

Operating Instructions

Model Nos. 943-A, B, C, D, BK
Tomato Saber™



Prince Castle's Tomato Saber™ slicer is designed to precisely slice whole tomatoes. With the exclusive Perma-Tight™ disposable blade cartridge system, this unit never requires blade tightening or adjusting. Engineered for durability and long life, the Tomato Saber™ features self-lubricating bearings, a safety shield, and a contoured Tomato Pusher Assembly. The unit is shipped with a Tomato Catcher, Table Stop Assembly, and a cleaning brush.

Hazard Communication Standard (HCS) — The Procedure(s) in this equipment manual include the use of chemical products. These chemical products will be highlighted with bold face letters followed by the abbreviation (HCS) in the text of the manual. See the Hazard Communication Standard (HCS) Manual for the appropriate Material Safety Data Sheet(s) (MSDS).

TABLE OF CONTENTS

Set-Up	2
Operation	2
Maintenance	3
Troubleshooting Guide	3
Ordering/Service Information	3
Exploded View	4
Parts List	5

LIMITED WARRANTY

This product is warranted to be free from defects in material and/or workmanship for a period of one (1) year from date of original installation, not to exceed 18 months from date of shipment from our factory **with the exception of the blade cartridge**. Blade cartridge is warranted to be free from defects at time of delivery only.

Any component which proves to be faulty in material and/or workmanship will be replaced or repaired (at the option of Prince Castle, Inc.) without cost (including freight and duty) to the customer for parts or labor.

This warranty is subject to the following exceptions/conditions:

- Use of products other than tomatoes will void this warranty.
- This equipment is portable; charges for on-location service (e.g., trip charges, mileage) are not included in the provisions of this warranty.
- Damage caused by carelessness, neglect and/or abuse (e.g., dropping, tampering or altering parts), equipment damaged in shipment, by fire, flood or an act of God is not covered under this warranty.

PRINCE CASTLE LLC 
WORLDWIDE

 A Marmon Group/Berkshire Hathaway Company

355 East Kehoe Blvd. • Carol Stream, IL 60188 USA

Telephone: 630-462-8800 • Fax: 630-462-1460

Toll Free: 1-800-PCASTLE

www.princecastle.com

SET-UP

1. After you have removed the Tomato Saber™ from the carton, inspect the unit for signs of damage. If there is damage to the unit:
 - Notify carrier within 24 hours after delivery.
 - Save carton and packing materials for inspection purposes.
 - Contact your Prince Castle dealer for replacement or the Prince Castle Customer Sales Department at 1-800-722-7853 if purchased directly.
2. Verify that all parts have been received.
 - Tomato Saber™ slicer with Perma-Tight blade cartridge.
 - Tomato Catcher — neatly catches sliced tomato.
 - Table Stop Assembly — stabilizes unit for easier slicing.
3. Place slicer on prep table or flat surface.

TIP: Use the ripest tomatoes first.

OPERATION

IMPORTANT: The Tomato Saber™ is designed to slice tomatoes only. Using it to slice other products may damage the slicer and will void the warranty.

1. Grasp handle and pull all the way back to end of stroke.
2. Insert tomato in front of the Tomato Pusher Assembly with the core side down. See **figure 1**.

figure 1

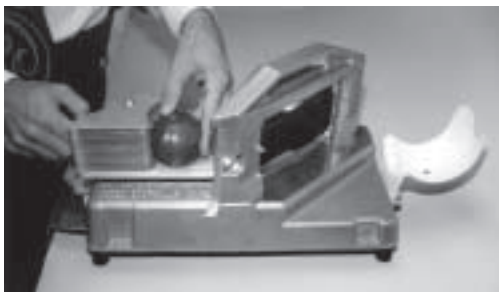

3. Push handle with a quick, firm stroke all the way through the blades and until the pusher stops. The tomato will be completely sliced. See **figure 2**.

figure 2

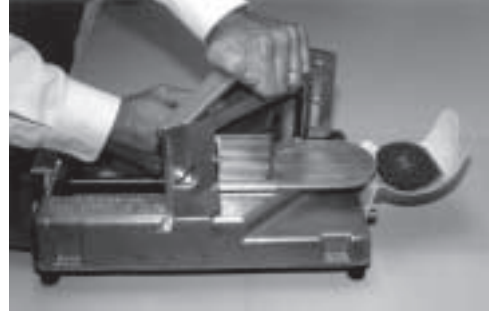

4. Remove tomato slices from Tomato Catcher.
5. Place tomato slices in a clean, sanitized 1/6 size tomato pan with false bottom.
6. Save end pieces and any slices with green core centers (stem) showing. These are used for Fajita products.
7. Place pan in prep table. (Additional pans should be covered and placed in walk-in cooler. Maximum 3 hour total holding time with no longer than 1 hour in walk-in, no more than 2 hours at prep table.)

Identify pans stored in walk-in with the 1 hour “remove from walk-in” time.

CLOSE

Daily cleaning of the tomato slicer will keep this piece of equipment clean and free from build-up. However, if residual tomato juice is allowed to remain on the tomato slicer for long periods, a hard white deposit will form on the cutting blades which becomes very hard to remove and will dull the blades.

MAINTENANCE

REPLACING BLADES

1. Grasp round, red handle and pull carrier assembly all the way back.
2. While holding the bridge with one hand, firmly grasp the blade cartridge by the finger grip (machined arrow pointing up) with other hand. Pull the blade cartridge all the way out. The blade cartridge retaining spring clip will release the cartridge. See **figure 3**.

figure 3



3. Slide the new blade cartridge with arrow facing up. See **figure 4**.

figure 4



4. Firmly push the blade cartridge into place until it snaps into the blade clip. See **figure 5**.

figure 5



5. Place the old blade cartridge in the packaging from new blade cartridge and properly discard.
6. Slide the Pusher Head halfway through the blades.
7. Looking at the blades from eye level, verify that each Blade is in the center of the Pusher Head Plates.
8. If one or more of the blades are not aligned properly (See **figure 6**), follow the instructions below.

figure 6

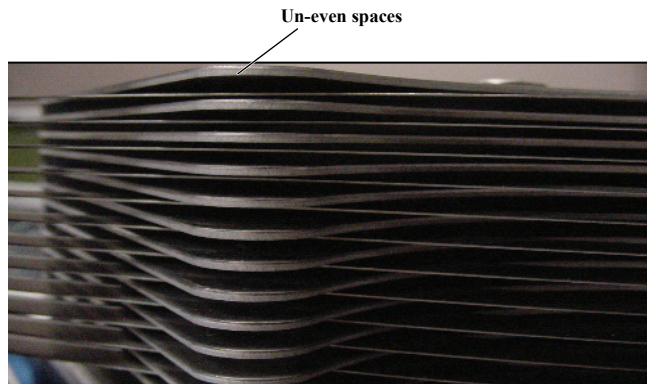

9. Using a flat-head screwdriver, bend the Pusher Head Plate either up or down, depending on the location of the blade (See **figure 7**).

figure 7

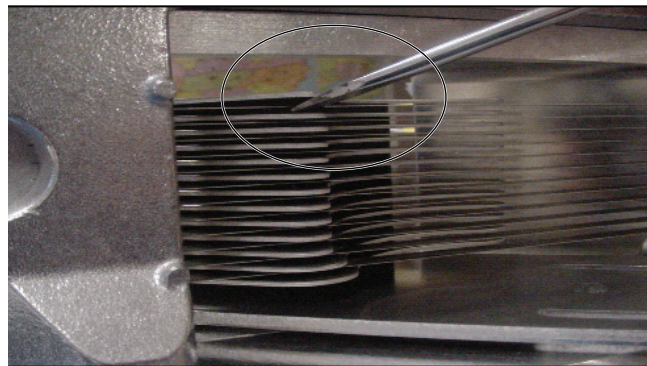

figure 8

10. Repeat step 9, for all Pusher Head adjustments.
NOTE: It is only necessary to bend the front of the Pusher Head Plate.
11. Once the blade clears the front of the Pusher Head Plate, the plate will glide through evenly the rest of the way.

TROUBLESHOOTING GUIDE

PROBLEM	CAUSE	SOLUTION
Pusher handle is hard to push.	Friction on guide rods.	Apply water to guide rods.
Tomato won't go all the way through the blades.	Blades are dull or damaged.	Replace blades. (See exploded view and parts list for correct part number.)

ORDERING/SERVICE INFORMATION

1. WHERE AND HOW TO ORDER REPLACEMENT PARTS

To order replacement parts, look on the back of your Prince Castle Price List for the name and phone number of your local Prince Castle Service Center. You may also call 1-800-298-1862 for the name of your local Service Center.

2. PARTS RETURNS

To return parts to your Service Center for credit, you must obtain authorization from your Service Center.

IMPORTANT: All warranty situations should be handled by your Authorized Prince Castle Service Center.

OUTSIDE THE U.S.

Contact your Kitchen Equipment Supplier or designated Service Center facility for parts and service.

EXPLODED VIEW

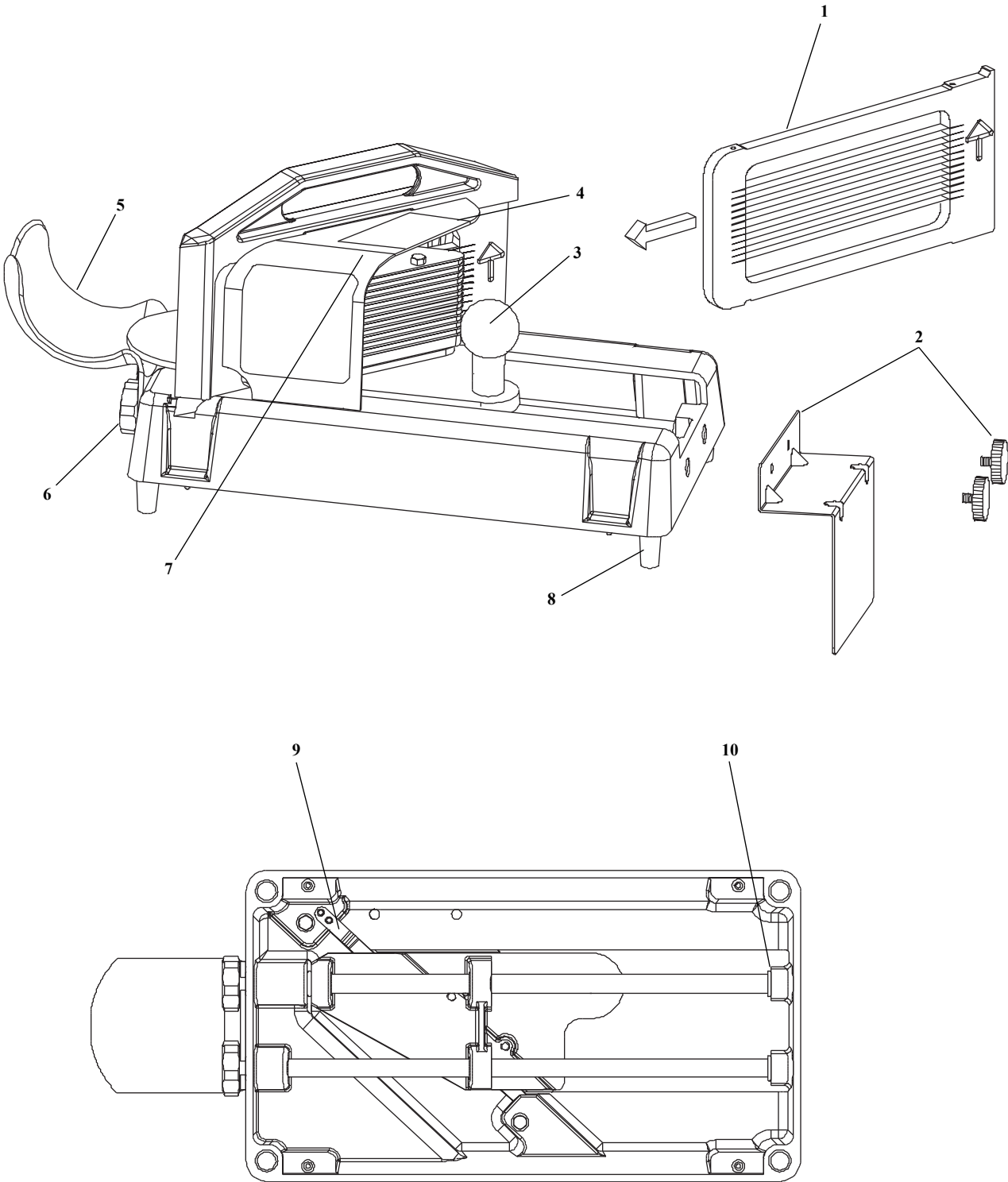

PARTS LIST

Item	Part Number	Description	Qty.	Function
1	943-038A	Blade Assembly, 3/16" (4.7 mm)	1	Provides cutting edge for slicing tomato.
	943-039A	Blade Assembly, 1/4" (6.35 mm)	1	Provides cutting edge for slicing tomato.
	943-039AH	Blade Assembly, 1/4" (6.35 mm)	1	Provides 11 blades for slicing tomato.
	943-040A	Blade Assembly, 3/8" (9.5 mm)	1	Provides cutting edge for slicing tomato.
	943-041A	Blade Assembly, 7/32" (5.5 mm)	1	Provides cutting edge for slicing tomato.
2	943-047S	Table Stop w/Knobs	1	Prevents slicer from moving.
3	943-077S	Pusher Handle w/Mounting Screw	1	Provides means for pushing tomato through blades.
4	943-050	Tomato Pusher Assembly, 3/16" (4.7 mm), 3/8" (9.5 mm)	1	Provides cutting edge for slicing tomato.
	943-051	Tomato Pusher Assembly, 1/4" (6.35 mm)	1	Provides cutting edge for slicing tomato.
	943-052	Tomato Pusher Assembly, 7/32" (5.5 mm)	1	Provides cutting edge for slicing tomato.
5	943-018S	Tomato Catcher	1	Captures tomato slices.
6	943-033S	Guide Rod Knobs (Pkg. of 2)	2	Keeps guide rods in place.
7	943-012S	Blade Guard	1	Prevents contact with sharp blades.
8	89-959S	Rubber Foot (Pkg. of 4)	4	Provides non-skid surface.
9	943-034S	Blade Latch Kit	1	Retains blade cartridge in place.
10	919-17S	Guide Rod Cushions (Pkg. of 2)	3	Cushions the forward motion of the carrier assembly to prevent wear.

PRINCE CASTLE LLC 
WORLDWIDE



A Marmon Group/Berkshire Hathaway Company

355 East Kehoe Blvd. • Carol Stream, IL 60188 USA

Telephone: 630-462-8800 • Fax : 630-462-1460

Toll Free: 1-800-PCASTLE

www.princecastle.com