



CAUTION: Read Instructions before installing and using appliance

Original Instructions Operation Manual



CTD & CTDE Vertical Contact Toasters



The CTD Series Vertical Contact Toaster

This appliance is designed for toasting bread products in a commercial kitchen. Customer-adjustable features include:

- Bun Compression Adjustment
- Set Point Temperature
- Time (Speed of Conveyor)

The Conveyor Belt options may be wire, metal (Stainless Steel) or silicone.

LIMITED WARRANTY

This product is warranted to be free from defects in material and/or workmanship for a period of one (1) year from date of original installation, not to exceed 18 months from date of shipment from our factory. Any part or component which proves to be faulty in material and/or workmanship within the warranty period will be replaced or repaired (at the option of Prince Castle LLC) without cost to the customer for parts or labor.

This warranty is subject to the following exceptions/conditions:

- Use of any non-genuine Prince Castle parts voids this warranty and all work must be performed by an authorized Prince Castle Service Agent.
- All labor shall be performed during regular work hours. Overtime premium will not be covered.
- Travel charges are limited to 100 miles (200 kilometers) round trip, 2 hours travel time, one trip per repair.
- Damage caused by carelessness, neglect, and/or abuse (e.g., using wrong current, dropping, tampering with or altering electrical components, or improper cleaning) is not covered.
- Equipment damaged in shipment, by fire, flood or an act of God is not covered.
- Damage to non-stick coated surfaces is not covered by this warranty.

TABLE OF CONTENTS

Equipment Registration	2
Safety Information	3
Safety Features	3
Electrical Specifications	3
Installation	3
Operation	5
Setting Adjustments	6
Manager Advanced Programming	8
Cool Down.....	10
Daily Planned Maintenance	10
Troubleshooting	12
Installing the Silicone Belt	13
Removing the Silicone Belt	14
Accessories	15
Service Kits	16
Monthly Planned Maintenance.....	19
Exploded Views.....	21
Wiring Diagram	25



355 East Kehoe Blvd. • Carol Stream, IL 60188 USA
Telephone: 630-462-8800 • Toll Free: 1-800-PCASTLE
Fax: 630-462-1460 • www.princecastle.com



Equipment Registration



Thank you for purchasing your equipment from the Marmon Foodservice Technologies family of brands. From technical support to warranty dispatch to replacement parts sales, Marmon Link provides your entire after-sales support for Cornelius, Prince Castle, Silver King, and Angelo Po America Equipment.

Registering your equipment will help us keep you up to date on equipment information, preventative maintenance resources, and other topics. Your equipment's warranty will not be affected if you choose not to fill out this form.

To expedite the process, we ask that you have the following:

- The serial numbers of the equipment you purchased.
- The name and email address of a designated store contact.
- The general store information, including address location number.

Register Your Equipment

To Maximize Your Benefits

- Comprehensive after-sales service
- Over the phone technicians
- Quick-ship parts

Complete with:

- Serial Number
- Equipment location details



Scan the QR Code

Your equipment serial number will be validated against our database of existing serial numbers. If you are having difficulties entering a valid number, please contact Marmon Link at **1-866-275-6392**.

Safety Information

WARNING

Indicates information important to the proper operation of the unit. Failure to observe may result in damage to the equipment and/or severe bodily injury or death.

CAUTION

Indicates information important to the operation of the unit. Failure to observe may result in damage to the equipment.

IMPORTANT: Prince Castle reserves the right to change specifications and product design without notice. Such revisions do not entitle the buyer to corresponding changes, improvements, additions or replacements for previously purchased equipment.

Safety Features

The CTD & CTDE Vertical Contact Toasters include the following safety features:

- If a unit becomes too hot, it shuts down.
- If one of the conveyor doors is open during operation, both conveyors turn off and an alert screen appears.

Electrical Specifications

Model Number	Description	Volts	Hz	Watts	Amps
CTD-W	Toaster [Wire Belt]	208-240	50/60	1700-2250	7.08 / 10.82
CTD-M	Toaster [Metal Belt]	208-240	50/60	1700-2250	7.08 / 10.82
CTD-S	Toaster [Silicone Belt]	208-240	50/60	1700-2250	7.08 / 10.82
CTD-W-CE	Toaster [Wire Belt]	220-240	50/60	1650-2000	6.87 / 9.10
CTD-M-CE	Toaster [Metal Belt]	220-240	50/60	1650-2000	6.87 / 9.10
CTD-S-CE	Toaster [Silicone Belt]	220-240	50/60	1650-2000	6.87 / 9.10
CTDE-W	Toaster [Wire Belt]	208-240	50/60	2440-3250	9.40 / 14.40
CTDE-M	Toaster [Metal Belt]	208-240	50/60	2440-3250	9.40 / 14.40
CTDE-S	Toaster [Silicone Belt]	208-240	50/60	2440-3250	9.40 / 14.40
CTDE-W-CE	Toaster [Wire Belt]	220-240	50/60	3000	12.5 / 13.64
CTDE-M-CE	Toaster [Metal Belt]	220-240	50/60	3000	12.5 / 13.64
CTDE-S-CE	Toaster [Silicone Belt]	220-240	50/60	3000	12.5 / 13.64
XXX-XX-AX	Auxiliary Heater*	208-240	50/60	200-250	0.83 / 1.21

* To add an Auxiliary Heater, insert (AX) after belt type [i.e., CTD-WAX].

Installation

WARNING

The appliance is not intended for use by persons (including children) with reduced physical, sensory or mental capabilities, or lack of experience and knowledge, unless they have been given supervision or instruction concerning use of the appliance by a person responsible for their safety. Children shall not be allowed to use or play with this appliance.

1 Unpack and inspect.

Remove the unit from the carton and inspect for signs of damage. If there is damage to the unit:

- Notify the carrier within 24 hours of delivery.
- Save carton and packaging materials for inspection purposes.
- Contact your local dealer, or if purchased directly, the Prince Castle Sales Department at 1-800-722-7853 or 630-462-8800 to arrange for a replacement unit.

2 Verify parts.

Confirm that all parts have been received:

- CTD or CTDE Contact Toaster
- Release Sheet Kit
- Bun Infeed
- Instruction Packet

3 Place toaster on flat surface.

CAUTION

Two-person lift, unit weight:

- CTD, >56 lbs. (25 kg)
- CTDE, >75 lbs. (34 kg)

Installation (continued)

CAUTION
 Equipment must always be elevated from the floor during cleaning and operation.

4 Remove bun infeed by lifting from toaster.
 Remove blue and/or white protective covering from the outside of the unit.

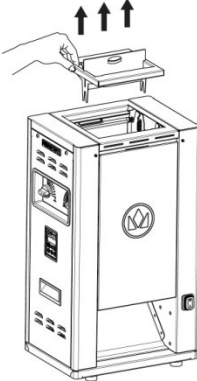

5 Open the conveyor doors.
 For each door, lift slightly from the bottom to unlatch and guide down to the surface. The door is hinged at the bottom and will stay connected to the unit.

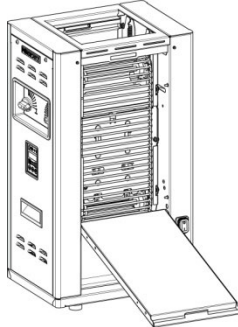

6 Clean the bun infeed, conveyors and inside of the doors.
 Put on neoprene gloves. Dampen a clean cloth with lukewarm soap and water. Wipe the conveyor, rotating it as you clean to reach its entire surface. Wipe the infeed and inside of the doors. Wipe down each part again with a fresh, clean, sanitized cloth.

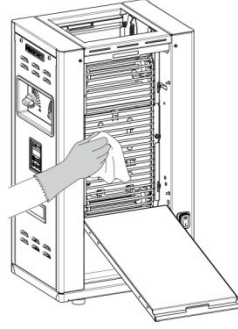

7 Close the conveyor doors.
 Once the unit has been wiped down and cleaned lift the doors and press, they will lock in their upright position.

8 Clean the outside of the toaster.
 Using a clean cloth with lukewarm soap and water, wipe the outside of the entire toaster. Wipe again with a dry, clean, and sanitized cloth.

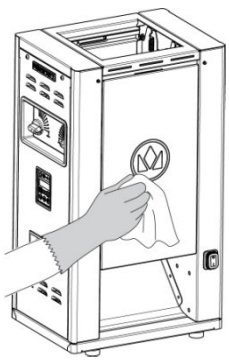

9 Install release sheet.
 Hang the folded PTFE release sheet, straddling the platen. The tan material will need to fully cover both sides of the heating element. This is important in preventing the bun from sticking.

CAUTION
 Moisture coming out of the product can cause it to stick against the heated aluminum surfaces if the PTFE sheet is not properly used.

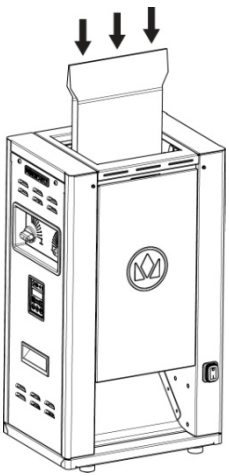

10 Reinstall the bun infeed.

11 Plug unit in.
 Plug unit into a grounded receptacle with a matching plug configuration.

WARNING
 All electrical connections must be in accordance with local electrical codes and any other applicable codes.
 This appliance can be used by children aged from 8 years and above and persons with reduced physical, sensory or mental capabilities or lack of experience and knowledge if they have been given supervision or instruction concerning use of the appliance in a safe way and understand the hazards involved. Children shall not play with the appliance.

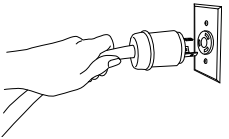

Operation

1 Turn unit on.

Turn the power switch to 'ON' position. The switch is located on the bottom right of the unit. The switch will light up green if the unit is successfully powered on.



The Prince Castle logo will be displayed, followed by a screen that contains the model's current software and hardware numbers.

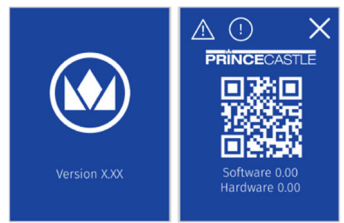

3

WARNING

BURN/ELECTRICAL SHOCK HAZARD! Platen area is HOT and can cause severe burns or severe shock. Keep hands and objects out of the toaster unit! Failure to exercise caution may result in serious injury! Follow the Cool Down procedure before touching or working on internal apparatus.

When the current platen temperature reaches the set point temperature, the Run/Home screen appears.

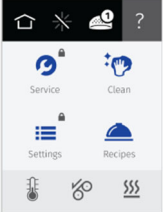

4 Make any desired adjustments.

Use the instructions in *Setting Adjustments* to make changes to:

- Crush Adjustment
- Recipes
- Temperature
- Toast Time/Speed
- Auxiliary heat % (For AX units only)

2 Wait through warm-up.

On the Warm-Up screen, you can view the current recipe in the top right, followed by the set point temperature and the current platen temperature as the unit warms. The thermometer icon will be flashing to indicate that the unit is still reaching its desired temperature.

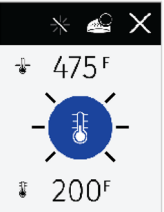

You can pause warm-up by pressing the thermometer icon if you want to change the set point. The Run/Home screen will appear. To change the set point:

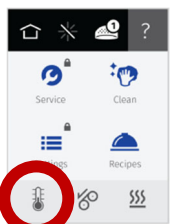

- A. Press the thermometer icon on the bottom of the Run/Home screen. The Edit Run Parameters screen will appear.
- B. Press the Plus (+) symbol to increase the set point or the Minus (-) symbol to decrease the set point.
- C. Press the check mark to accept the setting. The Warm-Up screen reappears, and warm-up continues.

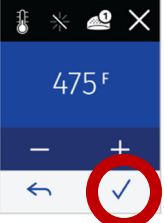

NOTE: If you don't want to accept the change, you can wait for the screen to time out or you can press the back arrow.

5 Begin continuous feeding.

Feed product into top of toaster, sending the crowns down the back lane and the heels down the front lane. The bun should be placed with cut sides toward the middle of the unit. Images on the infeed will show correct orientation.

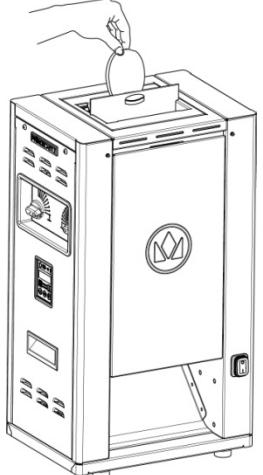

Toasted product will exit at the base of the toaster.

FACTORY PIN NUMBER IS 2222

Setting Adjustments

1 Change Bun Compression adjustment.

Because the platen has separate segments for the “Crown” (left) side and “Heel” (right) side, they are adjusted separately, each with its own compression control. For example, if the heels are slipping through without making good contact with the platen and look like they need more toasting, the right compression adjustment switch may need to be moved to a different letter. Or, if the crowns seem unusually thick and are being compressed too much or over-toasted, the left compression adjustment switch may need to be moved to a different number.

- Turn the left-side compression adjustment closer to “1” to allow for thicker crowns or closer to “10” for thinner crowns.
- Turn the right-side compression adjustment closer to “A” to allow for thicker heels or closer to “I” for thinner heels.

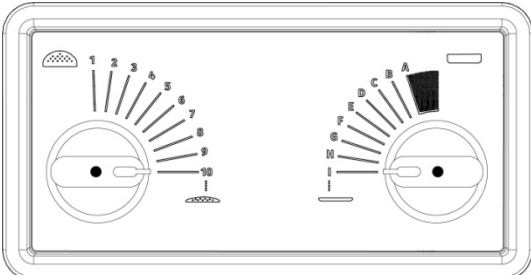

2 Change the Recipe that is running.

The unit has four recipes to choose from. From the Run/Home screen, you can change the Recipe that is currently running.

- Press the Recipes icon on the Run/Home screen. The Recipes screen will appear.
- Press the Left arrow or Right arrow to change the recipe.
- Press the check mark to accept the change.

NOTE: If you don't want to accept the change, you can press the Return arrow.

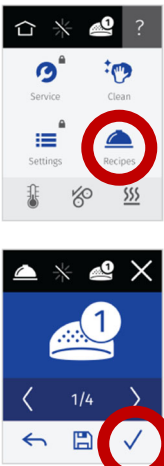

3 Change the Temperature set point.

From the Run/Home screen, you can change the Temperature set point.

- Press the thermometer icon on the bottom of the Run/Home screen. The Edit Run Parameters screen will appear with the current set point.
- Press the Plus (+) symbol to increase the set point or the Minus (-) symbol to decrease the set point.
- Press the check mark to accept the setting.

NOTE: If you don't want to accept the change, you can press the Return arrow.

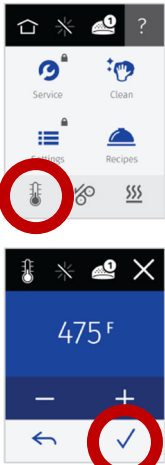

4 Change the Time/Speed set point.

From the Run/Home screen, you can change the Time/Speed set point.

Range: 6-40 seconds
 Default: 17 seconds

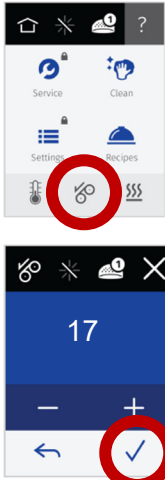

- Press the center icon on the bottom of the Run/Home screen. The Edit Run Parameters screen will appear with the correct set point.
- Press the Plus (+) symbol to increase the set point or the Minus (-) symbol to decrease the set point.
- Press the check mark to accept the setting.

NOTE: If you don't want to accept the change, you can press the Return arrow.

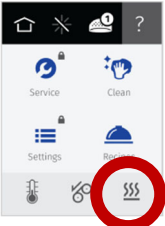

Setting Adjustments (continued)

5 Optional AUX Heater Models: Increase/Decrease the percentage of auxiliary heat.
From the Run/Home screen, you can change the percentage of auxiliary heat if your toaster has this option.

- Press the heat icon on the bottom of the Run/Home screen. The Edit Run Parameters screen will appear. The percentage of auxiliary heat is represented by a number from 0 to 10, where 0 is off and 10 is 100%.
- Press the Plus (+) symbol to increase the setting or the Minus (-) symbol to decrease the setting.
- Press the check mark to accept the setting.

NOTE: If you don't want to accept the change, you can press the Return arrow.

6 Save the current settings as the current recipe.
If you have adjusted the current settings and you want to save the settings to the current recipe, you can do this on the Recipe screen.

- Press the Recipes icon on the Run/Home screen. The Recipes screen will appear.
- Press the Save icon on the center bottom of the screen. (This icon will only appear if you have changed a setting.)

NOTE: If you don't want to change the recipe, you can press the Return arrow.



Manager Advanced Programming

1 Adjust screen brightness setting.
From the Run/Home screen, you can change the screen brightness if you have a PIN.
FACTORY PIN: 2222

A. Press the Settings icon on Run/Home screen. The Access Settings/Service screen will appear.

B. Type your 4-digit PIN and press the check mark. The Settings screen will appear.

C. Press the Screen Brightness icon. The Screen Brightness screen will appear. The screen brightness is represented by a setting from 1 to 10, where 10 is the brightest and 1 is the dimmest.

D. Press the Plus (+) symbol to increase the setting or the Minus (-) symbol to decrease the setting.

E. Press the check mark to accept the setting.

NOTE: If you don't want to accept the change, you can press the Return arrow.

2 Access statistics. From the Run/Home screen, you can access statistics if you have a PIN.

A. Press the Service icon on Run/Home screen. The Access Settings/Service screen will appear.

B. Type your 4-digit PIN and press the check mark. The Service screen will appear.

C. Press the Statistics icon. The Statistics screen will appear. The statistics screen shows relevant statistics with a timestamp.

D. Press the Return arrow to return to the Run/Home screen.

FACTORY PIN NUMBER IS 2222

Manager Advanced Programming (continued)

3 **Change the temperature units (°F/°C).** From the Run/Home screen, you can change the temperature units if you have a Service PIN code.

NOTE: You will need to obtain the Service PIN code from your service representative to access this feature.

A. Press the Settings icon on Run/Home screen. The Access Settings/Service screen will appear.

B. Type the Service PIN code and press the check mark. The Settings screen will appear.

C. Press the Temperature Units icon. The Temperature Units screen will appear with the current setting selected.

D. Press the other setting.

E. Press the check mark to accept the setting.

NOTE: If you don't want to accept the change, you can press the Return arrow.

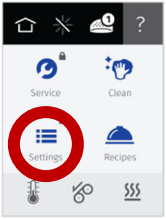
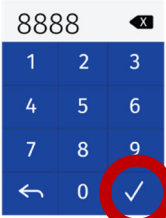
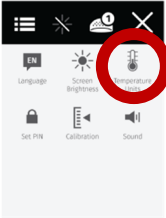
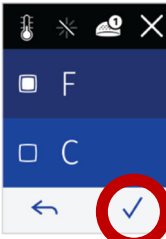
Cool Down

⚠️ WARNING
BURN/ELECTRICAL SHOCK HAZARD! Platen area is HOT and can cause severe burns or severe shock. Keep hands and objects out of the toaster unit! Failure to exercise caution may result in serious injury! Follow this procedure before touching or working on internal apparatus.

1 Press the Clean icon on the Run/Home screen.

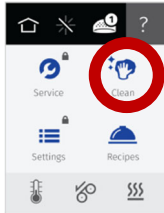

The Clean screen will appear. On the Clean screen, you can view the current platen temperature, the thermometer icon, and the cool-down temperature set point.

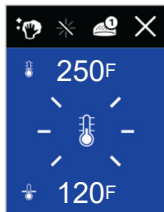

2 Wait while the toaster cools down.

The thermometer icon will be flashing until the current platen temperature reaches the cleaning set point temperature. The Cleaning icon will then appear, indicating it is okay to clean or work on the toaster.



Daily Planned Maintenance

⚠️ WARNING
BURN/ELECTRICAL SHOCK HAZARD! Platen area is HOT and can cause severe burns or severe shock. Keep hands and objects out of the toaster unit! Failure to exercise caution may result in serious injury! Turn the unit off, unplug it and follow the Cool Down procedure before touching or working on internal apparatus.

⚠️ WARNING
If the supply cord is damaged, it must be replaced by the manufacturer, its service agent, or similarly qualified person to avoid a hazard.

⚠️ CAUTION
Do not immerse toaster in water. Do not clean with a water hose or jet spray. Do not use abrasive cleaners, pads or tools on the platen or the release sheet. Failure to exercise caution will result in damage to the unit and will not be covered by warranty. Cleaning and user maintenance shall not be made by children without supervision.

1 Gather cleaning materials. You will need clean cloths, neoprene gloves, foodservice safe multipurpose detergent solution, sanitizer solution, and lukewarm soap and water.

2 Follow the Cool Down procedure before cleaning.

3 Turn the toaster off and unplug. Turn the On/Off switch located on the bottom right of the unit to the 'OFF' position. The green LED switch will also turn off.

The plug removed from the outlet shall remain clearly visible to the operator during the maintenance procedure. Do not pull on the cord, grab the plug receptacle instead.

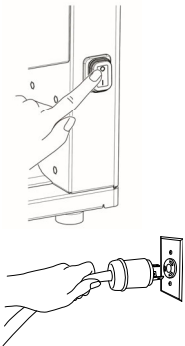

4 Remove bun infeed and release sheet. Lay the release sheet on a flat surface.

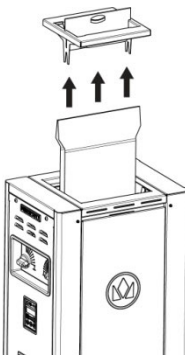

Daily Planned Maintenance (continued)

- 5** **Open the conveyor doors.** For each door, lift slightly from the bottom to unlatch and guide down to the surface.

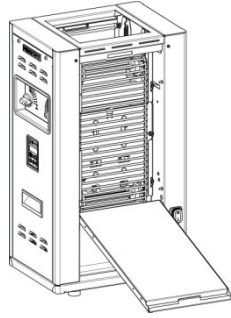

- 6** **Clean the release sheet.** Put on neoprene gloves. Dampen a clean cloth with lukewarm soap and water. Wipe down both sides of the release sheet, making sure all built-up sugar is removed. Wipe down both sides with a clean cloth, dampened with water, to rinse. Allow to air dry.

NOTE: Rotate sheets daily for longer life. Depending on volume of product toasted, sheets should be replaced every 4 to 6 weeks.

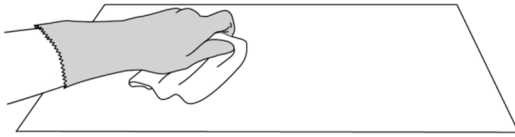

- 7** **Reinstall the release sheet.**

- 8** **Clean the conveyors, inside of the doors, and bun infeed.** Wipe the conveyor with a clean cloth dampened with multipurpose detergent solution, rotating it as you clean to reach its entire surface. Wipe the entire surface with a clean cloth, dampened with sanitizer solution. Dampen a clean cloth with lukewarm soap and water. Wipe the inside of doors and bun infeed. Wipe the inside of the doors and bun infeed again with a fresh, clean, sanitized cloth.



Do not use abrasive cleaners or pads on the conveyor surface.

- 9** **Close the conveyor doors.**

- 10** **Reinstall the bun infeed.**

- 11** **Clean outside of the toaster.** Dampen a clean cloth with lukewarm soap and water. Wipe down the outside of the entire toaster. Wipe down the entire toaster again with a fresh, clean, sanitized cloth.

Note: More frequent cleaning is necessary if buttering before toasting.

DO NOT clean the power cord with acidic solutions.



- 12** **Power Cord Maintenance**

Inspect power cord regularly for signs of wear or contamination. If dirty, dampen a clean cloth with lukewarm soap and water. Wipe down the power cord. Wipe down again with a fresh, clean, sanitized cloth.

Note: More frequent cleaning is necessary if buttering before toasting.

DO NOT clean the power cord with acidic solutions. Use only manufacturer-recommended cleaning methods.

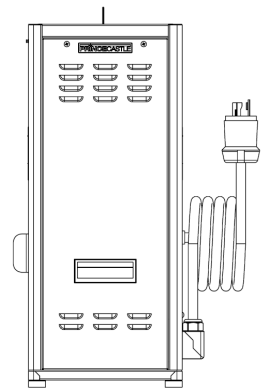

Maintaining Silicone Wraps

- The silicone wrap can be left on the unit for this operation.
- Open the door to gain access to the wrap.
- Using a clean and damp rag, wipe the visible surface of the wrap. After wiping, rotate the conveyor forward and continue wiping, ensuring the belt does a full 360 around the unit.
- A clean and maintained belt should last approximately 6 months but varies by customer and volume put through the toaster.

Troubleshooting



To avoid possible personal injury and/or damage to the unit, inspection, test and repair of electrical equipment should be performed by qualified service personnel. The unit should be unplugged when servicing, except when electrical tests are required. Use extreme care during electrical circuit tests. Live circuits will be exposed.



BURN/ELECTRICAL SHOCK HAZARD! Platen is HOT and can cause severe burns or severe shock. Keep hands and objects out of the toaster unit! Failure to exercise caution may result in serious injury! Turn the unit off, unplug it and let it cool down completely before touching or working on internal apparatus. The plug removed from the outlet shall remain clearly visible to the operator during the maintenance procedure.

PROBLEM	POSSIBLE CAUSE	SOLUTION
Unit has no power	Unit unplugged	Plug unit in.
	Breaker tripped	Reset breaker.
	Loose connection on power switch	Call Tech Support 1-800-722-7853
	Inoperable power switch	
Unit will not heat up	Loose connection on platen	Call Tech Support 1-800-722-7853
	Open platen	
	Loose connection to the main control board	
	Inoperable main control board	
	Inoperable TRIAC	
Unit heats up, but the conveyors do not run	The conveyor door is ajar	Verify that the door is closed.
	Inoperable motor	Call Tech Support 1-800-722-7853
	Stripped drive gear	
	Stripped conveyor gear	
	Jammed conveyor assembly	
Not toasting properly (under- or over-done)	Inoperable RTD-probe	Call Tech Support 1-800-722-7853
	Improper set point	Adjust set point in programming (see <i>Setting Adjustments</i> section).
	Improper compression	Adjust compression (see <i>Setting Adjustments</i> section).
	Torn or soiled release sheet	Clean or replace release sheet.
	Bad platen	Call Tech Support 1-800-722-7853
Jumpy or blank display	Improper ground	Call Tech Support 1-800-722-7853
	Inoperable display	
	Inoperable main control board	
	Loose wiring harness	
E01 error code visible on display	Relay shorted or open	Call Tech Support 1-800-722-7853
E02 error code visible on display	Conveyor 1 either jammed or not working	Call Tech Support 1-800-722-7853
E03 error code visible on display	Conveyor 2 either jammed or not working	Call Tech Support 1-800-722-7853
E05 error code visible on display	Set point temperature not reached in expected time	Call Tech Support 1-800-722-7853
E06 error code visible on display	Software files on USB not valid	Call Tech Support 1-800-722-7853
E07 error code visible on display	Transferred software files on external Flash not valid	Call Tech Support 1-800-722-7853
E08 error code visible on display	Temperature sensor open or shorted	Call Tech Support 1-800-722-7853
E09 error code visible on display	Current platen temperature 20°F higher than set point temperature	Call Tech Support 1-800-722-7853
E10 error code visible on display	Current platen temperature 20°F lower than set point temperature	Call Tech Support 1-800-722-7853
N1 notification visible on display	Reminder to clean	Clean unit and delete message.

Installing the Silicone Belt

1 Insert the silicone belt into the unit.



4 Confirm that the rod is fully inserted into the zipper.



2 Confirm that the guide bead on the silicone belt matches with the conveyor rollers.



5 Push the conveyor down and forward. The springs will engage and pull the silicone belt into place.



3 Align the zipper and insert the connecting pin. It is critical that the zipper is in the correct position.



6 Wipe down the belt to remove any debris from installation. Close the door and return to normal operation.



Removing the Silicone Belt

1 Open the door by placing a hand below the door and lifting.



3b Fully remove the connecting pin.



2 Press downward on the top of the conveyor and pull towards the door. The tension on the belt will be removed.



4 Remove the silicone wrap from the conveyor.



3a Locate the belt seam and remove the connecting pin.



Accessories

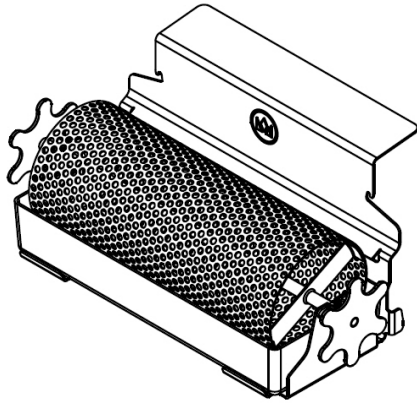

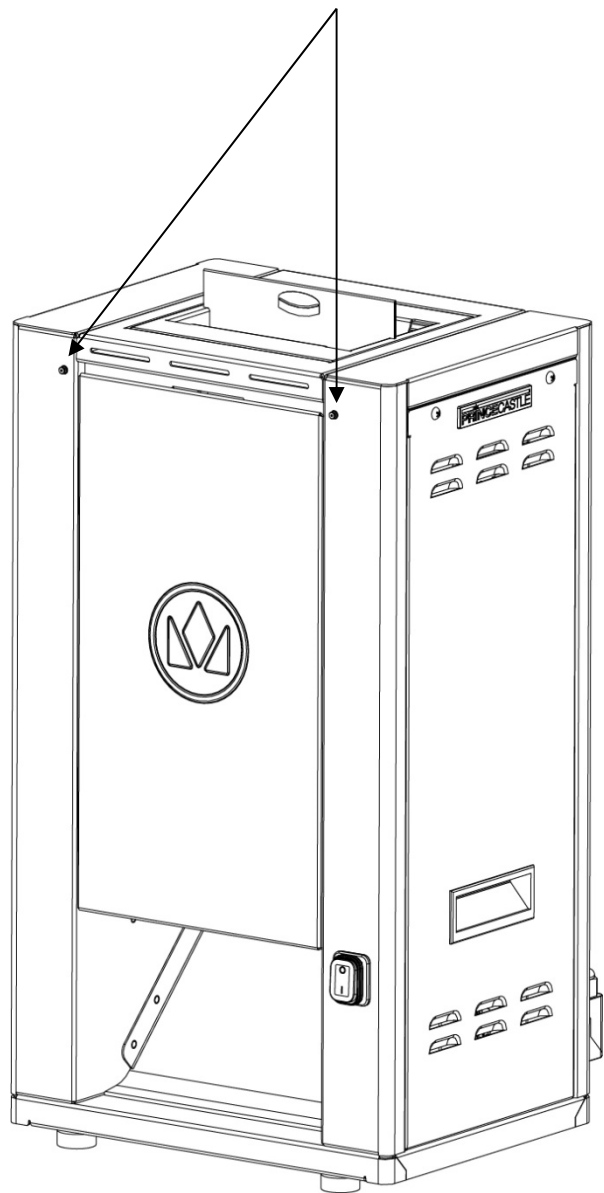

511-142 Butter Wheel, CTD
511-141 Butter Wheel, CTDE

Butter Wheel
Hanging Points

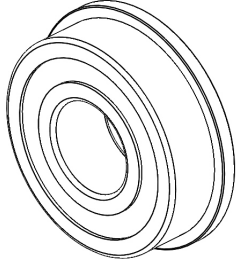
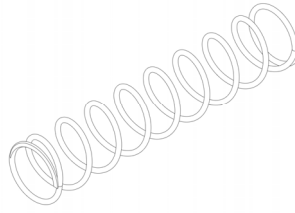
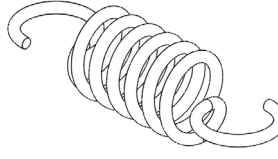
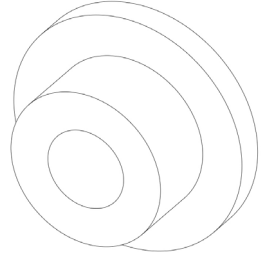
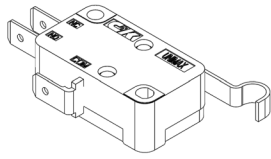
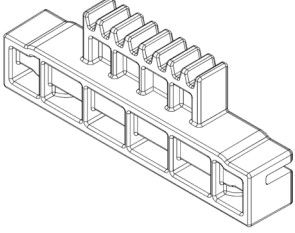
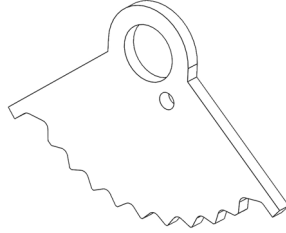
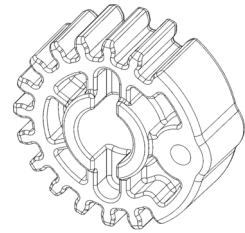
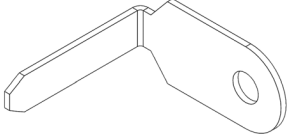
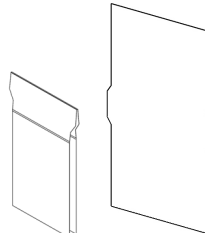
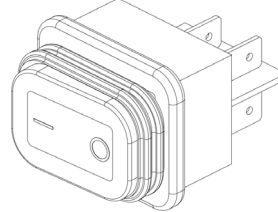
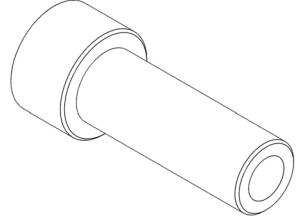
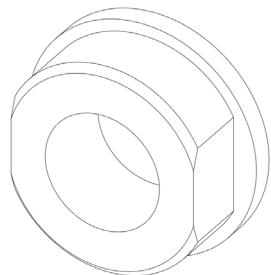
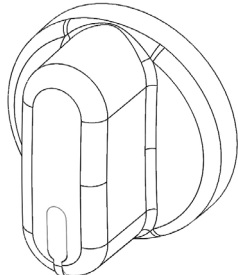

Service Kits

NOTE: See Exploded Views on page 20 for item location.

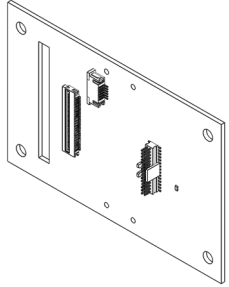
<p>1</p>  <p>299-070S Flanged Ball Bearing</p>	<p>2</p>  <p>301-084S Door Switch Spring</p>	<p>3</p>  <p>299-028S Conveyor Tensioner Spring</p>	<p>4</p>  <p>301-041S Chain Tensioner Bushing</p>
<p>5</p>  <p>525-127S Door Cut-Off Switch</p>	<p>6</p>  <p>301-023S Rack</p>	<p>7</p>  <p>301-044S Indexer</p>	<p>8</p>  <p>301-022S Gear</p>
<p>9</p>  <p>301-087S High Limit Probe Clip</p>	<p>10</p>  <p>301-156S (CTD) 302-169S (CTDE) Release Sheet. 5mil</p>	<p>11</p>  <p>78-233S Switch, Rocker, DPST, IP65, 16A</p>	<p>12</p>  <p>301-049S Detent Mechanism Bushing</p>
<p>13</p>  <p>301-025S Compression Adjust. Sleeve Bearing</p>	<p>14</p>  <p>70-081S Indicating Knob</p>	<p>15</p>  <p>301-074S Display Module</p>	<p>16</p>  <p>7500-006S LCD Adapter</p>

Service Kits (continued)

NOTE: See Exploded Views on page 20 for item location.

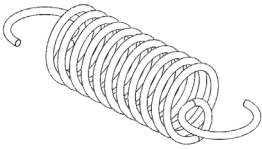
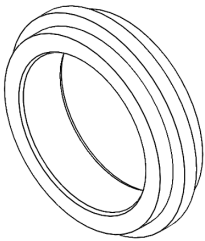
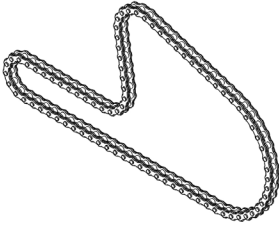
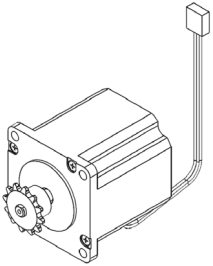
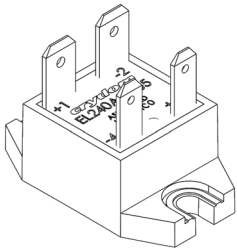
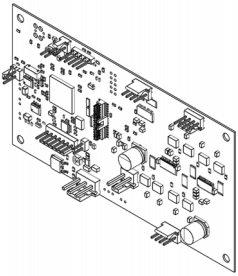
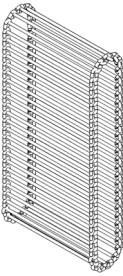
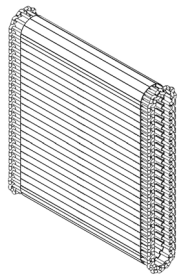
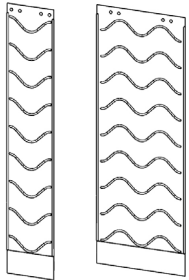
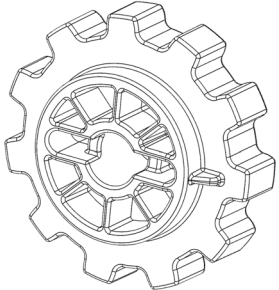
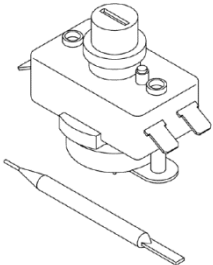
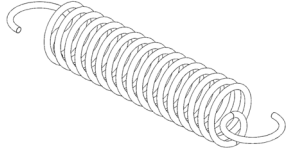
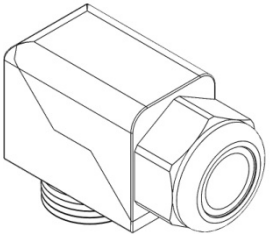
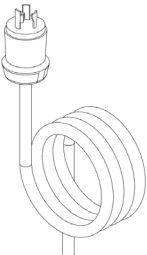
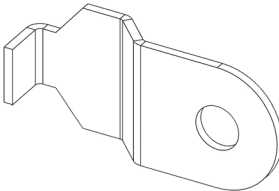
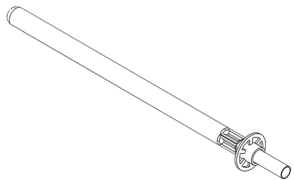
<p>17</p>  <p>301-035S Chain Tensioner Spring</p>	<p>18</p>  <p>301-115S Chain Tensioner Roller</p>	<p>19</p>  <p>301-030S Single Roller Chain 301-031S Double Roller Chain</p>	<p>20</p>  <p>301-038S Sprocket/Motor</p>
<p>21</p>  <p>302-034S (EL240A30-05)</p>	<p>22</p>  <p>7500-007S Control Board</p>	<p>23</p>  <p>301-014S (CTD) 302-015S (CTDE) Wire Conveyor Belt + Install Tool</p>	<p>24</p>  <p>301-013S (CTD) 302-016S (CTDE) Tracking Conveyor Belt + Install Tool</p>
<p>25</p>  <p>301-137S (CTD) 302-050S (CTDE) Silicone Belt</p>	<p>26</p>  <p>301-110S Conveyor Sprocket</p>	<p>27</p>  <p>301-117S Electric Thermostat</p>	<p>28</p>  <p>301-157S Detent Mechanism Spring</p>
<p>29</p>  <p>66-072S Cord Strain Relief Elbow</p>	<p>30</p>  <p>72-519S U.S. L6-20P 72-525S CEE7/7 Schuko</p>	<p>31</p>  <p>301-086S Temperature Probe Clip</p>	<p>32</p>  <p>527-468S Temperature Probe</p>

Service Kits (continued)

NOTE: See Exploded Views on page 20 for item location.

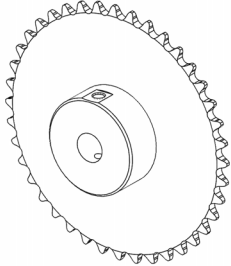
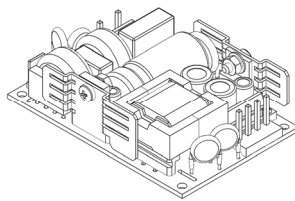
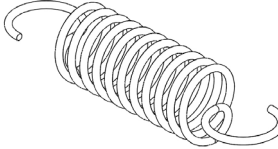
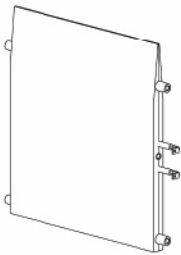
<p>33</p>  <p>301-039S Sprocket, 1/4" Pitch x 40TH</p>	<p>34</p>  <p>85-144-25S Power Supply, ECS45US24</p>	<p>35</p>  <p>301-034S Spring, Chain Tensioner-L</p>	<p>36</p>  <p>301-011S (CTD) 302-012S (CTDE) Heater Platen</p>
--	--	---	---

Not Shown:

<p>40</p> <p>88-828S Filter, EMI</p>	<p>41</p> <p>301-090S High Limit Cable CTD 302-041S High Limit Cable CTDE</p>	<p>42</p> <p>301-091S Harness, RTD</p>	<p>43</p> <p>301-092S Harness, LCD</p>
<p>44</p> <p>301-093S Harness, SSR</p>	<p>45</p> <p>301-094S Power Harness, AC</p>	<p>46</p> <p>301-095S Power Harness, DC</p>	<p>47</p> <p>301-097S Wire, Neutral</p>
<p>48</p> <p>301-098S Harness, Door Switch</p>	<p>49</p> <p>301-099S Harness, Auxiliary Heater</p>	<p>50</p> <p>302-036S Harness, Auxiliary Heater</p>	



HAEC-S (HEAT-ACTIVATED EQUIPMENT CLEANER)

Monthly Planned Maintenance

⚠️ WARNING
BURN/ELECTRICAL SHOCK HAZARD! Platen area is **HOT** and can cause severe burns or severe shock. Keep hands and objects out of the toaster unit! Failure to exercise caution may result in serious injury!

⚠️ CAUTION
 Do not immerse toaster in water. Do not clean with a water hose or jet spray. Do not use abrasive cleaners, pads or tools on the platen or the release sheet. Failure to exercise caution will result in damage to the unit and will not be covered by warranty. Cleaning and user maintenance shall not be made by children without supervision.

Applying HAEC-S

1 Gather cleaning materials. You will need clean cloths, neoprene gloves, and Heat Activated Grill and Toaster Cleaner (HAEC-S).

2 Power unit ON and let unit reach operating temperature (let unit run an additional 5 minutes after unit has reached operating temperature).

3 Open the side door.
 Lift the door slightly from the bottom to unlatch and guide down to the surface. The door is hinged at the bottom and will stay connected to the unit.



4 Pour a small amount of HAEC-S to a clean rag and apply it to the silicone belt.



5 Close the side door and let the unit run for 5 to 6 seconds.

6 Open side door.

7 Pour a small amount of HAEC-S to a clean rag and apply it to the silicone belt.

8 Close the side door and let the unit run for 5 to 6 seconds.

9 Repeat above steps until HAEC-S had been applied to entire silicone belt.

10 Close the side door and let toaster run for 8 to 10 minutes.

Monthly Planned Maintenance (continued)

Removing HAEC-S

1 Gather cleaning materials. You will need clean cloths, neoprene gloves, and warm water.

2 Open the side door. Dip the rag into the warm water and squeeze out the excess water from the rag. Wipe off the applied HAEC-S.



3 Close the side door and let unit run for 5 to 6 seconds.

4 Open the side door. Dip the rag into the warm water and squeeze out the excess water from the rag. Wipe off the applied HAEC-S.



5 Repeat the above steps until all of the HAEC-S has been removed.

Sanitizing Silicone Belt

1 Gather cleaning materials. You will need clean cloths, neoprene gloves, and sanitizer solution.

2 Open the side door and wipe the belt using a sanitized rag.



3 Close the side door and let unit run for 5 to 6 seconds.

4 Open the side door and wipe belt using a sanitized rag.

5 Close the side door and let unit run for 5 to 6 seconds.

6 Repeat the above steps until the entire belt has been sanitized.

Repeat the above steps for the second silicone belt.

Exploded Views

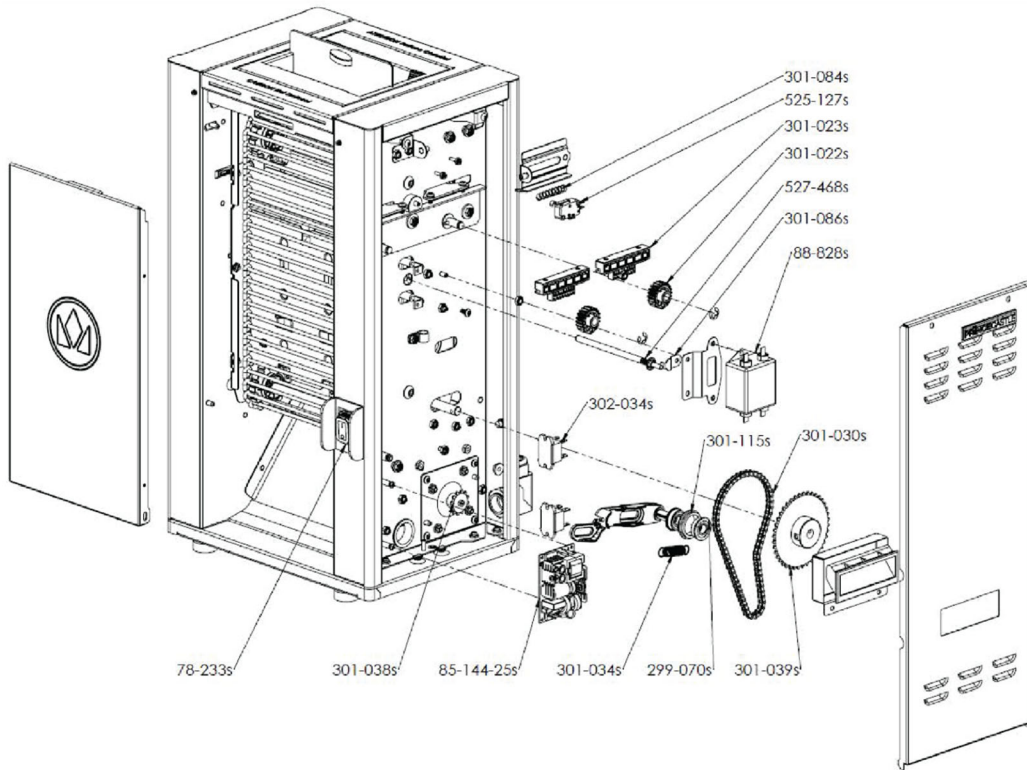
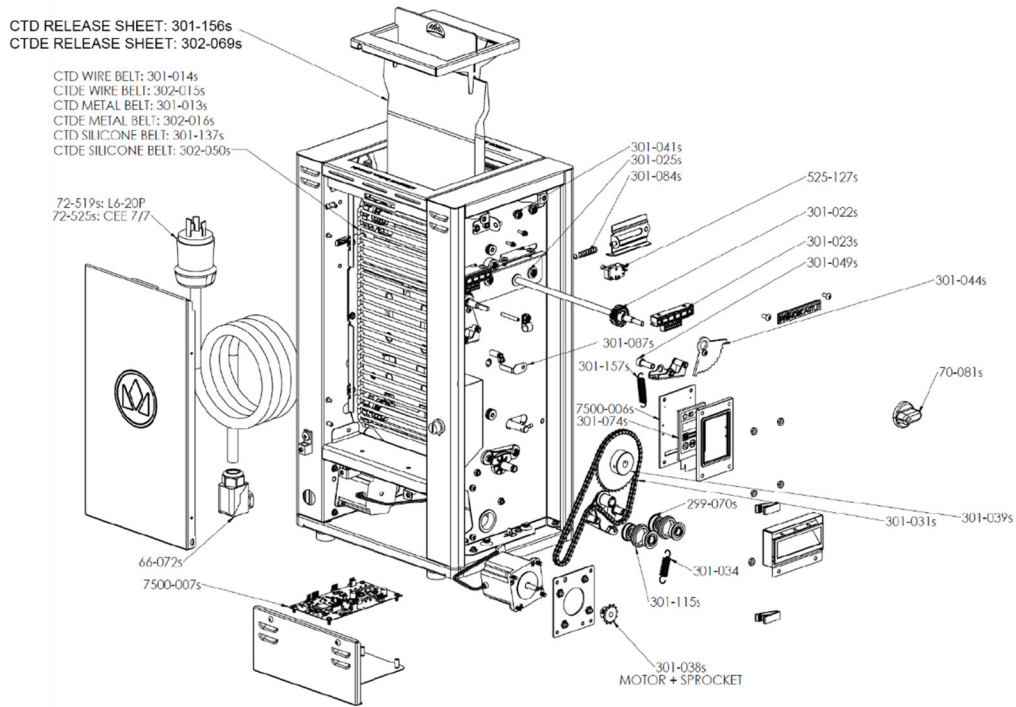

Exploded Views (continued)

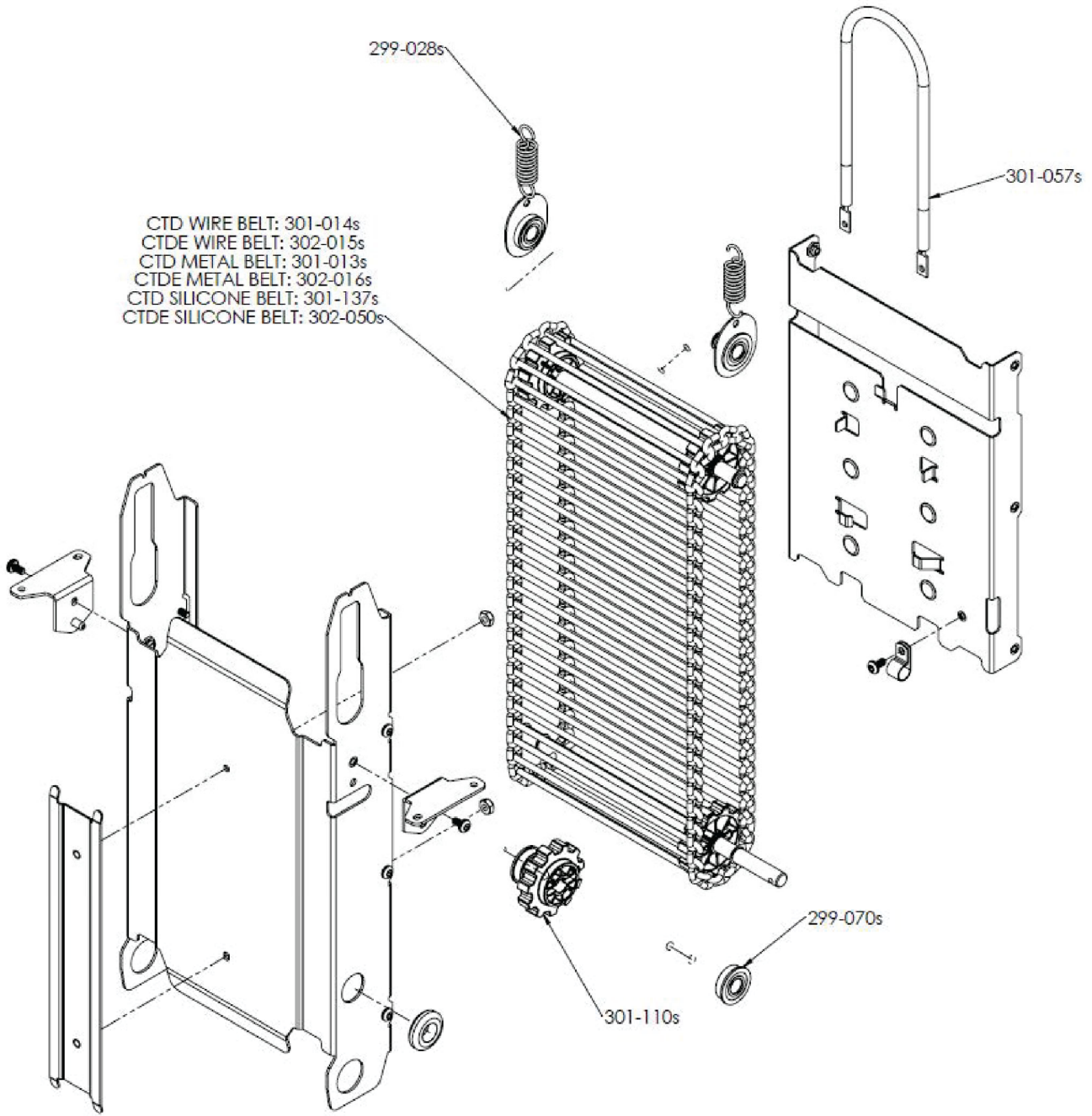

Exploded Views (continued)

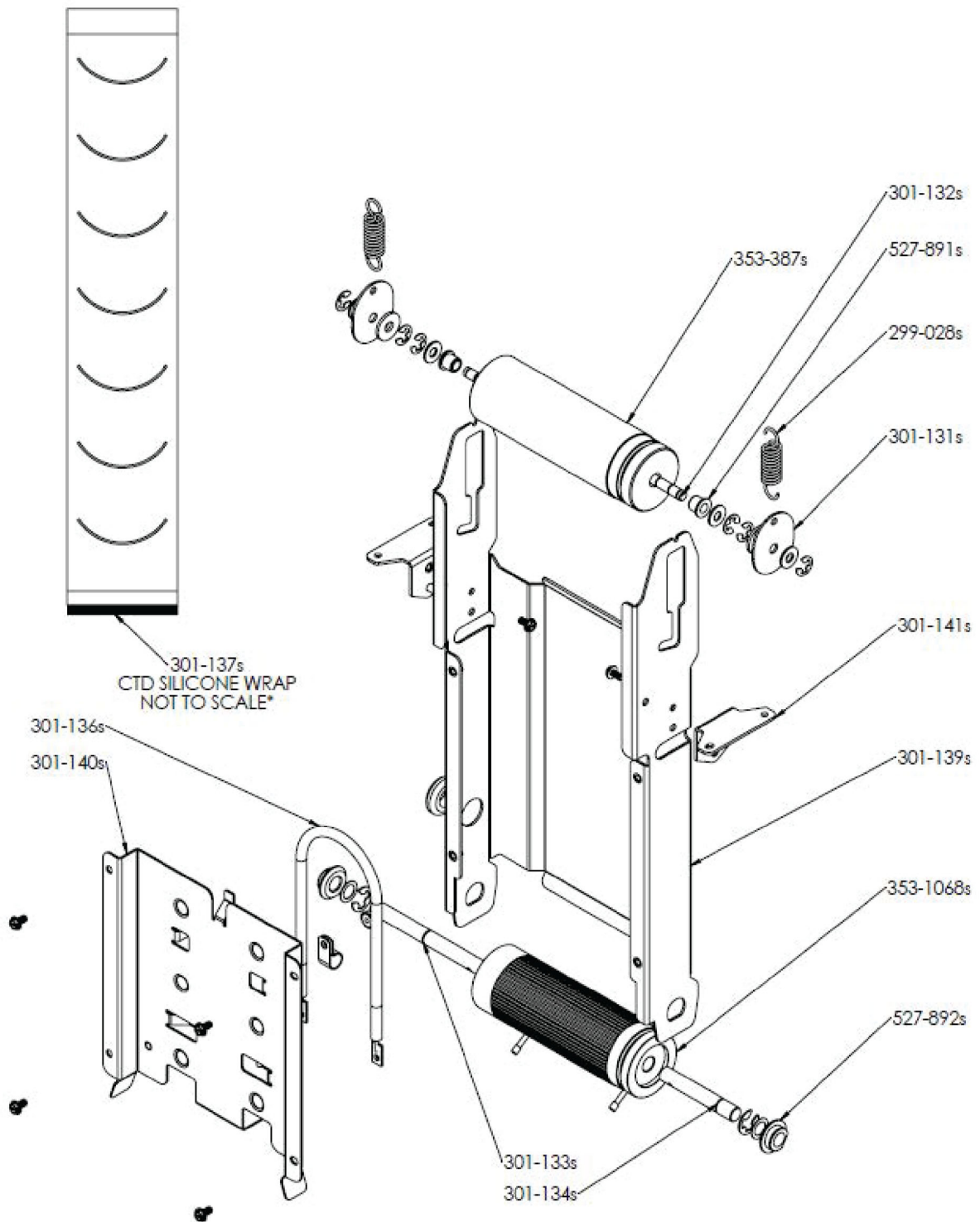

Exploded Views (continued)

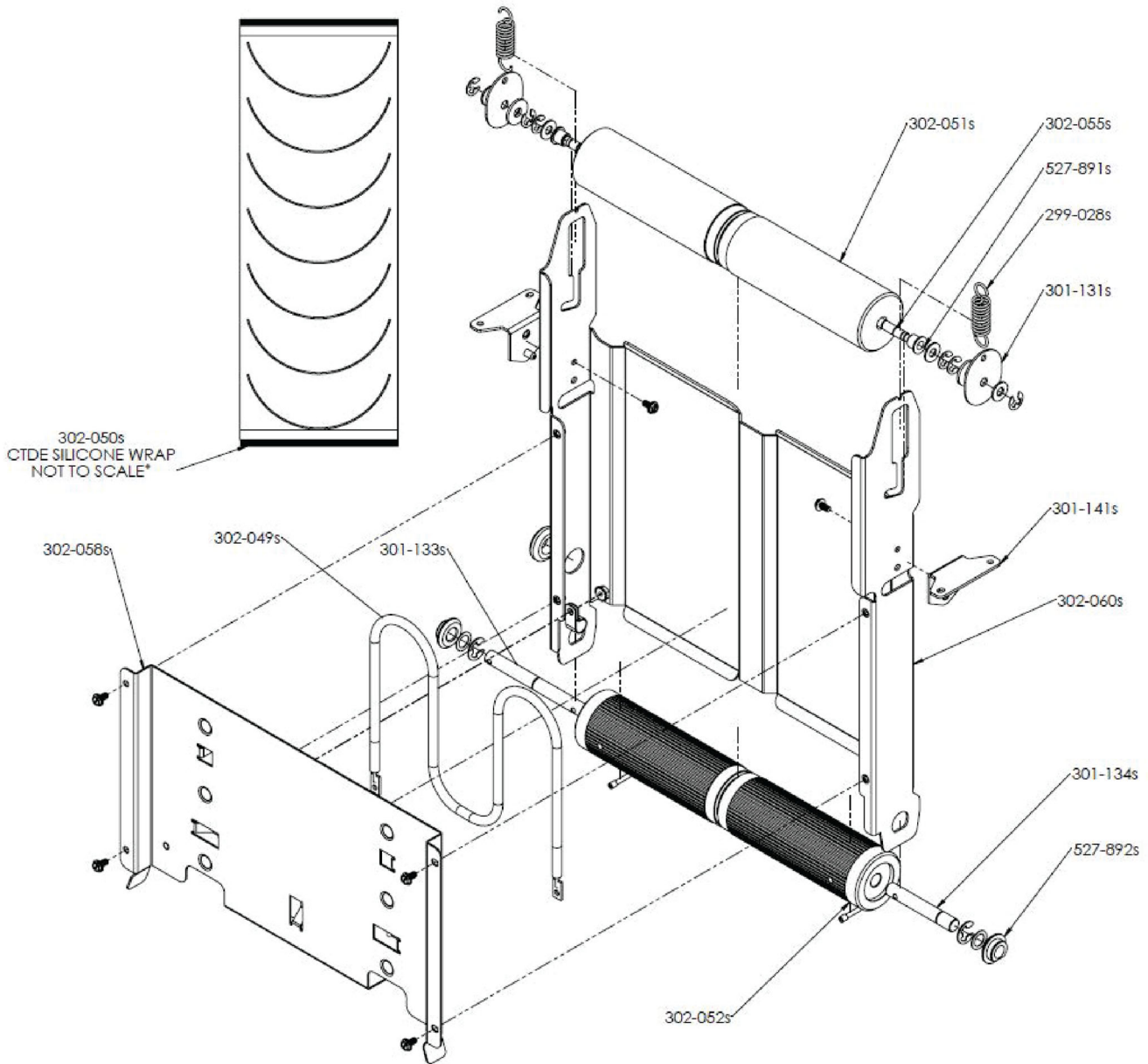

Wiring Diagram

