



**CAUTION: Read Instructions before installing and using appliance**

# Original Instructions Operation Manual



# CTD & CTDE Vertical Contact Toasters



### The CTD Series Vertical Contact Toaster

This appliance is designed for toasting bread products in a commercial kitchen. Customer-adjustable features include:

- Bun Compression Adjustment
- Set Point Temperature
- Time (Speed of Conveyor)

The Conveyor Belt options may be wire, metal (Stainless Steel) or silicone.

### LIMITED WARRANTY

This product is warranted to be free from defects in material and/or workmanship for a period of one (1) year from date of original installation, not to exceed 18 months from date of shipment from our factory. Any part or component which proves to be faulty in material and/or workmanship within the warranty period will be replaced or repaired (at the option of Prince Castle LLC) without cost to the customer for parts or labor.

This warranty is subject to the following exceptions/conditions:

- Use of any non-genuine Prince Castle parts voids this warranty and all work must be performed by an authorized Prince Castle Service Agent.
- All labor shall be performed during regular work hours. Overtime premium will not be covered.
- Travel charges are limited to 100 miles (200 kilometers) round trip, 2 hours travel time, one trip per repair.
- Damage caused by carelessness, neglect, and/or abuse (e.g., using wrong current, dropping, tampering with or altering electrical components, or improper cleaning) is not covered.
- Equipment damaged in shipment, by fire, flood or an act of God is not covered.
- Damage to non-stick coated surfaces is not covered by this warranty.

### TABLE OF CONTENTS

Safety Information .....	2
Safety Features .....	2
Electrical Specifications .....	2
Installation .....	2
Operation .....	4
Setting Adjustments .....	5
Manager Advanced Programming .....	7
Cool Down.....	9
Daily Planned Maintenance .....	9
Troubleshooting .....	11
Uninstalling and Installing the Silicone Belt.....	12
Accessories.....	13
Service Kits .....	14
Exploded Views.....	17
Wiring Diagram .....	18
Revision Log .....	19



355 East Kehoe Blvd. • Carol Stream, IL 60188 USA  
Telephone: 630-462-8800 • Toll Free: 1-800-PCASTLE  
Fax: 630-462-1460 • www.princecastle.com



## Safety Information



### WARNING

Indicates information important to the proper operation of the unit. Failure to observe may result in damage to the equipment and/or severe bodily injury or death.



### CAUTION

Indicates information important to the operation of the unit. Failure to observe may result in damage to the equipment.

**IMPORTANT: Prince Castle reserves the right to change specifications and product design without notice. Such revisions do not entitle the buyer to corresponding changes, improvements, additions or replacements for previously purchased equipment.**

## Safety Features

The CTD & CTDE Vertical Contact Toasters include the following safety features:

- If a unit becomes too hot, it shuts down.
- If one of the conveyor doors is open during operation, both conveyors turn off and an alert screen appears.



## Electrical Specifications

Model Number	Description	Volts	Hz	Watts	Amps
CTD-W	Toaster [Wire Belt]	208-240	50/60	1500-2000	8.33
CTD-M	Toaster [Metal Belt]	208-240	50/60	1500-2000	8.33
CTD-WS	Toaster [Silicone Belt]	208-240	50/60	1500-2000	8.33
CTD-W-CE	Toaster [Wire Belt]	220-240	50/60	1650-2000	8.33
CTD-M-CE	Toaster [Metal Belt]	220-240	50/60	1650-2000	8.33
CTD-WS-CE	Toaster [Silicone Belt]	220-240	50/60	1640-2000	8.33
CTDE-W	Toaster [Wire Belt]	208-240	50/60	2255-3000	12.5
CTDE-M	Toaster [Metal Belt]	208-240	50/60	2255-3000	12.5
CTDE-WS	Toaster [Silicone Belt]	208-240	50/60	2255-3000	12.5
CTDE-W-CE	Toaster [Wire Belt]	220-240	50/60	3000	13
CTDE-M-CE	Toaster [Metal Belt]	220-240	50/60	3000	13
CTDE-WS-CE	Toaster [Silicone Belt]	220-240	50/60	3000	13
XXX-XX-AX	Auxiliary Heater*	208-240	50/60	200-250	1.04

\* To add an Auxiliary Heater, insert (AX) after belt type [i.e., CTD-WAX].

## Installation



### WARNING

The appliance is not intended for use by persons (including children) with reduced physical, sensory or mental capabilities, or lack of experience and knowledge, unless they have been given supervision or instruction concerning use of the appliance by a person responsible for their safety. Children shall not be allowed to use or play with this appliance.

**1**

- Unpack and inspect.** Remove the unit from the carton and inspect for signs of damage. If there is damage to the unit:
- Notify the carrier within 24 hours of delivery.
  - Save carton and packaging materials for inspection purposes.
  - Contact your local dealer, or if purchased directly, the Prince Castle Sales Department at 1-800-722-7853 or 630-462-8800 to arrange for a replacement unit.

**2**

**Verify parts.** Verify that all parts have been received:

- CTD or CTDE Contact Toaster.
- Release Sheet Kit.
- Bun Infeed.

**3**

**Place toaster on flat surface.** Remove blue and/or white protective covering.



### CAUTION

**Two person lift, unit weight:**

- CTD, >56 lbs (25 kg)
- CTDE, >75 lbs (34 kg)

**Installation (continued)**

**CAUTION**  
 Equipment must be elevated from the floor at all times during cleaning and operation.

**4** Remove bun infeed by lifting from toaster. Remove any packing material.



**5** Open the conveyor doors. For each door, lift slightly from the bottom to unlatch and guide down to the surface. Remove any packing material.

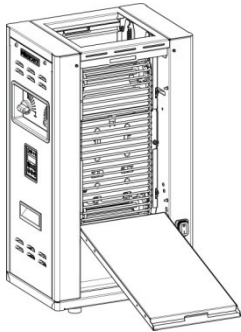

**6** Clean the bun infeed, conveyors and inside of the doors. Put on neoprene gloves. Dampen a clean cloth with lukewarm soap and water. Wipe the conveyor, rotating it as you clean to reach its entire surface. Wipe the infeed and inside of the doors. Wipe down each part again with a fresh, clean, sanitized cloth.

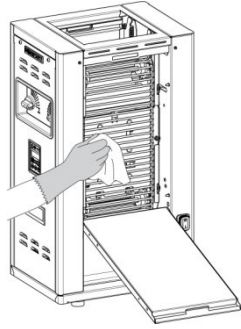

**7** Close the conveyor doors.

**8** Clean the outside of the toaster. Using a clean cloth with lukewarm soap and water, wipe the outside of the entire toaster. Wipe again with a fresh, clean, sanitized cloth.



**9** Install release sheet. Hang the folded Teflon release sheet, straddling the platen.

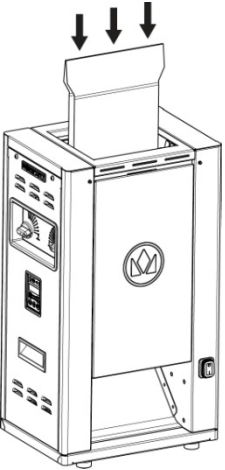

**10** Reinstall the bun infeed.

**11** Plug unit in. Plug unit into a grounded receptacle with a matching plug configuration.

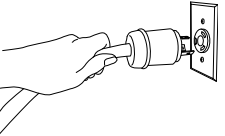

**WARNING**  
 All electrical connections must be in accordance with local electrical codes and any other applicable codes.  
 This appliance can be used by children aged from 8 years and above and persons with reduced physical, sensory or mental capabilities or lack of experience and knowledge if they have been given supervision or instruction concerning use of the appliance in a safe way and understand the hazards involved. Children shall not play with the appliance.

## Operation

- 1 Turn unit on.** Turn the On/Off switch, located on the lower right side, toward the back, to the On position.



The Prince Castle logo and version information will appear in the display.



- 2 Wait through warm-up.** On the Warm-Up screen, you can view the current recipe setting (none or 1 – 4), the set point temperature, and the current platen temperature as the unit warms. The thermometer icon will be flashing.

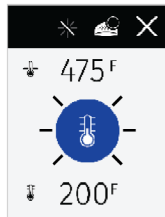

You can pause warm-up by pressing the thermometer icon if you want to change the set point. The Run/Home screen will appear. To change the set point:

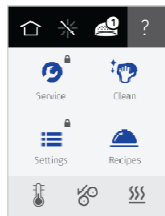

- Press the thermometer icon on the bottom of the Run/Home screen. The Edit Run Parameters screen will appear.
- Press the Plus (+) symbol to increase the set point or the Minus (-) symbol to decrease the set point.
- Press the check mark to accept the setting. The Warm-Up screen reappears and warm-up continues.

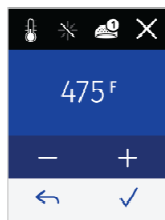

**NOTE:** If you don't want to accept the change, you can wait a minute and the Warm-Up screen reappears and warm-up continues.

- 3** **WARNING**

**BURN/ELECTRICAL SHOCK HAZARD!** Platen area is HOT and can cause severe burns or severe shock. Keep hands and objects out of the toaster unit! Failure to exercise caution may result in serious injury! Follow the Cool Down procedure before touching or working on internal apparatus.

When the current platen temperature reaches the set point temperature, the Run/Home screen appears.

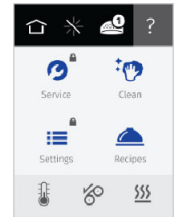

- 4 Make any desired adjustments.** Use the instructions in *Setting Adjustments* to make changes to crush adjustments, the Recipe that is running, the Temperature set point, the Time/Speed set point and the percentage of auxiliary heat (if you have that option).

- 5 Begin continuous feeding.** Feed product into top of toaster, sending the crowns down the left and the heels down the right. The sides to be toasted should face the platen, which is in the middle. Toasted product will exit at the base of the toaster.

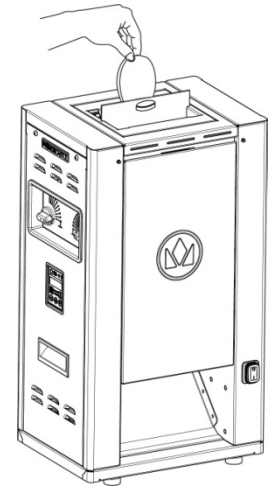

**Setting Adjustments**

**1 Change Bun Compression adjustment.** Because the platen has separate segments for the “Crown” (left) side and “Heel” (right) side, they are adjusted separately, each with its own compression control. For example, if the heels are slipping through without making good contact with the platen and look like they need more toasting, the right compression adjustment switch may need to be moved to a different letter. Or, if the crowns seem unusually thick and are being compressed too much or over-toasted, the left compression adjustment switch may need to be moved to a different number.

- Turn the left-side compression adjustment closer to “1” to allow for thicker crowns or closer to “10” for thinner crowns.
- Turn the right-side compression adjustment closer to “A” to allow for thicker heels or closer to “I” for thinner heels.

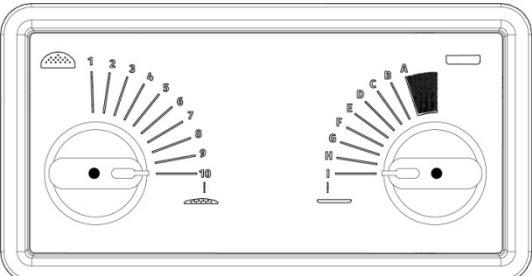

**2 Change the Recipe that is running.** The unit has four recipes to choose from. From the Run/Home screen, you can change the Recipe that is currently running.

- Press the Recipes icon on the Run/Home screen. The Recipes screen will appear.
- Press the Left arrow or Right arrow to change the recipe.
- Press the check mark to accept the change.

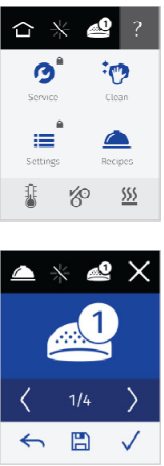

*NOTE: If you don't want to accept the change, you can press the Return arrow.*

**3 Change the Temperature set point.** From the Run/Home screen, you can change the Temperature set point.

- Press the thermometer icon on the bottom of the Run/Home screen. The Edit Run Parameters screen will appear with the current set point.
- Press the Plus (+) symbol to increase the set point or the Minus (-) symbol to decrease the set point.
- Press the check mark to accept the setting.

*NOTE: If you don't want to accept the change, you can press the Return arrow.*

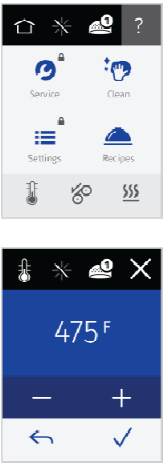

**4 Change the Time/Speed set point.** From the Run/Home screen, you can change the Time/Speed set point.  
 Range: 6-40 seconds  
 Default: 17 seconds

- Press the center icon on the bottom of the Run/Home screen. The Edit Run Parameters screen will appear with the correct set point.
- Press the Plus (+) symbol to increase the set point or the Minus (-) symbol to decrease the set point.
- Press the check mark to accept the setting.

*NOTE: If you don't want to accept the change, you can press the Return arrow.*

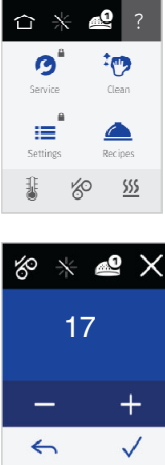

## Setting Adjustments (continued)

- 5** **Optional AUX Heater Models: Increase/Decrease the percentage of auxiliary heat.** From the Run/Home screen, you can change the percentage of auxiliary heat if your toaster has this option.

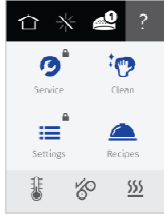

- A. Press the heat icon on the bottom of the Run/Home screen. The Edit Run Parameters screen will appear. The percentage of auxiliary heat is represented by a number from 0 to 10, where 0 is off and 10 is 100%.

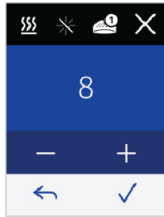

- B. Press the Plus (+) symbol to increase the setting or the Minus (-) symbol to decrease the setting.  
C. Press the check mark to accept the setting.

*NOTE: If you don't want to accept the change, you can press the Return arrow.*

- 6** **Save the current settings as the current recipe.** If you have made adjustments to the current settings and you want to save the settings to the current recipe, you can do this on the Recipe screen.

- A. Press the Recipes icon on the Run/Home screen. The Recipes screen will appear.  
B. Press the Save icon on the center bottom of the screen. (This icon will only appear if you have changed a setting.)



*NOTE: If you don't want to change the recipe, you can press the Return arrow.*

**Manager Advanced Programming**

**1 Adjust screen brightness setting.** From the Run/Home screen, you can change the screen brightness if you have a PIN.

A. Press the Settings icon on Run/Home screen. The Access Settings/Service screen will appear.



B. Type your 4-digit PIN and press the check mark. The Settings screen will appear.

C. Press the Screen Brightness icon. The Screen Brightness screen will appear. The screen brightness is represented by a setting from 1 to 10, where 10 is the brightest and 1 is the dimmest.

D. Press the Plus (+) symbol to increase the setting or the Minus (-) symbol to decrease the setting.

E. Press the check mark to accept the setting.

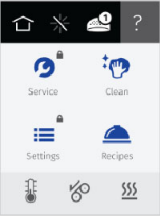
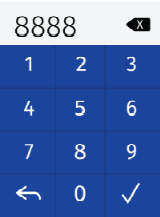
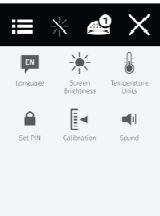
*NOTE: If you don't want to accept the change, you can press the Return arrow.*



**2 Access statistics.** From the Run/Home screen, you can access statistics if you have a PIN.

A. Press the Service icon on Run/Home screen. The Access Settings/Service screen will appear.

B. Type your 4-digit PIN and press the check mark. The Service screen will appear.

C. Press the Statistics icon. The Statistics screen will appear. The statistics screen shows relevant statistics with a timestamp.

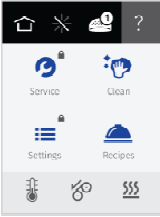
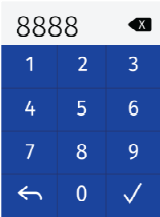
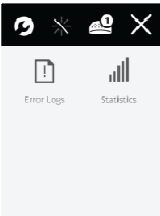
D. Press the Return arrow to return to the Run/Home screen.

**Manager Advanced Programming (continued)**

**3** **Change the temperature units (°F/°C).** From the Run/Home screen, you can change the temperature units if you have a Service PIN code.

*NOTE: You will need to obtain the Service PIN code from your service representative to access this feature.*

A. Press the Settings icon on Run/Home screen. The Access Settings/Service screen will appear.

B. Type the Service PIN code and press the check mark. The Settings screen will appear.

C. Press the Temperature Units icon. The Temperature Units screen will appear with the current setting selected.

D. Press the other setting.  
E. Press the check mark to accept the setting.

*NOTE: If you don't want to accept the change, you can press the Return arrow.*

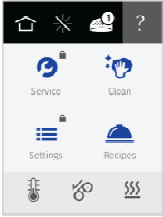
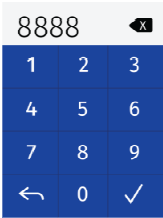
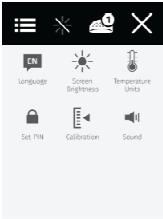
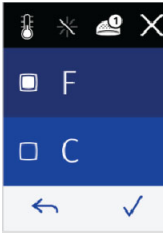
**Cool Down**

**⚠️ WARNING**  
**BURN/ELECTRICAL SHOCK HAZARD! Platen area is HOT and can cause severe burns or severe shock. Keep hands and objects out of the toaster unit! Failure to exercise caution may result in serious injury! Follow this procedure before touching or working on internal apparatus.**

**2 Wait while the toaster cools down.** The thermometer icon will be flashing until the current platen temperature reaches the cleaning set point temperature. The Cleaning icon will then appear, indicating it is okay to clean or work on the toaster.



**1 Press the Clean icon on the Run/Home screen.**

The Clean screen will appear. On the Clean screen, you can view the current platen temperature, the thermometer icon, and the cool-down temperature set point.

**Daily Planned Maintenance**

**⚠️ WARNING**  
**BURN/ELECTRICAL SHOCK HAZARD! Platen area is HOT and can cause severe burns or severe shock. Keep hands and objects out of the toaster unit! Failure to exercise caution may result in serious injury! Turn the unit off, unplug it and follow the Cool Down procedure before touching or working on internal apparatus.**

**⚠️ WARNING**  
**If the supply cord is damaged, it must be replaced by the manufacturer, its service agent, or similarly qualified person to avoid a hazard.**

**⚠️ CAUTION**  
**Do not immerse toaster in water. Do not clean with a water hose or jet spray. Do not use abrasive cleaners, pads or tools on the platen or the release sheet. Failure to exercise caution will result in damage to the unit and will not be covered by warranty. Cleaning and user maintenance shall not be made by children without supervision.**

**3 Turn the toaster off and unplug.** Turn the On/Off switch located on the lower right side, toward the back, to the Off position.

The plug removed from the outlet shall remain clearly visible to the operator during the maintenance procedure.

**1 Gather cleaning materials.** You will need clean cloths, neoprene gloves, Foodservice Safe Multipurpose Detergent Solution, sanitizer solution, and lukewarm soap and water.

**4 Remove bun infeed and release sheet.** Lay the release sheet on a flat surface.

**2 Follow the Cool Down procedure before cleaning.**

**Daily Planned Maintenance (continued)**

**5** **Open the conveyor doors.** For each door, lift slightly from the bottom to unlatch and guide down to the surface.

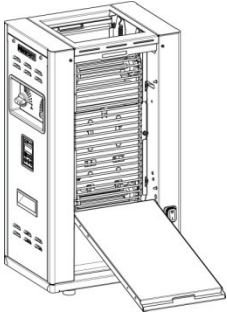

**11** **Clean outside of the toaster.** Dampen a clean cloth with lukewarm soap and water. Wipe down the outside of the entire toaster. Wipe down the entire toaster again with a fresh, clean, sanitized cloth.



**6** **Clean the release sheet.** Put on neoprene gloves. Dampen a clean cloth with lukewarm soap and water. Wipe down both sides of the release sheet, making sure all built-up sugar is removed. Wipe down both sides with a clean cloth, dampened with water, to rinse. Allow to air dry.

*NOTE: Rotate sheets daily for longer life. Depending on volume of product toasted, sheets should be replaced every 4 to 6 weeks.*



**7** **Reinstall the release sheet.**

**8** **Clean the conveyors, inside of the doors, and bun infeed.** Wipe the conveyor with a clean cloth dampened with Multipurpose Detergent Solution, rotating it as you clean to reach its entire surface. Wipe the entire surface with a clean cloth, dampened with sanitizer solution. Dampen a clean cloth with lukewarm soap and water. Wipe the inside of doors and bun infeed. Wipe the inside of the doors and bun infeed again with a fresh, clean, sanitized cloth.

**CAUTION**

**Do not use abrasive cleaners or pads on the conveyor surface.**

**9** **Close the conveyor doors.**

**10** **Reinstall the bun infeed.**

**Troubleshooting**



**WARNING**  
 To avoid possible personal injury and/or damage to the unit, inspection, test and repair of electrical equipment should be performed by qualified service personnel. The unit should be unplugged when servicing, except when electrical tests are required. Use extreme care during electrical circuit tests. Live circuits will be exposed.



**BURN/ELECTRICAL SHOCK HAZARD!** Platen is **HOT** and can cause severe burns or severe shock. Keep hands and objects out of the toaster unit! Failure to exercise caution may result in serious injury! Turn the unit off, unplug it and let it cool down completely before touching or working on internal apparatus. The plug removed from the outlet shall remain clearly visible to the operator during the maintenance procedure.

PROBLEM	POSSIBLE CAUSE	SOLUTION
Unit has no power	Unit unplugged	Plug unit in.
	Breaker tripped	Reset breaker.
	Loose connection on power switch	Call Tech Support 1-800-722-7853
	Inoperable power switch	
Unit will not heat up	Loose connection on platen	Call Tech Support 1-800-722-7853
	Open platen	
	Loose connection to the main control board	
	Inoperable main control board	
	Inoperable TRIAC	
Unit heats up, but the conveyors do not run	The conveyor door is ajar	Verify that the door is closed.
	Inoperable motor	Call Tech Support 1-800-722-7853
	Stripped drive gear	
	Stripped conveyor gear	
	Jammed conveyor assembly	
Not toasting properly (under- or over-done)	Inoperable RTD-probe	Call Tech Support 1-800-722-7853
	Improper set point	Adjust set point in programming (see <i>Setting Adjustments</i> section).
	Improper compression	Adjust compression (see <i>Setting Adjustments</i> section).
	Torn or soiled release sheet	Clean or replace release sheet.
	Bad platen	Call Tech Support 1-800-722-7853
Jumpy or blank display	Improper ground	Call Tech Support 1-800-722-7853
	Inoperable display	
	Inoperable main control board	
	Loose wiring harness	
E01 error code visible on display	Relay shorted or open	Call Tech Support 1-800-722-7853
E02 error code visible on display	Conveyor 1 either jammed or not working	Call Tech Support 1-800-722-7853
E03 error code visible on display	Conveyor 2 either jammed or not working	Call Tech Support 1-800-722-7853
E05 error code visible on display	Set point temperature not reached in expected time	Call Tech Support 1-800-722-7853
E06 error code visible on display	Software files on USB not valid	Call Tech Support 1-800-722-7853
E07 error code visible on display	Transferred software files on external Flash not valid	Call Tech Support 1-800-722-7853
E08 error code visible on display	Temperature sensor open or shorted	Call Tech Support 1-800-722-7853
E09 error code visible on display	Current platen temperature 20°F higher than set point temperature	Call Tech Support 1-800-722-7853
E10 error code visible on display	Current platen temperature 20°F lower than set point temperature	Call Tech Support 1-800-722-7853
N1 notification visible on display	Reminder to clean	Clean unit and delete message.

NOTE: For all other problems, call approved local service agent.

## Uninstalling and Installing the Silicone Belt

**1** **Uninstall the silicone belt.** Ensure the CTD is not hot to the touch.

A. Open the conveyor door.



B. Push door switch pin to activate the conveyor until the area where the two ends of the belt meet is near the top. Release switch pin. Fold the flap back to access the two ends.



C. Unhook the two clips on the end of the belt without the flap from the wire conveyor and activate the conveyor until the unattached end of the belt is hanging free.



D. While holding the free end with one hand, keep rotating the conveyor so you can access the attached end, lift the flap and unhook the two clips on that end to free the belt.



**2** **Install the silicone belt.** Follow "Uninstall" in reverse.

**Accessories**

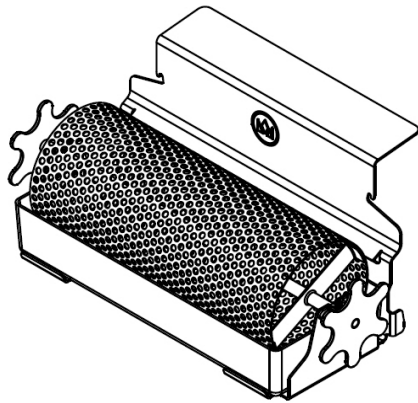

**511-142** Butter Wheel, CTD  
**511-141** Butter Wheel, CTDE

Butter Wheel  
Hanging Points

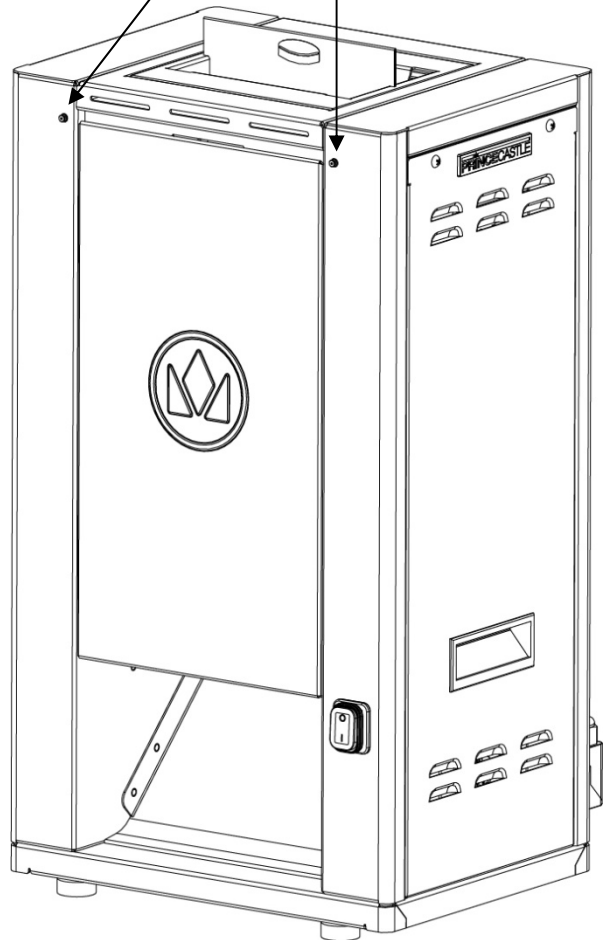

**Service Kits**

NOTE: See Exploded Views on page 17 for item location.

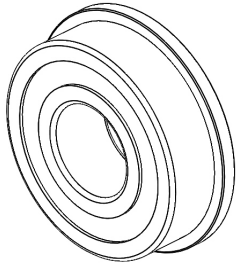
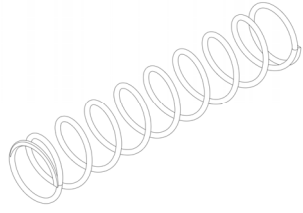
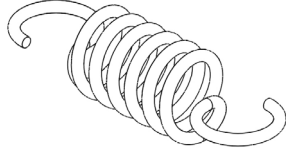
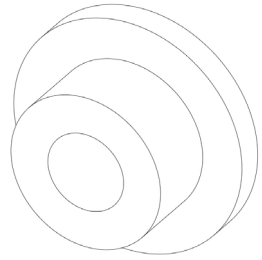
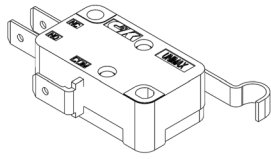
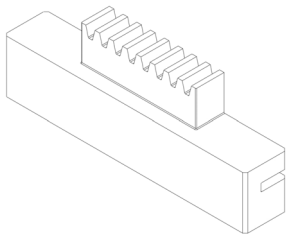
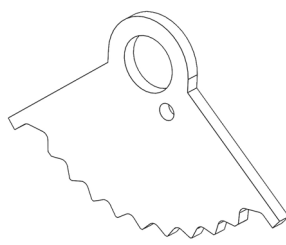
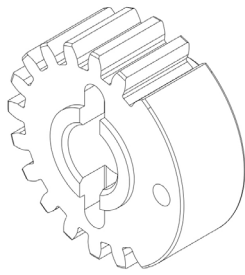
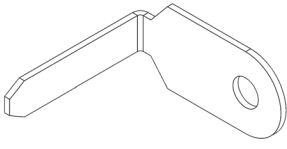
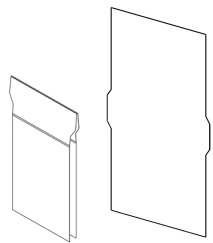
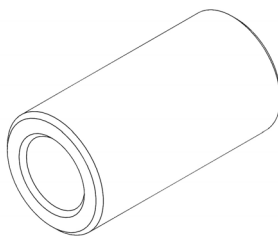
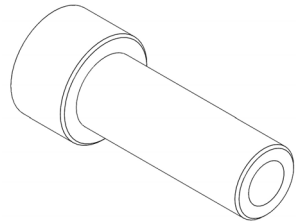
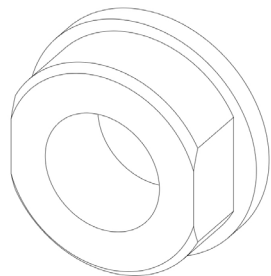
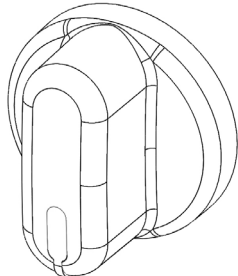
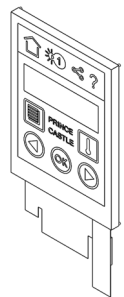
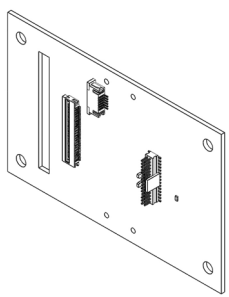
<p>1</p>  <p><b>299-070S</b> Flanged Ball Bearing</p>	<p>2</p>  <p><b>301-084S</b> Door Switch Spring</p>	<p>3</p>  <p><b>299-028S</b> Conveyor Tensioner Spring</p>	<p>4</p>  <p><b>301-041S</b> Chain Tensioner Bushing</p>
<p>5</p>  <p><b>525-127S</b> Door Cut-Off Switch</p>	<p>6</p>  <p><b>301-023S</b> Rack</p>	<p>7</p>  <p><b>301-044S</b> Indexer</p>	<p>8</p>  <p><b>301-022S</b> Gear</p>
<p>9</p>  <p><b>301-087S</b> High Limit Probe Clip</p>	<p>10</p>  <p><b>301-062S</b> (CTD)  <b>302-030S</b> (CTDE)      Release Sheet</p>	<p>11</p>  <p><b>301-046S</b> Detent Roller</p>	<p>12</p>  <p><b>301-049S</b> Detent Mechanism Bushing</p>
<p>13</p>  <p><b>301-025S</b> Compression Adjust. Sleeve Bearing</p>	<p>14</p>  <p><b>70-081S</b> Indicating Knob</p>	<p>15</p>  <p><b>301-074S</b> Display Module</p>	<p>16</p>  <p><b>7500-006S</b> LCD Adapter</p>

**Service Kits (continued)**

NOTE: See Exploded Views on page 17 for item location.

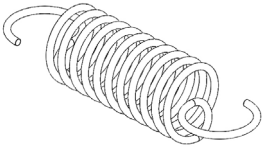
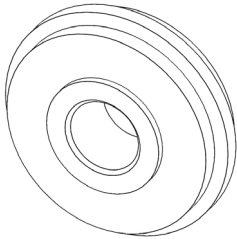
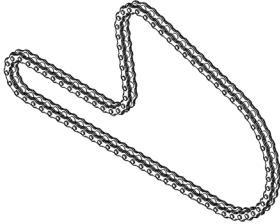
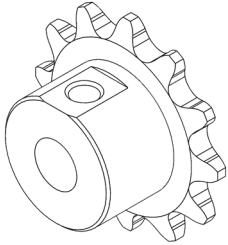
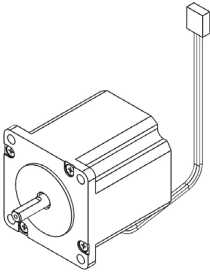
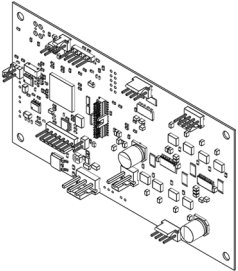
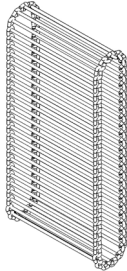
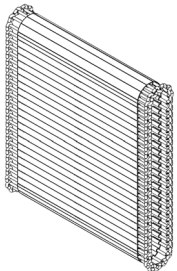
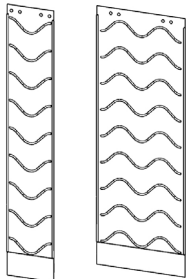
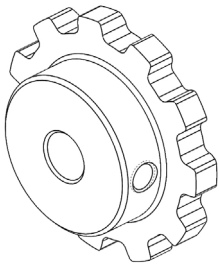
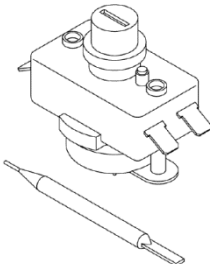
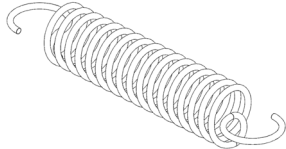
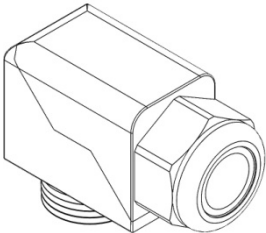
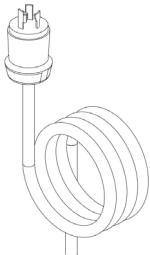
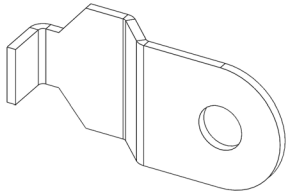
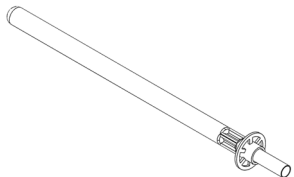
<p>17</p>  <p><b>301-035S</b> Chain Tensioner Spring</p>	<p>18</p>  <p><b>301-036S</b> Chain Tensioner Roller</p>	<p>19</p>  <p><b>301-031S</b> Drive Chain</p>	<p>20</p>  <p><b>301-038S</b> Sprocket</p>
<p>21</p>  <p><b>299-060S</b> Motor</p>	<p>22</p>  <p><b>7500-007S</b> Control Board</p>	<p>23</p>  <p><b>301-014S</b> (CTD) <b>302-015S</b> (CTDE) Wire Conveyor Belt</p>	<p>24</p>  <p><b>301-013S</b> (CTD) <b>302-016S</b> (CTDE) Tracking Conveyor Belt</p>
<p>25</p>  <p><b>301-079S</b> (CTD) <b>302-029S</b> (CTDE) Wrap-Around Belt</p>	<p>26</p>  <p><b>299-074S</b> Conveyor Sprocket</p>	<p>27</p>  <p><b>301-117S</b> Electric Thermostat</p>	<p>28</p>  <p><b>301-047S</b> Detent Mechanism Spring</p>
<p>29</p>  <p><b>66-072S</b> Cord Strain Relief Elbow</p>	<p>30</p>  <p><b>72-519S</b> U.S. L6-20P <b>72-525S</b> CEE7/7 Schuko Power Cord</p>	<p>31</p>  <p><b>301-086S</b> Temperature Probe Clip</p>	<p>32</p>  <p><b>527-468S</b> Temperature Probe</p>

**Service Kits (continued)**

NOTE: See Exploded Views on page 17 for item location.

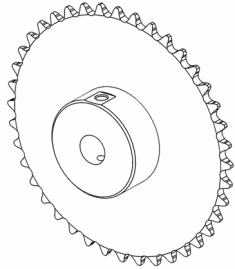
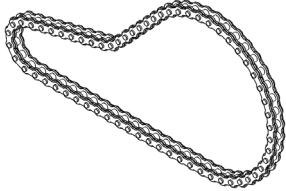
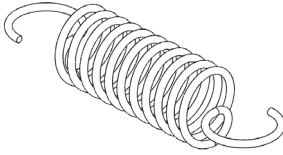
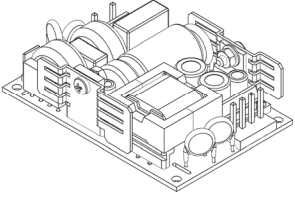
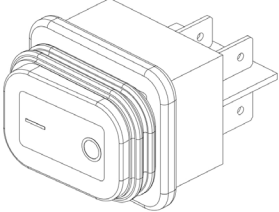
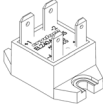
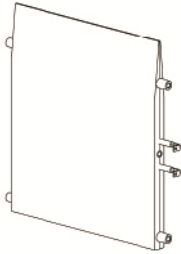
<p>33</p>  <p><b>301-039S</b> Sprocket, 1/4" Pitch x 40TH</p>	<p>34</p>  <p><b>301-030S</b> Drive Chain, ANSI 25 x 63</p>	<p>35</p>  <p><b>301-034S</b> Spring, Chain Tensioner-L</p>	<p>36</p>  <p><b>85-144-25S</b> Power Supply, ECS45US24</p>
<p>37</p>  <p><b>78-233S</b> Switch, Rocker, DPST, IP65, 16A</p>	<p>38</p>  <p><b>302-034S</b> (EL240A30-05) <b>301-077S</b> (EL240A5-05) <b>301-078S</b> (EL240A10-05) <b>302-025S</b> (EL240A20-05) Relay</p>	<p>39</p>  <p><b>301-011S</b> (CTD) <b>302-012S</b> (CTDE) Heater Platen</p>	

**Not Shown:**

<p>40</p> <p><b>88-828S</b> Filter, EMI</p>	<p>41</p> <p><b>301-090S</b> High Limit Cable</p>	<p>42</p> <p><b>301-091S</b> Harness, RTD</p>	<p>43</p> <p><b>301-092S</b> Harness, LCD</p>
<p>44</p> <p><b>301-093S</b> Harness, SSR</p>	<p>45</p> <p><b>301-094S</b> Power Harness, AC</p>	<p>46</p> <p><b>301-095S</b> Power Harness, DC</p>	<p>47</p> <p><b>301-097S</b> Wire, Neutral</p>
<p>48</p> <p><b>301-098S</b> Harness, Door Switch</p>	<p>46</p> <p><b>301-099S</b> Harness, Auxiliary Heater</p>	<p>50</p> <p><b>302-036S</b> Harness, Auxiliary Heater</p>	

**Exploded Views**

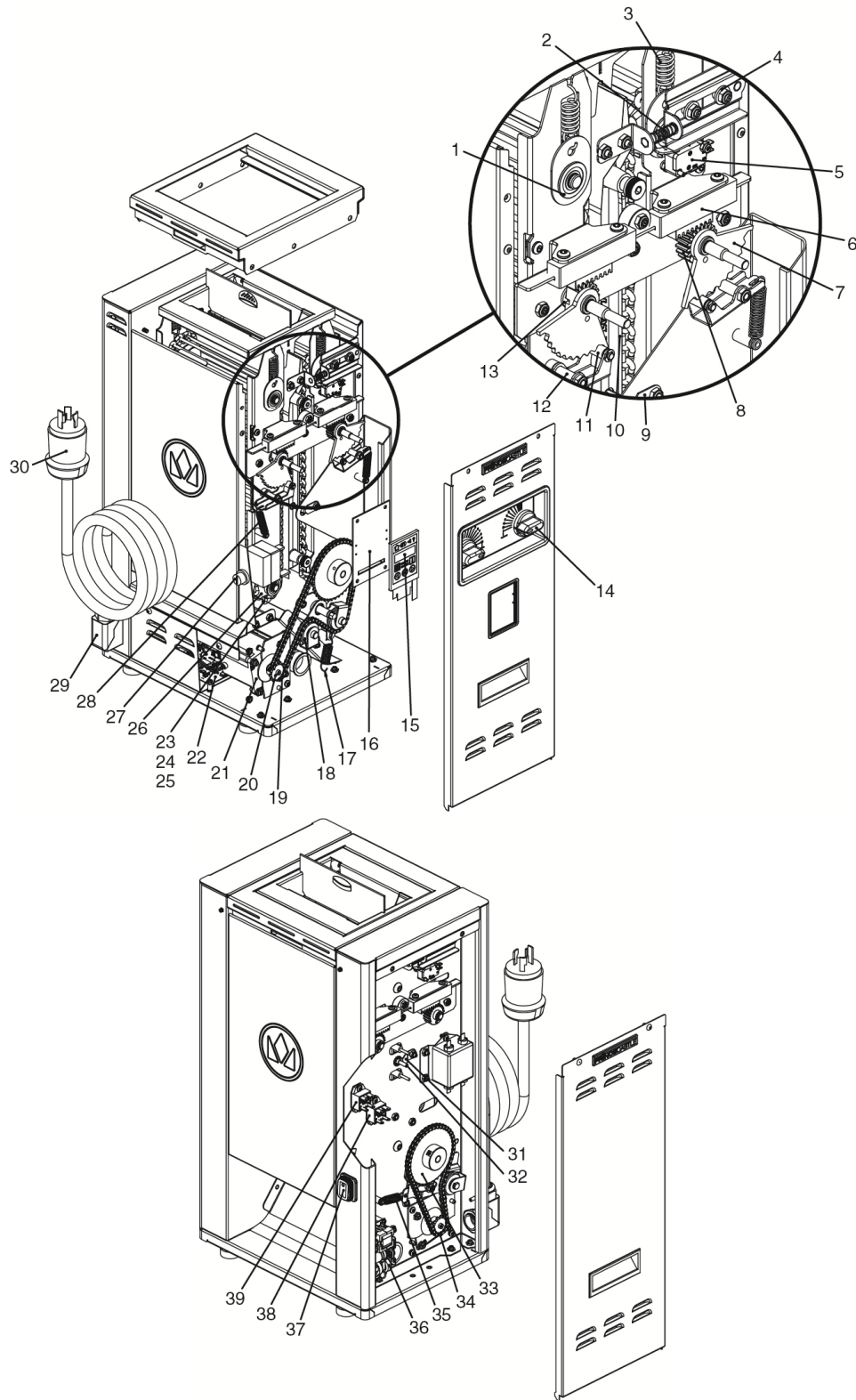

### Wiring Diagram

