

Original Instructions Operation Manual



Contact Toaster – Single-Sided CTS-W/CTS-M/CTS-WS CTS-WCE/CTS-MCE/CTS-WSCE



Contact Toaster - Single-Sided

This appliance is designed for toasting bread products in a commercial kitchen. Customer-adjustable features include:

- Crush Adjustment
- Set Temperature
- Toast Time (Speed of Conveyor)
- Scale (°F or C°)

The conveyor belt may be wire, metal (Stainless Steel) or silicone.

Silicone belt is consumable to be replaced 2-6 months dependent on usage and is not covered under warranty.



**WS - Silicone
Conveyor**



**W - Wire
Conveyor**



**M - Metal
Conveyor**

LIMITED WARRANTY

This product is warranted to be free from defects in material and/or workmanship for a period of one (1) year from date of original installation, not to exceed 18 months from date of shipment from our factory. Any part or component which proves to be faulty in material and/or workmanship within the warranty period will be replaced or repaired (at the option of Prince Castle LLC) without cost to the customer for parts or labor.

This warranty is subject to the following exceptions/conditions:

- Use of any non-genuine Prince Castle parts voids this warranty and all work must be performed by an authorized Prince Castle Service Agent.
- All labor shall be performed during regular work hours. Overtime premium will not be covered.
- Travel charges are limited to 100 miles (200 kilometers) round trip, 2 hours travel time, one trip per repair.
- Damage caused by carelessness, neglect, and/or abuse (e.g., using wrong current, dropping, tampering with or altering electrical components, or improper cleaning) is not covered.
- Equipment damaged in shipment, by fire, flood or an act of God is not covered.
- Damage to non-stick coated surfaces is not covered by this warranty.

TABLE OF CONTENTS

| | |
|--|-----------|
| Safety Information | 2 |
| Electrical Specifications | 2 |
| Installation | 2 |
| Operation | 4 |
| Setting Adjustments | 6 |
| Daily Planned Maintenance | 7 |
| Troubleshooting | 9 |
| Uninstalling and Installing the Silicone Belt | 10 |
| Service Kits | 11 |
| Accessories | 12 |
| Wiring Diagram | 13 |
| Revision Log | 14 |

PRINCECASTLE™

MARMON FOODSERVICE TECHNOLOGIES
A BERKSHIRE HATHAWAY COMPANY

355 East Kehoe Blvd. • Carol Stream, IL 60188 USA
Telephone: 630-462-8800 • Toll Free: 1-800-PCASTLE
Fax: 630-462-1460 • www.princecastle.com



Safety Information

WARNING

Indicates information important to the proper operation of the unit. Failure to observe may result in damage to the equipment and/or severe bodily injury or death.

CAUTION

Indicates information important to the operation of the unit. Failure to observe may result in damage to the equipment.

IMPORTANT: Prince Castle reserves the right to change specifications and product design without notice. Such revisions do not entitle the buyer to corresponding changes, improvements, additions or replacements for previously purchased equipment.

Electrical Specifications

CTS-W/CTS-M/CTS-WS: 120V, 60 Hz, 12.5A, 1500W, NEMA-5-15 Plug

CTS-WCE/CTS-MCE/CTS-WSCE: 240V, 50 Hz, 6.25A, 1500W, CEE7-7 Plug

Installation

- 1 Unpack and inspect.** Remove the unit from the carton and inspect for signs of damage. If there is damage to the unit:
- Notify the carrier within 24 hours of delivery.
 - Save carton and packaging materials for inspection purposes.
 - Contact your local dealer, or if purchased directly, the Prince Castle Sales Department at 1-800-722-7853 or 630-462-8800 to arrange for a replacement unit.

- 2 Verify parts.** Verify that all parts have been received:
- Dual Continuous Feed Toaster with conveyor.
 - Release Sheet Kit.
 - Bun Infeed.

- 3 Place toaster on flat surface.** Remove blue and/or white protective covering.

CAUTION

Two person lift, unit weight >68 lbs (31 kg).

- 4 Remove packing.** Remove any packing material and tape.

CAUTION

Equipment must be elevated from the floor at all times during cleaning and operation.

- 5 Remove bun infeed by lifting from toaster.**

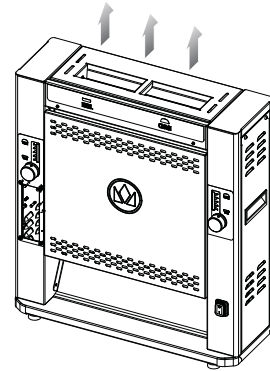

- 6 Remove the conveyor.** Use handle to lift the conveyor up and away from CTS. Lay it on a clean surface with the flat side down.

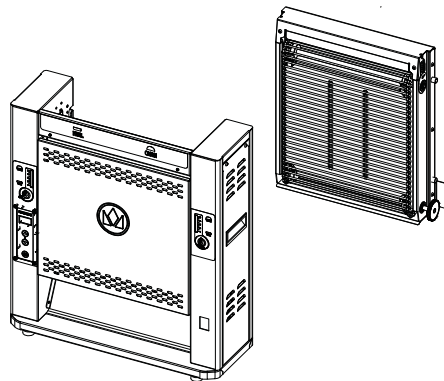

Note: CTS-WS and CTS-WSCE Model conveyors may require installation of the silicon belt. Refer to Uninstalling and Installing the Silicon Belt.

Installation (continued)

7 Clean the bun infeed, conveyor and CTS. Put on neoprene gloves. Dampen a clean cloth with lukewarm soap and water. Wipe the conveyor, rotating it as you clean to reach its entire surface. Wipe the infeed and outside of the entire CTS. Wipe down each part and outside of the CTS again with a fresh, clean, sanitized cloth.

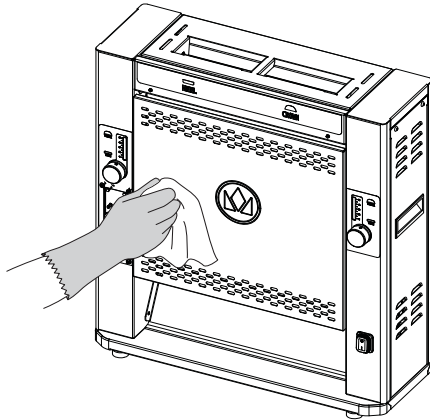

8 Install release sheet. Hang the Teflon release sheet over the platen, holding it with one hand. Place the holding clamp (P/N 299-057) on top of it.

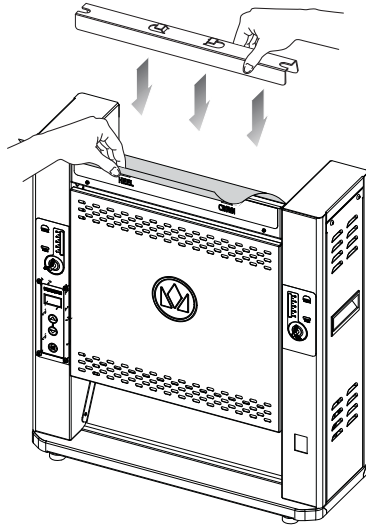

9 Reinstall the conveyor. Using the handle to lift the conveyor, line up the side posts of the conveyor with their notches on the CTS. Move the conveyor into the CTS and gently release.

10 Reinstall the bun infeed.

11 Plug unit in. Plug unit into a grounded receptacle with a matching plug configuration.

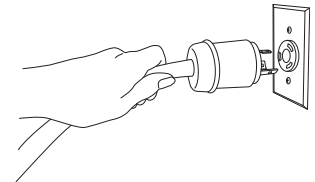

WARNING

All electrical connections must be in accordance with local electrical codes and any other applicable codes.

This appliance can be used by children aged from 8 years and above and persons with reduced physical, sensory or mental capabilities or lack of experience and knowledge if they have been given supervision or instruction concerning use of the appliance in a safe way and understand the hazards involved. Children shall not play with the appliance.

Operation

1 Turn unit on. Turn the On/Off switch located on the lower right to the On position. The version information will appear in the display for 3 seconds.

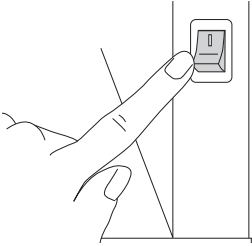

2 Wait through warm-up. During warm-up, the display will read "WARMING UP". Warm-up time is about 15-20 minutes.

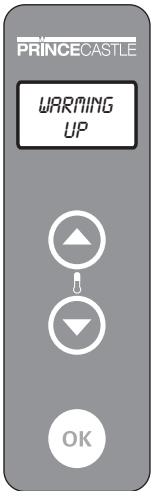

3 **WARNING**
BURN/ELECTRICAL SHOCK HAZARD! Platen area is **HOT** and can cause severe burns or severe shock. Keep hands and objects out of the toaster unit! Failure to exercise caution may result in serious injury! Turn the unit off, unplug it and let it cool down completely before touching or working on internal apparatus.

Watch for **READY** status. When temperature is reached, the display will read "READY".

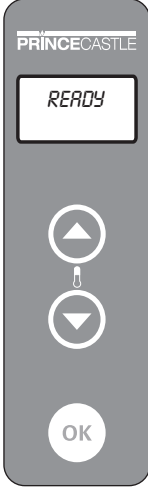

4 View status. Each press on the down arrow button will scroll through the actual temperature, the set temperature and the amount of time the CTS has been on ("runtime").



Operation (continued)

- 5** **Make any desired adjustments.** Use the instructions in *Setting Adjustments* to make changes to the crush adjustment, the set temperature, the temperature scale and/or the time it takes to toast.

- 6** **Begin continuous feeding.** Feed product into top of CTS, sending the correct product parts down the left and right sides of the unit. The sides to be toasted should face the platen, which is in the front. Toasted product will exit at the base of the CTS.

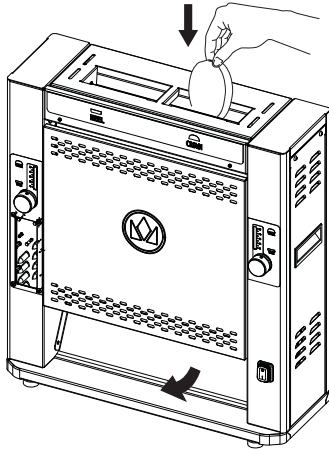

Setting Adjustments

1 **Change crush adjustment.** Because the platen has separate segments for the left (“Heel” side) and right (“Crown” side - usually thicker), they are adjusted separately, each with its own crush adjustment knob. For example, if the heels are slipping through without making good contact with the platen and look like they need more toasting, the left crush adjustment knob may need to be moved more toward “Thin”. Or, if the crowns seem unusually thick and are being crushed too much or over-toasted, the right crush adjustment knob may need to be moved more toward “Thick”.

A. Turn the left-side crush adjustment knob clockwise to allow for thicker heels or counterclockwise for thinner heels. *NOTE: Watch the bar to keep track of how much you have changed the setting.*

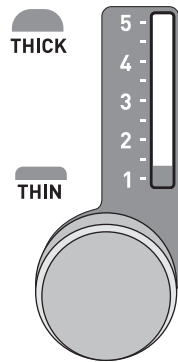

B. Turn the right-side crush adjustment knob clockwise to allow for thicker crowns or counterclockwise for thinner crowns.

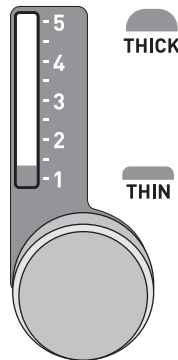

2 **Change the set temperature, temperature scale and/or time that it takes to toast.**

A. From a screen that says “READY”, press and hold the OK button for 3 seconds.

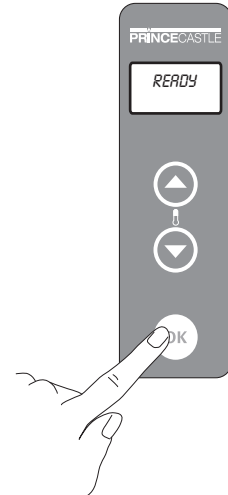

B. The screen displays “TEMP” and gives the set temperature. Change the set temperature using the up and down arrow buttons, or don't change it if it is already correct. To accept the set temperature, press OK.



C. The screen displays “TemScale F/C” with a black box over either the “F” (meaning the scale is Fahrenheit) or the “C” (meaning the scale is Celsius). Change the temperature scale using the up and down arrow buttons, or don't change it if it is already correct. To accept the temperature scale, press OK.



D. The screen displays “TIME” and gives the time it takes to toast in seconds. Change the time it takes to toast using the up and down arrow buttons, or don't change it if it is already correct. To accept the time it takes to toast, press OK.



Daily Planned Maintenance

⚠ WARNING
BURN/ELECTRICAL SHOCK HAZARD! Platen area is **HOT** and can cause severe burns or severe shock. Keep hands and objects out of the toaster unit! Failure to exercise caution may result in serious injury! Turn the unit off, unplug it and let it cool down completely before touching or working on internal apparatus.

⚠ WARNING
 If the supply cord is damaged, it must be replaced by the manufacturer, its service agent, or similarly qualified person to avoid a hazard.

⚠ CAUTION
 Do not immerse toaster in water. Do not clean with a water hose or jet spray. Do not use abrasive cleaners, pads or tools on the platen or the release sheet. Failure to exercise caution will result in damage to the unit and will not be covered by warranty. Cleaning and user maintenance shall not be made by children without supervision.

1 **Gather cleaning materials.** You will need clean cloths, neoprene gloves, Multipurpose Detergent Solution, sanitizer solution, and lukewarm soap and water.

2 **Turn CTS off.** Turn the On/Off switch located on the lower right to the Off position.

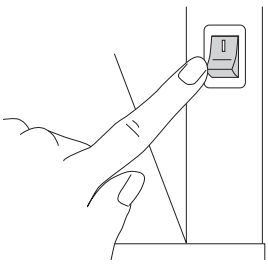

3 **Unplug and let cool.** Allow platen to cool for 60 minutes before cleaning. The plug removed from the outlet shall remain clearly visible to the operator during the maintenance procedure.

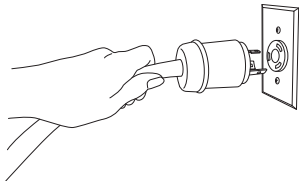

4 **Remove bun infed by lifting from toaster.**

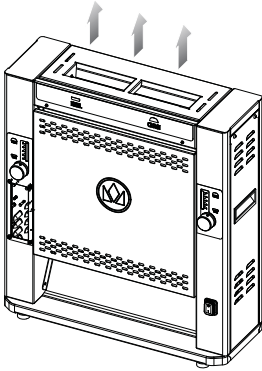

5 **Remove the conveyor.** Use handle to lift the conveyor up and away from CTS. Lay it on a clean surface with the flat side down.

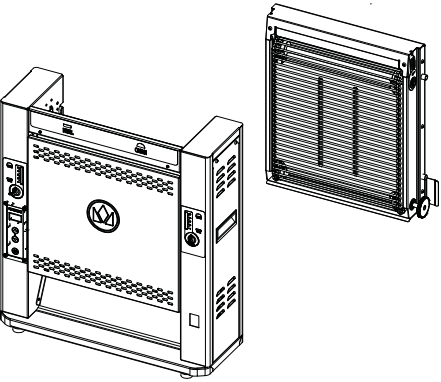

6 **Remove the release sheet.** Lay the release sheet on a flat surface.

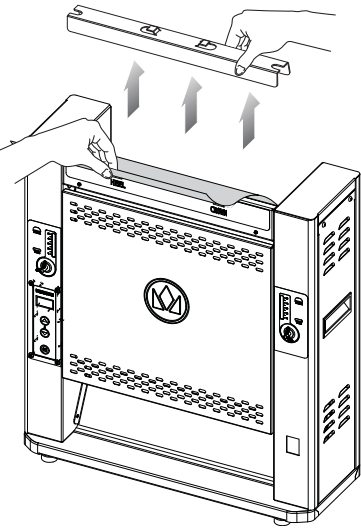

Daily Planned Maintenance (continued)

7 **Clean the release sheet.** Dampen a clean cloth with lukewarm soap and water. Wipe down both sides of the release sheet, making sure all built-up sugar is removed. Wipe down both sides with a clean cloth, dampened with water, to rinse. Allow to air dry. *NOTE: Rotate sheets daily for longer life. Depending on volume of product toasted, sheets should be replaced every 4 to 6 weeks.*

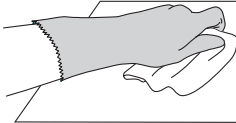

8 **Reinstall the release sheet.**

9 **Clean the conveyor.** Put on neoprene gloves. Wipe the conveyor with a clean cloth dampened with Multipurpose Detergent Solution, rotating it as you clean to reach its entire surface. Wipe the entire surface with a clean cloth, dampened with sanitizer solution.



CAUTION

Do not use abrasive cleaners or pads on the conveyor surface.

10 **Reinstall the conveyor.** Using the handle to lift the conveyor, line up the side posts of the conveyor with their notches on the CTS. Move the conveyor into the CTS and gently release.

11 **Reinstall the bun infeed.**

12 **Clean outside of the CTS.** Dampen a clean cloth with lukewarm soap and water. Wipe down the outside of the entire CTS. Wipe down the entire CTS again with a fresh clean, sanitized cloth.

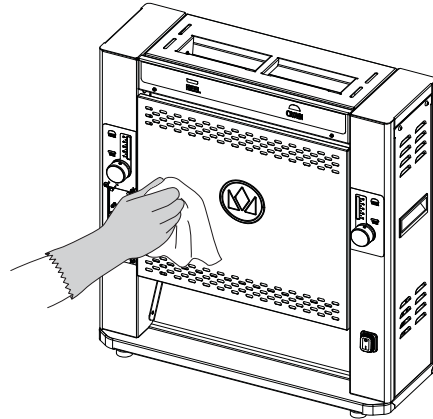

Troubleshooting



WARNING
BURN/ELECTRICAL SHOCK HAZARD! Platen is HOT and can cause severe burns or severe shock. Keep hands and objects out of the toaster unit! Failure to exercise caution may result in serious injury! Turn the unit off, unplug it and let it cool down completely before touching or working on internal apparatus. The plug removed from the outlet shall remain clearly visible to the operator during the maintenance procedure.

| PROBLEM | POSSIBLE CAUSE | SOLUTION |
|--|--|---|
| Unit has no power | Unit unplugged | Plug unit in. |
| | Breaker tripped | Reset breaker. |
| | Loose connection on power switch | Call Tech Support 1-800-722-7853 |
| | Inoperable power switch | |
| Unit will not heat up | Loose connection on platen | Call Tech Support 1-800-722-7853 |
| | Open platen | |
| | Loose connection to the main control board | |
| | Inoperable main control board | |
| | Inoperable TRIAC | |
| Unit heats up, but the conveyor does not run | Inoperable motor | Call Tech Support 1-800-722-7853 |
| | Stripped drive gear | |
| | Stripped conveyor gear | |
| | Jammed conveyor assembly | |
| Not toasting properly (under- or over-done) | Inoperable RTD-probe | Call Tech Support 1-800-722-7853 |
| | Improper set point | Adjust set point in programming (see <i>Setting Adjustments</i> section). |
| | Improper compression | Adjust compression (see <i>Setting Adjustments</i> section). |
| | Torn or soiled release sheet | Clean or replace release sheet. |
| | Bad platen | Call Tech Support 1-800-722-7853 |
| Jumpy or blank display | Improper ground | Call Tech Support 1-800-722-7853 |
| | Inoperable display | |
| | Inoperable main control board | |
| | Loose wiring harness | |

NOTE: For all other problems, call approved local service agent.

Uninstalling and Installing the Silicone Belt

IMPORANT: Belt is consumable that must be replaced every 2-6 months, dependent on usage and wear.

1 Uninstall the silicon belt. Ensure the CTS is off and not hot to the touch.

A. Remove the conveyor. Use handle on back to lift the conveyor up and away from CTS. Lay it on a clean surface with the flat side (back) down.

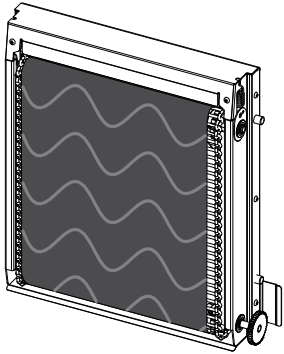

B. Rotate the conveyor until the area where the two ends of the belt meet is near the top. Fold the flap back to access the two ends.

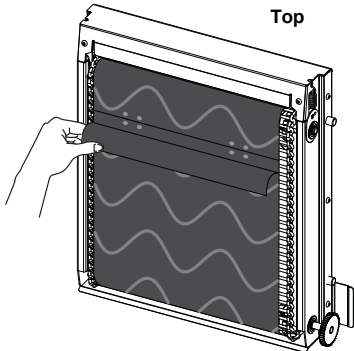

C. Unhook the two clips on the end of the belt without the flap from the wire conveyor and rotate the conveyor towards the top until the unattached end of the belt is hanging free.

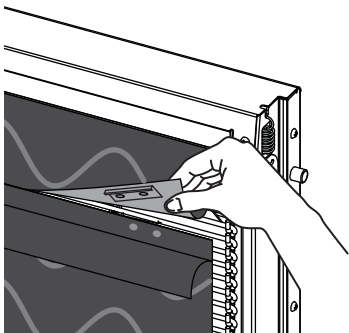

D. While holding the free end with one hand, rotate the conveyor back toward the bottom so you can access the attached end, lift the flap and unhook the two clips on that end to free the belt.

2 Install the silicon belt.

A. Locate the end of the belt that has the flap.

B. With the flap positioned toward the top of the conveyor, fold back the flap and hook the two clips onto any wire on the conveyor.

C. While holding the silicon belt with one hand, slowly rotate the conveyor toward the top until the attached end is near the top again.

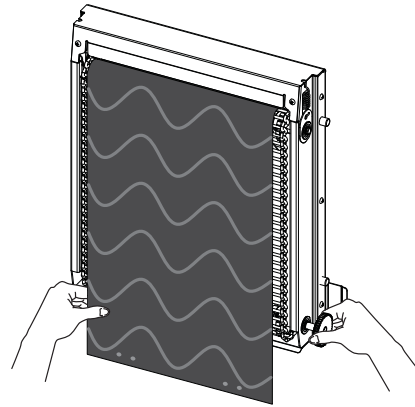



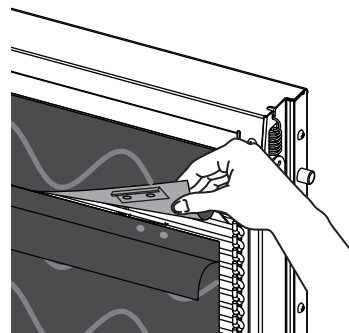



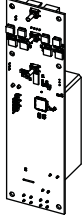
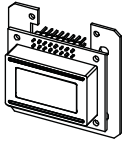
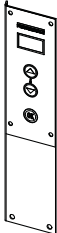
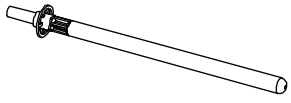

D. Folding the flap on the attached end back, hook the two clips on the free end of the belt onto the wire conveyor so the two ends meet. Release the flap.

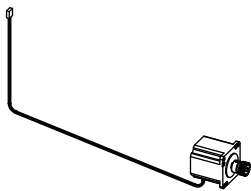

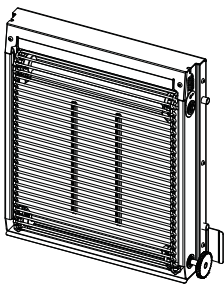
10 Reinstall the conveyor. Using the handle on back to lift the conveyor, line up the side posts of the conveyor with their notches on the CTS. Move the conveyor into the CTS and gently release.

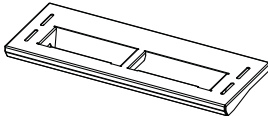
Service Kits

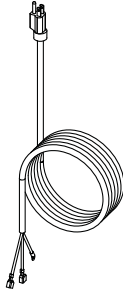
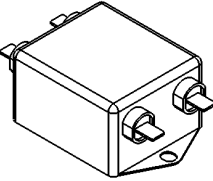
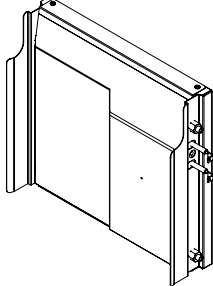
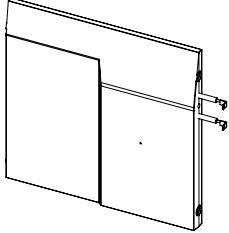
| | | | |
|---|---|---|--|
| <p>1</p>  <p>299-030S Control Board Kit</p> | <p>2</p>  <p>299-029S Display Board Kit</p> | <p>3</p>  <p>299-017S Overlay Kit</p> | <p>4</p>  <p>527-468S Temperature Probe Kit</p> |
| <p>5</p>  <p>299-072S Triac Kit</p> | <p>6</p>  <p>299-060S Motor Kit</p> | <p>7</p>  <p>299-046S Gears Kit</p> | <p>8</p>  <p>299-070S Bearing Kit</p> |
| <p>9</p>  <p>299-020S Wire Conveyor Assy. Kit 299-021S Track Conveyor Assy. Kit</p> | <p>10</p>  <p>299-041S Knobs Kit</p> | <p>11</p>  <p>299-058S Infeed Kit</p> | <p>12</p>  <p>78-233S Power Switch Kit</p> |
| <p>13</p>  <p>72-280S 115V Powercord, US 72-323S 220V Powercord, CE</p> | <p>14</p>  <p>88-828S EMI Filter Kit *Used on CE units only</p> | <p>15</p>  <p>299-010S Platen Assy, 115V 299-022S Platen Assy, 240V</p> | <p>16</p>  <p>299-011S Platen, 115V 299-012S Platen, 240V</p> |

Service Kits

Consumables & Kits Continued

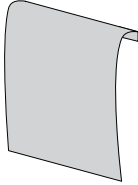
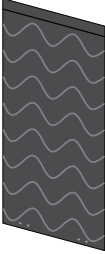
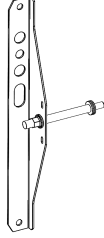
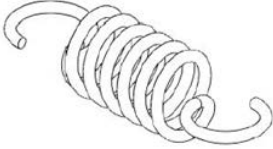
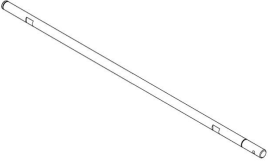
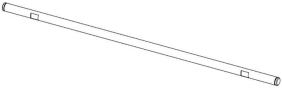
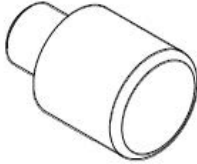
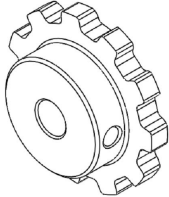
| | | | |
|---|--|---|--|
|  <p>299-061S Release Sheet</p> |  <p>299-063S Silicon Conveyor Belt</p> |  <p>299-036S Crush Adjustment Left or Right side</p> |  <p>299-028S Conveyor Tensioner Spring</p> |
|  <p>299-025S Bottom Shaft, Driven</p> |  <p>299-026S Top Shaft, Drive</p> |  <p>197-467S Conveyor Locating Pin (4 pcs)</p> |  <p>299-074S Sprocket, Metal, 11 Tooth</p> |
| | | | |
| | | | |

Accessories

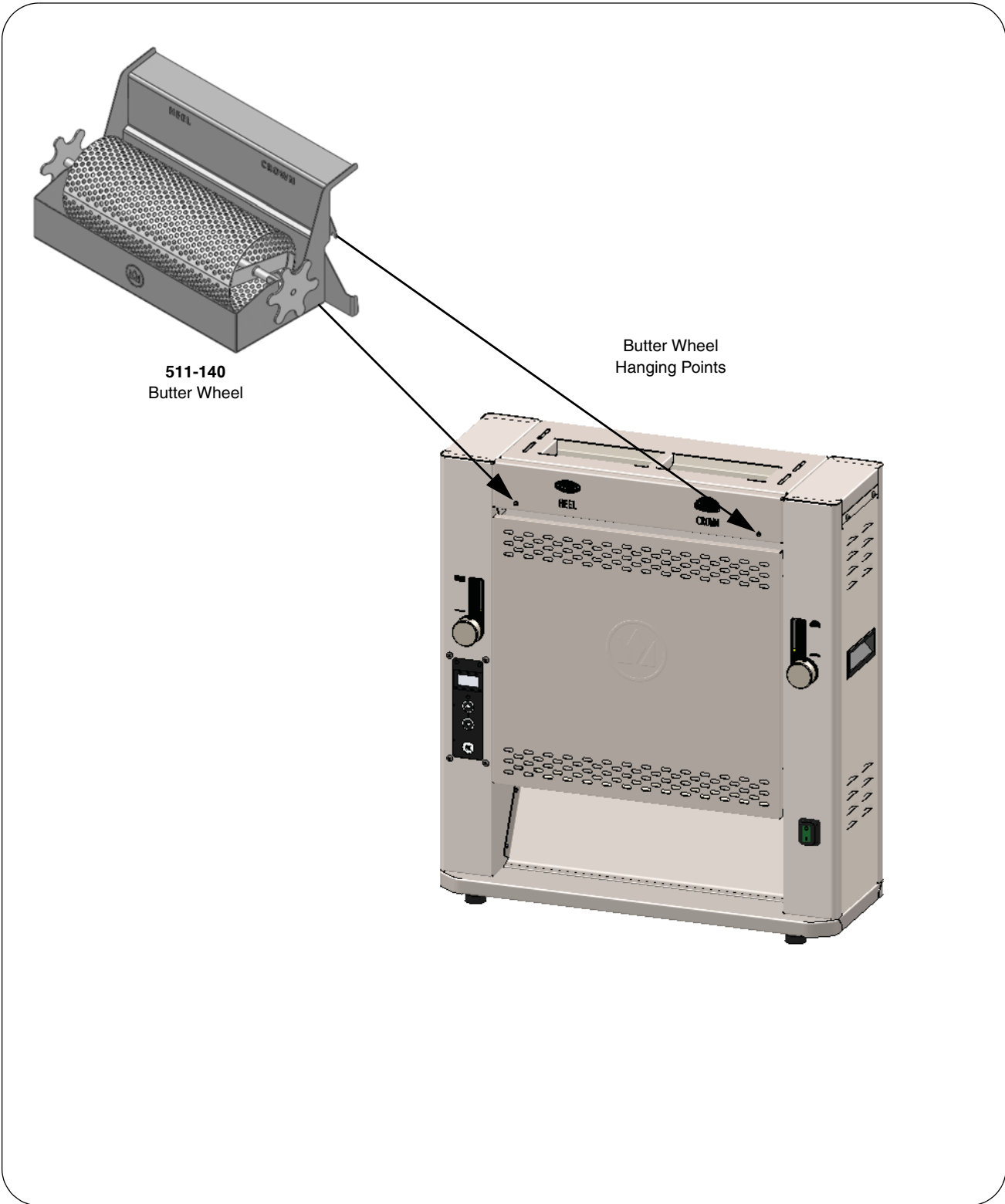

Wiring Diagram

