

Operation Manual

Heater Panels and Controllers

Product Identification

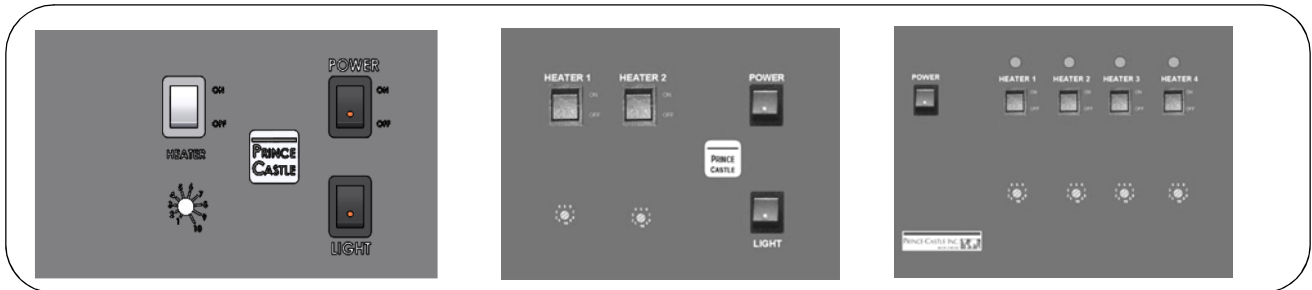
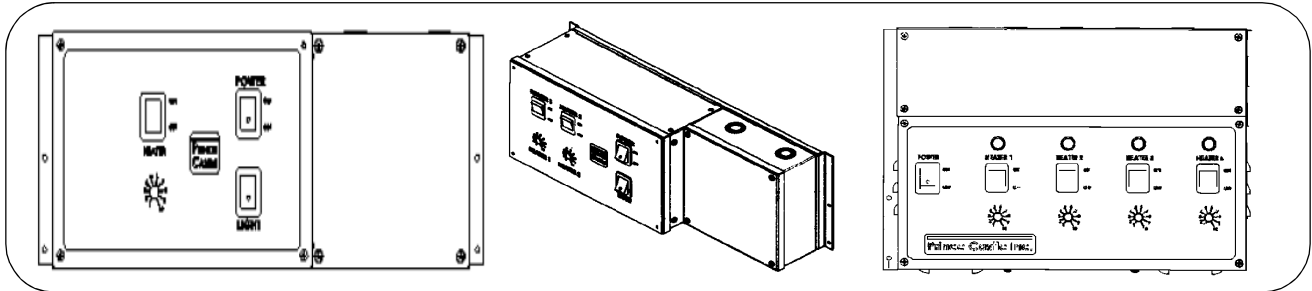

HPC-1SNCA

HPC-2A/2AF

HPC-4

LIMITED WARRANTY

This product is warranted to be free from defects in material and/or workmanship for a period of 1 year from date of original installation, not to exceed 18 months from the date of manufacture.

Any component which proves to be faulty in material and/or workmanship will be replaced or repaired (at the option of Prince Castle, Inc.) without cost to the customer for parts and labor. This warranty covers on-location service (i.e. trip charges and/or mileage). Travel mileage is limited to 100 miles (200 Kilometers) round trip (one trip warranty) from an authorized service agency or its sub-service agency.

This warranty is subject to the following exceptions/conditions:

- Use of any non-genuine Prince Castle parts voids this warranty.
- All labor to be performed during regular work hours. Overtime premium (the incremental amount) will be charged to the customer.
- Damage caused by carelessness, neglect and/or abuse (e.g., dropping, tampering or altering parts, equipment damaged in shipment, by fire, flood or an act of God) is not covered under this warranty.
- All problems due to operation at voltages other than that specified on equipment nameplates are not covered by this warranty. Conversion to correct voltage is the customer's responsibility.
- This equipment must be serviced by Prince Castle Authorized Service Agency or a Prince Castle Service Technician during the warranty period.

TABLE OF CONTENTS

Product Identification	1
Specifications	2
Controller Installation	2
Heater Installation	3
Start Up	4
Setting Recommendations	4
Cleaning	5
Exploded View and Parts List — Controllers	6, 7, 8
Exploded View and Parts List — Heater Panels	9
Exploded View and Parts List — Light Fixture	10
Wiring Diagrams	11-14

PRINCE CASTLE INC. 
WORLDWIDE

355 East Kehoe Blvd. • Carol Stream, IL 60188 USA
Telephone: 630-462-8800 • Toll Free: 1-800-PCASTLE
Fax: 630-462-1460 • www.princecastle.com

Specifications

Model	Volts	Max. Watts	Hertz
HPC-1SNCA	208/240	3600	50/60
HPC-2A/2AF	208/240	3900	50/60
HPC-4	208/240	7800	50/60

NOTE: Wattage depends on the size of the Heater Panels.

Controller Installation

- 1 Remove unit from carton and inspect for signs of damage. If there is damage to the unit:
 - notify carrier within 24 hours of delivery.
 - save carton and packaging material for inspection purposes.
 - contact your local dealer, or if purchased directly, the Prince Castle Sales Department at 800-772-7853 or 630-462-8800 to arrange for a replacement unit.

- 2 Attach controller to the counter.

- 3 Attach the input power leads to the Controller Wiring Box. Connect the power leads to the terminals as shown in the Input Power Terminal Block wiring label.

NOTE: The required voltage is 208 to 240 V, Single Phase. All wiring to be in rigid or flexible conduit.

A. The wire connections are:

- L1 to Red
- L2 to Black
- Neutral to White
- Earth Ground to Green/Yellow

B. The panel will draw a maximum of 17 amps or 4100 Watts at 208 to 240 volts.

NOTE: The HPC-2 should be wired to a dedicated 25-amp circuit.
The HPC-4 should be wired to a dedicated 40-amp circuit.

All wiring to and from the controller must be in either flexible or rigid metal conduit.

- 4 Connect the Green with yellow stripe ground wire to one of the terminals shown in either of the Heater Terminal Block wiring diagrams.

- 5 If the heater panel has a fluorescent light, connect the optional red and orange leads for the fluorescent light to the terminals as shown on the Light Terminal Block Wiring Diagram.

If an optional fluorescent light kit (FL-26) is to be installed, follow the installation instructions in the light fixture manual.

- 6 Turn the power switches on.

- 7 Turn the heater and light switches on.

- 8 Allow 45 minutes for the unit to warm up.

Heater Installation

1 The brackets may either be mounted along the length or width of the heater panel. For heater panels with lights, please allow 1/4" of space above the light housing.

3 Attach the mounting bracket to the mounting studs.

2 Remove mounting brackets from the heater panel and save the screws.

4 Position the heater panel to the mounting brackets and secure the panel in place using the screws from step 2.

1. Measure the mounting clips or remove them and use them as a template when mounting the panel.

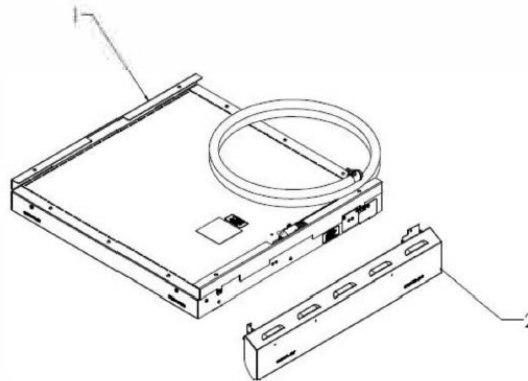

2. Optional light fixture (LF-26) sold separately. See light fixture installation instructions for more details.

CAUTION

To reduce the risk of fire, this appliance should be installed in non-combustible surroundings only. There should be no combustible material within 18 inches of the sides, front, or rear of the appliance or within 40 inches above the appliance. The appliance is to be mounted to non-combustible surfaces and radiate to non-combustible floors. These surfaces and floors should extend no less than 12 inches beyond the appliance on all sides.

Start Up

NOTE: During the first few hours of operation, the heaters may produce a faint odor. This is normal and the odor will disappear after the first few hours of use.

The heater panel and control are tested and calibrated at the factory before shipment. However, temperature and climate changes during shipment can allow the insulation in the heater panel to absorb moisture. During the first few hours the unit is in use, this moisture is driven from the insulation while the insulation dries. The drying insulation often gives off a faint odor which will disappear after a few hours.

Setting Recommendations

Due to different airflow patterns found in each store, the actual heater settings for each store will be different. Air flow patterns are affected by drive-through windows, open front and rear doors, air conditioning and make up air vents. All of these sources of air will draw heat away from the food. Below are some recommended settings that may be used as a starting point before making final adjustments for each restaurant.

NOTE: A higher temperature setting will yield hotter food temperatures; however, the higher temperature will result in more moisture being driven from the food. At the end of the maximum hold time, an ideal temperature setting will result in food that is at or above the minimum serving temperature and still meets all quality requirements.

Distance versus Temperature Setting

Style 1

If the maximum distance between the heating surface and the surface on which the food is placed is 20 inches, the recommended adjustment range is from 7 to 10.

Distance versus Temperature Setting

Style 2

If the maximum distance between the heating surface and the surface on which the food is placed is 15 inches, the recommended adjustment range is from 4 to 7.

Temperature Adjustment

Each heater panel has a separate On/Off switch and a separate temperature adjustment. To adjust the temperature, put a blade screwdriver in the temperature adjustment pot. Turn the pot counterclockwise to decrease the temperature and clockwise to increase the temperature. Stop turning the pot when the blade is pointing at the desired value.

Cleaning

 **CAUTION**

This unit is NOT water tight. Do NOT clean with Water Jet/Jet Spray. Before cleaning, make sure the power switches are in the OFF position.

1 Turn the power switch to the OFF position.

3 Wipe down surface with a damp cloth. Do not use a green Scotch Bright pad, or unapproved cleaner.

2 Allow the bin to cool down (approximately 35 minutes).

4 Turn power on after all surfaces are dry.

Exploded View and Parts List – Controllers

HPC-1SNCA

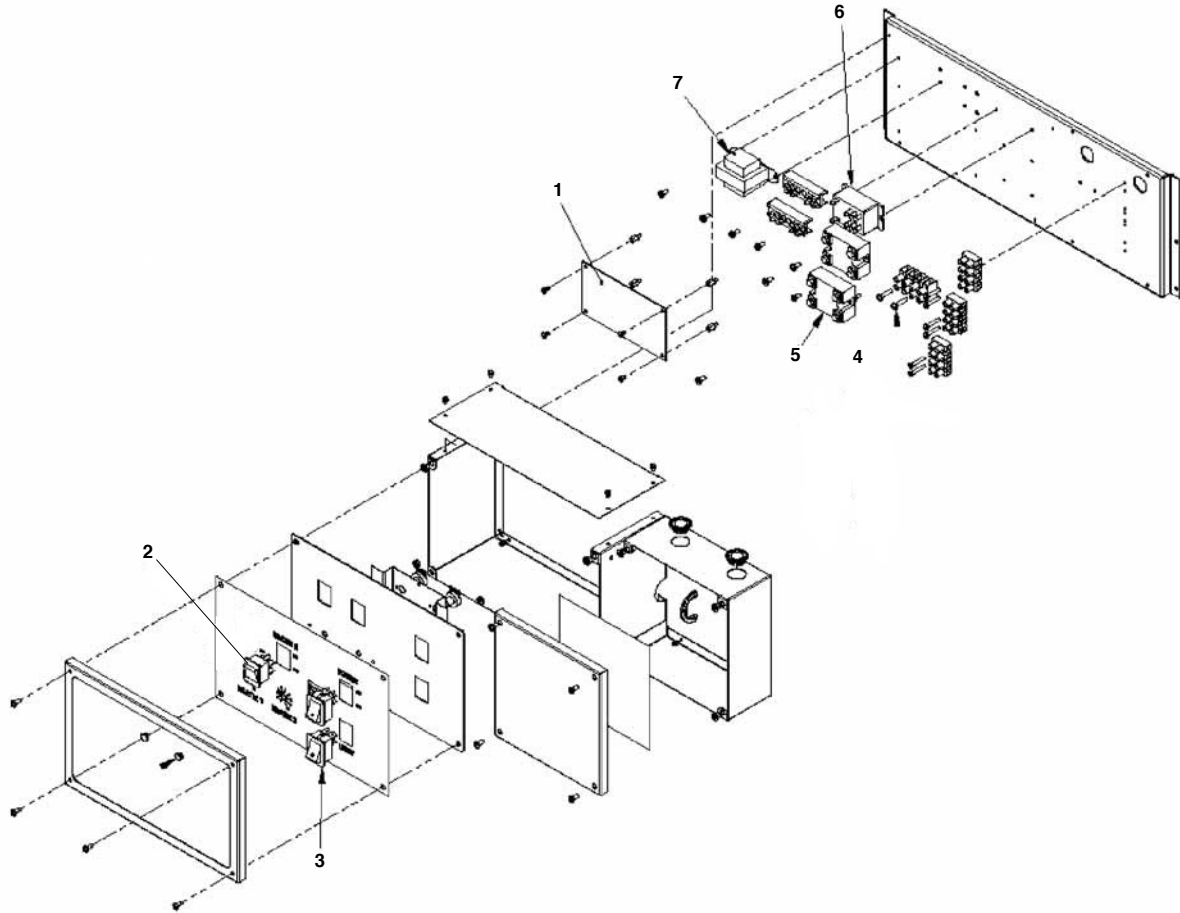

Ref.	No.	Description
1	428-440S	Main PCB
2	78-218S	Rocker Switch
3	78-184S	Lighted Rocker Switch
4	65-058S	HPC-2AF Relay Kit
5	65-048-07S	Relay Kit, HPC-2A
	65-048-10S	Relay Kit, HPC-2AF
6	537-388S	Transformer Assy, HPC-2A
	528-443S	Transformer Assy, HPC-2AF

Exploded View and Parts List – Controllers

HPC-2A/2AF

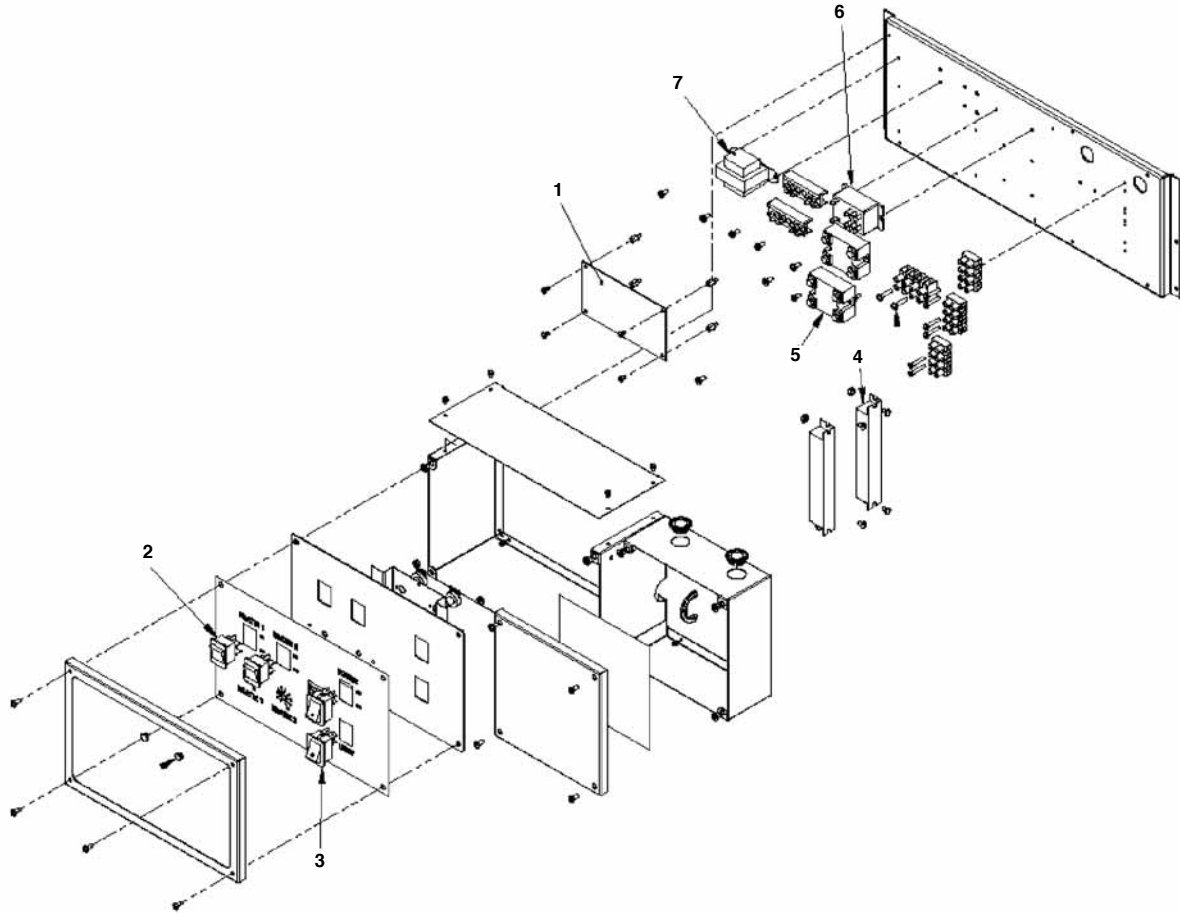

Ref. No.	Description
1	428-440S Main PCB
2	78-218S Rocker Switch
3	78-184S Lighted Rocker Switch
4	528-359S Ballast Kit, HPC-2A
	528-736S Ballast Kit, HPC-2AF
5	65-058S Relay Kit
6	65-048-07S Relay Kit, HPC-2A
	65-048-10S Relay Kit, HPC-2AF
7	537-388S Transformer Assy, HPC-2A
	528-443S Transformer Assy, HPC-2AF

Exploded View and Parts List — Controllers

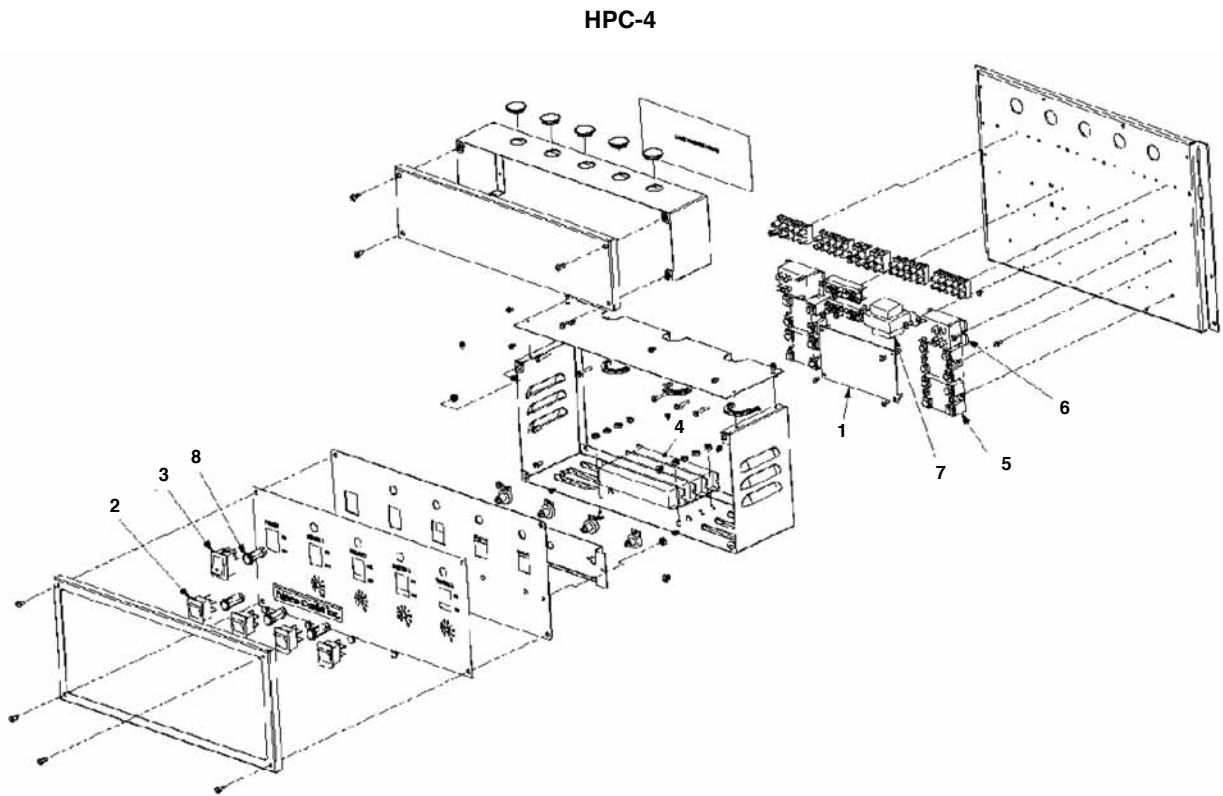

Ref.	No.	Description
1	428-440S	Main PCB
2	78-218S	Rocker Switch
3	78-184S	Lighted Rocker Switch
4	528-442S	Ballast Kit
5	65-058S	Relay Kit
6	65-048-07S	Relay Kit
7	528-443S	Transformer Kit
8	71-135-1S	Amber Pilot Light Kit

Exploded View and Parts List — Heater Panels

HP19-26

NOTE: Heaters and glass are not field replaceable.

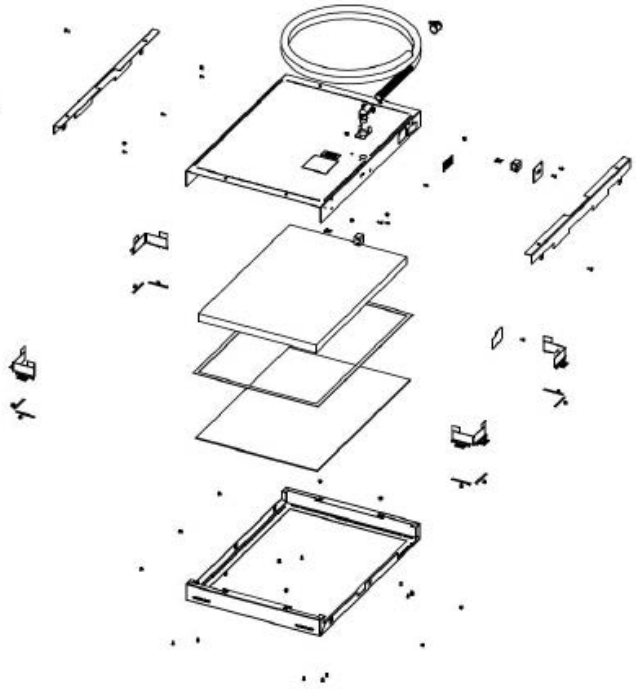

HP26-26

NOTE: Heaters and glass are not field replaceable.

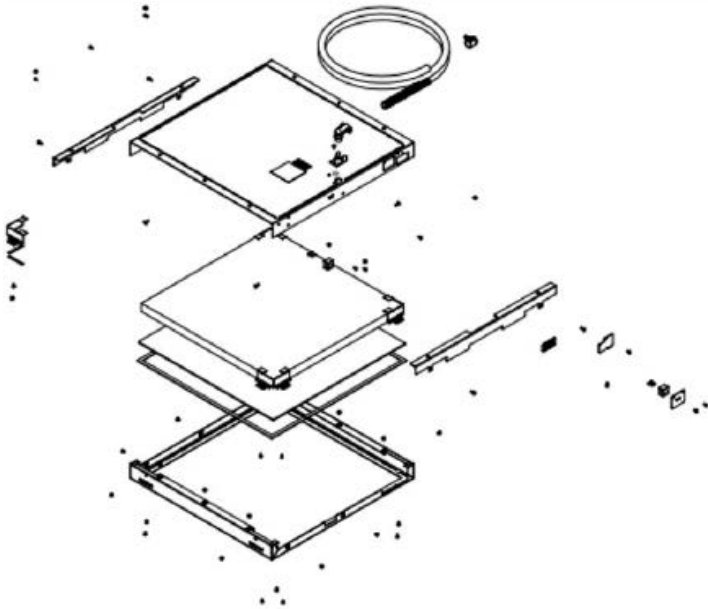

Exploded View and Parts List — Light Fixture

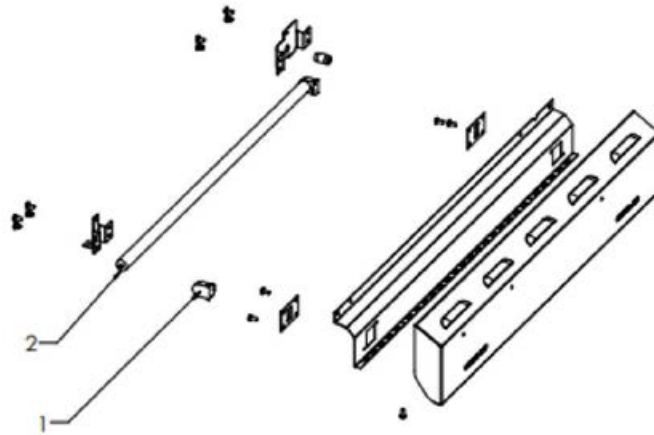

Ref.	No.	Description
1	88-682S	Lampholder Kit
2	88-793-01S	Fluorescent Lamp Kit

NOTE: Light fixtures are sold separately.

Wiring Diagrams

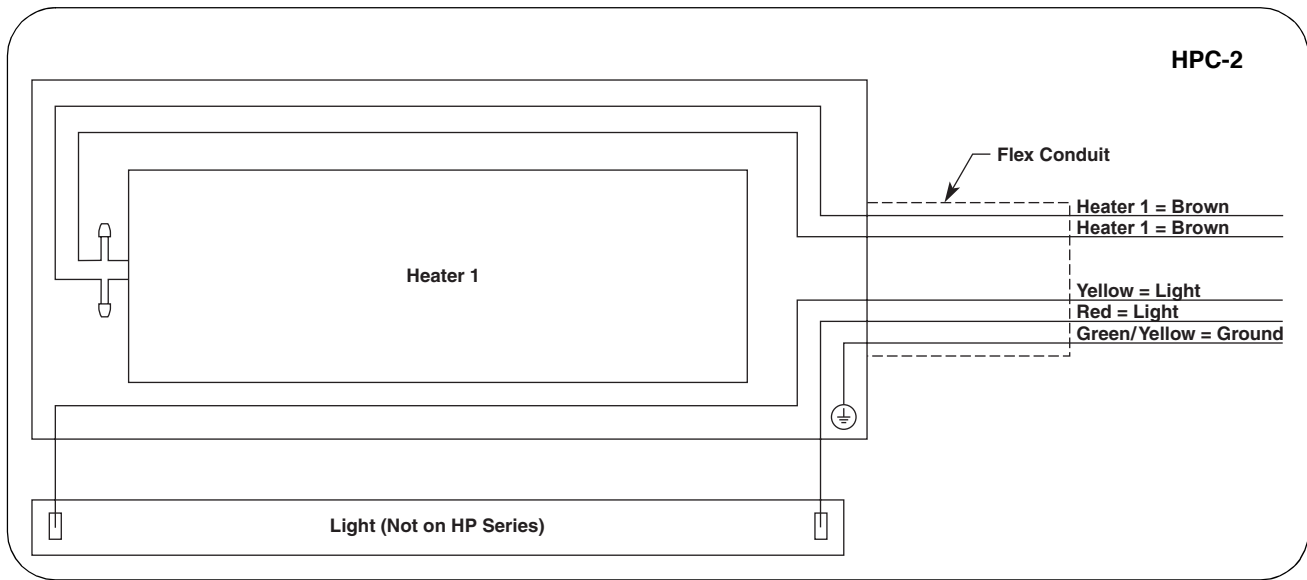

Wiring Diagrams (Continued)

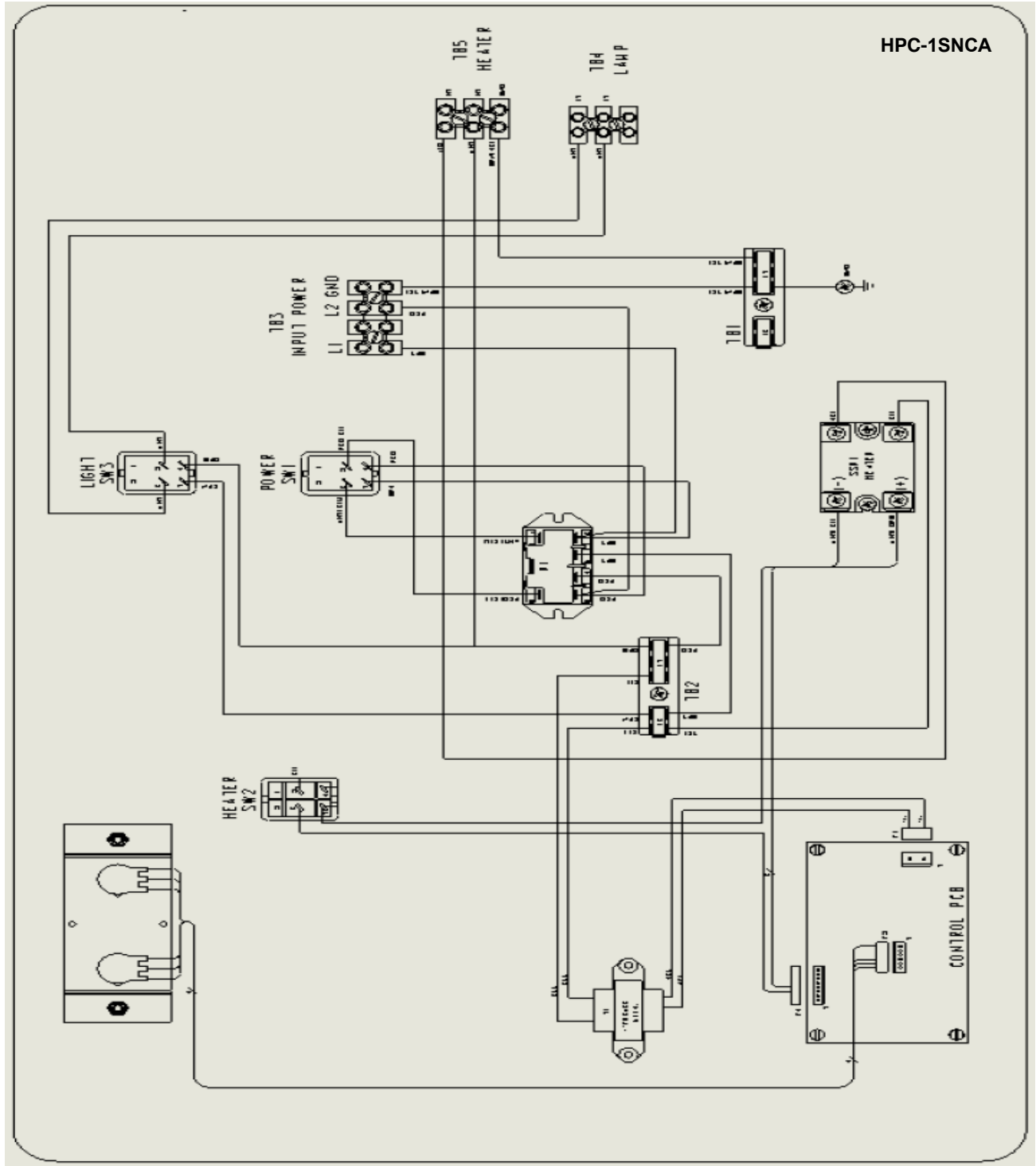

Wiring Diagrams (Continued)

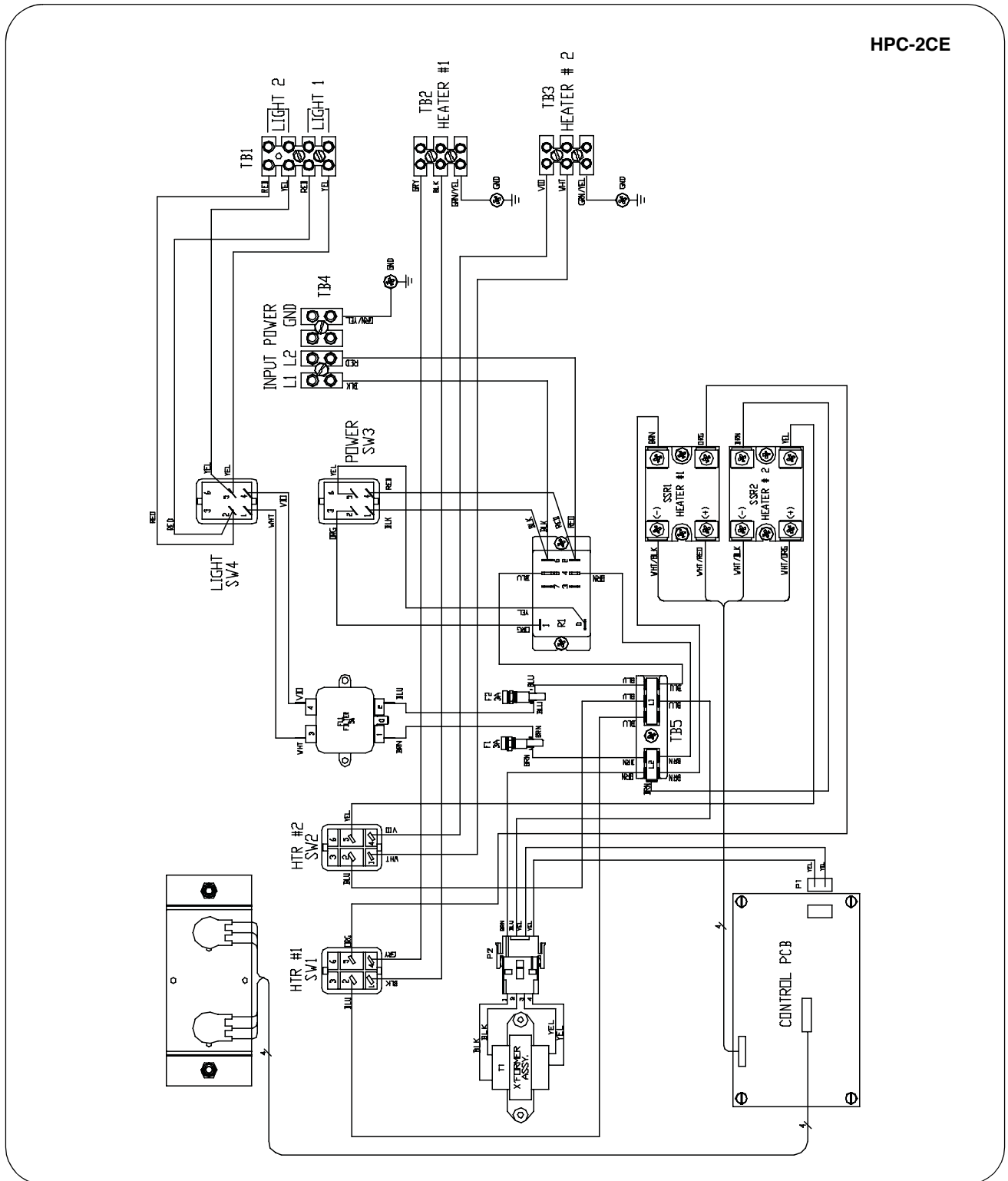

Wiring Diagrams (Continued)

HPC-4CE

