



INSTALLATION AND OPERATION INSTRUCTIONS

4400QC SERIES POWER PAKS



		MODELS			
Compressor Size		1/3 HP	1/2 HP	3/4 HP	1-1/2 HP
# of Circulating Pumps	1	4404QC	4410QC	4414QC	4420QC
	2		4410QC-2	4414QC-2	4420QC-2
	3				4420QC-3



IMPORTANT INFORMATION

To register your product, visit our web site at perlick.com. Click on **Commercial**, then **Service**. You will see the link to **Warranty Registration Form**. You must complete and submit this form or the installation date will revert back to the ship date.

Permanently mount the enclosed Warning/Safety Instruction label in a visible location near the CO2 regulator.

This manual has been prepared to assist you in the installation of your 4400QC Series Power Pak and to acquaint you with its operation and maintenance. We dedicate considerable time to ensure that our products provide the highest level of customer satisfaction. If service is required, your dealer can provide you with a list of qualified service agents. For your own protection, never return merchandise for credit without our approval.

We thank you for selecting a Quick Chill product and assure you of our continuing interest in your satisfaction.

Table of Contents

Sizes & Specifications	2-3
General Information.....	3
Installation	3-4
Connecting Power Pak to Trunk Housing.....	4-5
Power Pak Start-Up.....	5-6
LEDS	6-7
Preventative Maintenance	6-7
Replacement Parts	7
Wiring Diagrams	8

Form No. Z0507QC
Rev. 06.01.23



8300 West Good Hope Road • Milwaukee, WI 53223 • Phone 414.353.7060 • Fax 414.353.7069
Toll Free 800.558.5592 • E-Mail perlick@perlick.com • www.perlick.com



4400QC SERIES POWER PAKS - AIR COOLED

- INSTALLATION AND OPERATING INSTRUCTIONS

MODEL NOS.	4404QC	4410QC	4410QC-2	4414QC	4414QC-2	4420QC	4420QC-2	4420QC-3	
DIMENSIONS: EXTERIOR (mm)*	Length "A"	24-1/4" (616)				26-3/4" (680)			
	Width "B"	17-1/4" (439)				20-1/4" (515)			
	Height "C"	25-1/2" (648)				31" (788)			
	*A minimum of six inches of clearance should be allowed around the entire unit for proper performance. Additional Clearance should be considered for above the unit and in front of the unit for serviceability.								
ELECTRICAL	Voltage	120V				115-208/230V **			
	Frequency	60 Hz							
	Phase	1 Ø							
	RLA (Rated Load Amps)	14.4	15.7	21.8	20.6	26.2	21.9	24.7	27.5
	MCA (Min. Circuit Ampacity)	16.4	18.0	24.1	24.0	29.6	26.6	29.2	32.0
	MOCP (Max. Over-Current Protection)	20	25	30	35	40	40	45	50
COMPRESSOR (Horse Power)	1/3	1/2		3/4		1-1/2			
EVAPORATOR RATING @ 20°F (BTUH)	2550	3800		6000		12000			
HEAT of REJECTION MAX (BTUH)	4080	6080		9600		19200			
REFRIGERATION	Constant Pressure Expansion Valve, Condensing Unit with Service Valves								
REFRIGERANT (TYPE)	R-134a								
REFRIGERANT CHARGE	14.0 oz/397g	12.0 oz/340g		14.0 oz/397g		16.0 oz/454g			
SHIPPING WEIGHT LBS (kg)	140 (64)	138 (63)	150 (69)	167 (76)	180 (82)	217 (99)	230 (105)	245 (112)	
CABINET	Black Vinyl Clad Galvanized Steel								
CIRCULATING PUMP	70 GPH / 80 PSIG (MAX)								
RESERVOIR CAPACITY	1.75 Gallons								
GLYCOL CONCENTRATION	30%								
OPTIONAL ACCESSORIES (Sold Separately)	<ul style="list-style-type: none"> • C22296A-20 - Power Cord Kit for 4404QC & 4410QC Single Pump Units Only (NEMA 5-20P) • 57782 - Adjustable Legs (Set of 4) • 61468 - Overflow Bottle Kit • 63299-1 - Food Grade Glycol Pre-Mix (1 gallon) • 61790A2 - Dual Tier Rack • 61790A3 - Triple Tier Rack • C21499SS - Stainless Steel Table Stand • 44085S - Wall Bracket for 4404QC & 4410QC Only 								

**4-WIRE AC POWER SOURCE REQUIRED
AC - 115-208/240V, 60Hz, Split Single Phase
(Ground, Neutral, Hot-Power, Hot-Power)

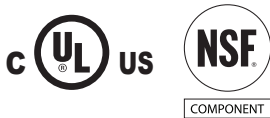

⚠ WARNING: California Prop 65 Notice
These products may expose you to chemicals including Chromium, which are known to the state of California to cause cancer and birth defects or other reproductive harm. For more information on whether a product in this list contains these chemicals, please refer to the specific product page at perlick.com. Or to find out more about Prop 65, go to P65Warnings.ca.gov.

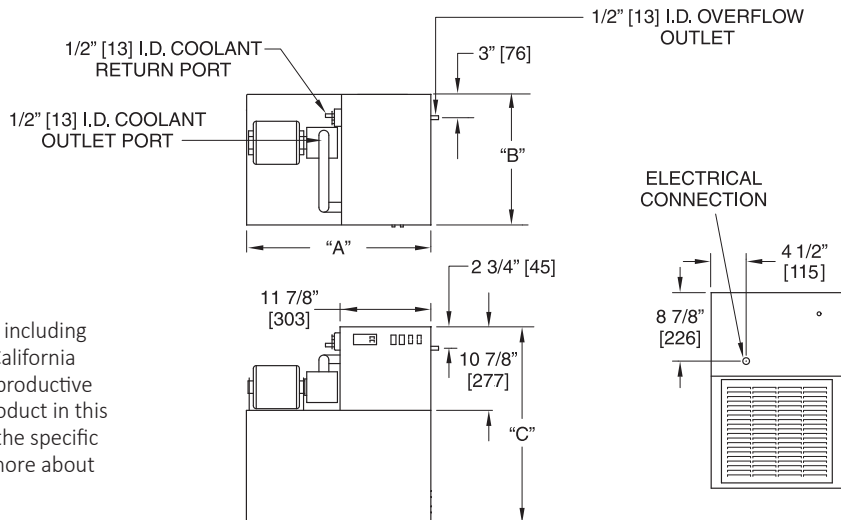

Perlick is committed to continuous improvement. Therefore, we reserve the right to change specifications without prior notice

4400QC SERIES POWER PAKS - AIR COOLED - GENERAL INFORMATION



Accessories

Power Cord Kit

C22296A-20 – 12/3 Cord, 20A, Nema Plug 5-20P,
Dedicated Circuit Models – See electrical specifications.

NOTE: Use only with 4404QC and 4410QC Single Pump units only.

Power Pak Racks

61790A2 Dual Tier Rack, 61790A3 Triple Tier Rack –
All Models

Power Pak Wall Mounting Brackets

4408SS – For Models 4404QC and 4410QC only

Coolant Solution – **63299-1**

Food Grade Glycol Pre-Mix (1 Gallon)

Coolant Connector Kit

C23015 – All Models

Leg Set – All Models

57782 – Set of four, 5 ³/₄"-7 ¹/₂" adjustable legs

PRODUCT DESCRIPTION

Power Paks have always been an integral part of a Beer System. The 4400QC Series Power Pak product line has been expanded to satisfy longer beer runs. A Power Pak circulates coolant solution (food grade propylene glycol with distilled water) from the walk-in cooler to the dispensing station(s) and back, maintaining the desired dispensing temperature at the faucet. The 4400QC Series Power Paks incorporate a 1/3 hp ball bearing, maintenance free motor with a 70 gallon per hour 80 psig positive displacement pump for optimum performance. The 4400QC series Power Pak product line employs a direct expansion form of refrigeration increasing the units' efficiency as well as making the units more compact. These units also employ an electronic temperature control with digital readout. This state of the art control, controls the performance of the unit as well as giving the user a visual indication of how the unit is working as well as early indication if something may be going wrong through the use of internal alarms.

INSTALLATION – 4400QC Series Power Paks

IMPORTANT SAFETY WARNINGS!

- Follow all National and Regional Codes.
- Read Installation and Operating Instructions carefully before attempting to install, operate or maintain the product.
- Protect yourself and others by observing all safety information.
- Electrical hazards exist and can cause injuries if not serviced by properly trained personnel.
- Failure to comply with instructions could result in personal injury and/or property damage!
- Retain instructions for future reference.
- Never operate the circulating pump without coolant in the reservoir.

NOTE: Air-cooled Power Paks must be installed in areas with adequate ventilation to maintain ambient temperatures of less than 105°F to achieve optimum performance and satisfy warranty requirements.

INSTALLING THE POWER PAK

Prior to installing a 4400QC Series Power Pak, it is imperative that the method of connecting it to the electrical service has been determined. Ensure that the electrical service to power the Power Pak will handle the load requirements. Perlick has a Power Cord specifically designed for a Power Pak, which has a RLA of 16 amps or less, and a MCA of 20 amps or less. All units with RLA greater than 16 amps and a MCA of greater than 20 amps should have the Power Pak hard-wired to electrical service.

PRODUCT/SERVICE/WARRANTY INFORMATION

To Obtain Product Information

- Contact your selling dealer.
- Inquire on the web at perlick.com.
- Call 800-558-5592 for factory assistance for information, planning, installation or product information.
- Write **Perlick Corporation, Customer Service Department**, 8300 W. Good Hope Road, Milwaukee, Wisconsin 53223.
- E-mail us at warranty@perlick.com.

To Obtain Product Service, Replacement Parts or Accessories:

Use only genuine Perlick replacement parts and accessories. Genuine Perlick parts and accessories are designed to work correctly with

Perlick products and offer superior service life. The use of non-Perlick parts can damage the unit and may void the warranty.

Check the model and serial number of the unit located on the label attached to the inside top of the cabinet.

Call a Perlick Factory Authorized service center. For the location of the nearest Service Center, contact your dealer, or inquire via the web at perlick.com, or write to:

Perlick Corporation, Customer Service Department,
8300 W. Good Hope Road, Milwaukee, Wisconsin 53223,
call 800-558-5592, or e-mail us at:
warranty@perlick.com.



4400QC SERIES POWER PAKS - AIR COOLED - INSTALLATION

ALL MODELS

- Determine the ideal placement of the Power Pak. Locate the connection point to the truck housing and place the Power Pak as close to this point as possible. **NOTE: If the Power Pak is to be located on top of the walk-in cooler, it is imperative that proper ventilation is provided to prevent system failure due to overheating. Inadequate ventilation will void warranty.**
- Place the Power Pak and Ensure that it is level to provide proper overflow protection. **REMINDER: Allow a minimum of six inches of clearance on the louvered ends of the cabinet for proper airflow. Allow accessibility room on the top of the cabinet for serviceability.**
- Remove the top panels (2).
- Ensure Power Switches for Condensing Unit and Pump(s) are in the OFF position. Make the electrical connections per their illustrations. NOTE: Electrical circuit should be a dedicated circuit for use only with the Power Pak. The circuit should be sized in accordance with the electrical requirements of each unit as well as in compliance with all National and Local Codes.
- Plumb overflow port to a suitable reservoir/drain.

CONNECTING POWER PAK TO TRUNK HOUSING

4400QC Series Power Paks require rigid fittings with a minimum pressure rating of 150 psig. Use Coolant Connector Kit [C23015](#) to connect Power Pak to Trunk Housing.

- Inspect pump outlet port for debris. Insert barbed fitting into pump outlet port.
- Inspect Glycol Return Manifold inlet for debris. Insert barbed fitting into return manifold inlet port.
- Cut supplied coolant tubing, to required length to reach from Power Pak to Trunk Housing connection point.
- Cut tubular insulation sleeve, in half and install over previously cut coolant tubing.
- Take oetiker clamps, and install over coolant tubing ends.
- Push coolant lines, one each over pump outlet

- barbed fitting and return manifold barbed fitting.
- Position oetikers over barbed fitting and clamp securely.
- Slide tubular insulation sleeves tightly against connection points. Use insulation tape as necessary to ensure an air tight seal to prevent excessive heat gain or condensation problems.
- Drill a 3 1/2 " diameter hole in walk-in cooler to accommodate coolant lines.
- Install insulating donuts over hole (both inside and outside of cooler walls).
- Slide large insulation sleeve, over remaining coolant tubing exposed to warm air conditions including inside walk-in cooler from Power Pak to Trunk Housing connection point. Seal and tape all seams to prevent excessive heat gain or condensation problems.
- Slide coolant lines through 3 1/2 " donut hole previously cut in walk-in cooler wall.
- Position Trunk Housing coolant lines and Coolant Connector kit lines in horizontal position, to alleviate condensation runoff into Trunk Housing.
- Cut Trunk Housing coolant lines with tubing cutter to ensure clean burr free ends.
- Take oetiker clamps and install over coolant connector kit tubing ends.
- Slide coolant connector kit tubing over the trunk housing coolant lines and secure using above oetikers.
- Complete the insulation process by ensuring that all coolant lines are well insulated including all seams to prevent excessive condensation and heat gain.
- Seal donut hole to ensure an air tight seal to prevent walk-in cooler problems as well as condensation.

4400QC SERIES POWER PAKS - AIR COOLED - CONNECTION TO TRUNK HOUSING



POWER PAK START-UP 4400QC SERIES POWER PAKS

Use only Quick Chill Approved Coolant Solution, #63299-1, all other solutions and mixtures will void the warranty. The Coolant Solution has been pre-mixed for Optimum performance and wear protection. The Power Pak reservoir holds approximately 1.75 gallons of solution. It takes approximately 1 gallon of Coolant Solution to fill every 60 feet of Trunk Housing.

- Never operate the circulating pump without coolant in the reservoir.
- Fill Power Pak reservoir with Quick Chill Coolant Solution.
- Turn condensing unit switch and pump switch to the ON position. Coolant solution level will begin to drop in reservoir.
- Continue adding Quick Chill Coolant Solution until no air bubbles are apparent from the Coolant return line.

NOTE: Never allow for the Coolant level in the reservoir to drop below the heat exchanger tube inlet. Allowing the level to drop below the inlet will allow air bubbles into the lines.

- Fill Power Pak reservoir until both the return line fitting port and the overflow tube port are submersed under Coolant Solution. Watch return line fitting port for additional air bubbles as this may signify additional Coolant Solution may need to be added.
- Thoroughly check all field connection points for leaks.
- Monitor Power Pak Temperature read-out to ensure Power Pak is working properly. Depending on length of trunk housing run and surrounding ambient conditions, these factors will determine how long it takes for the Power Pak to cut-out on the temperature control.

INSTRUCTION DRAWING FOR 4400 SERIES POWER PAK COOLANT CONNECTOR KIT INSTALLATION INSTRUCTIONS

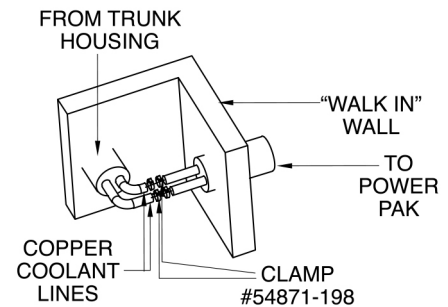
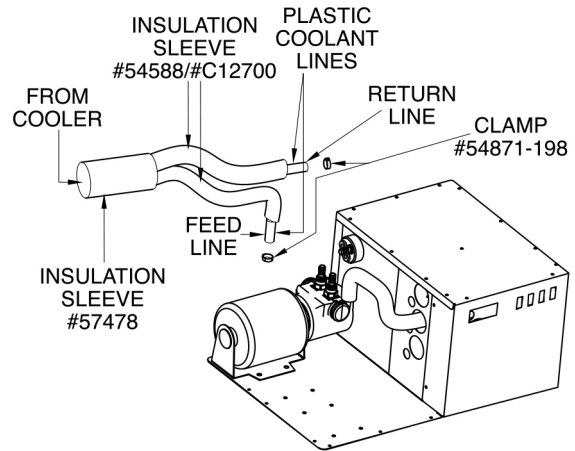

INSIDE "WALK IN" COOLER

DIGITAL TEMPERATURE CONTROLLER

The 4400QC Series Power Pak comes equipped with a Factory Programmed Electronic Thermostat with Display. The Thermostat has numerous factory settings, which should never be adjusted or tampered with to ensure proper operation of the Power Pak. The Thermostat has been factory programmed to cut-out at 30°F with a hysteresis/differential of 4°F.

To Adjust the Temperature Set Point (Figure 1):

1. Press the **set** button. The label "SET" will be displayed.
2. Press the **set** button a second time. The set point will be displayed.
3. To change the Set point value, press the **↑** or **↓** keys within 15 seconds.
4. Press **set** to confirm the new setpoint value.
5. After 10 seconds the display will return to indicating the cabinet temperature.



Figure 1: Digital Temperature Controller

On/Off:

Press the ON/OFF button to turn the unit on or off.

Key Combinations:

- ↑ + ↓** Press the UP and DOWN arrow buttons to lock and unlock the keyboard.
- SET + ↓** Press the SET and DOWN arrow buttons simultaneously to enter programming mode.
- SET + ↑** Press the SET and UP arrow buttons simultaneously to return to room temperature display.

LED Functions

The following table describes LED functions

LED	Mode	Function
	ON	Compressor is on
	Flashing	Delay, protection or Blocked start-up
	ON	Defrost is on
	Flashing	Manual or D.I. activation
	ON	Alarm is on
	Flashing	Alarm acknowledged
	ON	Evaporator is on

Alarm

Meaning

Action

E1 Probe failure Numerous - see note 1

NOTE 1: Faulty probe, loose connection, broken wire (Power Pak will continue to operate with a faulty probe). The controller has been factory programmed to continue operation with the compressor cycling on and off in 5 minute intervals.

4400QC SERIES POWER PAKS - AIR COOLED - LEDS & PREVENTATIVE MAINTENANCE



REPLACEMENT PARTS

COMPONENT/MODEL	4404QC	4410QC	4414QC	4420QC
Condensing Unit	668HE5108AA (1012125)	559HG5110HA (C22667)	M7GH-H083-CFA-121 (1022593)	FPAK-015Z-CFV-140 (C22668)
Compressor	268HE71 (1015091)	269HG9290AF (C22999CMP05)	RRT10K1E-PFA-901	ZS19KAE-PFV-818
Cond Fan Motor	1450076 (C22999FMTR01)	1450095 (C22999FMTR02)	950-0367-00	950-0265-00
Fan Blade	2455003 (C22999FBLD01)	2455003 (C22999FBLD01)		083-0033-01
Start Components	US-PBNEU6210Z1 (1015092)	US-PBNEK6214Z1 (C22999STCP07)		
Relay-Potential Kit			940-0046-26	940-0001-79
Start Capacitor Kit			914-0036-16	914-0036-03
Run Capacitor Kit			914-0037-12	914-0017-36
Pump Motor	63292	63292	63293	63293
Heat Exchanger	63300B	63300B	63301B	63302B
Gasket, Heat Exchanger	61758A	61758A	61758A	61758A
Grille	64197-3B	64197-3B	64197-3B	64285-1B
Front Panel	64407-1B	64407-1B	64407-1B	64286-1B
Contactors				63359
Relay, Pump				63358
Access Panel				1018561-1B

COMMON COMPONENTS

COMPONENT	ALL MODELS
Pump	63562
V-Clamp	63291-2
Constant Pressure Exp Valve	63826
Switch	63303
Drier	63297

Coolant Solution	63299-1
Temperature Control Kit	1008503
Temp Control	1007439
Probe	1050282
Compression Fitting	1008057
Wire Harness	61834-2

PREVENTATIVE MAINTENANCE

Clean Condenser

Condenser, located behind the grille, should be cleaned as required of all dirt and debris, at minimum every 3 months, more frequently if required. Use soft bristle brush and/or vacuum to remove dust and debris, avoid damaging the condenser fins.

Coolant Solution

Periodically check coolant solution level and concentration. Added or replace the coolant solution with Perlick Coolant Solution if required.



4400QC SERIES POWER PAKS - AIR COOLED - WIRING DIAGRAMS

Wiring Diagram For 4404QC, 4410QC, 4414QC 115V Power Paks

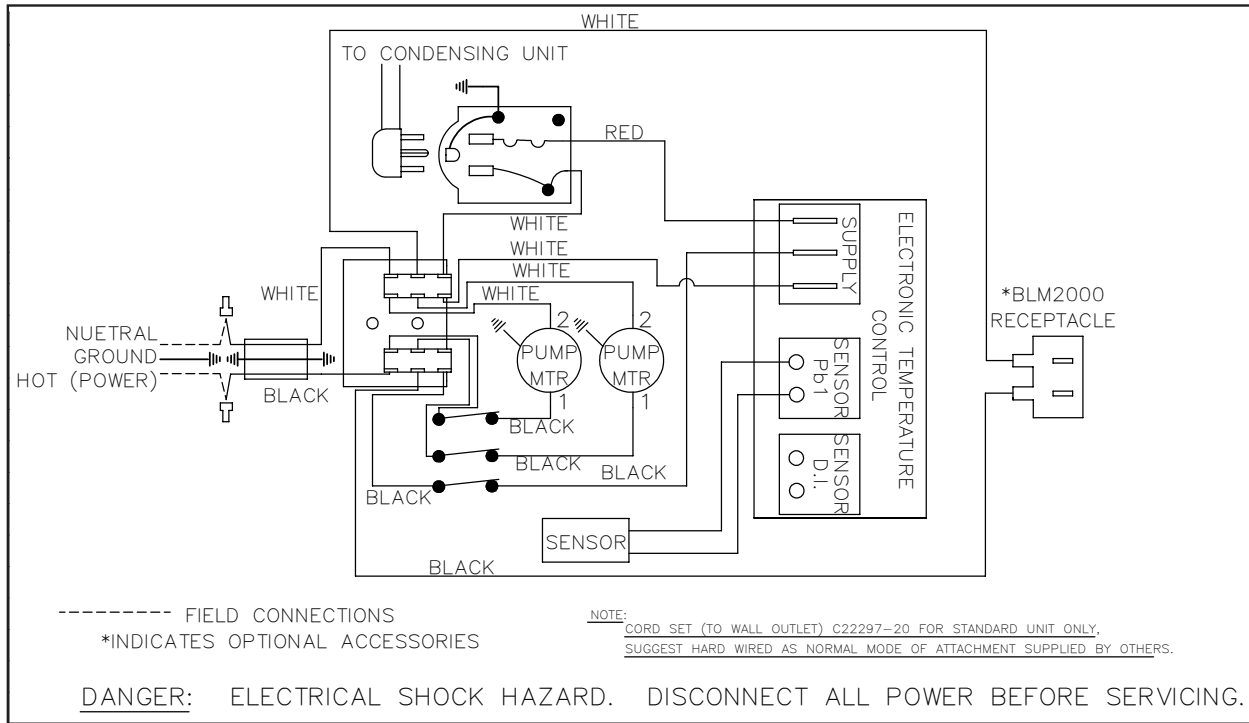

Wiring Diagram For 4420QC AC115 - 208/240, 60 HZ Power Paks (4 Wire AC Power Source Required)

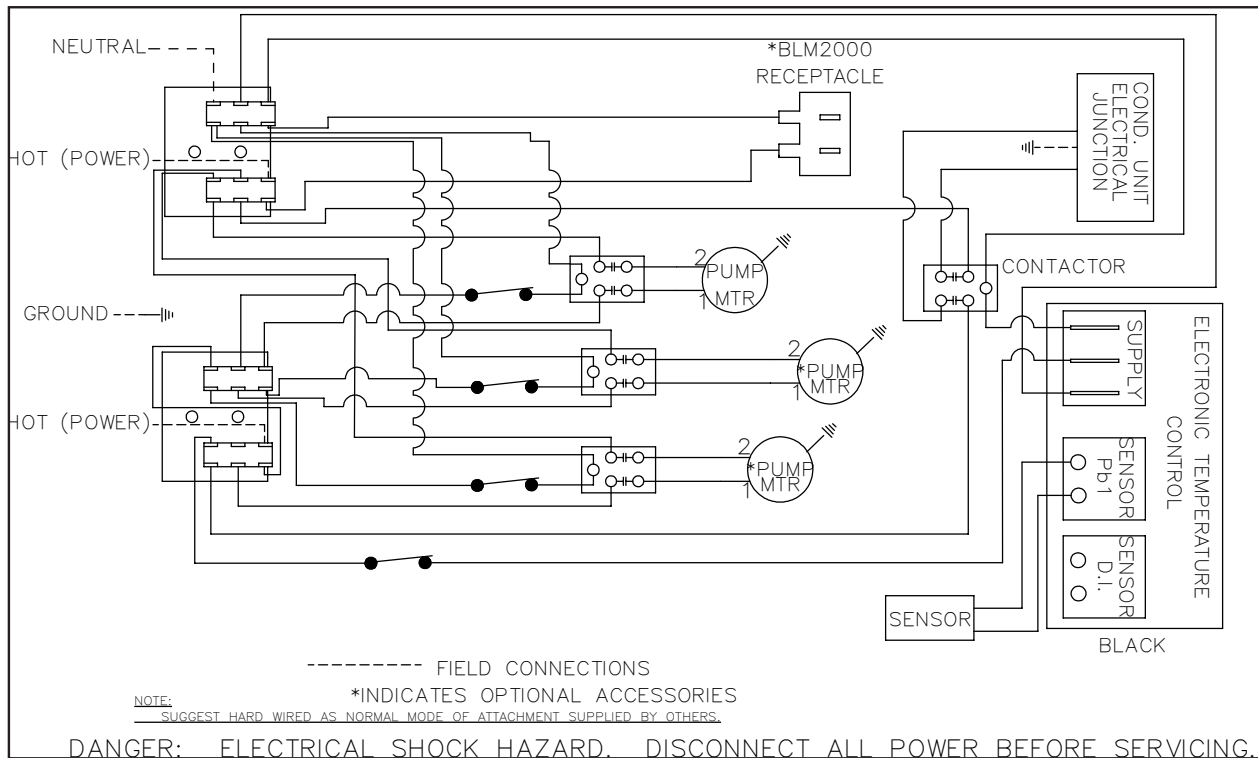

Perlick is committed to continuous improvement. Therefore, we reserve the right to change specifications without prior notice