



# SERVICE MANUAL

## Commercial Back Bar Refrigeration Self-Contained and Remote



BBS60  
(w/glass door option shown)



BBR96  
(w/glass door and solid stainless steel door options shown)

### Product Series Covered in this manual:

#### Self-Contained

- BBS
- BBSN
- PTS
- DZS
- SDBS
- SDPS
- BBSLP
- DDC
- DDS

#### Remote

- BBR
- BBRN
- PTR
- SDBR
- SDPR
- BBRLP

Scan here to  
download a pdf copy  
of this manual.





## Table of Contents

---

<b>1.0 GENERAL INFORMATION .....</b>	<b>1-1</b>
1.1 Use of Service Manual.....	1-1
1.2 Model Families .....	1-1
<b>2.0 SAFETY INFORMATION .....</b>	<b>2-1</b>
2.1 Refrigerant HFC-134a .....	2-1
2.2 Potential Problems with HFC-134a.....	2-1
2.3 Service Manual Safety Labels.....	2-1
<b>3.0 TROUBLESHOOTING GUIDE – REFRIGERATION SYSTEM.....</b>	<b>3-1</b>
<b>4.0 TROUBLESHOOTING GUIDE – ELECTRICAL SYSTEM.....</b>	<b>4-1</b>
<b>5.0 TROUBLESHOOTING GUIDE – DOORS, DRAWERS AND SHELVING .....</b>	<b>5-1</b>
<b>6.0 REFRIGERATION SYSTEM REPAIR INSTRUCTIONS .....</b>	<b>6-1</b>
6.1 Air Infiltration.....	6-1
6.2 Slide Out the Refrigeration Deck .....	6-2
6.3 Plumbing for Remote Drain .....	6-2
6.4 System Operating Pressures .....	6-3
6.4.1 First Time Pull Down .....	6-3
6.4.2 Normal Cycling.....	6-3
6.4.3 Stabilization.....	6-3
6.4.4 Service Values .....	6-3
6.5 De-Ice Blocked Evaporator Coil – Self-Contained Models.....	6-4
6.6 Air Flow Obstructions .....	6-5
6.7 Clean Condenser Coil .....	6-5
6.8 Ambient Temperature .....	6-5
6.10 Compressors and Condensing Unit .....	6-6
6.12 Replace Condenser Fan Motor .....	6-7
6.13 Replace Evaporator Fan Motor – Self-Contained Models .....	6-7
6.14 Replace Compressor .....	6-8
6.15 Leak Detection .....	6-8
6.16 Recharge Procedure.....	6-8
6.17 Replace compressor starting device – Self-contained models.....	6-9
<b>7.0 ELECTRICAL SYSTEM REPAIR INSTRUCTIONS.....</b>	<b>7-1</b>
7.1 Electrical Specifications .....	7-1
7.2 Wiring Diagrams.....	7-2
7.3 Load Operation Modes .....	7-23
7.4 Electronic Controller.....	7-23
7.5 Factory Set Point .....	7-24
7.5.1 Dixell Controller: Reset Factory Parameter Settings .....	7-24
7.5.2 Eliwell Controller: Reset Factory Parameter Settings.....	7-24



7.5.3	Replacing Control Module .....	7-25
7.5.3.1	Removing Dixell Controller.....	7-25
7.5.3.2	Installing Eliwell Controller.....	7-27
7.5.4	Temperature Probe .....	7-28
7.6	LED Lighting .....	7-28
7.6.1	Replace LED Light Strip .....	7-28
7.7	Replace DC Driver/Inverter.....	7-29
<b>8.0</b>	<b>SERVICE INSTRUCTIONS - DOORS, DRAWERS, AND SHELVING.....</b>	<b>8-1</b>
8.1	Proper Door and Drawer Usage .....	8-1
8.2	Reverse Door Swing.....	8-1
8.3	Replace Door Hinge .....	8-4
8.4	Sliding Door Models .....	8-4
8.4.1	Removing/Installing Sliding Doors .....	8-4
8.4.2	Adjusting Door Spring Tension.....	8-5
8.4.3	Torpedo Spring Adjustment .....	8-5
8.5	Drawer & Shelf Slides .....	8-5
8.5.1	Shelving Adjustment .....	8-5
8.5.2	Drawer Divider Adjustment.....	8-6
8.5.3	Cleaning/Lubricating Drawer Extenders .....	8-6
8.6	Replace Door & Drawer Gasket.....	8-6
8.7	Replace Door Handle .....	8-7
8.8	Locks.....	8-7
8.9	Custom Overlay Panels.....	8-7
<b>9.0</b>	<b>REPLACEMENT PARTS .....</b>	<b>9-1</b>
9.1	Refrigeration Module (BBS, BBSN, PTS, SDBS, SDPS, DDS, DDC Model Series) ...	9-1
9.2	Refrigeration Module (BBSLP Model Series).....	9-4
9.3	Refrigeration Module (DZS60 Model Series) .....	9-7
9.4	Refrigeration Module (DZS36 Model Series) .....	9-10
9.5	Refrigeration Module (DDS60-IR, DDS84-IR, DDS108-IR Model Series) .....	9-13
9.6	Fan Motor Assembly Parts (Self-Contained Model Series) .....	9-16
9.7	Low Profile Evaporator Parts (BBSLP Model Series).....	9-17
9.8	Remote Evaporator Parts (BBR, BBRN, PTR, SDBR & BBRLP Model Series) .....	9-18



## Table of Figures

Figure 1-1. Information Plate for Self-Contained Units.....	1-1
Figure 1-2. Information Plate for Remote Units.....	1-1
Figure 6-1. Sealing Compound at Wiring Pass-through .....	6-1
Figure 6-2. Floor Drain .....	6-1
Figure 6-3. Evaporator Condensate Trap .....	6-1
Figure 6-4. Remove Condensing Unit Bracket .....	6-2
Figure 6-5. Removing Refrigeration Deck .....	6-2
Figure 6-6. Remote Drain Tube .....	6-2
Figure 6-7. Service Valves.....	6-4
Figure 6-8. Removing Evaporator Fan Panel .....	6-4
Figure 6-9. Check for Obstructions.....	6-5
Figure 6-10. Fan Mounting Hardware.....	6-7
Figure 7-1. BBR24 Wiring Diagram .....	7-2
Figure 7-2. BBR48, BBR72, BBR96 Wiring Diagram .....	7-3
Figure 7-3. BBS36, BBS60, BBS84, BBS108 Wiring Diagram .....	7-4
Figure 7-4. BBSN32, BBSN52, BBSN72, BBSN92 Wiring Diagram .....	7-5
Figure 7-5. BBRN Wiring Diagram.....	7-6
Figure 7-6. BBRN60 and BBRN80 Wiring Diagram .....	7-7
Figure 7-7. PTS Wiring Diagram .....	7-8
Figure 7-8. PTR Wiring Diagram .....	7-9
Figure 7-9. DDS, DDC Wiring Diagram .....	7-10
Figure 7-10. BBRLP Wiring Diagram.....	7-11
Figure 7-11. Attach Probe to Bracket .....	7-27
Figure 7-12. Temperature Probe and Bracket .....	7-28
Figure 7-13. Interior LED Light.....	7-29
Figure 8-1. Door Removal.....	8-1
Figure 8-2. Hinge Removal.....	8-2
Figure 8-3. Hinge Installation .....	8-2
Figure 8-4. Door Brackets .....	8-2
Figure 8-5. Removing Front Panel.....	8-3
Figure 8-6. Bearing and V-Block .....	8-3
Figure 8-7. Door Hinges.....	8-3
Figure 8-8. Installing V-Block .....	8-4
Figure 8-9. Installing Door .....	8-4
Figure 8-10. Removing/Installing Sliding Door .....	8-4
Figure 8-11. Door Track.....	8-5
Figure 8-12. Shelf Locking Mechanism .....	8-5
Figure 8-13. Removing/Installing Drawer .....	8-6
Figure 8-14. Custom Panel.....	8-7



## Table of Tables

---

Table 6-1. System Operating Pressures.....	6-3
Table 6-2. Compressor Data.....	6-6
Table 7-1. Electrical Specifications.....	7-1
Table 7-2. Load Operation Modes.....	7-23
Table 7-3. Controller Where-Used Table.....	7-23
Table 7-4. Factory Temperature Settings.....	7-24
Table 7-5. Temperature – Resistance Values.....	7-28
Table 8-1. Door Hinges.....	8-1



## 1.0 General Information

### 1.1 Use of Service Manual

This service manual is intended for use by a qualified service technician. It is provided as a guide to diagnose and repair service issues for the product models listed on the cover.

If you have any questions or require additional assistance, contact Perlick Customer Service during regular hours of operation.

### 1.2 Model Families

This manual contains specific instructions for servicing the Perlick Back Bar commercial refrigeration products, which include the following families:

#### SELF-CONTAINED

BBS  
BBSN  
PTS  
DZS  
SDBS  
SDPS  
BBSLP  
DDC  
DDS

#### REMOTE

BBR  
BBRN  
PTR  
SDBR  
SDPR  
BBRLP

The model and serial numbers can be found on the left or right hand wall of the refrigerated space. See Figure 1-1 and Figure 1-2.



Figure 1-1. Information Plate for Self-Contained Units



Figure 1-2. Information Plate for Remote Units



## 2.0 Safety Information

### 2.1 Refrigerant HFC-134a

All self-contained models covered in this service manual are manufactured using refrigerant HFC-134a.

### 2.2 Potential Problems with HFC-134a

HFC-134a **compressors** are manufactured with a synthetic based ester oil charge.

- The hygroscopic (water attraction) property of ester oil is many times greater than that of the mineral oils previously used with CFC-12.
- High system moisture causes the formation of acids and alcohol, which can damage the compressor.
- Systems or components of the refrigeration system should not be left open to atmosphere for more than (15) minutes at any time as humidity from the air will enter the system and be absorbed by the oil.

To ensure system dehydration:

- System should be evacuated to a level less than **250** microns
- When isolated, shall not exceed 500 microns for a minimum of 10 minutes.
- Vacuum pump oil must never be allowed to enter the refrigeration system.
- No leak detection dyes are authorized for use within any Perlick Commercial Refrigeration Products.
- Use of these materials will void complete system warranty and place the burden on the service company for down-line service issues.

Cleanliness of the system is extremely important.

- The presence of residue (Chlorinated or greasy residues, mineral oil, or impurities) can lead to capillary tube restrictions, oil return problems and compressor damage.

- A nitrogen purge should be utilized when brazing.
- Flux **must not** be used on any brazed joints.

Anytime a Perlick Commercial Refrigeration System is being serviced:

- It is recommended that the drier be changed using the exact same style and size within the system to avoid possible charge problems or contaminant issues.

### 2.3 Service Manual Safety Labels

PLEASE READ all instructions completely before attempting to service the unit. Take particular note of the DANGER, WARNING and CAUTION information in this manual. The information is important for the safe and efficient service, operation and care of the Perlick unit.

#### **⚠ DANGER**

##### **HAZARD!!**

**Indicates hazardous situation that will result in death or serious injury if not avoided.**

#### **⚠ WARNING**

**Indicates hazardous situation that may result in death or serious injury if not avoided.**

#### **⚠ CAUTION**

**Caution indicates hazardous situation that could result in minor or moderate injury and property damage.**

#### **CAUTION**

Caution without symbol indicates unsafe practice situation that could result in property damage only.



### 3.0 Troubleshooting Guide – Refrigeration System

Use this diagnostic guide to identify issues and to locate applicable instructions within this service manual. This diagnostic guide can be used for any of Perlick’s Back Bar Refrigeration Products.

**⚠ DANGER**

**ELECTROCUTION HAZARD!!**  
**Never attempt to repair or perform maintenance on the unit until the Main electrical power has been disconnected.**

PROBLEM	CAUSE	SOLUTION
Refrigerator does not run.	No power to the unit.	Check circuit protection devices. Fuses, breakers, GFI). Restore power to unit. Refer to information plate. See Section 1.0 and Table 7-1.
	Incorrect control settings or faulty control.	Return to factory settings (see Sections 7.5.1 and 7.5.2) or replace control.
Refrigerator is too warm.	<b>Power</b>	
	No power to unit.	Restore power to unit. Refer to information plate. See Section 1.0 and Table 7-1.
	Incorrectly wired internal wiring connections.	Verify wiring per wiring diagram. See Section 7.2. Reconnect wires if needed.
	<b>Fans</b>	
	Evaporator fan is not running.	Refer to <a href="#">Evaporator fan is not running</a>
	<b>Coils</b>	
	Evaporator coil has iced over.	Remove ice. See Section 6.5
	Condensing coil is not clean.	Clean with soft brush and vacuum.
	Fins are bent or damaged.	Straighten fins.
	<b>Control</b>	
	No power to control.	Refer to <a href="#">Control not functioning</a>
	Control is not calling for cooling.	Refer to <a href="#">Control not functioning</a>
	Probe failure.	Refer to Table 7-5 for resistance values. Replace probe if needed. See Section 7.5.4.



PROBLEM	CAUSE	SOLUTION
	Probe is not connected to the control.	Reconnect probe. See Section 7.5.4.
Refrigerator is too warm. (continued)	<b>Air Infiltration</b>	
	Sealing compound does not form a complete seal.	Refer to Section 1.1.
	Door gasket is damaged or out of place.	Refer to Sections 1.1 and 8.6.
	Condensate drain line/air trap is not positioned properly.	Reposition in loop. See Figure 6-3.
Refrigerator is too cold.	Incorrect control settings.	Return to factory settings. See Sections 7.5.1 and 7.5.2.
	Probe failure.	Refer to Table 7-5 for resistance values. Replace probe if needed. See Section 7.5.4.
	Control failure.	Refer to Troubleshooting Guide – Electrical System
Refrigerator runs continuously.	Condensing coil is dirty.	Clean with soft brush and vacuum.
	Incorrect control settings.	Return to factory settings. See Sections 7.5.1 and 7.5.2.
	Probe failure.	Refer to Table 7-5 for resistance values. Replace probe if needed. See Section 7.5.4.
	Evaporator coil has iced over.	Remove ice per Section 6.5.
	Sealing compound does not form a complete seal.	Refer to Section 1.1.
	Door gasket is damaged or out of place.	Refer to Section 1.1 and 8.6.
	Condensate drain line/air trap is not positioned properly.	Reposition in loop. See Figure 6-3.
	Extreme ambient conditions.	Refer to Section 6.8.
	Refrigeration/Charge level is too low.	Check for leaks, repair, and recharge per Section 6.13 and 6.16.
Water on the floor outside of unit.	High ambient temperature and high ambient humidity conditions coupled with frequent door opening.	Ensure doors close completely.



PROBLEM	CAUSE	SOLUTION
	Condensate pan overflowing.	Remove excess water. Check for the following: <ul style="list-style-type: none"> <li>• Air infiltration. See Section 6.1.</li> <li>• Doors close completely and seals are intact. See Section 8.6.</li> <li>• Ice buildup. See Section 6.5.</li> <li>• Unit is running properly. Repair if needed.</li> </ul>
Water on the floor outside of unit. (continued)	Unit is not level.	Unit must be level front-to-back and side-to-side for water to drain properly.
	Sealing compound does not form a complete seal.	Refer to Section 1.1.
	Door gasket is damaged.	Refer to Sections 1.1 and 8.6.
	Remote ONLY: Floor drain plumbed incorrectly.	Check to make sure drain path makes sense. Refer to installation manual.
	Evaporator coil has iced over.	Remove ice. Refer to Section 6.5
Water on the floor inside of unit.	Evaporator pan and/or drain line restricted.	Remove restriction.
	Unit is not level.	Unit must be level front-to-back and side-to-side for water to drain properly.
	Evaporator coil has iced over.	Remove ice. Refer to Section 6.5



## 4.0 Troubleshooting Guide – Electrical System

PROBLEM	CAUSE	SOLUTION
Compressor is not running.	No power to condensing unit.	Check condensing unit is plugged in. Check power at internal receptacle.
	No call for cooling from control.	Check control settings or for bad control.
	Incorrectly wired connections in condensing unit.	Verify wiring per wiring diagram, Section 7.2. Reconnect wires if needed.
	Incorrect control settings.	Return to factory settings. See Sections 7.5.1 and 7.5.2.
	No power to compressor.	Restore power to unit. Refer to information plate. See Section 1.2 and Table 7-1
	Faulty control.	Refer to <a href="#">Control not functioning</a> .
	Starting device is not operational (start relay/capacitor).	Replace compressor electrical components.
	Faulty compressor.	Replace compressor per Section 6.14.
Condenser fan is not running.	No power to fan	Restore power to unit. Refer to information plate. See Section 1.0 and Table 7-1
	Incorrectly wired harness.	Verify wiring per wiring diagram, Section 7.2. Reconnect wires if needed.
	Fan is obstructed.	Remove obstructions.
	Fan still does not run.	Replace condenser fan per Section 6.13.
Evaporator fan is not running.	No power to evaporator fan motor.	Restore power to unit. Refer to information plate. See Section 1.0 and Table 7-1
	Fan is obstructed.	Remove obstruction.
	Incorrectly wired harness.	Verify wiring per wiring diagram, Section 7.2. Reconnect wires if needed.
	If Evaporator fan is still not running...	Replace evaporator fan per Section 6.13.
	BBSLP series ONLY: No power to/from DC inverter/driver (12V).	If no power: restore power, replace. Refer to Section 1.1.



PROBLEM	CAUSE	SOLUTION
Control not functioning	No power to unit.	Restore power to unit. Refer to information plate. See Section 1.0 and Table 7-1
	Incorrectly wired harness.	Verify wiring per wiring diagram, Section 7.2. Reconnect wires if needed.
	No call for cooling.	Replace controller
Lights not functioning	Light switch in off position.	Turn on light switch.
	No power to DC driver.	See unit info plate for voltage. Check output of DC driver (12V).
	No power to light switch. (12V)	Check wiring back to DC driver, replace if needed.
	Incorrectly wired lighting switch.	Verify wiring per wiring diagram, Section 7.2. Reconnect wires if needed.
	No power to LED strips? (12V)	Check wiring backwards to light switch.
	Faulty LED strip	Replace LED strip.
Light stays on when door is closed.	Manual switch is on.	Turn off manual switch.
Eliwell Control: LED Controller display is flashing "E1"	Probe 1 error. Reading out-of-range of operating values.	Check probe connections to control.
		Check probe resistance readings per Table 7-5.
		Check probe wiring.
		Replace probe per Section 7.5.3.
Eliwell Control: LED Controller display is flashing "AH1"	Probe 1 HIGH temperature alarm.	
	<b>Control</b>	
	Incorrect control settings.	Return to factory settings. See 7.5.1 and 7.5.2.
	<b>Power</b>	
	Incorrectly wired harness.	Verify wiring per wiring diagram, Section 7.2. Reconnect wires if needed.
	<b>Fans</b>	
	Evaporator fan is not running.	Refer to <a href="#">Evaporator fan is not running.</a>
	<b>Coils</b>	
Evaporator coil has iced over.	Remove ice. See Section 6.5	



PROBLEM	CAUSE	SOLUTION
Eliwell Control: LED Controller display is flashing "AH1" (continued)	<b>Coils</b> (continued)	
	Condensing coil is not clean.	Clean with soft brush and vacuum.
	Fins are bent or damaged.	Straighten fins.
	<b>Probe</b>	
	Probe is not connected to control.	Reconnect probe. See Section 7.5.4.
	<b>Air Infiltration</b>	
	Sealing compound does not form a complete seal.	Refer to Section 1.1.
	Door gasket is damaged or not seated properly.	Refer to Section 1.1 and 8.6.
	Condensate drain line/air trap is not positioned properly.	Reposition in loop. See <a href="#">Control not functioning</a> .
	Refrigeration/Charge level is too low.	Check for leaks, repair, and recharge. See Section 6.13 and 6.16. <b>This is a critically charged system, recharging should only be done when all other options have been thoroughly checked.</b>
Eliwell Control: LED Controller display is flashing "AL1"	Probe 1 LOW temperature alarm.	
	Incorrect control settings.	Return to factory settings. See Sections 7.5.1 and 7.5.2.
	Probe failure.	Refer to Table 7-5 for resistance values. Replace probe if needed. See Section 7.5.4.
	Control failure.	Refer to <a href="#">Control not functioning</a>
Dixell Control: LED Controller display is flashing "P1".	Probe failure.	Contact dealer.
	Probe disconnected from control.	Plug in probe connector.
Dixell Control: LED Controller display is flashing "HA". Maximum temperature alarm.	Internal compartment has exceeded the high temperature alarm preset value for over 30 minutes.	
	<b>Control</b>	
	Incorrect control settings.	Return to factory settings. See Sections 7.5.1 and 7.5.2.



PROBLEM	CAUSE	SOLUTION
Dixell Control: LED Controller display is flashing "HA". Maximum temperature alarm. (continued)	<b>Power</b>	
	Incorrectly wired harness and/or internal wiring connections.	Verify wiring per wiring diagram, Section 7.2. Reconnect wires if needed.
	<b>Fans</b>	
	Evaporator fan is not running.	Refer to <a href="#">Evaporator fan is not running</a>
	<b>Coils</b>	
	Evaporator coil has iced over.	Remove ice per Section 6.5.
	Condensing coil is not clean.	Clean with soft brush and vacuum.
	Fins are bent or damaged.	Straighten fins.
	<b>Probe</b>	
	Probe is not connected to the control.	Reconnect probe per Section 7.5.4.
	<b>Air Infiltration</b>	
	Sealing compound does not form a complete seal.	Refer to Section 1.1.
	Door gasket is damaged or out of place.	Refer to Section 1.1 and 8.6.
	Condensate drain line/air trap is not positioned properly.	Reposition in loop. See Figure 6-3.
Refrigeration/Charge level is too low.	Check for leaks, repair, and recharge per Section 6.13 and 6.16. <b>This is a critically charged system, recharging should only be done when all other options have been thoroughly checked.</b>	
Dixell Control: LED Controller display is flashing "LA". Minimum temperature alarm.	Internal compartment has exceeded the low temperature alarm preset value for over 30 minutes.	
	Incorrect control settings.	Return to factory settings. See 7.5.1 and 7.5.2.
	Probe failure.	Refer to Table 7-5 for resistance values. Replace probe if needed. See Section 7.5.4.
	Control failure.	Refer to <a href="#">Control not functioning</a>



## 5.0 Troubleshooting Guide – Doors, Drawers and Shelving

PROBLEM	CAUSE	SOLUTION
Key won't come out after door is locked.	Key not in proper position.	Rotate key to the proper position and remove.
Sliding doors not closing.	Replace spring and/or torpedo assembly.	Refer to Section 8.4.3.
Hinge problems, door falling off.	Improper door mounting	Verify proper mounting. Refer to Section 8-4.
	Excessive wear	Replace worn parts. Refer to Section 8-4.
Door handles falling off	Improper handle mounting	Verify proper mounting. Refer to diagram.
	Excessive wear	Replace worn parts. Refer to diagram.
Condensation on glass doors.	High ambient temperature, high humidity and environmental conditions.	Refer to Section 6.7.
	Frequent door/drawer opening.	Refer to Section 8.1.
	Cabinet temperature too low.	Adjust temperature. Refer to Table 7-4. Factory Temperature Settings.
Sliding doors dragging or binding	Debris in track.	Remove doors Clean tracks and lube with NSF approved food grade lube.

## 6.0 Refrigeration System Repair Instructions

### 6.1 Air Infiltration

Air infiltration can occur in several locations.

**Note:** Unit may manifest longer than normal run times caused by the additional loads that air infiltration presents.

Signs of air infiltration include:

- Presence of water, moisture or ice
- Condensation on glass or metal surfaces

#### STEP 1. Door Gaskets

Check door gaskets for rips, cracks, or other damage.

The door gasket should be pushed in firmly and lay flat.

Ensure gasket forms a complete seal around door.

#### STEP 2. Sealing Compound

Sealing compound is used to seal wiring and line set pass-through between the condenser and the evaporator compartments. See Figure 6-1.

Check for voids and ensure sealing compound completely fills the space.



Figure 6-1. Sealing Compound at Wiring Pass-through

#### STEP 3. Silicone Seal (RTV type)

Check for complete silicone seal of:

- Joint where rear wall meets ceiling
- Around evaporator coil compartment

#### STEP 4. Floor Drain

Check that interior floor drain plug is in place if not plumbed to external drain and completely tightened. Figure 6-2.

Check that the evaporator condensate trap is looped and full of water. Figure 6-3.



Figure 6-2. Floor Drain



Figure 6-3. Evaporator Condensate Trap



## 6.2 Slide Out the Refrigeration Deck

### STEP 1.

Remove grille by removing 1 Phillips head screw at the top center grille and 2 at the bottom edge.

### STEP 2.

Remove square bracket around the front of condensing unit by removing 6 Phillips screws and 2 hex head bolts. Figure 6-4

Pull the square bracket straight out.

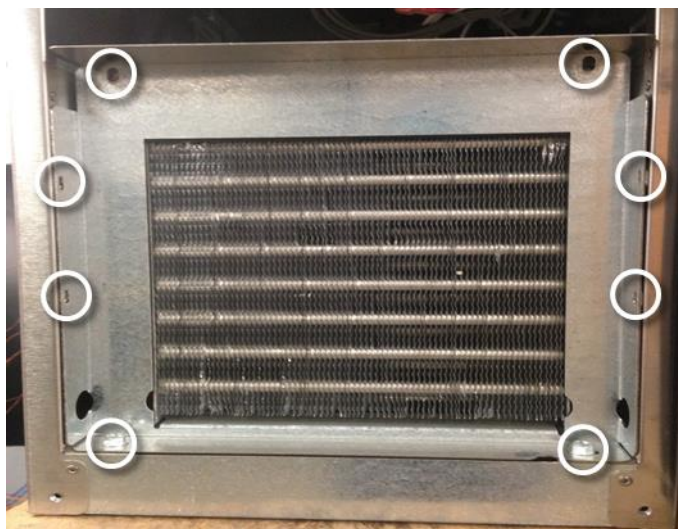

Figure 6-4. Remove Condensing Unit Bracket

### STEP 3.

The condensing unit/refrigeration deck can now be pulled straight out. Figure 6-5

Pull slowly and carefully to avoid damaging the copper line set.

- The copper line set is coiled with enough additional line to allow condensing unit to be removed from the cabinet.
- Do not place undue stress on copper lines when removing condensing unit.
- Damage/kinking of lines may occur if they are forcibly handled.



Figure 6-5. Removing Refrigeration Deck

## 6.3 Plumbing for Remote Drain

### STEP 1.

Remove panel to gain access to the evaporator drip pan.

### STEP 2.

Attach drain tube provided. See Figure 6-6.

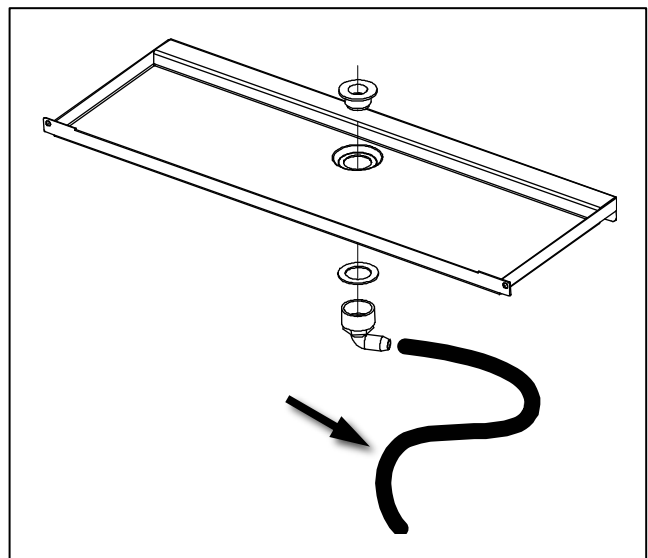

Figure 6-6. Remote Drain Tube

### CAUTION

Must be hooked up to an external floor drain, not floor inside unit or floor under unit.



## 6.4 System Operating Pressures

**Note:** To check operating pressures, you must gain access to the service valves. See Section 6.4.4.

### 6.4.1 First Time Pull-Down

After 7 minutes of intermediary speed, the speed is increased to maximum and it is kept at this rotation until the thermostat opens, switching the compressor off.

### 6.4.2 Normal Cycling

Compressor speed increases and decreases proportional to thermal load variation during compressor running time. Minimum speed will be targeted to minimize energy consumption.

### 6.4.3 Stabilization

If thermal load remains constant for a period longer than 20 minutes, the compressor speed is increased.

**Note:** The Compressor speed will be adjusted automatically by the Inverter, in accordance to the thermal load variation. (variable speed only)

Values in Table 6-1 represent a range of normal pressures. The measured pressure can vary depending on ambient conditions and at the point at which unit is in the refrigeration cycle.

*Table 6-1. System Operating Pressures*

	<b>RUNNING PRESSURE</b>
Low Side	15-20 PSIG
High Side	120-180 PSIG

### 6.4.4 Service Valves

#### STEP 1.

Remove the refrigeration deck (see Section 6.2), See Figure 6-5.

#### STEP 2.

Remove black caps. See Figure 6-7.

#### STEP 3. Recording pressure

When installing gauges:

1. Initially purge manifold set with refrigerant type used in unit. This avoids introduction of air into system.
2. Crack valve off back seat position to read pressures.
3. Allow unit to run for 10 minutes and stabilize before recording pressures.

When disconnecting hoses:

4. Initially back seat the high side service valve.
5. Open manifold on gauges to place high side liquid back into system and equalize gauges.
6. Then back seat low side service valve and remove gauges.



Service valve positions are as follows:

Fully Left Back seated with flow from refrigeration system closed.

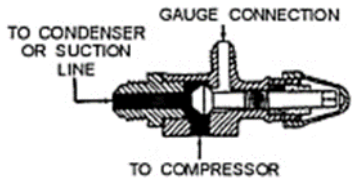

Middle Allows flow from the refrigeration system to the service port.

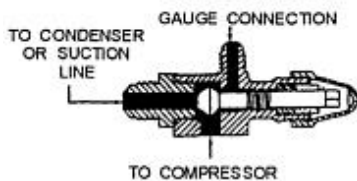

Fully Right Front seated with flow to the service port closed.

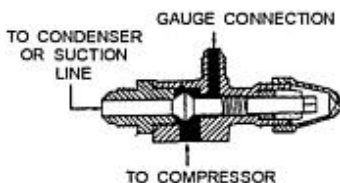

Figure 6-7. Service Valves

## 6.5 De-Ice Blocked Evaporator Coil – Self-Contained Models

### STEP 1.

Remove shelves and pilaster from refrigerator section nearest the evaporator coil.

### STEP 2.

Remove Evaporator Fan panel by removing 7 Phillips head screws from perimeter of panel. See Figure 6-8.



Figure 6-8. Removing Evaporator Fan Panel

### STEP 3.

Pull the handle and panel straight out from inner wall. The panel and connected fan can be placed on floor of cabinet.

### STEP 4.

Using a fan or heat gun to gently direct warm air over ice to remove.

## CAUTION

DO NOT use any tools to chip at or physically remove ice!

### STEP 5. When ice has been removed:

Check sealing compound. Re-forming, if necessary, to close any gaps around wire harness and piping.

Check for other potential sources of air infiltration. See Section 6.1.



## STEP 6.

Reverse steps 1 through 3 to close the evaporator fan panel.

### 6.6 Air Flow Obstructions

The unit must have free air flow to front grille to operate properly.

Restricted air flow results in high head pressures and reduction in efficiency due to longer run times.

Proper air flow around condensing unit and evaporator is necessary for efficient operation.

- Never obstruct air flow in and out of condensing unit.
- The front grille must be free from obstructions, dust, and debris.
- Never obstruct air flow to Evaporator Fan.
- Make sure higher temperature ambient air from another unit is not directed to condenser coil (i.e. another condensing unit directly across from the unit).
- Never place items in the area behind Product Side Guard/Handle. See Figure 6-9.

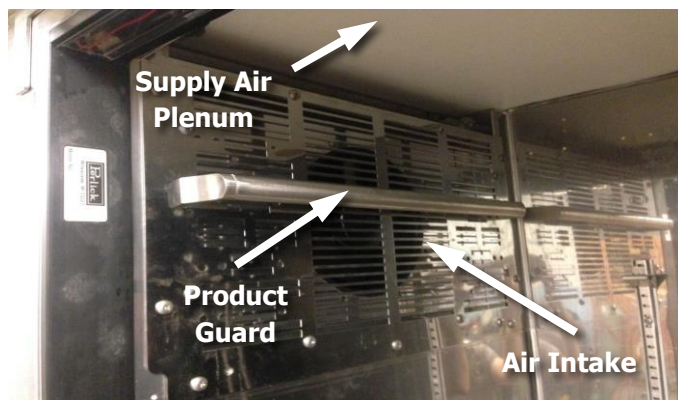

Figure 6-9. Check for Obstructions

### 6.7 Clean Condenser Coil

#### ⚠ DANGER

#### ELECTROCUTION HAZARD!!

**Never attempt to repair or perform maintenance on the unit until the Main electrical power has been disconnected.**

Perlick's warranty does not cover cleaning of condenser.

The condenser is located directly behind the front grille. See Figure 6-4.

Condenser coils that are covered with dust and debris restrict air flow. This results in high head pressures and lower efficiency due to longer run times.

Use soft brush and vacuum to clean coil every 90 days, or more often if conditions require.

### 6.8 Ambient Temperature

High ambient temperature and high humidity conditions may result in performance issues and/or refrigeration system failure.

The unit must be protected from precipitation.

Do not subject to direct solar load.

Under extreme temperature and/or relative humidity conditions the front face, gasket and/or glass door may show signs of condensation. When temperature and/or relative humidity conditions return to normal condensation will disappear.



## 6.10 Compressors and Condensing Unit (units shipped pre 3-27-2017 only)

Table 6-2. Compressor Data

MODEL /FAMILY	HP	WIRING	START WINDING RESISTANCE $\Omega$ AT 77°F	RUN WINDING RESISTANCE $\Omega$ AT 77°F	RUN/START
BBS36	1/5	RSIR	8.85	3.85	12.70
BBS60	1/4	CSIR	4.15	1.55	5.70
BBS84	1/3	CSIR	3.87	1.04	4.91
BBS108	1/3	CSIR	3.87	1.04	4.91
BBSN32	1/5	RSIR	8.85	3.85	12.70
BBSN52	1/4	CSIR	4.15	1.55	5.70
BBSN72	1/3	CSIR	3.87	1.04	4.91
BBSN92	1/3	CSIR	3.87	1.04	4.91
PTS36	1/5	RSIR	8.85	3.85	12.70
PTS60	1/4	CSIR	4.15	1.55	5.70
PTS84	1/3	CSIR	3.87	1.04	4.91
DZS36	1/5	RSIR	8.85	3.85	12.70
DZS60	1/4	CSIR	4.15	1.55	5.70
SDBS60	1/4	CSIR	4.15	1.55	5.70
SDBS108	1/3	CSIR	3.87	1.04	4.91
SDPS60	1/4	CSIR	4.15	1.55	5.70
BBSLP36	1/5	RSIR	8.85	3.85	12.70
BBSLP60	1/4	CSIR	4.15	1.55	5.70
BBSLP84	1/3	CSIR	3.87	1.04	4.91
BBSLP108	1/3	CSIR	3.87	1.04	4.91
DDC68	1/4	CSIR	4.15	1.55	5.70
DDC92	1/3	CSIR	3.87	1.04	4.91
DDS36	1/5	RSIR	8.85	3.85	12.70
DDS60	1/4	CSIR	4.15	1.55	5.70
DDS84	1/3	CSIR	3.87	1.04	4.91
DDS108	1/3	CSIR	3.87	1.04	4.91



## 6.12 Replace Condenser Fan Motor

### STEP 1.

Remove Refrigeration Deck. See Section 6.2.

### STEP 2.

Unplug the fan power cord from beneath electrical box on compressor.

### STEP 3.

Remove fan motor assembly by removing 4 Phillips head screws that hold the fan bracket.



Figure 6-10. Fan Mounting Hardware

### STEP 4.

Install new fan motor assembly by attaching the bracket with 4 screws.

### STEP 5.

Install refrigeration deck by reversing steps in section 6.2.

## 6.13 Replace Evaporator Fan Motor – Self-Contained Models

### STEP 1.

Remove grille by removing 3 Phillips head screws, one at the top center and two at the bottom edge.

### STEP 2.

Cut 2 zip ties holding wire harness to top of the refrigeration module.

### STEP 3.

Disconnect evaporator fan wire leads from main wiring harness.

### STEP 4.

Remove sealing compound from top and bottom of wire pass-through located inside evaporator box and inside of machine compartment.

### STEP 5.

Remove shelving from unit, as well as shelf bracket on left wall.

### STEP 6.

Remove 7 screws holding evaporator fan panel to unit. Figure 8-7

### STEP 7.

Tip evaporator fan assembly down and remove from unit. Pull evaporator fan wires up through the top of the machine compartment.

### STEP 8.

Remove 8 screws to separate front and back of evaporator fan panel.

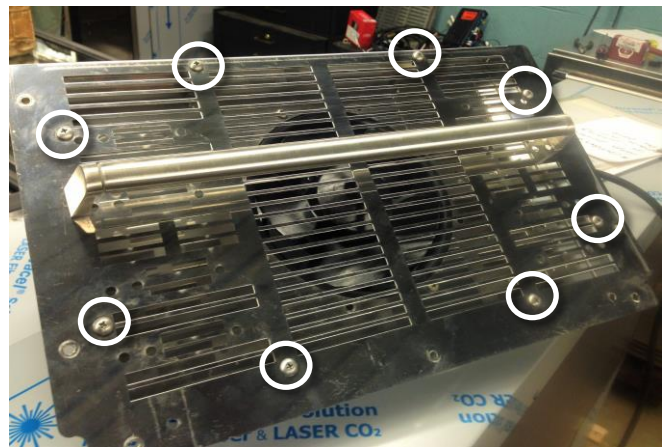

**STEP 9.**

Remove 8 fan mounting screws.

**STEP 10.**

Evaporator fan motor can now be replaced. Evaporator fan motor should only be replaced with Perlick OEM parts.

**STEP 11.**

Reverse steps 1-9 to close the unit.

**6.14 Replace Compressor**

To gain access to compressor, follow instructions in Section 6.2.

Compressor should only be replaced with Perlick OEM parts.

Always replace drier when replacing compressor.

**6.15 Leak Detection**

If during a check of operating system pressures, it is determined that refrigerant level is low, you must perform a leak test.

- Do not recharge a system without first determining where original refrigerant charge exited the sealed system!
- Placing a system that has lost refrigerant under a vacuum without first repairing the leak will draw contaminants into the system through the point of leak. Find source of the leak and correct it!

- The use of an electronic leak detector is highly encouraged.
- If the entire charge has leaked out of the unit, the sealed system should be pressurized with 200 lbs. of dry nitrogen and tracer refrigerant. Then use an ultrasonic leak detector or a soap and water solution to pinpoint the location of the leak.
- Be certain to check all brazed connections thoroughly for leaks. Look for spots where the sealed system components might have been worn through by structural or cabinet components.
- Check the service ports thoroughly for leaks as well.

**6.16 Recharge Procedure****STEP 1.**

Check that the system been properly installed, pressure tested, and evacuated.

**STEP 2.**

Condenser and evaporator must be clean. Evaporator fan and condenser fan blades must be able to move the correct amount of air.

**STEP 3.**

Before installing gauges, vent hoses and manifold with refrigerant type used in unit. This avoids introduction of air into system.

Continue to next page...



**STEP 4.**

Service valve positions are as follows:

Fully Left Back seated with flow from refrigeration system closed.

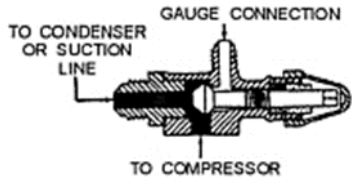

Middle Allows flow from the refrigeration system to the service port.

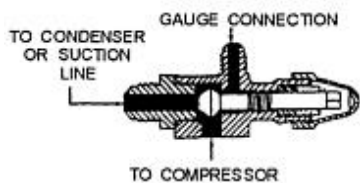

Fully Right Front seated with flow to the service port closed.

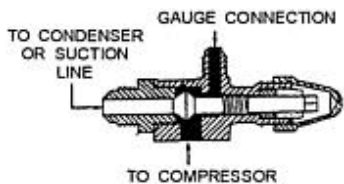

**STEP 5.**

Charge level is listed on unit information plate.

**CAUTION**

Once charge level has been set, avoid installing gauges as part of regular service. System should be kept sealed.

Do not "top off" or add refrigerant to an unknown existing charge.

Completely reclaim existing refrigerant in accordance with EPA regulations and thoroughly evacuate the system.

After evacuating the system:

1. Break vacuum with refrigerant.

2. Purge system through the high side until a nominal amount of refrigerant is purged out of the low side.
3. Then "weigh in" the correct total charge into system.

**6.17 Replace compressor starting device – Self-contained models**

**STEP 1.**

Completely slide out refrigeration deck. See Section 6.2.

**STEP 2.**

Pry open gray cover. Starting device is now accessible.



Overload device and capacitor are also accessible.





## 7.0 Electrical System Repair Instructions

### 7.1 Electrical Specifications (units shipped pre 3-27-2017 only)

Verify adequate power is supplied.

Table 7-1. Electrical Specifications

Unit Type	Model Number	Running Load Amps	Electrical Supply	Electrical Connection
Self-Contained	BBS36	3.2	120 VAC/60 Hz/1 Ph	Cord Connected
	BBS60	5.5		
	BBS84	6.3		
	BBS108	6.3		
	BBSLP36	3.0		
	BBSLP60	5.3		
	BBSLP84	6.7		
	BBSLP108	6.7		
	BBSN32	3.2		
	BBSN52	5.5		
	BBSN72	6.3		
	BBSN92	6.3		
	DDS36	3.2		
	DDS60	5.5		
	DDS84	6.3		
	DDS108	6.3		
	DDC68	5.5		
	DDC92	6.3		
	DZS36	3.2		
	DZS60	5.5		
	PTS36	3.2		
PTS60	5.5			
PTS84	6.3			
SDBS60	5.5			
SDBS108	6.3			
SDPS60	5.5			
Remote	BBR24	1.1	120 VAC/60 Hz/1 Ph	Hard Wired
	BBR48	1.6		
	BBR72	2		
	BBR96	2.5		
	BBRLP48	1.6		
	BBRLP72	2		
	BBRLP96	2.5		
	BBRN40	1.6		
	BBRN60	2		
	BBRN80	2.5		
	PTR48	1.6		
	PTR72	2		
	SDBR48	1.6		
	SDBR96	2.5		
	SDPR48	1.6		



## 7.2 Wiring Diagrams

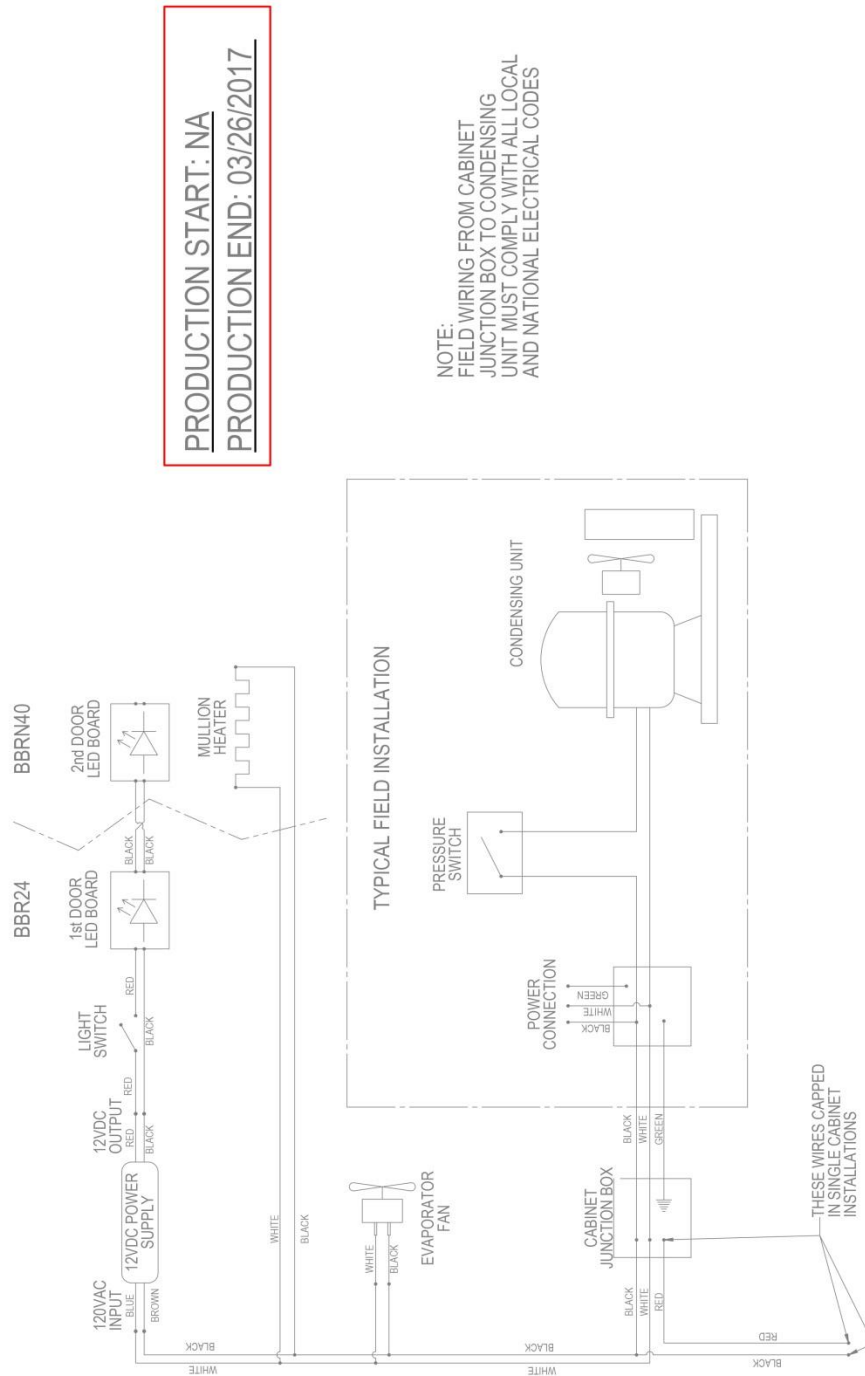

Figure 7-1. BBR24, BBRN40 Wiring Diagram

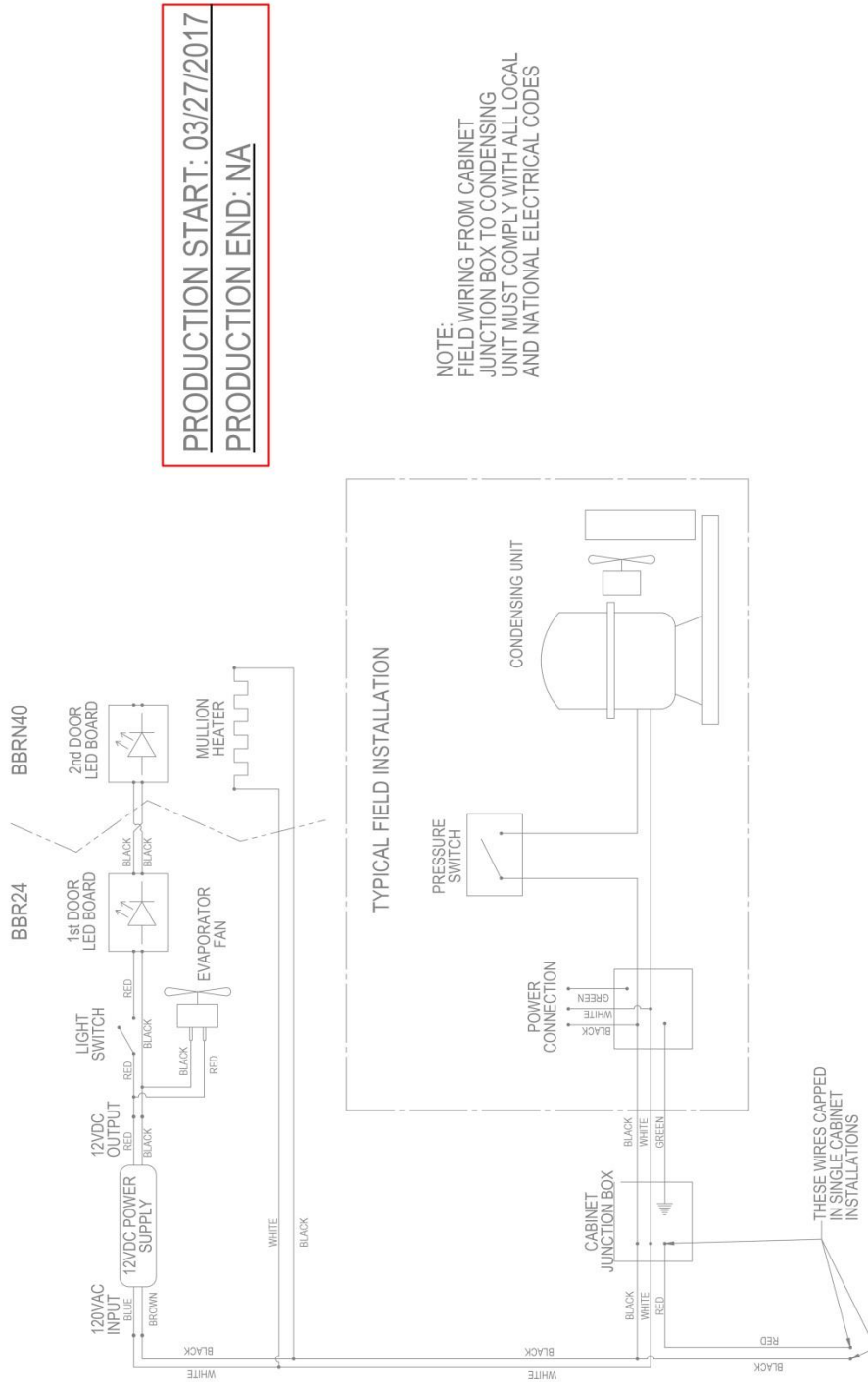

Figure 7-1. BBR24, BBRN40 Wiring Diagram



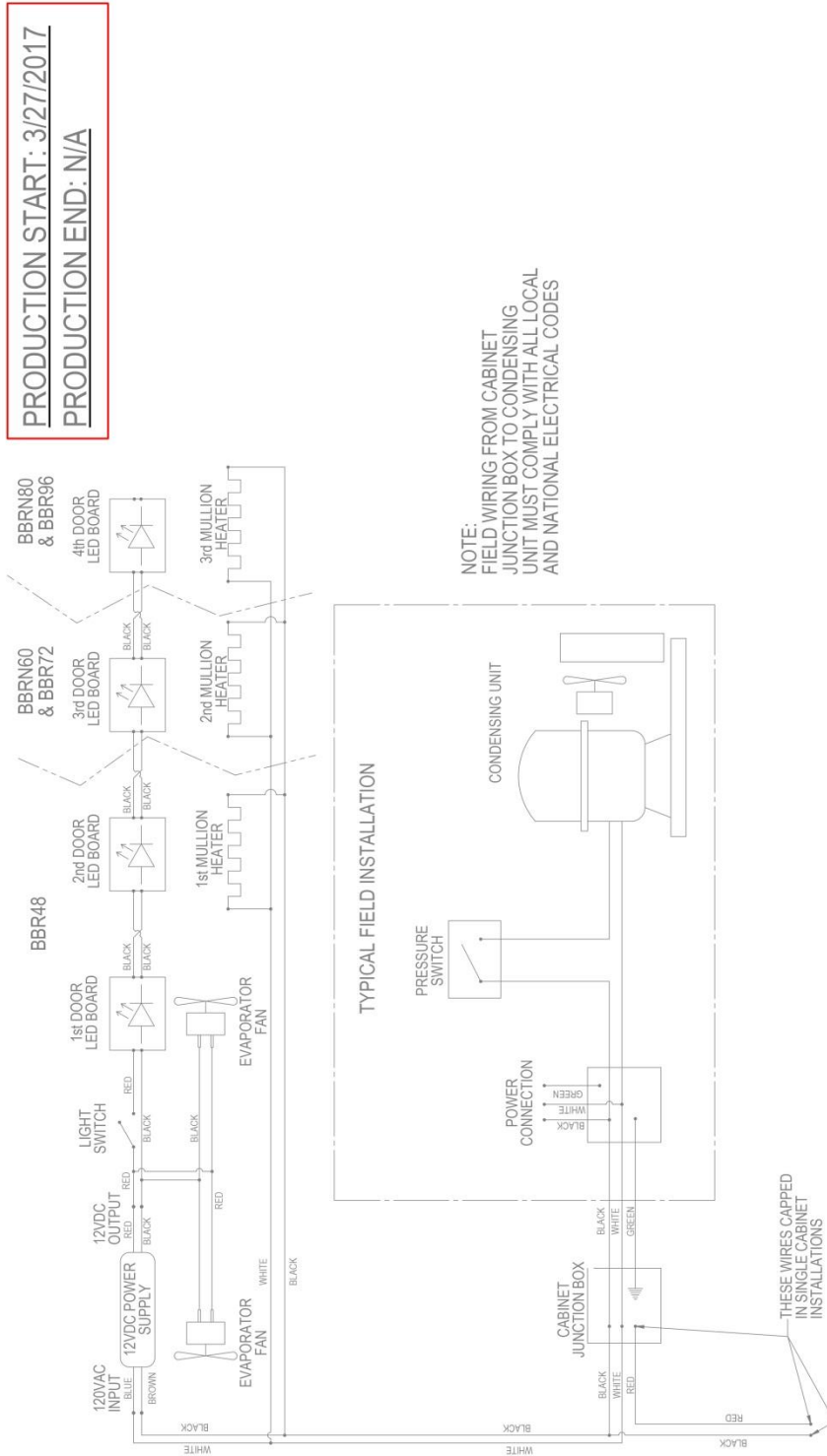

Figure 7-2. BBR48, BBR72, BBR96, BBRN60, BBRN80 Wiring Diagram

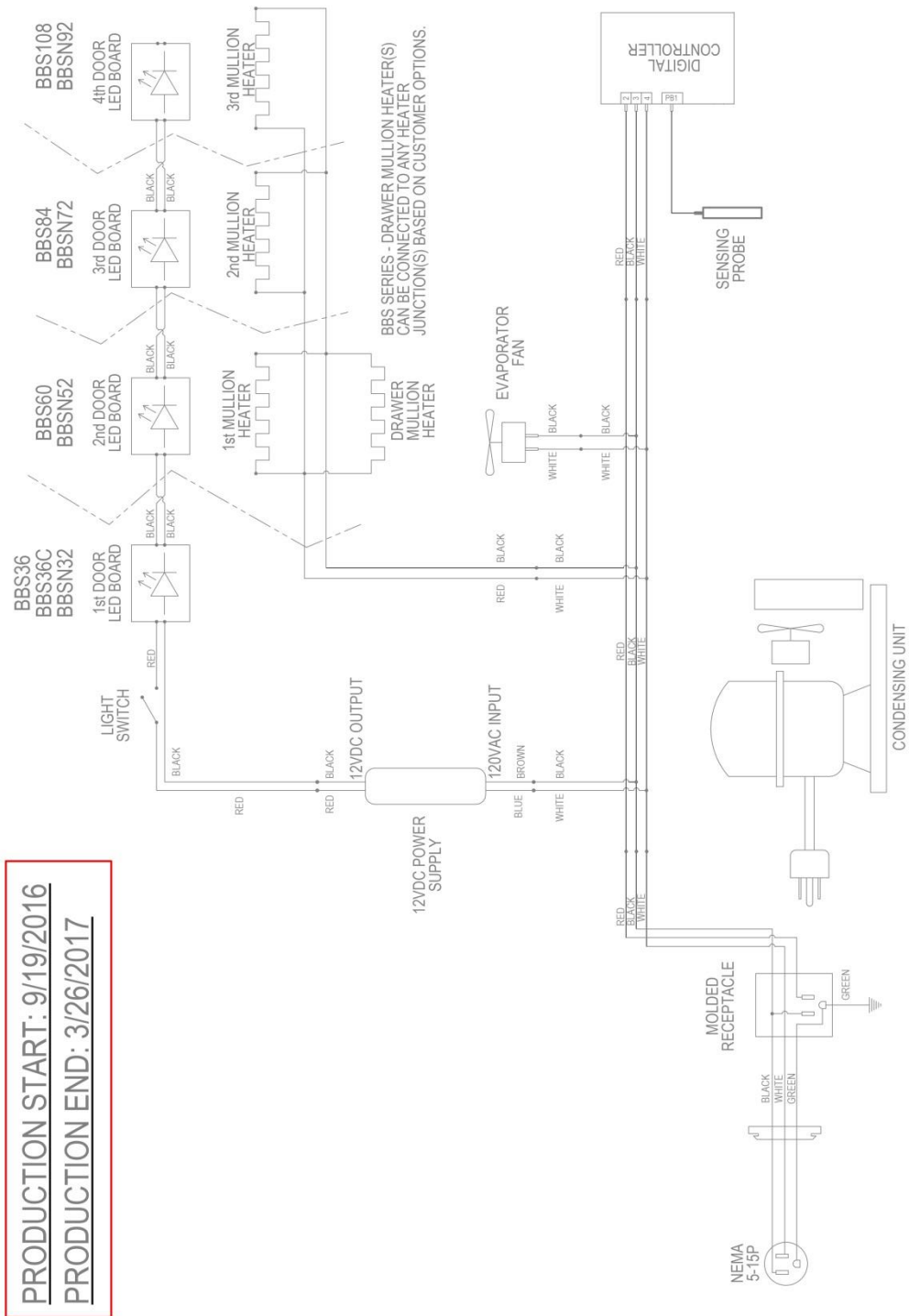

Figure 7-3. BBS36, BBS60, BBS84, BBS108, BBSN32, BBSN52, BBSN72, BBSN92 Wiring Diagram

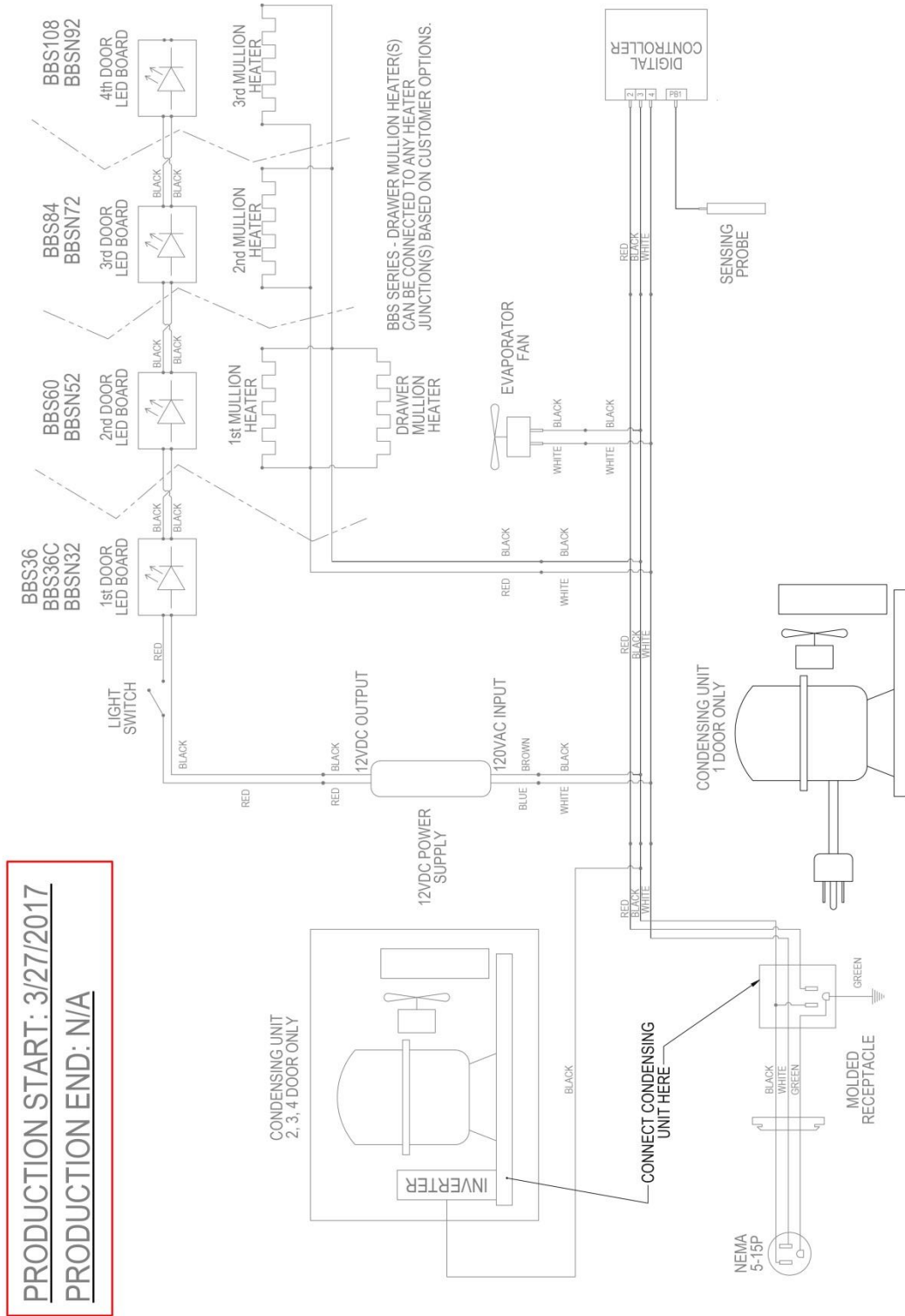

Figure 7-3. BBS36, BBS60, BBS84, BBS108, BBSN32, BBSN52, BBSN72 and BBSN92 Wiring Diagram

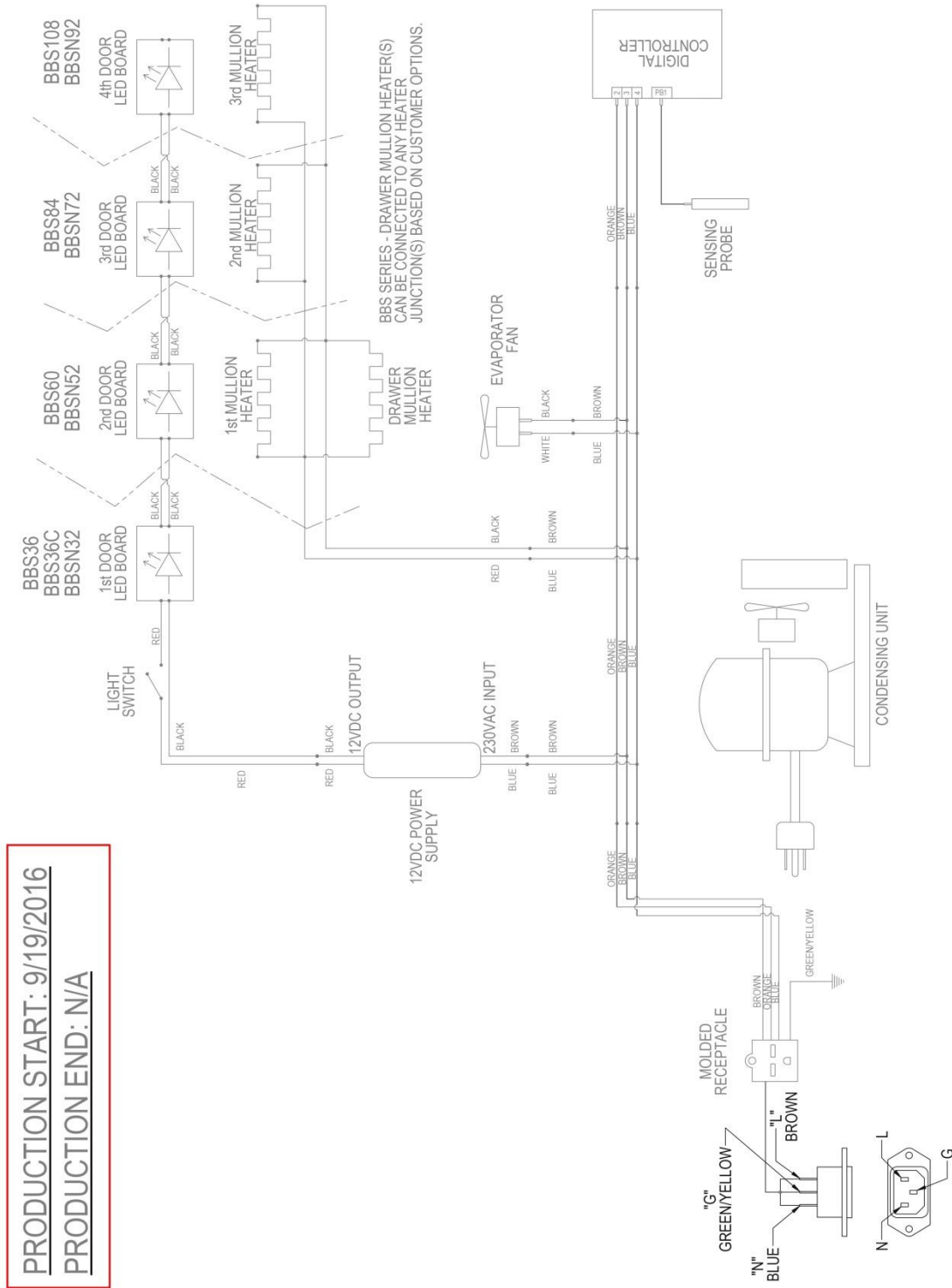

Figure 7-3. BBS36, BBS60, BBS84, BBS108, BBSN32, BBSN52, BBSN72 and BBSN92 Wiring Diagram

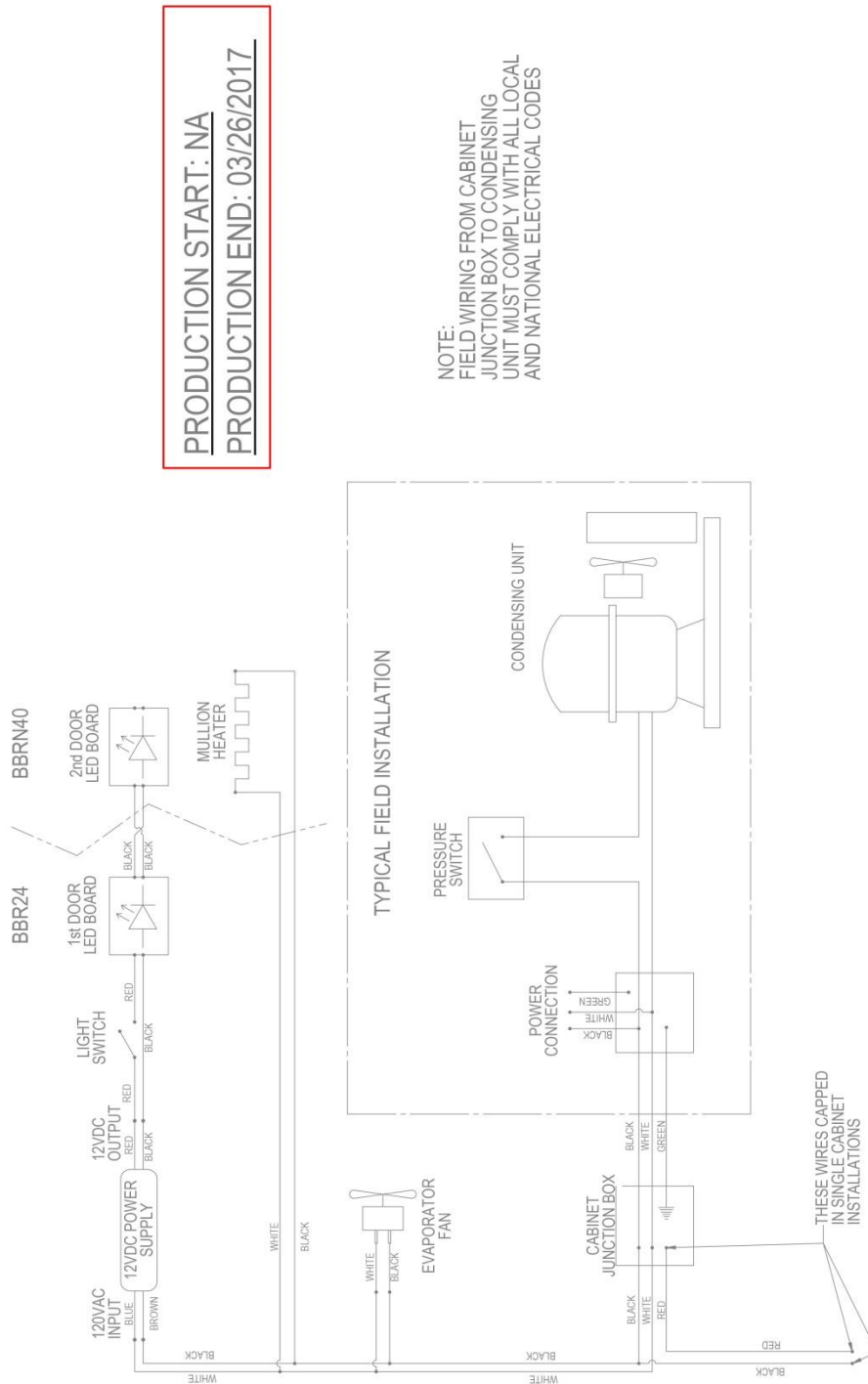

Figure 7-4. BBR24, BBRN40 Wiring Diagram

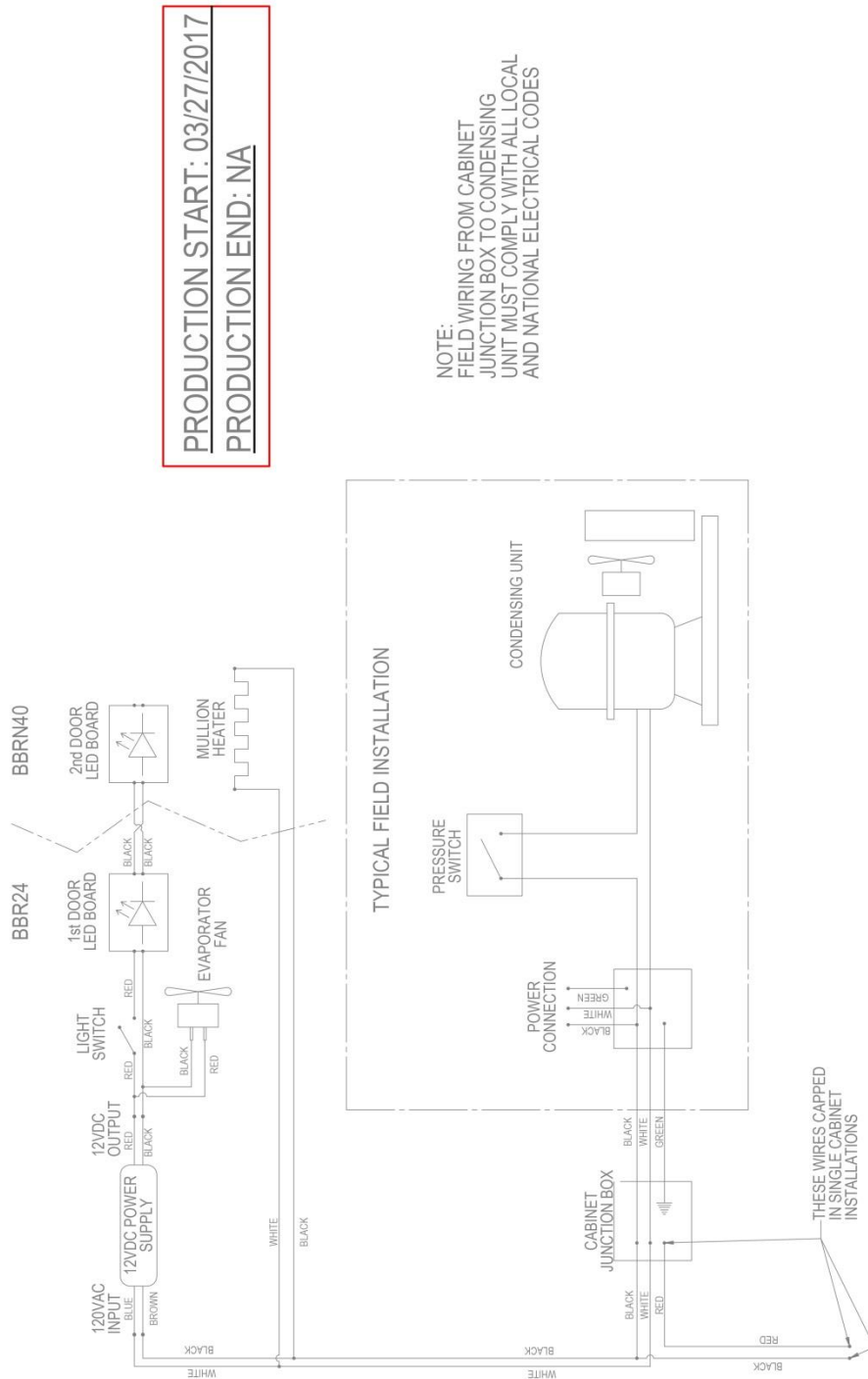

Figure 7-4. BBR24, BBRN40 Wiring Diagram

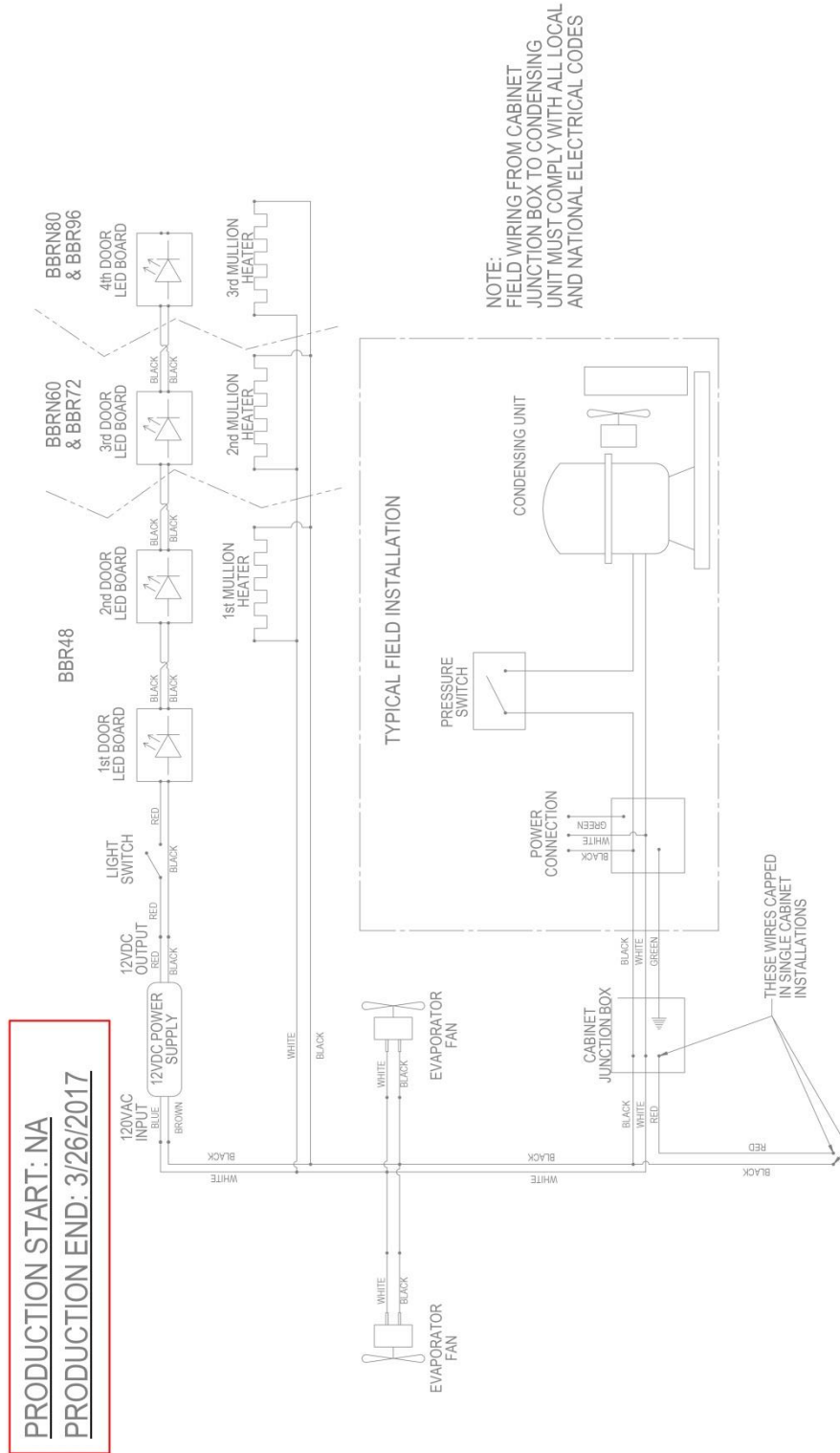

Figure 7-5. BBR48, BBR72, BBR96, BBRN60 and BBRN80 Wiring Diagram

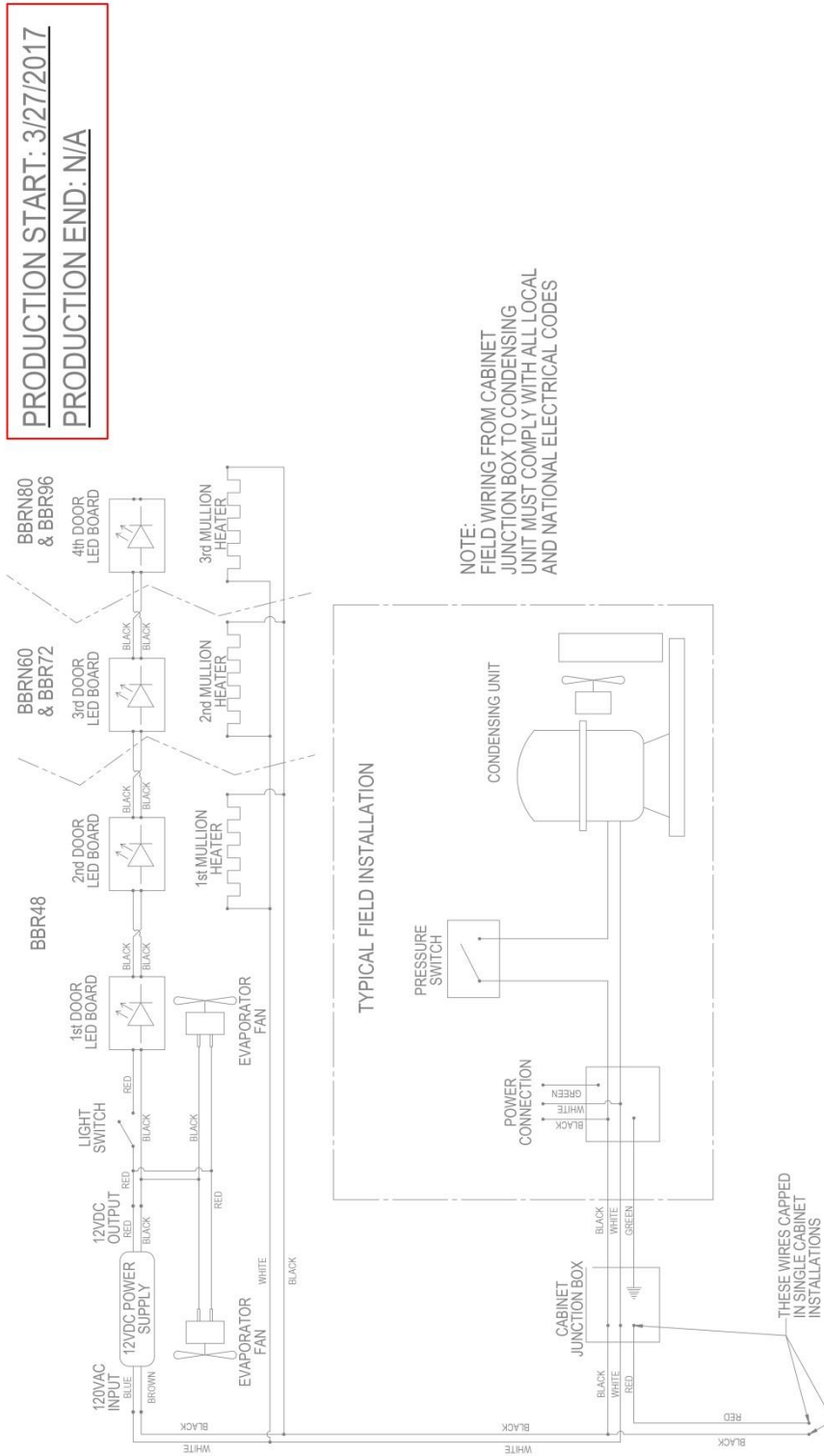
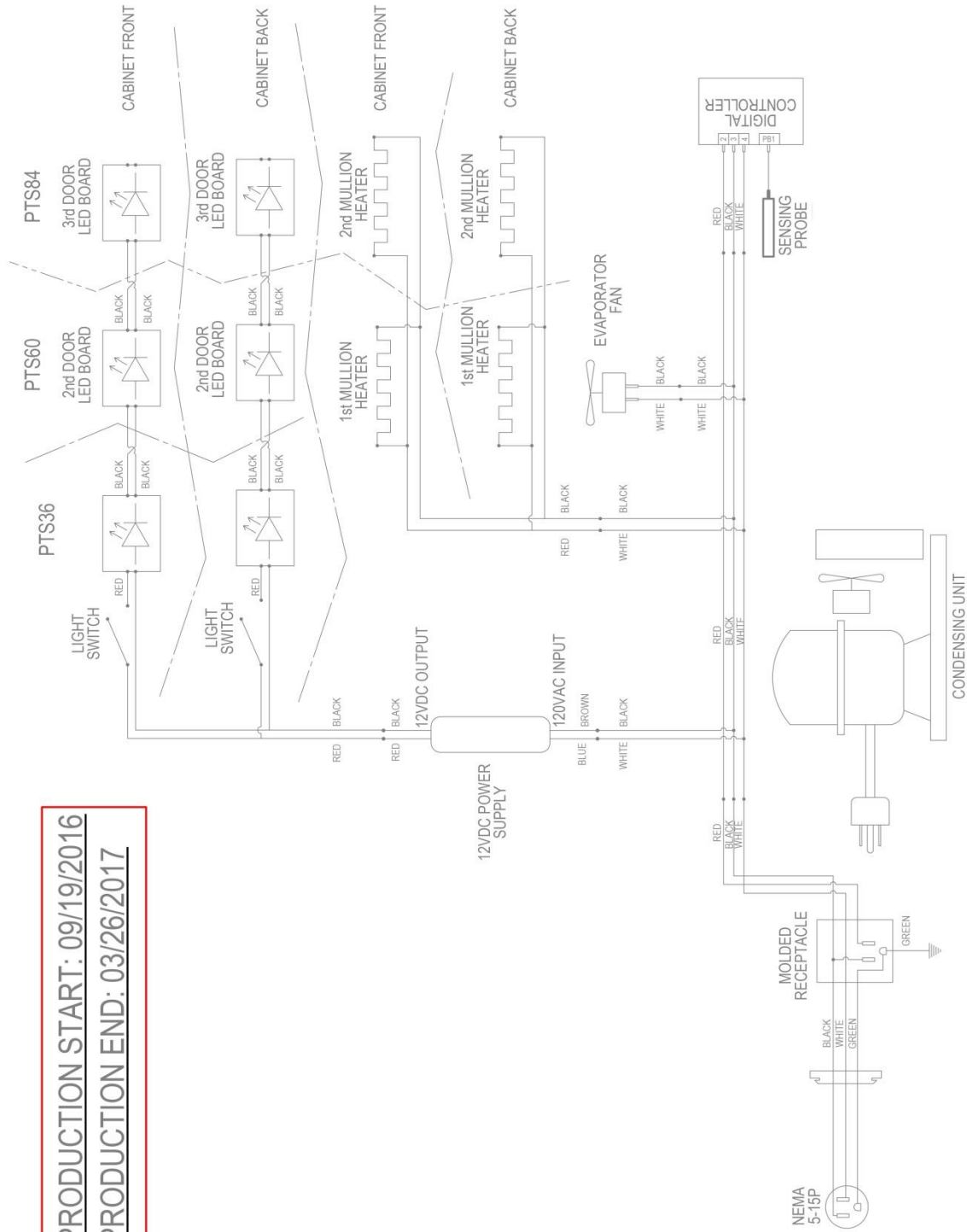

Figure 7-5. BBR48, BBR72, BBR96, BBRN60 and BBRN80 Wiring Diagram



PRODUCTION START: 09/19/2016  
 PRODUCTION END: 03/26/2017

Figure 7-6. PTS36, PTS60, PTS84 Wiring Diagram

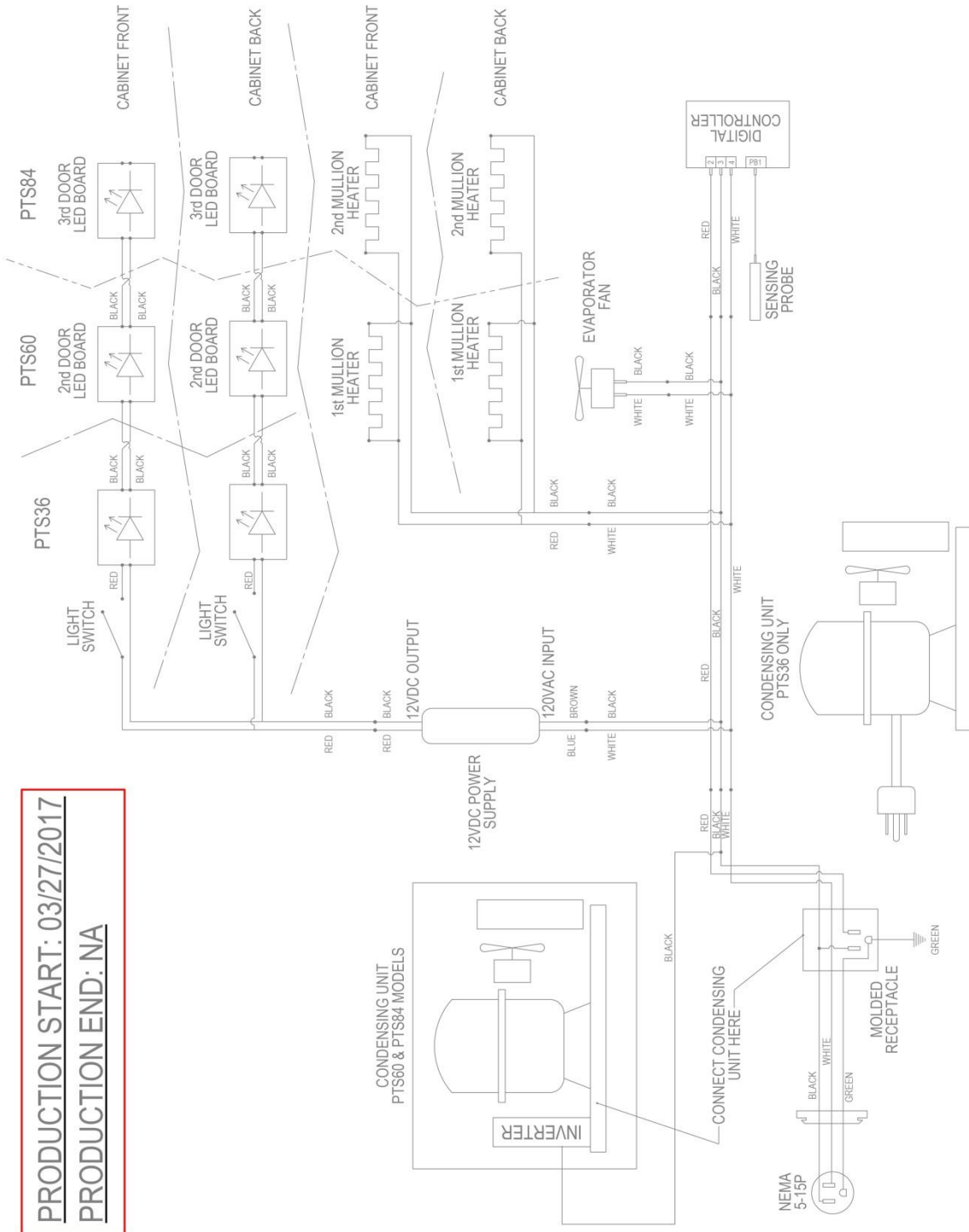
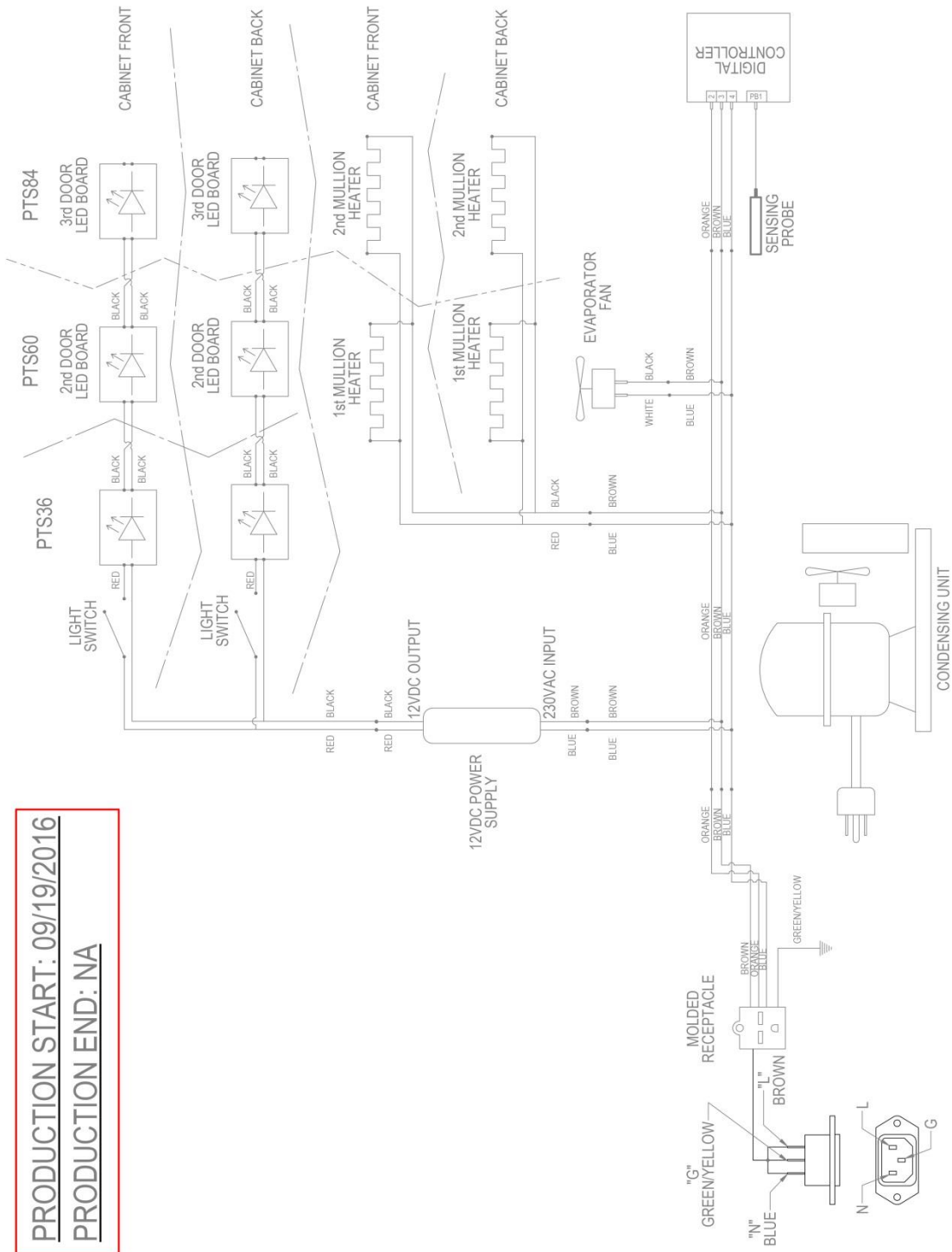

Figure 7-6. PTS36, PTS60, PTS84 Wiring Diagram



PRODUCTION START: 09/19/2016  
 PRODUCTION END: NA

Figure 7-6. PTS36, PTS60, PTS84 Wiring Diagram

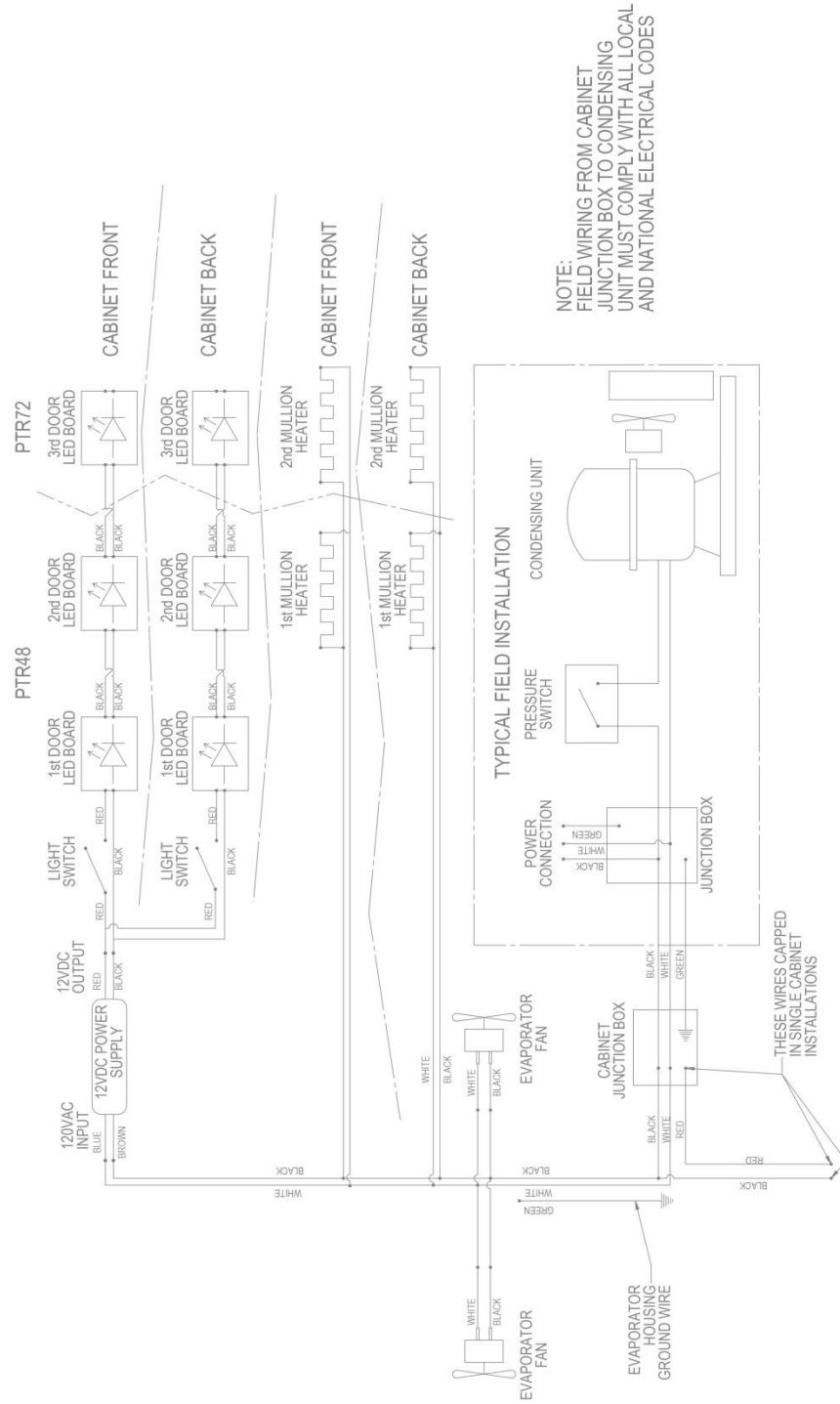

Figure 7-7. PTR48, PTR72 Wiring Diagram

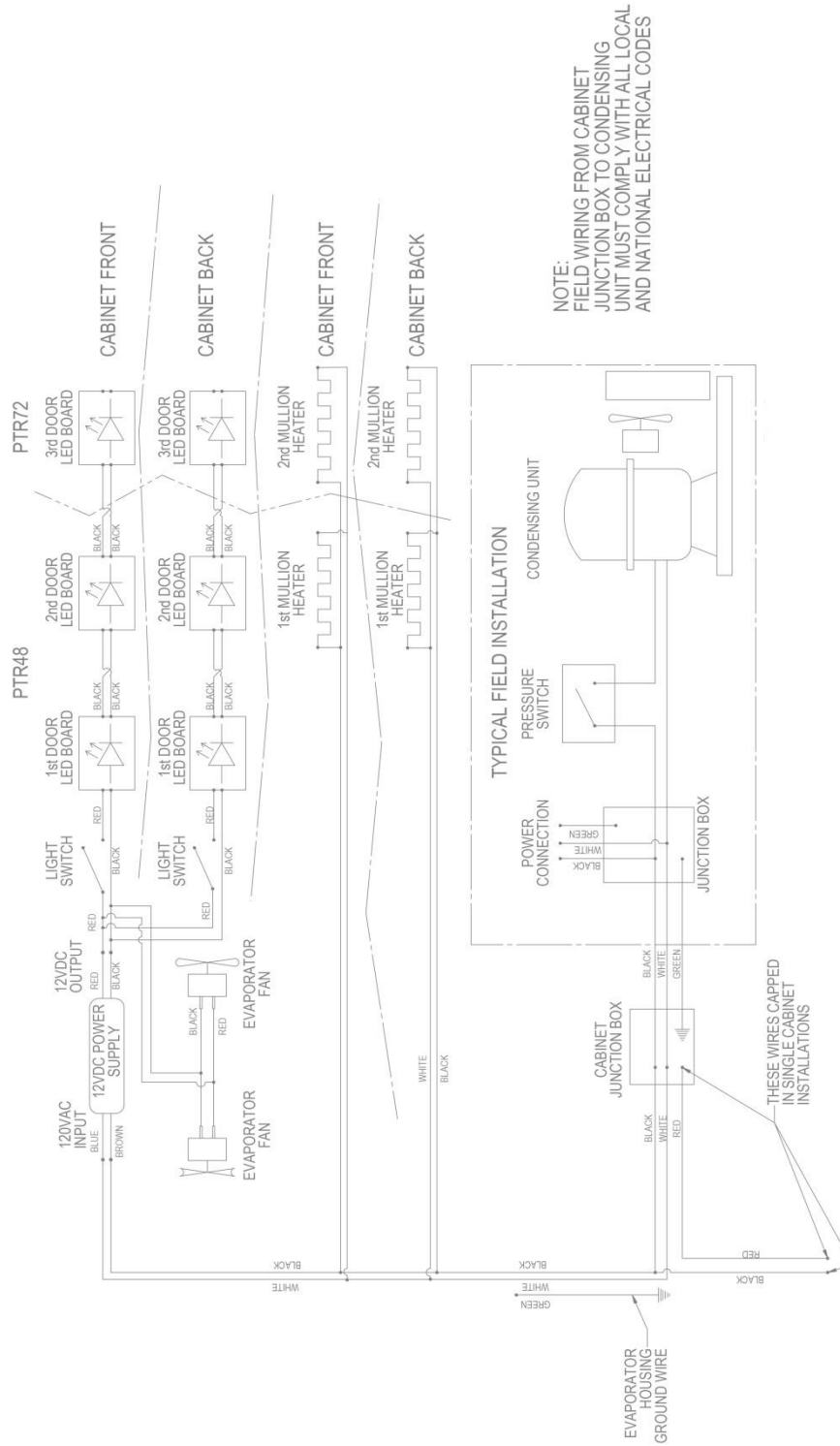

Figure 7-7. PTR48, PTR72 Wiring Diagram



PRODUCTION START: 09/19/2016  
 PRODUCTION END: 03/26/2017

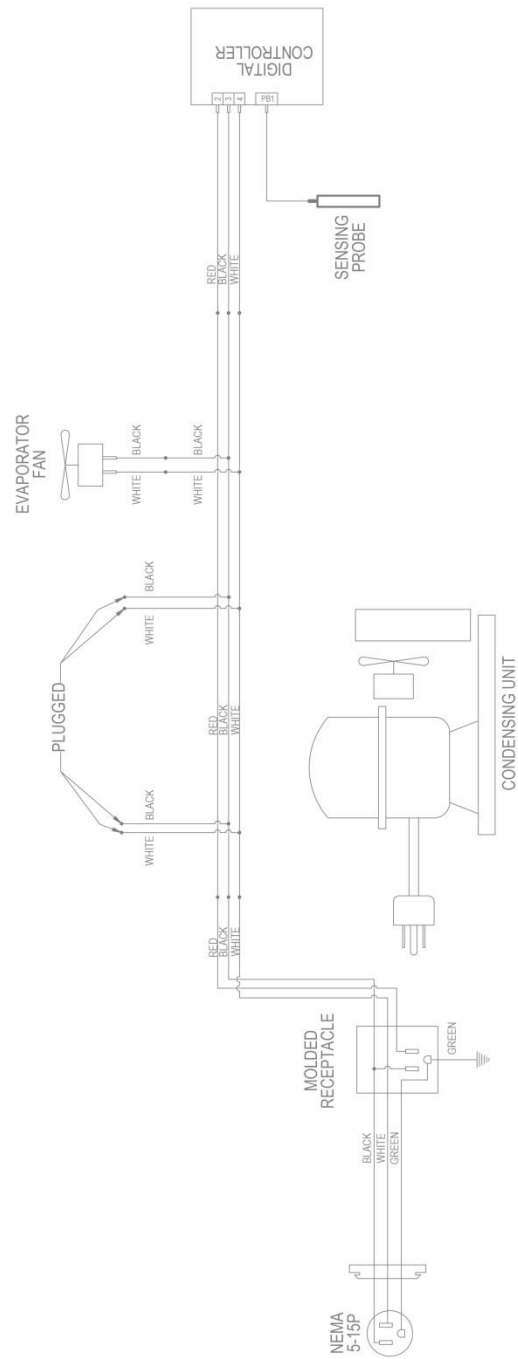

Figure 7-8. DDS, DDC Wiring Diagram



PRODUCTION START: 3/27/2017  
 PRODUCTION END: N/A

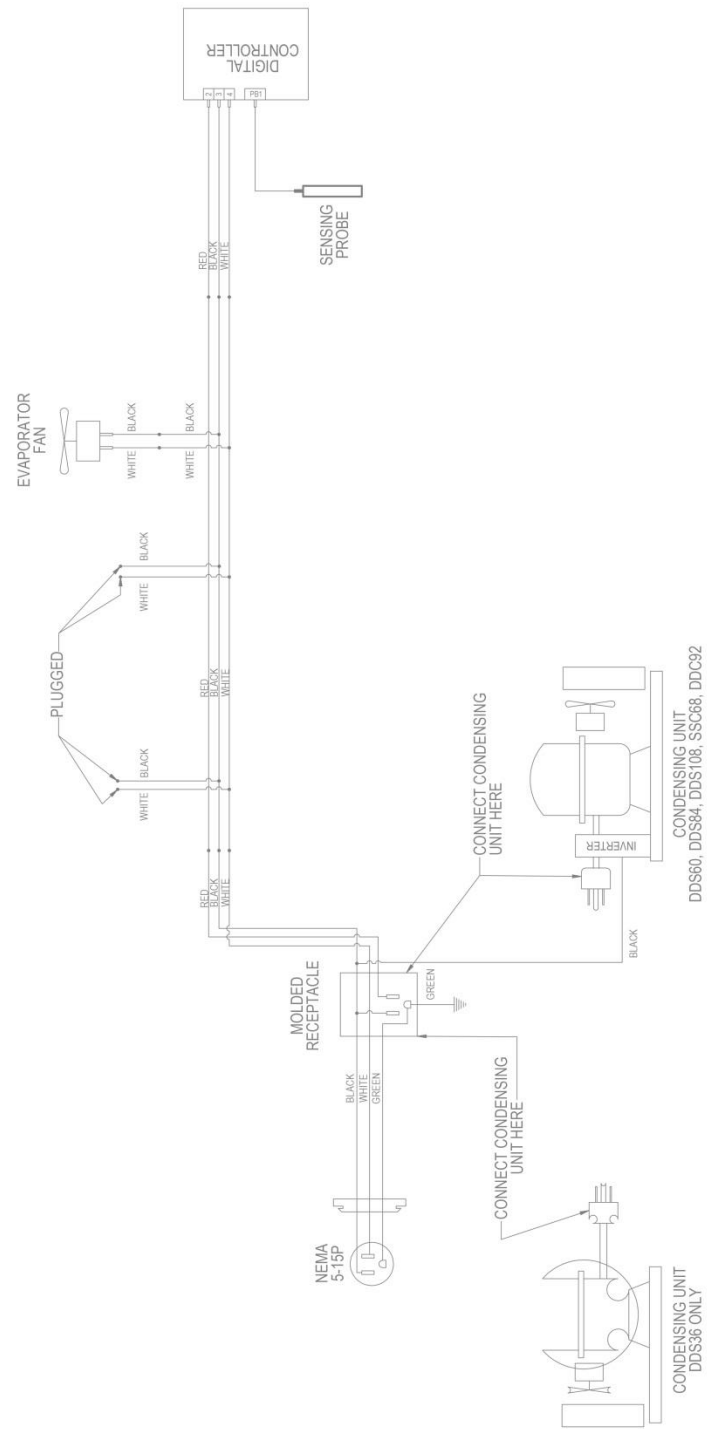

Figure 7-8. DDS, DDC Wiring Diagram



PRODUCTION START: 09/19/2016  
 PRODUCTION END: N/A

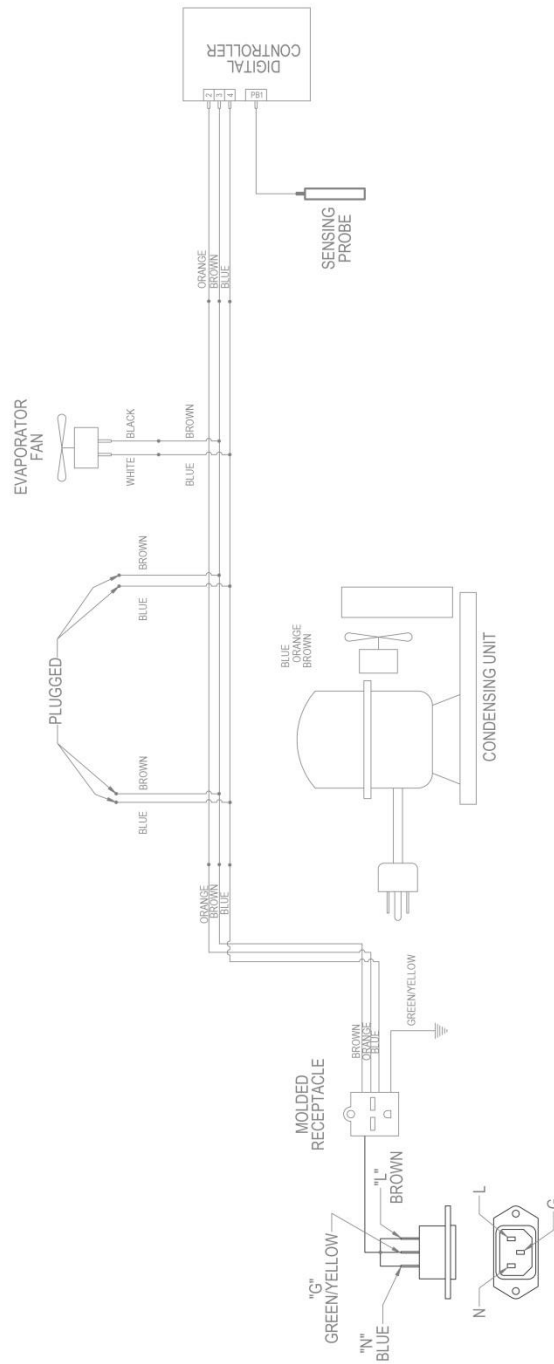

Figure 7-8. DDS, DDC Wiring Diagram

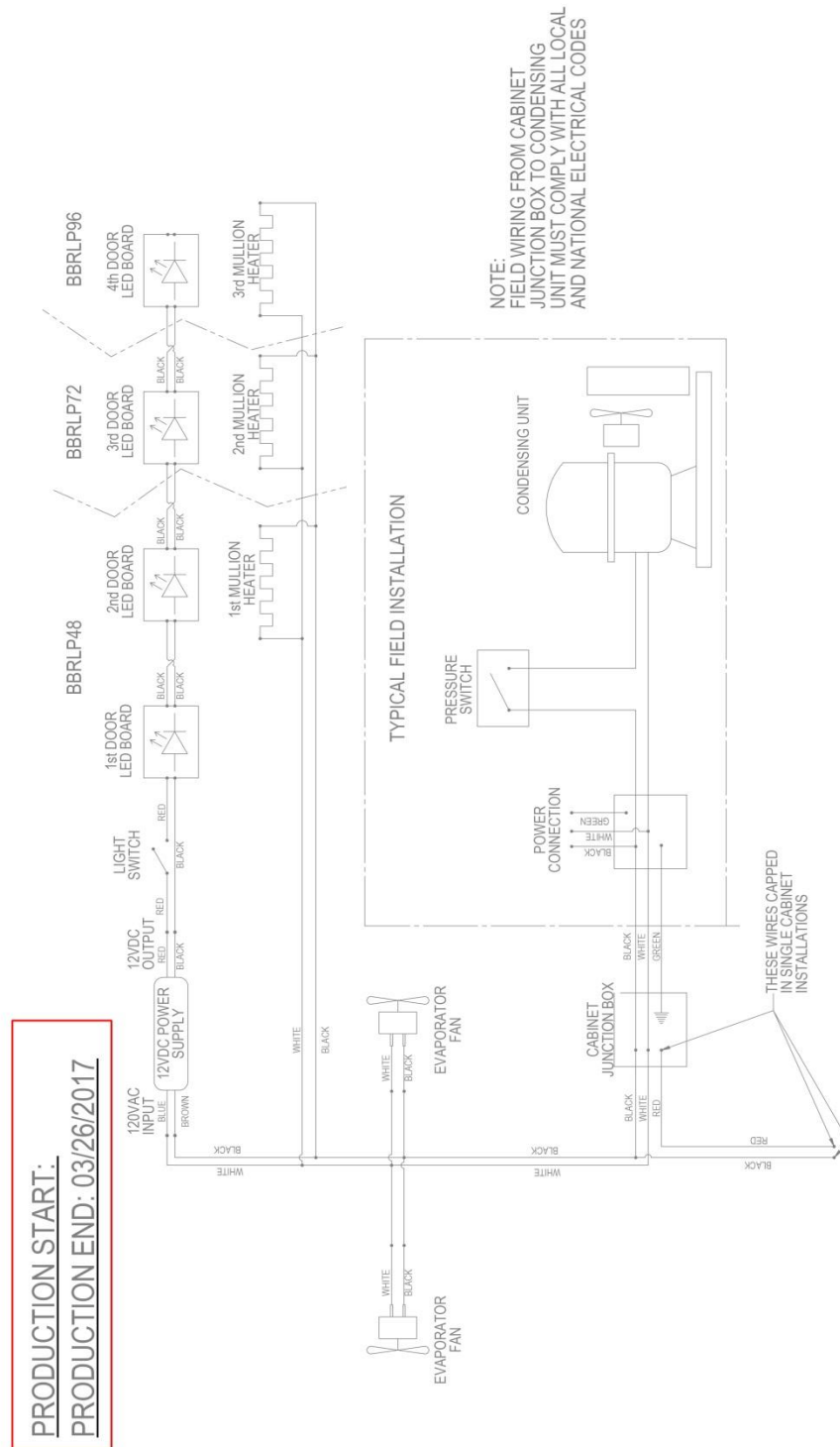

Figure 7-9. BBRLP48, BBRLP72, BBRLP96 Wiring Diagram.

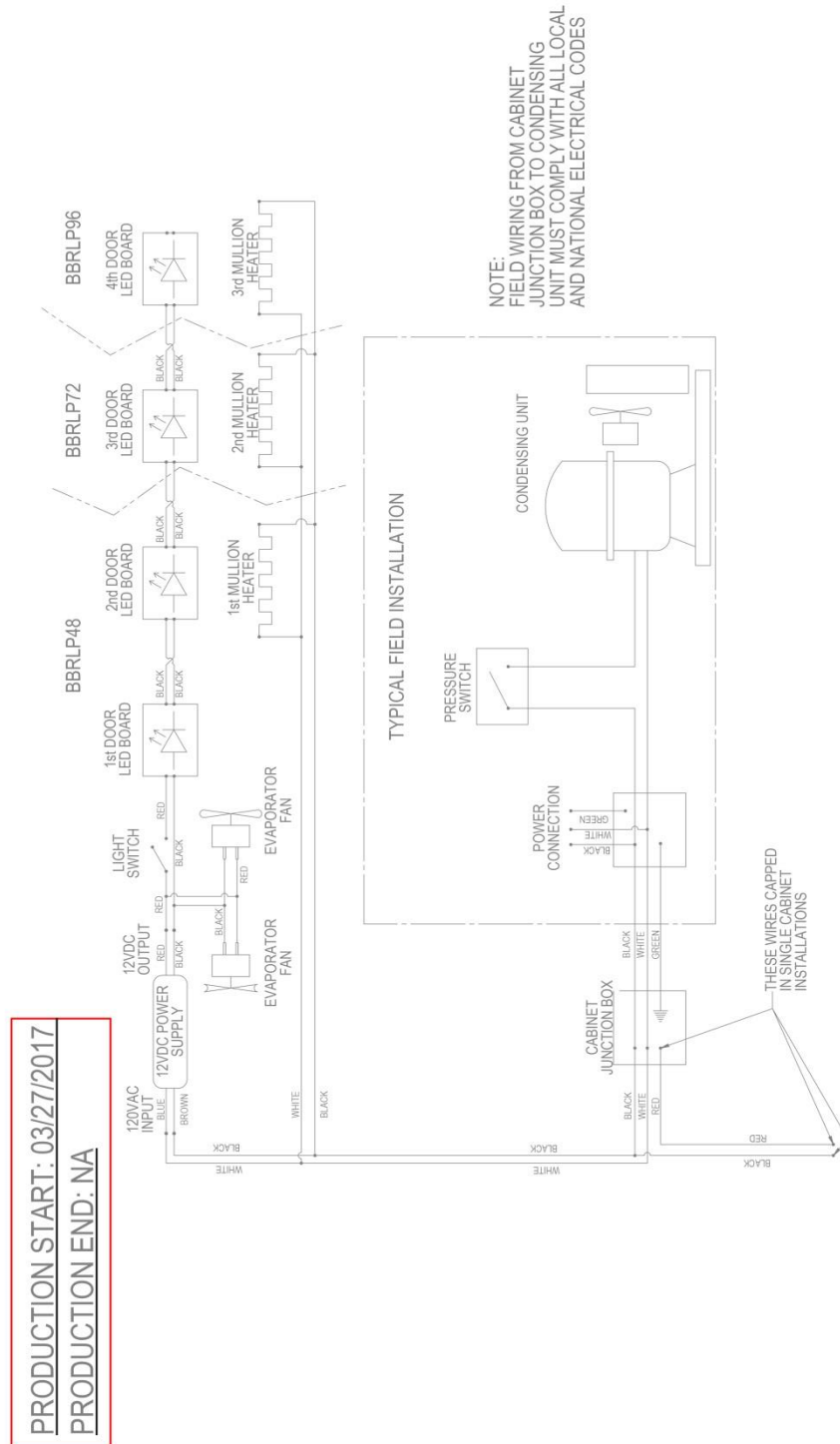





Figure 7-9. BBRLP48, BBRLP72, BBRLP96 Wiring Diagram



### 7.3 Load Operation Modes

Table 7-2. Load Operation Modes

LOAD	COOLING MODE	OFF MODE	DEFROST MODE
Compressor	Energized	De-Energized	De-Energized
Condenser Fan	Energized	De-Energized	De-Energized
Evaporator Fan	Energized	Energized	Energized
Mullion Heaters	Energized	Energized	Energized
Eliwell Controller Display		No icon illuminated	
Dixell Controller Display		No icon illuminated	
Inverter (if applicable)	Energized	De-Energized	De-Energized

### 7.4 Electronic Controller

**Note:** The digital readout is monitoring true air temperature, not product temperature.

Be sure to allow 24 hours between temperature controller adjustments.

Table 7-3. Controller Where-Used Table

Controller Type	Build Date
Eliwell	Beginning 9/19/2016
Dixell	4/1/2013 to 9/16/2016

#### Eliwell Controller



Press and release controller set key to display 'Machine Status' menu and 'SET' label.

Press and release the set key again to display the current set point.

Refer to Table 7-4 for factory set point.

To adjust controller set point, press up and down arrow keys within 15 seconds.

Press set key once for controller to memorize new set point.

#### Dixell Controller



To view set point, press and release SET key.

Refer to Table 7-4 for factory set point.

To change set point value, press and hold SET key for at least 2 seconds. The set point value will be displayed along with a blinking "°C" or "°F" LED.

Release the SET key and then use up or down arrows within 10 seconds to change the set point.

The new set point will be memorized by either pressing SET key again or by waiting 10 seconds.



## 7.5 Factory Set Point

Table 7-4. Factory Temperature Settings

Model	Refrigerator °F (°C)	White Wine °F (°C)	Red Wine °F (°C)
BBS, BBSN PTS, DZS SDBS, SDPS BBSLP, DDC DDS	36 (2.2)	45 (7.2)	60 (15.5)

### 7.5.1 Dixell Controller: Reset Factory Parameter Settings

- Contact Perlick.

### 7.5.2 Eliwell Controller: Reset Factory Parameter Settings

## LOADING DEFAULT APPLICATIONS

The procedure used to load one of the default applications is:

- When the instrument switches on, press and hold the **set** key: the label **AP1** will appear;
- Scroll through the various applications (**AP1-AP2-AP3**) using the **▲** **▼** keys;
- Select the desired application using the **set** key (**AP3** in the example) or cancel the procedure by pressing the **⏻** key or alternatively wait for the timeout;
- If the operation is successful, the display will show **y**, otherwise **n** will appear;
- After a few seconds the instrument will return to the main display.



## LOADING APPLICATIONS WHEN EXITING STAND-BY MODE

The procedure for loading one of the preset applications when exiting stand-by mode is:



- Set the instrument in stand-by mode by pressing the **⏻** button for time **H02**;
- Exit stand-by mode by pressing the **⏻** button for time H02;
- Within 10 seconds of exiting stand-by mode, press the **⏻** button for time **H02: AP1** label will appear;
- Scroll through the various applications (**AP1-AP2-AP3**) using the **▲** **▼** keys;
- Select the desired application using the **set** key (**AP3** in the example) or cancel the procedure by pressing the **⏻** key or alternatively wait for the timeout;
- If the operation is successful, the display will show **y**, otherwise **n** will appear;
- After a few seconds the instrument will return to the main display.

Single Zone Models	Dual Zone Models: Zone 1 Control	Dual Zone Models: Zone 2 Control
AP1 = Refrigerator settings (36°F)	AP1 = Refrigerator settings (36°F)	AP1 = Not Used
AP2 = White Wine settings (45°F)	AP2 = White Wine settings (45°F)	AP2 = White Wine settings (45°F)
AP3 = Red Wine settings (60°F)	AP3 = Not Used	AP3 = Red Wine settings (60°F)

### 7.5.3 Replacing Control Module

#### 7.5.3.1 Removing Dixell Controller

**Tools required**

**STEP 1.**

Remove the grille by removing 3 Phillips head screws, one at the top center and two at the bottom edge.

**STEP 2.**

Remove 2 screws holding control cradle to unit.



**STEP 3.**

Remove clips holding the controller to the cradle. Control cradle will slide freely from the controller.

**CAUTION**

Do not attempt to reuse the old wiring harness.

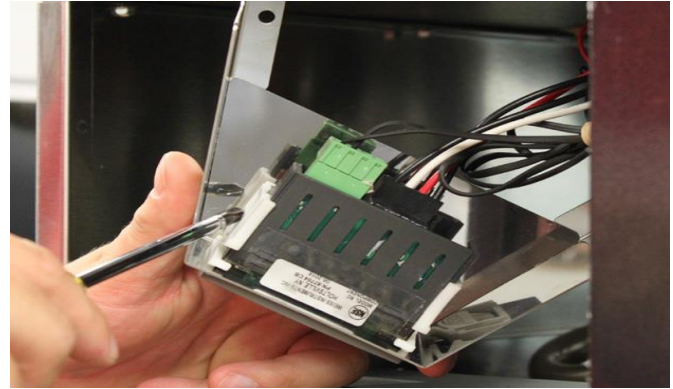

**STEP 4.**

Cut 2 zip ties holding wire harness to top of the refrigeration module.

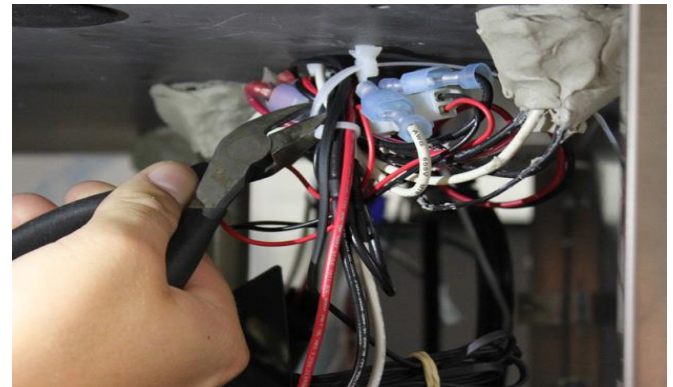

**STEP 5.**

Disconnect evaporator fan wire leads from the main wiring harness.

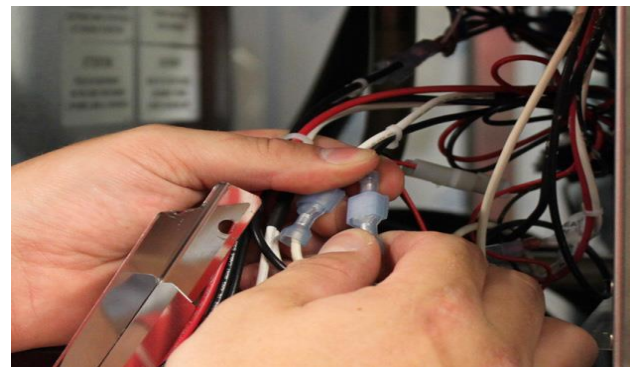

**STEP 6.**

Disconnect mullion heater wire leads from the main wiring harness.

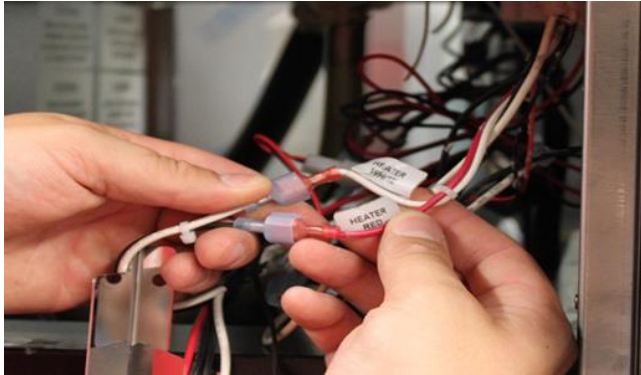

**STEP 7.**

Disconnect DC driver leads from the main wiring harness.

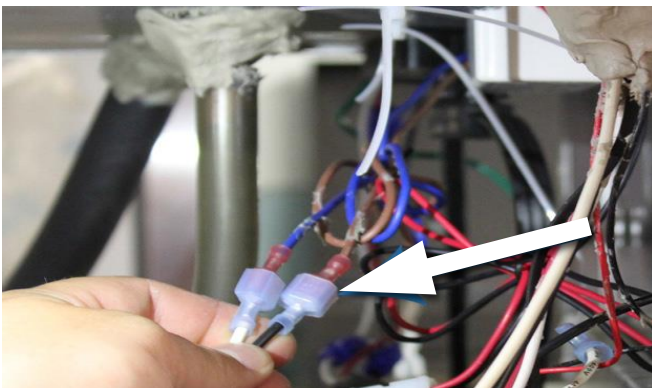

**STEP 8.**

Remove main wiring harness by disconnecting Molex connector from molded receptacle.

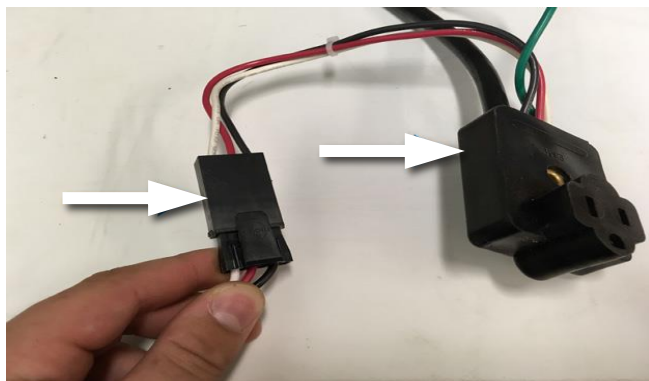

**STEP 9.**

Remove green probe connector from controller.

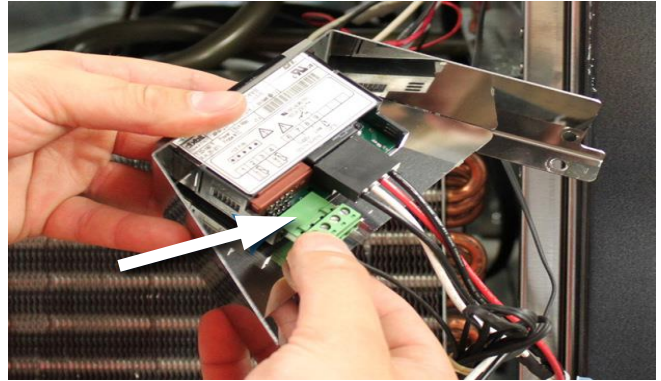

**STEP 10.**

Remove controller assembly from the unit.

**STEP 11.**

Remove shelving and pilaster from the unit wall.

**STEP 12.**

Remove evaporator fan panel. See Figure 6-8.

**STEP 13.**

Remove screw holding probe bracket to the unit.

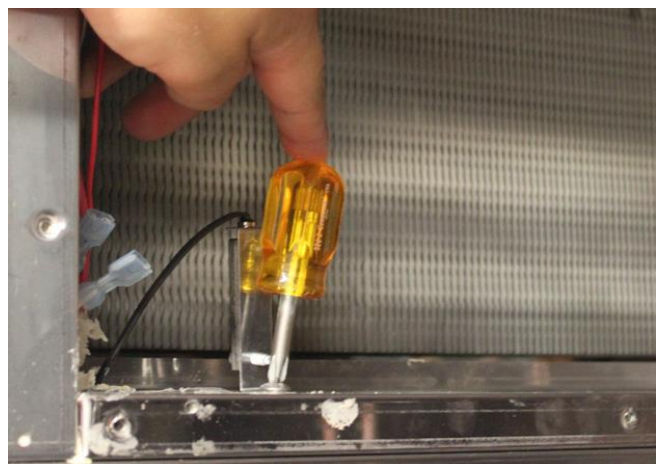



**STEP 14.**

Remove screw holding probe "mass" to the probe bracket and remove the probe.



**STEP 15.**

Remove sealing compound from top of wire pass-through (inside evaporator box).

**STEP 16.**

Remove sealing compound from bottom of wire pass-through (inside condenser compartment).

**STEP 17.**

Pull probe out through the bottom of the evaporator box.

**STEP 18.**

Discard Dixell probe assembly.

7.5.3.2 Installing Eliwell Controller

**Tools required**

	Sealing Compound Cable ties
--	--------------------------------

**STEP 1.**

Feed Eliwell probe through the bottom of the evaporator box.

**STEP 2.**

Attach probe and mass onto probe bracket with screw.

**STEP 3.**

Use pliers if needed to secure probe notch to sheet metal probe bracket. See Figure 7-2.

Crimp gently to avoid damaging the probe. The notch in the probe body should fit into the bracket slot to encapsulate the probe into stainless steel sleeve.



Figure 7-2. Attach Probe to Bracket

**STEP 4.**

Attach the bracket/probe assembly to the bottom of the evaporator box with screw.

**STEP 5.**

Replace sealing compound at top of wire pass-through (inside evaporator box). Verify a complete seal around the wire harness and pass-through hole.

**STEP 6.**

Replace the evaporator fan panel.

**STEP 7.**

Replace the sealing compound at bottom of wire pass-through (inside condenser compartment). Verify a complete seal around the wire harness and pass-through hole.

**STEP 8.**

Reverse this instruction to connect the replacement wire harness/controller/bracket assembly.



### 7.5.4 Temperature Probe

- Each refrigerated zone has one 10K ohm NTC probe, which senses compartment temperature. Sensing probe is located behind evaporator fan panel.

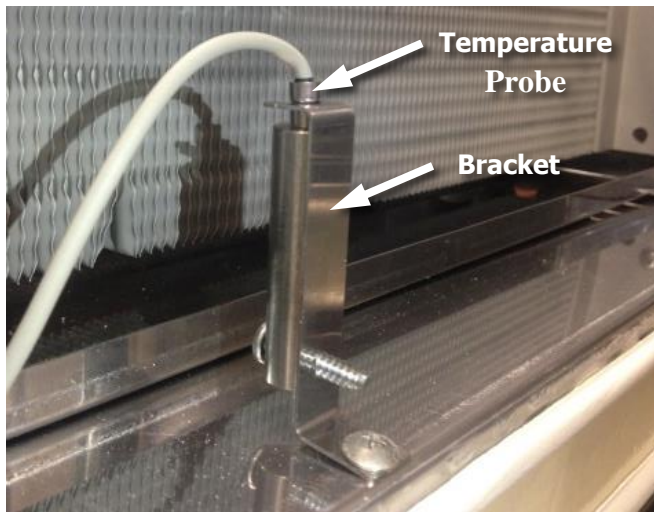

Figure 7-3. Temperature Probe and Bracket

- See Table 7-5 for temperature to resistance values when troubleshooting probe or temperature issues.

Table 7-5. Temperature – Resistance Values

TEMPERATURE (°C)	TEMPERATURE (°F)	RESISTANCE (OHMS)
-30	-22	111300
-25	-13	86430
-20	-4	67770
-15	5	53410
-10	14	42470
-5	23	33900
0	32	27280
5	41	22050
10	50	17960
15	59	14690
20	68	12090
25	77	10000
30	86	8313
35	95	6940
40	104	5827

TEMPERATURE (°C)	TEMPERATURE (°F)	RESISTANCE (OHMS)
45	113	4911
50	122	4160
55	131	3536

- To replace temperature probe, refer to section 7.5.3.

## 7.6 LED Lighting

### 7.6.1 Replace LED Light Strip

**⚠ DANGER**

**ELECTROCUTION HAZARD!!**  
**Never attempt to repair or perform maintenance on unit until main electrical power to the unit has been disconnected!**

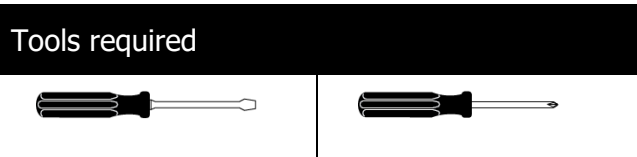

#### STEP 1.

Open door or remove upper drawer. See Figure 8-13.

#### STEP 2.

Using a flat blade screwdriver, carefully pry off the lens cover. See Figure 7-4.

#### STEP 3.

Remove two screws securing LED light to housing.

#### STEP 4.

Unplug the LED from the wiring harness.

#### STEP 5.

Plug new LED into harness and secure to housing using screws removed in step 2.

#### STEP 6.

Snap LED cover into place.

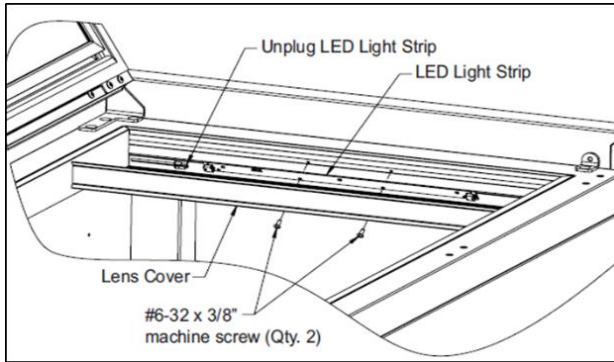
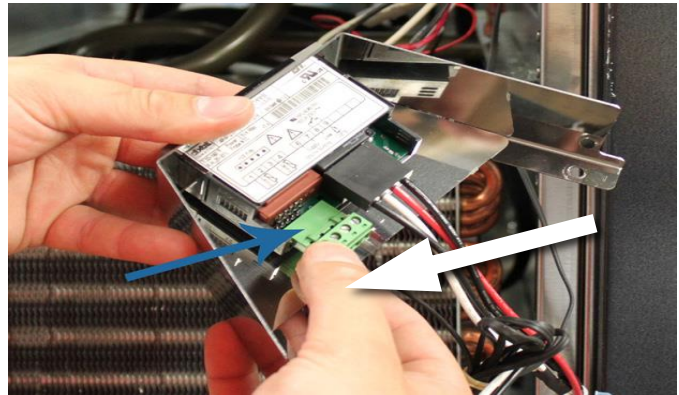

Figure 7-4. Interior LED Light

If not within range printed on the part, replace the part.

**STEP 3.**

Disconnect DC driver leads from the main wiring harness.



**STEP 4.**

Use reverse procedure to install replacement DC driver/Inverter.

**7.7 Replace DC Driver/Inverter**

**STEP 1.**

Locate DC Driver/Inverter on ceiling of refrigeration compartment.



**STEP 2.**

Check voltage.



## 8.0 Service Instructions - Doors, Drawers, and Shelving

### 8.1 Proper Door and Drawer Usage

**Note:** Improper use of doors and drawers can allow extra heat into unit causing extended compressor run times.



- Ensure door or drawers are closed completely and are not left open for a long duration of time. The door can bounce back open slightly and appear closed.
- Ensure the unit is level.
- Ensure doors and drawers are sealing properly when closed.
- No door adjustments should be necessary unless there is major structural damage to cabinet.

### 8.2 Reverse Door Swing

**Note:** Changing door swing direction is not advisable if door is not equipped with full length handle. Doing so may result in an undesirable handle position.

Table 8-1. Door Hinges

HINGE KIT - PART NUMBER	DESCRIPTION
67439R	Right Hinging
67439L	Left Hinging

Tools required	
	Perlick Hinge Kit 
	

#### STEP 1.

Support the door in the open position as shown in Figure 8-1. Remove the hinge pin.

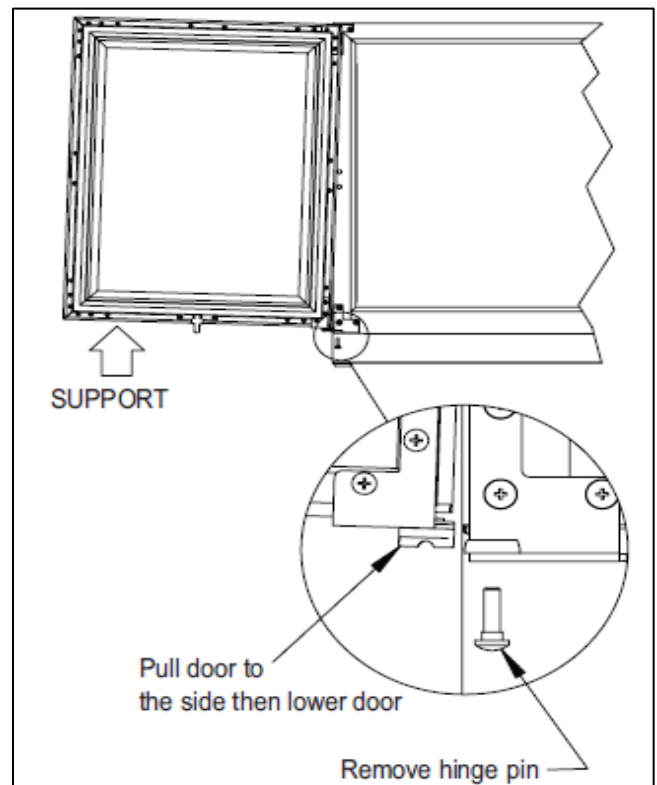

Figure 8-1. Door Removal

#### STEP 2.

Pull door to the side and then lower the door.

**STEP 3.**

Remove top and bottom hinge brackets. Retain screws for later use. See Figure 8-2.

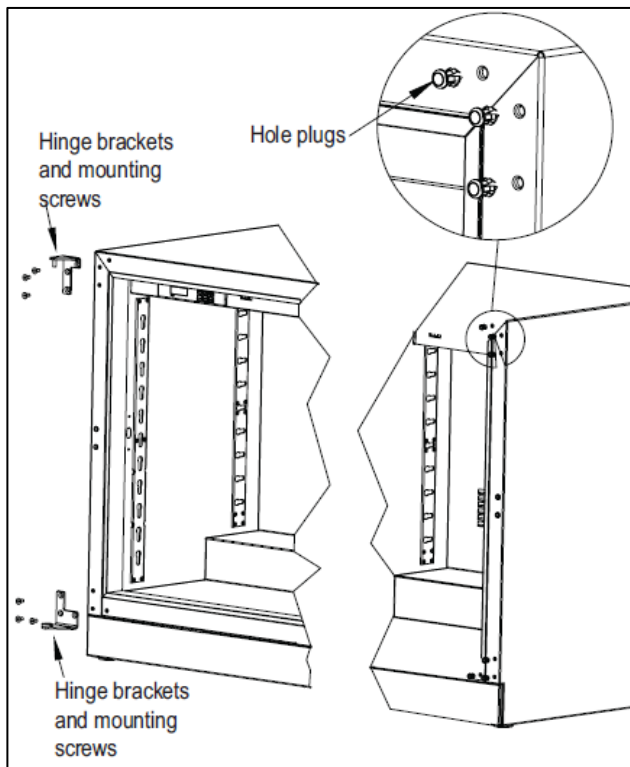

Figure 8-2. Hinge Removal

**STEP 4.**

Remove hole plugs from top and bottom hinge bracket mounting holes. See Figure 8-2.

Place plugs in holes on opposite side made vacant by removing hinges in step 3.

**STEP 5.**

Using screws removed in step 3, install top and bottom hinge brackets from kit. See Figure 8-3.

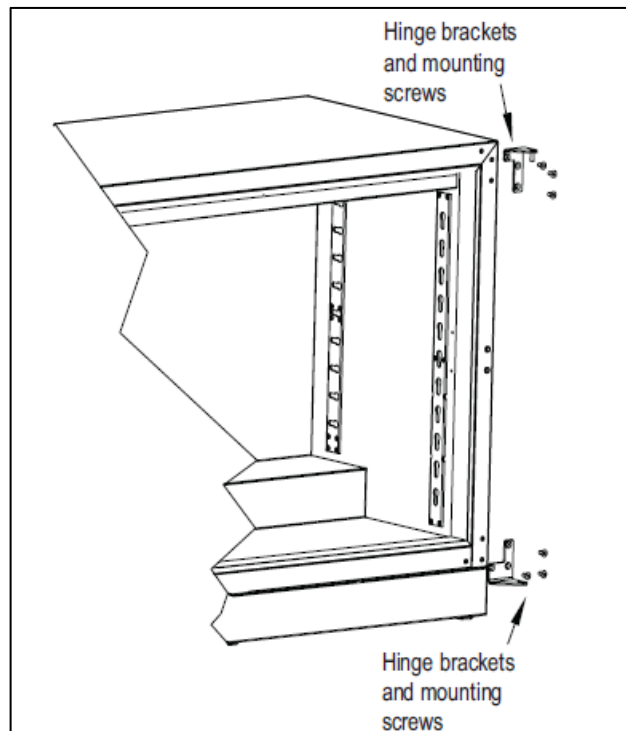

Figure 8-3. Hinge Installation

**STEP 6.**

Remove top and bottom hinge brackets from door (Figure 8-4). Retain screws for later use.

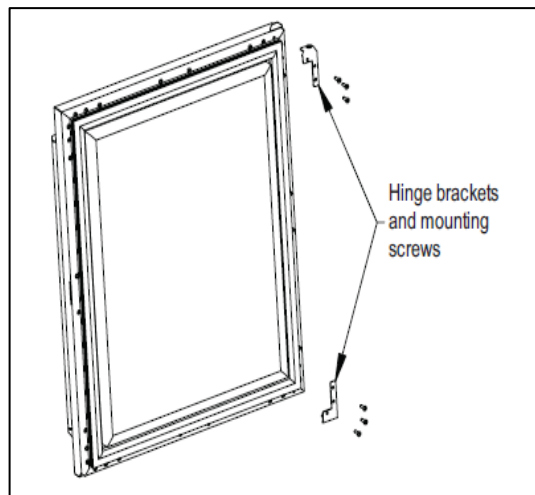

Figure 8-4. Door Brackets



**STEP 7.**

Remove front panel from door assembly by removing inner mounting screws (4 per side) from perimeter of door assembly. See Figure 8-5.

Rotate front panel 180° top to bottom. Reattach using same screw and mounting holes.

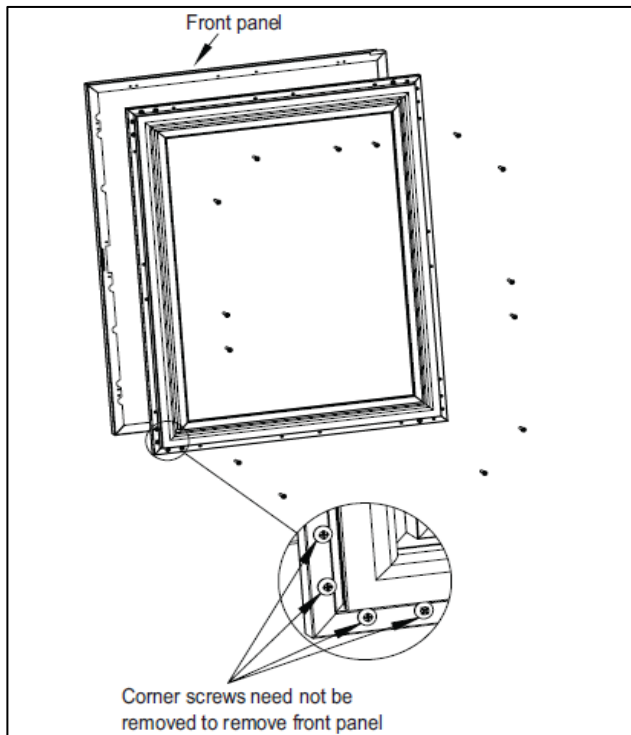

Figure 8-5. Removing Front Panel

**STEP 8.**

Insert bearing into door top hinge bracket. See Figure 8-6.

**STEP 9.**

Insert V-block into door bottom hinge bracket and attach with e-clip. See Figure 8-6. Note the orientation of V-block.

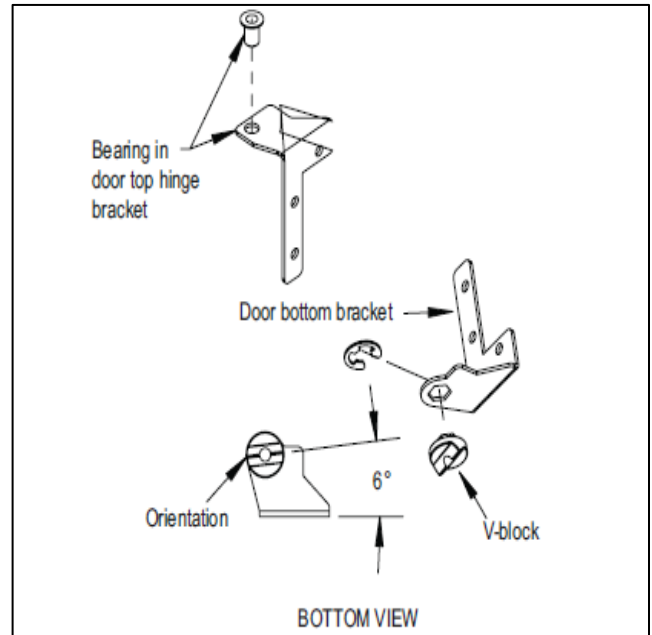

Figure 8-6. Bearing and V-Block

**STEP 10.**

Attach top and bottom door hinges using screws removed in STEP 6. See Figure 8-7.

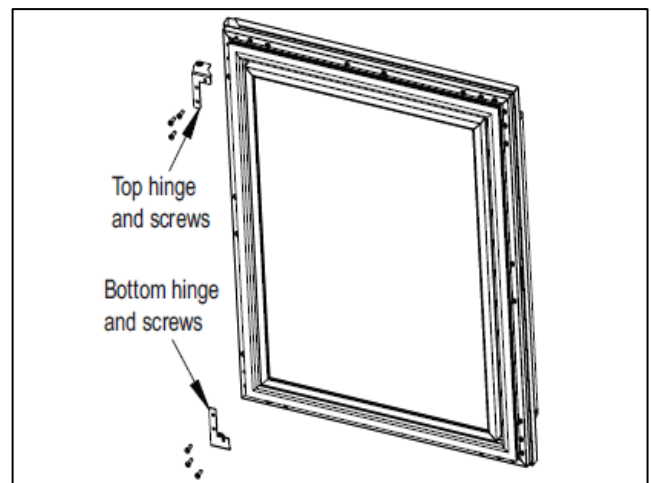

Figure 8-7. Door Hinges

**STEP 11.**

Place lower V-block into lower cabinet hinge with notch parallel to cabinet. See Figure 8-8.

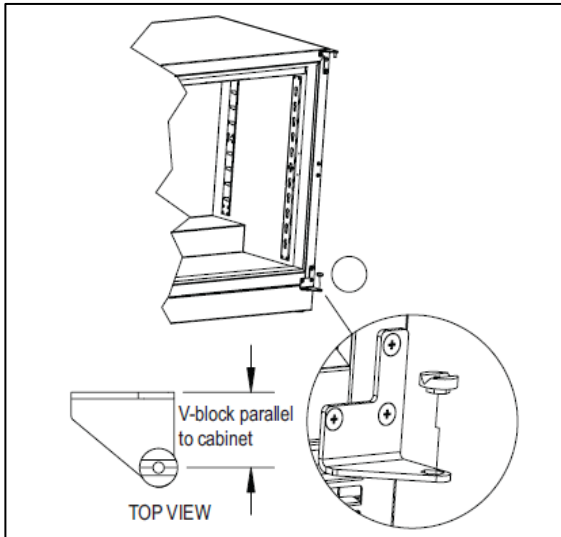

Figure 8-8. Installing V-Block

**STEP 12.**

Lift door assembly and insert top pin into bearing. Move door toward cabinet and align V-blocks. See Figure 8-8 and Figure 8-9.

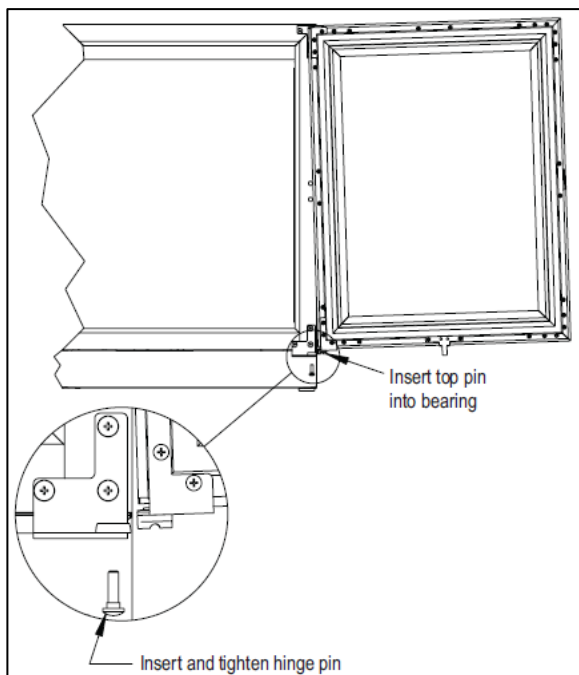

Figure 8-9. Installing Door

**STEP 13.**

Insert and tighten lower hinge pin to complete assembly.

**8.3 Replace Door Hinge**

See Section 8.2 for hinge replacement instructions.

**8.4 Sliding Door Models**

**8.4.1 Removing/Installing Sliding Doors**

**STEP 1.**

To remove sliding door, simply grasp door on each side and lift up off bottom track, then tilt outwards and pull down to remove from upper track.

**STEP 2.**

To reinstall sliding door, place door in upper track. Be sure to engage bracket. See Figure 8-10.

Lift door up into track and place into bottom track.

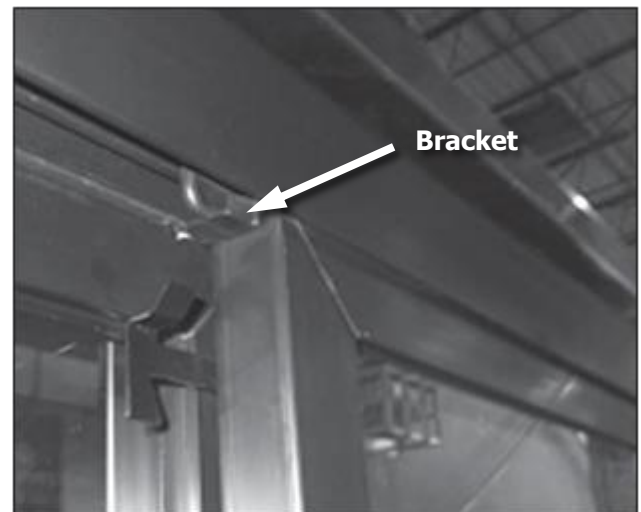

Figure 8-10. Removing/Installing Sliding Door



### 8.4.2 Adjusting Door Spring Tension

**Tools required**

Tension spring is in upper track of each door.

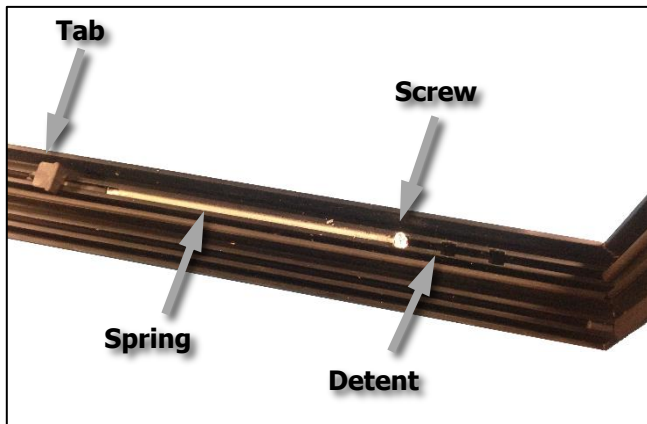

Figure 8-11. Door Track

To increase or decrease spring tension:

- Remove Phillips screw
- Position bracket in one of three detents
- Reinstall screw

Detent farthest from left provides the least amount of tension.

Units are shipped from factory with springs set at the weakest setting.

### 8.4.3 Torpedo Spring Adjustment

**Tools required**

**STEP 1.**

Remove doors.

**STEP 2.**

Remove screw.

**STEP 3.**

Pull up spring and attached black tab.

**STEP 4.**

Feed into next notch to tighten/loosen.

**STEP 5.**

Tighten screw.

## 8.5 Drawer & Shelf Slides

### 8.5.1 Shelving Adjustment

**CAUTION**

Completely empty shelf or drawer before removing.

**STEP 1.**

Open door and slide shelf out.

**STEP 2.**

Press locking mechanism. Tilt shelf and remove from unit



Figure 8-12. Shelf Locking Mechanism

**STEP 3.**

Reposition each bracket separately. Grasp middle of bracket, pull front end up and out, then forward to remove.

**STEP 4.**

Place brackets at desired location and reinstall shelf(s).



### 8.5.2 Drawer Divider Adjustment

#### ⚠ CAUTION

Completely empty shelf or drawer before removing.

#### STEP 1.

Lift divider straight up and move to desired position, engaging tabs in holes. Make sure divider tabs engage corresponding holes on both sides.

### 8.5.3 Cleaning/Lubricating Drawer Extenders

#### ⚠ CAUTION

Completely empty shelf or drawer before removing.

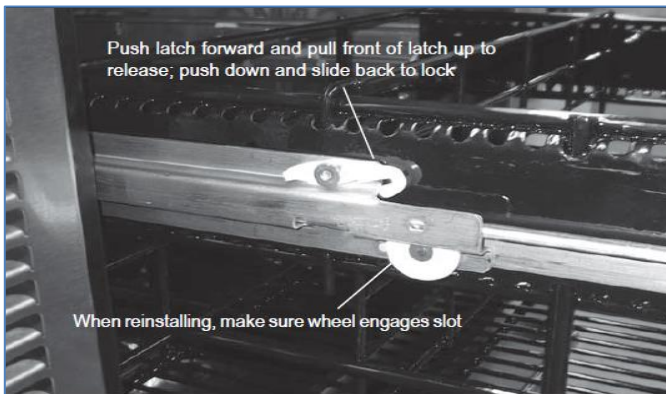

Figure 8-13. Removing/Installing Drawer

#### STEP 1.

Drawer must be removed to clean or lubricate the extenders.

#### STEP 2.

Pull the drawer out to its furthest position. Locate the latch in the middle of both extenders. Push each latch forward and lift front of latch up (unlocked position), then lift the front of the drawer and pull out.

#### STEP 3.

Use a food grade lubricant to lubricate the drawer extenders.

#### STEP 4.

Place drawer on to the extenders, making sure wheels engage the slots on each side.

#### STEP 5.

Push drawer all the way in, then pull drawer out and push the latch down and back to engage. Make sure front of latches are fully down and back, engaging the extenders.

### 8.6 Replace Door & Drawer Gasket

#### STEP 1.

Remove gasket by lifting at one corner and pulling gasket away from door. Work around the door until gasket is free.

#### STEP 2.



To replace, start at one corner and press firmly to seat the gasket dart in the channel of the door frame. Listen/feel for a click to indicate the dart is completely seated.

#### STEP 3.

Finish by going around the gasket once more to feel for any gaps and to ensure the gasket is flat and fully seated.

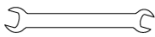

### 8.7 Replace Door Handle

Tools required	
 3/8"	

#### STEP 1.

Remove door gasket. See Section 8.6.

#### STEP 2.

Remove 16 screws underneath door gasket that hold door overlay panel to door frame.

#### STEP 3.

Remove 3 screws from each door hinge where it is attached to door frame.

#### STEP 4.

Separate door overlay panel from door frame.

#### STEP 5.

Door handle can now be removed, 4 X 3/8" hex head bolts.

#### STEP 6.

Reverse these steps to replace door hinges, overlay panel, and gasket.

### 8.8 Locks

Gain access to back side of the lock by following directions to remove door handle, Section 8.7.

Note position of door lock strike and reassemble in the same orientation.

### 8.9 Custom Overlay Panels

Tools required	
	

Remove front panel from door assembly by removing inner mounting screws (4 per side) from perimeter of door assembly. See Figure 8-14.

Reattach **custom** overlay panel using same screw and mounting holes.

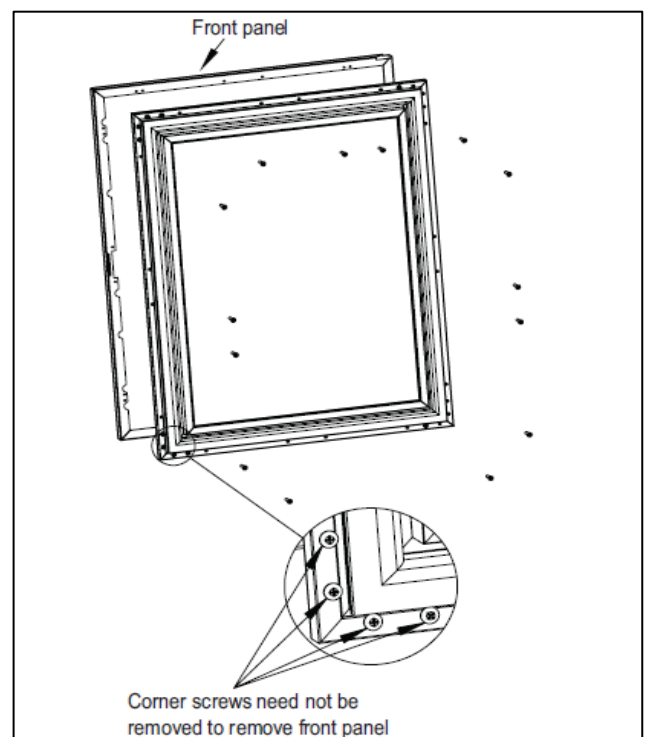

Figure 8-14. Custom Panel



## 9.0 Replacement Parts

For parts ordering call (844) 411-8050.

### 9.1 Refrigeration Module (BBS, BBSN, PTS, SDBS, SDPS, DDS, DDC Model Series)

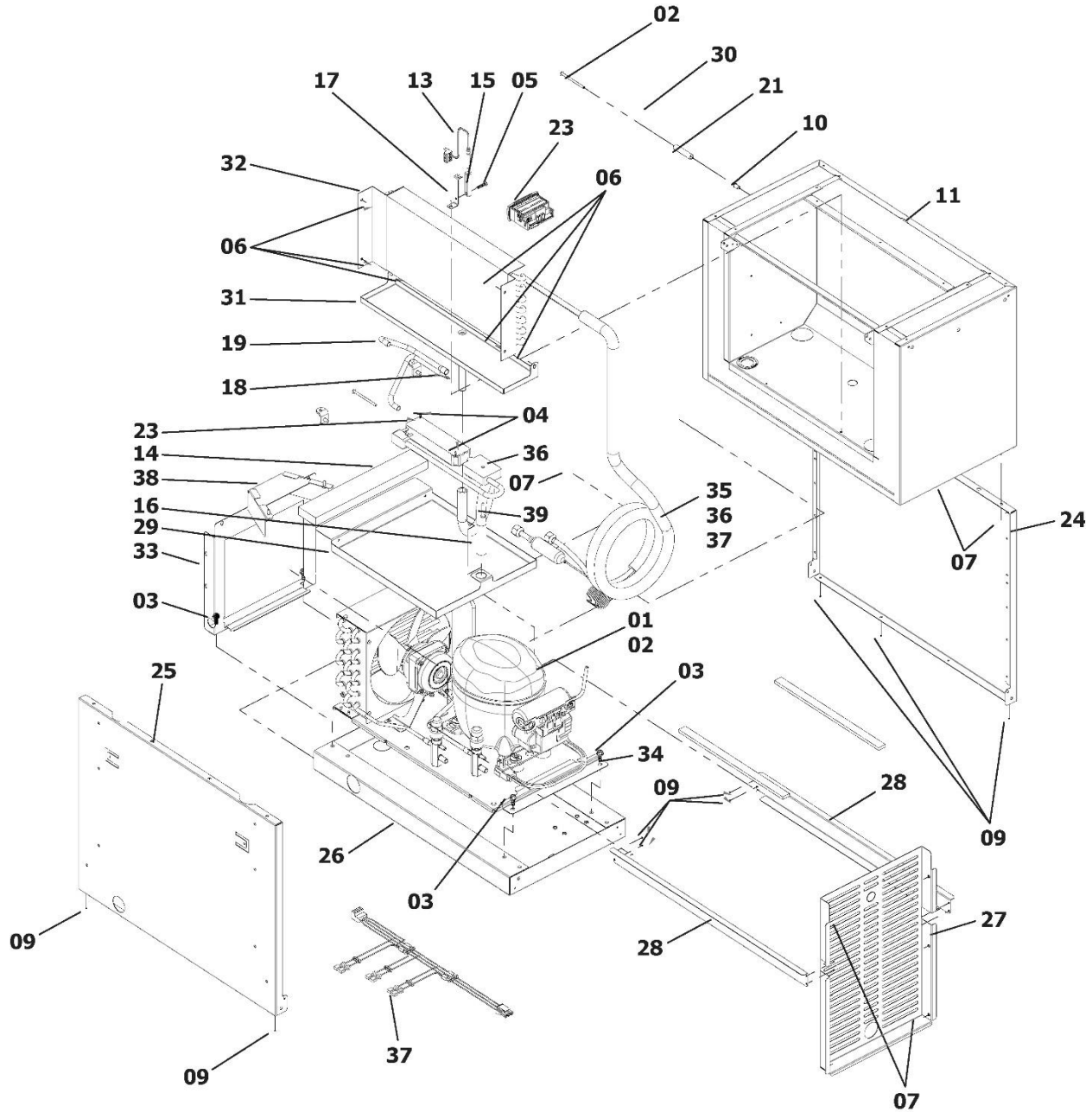



<b>BBS, BBSN, PTS, SDBS, SDPS, DDS, DDC MODELS</b>				
<b>ITEM NUMBER</b>	<b>DESCRIPTION</b>	<b>1-DOOR QTY.</b>	<b>2-DOOR QTY.</b>	<b>3&amp;4-DOOR QTY.</b>
01	Condensing Unit, 1/5 H.P. 115V, BOM #515301064	1	-	-
01	Condensing Unit, 1/4 H.P., 115V, BOM #515301063	-	1	-
01	Condensing Unit, 1/3 H.P. 115V, BOM #515301062	-	-	1
02	Screw, Phillips Truss Head Machine	1	1	-
03	Screw, Thread Cutter, Hex Washer Head	4	4	4
04	Screw, Phillips Truss Head Sheet Metal	2	2	2
05	Screw, Phillips Pan Head Sheet Metal	1	1	1
06	Screw, Phillips Head	9	9	4
07	Screw, Sheet Metal	20	20	20
08	Screw	2	2	2
09	Rivet, Pop	20	20	20
10	Rivnut, Insert	1	1	-
11	Low Side Foamed Assembly	1	1	1
12	Gasket, .25"	2	2	2
13	Probe, Temperature	1	1	1
14	Foam, Divider	1	1	1
15	Sleeve, Sensor Insulating	1	1	1
16	Tube, Drain, Evaporator Pan to Condenser Pan	1	1	1
17	Bracket, Temperature Sensor	1	1	1
19	Tube, Evaporator	1	1	-
18	Tube, Crimped Evaporator	1	1	-
20	Bracket, Top Pull Down	2	2	2
21	Standoff, Grille	1	1	1
22	LED Driver	1	1	1
23	Controller	1	1	1
24	Panel, Outer Side, High Side	1	1	1
25	Panel, Inner Side, High Side	1	1	1
26	Base, High Side	1	1	1
27	Cover, Back, High Side	1	1	1
28	Rail, Condensate Pan	2	2	2
29	Pan, Condensate, High Side	1	1	1
30	Grille, Front	1	1	1
31	Pan, Evaporator	1	1	1
32	Evaporator Fin Coil	1	1	1
33	Baffle, Compressor	1	1	1
34	Bracket, Compressor	1	1	1
35	L & S Line, 1 Door	1	-	-
35	L & S Line, 2 Door	-	1	-



<b>BBS, BBSN, PTS, SDBS, SDPS, DDS, DDC MODELS</b>				
<b>ITEM NUMBER</b>	<b>DESCRIPTION</b>	<b>1-DOOR QTY.</b>	<b>2-DOOR QTY.</b>	<b>3&amp;4-DOOR QTY.</b>
35	L & S Line, 3 & 4 Door	-	-	1
36	Power Cord, with Molded Receptacle	1	1	1
37	Wire Harness, Refrigeration Module	1	1	1
38	Bracket, Controller Mounting	1	1	1
39	Screw, Phillips Head	1	1	1
40	Screw, Phillips Head Machine	1	1	1



## 9.2 Refrigeration Module (BBSLP Model Series)

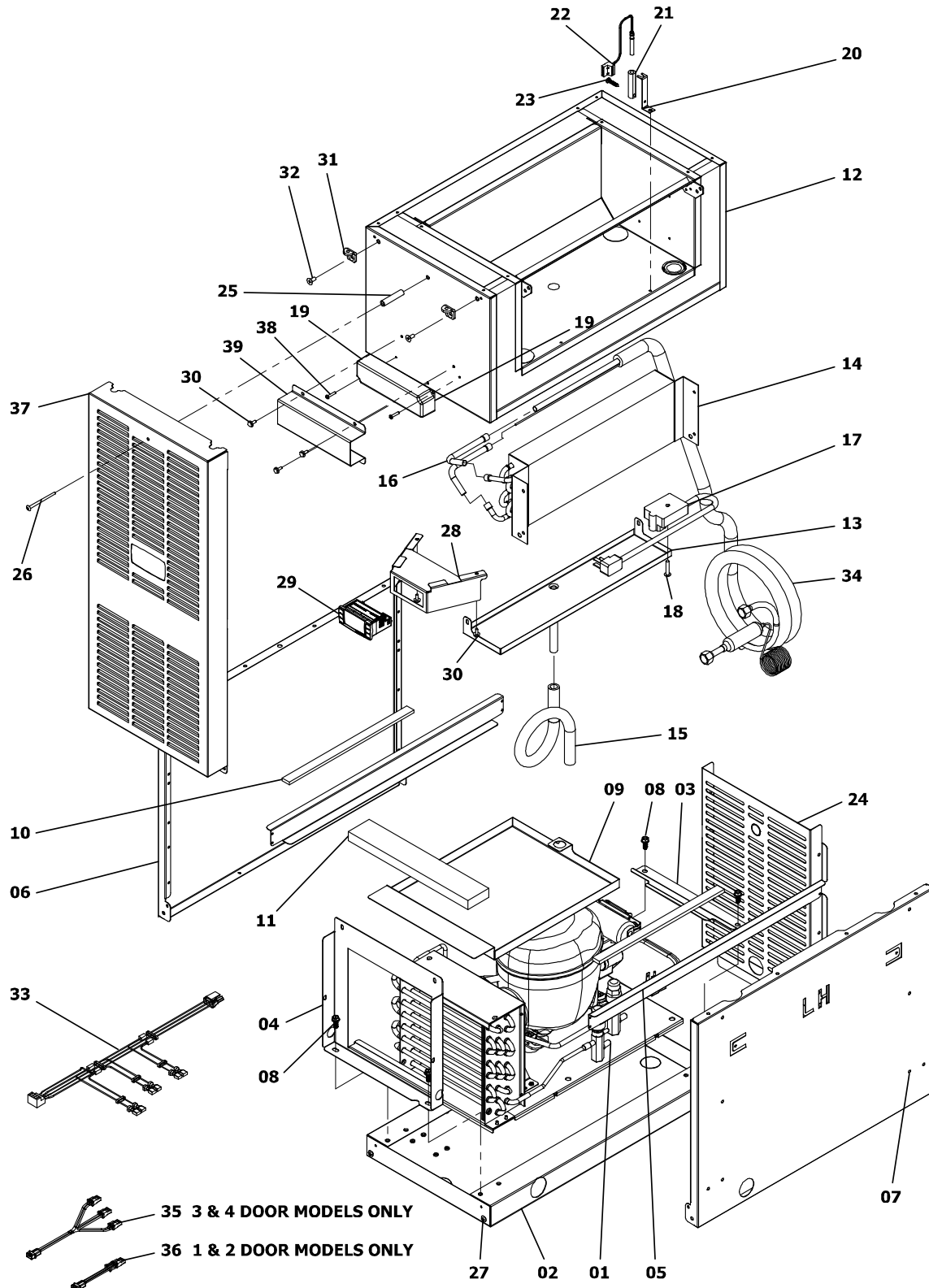



BBSLP MODELS				
ITEM NUMBER	DESCRIPTION	1-DOOR QTY.	2-DOOR QTY.	3&4-DOOR QTY.
01	Condensing Unit, 1/3 HP, 115V	-	-	1
01	Condensing Unit, 1/4 HP 115V	-	1	-
01	Condensing Unit, 1/5 HP, 115V	1	-	-
02	Base, High Side	1	1	1
03	Bracket, Hold Down, Compressor	1	1	1
04	Panel, Baffle, Compressor	1	1	1
05	Rail, Condensate Pan	2	2	2
06	Panel, Outer Side, High Side	1	1	1
07	Panel, Inner Side, High Side	1	1	1
08	Screw, Thread Cutter, 1/4-20 X 5/8	4	4	4
09	Pan, Condensate	1	1	1
10	Gasket	2	2	2
11	Foam Block, Divider Baffle	1	1	1
12	Low Side Shell Assembly	1	1	1
13	Pan, Evaporator, Assembly	1	1	1
14	Coil, Evaporator, 5 X 14 X 1.9	1	1	1
15	Tube, Drain, To Evaporator Pan	1	1	1
16	Tube, Outlet, Evaporator	2	2	2
17	Power Cord with Molded	1	1	1
18	Screw, Sheet Metal, #10 X 1 1/4 Phillips	1	1	1
19	Driver, 12 VDC, 60 Watt, Meanwell Lpv-60-12	1	1	1
20	Bracket, Temp Sensor	1	1	1
21	Sleeve, Sensor Insulating	1	1	1
22	Probe, Temperature, NTC, 10k	1	1	1
23	Screw, Sheet Metal, #10 X 1", Phillips	1	1	1
24	Cover, Back, High Side	1	1	1
25	Standoff, Grille	1	1	1
26	Screw, Machine, #8-32, 2-1/2" Black Zinc Plated		1	
26	Screw, Machine, #8-32, 2-1/2" Zinc Plated	Customer Option		
27	Screw, #10 X 1/2" Phillips Truss Head SMS, #410	4	4	4
28	Controller Mounting Bracket	1	1	1
29	Control	1	1	1
30	Screw, Sheet Metal, #10-16 X 1/2"	5	5	5
31	Top Pull Down Bracket	2	2	2
32	Screw, Tri-lobe, 1/4-20x 1/2" Phillips Flat Head	2	2	2
33	Wire Harness, Condenser Housing	1	1	1
34	L & S Line, 1 Door, Back Bar	1	-	-
34	L & S Line, 2 Door, Back Bar	-	1	-



<b>BBSLP MODELS</b>				
<b>ITEM NUMBER</b>	<b>DESCRIPTION</b>	<b>1-DOOR QTY.</b>	<b>2-DOOR QTY.</b>	<b>3&amp;4-DOOR QTY.</b>
34	L & S Line, 3 & 4 Door, Back Bar	-	-	1
35	Wire Harness, Fan Motors	1	1	1
36	Harness 12VDC Split Male-Female	1	1	1
37	Grille, Front, S.S.		1	
37	Grille, Front, Black Vinyl	Customer Option		
38	Screw, Sheet Metal, #6 X 3/4", Phillips	2	2	2
39	Cover, Dc Driver, Low Ht. Back Bar	1	1	1



### 9.3 Refrigeration Module (DZS60 Model Series)

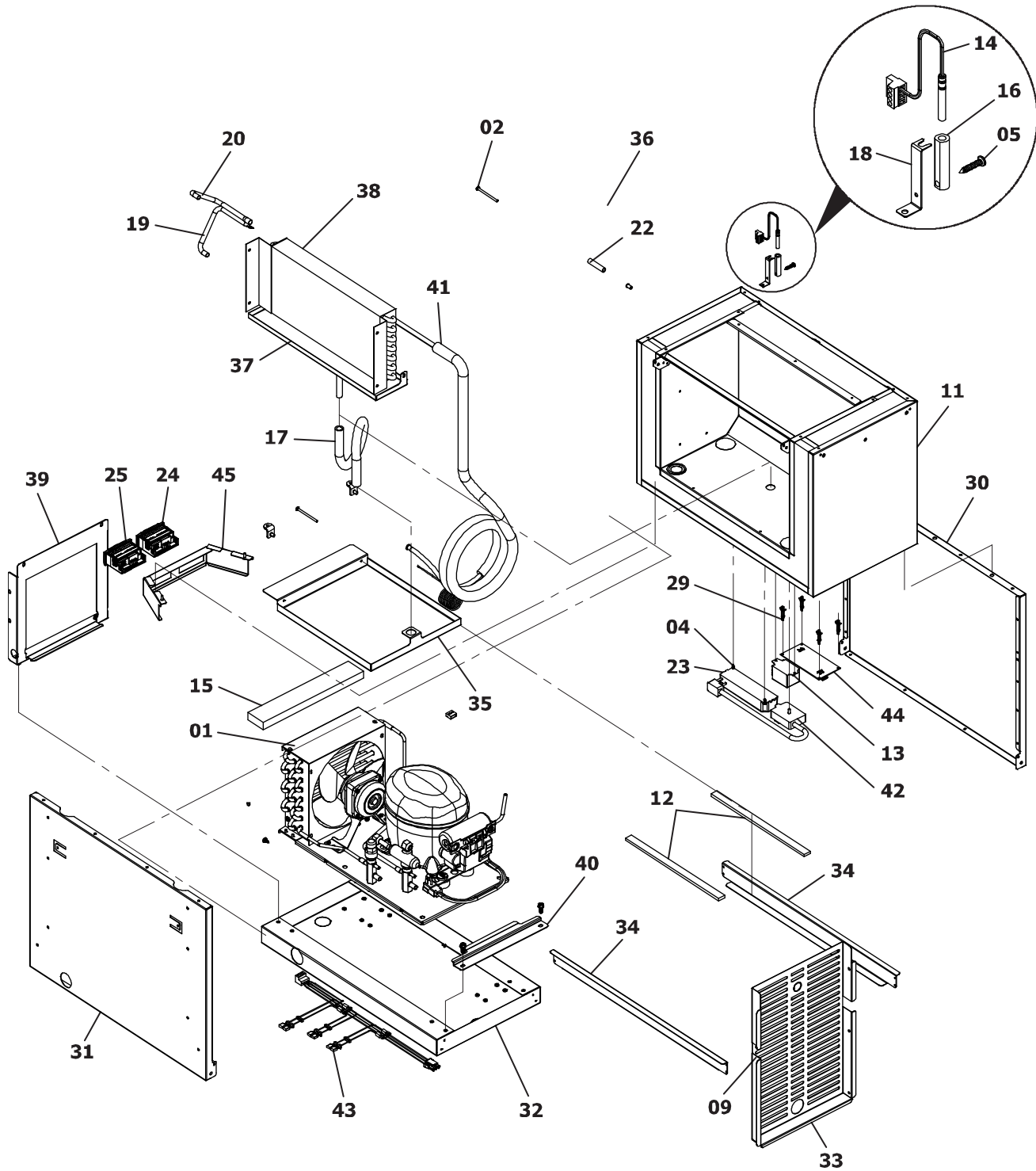



DZS60 MODELS		
ITEM NUMBER	DESCRIPTION	QTY.
01	Condensing Unit, 1/4 H.P., 115V	1
02	Screw, Machine, #8-32 x 2-1/2" Lg, Phillips Truss Head	1
03	Screw, Thread Cutter, 1/4-20 x 5/8 Hex Washer Head, Type 23, Steel	4
04	Screw, Sheet Metal, #6 x 1/2", Type "A", PH Truss Head - Full Contoured, 18-8	2
05	Screw, Sheet Metal, #10 x 1", PH Pan Head, Type "B", Steel, Hardened	1
06	Screw, #10 X 1/2" PH Truss Head SMS #410 S.S., Type "AB"	9
07	Screw, Sheet Metal, #10-16 x 1/2" Hex Flange Grip-Lite, Type "AB"	20
08	Screw, Thread Forming, 1/4-20 X 1/2"	2
09	Rivet, Pop	20
10	Rivnut, Insert	1
11	Low Side Foamed Assembly	1
12	Gasket, Foam .25"	2
13	Relay, Pump, 120VAC Rating	1
14	Probe, Temperature, NTC, 10K Ohm XW60L, 1.8" Nickel Plated	1
15	Foam, Divider, 12"	1
16	Sleeve, Sensor Insulating	1
17	Tube, Drain, Evaporator Pan to Condenser Pan	1
18	Bracket, Temperature Sensor, Back Bar	1
19	Tube, IO, Evaporator, Back Bar (Crimped for Cap Tube)	1
20	Tube, IO, Evaporator, Back Bar	1
21	Top Pull Down Bracket, Back Bar	2
22	Standoff, Grille, Back Ba	1
23	LED Driver	1
24	Control	1
25	Red Display	1
26	Harness 12 VDC Split Male-Female	1
27	Harness, Line Voltage Split	1
28	Harness Stepper Controller Input	1
29	Standoff	4
30	Panel, Outer Side, High Side	1
31	Panel, Inner Side, High Side, Back Bar	1
32	Base, High Side	1
33	Cover, Back, High Side	1
34	Rail, Condensate Pan, Back Bar	2
35	Pan, Condensate, High Side	1
36	Grille, Front, Back Bar	1
37	Pan, Evaporator, Assembly, Back Bar	1
38	Evaporator Fin Coil	1



<b>DZS60 MODELS</b>		
<b>ITEM NUMBER</b>	<b>DESCRIPTION</b>	<b>QTY.</b>
39	Baffle, Compressor	1
40	Bracket, Compressor	1
41	L & S Line, 2 Door Back Bar	1
42	Power Cord with Molded Receptacle, 14/3, Back Bar	1
43	Wire Harness, Refrigeration Module, Back Bar	1
44	Controller Board-Damper, Dual Zone Commercial	1
45	Controller Mounting Bracket	1
46	Screw, #10 X .500 PH TRUSS HEAD	1
47	Plated Screw, Machine, 8-32,2-1/2" Lg Phillip Truss Head, Steel, Black Zinc	1



### 9.4 Refrigeration Module (DZS36 Model Series)

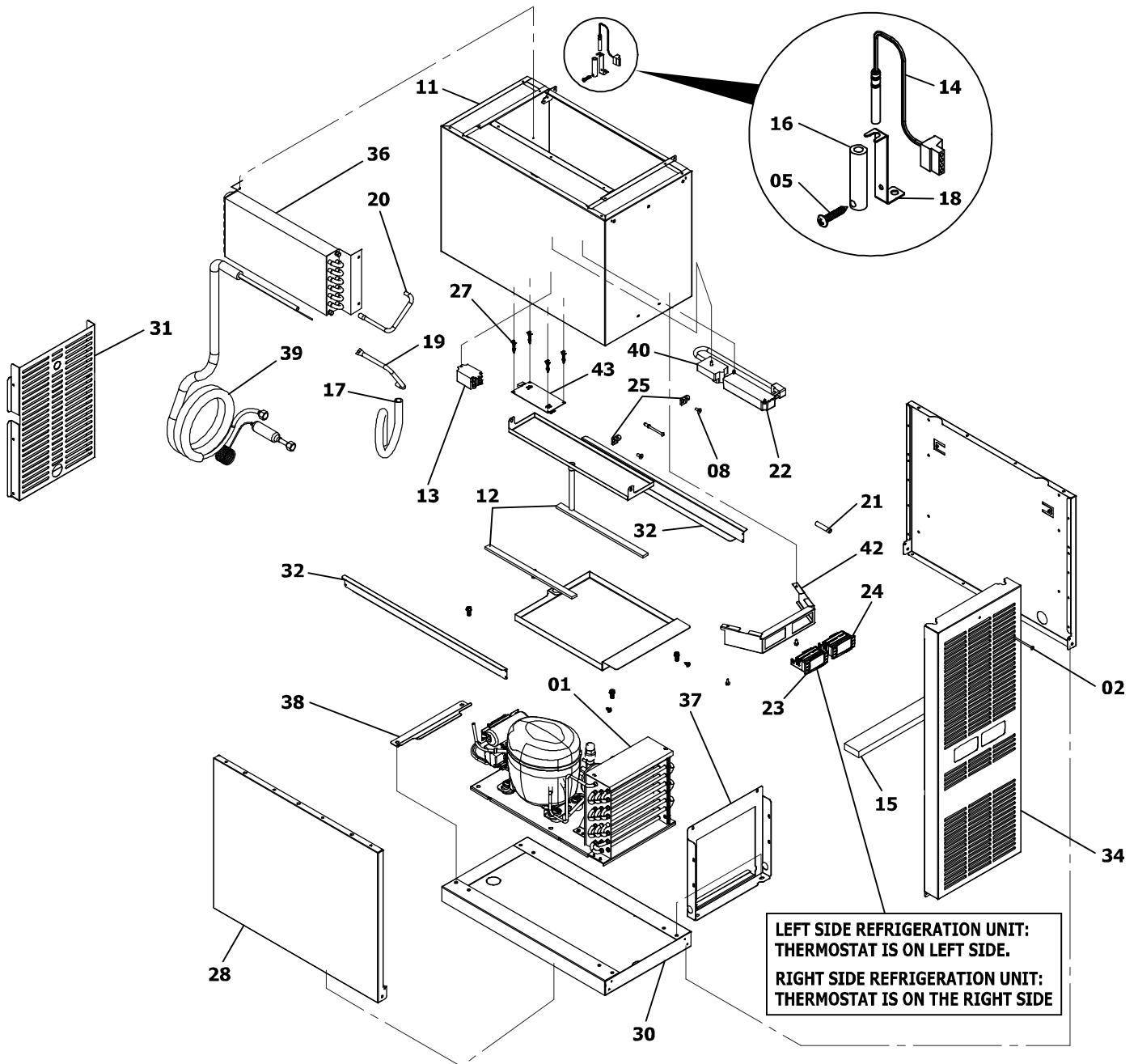

DZS36 MODELS		
ITEM NUMBER	DESCRIPTION	QTY.
01	Condensing Unit, 1/5 H.P. 115V	1
02	Screw, Machine, #8-32 x 2-1/2" Lg, Phillips Truss Head	1



DZS36 MODELS		
ITEM NUMBER	DESCRIPTION	QTY.
03	Screw, Thread Cutter, 1/4-20 x 5/8 Hex Washer Head, Type 23, Steel	4
04	Screw, Sheet Metal, #6 x 1/2", Type "A", PH Truss Head - Full Contoured, 18-8	2
05	Screw, Sheet Metal, #10 x 1", PH Pan Head, Type "B", Steel, Hardened	1
06	Screw, #10 X 1/2" PH Truss Head SMS #410 S.S., Type "AB"	9
07	Screw, Sheet Metal, #10-16 x 1/2" Hex Flange Grip-Lite, Type "AB"	20
08	Screw, Thread Forming, 1/4-20 X 1/2"	2
09	Rivet, Pop, 1/8" Dome Head, S.S., .063" - .125" Grip Range	20
10	Rivnut, Insert, #8-32, Steel, Zinc & Yellow Chromate Plated	1
11	Low Side Foamed Assembly	1
12	Gasket, Low Perm Polyether Foam .25"	2
13	Relay, Pump, 120VAC Rating	1
14	Probe, Temperature, NTC, 10K Ohm XW60L, 1.8" Nickel Plated	1
15	Foam, Divider, 12"	1
16	Sleeve, Sensor Insulating	1
17	Tube, Drain, Evap Pan to Cond Pan	1
18	Bracket, Temperature Sensor, Back Bar	1
19	Tube, IO, Evaporator, Back Bar (Crimped for Cap Tube)	1
20	Tube, IO, Evaporator, Back Bar	1
21	Standoff, Grille, Back Bar	1
22	LED Driver	1
23	Control	1
24	Red Display	1
25	Top Pull Down Bracket, Back Bar	2
26	Harness Stepper Controller Input	1
27	Standoff	4
28	Panel, Outer Side, High Side	1
29	Panel, Inner Side, High Side, Back Bar	1
30	Base, High Side	1
31	Cover, Back, High Side	1
32	Rail, Condensate Pan, Back Bar	2
33	Pan, Condensate, High Side	1
34	Grille, Front, Back Bar	1
35	Pan, Evaporator, Assembly, Back Bar	1
36	Evaporator Fin Coil	1
37	Baffle, Compressor	1
38	Bracket, Compressor	1
39	L & S Line, 1 Door Back Bar	1
40	Power Cord with Molded Receptacle, 14/3, Back Bar	1



<b>DZS36 MODELS</b>		
<b>ITEM NUMBER</b>	<b>DESCRIPTION</b>	<b>QTY.</b>
41	Wire Harness, Refrigeration Module, Back Bar	1
42	Controller Mounting Bracket	1
43	Controller Board-Damper, Dual Zone Commercial	1
<a href="#">44</a>	Screw, #10 X .500 PH Truss Head	1
45	Screw, Machine, 8-32,2-1/2" Lg Phillip Truss Head, Steel, Black Zinc, Plated	1



### 9.5 Refrigeration Module (DDS60-IR, DDS84-IR, DDS108-IR Model Series)

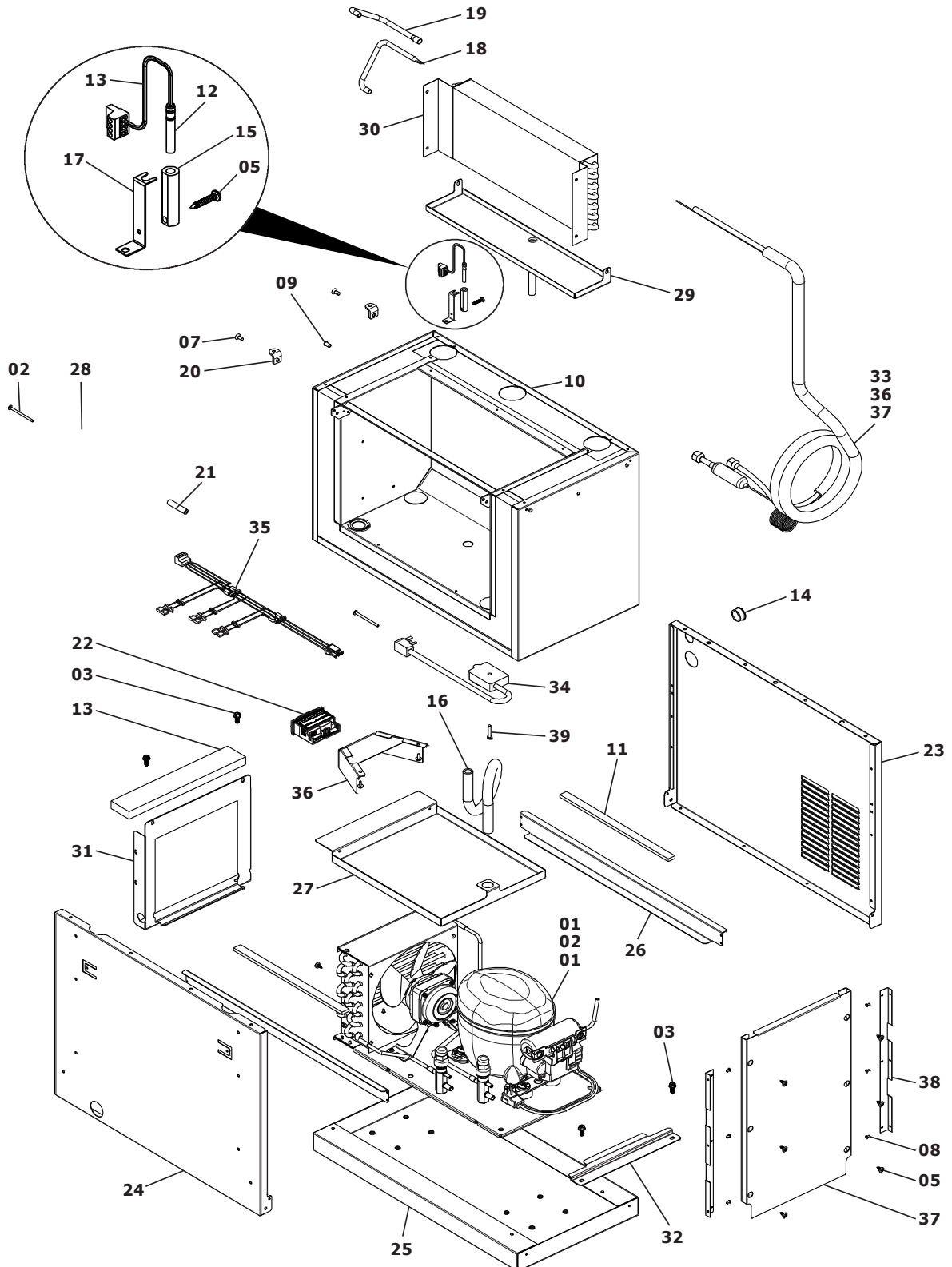



DDS60-IR, DDS84-IR, DDS108-IR MODELS			
ITEM NUMBER	DESCRIPTION	2-DOOR QTY.	3&4-DOOR QTY.
01	Condensing Unit, 1/3 H.P. 115V	-	1
01	Condensing Unit, 1/4 H.P., 115V	1	-
02	Screw, Machine, 8-32, 2-1/2" Lg Phillip Truss Head, Steel, Black Zinc, Plated	2	2
03	Screw, Thread Cutter, 1/4-20 x 5/8 Hex Washer Head, Type 23, Steel	4	4
04	Screw, Sheet Metal, #10 x 1", PH Pan Head, Type "B", Steel, Hardened	1	1
05	Screw, #10 X 1/2" PH Truss Head SMS #410 S.S., Type "AB"	15	10
06	Screw, Sheet Metal, #10-16 x 1/2" Hex Flange Grip-Lite, Type "AB"	14	20
07	Screw, Thread Forming, 1/4-20 X 1/2"	2	2
08	Rivet, Pop, 1/8" Dome Head, S.S., .063" - .125" Grip Range	26	26
09	Rivnut, Insert, #8-32, Steel, Zinc & Yellow Chromate Plated	1	1
10	Low Side Foamed Assembly	1	1
11	Gasket, Low Perm Polyether Foam .25"	2	2
12	Probe, Temperature, NTC, 10K Ohm XW60L, 1.8" Nickel Plated	1	1
13	Foam, Divider, 12"	1	1
14	Snap Bushing, For 1" Hole, Nylon, Black	1	1
15	Sleeve, Sensor Insulating	1	1
16	Tube, Drain, Evaporator Pan to Condenser Pan	1	1
17	Bracket, Temperature Sensor, Back Bar	1	1
18	Tube, IO, Evaporator, Back Bar (Crimped for Cap Tube)	1	1
19	Tube, IO, Evaporator, Back Bar	1	1
20	Top Pull Down Bracket, Back Bar	2	2
21	Standoff, Grille, Back Bar	1	1
22	Control	1	1
23	Panel, Outer Side, High Side	1	1
24	Panel, Inner Side, High Side, Back Bar	1	1
25	Base, High Side	1	1
26	Rail, Condensate Pan, Back Bar	2	2
27	Pan, Condensate, High Side	1	1
28	Grille, Front, Back Bar	1	1
29	Pan, Evaporator, Assembly, Back Bar	1	1
30	Evaporator Fin Coil	1	1
31	Baffle, Compressor	1	1
32	Bracket, Compressor	1	1
33	L & S Line, 2 Door Back Bar	1	-
33	L & S Line, 3 & 4 Door Back Bar	-	1
34	Power Cord with Molded Receptacle, 14/3, Back Bar	1	1



<b>DDS60-IR, DDS84-IR, DDS108-IR MODELS</b>			
<b>ITEM NUMBER</b>	<b>DESCRIPTION</b>	<b>2-DOOR QTY.</b>	<b>3&amp;4-DOOR QTY.</b>
35	Wire Harness, Refrigeration Module, Back Bar	1	1
36	Controller Mounting Bracket	1	1
37	Panel, Back, Flush, High Side, Back Bar	1	1
38	Bracket, Mounting, Flush Back Panel, Back Bar	2	2
39	Screw, #10 X .500 PH Truss Head	1	1



9.6 Fan Motor Assembly Parts (Self-Contained Model Series)

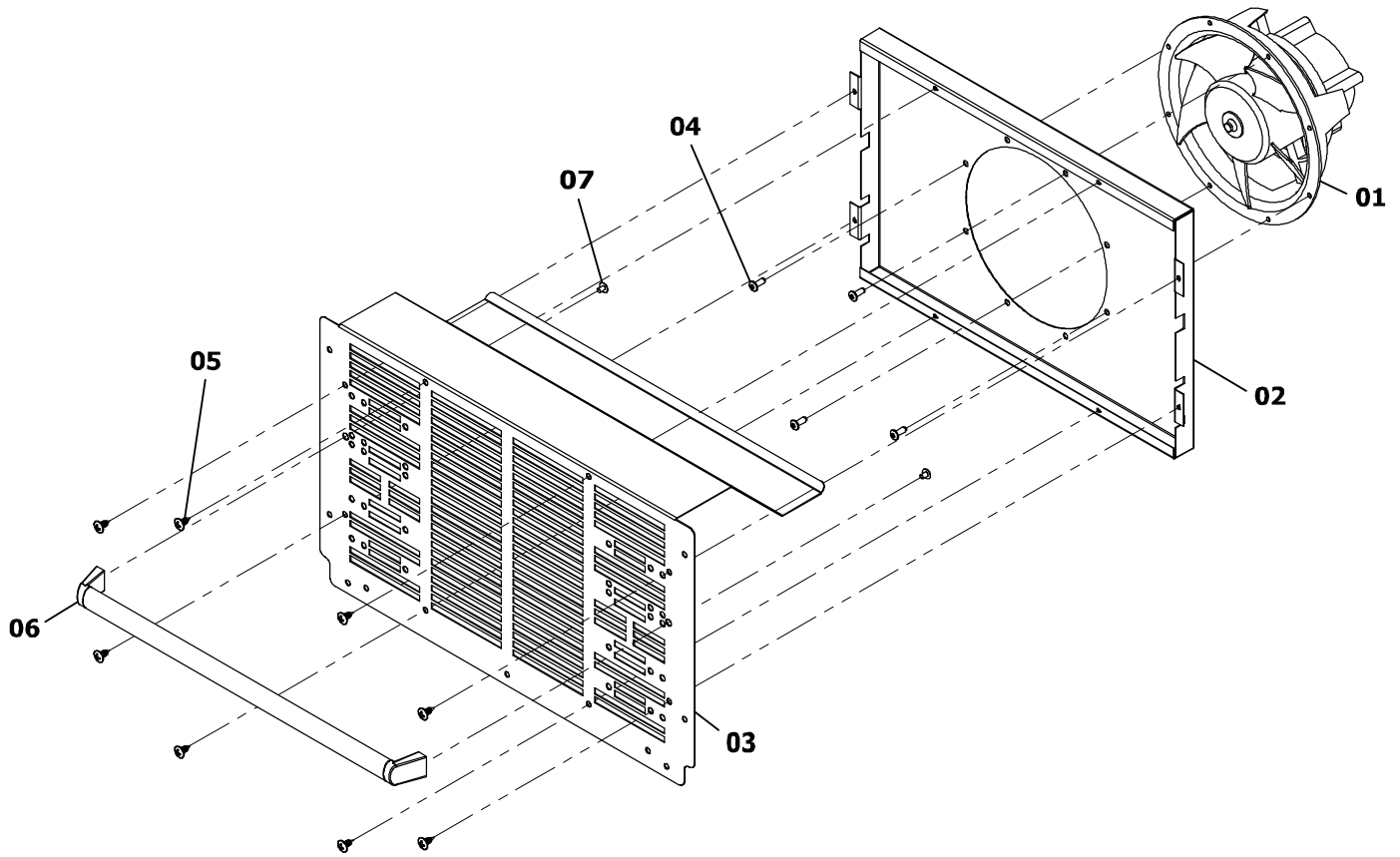

SELF-CONTAINED MODELS		
ITEM NUMBER	DESCRIPTION	QTY.
01	Motor, Fan	1
02	Panel, Fan Mounting	1
03	Panel, Inner Grille	1
04	Screw, Motor Mounting	4
05	Screw, Grille Mounting	8
06	Guard, Product	1
07	Screw, Guard Mounting	2



### 9.7 Low Profile Evaporator Parts (BBSLP Model Series)

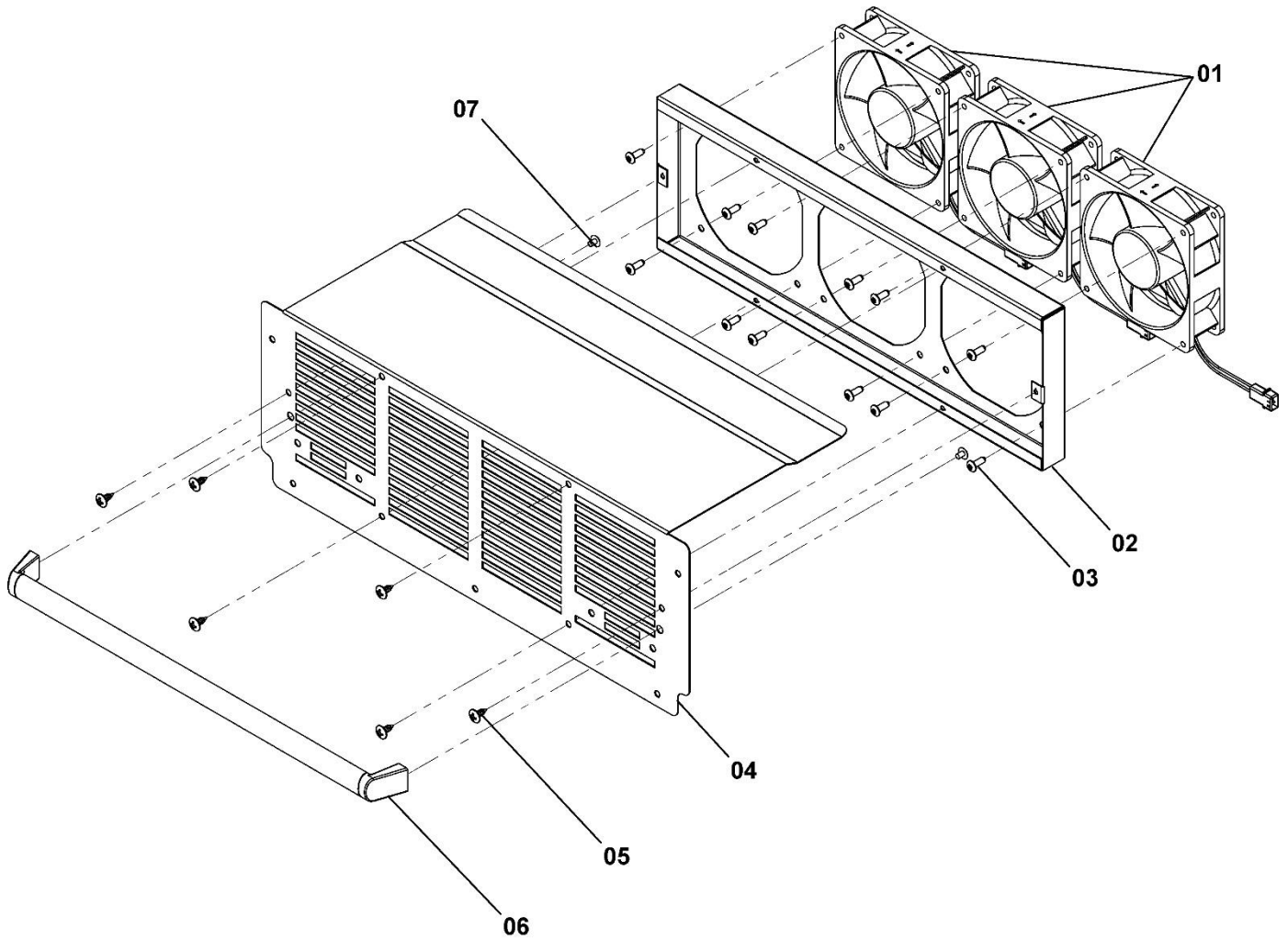

LOW PROFILE MODELS		
ITEM NUMBER	DESCRIPTION	QTY.
01	Fan, Evaporator	3
02	Panel, Fan Mounting	1
03	Screw, Fan Mounting	12
04	Grille	1
05	Screw, Grille Mounting	2
06	Handle, Guard	6
07	Screw, Guard Handle Mounting	2



**9.8 Remote Evaporator Parts (BBR, BBRN, PTR, SDBR & BBRLP Model Series)**

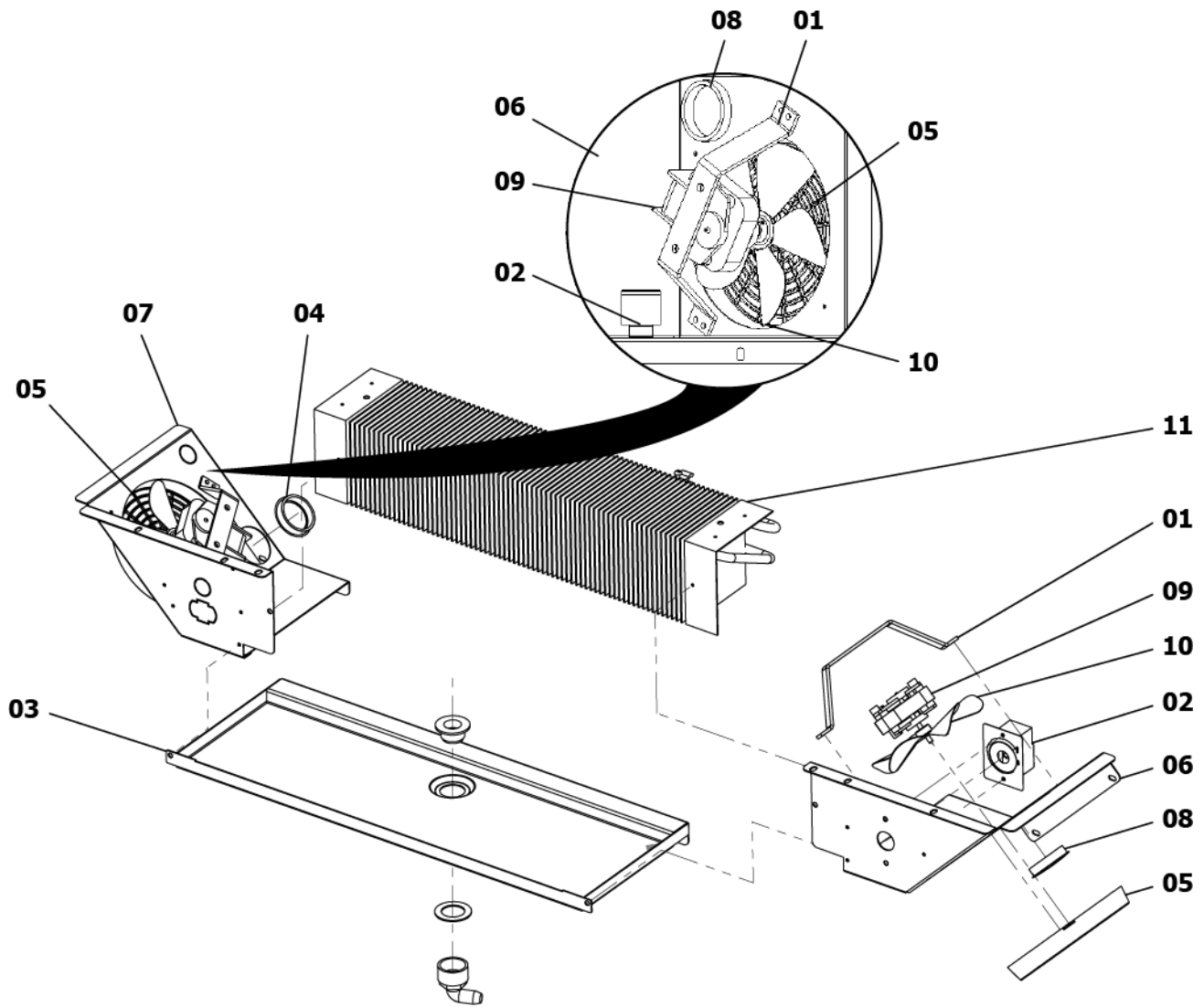

REMOTE MODELS		
ITEM NUMBER	DESCRIPTION	QTY.
01	Motor, Fan	1
02	Panel, Fan Mounting	1
01	Bracket, Fan	2
02	Control, Temperature	1
03	Pan, Evaporator	1
04	Bushing, 1.75" I.D.	1
05	Guard, Plastic Fan	2



REMOTE MODELS		
ITEM NUMBER	DESCRIPTION	QTY.
06	Fan Panel, Evaporator (Right)	1
07	Fan Panel, Evaporator (Left)	1
08	Plug, Dome	1
09	Motor, Fan	2
10	Blade, Fan	2
11	Evaporator Assembly	1
	Coil, 21" Fin	1
	Tube, Evaporator Outlet	1
	Tube, Evaporator Inlet	1
	Clamp, Control Bulb	1
12	Silicone	-



8300 West Good Hope Road • Milwaukee, WI 53223 •  
Toll Free 800.558.5592 • Fax 414.353.7069 • [www.perlick.com](http://www.perlick.com)

