



Installation & Operation Manual

Single Door Undercounter Refrigeration

HC Series / HB Series / HD Series



For HD24RS and HD24WS only



For HB24 and HC24 series only

INTRODUCTION/PREPARING THE CABINET - SINGLE DOOR UNDERCOUNTER CABINETS

Table of Contents

Introduction..... 2

Preparing the Cabinet for Use

 Uncrating and Inspection..... 2

 Plumbing/Electrical 2

Installing the Cabinet

 Preparing the Space..... 3

 Installing Anti-Tip Brackets 3

 Sealing Cabinet to Floor..... 4

 Installing the Unit..... 4

 Toe Plate/Shelving Installation..... 5

Operation Instructions

 Interior Light..... 6

 Electromechanical Temperature Control ... 7

Maintenance

 Defrost..... 8

 Checking Product Temperature 8

 Light Bulb Replacement 9

 Stainless Steel Care Guide 9

 Cleaning Condenser..... 10

Troubleshooting 10

Contact Perlick 11

All Other Models - These products are for the storage and/or display of non-potentially hazardous bottled and canned products only.

Uncrating and Inspection

Remove all crating material. Carefully inspect cabinet for hidden damage. If damage is discovered, file your claim immediately with the transport company. Perlick is not responsible for damage in transit.

Plumbing

No plumbing connections are required. Condensate from the cooling coil automatically evaporated through a condensate pan located in the condensing section of the unit.

Electrical

A 115 volt, 60 Hz, 15 amp circuit breaker and electrical supply are required. A separate circuit is required for each Perlick unit installed.

Follow the National Electrical Code and any local codes or ordinances when installing the receptacle.

All Perlick units come equipped with a NEMA 5-15P 90° plug with a 5' cord extending beyond the rear of the cabinet. The electrical outlet must be flush with, **⚠ DANGER** or recessed into, the wall surface for all HC and HB. HD models have a recess at the rear of the cabinet to accommodate the plug and keep a true 18" depth.

Serious electrocution hazard! Electrical grounding is required. This appliance is equipped with a 3-prong (grounding) polarized plug for your protection against possible shock hazards. Failure to comply with these electrical guidelines may result in possible death or serious injury, fire, or loss of property.

- ▶ **NEVER** remove the round grounding prong from the plug.
- ▶ **NEVER** use a 2-prong adapter.
- ▶ **NEVER** use an extension cord to connect power to the unit.

Additional General Information

- ▶ All electrical instructions assume the outlet is located 4" -10" above the floor surface.
- ▶ Floor must be level in the area of installation.

Thank you for choosing Perlick

To register your product, visit our website at www.perlick.com. Click on 'Bar & Beverage Equipment', then 'Service & Support' and select the 'Warranty Registration Form' option. You must complete and submit this form or the installation date will revert back to the ship date.

This manual has been prepared to assist you in the installation of this cabinet and acquaint you with its operation and maintenance.

We dedicate considerable time to ensure that our products provide the highest level of customer satisfaction. If service is required, your dealer can provide you with a list of qualified service agents. For your own protection, never return merchandise without our approval.

We thank you again for selecting a Perlick product and assure you of our continuing interest in your satisfaction.

Use of Products

Freezer/Chiller - These products are not intended for the open storage of food products.

INSTALLING THE CABINET - SINGLE DOOR UNDERCOUNTER CABINETS

Preparing the Space

⚠ CAUTION If the unit is to be installed under a countertop, it is recommended that the countertop be supported by a structure other than the unit itself to prevent damage to the unit.

⚠ CAUTION Make sure the floor under the unit is level with the surrounding finished floor. Protect a finished floor with plywood, cardboard, or some other suitable material before moving the unit into place. Failure to do this may result in damage to the floor.

1). Make sure the space opening is correctly sized for the unit. See chart below for finished rough opening requirements.

HC24 24" C-Series		
Height*	Depth	Width
32-1/8" minimum	24"	24"

* NOTE: Separately sold leg and caster kit heights should be factored into height if required.

HB24 24" ADA-Compliant Series		
Height*	Depth	Width
32-1/8" minimum	24"	24"

* NOTE: Separately sold leg and caster kit heights should be factored into height if required.

HD24 18" Shallow-Depth Series		
Height*	Depth	Width
32-1/8" minimum	18"	24"

* NOTE: No accessory leg or caster kits are available for the HD24 products.

NOTE: For a cabinet door to open properly, the door must open a minimum of 90°. Use a minimum 3" filler in corner installations to assure a full 90° opening. Allow 25" clearance in front of unit for full door swing and shelf/drawer pull out for all units.

2). Check that the following are level and square:

- ▶ Front and interior opening
- ▶ Installation opening and floor surface
- ▶ Countertop bottom and front edge (if applicable)

⚠ CAUTION NOTE: The floor under the unit must be at the same level as the surrounding finished floor. To prevent possible damage to the countertop do not place heavy objects on countertop directly over unit.

Installing Anti-Tip Brackets

Unit may tip forward if loaded racks/shelves are all pulled out at the same time. To prevent tipping, and to provide stable installation, the unit must be secured in place with the anti-tip brackets supplied with the unit. The anti-tip brackets, when properly installed, should secure the rear legs/glides to the mounting surface and prevent the unit from tipping forward.

Please note:

- ▶ Anti-tip brackets are only used for stationary cabinets and should not be installed on cabinets with accessory casters. Caster kits are available for HC and HB model cabinets. Refer to the instructions supplied with the caster kit for proper installation.
- ▶ If installing on a concrete floor, concrete fasteners are required and not included with the anti-tip kit.
- ▶ Some installation sites may require modifications to provide a secure surface for attaching the brackets.

A set of anti-tip brackets is supplied with the unit. These brackets should be attached to the floor at the rear of the unit. Each bracket must be located to engage the rear glides when the cabinet is pushed back into position. Refer to Figure 1 (shown below) for anti-tip bracket mounting locations.

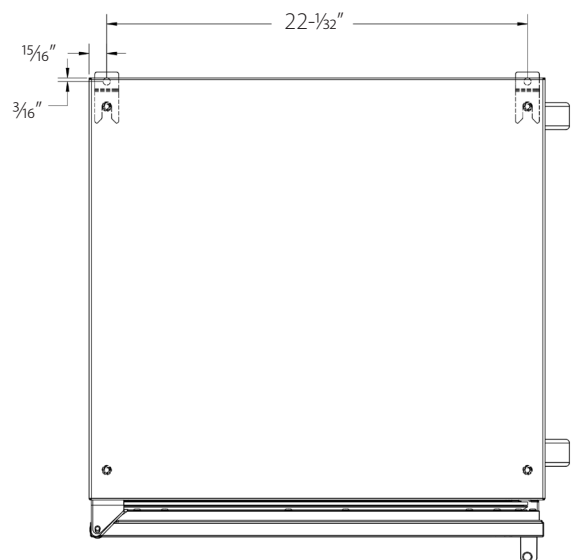
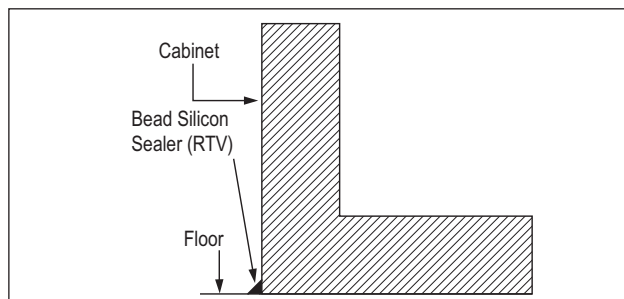

Figure 1. 24" Anti-Tip Bracket

INSTALLING THE CABINET - SINGLE DOOR UNDERCOUNTER CABINETS

Sealing Cabinet to Floor

For units without casters or legs, it may be necessary to seal the base of the cabinet to the floor. This can be accomplished by laying a bead of silicone sealant between the base of the cabinet and the floor (Figure 1).



Sealing Cabinet to Floor

Installing the Unit

1). Plug the unit into the 15 amp grounded electrical outlet located within the installation opening. With power applied to the unit, check that the lighting and cooling functions operate properly. Turn off the power to the wall outlet at the circuit breaker.

2). Slide the unit into position in the opening. Make sure the rear glides slide under the anti-tip brackets. Push the unit into the opening until the bottom front edge of the unit is flush with the surrounding cabinetry, or until the rear glides are tight against the anti-tip brackets.

NOTE: The rear glides must be engaged under the anti-tip brackets.

NOTE: Countertop should be resting evenly on entire top of the unit. Shim if necessary to prevent damage to the countertop.

3). Check interior door openings to make sure the unit is level and square. Install shelving and/or drawers. Place the slide brackets squarely into the bracket grooves. When installed properly, a "click" should be heard from the slide bracket retaining tabs and the brackets should slide smoothly. The retaining tabs will stop the shelf/drawer when pulled out to full extension.

4). Turn the power on to the circuit breaker.

NOTE: Improper shelf/drawer installation may not actuate slide mechanism.

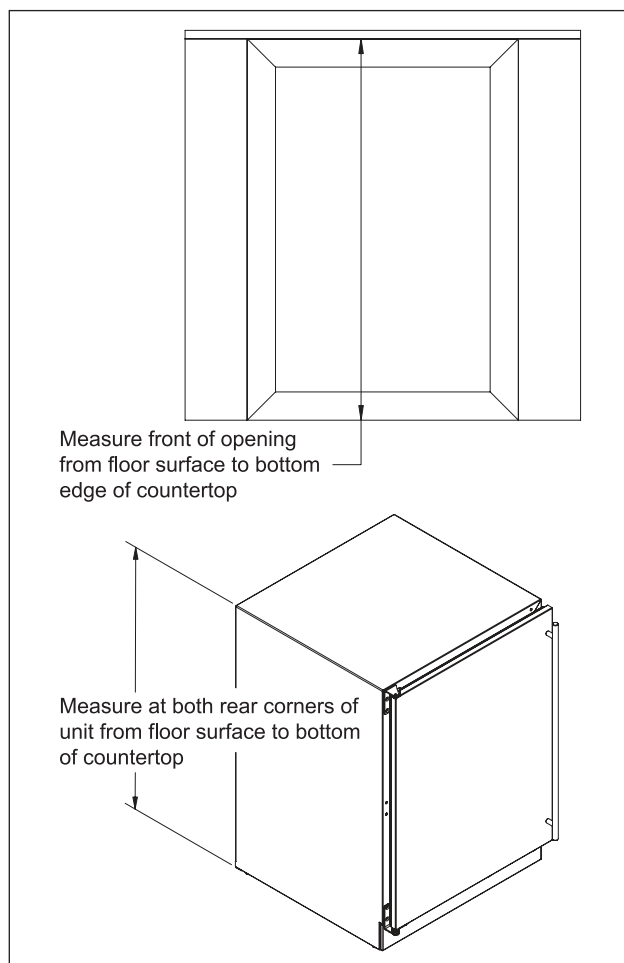

Leveling the Unit

Toe Plate Installation

Once the unit is secured in place, install the louvered toe plate. Secure the plate by snapping the latch into the latch catch on the unit as shown in Figure 3.

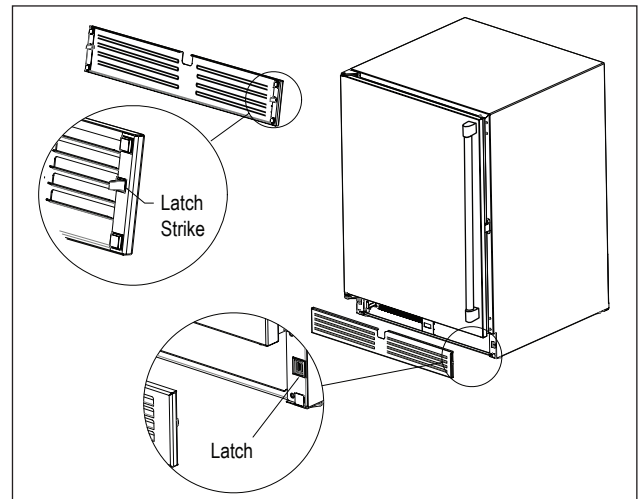

Figure 3. Toe Plate Installation

Shelving

Each cabinet comes with standard shelving (drawer models excluded). All shelves are black vinyl-coated, full-extension pullout shelves. Wine shelves have stainless steel front.

Refrigerator - Two (2) refrigerator shelves

Freezer/Chiller - Two (2) refrigerator shelves

Beverage Center - Two (2) wine shelves and one (1) refrigerator shelf

Wine Reserve - Five (5) wine shelves

To adjust the shelving:

- 1). Pull the shelf out to its farthest position. Locate the tabs in the middle of both extends, then press tabs and pull shelf out of the unit. See Figure 4
- 2). Reposition each bracket separately. Grasp the middle of the bracket, pull the front end up and out, then forward to remove.
- 3). Place bracket at the desired position. Push the rear hook into the rear key slot. Set front bracket on the wall hook.
- 4). Repeat for other bracket(s).
- 5). Push extenders completely into the unit. Align the shelf grooves with the extenders and slide completely into the unit.

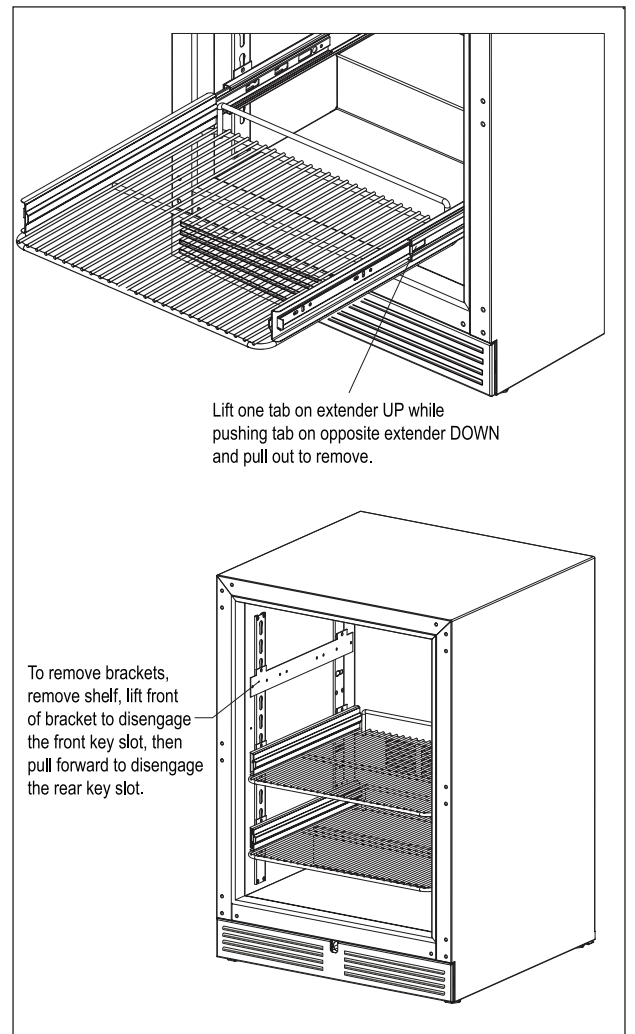

Figure 4. Adjusting Shelf Position



Interior Light

Interior Light

All door units are equipped with an interior light that illuminates when the door is opened. The cabinet also comes equipped with a manual light switch for displaying the products through a glass door. For C-Series (HC), ADA-Compliant (HB) and Shallow-Depth (HD) models, this is located on the back wall left of the light.

Always ensure that the manual light switch is in the OFF position before closing a solid wood or stainless steel door. If manual light switch is left on for an extended period of time, it may increase the cabinet temperature, and cause the refrigeration system to run harder.

Loading Product

Before storing perishables, turn unit on and allow it to operate for a minimum of 24 hours to allow temperatures to stabilize.

When loading items into the unit, do not block internal louvers and fan guard openings or performance will be decreased.

Electromechanical Temperature Control

Perlick Single Door Refrigerator, Beverage Center and Wine Reserve units come standard with an electromechanical temperature control (Figure 6).

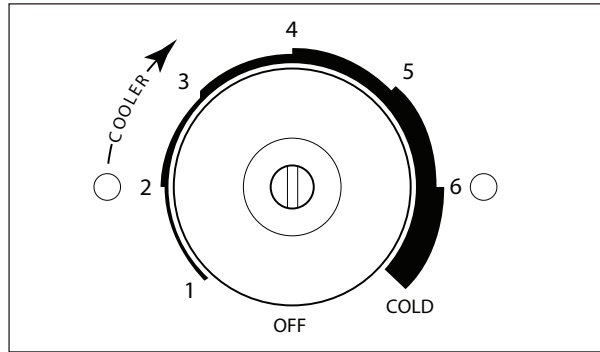

Figure 6. Electromechanical Temperature Control

Electromechanical Controller Operating Instructions

Use a straight slot screwdriver to adjust the dial temperature control. The control is located at the top rear panel of the cabinet. Approximate temperature ranges are as follows:

HC24 24" C-Series	
Model	Factory Temp Setpoint
HC24FS	0° F
HC24RS	38° F
HC24WS	45° F

HB24 24" ADA Compliant Series	
Model	Factory Temp Setpoint
HB24FS	0° F
HB24RB	38° F
HB24BB	42° F
HB24WB	45° F

HD24 18" Shallow-Depth Series	
Model	Factory Temp Setpoint
HD24RS	38° F
HD24WS	45° F

To Adjust to Colder Temperature: Turn the adjusting screw clockwise (to the left)

To Adjust to Warmer Temperature: Turn the adjusting screw counterclockwise (to the right)

To Turn Temperature Control OFF: Turn the adjusting screw completely counterclockwise to the OFF position until a click is heard.

NOTE: Condenser fan motor turns off with compressor.

MAINTENANCE - SINGLE DOOR UNDERCOUNTER CABINETS

Defrost

HC24FS is equipped with a 4 hour evaporator hot gas defrost system. Additionally, there is a manual momentary close switch located in the center of the louvered toe plate that actuates a 6 hour cabinet defrost to clear ice buildup on frosted/chiller glasses/mugs/plates.

The HB24FS is equipped with a evaporator hot gas defrost system to allow maintenance free operation of the cooling system.

All other models employ off cycle defrost.

Checking Product Temperature

To accurately check the temperature of product stored in the refrigerated compartment:

1. Insert an accurate thermometer into an unbreakable plastic bottle, partially filled with water. Tighten bottle cap securely.
2. Place bottle in the desired area for 24 hours. Refrain from opening the unit during the testing period. After 24 hours, check the temperature of the water and adjust using the Controller Operating Instructions on page 6.

⚠ DANGER Never attempt to repair or perform maintenance on the unit until the main electrical power to the unit has been disconnected.

MAINTENANCE - SINGLE DOOR UNDERCOUNTER CABINETS**Light Bulb Replacement**

To replace a defective or burnt out bulb, remove the glass light cover by pulling off the cover. Unscrew the bulb and replace it with an identical or smaller bulb. The Perlick replacement part number is 67026.

Stainless Steel Care

Stainless steel is a “passive” metal because it contains other metals like chromium, nickel and manganese that stabilize the atoms. Chromium provides an invisible passive film that covers the steel surface, acting as a shield against corrosion. As long as the film is intact and not contaminated, the metal is passive and stainless. If the passive film of stainless steel has been broken, equipment can start to corrode and rust.

Three materials or processes can break down stainless steel’s passive layer and allow corrosion to occur:

- ▶ Mechanical abrasion
- ▶ Deposits and water
- ▶ Chlorides

Mechanical abrasion refers to items that will scratch a steel surface. Steel pads, wire brushes and scrapers are prime examples.

Water comes out of the faucet in varying degrees of hardness. Hard water may leave spots. When allowed to sit, these deposits will break down the passive chromium layer and rust stainless steel. Other deposits from food preparation must be promptly removed with an appropriate cleaning agent.

Chlorides are found nearly everywhere. They are in water, food and table salt. Household and industrial cleaners are the worst offenders.

Preventing Stainless Steel Rust

Use non-abrasive tools to clean stainless steel products. Soft cloths and plastic scouring pads will not harm the steel’s passive layer.

Clean with polish lines. Some stainless steels have visible polishing lines or “grain”. When visible lines are present, always scrub in a motion parallel to the lines. When the grain cannot be seen, polish in a consistent straight pattern and not in a circular motion.

Use alkaline, alkaline chlorinated or non-chloride containing cleaners. While many traditional cleaners are loaded with chlorides, the industry is providing an ever-increasing choice of non-chloride cleaners. If you are not sure of chloride content in the cleaner being used, contact your cleaner supplier. If your present cleaner contains chlorides, ask your supplier for an alternative. Avoid cleaners containing quaternary salt; it also can attack stainless steel and cause pitting and rusting.

Keep food equipment clean. Use alkaline, alkaline chlorinated or non-chloride cleaners at recommended strength. Clean frequently to avoid build-up of hard, stubborn stains. The single most likely cause of damage is chlorides in the water. Remember, adding heat to cleaners that contain chlorides dramatically increases their effect on stainless steel.

If chlorinated cleaners are used, immediately rinse and wipe equipment and supplies dry. The sooner you wipe standing water, especially when it contains cleaning agents, the better. After wiping equipment down, allow it to air dry. Oxygen helps maintain the stainless steel passive film.

Cleaning the Cabinet Interior/Exterior

⚠ CAUTION NEVER use hydrochloric acid (muriatic acid) on stainless steel. Do not use abrasive cleansers on cloths on any interior or exterior surfaces, including removable parts.

Glass panels may be cleaned using any standard glass cleaner available on the market.

To clean interior and exterior non-metallic surfaces and removable parts, wash with mild solution of soap and lukewarm water with a little baking soda. Rinse and dry thoroughly. Avoid getting water on the lights, controllers, fan motors and unfinished wood wine rack faces.

Recommended Cleaners for Specific Situations

Job	Cleaning Agent	Comments
Routine cleaning	Soap, ammonia, detergent	Apply with sponge or soft cloth
Fingerprints and smears	Areal 20, Lac-O-Nu, Lumin Wash, O-Cedar Cream Polish	Provides barrier film to minimize fingerprints. Can be used on all finishes. Rub the surface with a cloth as directed on the package.
Stubborn stains and discolorations	AllChem Concentrated Cleaner, Samae, Twinkle, Cameo Copper Cleaners, Grade FFF Italian Pumice Whiting, Steel Bright, Lumin Cleaner, Zud Restoro, Sta-Clean, Highlite Cooper's Stainless Steel Cleaner or Revere Stainless Steel Cleaner	Apply with a damp sponge or cloth, then rinse with clear water and wipe dry.
	Old Dutch, Lighthouse Sunbrite, Wyandotte Bab-O, Gold Dust, Sapollo, Bon Ami or Comet	For these household cleaners, rub with a damp cloth. They may contain chlorine bleaches so rinse thoroughly after use and wipe dry.
	Liquid NuSteel or Dubois Temp	For these products, rub the surface with a dry cloth using only a small amount of cleanser. Rinse with water and dry.
Heat tint or heavy discoloration	Penny-Brite, Copper Brite, Paste Nu-Steel, Dubois Temp or Tarnite	Rub onto surface with a dry cloth
	Bar Keepers Friend, Revere Stainless Steel Cleaner, Allen Polish, Steel Bright Wyandotte Bab-O or Zud	When using these cleaners, apply with a damp sponge or cloth, rinse thoroughly and wipe dry.
Tenacious deposits, rust, discoloration, industrial atmospheric stains	Oakite No. 33 Dilac, Texo NY, Flash-Klenz Caddy Cleaner, Turco Scale 4368 or Permag 57	Swab and soak with a clean cloth. Let stand for 15 minutes or more according to directions on package, then rinse and wipe dry.
Rust discoloration or corrosion caused by cleaning agents containing hydrochloric (muriatic) acid or chlorine bleach	3M Scotch Pad, type A, grade "fine"	Clean off the surface soil using cleaning methods above. Then rub discolored or corroded areas lightly with a dry pad.

Use of property names is intended only to indicate a type of cleaner and does not constitute an endorsement. Omission of any proprietary cleaner does not imply its inadequacy. All products should be used in strict accordance with instructions on the package.

NOTE: Do NOT use steel wool or scouring pads to clean stainless steel.

⚠ DANGER Never attempt to repair or perform maintenance on the unit until the main electrical power to the unit has been disconnected.

Cleaning the Condenser

The condenser (located behind the louvered toe plate) should be cleaned every three (3) months. Use a soft bristle brush and vacuum to remove dust and lint.

⚠ CAUTION Avoid damaging or crushing the condenser fins or tubing.

⚠ CAUTION Failure to clean the condenser could result in temperature loss or mechanical failure.

TROUBLESHOOTING - SINGLE DOOR UNDERCOUNTER CABINETS

If the unit appears to be malfunctioning, read through the operation section first, then check the guide below to identify and resolve the problem.

⚠ DANGER Electrocutation hazard! Never attempt to repair or perform maintenance on the unit until the main electrical power has been disconnected.

No Interior Light

- ▶ Is the bulb loose?
- ▶ Is the bulb burnt out?

Light stays on when the door is closed

- ▶ Manual ON/OFF light switch is turned on.
- ▶ Is the door switch making contact with the plunger?

Noisy during operation

- ▶ Certain sounds are normal. Soft sounds from the compressor, fan motor and valves may be heard.

The refrigerated cabinet isn't running

- ▶ Is there electrical power running to the unit?
- ▶ Is the building circuit breaker/fuse on?
- ▶ Is the control set properly?
- ▶ Is the condenser area clean?

The refrigerated compartment is warmer than usual

- ▶ Is the control set properly?
- ▶ Is the light staying on?
- ▶ Is the condenser area clean and free of obstruction?
- ▶ Has the door or drawer been open for a long time or have more frequent door or drawer openings occurred?
- ▶ Are the internal louvres and fan guard openings being obstructed?

- ▶ Is the door or drawer closing and sealing properly?

The refrigerated compartment is cooler than usual

- ▶ Is the control set properly?
- ▶ Is the door or drawer closing and sealing properly?

The refrigeration system runs for long periods of time

- ▶ Is the condenser area clean and free of obstruction?
- ▶ Has the door or drawer been open for long periods of time or have more frequent door or drawer openings occurred?
- ▶ Has warm product just been placed in the unit?
- ▶ On hot days and in warm room temperatures, the system will run longer.

Condensation forms inside the refrigerated compartments

- ▶ This is normal during high humidity and with frequent door openings.
- ▶ Are the doors and drawers closing and sealing properly?

Condensation forms on the outside of the unit

- ▶ During periods of high humidity, some condensation might appear on the outside surfaces. The condensation will disappear when the humidity drops. Meanwhile, be sure the doors and drawers are closing and sealing properly. If condensation persists, contact your Perlick Factory Authorized Service Center.

PRODUCT INFORMATION AND CONTACT INFORMATION**To obtain product information**

- ▶ Contact your selling dealer
- ▶ Inquire on the web at www.perlick.com
- ▶ Call (800)558-5592 for factory assistance for planning, installation or product information
- ▶ Write Perlick Corporation, Customer Service Department, 8300 W. Good Hope Rd., Milwaukee, WI 53223.
- ▶ Email us at warrantyserv@perlick.com

To obtain product service, replacement parts or accessories

- ▶ Use only genuine Perlick replace parts and accessories. Genuine Perlick parts and accessories are designed to work correctly with Perlick products and offer superior service life. The use of non-Perlick parts can damage the unit and may void the warranty.
- ▶ Check the model and serial number of the unit located on the label attached to the ceiling inside of the cabinet. Call a Perlick Factory Authorized Service Center. For the location of the nearest Service Center, use the contact information listed above.



QUALITY & INNOVATION
THAT **INSPIRES**

Additional product information and specifications are available for download on perlick.com.

Contact Perlick Customer Service or Technical Service toll-free at 800.558.5592.

Customer Service and Technical Service are available business days Monday through Friday from 8 a.m. to 4:30 p.m. CST.

Perlick Corporation | 8300 W. Good Hope Rd., Milwaukee, WI 53223
(800)558-5592 • info@perlick.com