

STACKING KIT INSTALLATION

IMPORTANT

For built-in applications only! Ensure the anti-tip brackets are installed per the installation manual that came with the cabinet. Never install if used with caster kits or extended leg kits.

Tools Required



Phillips
Screwdriver

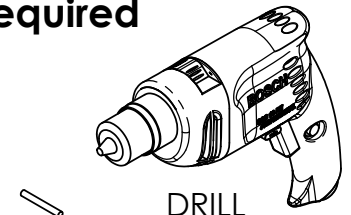

DRILL

5/32" DRILL BIT

Parts Required

Part Number	Description	HP15		HP24, HC24, & HA24		HH24		HP48
		Left Hinged Door	Right Hinged Door	Left Hinged Door	Right Hinged Door	Left Hinged Door	Right Hinged Door	Left & Right Hinged Door
69608-1	15" Grill, Left Hinged Door	1	-	-	-	-	-	-
69609-1	15" Grill, Right Hinged Door	-	1	-	-	-	-	-
68837	15" Grill Mounting Bracket	1	1	-	-	-	-	-
69603-1	24" Grill, Left Hinged Door	-	-	1	-	1	-	1
69604-1	24" Grill, Right Hinged Door	-	-	-	1	-	1	1
68836	24" Grill Mounting Bracket	-	-	1	1	1	1	2
68094-15	15" Mounting Plate	1	1	-	-	-	-	-
68094-24	24" Mounting Plate	-	-	1	1	-	-	-
68094-24x18	24" x 18" Mounting Plate	-	-	-	-	1	1	-
68094-48	48" Mounting Plate	-	-	-	-	-	-	1
63965	Latch Strike	2	2	2	2	2	2	4
63966	Latch	2	2	2	2	2	2	4
C31323	Bumper, Adjesive Poly	4	4	4	4	4	4	8
M00885-189	1/4-20 x 1/2" Machine Screw	4	4	4	4	4	4	6
M50050-466	#10 x 1/2" Sheet Metal Screw	4	4	4	4	4	4	11

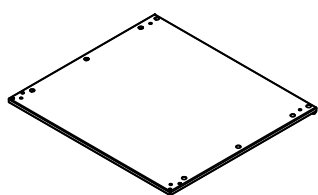

15" & 24" Mounting Plate

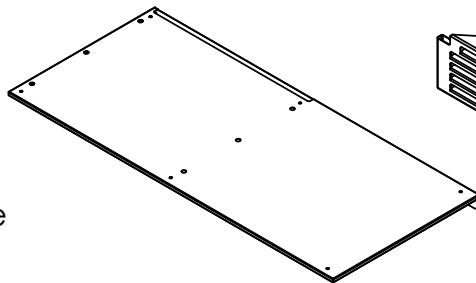

48" Mounting Plate

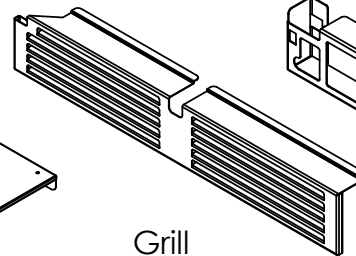

Grill

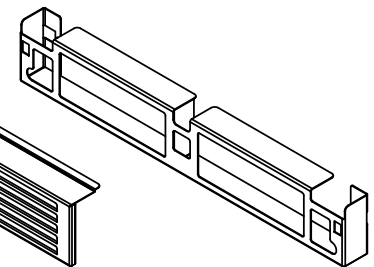

Grill Mounting Bracket



Latch



Latch Strike



#10 x 1/2" Sheet Metal Screw



1/4-20 x 1/2" Machine Screw



Bumper, Adhesive Poly



Perlick Corporation

Milwaukee, WI 53223

RELEASE FOR PRODUCTION

A 3/12/2014 JMP

REVISIONS

SCALE 1:5
DRAWN JMP DATE 3/12/2014

95220

STACKING KIT INSTALLATION

CAUTION: These cabinets are extremely heavy. Ensure that you have enough people on hand to help in repositioning the units so that it can be done safely and without damage.

Step 1: Drill out top row of rivets along back of the bottom cabinet using a 5/32" drill bit.

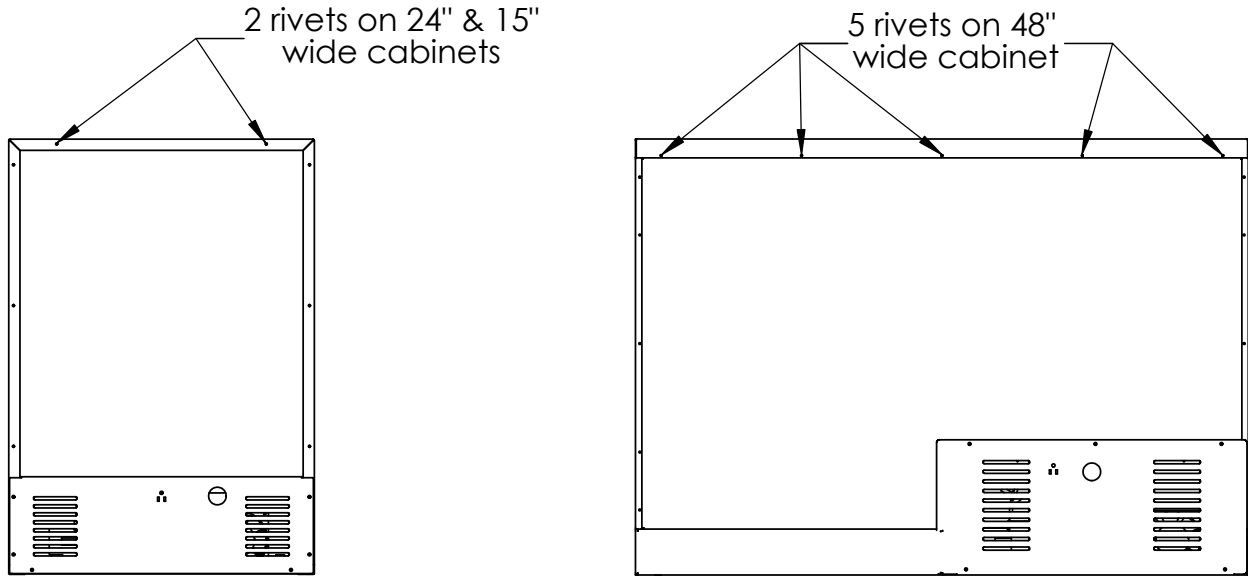

Step 2: Lay upper cabinet on its back and remove leg levelers and grill(s) from unit.

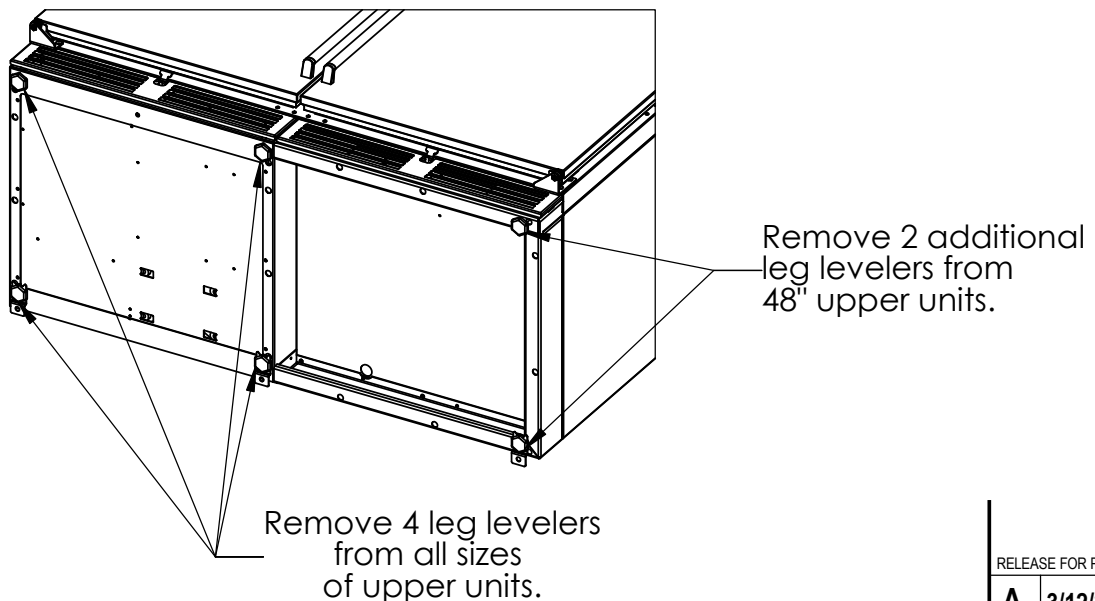

Perlick Corporation
Milwaukee, WI 53223

RELEASE FOR PRODUCTION

A 3/12/2014 JMP

REVISIONS

SCALE 1:15
DRAWN JMP DATE 3/12/2014

95220

STACKING KIT INSTALLATION

Step 3: Attach mounting plate (where the leg levelers were removed in step 2) by using 1/4-20 machine screws. Flange should be pointing away from the bottom of the unit.

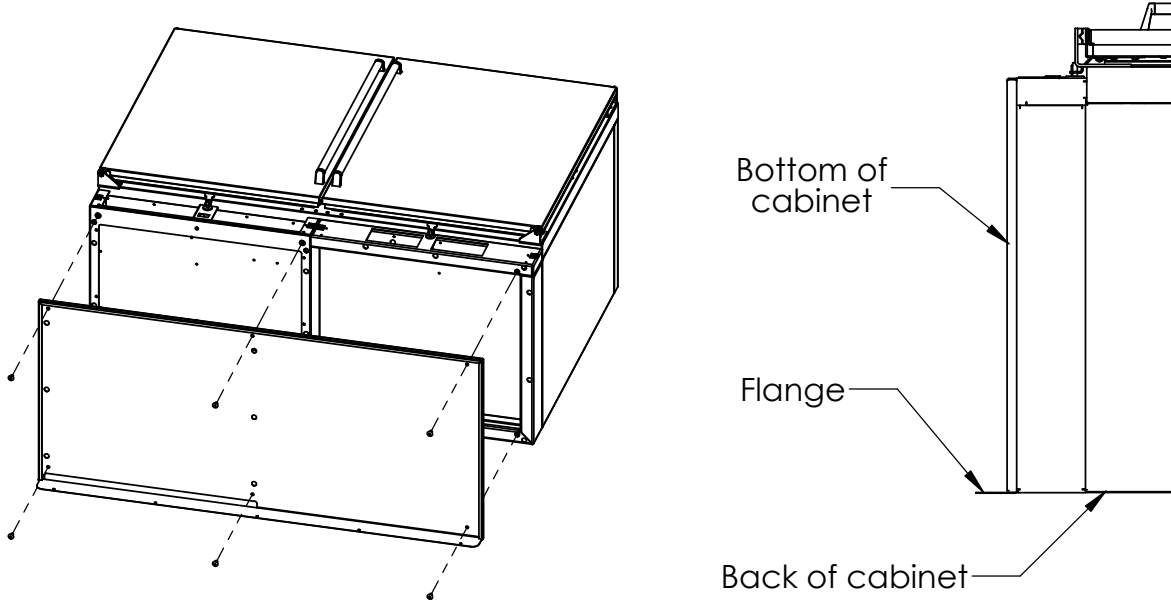

Step 4: Place upper unit on top of lower unit and attach using #10 sheet metal screws (where the rivets were drilled out in step 1).

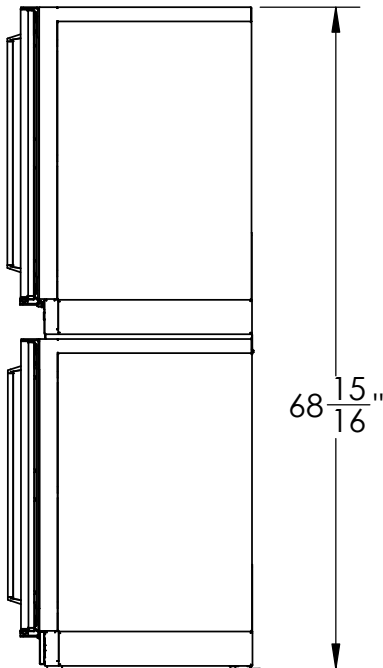

Note: To prevent damage to the compressor, wait 24 hours before powering on unit after turning the cabinet back to its upright position.

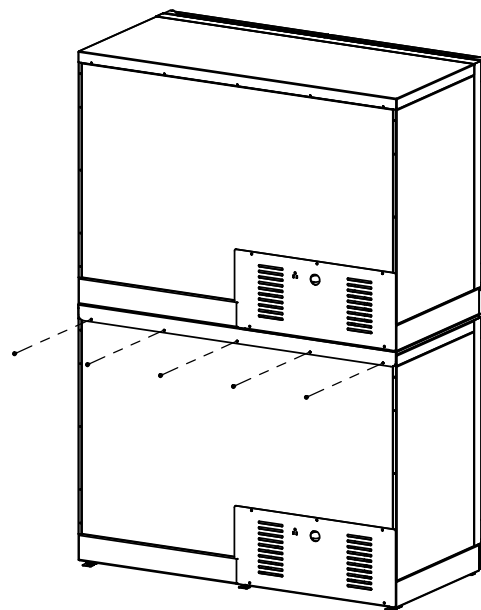

NOTE: Extension of leg levelers will increase assembly height.



Perlick Corporation

Milwaukee, WI 53223

RELEASE FOR PRODUCTION

A 3/12/2014 JMP

REVISIONS

SCALE 1:20
DRAWN JMP DATE 3/12/2014

95220

STACKING KIT INSTALLATION

Step 5: Remove (2) #10 sheet metal screws from the front of the top cabinet (These screws will be used to attach the mounting bracket) Attach mounting bracket(s) to the front of the cabinet using #10 sheet metal screws. Install latches into the grill bracket(s).

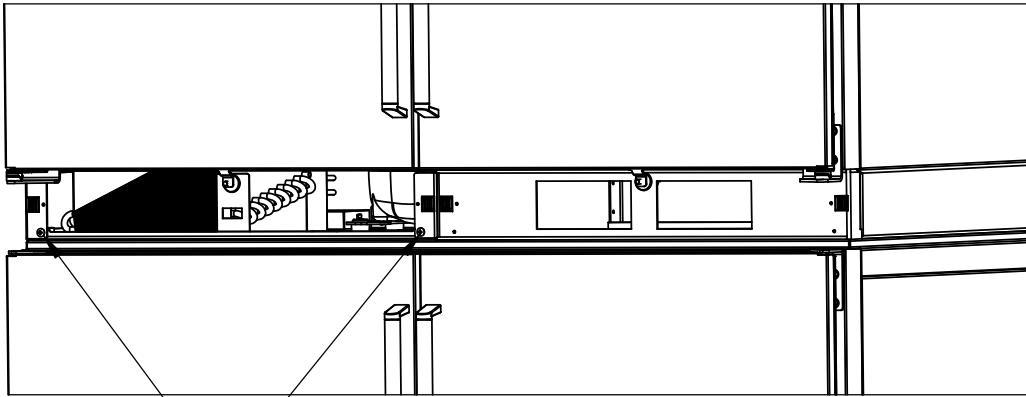

Remove (2) screws from front of cabinet.

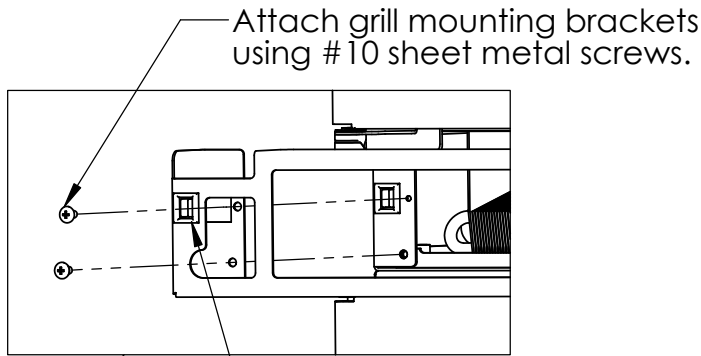

Attach grill mounting brackets using #10 sheet metal screws.

Install latches to grill mounting bracket.

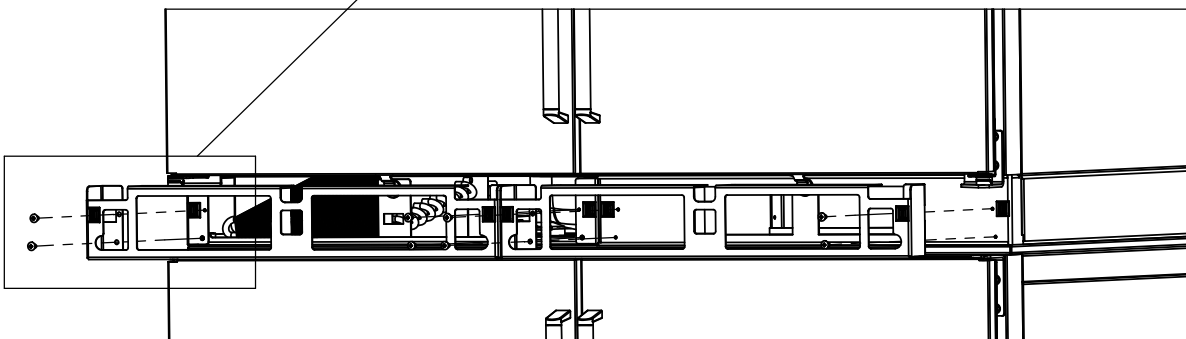

RELEASE FOR PRODUCTION

A 3/12/2014 JMP

REVISIONS

SCALE 1:20
DRAWN JMP DATE 3/12/2014

95220



Perlick Corporation

Milwaukee, WI 53223

STACKING KIT INSTALLATION

Step 6: Attach (4) bumpers and (2) latch strikes to each new grill. Orient the tabs on the latch strike vertically. Attach grill assembly to upper unit. Move stacked assembly into final position by pushing lower unit.

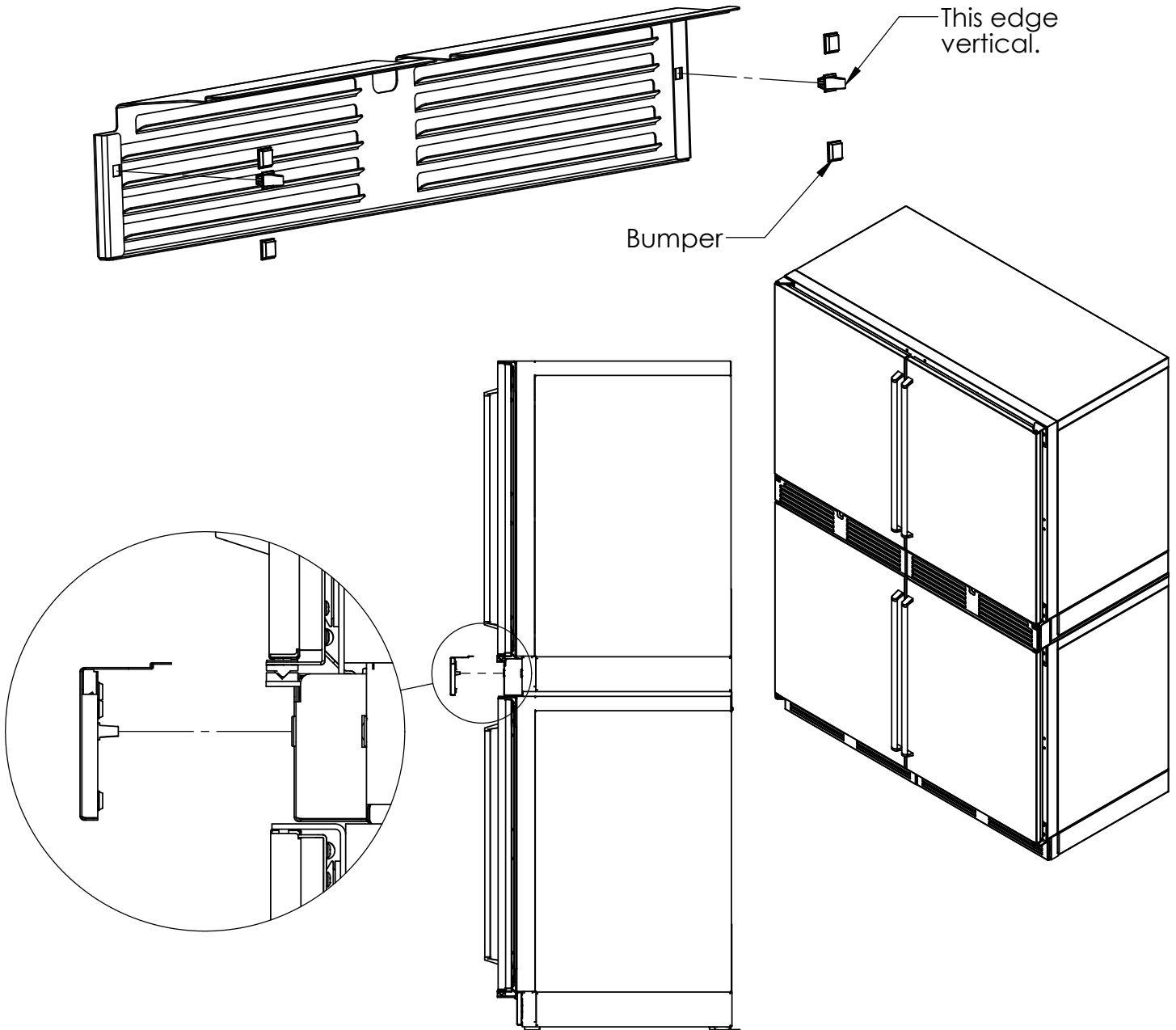

Note: When using stacking kit to join (2) HH24 or HA24 units, a wall mount anti-tip kit must be installed. See cabinet installation manual for instructions.



Perlick Corporation
Milwaukee, WI 53223

RELEASE FOR PRODUCTION

A 3/12/2014 JMP

REVISIONS

SCALE 1:20
DRAWN JMP DATE 3/12/2014

95220