

STACKING KIT INSTALLATION

IMPORTANT

For built-in applications only!
 Ensure the anti-tip brackets are installed per the installation and operating manual that came with the cabinet.
 Never install if used with caster kits or extended leg kits.

Tools Required

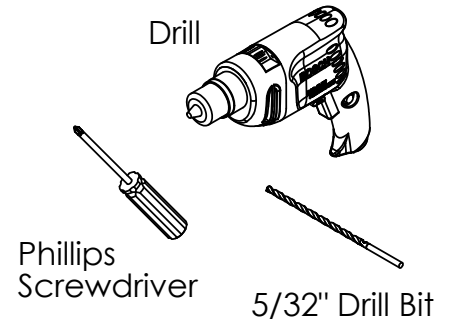

		Parts Required				
Part Number	Description	MODEL				
		HP15	HP24 & HC24	HH24 & HC24-18	HP48	HP72
63965	LATCH STRIKE	2	2	2	4	6
65700-2	15" Grille	1				
65733-4	24" Grille		1	1	2	3
68094-15	15" Mounting Plate	1				
68094-24	24" Mounting Plate		1			
68094-24x18	24"x18" Mounting Plate			1		
68094-48	48" Mounting Plate				1	
68094-72	72" Mounting Plate					1
C31323	Bumper, Adhesive Poly	4	4	4	8	12
M00885-189	1/4-20 X 1/2" MACHINE SCREW	4	4	4	6	6
M50050-466	#10 X 1/2" SHEET METAL SCREW	2	2	2	5	5

1/4-20 X 1/2" MACHINE SCREW

#10 X 1/2" SHEET METAL SCREW

BUMPER, ADHESIVE POLY

LATCH STRIKE

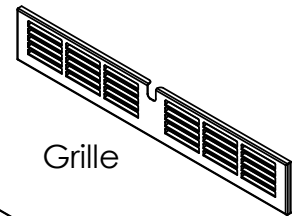

Grille

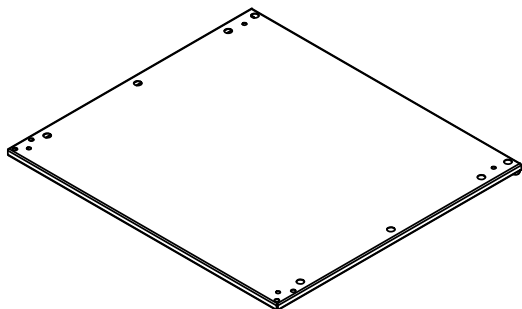

15" & 24" Mounting Plate

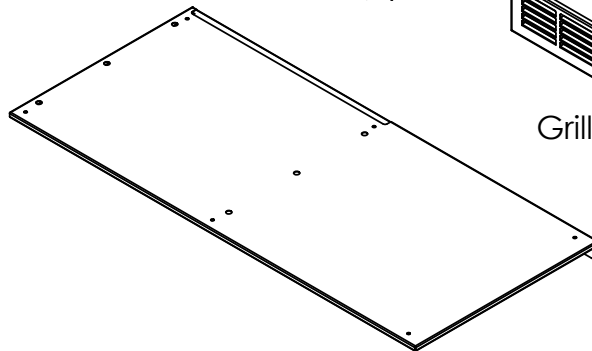

48" & 72" Mounting Plate



STACKING KIT INSTALLATION

CAUTION: These cabinets are extremely heavy. Ensure that you have enough people on hand to help in repositioning of the units so that it can be done safely and without damage.

Step 1: Drill out top row of rivets along back of the bottom cabinet using 5/32" drill bit.

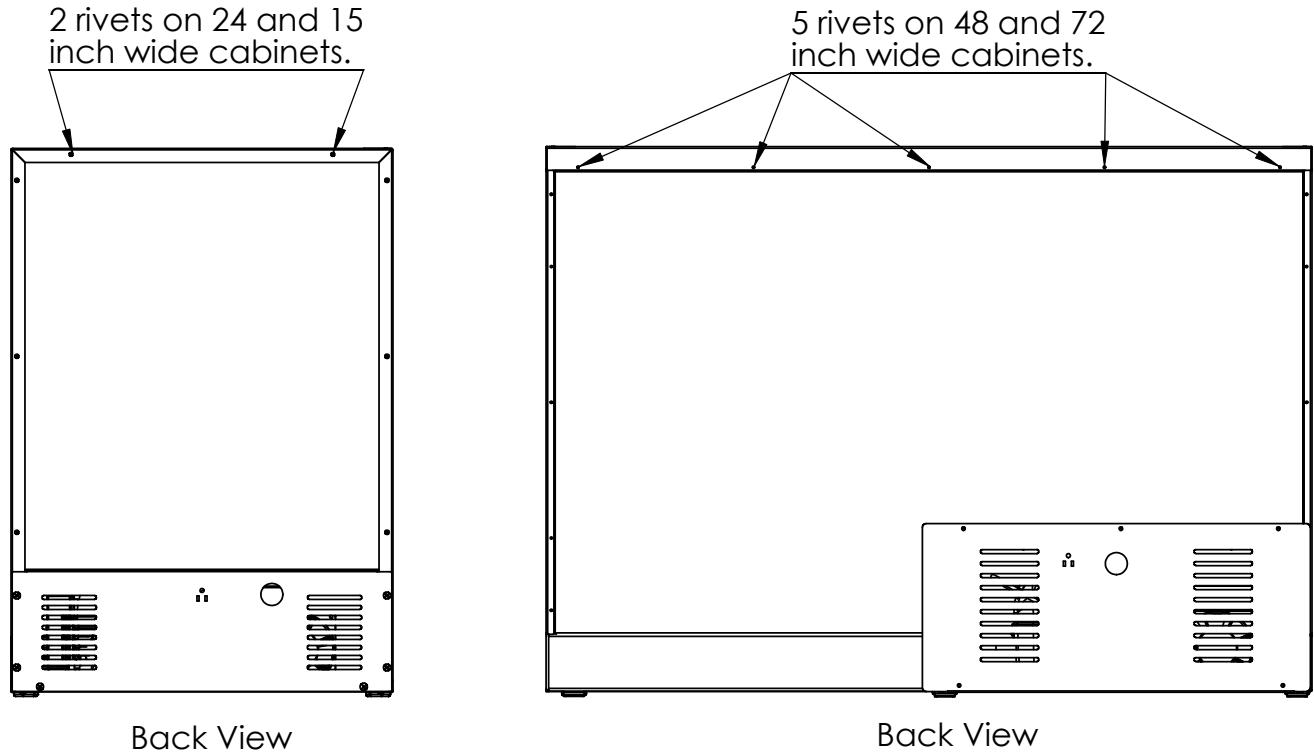

Step 2: Lay upper cabinet on its back and remove leg levelers and grille(s) from unit.

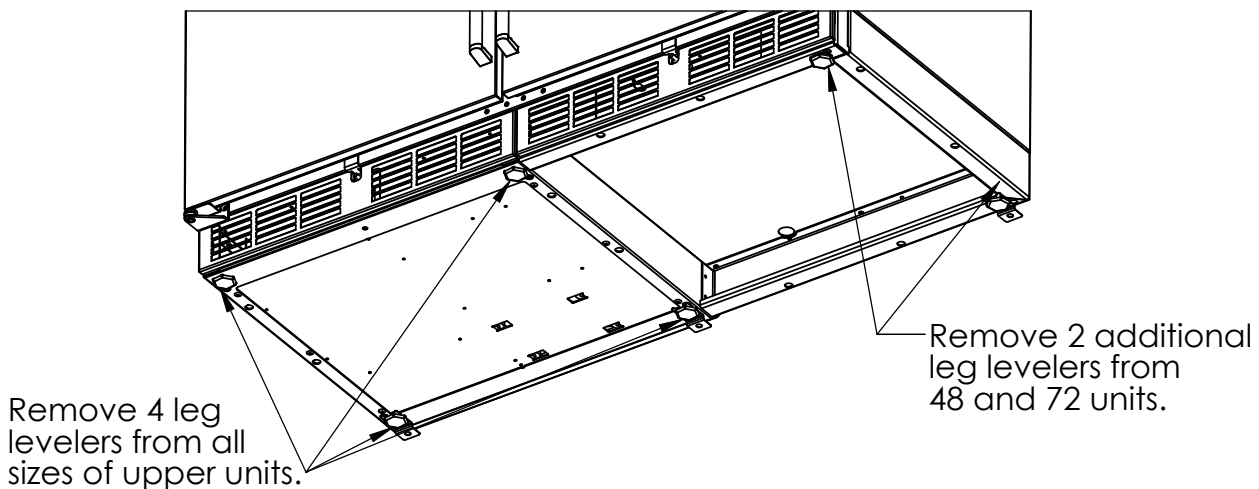

STACKING KIT INSTALLATION

Step 3: Attach mounting plate (where the leg levelers were removed in step 2) by using 1/4-20 machine screws. Flange should be pointing away from the bottom of the unit.

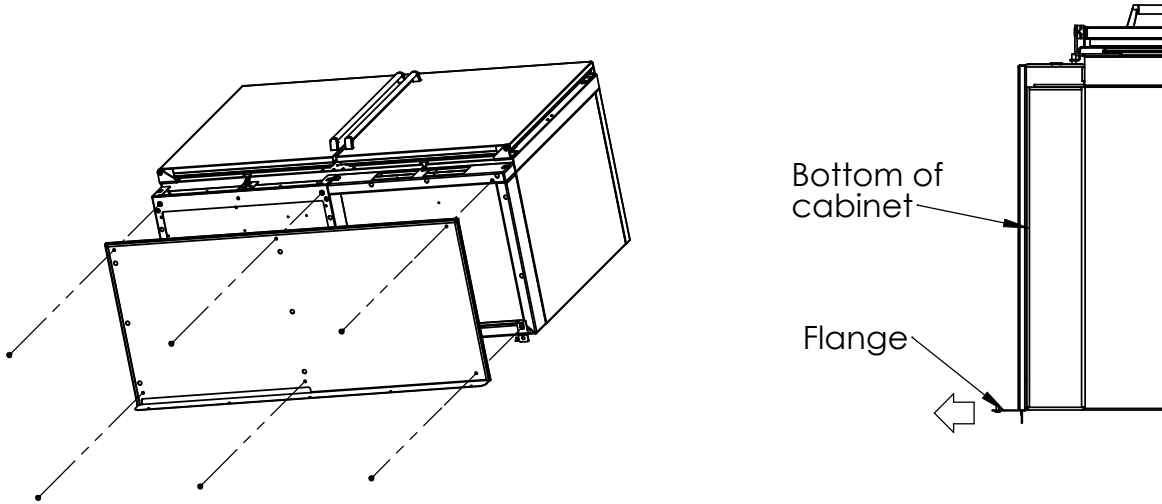

Step 4: Place upper unit on top of lower unit and attach using #10 sheet metal screws (where the rivets were drilled out in step 1).

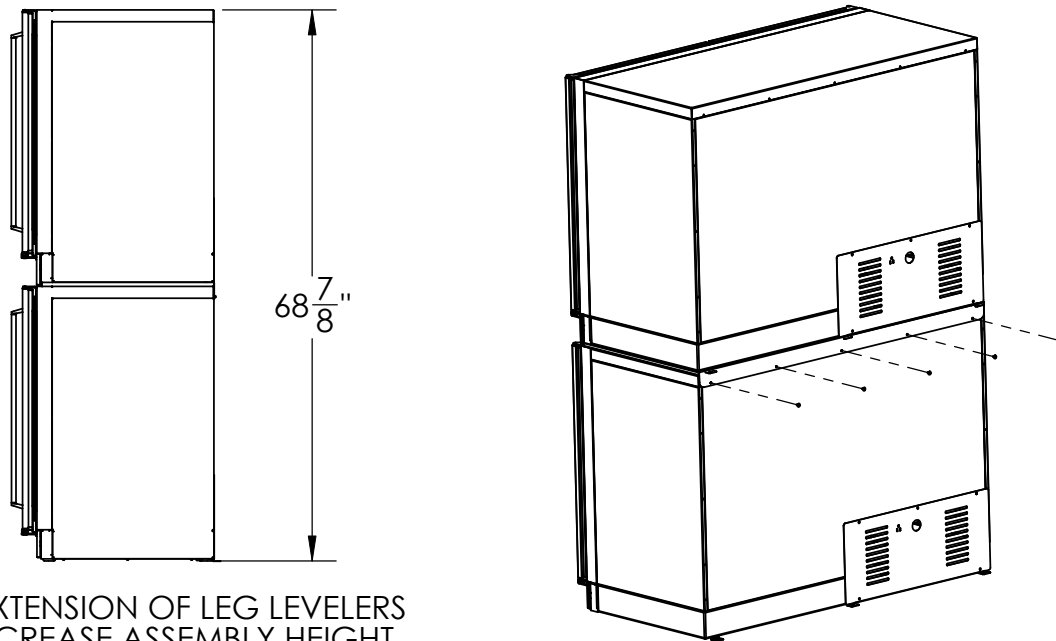

NOTE: EXTENSION OF LEG LEVELERS
WILL INCREASE ASSEMBLY HEIGHT



STACKING KIT INSTALLATION

Step 5: Attach -4- bumpers and -2- latch strikes to each new grille.
Orient tabs vertically. Attach grille assembly to upper unit.
Move stacked assembly into final position by pushing lower unit.

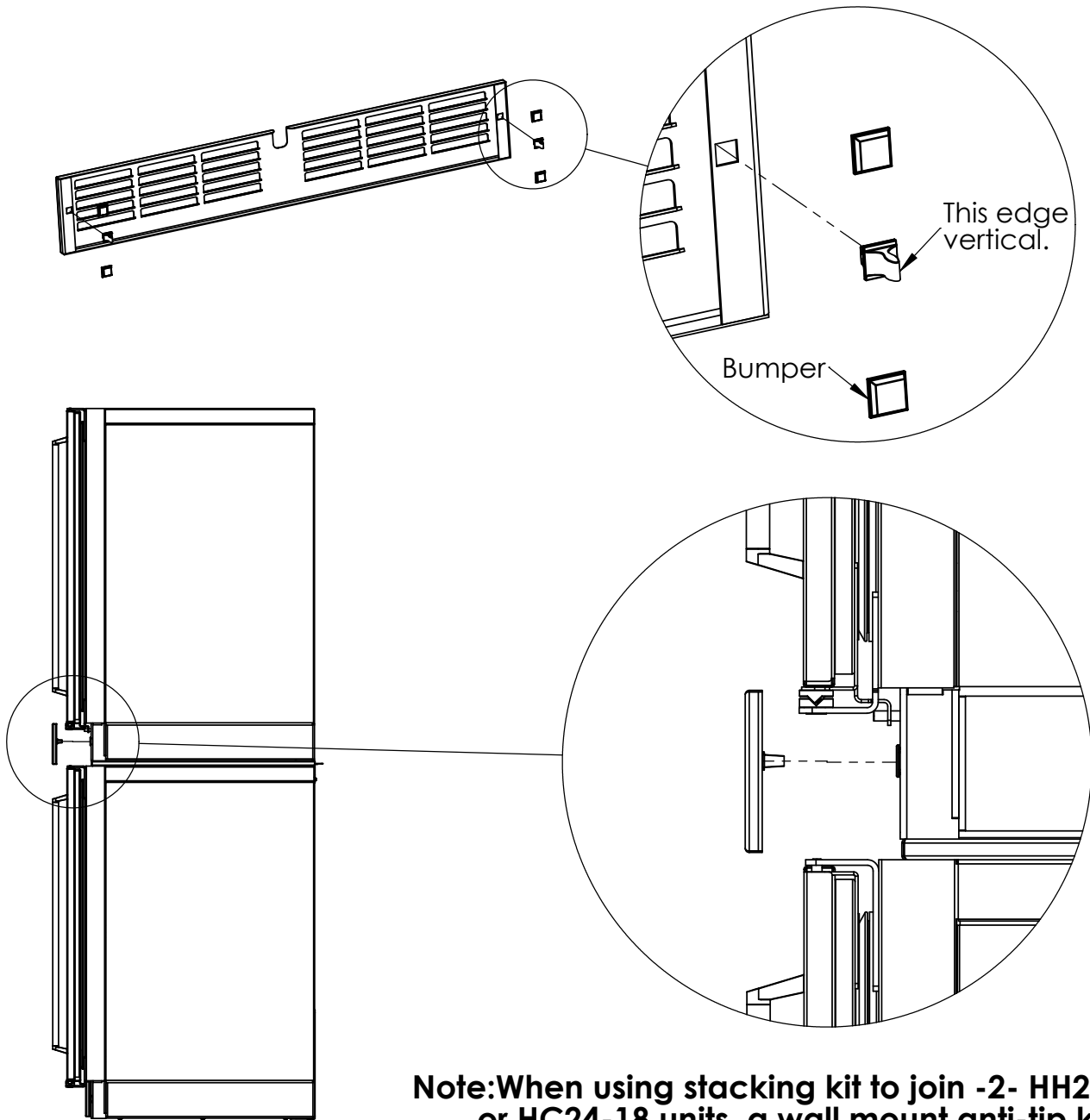

Note:When using stacking kit to join -2- HH24 or HC24-18 units, a wall mount anti-tip kit must be installed. See cabinet manual for instructions.

