

# INSTALLATION AND OPERATION INSTRUCTIONS PERLICK BATCH ROTARY GLASSWASHERS

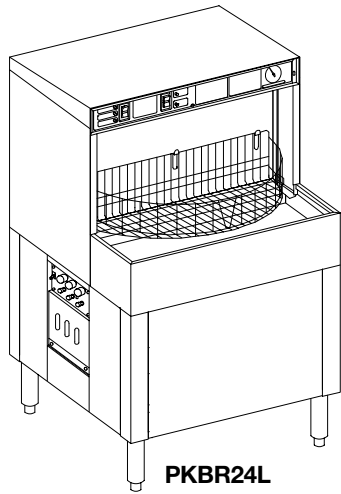

PKBR24L

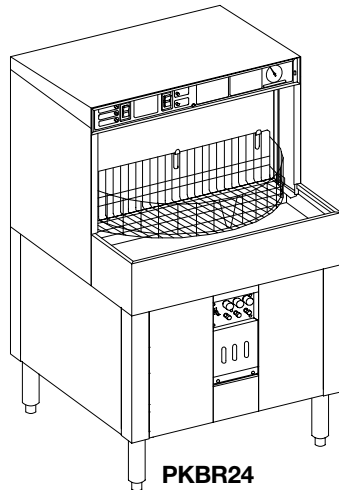

PKBR24

## MODEL NOS.

- PKBR24
- PKBR24L
- PKBR24R



## IMPORTANT INFORMATION

This manual has been prepared to assist you in the operation of the Perlick Batch Rotary Glasswasher.

We dedicate considerable time to ensure that our products provide the highest level of customer satisfaction. If service is required, your dealer can provide you with a list of qualified service agents. For your own protection, never return merchandise for credit without our approval.

We thank you for selecting a Perlick product and assure you of our continuing interest in your satisfaction.

## Table of Contents

<b>Warranty Information</b> .....	2
<b>Specifications</b> .....	3
<b>Chemical Specifications</b>	
Water Conditioning.....	4
Chemical Concentrations.....	4
<b>Start-Up Procedures</b>	
Before Starting the Glasswasher .....	5
Starting the Glasswasher .....	5
Priming the Chemical System.....	5
Operational Testing .....	5
Installing Chemical Squeeze Tubes .....	6
Priming the Chemical Pumps.....	7
Setting the Chemical Controls .....	7
<b>Owners Instructions</b>	
Component Identification.....	8
Instrument Panel .....	9
Operating the Glasswasher.....	9
Washing Glasses.....	9
Chemical Control Panel .....	10
<b>Maintenance and Troubleshooting</b>	
End of Day Shutdown .....	11
Deliming.....	11
Troubleshooting.....	11
Machine Operation & Cycle Sequence.....	12
Replacement Parts.....	13
Electrical Connection Diagram.....	14
Adjusting Chemical Concentrations.....	15
Calibrating the Chemical System.....	15



# Warranty Information

## **ONE YEAR LIMITED WARRANTY**

The Perlick Corporation warrants its glasswasher to be free from defects in material and workmanship, under normal use and operation, for a period of one (1) year from the date of initial start-up or eighteen (18) months from the date of shipment from the factory, whichever comes first. Perlick® will repair or replace, at our option, during the warranty period, any part that may be defective in material and/or factory workmanship. This warranty is conditioned upon the customer's maintenance and care as outlined in the service manual and the return of the warranty registration card. Warranty repairs will be performed, free of charge, during Perlick's® authorized service agency's normal business hours. Should the customer require after hours service, it is the customer's responsibility for any overtime premium. Machine is warranted only for the initial place of installation. Removal of machine automatically terminates this warranty.

Perlick® shall have no liability under this warranty unless the customer promptly notifies Perlick® or its factory authorized service agent of any alleged defects. All defective parts become the property of Perlick® and must be returned to Perlick®, or its agent, at Perlick's® expense, within thirty (30) days from the date of the part's replacement. Parts replaced within the warranty carry only the unexpired portions of the machine's warranty. Not covered by this warranty are changes (parts and/or labor) necessitated by or damage resulting from: water conditions, accident, alteration, improper use, abuse, tampering, improper installation or failure to follow operating and maintenance procedures. Examples of the foregoing, but without limitations are:

- 1) Damage to machine resulting from excessive concentrations of chlorine or deliming acid solutions;
- 2) Use with utilities other than designated on the glasswasher I.D. plate or owners manual;

- 3) Improper connection of utility services;
- 4) Inadequate or excessive water pressure;
- 5) Leaks caused by faulty installation;
- 6) Component failures caused by water leaks due to faulty installation;
- 7) Failure to comply to national and/or local codes;
- 8) Failure due to deposits resulting from hard water, detergents, chlorines, delimers, or improper maintaining;
- 9) Resetting breakers or fuse replacement;
- 10) Adjustments such as thermostats and chemical pump system;
- 11) Improper opening of utility supply valve;
- 12) Cleaning drain valves, line strainer, spray nozzles, etc.;
- 13) Improper installation or malfunction of chemical dispensing equipment supplied by others;
- 14) Failure to provide regular and/or daily maintenance and cleaning as outlined in this owners manual.

THIS WARRANTY IS LIMITED TO GLASSWASHERS INSTALLED WITHIN THE 48 CONTINENTAL UNITED STATES AND CANADA. IN ALASKA, HAWAII AND ELSEWHERE OUTSIDE THE CONTINENTAL U.S. AND CANADA, THIS WARRANTY IS LIMITED TO REPLACEMENT PARTS ONLY.

THERE ARE NO OTHER WARRANTIES, EXPRESSED OR IMPLIED, MADE BY THE PERLICK CORPORATION FOR ITS GLASSWASHER, INCLUDING ANY IMPLIED WARRANTY OF MERCHANTABILITY OR FITNESS FOR A PARTICULAR PURPOSE AND IN LIEU OF ALL OTHER OBLIGATIONS OR LIABILITY ON THE PART OF PERLICK®, INCLUDING LIABILITY FOR INCIDENTAL OR CONSEQUENTIAL DAMAGES OR FOR LOSS OF PROFITS OR GOODWILL. NO OTHER WARRANTIES ARE AUTHORIZED ON BEHALF OF PERLICK®.

### **RECORD THIS INFORMATION**

MODEL NO. \_\_\_\_\_

SERIAL NO.. \_\_\_\_\_

INSTALLATION DATE: \_\_\_\_\_



Perlick is committed to continuous improvement. Therefore, we reserve the right to change specifications without prior notice.

# Sizes and Specifications PKBR24 Glasswashers



MODEL NOS.	PKBR24	PKBR24L	PKBR24R
WASH TANK CAPACITY (gals.)	1	1	1
CYCLE TIME (sec.)	120	120	120
WASH TIME (sec.) 60	60	60	
SANITIZER TIME (sec.)	35	35	35
GLASSES WASHED PER HR. (2 1/2" dia.)	720	720	720
TANK HEATER (watts)	650	650	650
WASH PUMP CAPACITY (gals./min.)	24	24	24
DRAIN FLOW (gals./cycle)	1.67	1.67	1.67
EXHAUST REQUIREMENT	None	None	None
MAXIMUM GLASS HEIGHT	10"	10"	10"
Ship wt lbs. (kg)	225 (103)	225 (103)	225 (103)
ELECTRICAL	120 Volt, 60 Hz., single phase AC. 5.4 amps, furnished with 6 foot power cord and standard 3 prong NEMA style 5-15P.		
PLUMBING	<p><b>Hot Water Inlet Connection:</b> 1/2" NPTM. Incoming Hot Water: 130–140° F, at 30-60 psi with a flow rate of 4.0 gal/min. Drain: 1 1/4 IPS PVC socket connection to include an air gap.</p> <p><b>Plumbers Hookup Kit:</b> Includes water hammer arrestor, stop valve and union. <b>Important:</b> Failure to install the Glasswasher with Plumbers Hookup Kit can damage the hot water solenoid valve. <i>Machine failure due to improper installation is not covered by Perlick's warranty.</i></p>		
WATER HARDNESS	Water containing more than 15 GPG will require a water softener. <b>Caution:</b> Parts failure caused by hard water are not covered under <b>Perlick's warranty.</b>		
DETERGENT, SANITIZER and RINSE AID	<p><b>Detergent:</b> A heavy-duty liquid warewashing detergent containing water conditioners.</p> <p><b>Chlorine Sanitizer:</b> Any EPA registered chlorine can be used. The EPA marking can be found on the container label. <b>Rinse Aid:</b> A low-foaming warewashing rinse aid containing water conditioners. <b>Note:</b> <i>To ensure maximum glasswasher performance. It is important to select the appropriate detergent and rinse aid for specific water conditions. These chemicals can be purchased from a local chemical supplier or food service distributor.</i></p>		
OPTIONAL ACCESSORIES	<ul style="list-style-type: none"> <li>• Low Sanitizer shut down kit - #61945</li> <li>• Glass Rack - #50470-2</li> </ul>		

All plumbing and chemical lines must be routed so that the glasswasher can be pulled out for service.

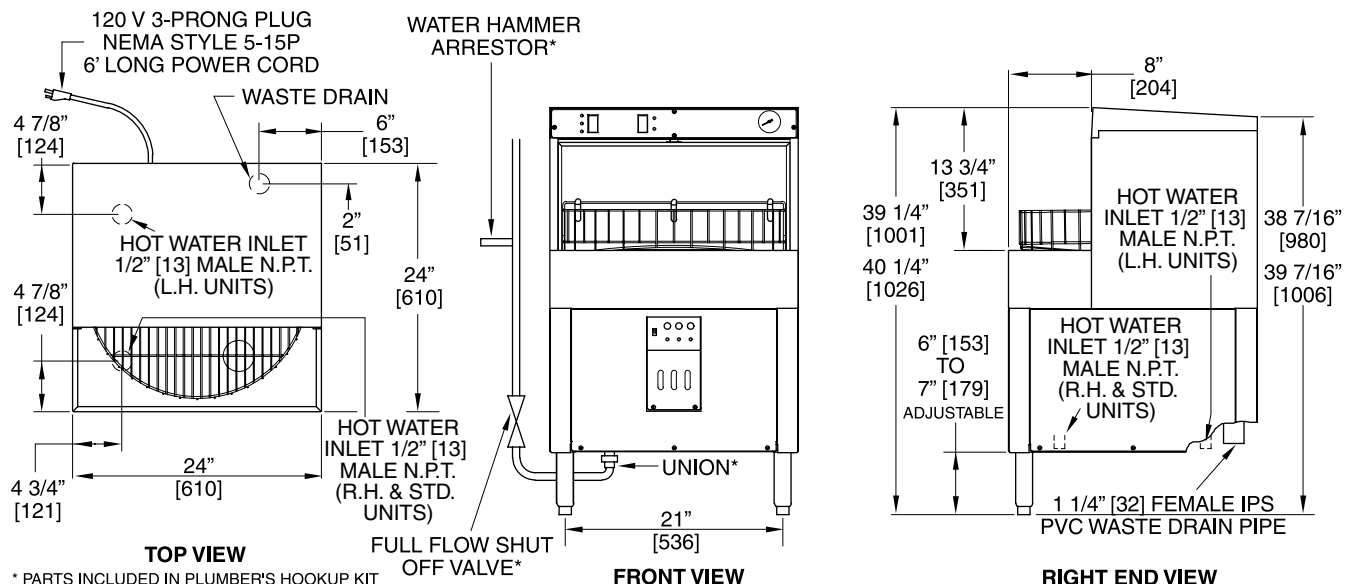

# Chemical Specifications

---

## Water Conditioning

---

- If the water you will use in the glasswasher is too hard, the glasswasher will not clean and sanitize glasses properly. Water contains dissolved calcium/lime which makes water "hard." Water can be conditioned mechanically by using a water softener or chemically by using a detergent and rinse aid which contains water conditioners. If the water you will use in the glasswasher is not properly conditioned, the glasswasher will:
  - Require frequent deliming.
  - Cost more to operate (higher chemical usage).
  - Shorten machine life.

Water Hardness GPG (Grains Per Gallon)	Type of Water Treatment required
0 - 5 GPG	Chemicals containing <b>Low</b> water conditioners
6 - 10 GPG	Chemicals containing <b>Medium</b> water conditioners
11 - 15 GPG	Chemicals containing <b>High</b> water conditioners
15 GPG Plus	Water softener required and chemicals containing <b>Low</b> water conditioners

Water with more than 15 GPG will require a water softener. It cannot be conditioned economically with chemicals. Failure of parts caused by hard water are not covered under the warranty.

## Chemical Specifications

---

### DETERGENT:

Heavy-duty, liquid warewashing detergent with water conditioners.

### SANITIZER (CHLORINE):

EPA registered, non-foaming liquid chlorine.

### RINSE ADDITIVE:

Low-foaming, warewashing rinse additive.

## Chemical Concentrations

---

### DETERGENT

Start the glasswasher and wait for 30 seconds into the wash cycle. Then stop the machine; take a sample and test for active alkalinity. It should be 250 ppm. +10%.

### SANITIZER

Run the glasswasher through a complete cycle. Take a sample and test it for chlorine concentration. It should be 50 ppm. minimum.

### RINSE ADDITIVE

There is no minimum concentration. Visually check the glassware for satisfactory wetting.



# START UP PROCEDURES

---

## Important

---

When an indicated function does not occur, corrections MUST be made before proceeding. No steps in a procedure should be ignored or omitted.

## Before Starting The Glasswasher

---

### CHECK TO DETERMINE IF...

- Water and Power are ON to glasswasher.
- Chemical System Power Switch is ON.
- Chemicals (detergent, sanitizer, and rinse aid) have been purchased and are on site for use.
- Chemical line drop tubes are in appropriate containers:
  - **RED** line into the detergent container.
  - **WHITE** line into the sanitizer container.
  - **BLUE** line into the rinse additive container.

### REMOVE...

- All protective paper from the front of machine.
- Shipping block from under the lower spray arm.

### INSTALL...

- Both glass racks onto the divider.

## Starting The Glasswasher

---

### PLACE...

- Power/drain (on-off drain) switch to ON.

### CHECK...

- Water level inside the tank (Level should be at top of overflow tube.)

## Priming The Chemical System

---

The chemical system prime buttons are located in the chemical control panel. Each of the three chemical systems must be primed separately.

- Press the prime button until the chemical is observed in the flow indicator window.
- Continue to press the prime button for an additional 15 seconds to complete the priming.
- Repeat procedure until all three systems have been primed.

## Operational Testing

---

### PRESS

- Wash switch to run the glasswasher through a complete cycle.

### CHECK

- That only the power and washing lights are illuminated while the machine is washing.
- That only the power and cycle complete lights are illuminated when cycle is finished.
- That the cycle complete light goes out when divider is rotated.

# START UP PROCEDURES

## Installing The Chemical Squeeze Tubes

When an indicated function does not occur, corrections MUST be made before proceeding. No steps in a procedure should be ignored or omitted.

### Important

The detergent, sanitizer, and rinse aid squeeze tubes must be installed before operating the glasswasher. Glassware will not be properly washed or sanitized unless these tubes are installed.

1. Remove the front panel and the chemical control panel, exposing the three chemical pumps.
2. Confirm water and power are on.
3. Place power switch to ON. Glasswasher fills for 25 seconds.
4. **IMPORTANT:** Install squeeze tubes, one at a time, to avoid possible mixing of components during reassembly. Although the components appear to be identical, they are not. If the entire housing is removed, it must be reinstalled in exactly the same position to avoid stripping the spider.
5. Remove 4 nylon nuts from pump head. To remove the pump cover without removing the entire

assembly, place a finger on the spider and pull the cover straight off of the four mounting studs.

Note: The roller has A & B engraved on its interior. It has also been color coded on the spider. Confirm the following:

Red .... A Position... Detergent.....Left Pump  
White.. A Position... Sanitizer (Chlorine) .....Middle Pump  
Blue.... B Position .. Rinse Aid .....Right Pump

6. Press the tube between the roller and housing. Caution: Using tools to push the squeeze tube in can result in damage to the tube. To make squeeze tube installation easier, use the prime button to rotate roller.
7. Replace the pump cover and nuts making sure pump cover is locked in position.
8. Repeat procedure for the two remaining pumps and replace the chemical control panel and front panel.

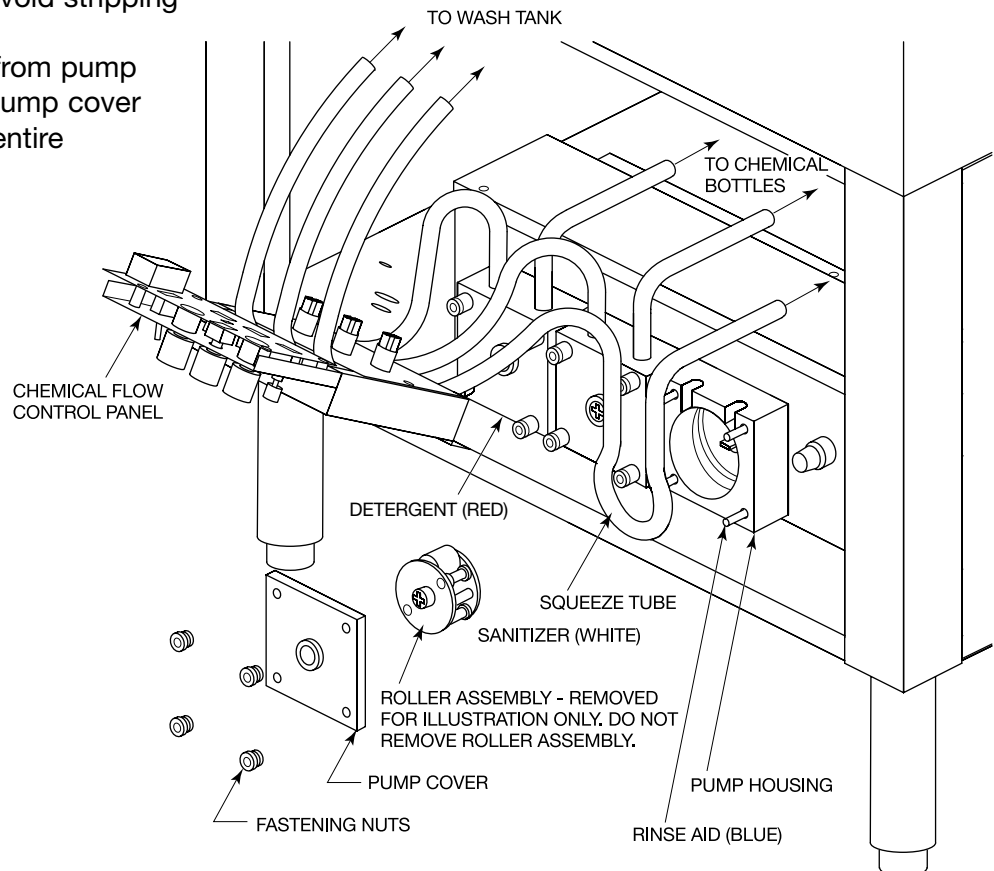

# START UP PROCEDURES

## Priming The Chemical Pumps

Place the chemical, detergent, chlorine, and rinse aid containers in a convenient location. Place appropriate drop tube into corresponding container as labeled on the drop tube.

- RedLine ..... Detergent Container
- White Line..... Sanitizer Container
- Blue Line..... Rinse Aid

Press and hold detergent prime button. Window will illuminate so that chemical flow can be observed. When chemical is observed, hold for an additional 15 seconds. This will allow the chemical to reach the wash tank area. Repeat procedure for Sanitizer and Rinse Aid.

## Setting The Chemical Controls

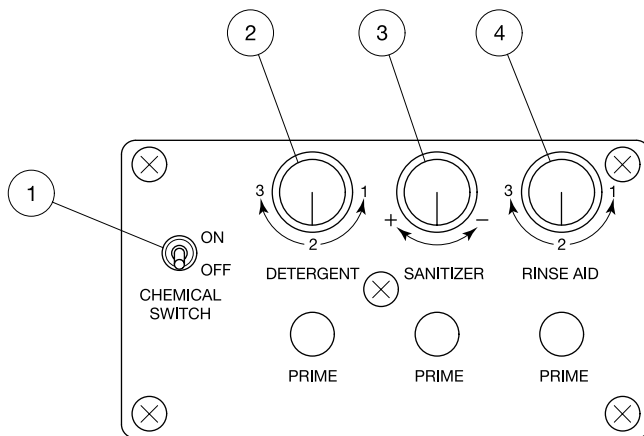

### 1. CHEMICAL SWITCH

This switch turns the chemical pump system on and off and will be used to delime the machine. The switch should be in the ON position.

### 2. DETERGENT CONTROL

Controls detergent concentration with three pre-calibrated settings:

- 1 = Lowest Concentration
- 2 = Medium Concentration
- 3 = Highest Concentration

Your water hardness, detergent strength and amount of water conditioners in the detergent will determine the final setting of this control. Start with the control on No. 1 and increase until the best cleaning result is achieved.

### 3. SANITIZER CONTROL

Controls chlorine concentration with an infinite adjustment. This control is set so that a minimum of 50 ppm. of chlorine is obtained. Use the chlorine test kit to set this control provided with the glasswasher. NOTE: This setting should be tested daily and must be adjusted according to local health standards.

### 4. RINSE AID

Controls rinse aid concentration with three pre-calibrated settings:

- 1 = Lowest Concentration
- 2 = Medium Concentration
- 3 = Highest Concentration

Your water hardness and the strength of the rinse aid used will determine the final setting of this control. Start with the control in the No. 1 position. If the water does not sheet on the glassware, and droplets are present, increase the concentration.

# OWNERS INSTRUCTIONS

## Component Identification

### 1 - LOWER SPRAY ARM:

Oscillates 120° to enable the fan-shaped spray to thoroughly clean and sanitize the interior of the glasses.

### 2 - TANK COVER SCREEN:

Located at the bottom of the wash area. Care should be taken to keep debris from entering the tank when the screen has been removed for cleaning.

### 3 - OVERFLOW TUBE:

Located in the wash tank. Drains overflow water.

### 4 - TANK FILTER:

Located within the tank. Care should be taken to keep debris from entering the wash system when the filter is removed for cleaning.

### 5 - UPPER SPRAY ARM:

A stationary arm located at the top of the wash compartment. The fan shaped spray cleans and rinses the exterior of the glasses.

### 6 - DIVIDER:

Holds two removable racks. The divider can be manually rotated in either direction, but must be parallel to the front of the machine before a wash cycle can begin. If the divider is rotated during a wash cycle, the machine will stop.

### 7 - CHEMICAL FLOW INDICATORS:

Located just below the chemical control panel. These windows illuminate while the chemical pumps operate, providing a visual indicator of the chemical flow.

### 8 - CHEMICAL CONTROL PANEL:

Located on the front panel. This panel contains all the user controls for the chemical system.

- Chemical control knobs control the chemical concentrations in the wash water
- The prime buttons allow the chemical lines to fill without having to run the glass washer.
- The chemical system power switch should be kept on during normal operation. This switch is turned off while the glasswasher is cleaned.

### 9 - GLASS RACK(S)

### 10 - INSTRUMENT PANEL

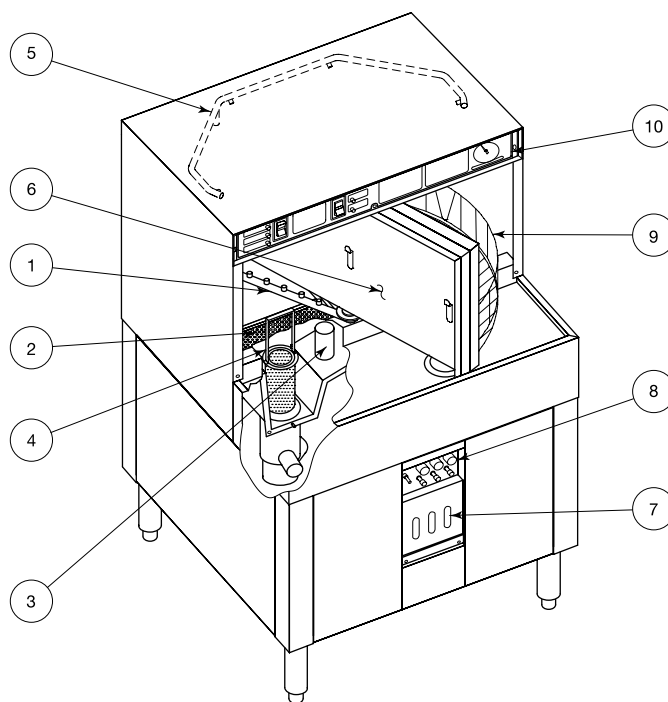

# START UP PROCEDURES

## The Instrument Panel

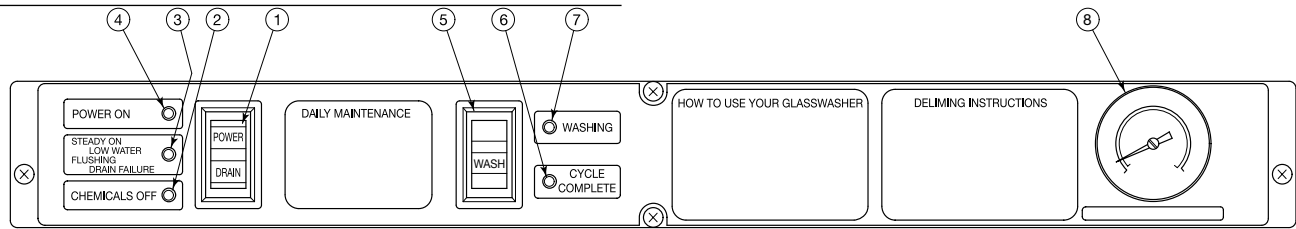

ITEM NO.	DESCRIPTION	FUNCTION
1	<b>POWER/DRAIN (On/Off Drain)</b>	<b>The Power/drain (on/off drain) switch</b> is a three-position rocker switch. <b>Center position:</b> Power is OFF; no lights are illuminated. <b>Upper position:</b> Power is ON and Power ON light is illuminated. Opens hot water solenoid for 25 seconds. <b>Lower position:</b> Machine is in the DRAIN* mode.
<p><b>* Note: Switch must be pressed for a minimum of ten seconds to drain the tank. The drain is activated for only as long as the switch is pressed.</b></p>		
2	<b>CHEMICALS OFF LIGHT</b>	Illuminated when the switch in the chemical control panel is in the OFF position.
3	<b>LOW WATER LIGHT</b>	<b>Steady Illumination:</b> Machine has stopped due to low water in tank. <b>Flashing:</b> Drain failure.
4	<b>POWER ON LIGHT</b>	Illuminated when the power is ON.
5	<b>WASH SWITCH</b>	Initiates a wash cycle when pressed.
6	<b>CYCLE COMPLETE LIGHT</b>	Illuminated when the wash cycle is complete and divider is ready to be rotated.
7	<b>WASHING LIGHT</b>	Illuminated when the machine is in the wash cycle.
8	<b>THERMOMETER</b>	Indicates water temperature inside tank. Operating temperature should be 130-140° F.

## Operating The Glasswasher

- Water temperature (No. 8) should be between 130-140° F. to assure proper glass washing. Open a hot water faucet in the bar area to ensure that adequate hot water is coming to the glasswasher.
- Press Power Switch (No.1.) Yellow Power On Light (No. 4) comes on and wash tank fills with water for 25 seconds. If the red Low Water Light comes on, this indicates that incoming water pressure or flow is not adequate. Contact Perlick or your authorized service agency.

## Washing Glasses

- The glasswasher is provided with two vinyl-coated racks which hang on each side of the divider. Racks are removable for easy loading and unloading of glassware.
- Place EMPTY glasses on glass rack, open end down. (Maximum glass size is 10".) Solids which are dumped into the glasswasher (i.e., napkins,

- straws, sticks, fruit rinds, etc.) will significantly affect the glasswasher's performance and time needed for daily cleaning. Poor performance due to poor cleaning is not covered by manufacturer's warranty.
- Rotate loaded rack 180° into the wash area.
- Depress Wash Switch (No. 5.) the yellow Washing Light (No. 7) comes on initiating a two minute wash cycle. Never rotate divider until Cycle Complete light is illuminated. This action terminates the wash cycle and then the glassware will not have been properly washed and/or sanitized.
- When the yellow Cycle Complete light comes on, this indicates that the glasses in the wash area have been washed and sanitized. Rotate the divider 180 degrees to gain access to clean glasses. Yellow Cycle Complete light will go off and the next load of dirty glasses is ready to be washed.
- Drain excess water from glass sumps by lifting the front edge of the glass rack.



# OWNERS INSTRUCTIONS

## Chemical Control Panel

ITEM NO.	DESCRIPTION	FUNCTION
1	<b>CHEMICAL SYSTEM POWER SWITCH</b>	Should be kept in the ON position except during cleaning. When switch is in the OFF position, the Chemical OFF light on the instrument panel will be illuminated.
2	<b>DETERGENT CONTROL KNOB</b>	Controls detergent concentration with three, pre-calibrated settings: 1 = Lowest Concentration 2 = Medium Concentration 3 = Highest Concentration
3	<b>SANITIZER CONTROL KNOB</b>	Controls sanitizer concentration with an infinite adjustment to precisely dispense sanitizer to the required minimum of 50 ppm.
4	<b>RINSE ADDITIVE CONTROL</b>	Controls rinse aid concentration with three, pre-calibrated settings: 1 = Lowest Concentration 2 = Medium Concentration 3 = Highest Concentration
5	<b>PRIME SWITCHES</b>	Fills chemical lines without running glasswasher. Power ON light must be illuminated.
6	<b>CHEMICAL FLOW INDICATORS</b>	These windows illuminate when a chemical is flowing during a wash cycle or when chemical lines are being primed, providing a visual indicator of chemical flow.

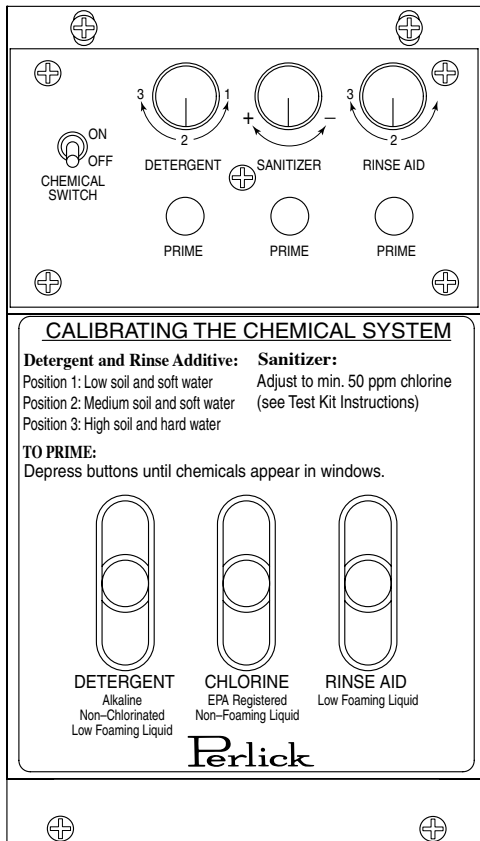

Perlick is committed to continuous improvement. Therefore, we reserve the right to change specifications without prior notice.

# MAINTENANCE AND TROUBLESHOOTING

---

## End of day Shutdown

---

Clear glassware from racks. Press lower portion of Power/Drain (on-off drain) switch for ten (10) seconds to drain tank. Place Power/drain (on-off drain) switch to off. We recommend that solid wastes be removed from the load and unload area at least once each day to ensure optimum performance.

## Deliming

---

Prolonged hard water use may cause a white film to appear on the inside surface of the wash area. It is then necessary to delime the machine.

1. Remove all glassware from racks, and any debris from the load and wash areas.
2. Chemically charged water must be drained from the tank. Press the lower portion of Power/drain (on-off drain) switch for 10 seconds.
3. Place the chemical system Power Switch to OFF.
4. Refill the tank by placing the Power/drain (on-off drain) switch to ON. (Power ON and chemical OFF lights illuminate.)
5. Add delimer to wash area. Use amount recommended on container.
6. Press Wash Switch. (Washing light does not illuminate in cleaning mode.)
7. While the machine is running, clean the load area and exterior of the machine with a damp cloth and wipe dry. Replenish chemicals if required. See warning!
8. Press the lower portion of Power/drain (on-off drain) switch for 10 seconds to drain tank.
9. To restore service, place chemical Power Switch to ON.
10. Place Power/drain (on-off drain) switch to ON. The glasswasher is now ready to use.

## WARNING

**Always protect skin, eyes, and mucous membranes when working with chemicals. Always clean up chemical spills immediately. At full strength the chemicals used in your glasswasher can cause severe burns and metal corrosion. Do not mix with anything but water. Never intermix one with the other. Hazardous vapors may result. Keep out of the reach of children. See manufacturers label for complete instructions.**

## Troubleshooting

---

SYMPTOM	PROBABLE CAUSE
<b>Machine Does Not Operate</b>	Circuit breaker tripped. Power/drain (on-off drain) switch off. Divider not parallel with front of glasswasher. Water supply turned off. Electrical cord unplugged.
<b>Glasses Not Clean</b>	Incoming water temperature too low. (Required water temperature 130-140° F.) Detergent setting too low. Tank filter plugged.
<b>Machine Shuts Down</b>	Water supply turned off. (Low Water Light On) Incoming water supply insufficient. (4 gallon per minute flow rate required.)
<b>Flashing Low Water Light</b>	This indicates a drain failure. Call your service agency.

# MAINTENANCE AND TROUBLESHOOTING

## Maintenance Operation & Cycle Sequence

At the beginning of the wash cycle, the water in the tank is charged with detergent. After the cycle is completed, the detergent water is dumped down the drain. The sanitizing rinse cycle begins as the

tank is refilled with fresh water. Sanitizer and rinse additive is pumped into the tank. The rinse water is retained and will be used in the next wash cycle.

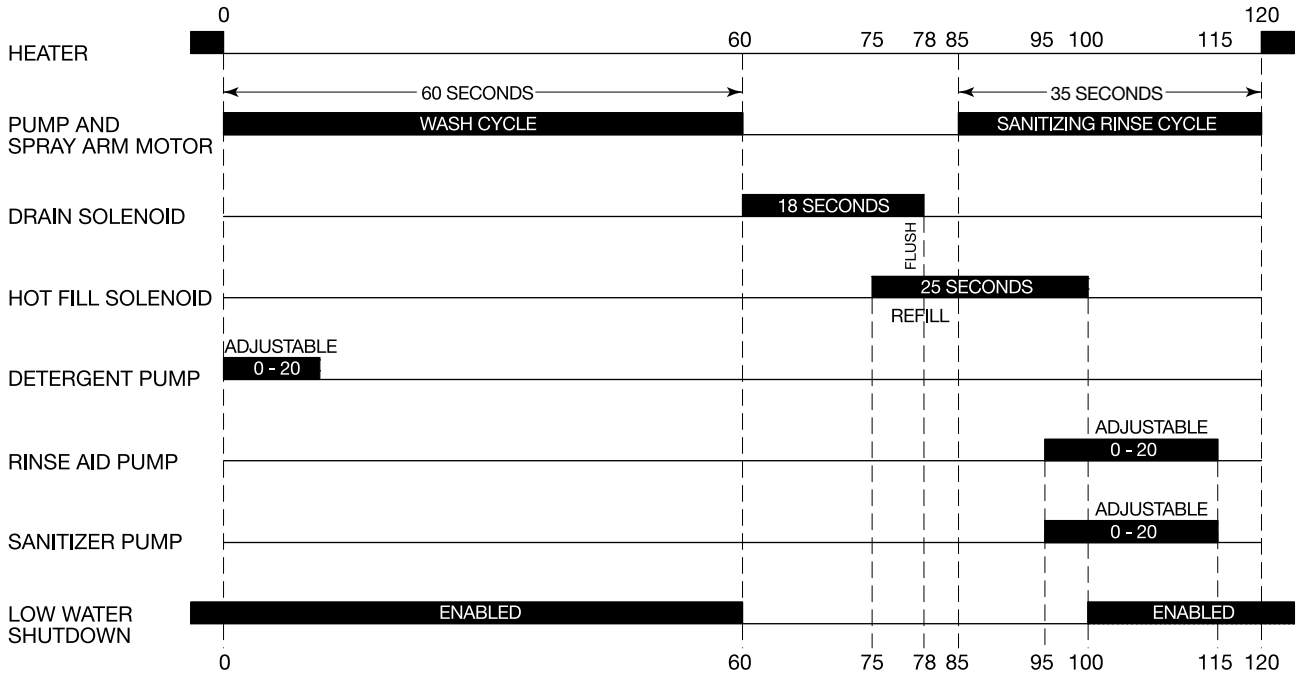

# MAINTENANCE AND TROUBLESHOOTING

## Replacement Parts

ITEM NO.	DESCRIPTION	PART NO.	ITEM NO.	DESCRIPTION	PART NO.
1	Glasswasher Control Kit	55042	18	Glass rack	50470-2
2	Spray arm drive motor	52536	19	Top divider seal	52692
3	Wash pump	50445	20	Top wash tank screen (For Serial Nos. to 443593 only)	50588
4	Pump motor capacitor	52528	20A	Top wash tank screen	R50614
5	Water inlet valve	52652-1	21	Chemical system control board	50453
6	Band heater	52669-1	22	Drain valve	50451
7	Rinse aid pickup tube assembly	52626A-B	23	Chemical system sight tube kit	52714A
	Detergent pickup tube assembly	52626A-R	24	Transformer	52566A
	Sanitizer pickup tube assembly	52626A-W	25	Temperature control	54153A
8	Divider side seal	52696	26	Fuse holder	54938-1
9	Wash water level switch	R54978-1		12 amp fuse	54939-1
10	Start/Wash switch	55003-1	27	Chemical pump gear motor	52537
11	Power/drain (on/off/drain) switch	55004-1	<b>PARTS NOT SHOWN</b>		
12	Red light	54809		Chemical bulkhead fittings	R54976
13	Amber light	54810		Amber chemical sight tube light	54790
14	Wash tank filter	52492		Flat strainer	54965-1
15	Safety switch - .250" quick connect	54995-1		Clean-out plugs for spray arms	R54900-1
16	Safety switch - .187" quick connect	54996-1		1/4" ID. chemical pump squeeze tube	52679-1
17	Roller bearing for divider lock	C12698-1		3/16" ID chemical pump squeeze tube	52681-1
				1/8" ID chemical pump squeeze tube	52680-1
				Seal kit	R54965

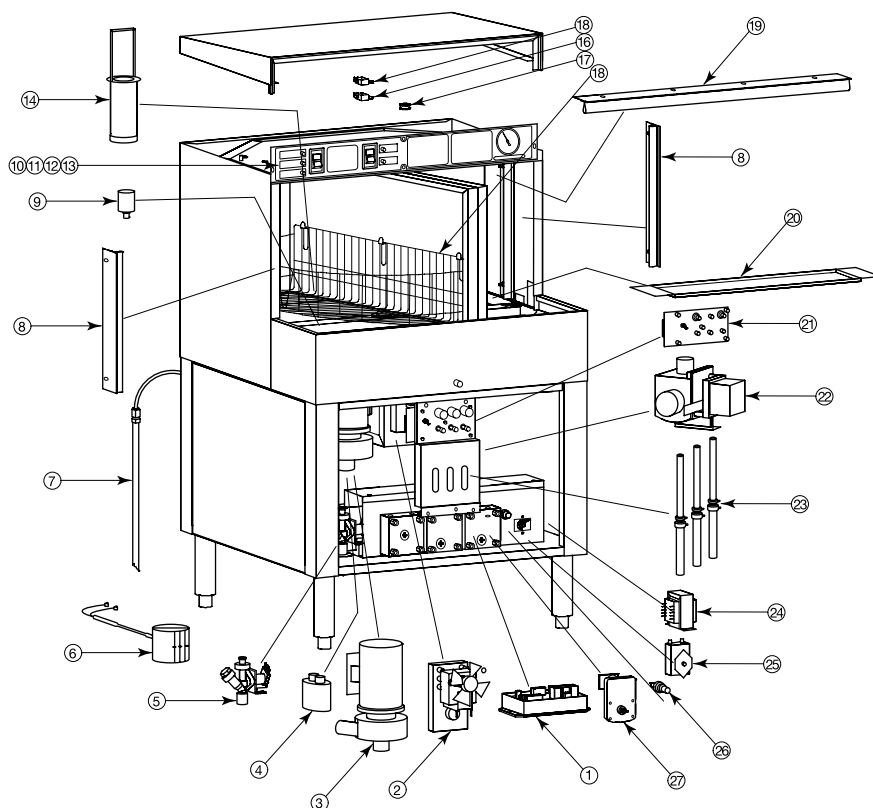



# MAINTENANCE AND TROUBLESHOOTING

## Adjusting Chemical Concentrations

### IMPORTANT NOTE:

Damage resulting from excessive chemical concentrations is not covered by warranty.

If adjustments are needed, the chemical control panel has adjustment knobs for the chemical concentrations in the wash water. The detergent and rinse aid knobs are three position switches controlling the run time of the chemical pump during a wash cycle. The sanitizer knob is a potentiometer controlling the speed of the sanitizer pump during a wash cycle. Factory calibrated times for these controls are as follows:

Detergent ..... Position #1 ..... 7 Seconds  
Position #2 ..... 10.5 Seconds  
(1 1/2 X Position #1)  
Position #3 ..... 14 Seconds  
(2 X Position #1)

Sanitizer ..... 12 Seconds regardless of the position of the control

Rinse Additive . Position #1 ..... 2 Seconds  
Position #2 ..... 4 Seconds  
(2 X Position #1)  
Position #3 ..... 8 Seconds  
(4 X Position #1)

If more adjustment is required, the chemical system must be recalibrated. See Chemical System Calibrating procedure.

## Calibrating the Chemical System

### IMPORTANT READ BEFORE BEGINNING

- Remove power cord from outlet.
- Remove lower front panel.
- Remove screws and remove cover to the electrical housing.
- Place Dip Switch 1 to the ON position. LED light will flash rapidly.
- Plug the glass washer in and place the Power/drain (on-off drain) switch to On.
- Place the detergent and rinse additive knob to the #1 position. The sanitizer can be calibrated with the sanitizer knob in any position.

### IMPORTANT NOTE:

#### CALIBRATE ONE PUMP AT A TIME.

Calibrating the pumps sets the time that the pumps will run during a wash cycle. Twenty (20) seconds is the maximum run time on any setting.

- Depress and hold the prime button of the pump being calibrated for the time that is needed for the pump to run.
- Place Dip Switch 1 back to the OFF position.
- Confirm calibration of chemical system by following the chemical concentration test procedure.
- Replace electrical housing cover and replace lower front panel.
- Repeat above procedures for each chemical.

## ! WARNING !

Use extreme care, electrical box contains live wires.



8300 West Good Hope Road • Milwaukee, WI 53223 • Phone 414-353-7060 • Fax 414-353-7069  
Toll Free 800-558-5592 • E-Mail: [Perlick@Perlick.com](mailto:Perlick@Perlick.com) • [www.Perlick.com](http://www.Perlick.com)