

DSA SERIES MODELS

OWNER'S MANUAL



Be sure ALL operators read, understand and have access to this manual at all times.

PHONE: 603-225-6684
MAILING ADDRESS: P.O Box 501, Concord, NH 03302-0501
SHIPPING ADDRESS: 10 Ferry St., Concord, NH 03301
FAX: 603-225-8472
GENERAL INFORMATION: profits@perfectfry.com
CUSTOMER SUPPORT: service@perfectfry.com
WEB: www.perfectfry.com

©2013 PERFECT FRY COMPANY



L20-395 R2

TABLE OF CONTENTS

OWNERS RESPONSIBILITIES	1
REGULATIONS & RECYCLING	2
SAFETY FIRST	3
INSTALLATION	4
ELECTRICAL POWER SUPPLY	4
ELECTRICAL SPECIFICATIONS	4
PREPARE COUNTER-TOP AREA.....	5
UNPACK	5
ASSEMBLY	8
COOKING	14
CLEANING	15
DAILY MAINTENANCE.....	15
WEEKLY MAINTENANCE.....	15
PERIODIC MAINTENANCE	17
TIPS ON DEEP FRYING	18
OIL FACTS	19
OPERATING INSTRUCTIONS	22
STARTING UP.....	23
MANUAL MODE	23
PRESET TIMES.....	24
PRESET MODE.....	24
PRESET LOCKED MODE.....	25
RAPIDFRY™ MODE	25
RAPIDFRY™ 2GO.....	26
DUAL LOAD.....	27
COOKING TIME CORRECTION.....	28
OPEN DRAWER LID – PAUSED COOK CYCLE	28
STANDBY MODE.....	29
SHUTTING DOWN	29
USER DEFINED OPTIONS	30
BACKGROUND MENU - ACCESSING	31
CTS™ (COOK TIME SENSITIVITY).....	31
BACKGROUND MENU - MAP	31
OPTION CHANGES.....	36
CUSTOMIZING PRESETS	37
HELP	38
SYSTEM ERROR CONDITIONS	38
TROUBLE-SHOOTING TABLE.....	40
DECLARATION OF CONFORMITY	42
THE PERFECT FRY 1 2 3 WARRANTY	43

OWNERS RESPONSIBILITIES



It is the owner's responsibility to:

- Insure the PERFECT FRYER is properly maintained.
- Allow only properly trained personnel to operate, clean and maintain a PERFECT FRYER.
- Contact local authorities having jurisdiction to insure that the installation conforms to all local fire, building and health regulations.
- Insure that the model ready for installation matches the supply voltage.
- Insure that the main power supply is disconnected before the PERFECT FRYER is serviced.
- Insure that all safety devices are intact.
- Insure that a proper surface is provided for the PERFECT FRYER to sit on.
- Insure that proper clearances are kept.
- Return the PERFECT FRYER for recycling when it reaches end of life

REGULATIONS & RECYCLING

Installation of your PERFECT FRYER must conform to all local fire and health regulations and building codes.

The table below describes the standards that your PERFECT FRYER has been tested to and the corresponding listing marks.

STANDARD	DESCRIPTION	LISTING MARK
NSF 4	Commercial Cooking, Rethermalization, and Powered Hot Food Holding and Transport Equipment.	
EN60335-1	Safety of Household and Similar Electrical Appliances Part 1. General Requirements Amendment 8913 - October 1995 Amendment 9475 - May 1997	
EN60335-2-37	Safety of Household and Similar Electrical Appliances Part 2. Commercial Electric Deep Fat Fryers	
EN61000-6-1 EN61000-6-3	Electromagnetic Compatibility (EMC) – Emissions & Immunity for Light Industrial Environments	

The table below describes the recycling procedures for your PERFECT FRYER.

WEEE (Waste Electrical & Electronic Equipment) 2002/96/EC	When your PERFECT FRYER has reached end of life, please deliver the fryer to your local distributor. They will prepare and deliver the fryer for recycling to the WEEE collection system in your country. Most of the fryer's materials can be recycled. DO NOT DISPOSE OF THE FRYER IN MUNICIPAL WASTE!	
---	---	---

SAFETY FIRST



LIFTING & MOVING:

- Your PERFECT FRYER's gross shipping weight is 125 lb. (57 kg). Net weight = 110 lb. (50 kg).

DEEP FRYING:

- Cooking oil is very hot (350°F or 177°C). Hot oil can cause severe burns. **DO NOT TOUCH THE COOKING OIL UNLESS YOU ARE SURE IT HAS COOLED.**

HEATER MODULE:

- DO NOT DROP
- DO NOT IMMERSE IN WATER

CLEANING:

- **DO NOT OPEN DRAWER LID OR FRONT PANEL WHEN PRODUCT IS LOADING**
- Before cleaning fryer or removing oil, let fryer cool to 122°F (50°C). **DO NOT TOUCH HEATER MODULE, VAT OR OIL UNLESS YOU ARE SURE IT HAS COOLED.**
- Lubricate rails of shovel and bottom of drawer using an approved food grade grease or silicone lubricant

COOKING OIL MAINTENANCE:

- For sanitation and safety, we recommend that the cooking oil is replaced once a week, more often for higher volume usage. Use a commercial grade deep-fryer formulated cooking oil. **OLD OIL HAS A REDUCED FLASHPOINT. OLD OIL AND OVER-WET FOOD ARE PRONE TO SURGE BOILING.**

SERVICING:

- DISCONNECT THE POWER SOURCE BEFORE SERVICING THE FRYER. There is no need to unplug your PERFECT FRYER for normal cleaning or maintenance.

INSTALLATION

⚠ CAUTION Your PERFECT FRYER is NOT to be operated in North America as it not certified for those areas.

⚠ CAUTION A portable restaurant kitchen extinguisher is necessary as a safety precaution and should be located nearby.

⚠ CAUTION The procedures for operation and maintenance are contained in this manual. Perfect Fry Company LLC.. shall not be liable for injury or damage to property other than this fryer.

Electrical Power Supply

- Your PERFECT FRYER must be connected to a dedicated electrical circuit that meets your fryer's requirements (see table below).

⚠ CAUTION Improper Installation may damage the fryer and void your warranty

- If your PERFECT FRYER's plug does not fit your wall outlet receptacle, have an electrician install the appropriate NEMA receptacle within 4 feet of the fryer.
- See the manufacturer's label on your PERFECT FRYER for the electrical Model No. DSAXXX, then check off your Model Number.

Electrical Specifications

PERFECT FRY MODEL	VOLTS	AMPS	CIRCUIT AMPS	WATTS	NEMA NUMBER	NEMA RECEPTACLE
↓ Put a check mark <input checked="" type="checkbox"/> in the box beside the Model Number of your PERFECT FRYER.						
<input type="checkbox"/> DSA720	240	30.0	Minimum 30	7200		For use on an individual branch circuit rated 30A minimum. For supply connectors, use minimum no. 10 AWG wire (30A rated). This fryer must be properly connected to a grounded, dedicated 240 VAC single phase circuit according to local installation standards and codes.
<input type="checkbox"/> DSA570	240	24.0	Minimum 30	5700		For use on an individual branch circuit rated 30A minimum. For supply connectors, use minimum no. 10 AWG wire (30A rated). This fryer must be properly connected to a grounded, dedicated 240 VAC single phase circuit according to local installation standards and codes.
<input type="checkbox"/> DSA375	240	16.0	Minimum 20	3750		For use on an individual branch circuit rated 20A minimum. For supply connectors, use minimum no. 12 AWG wire (20A rated min). This fryer must be properly connected to a grounded, dedicated 240 VAC single phase circuit according to local installation standards and codes.
All models are single phase; 50/60 hertz.						

INSTALLATION (Continued)

Prepare Counter-top Area

Unpack

Clearances:

1" on sides
2" on back
0" on top

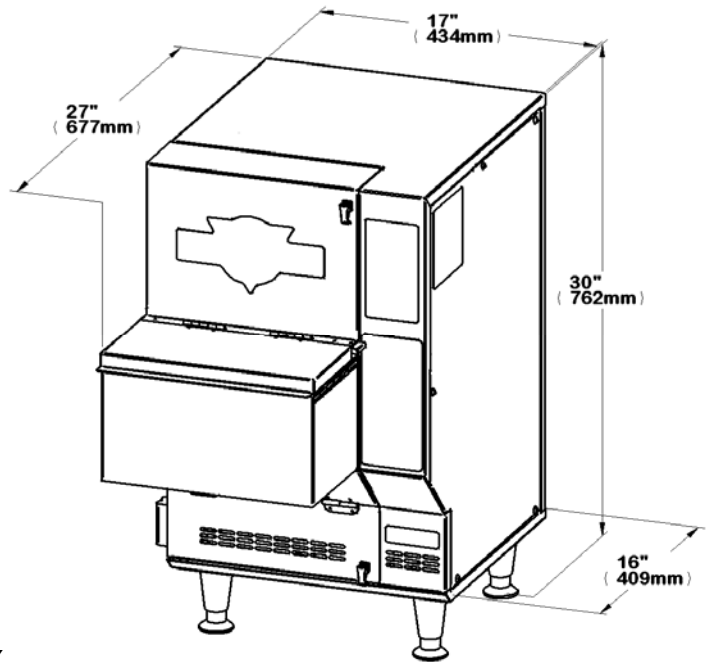

- 1) Cut straps on shipping box
- 2) Remove box top and body
- 3) Remove outer plastic wrapping and keep box along with foam corners and sides

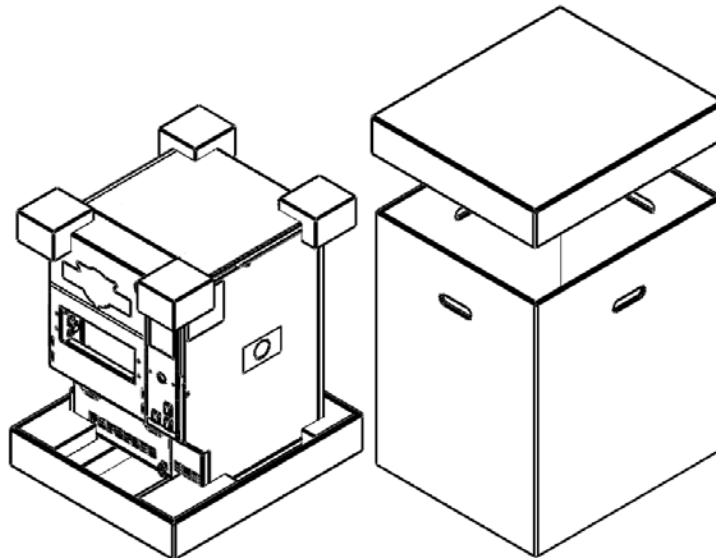

4) Remove all foam stuffing and parts

5) Put check mark in box once the part is removed

- 1** Air Filter Cage
- 2** Air Filter Cartridge
- 3** Basket
- 4** Heater Module
- 5** Oil Vat
- 6** Oil Spill Tray
- 7** Oil Hose
- 8** Legs (x4)
- 9** Front Panel
- 10** Shovel
- 11** Drawer Cover
- 12** Drawer Sleeve
- 13** Drawer Ramp
- 14** Heat Lamp
- 15** Basket Ramp
- 16** Basket Ramp Spring (x2)
- 17** Receiving Tray (not included)
4" high full size pan recommended

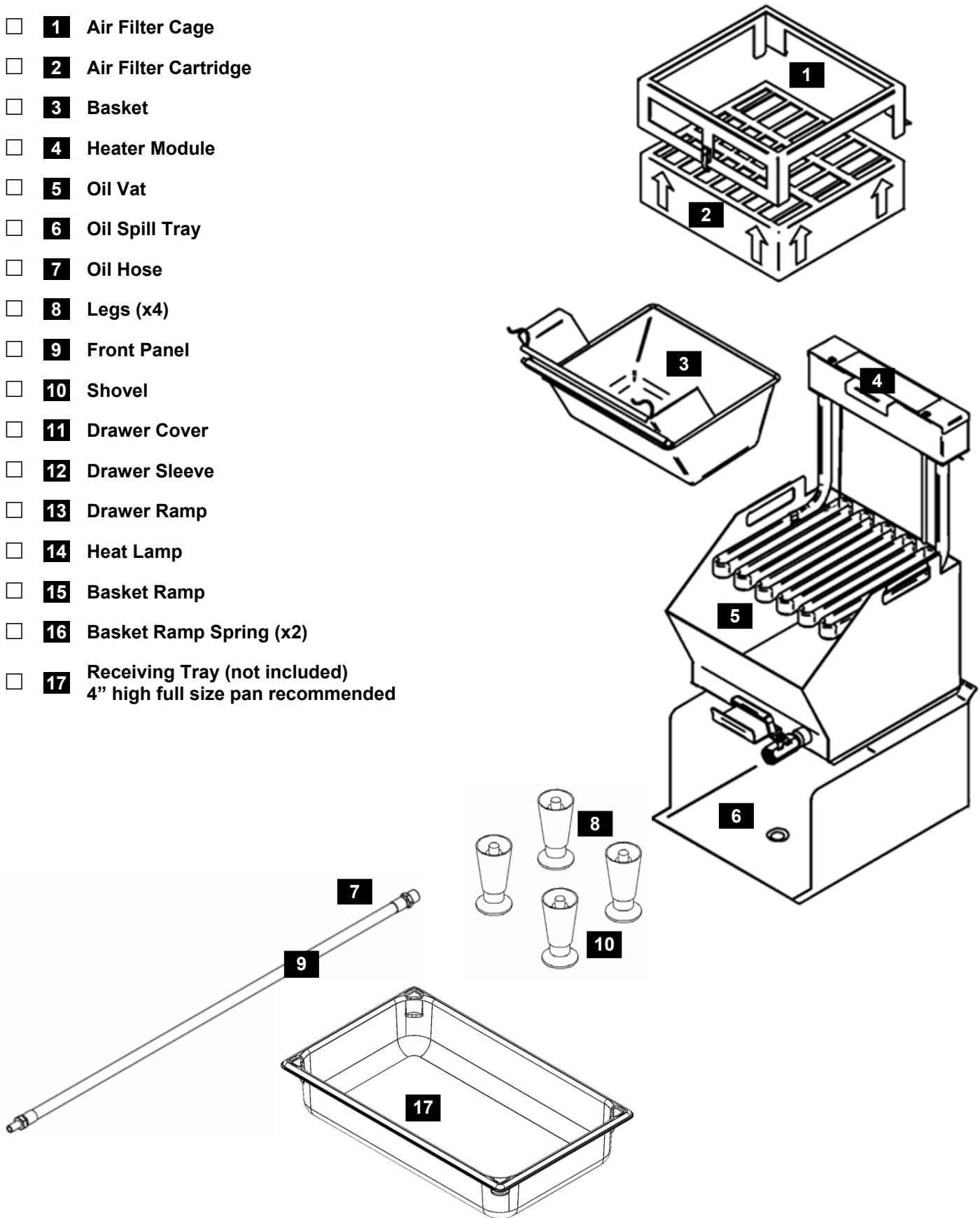

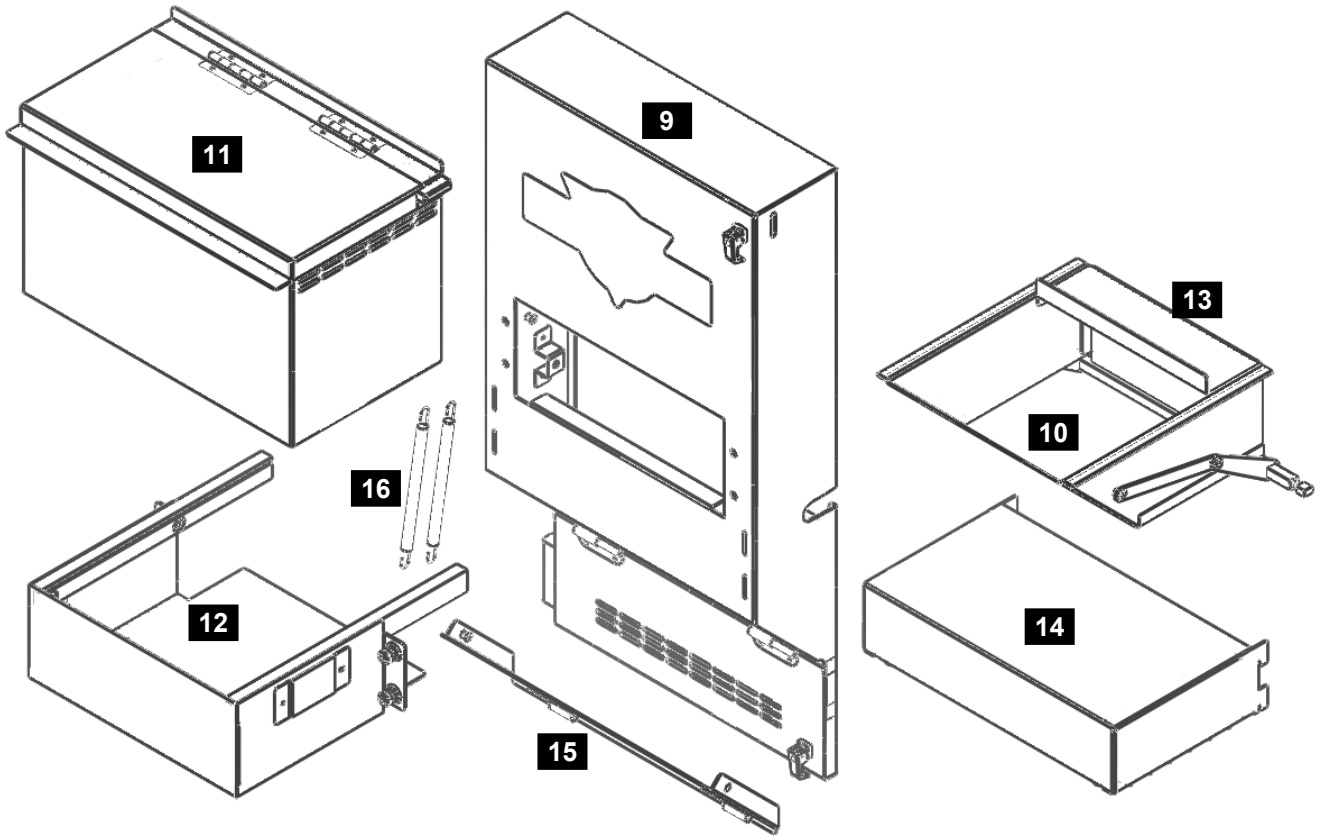

- 6) Tilt PERFECT FRYER to one side and install 2 adjustable legs, repeat process for other side

⚠ CAUTION Do not operate your PERFECT FRYER without legs.

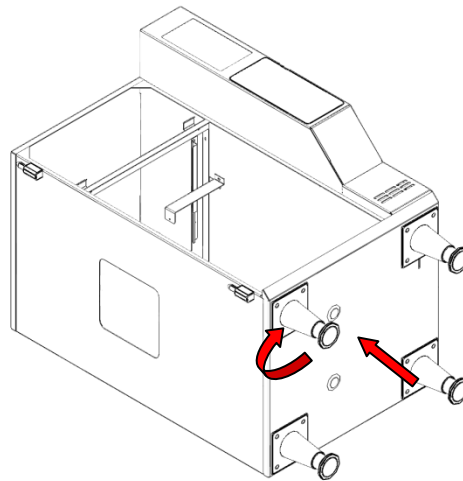

- 7) Lift your PERFECT FRYER onto countertop and adjust legs as necessary

⚠ CAUTION Your PERFECT FRYER weighs 110 lb. (50 kg). Lift it carefully with your legs or with the help of another person and place it in its final location.

- 8) Go to ASSEMBLY section (next page)

ASSEMBLY

1) Clean parts and inside of cabinet (all except air filter cartridge)

- a) Wash in warm soapy water
- b) Rinse with hot water
- c) Rinse with vinegar solution (1 part vinegar to 2 parts water)

⚠ CAUTION The heater box and heat lamp must NOT be immersed in water or other liquid.

2) Fit air filter cage over air filter cartridge

Note: Make sure arrows are pointing up

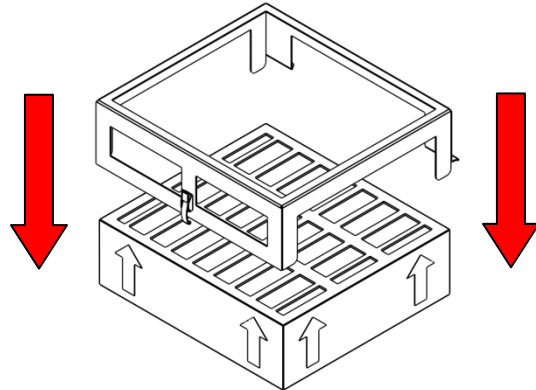

3) Slide air filter cartridge firmly back into filter compartment and fasten down with latch.

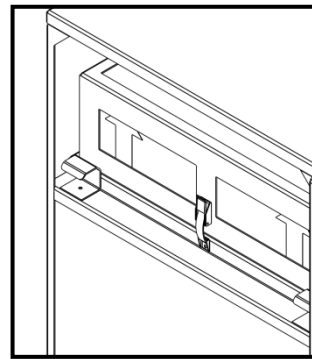

4) Install spill tray into bottom cooking compartment

Note: Indents on bottom of spill tray should fit into indents on bottom of cabinet

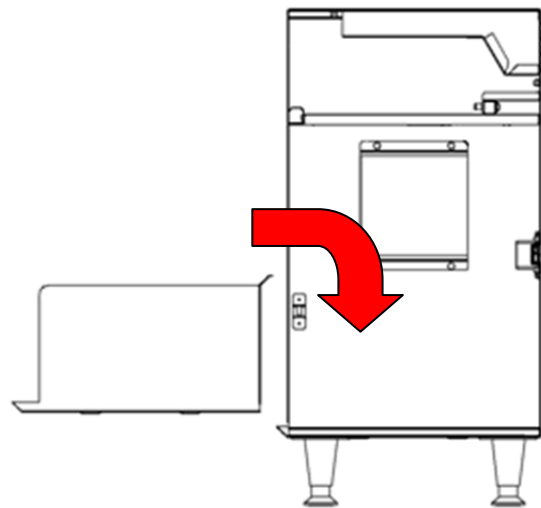

- 5) Set heater module onto vat

Note: “^” grooves on bottom of heater module should fit onto back of vat

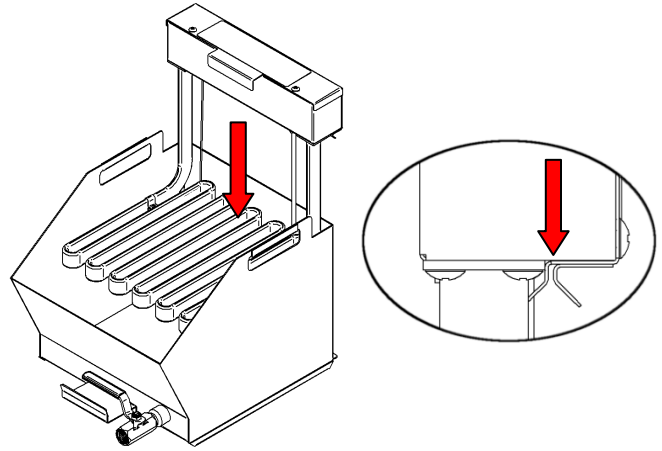

- 6) Pour frying oil into vat. Fill to **COLD** level mark. Use commercial grade deep fryer cooking oil. DO NOT OVERFILL.

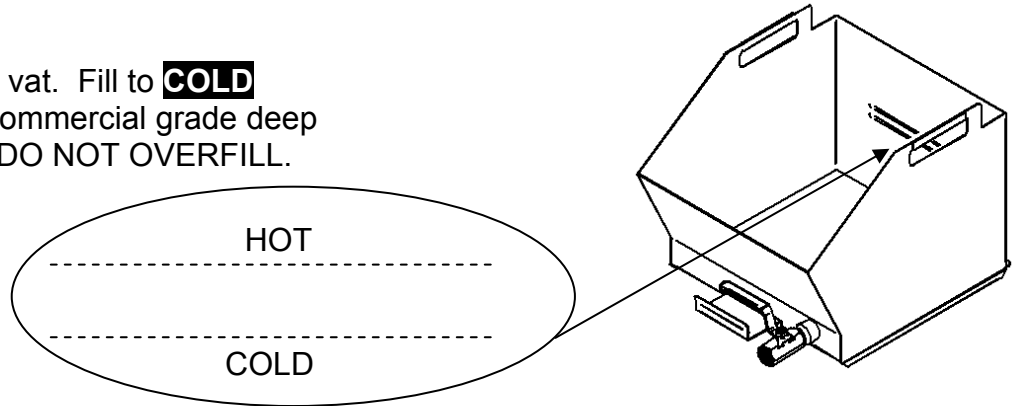

- 7) Slide heater module/vat into cooking compartment and push in all the way. Ensure electrical connection is complete with firm push on heater module.

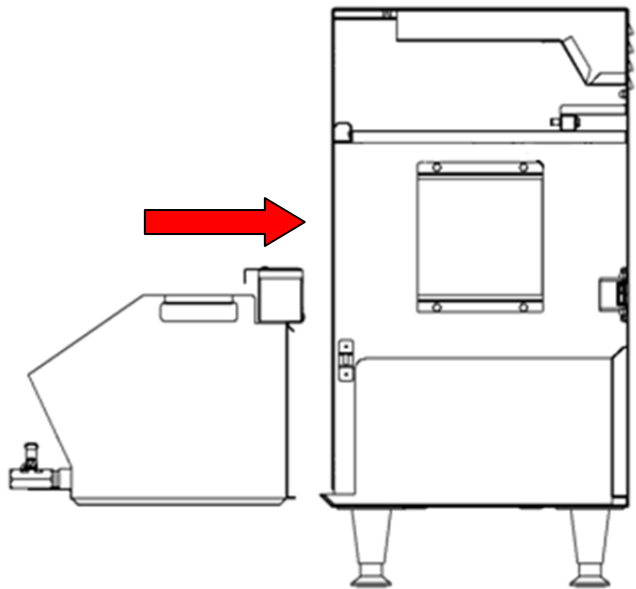

8) Install basket

- a) Tilt basket bottom forward and maneuver rod past cabinet flanges

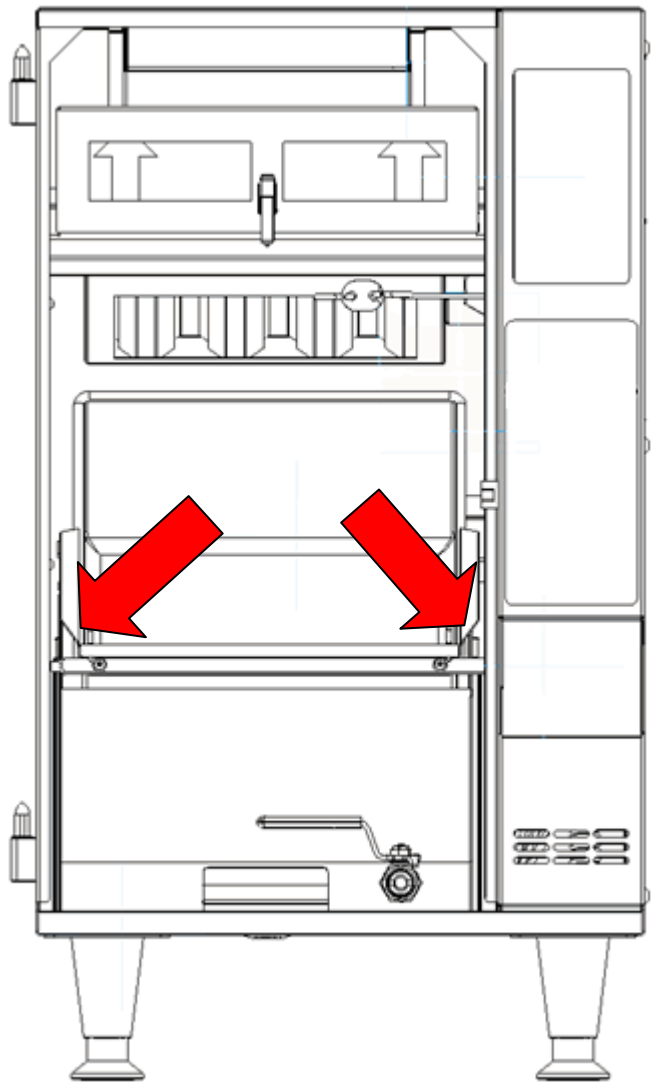

- b) Install rod into pivot slot – left side

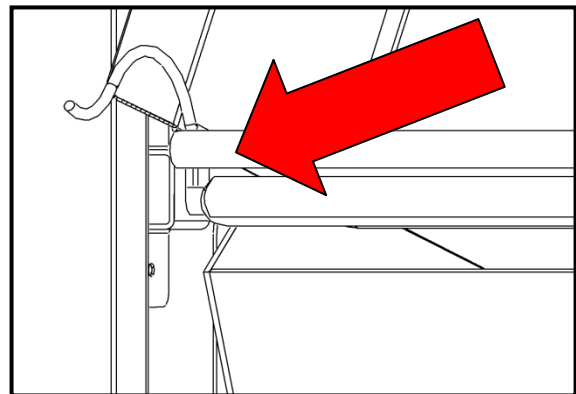

- c) Install rod into motor coupler – right side

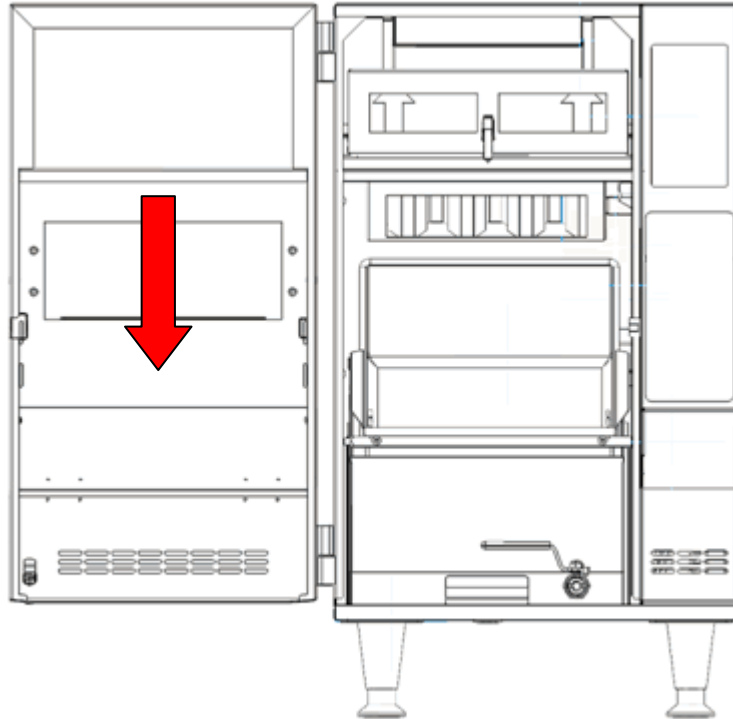
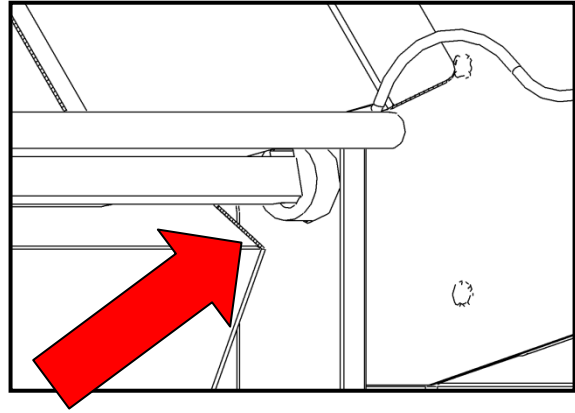

- 9) Install front panel using lift off hinges and close front panel. Turn latches $\frac{1}{4}$ turn clockwise and press down.

ASSEMBLY (Continued)

- 12) Install drawer sleeve using 4 captive screws. Tighten securely.

Note: Bottom of drawer sleeve should sit tight on front panel.

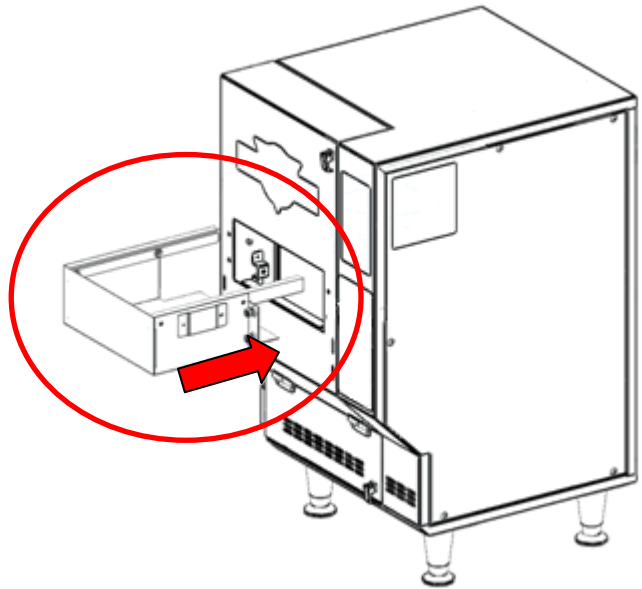

- 13) Install heat lamp. Connect cord set to connector on left side of heat lamp and back electrical outlet.

Note: Tabs on back of heat lamp should fit into slots on front panel

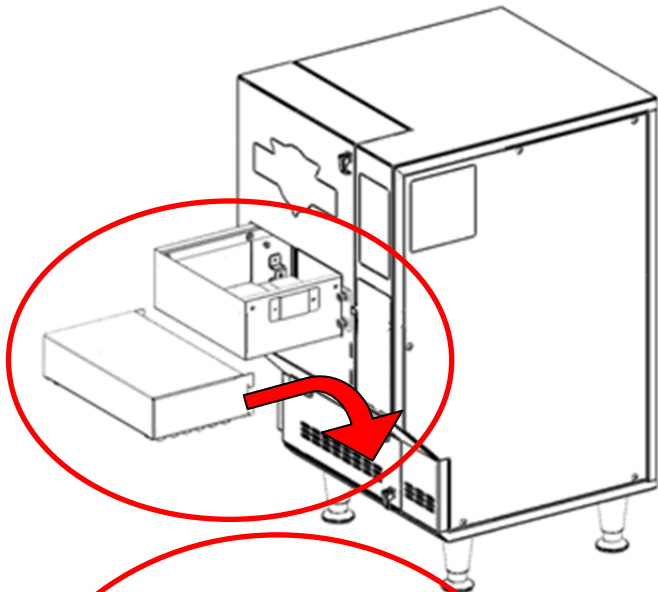

- 14) Install drawer cover

Note: Tabs on inside of cover should fit into slots on sides of drawer sleeve

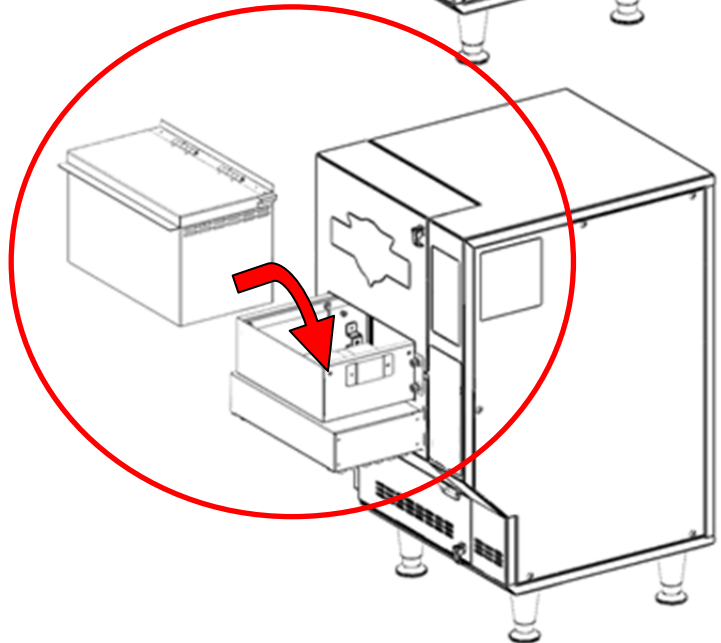

ASSEMBLY (Continued)

- 15) Install basket ramp using hinges. Install basket ramp springs onto mounts provided. For proper airflow and sanitation, basket ramp must always be installed.

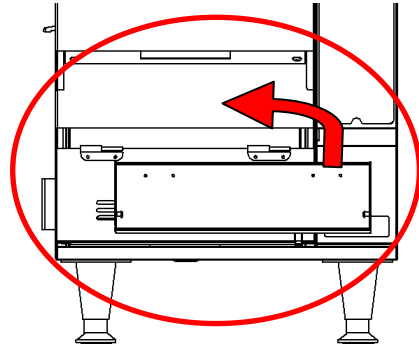

- 16) Install drawer ramp into hole on right side and slots on left side of inside of front panel.

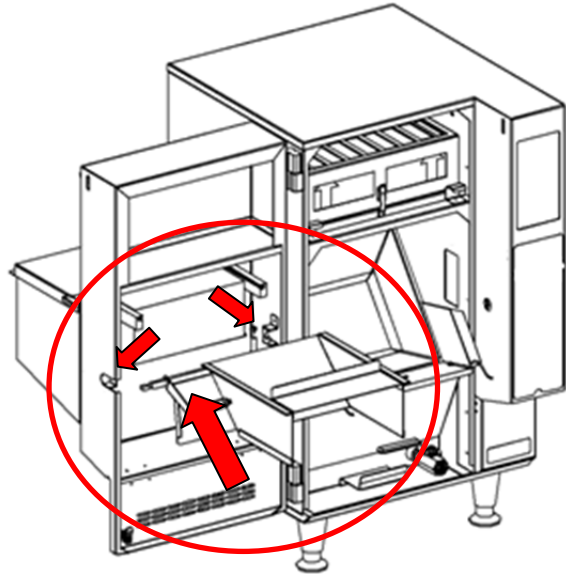

- 17) Install drawer shovel into guides and push shovel in completely.

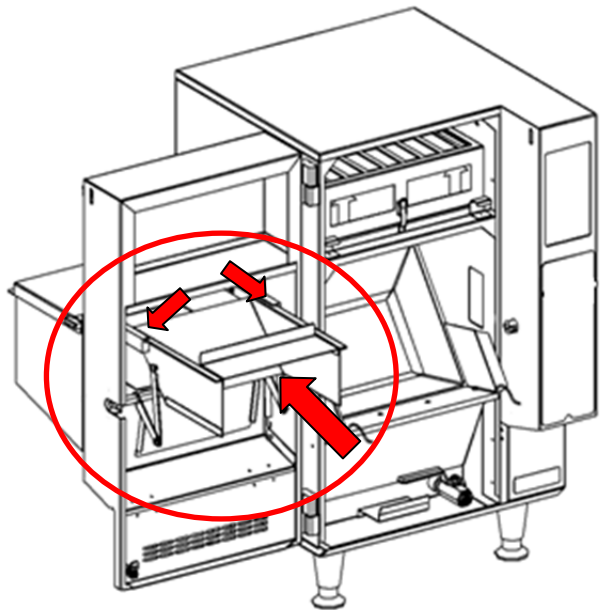

- 18) Close and lock the front panel by turning latches $\frac{1}{4}$ turn clockwise and pressing down.

Plug in fryer and press . The fryer will now begin heating. In a few minutes, you will be ready to start cooking!

COOKING

Press **Preset** to toggle between modes

Manual Mode	Preset Mode	Preset Locked Mode	RapidFry™ Mode
Load Food	Load Food	Load Food	Load Food
Select Time	Press Preset	Select Preset #	
Press Start	Select Preset #	<i>Manual Mode shown below</i>	

1. Open Drawer Lid

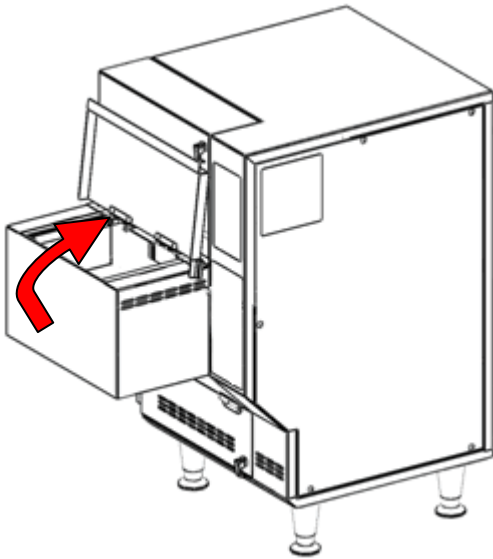

2. Fill Drawer

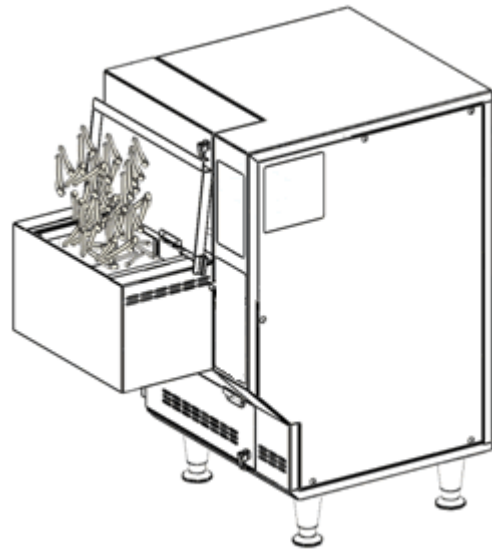

3. Close Drawer Lid

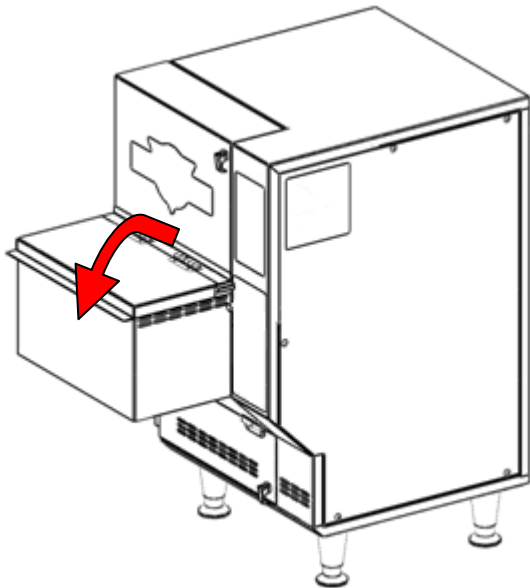

4. Enter Time/Press Start

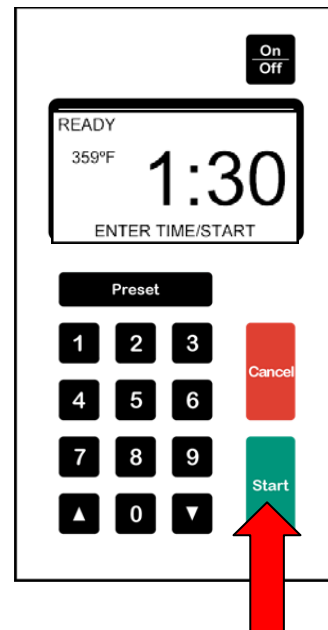

CLEANING

Daily Maintenance

⚠ CAUTION Do not unplug the fryer and always make sure the fryer is turned off

⚠ CAUTION Do not touch heater module, oil vat or oil unless you are sure it has cooled

- 1) Wipe basket with paper towel to remove crumbs and food particles
- 2) Wipe crumbs, oil and any other food matter from inside of drawer using a paper towel
- 3) Clean outside of fryer with a good stainless steel cleaner and wipe dry
- 4) Lubricate rails of shovel and bottom of drawer using an approved food grade grease or silicone lubricant

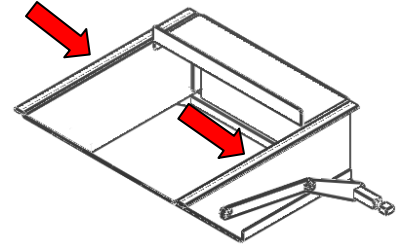

⚠ CAUTION Do not clean the outside or any other stainless steel part using abrasive cleaners

- 5) Check oil level on the back of vat to make sure it is up to cold line (at room temperature). If not, add oil as necessary. Replace the cooking oil once a week or more often if necessary. Use a **COMMERCIAL GRADE DEEP FRY COOKING OIL**.

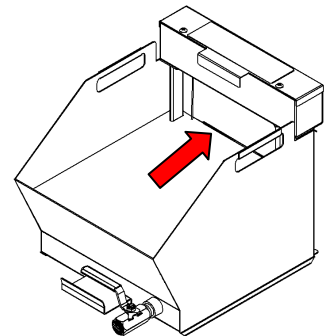

Weekly Maintenance

⚠ CAUTION Do not unplug the fryer and always make sure the fryer is turned off

⚠ CAUTION Do not touch heater module, oil vat or oil unless you are sure it has cooled

- 1) Open front panel by lifting and turning latches. Remove drawer parts and wash in soap and hot water. Rinse well in hot water and dry.
- 2) Remove air filter cartridge and set aside (for replacement, see page 17).

⚠ CAUTION Do not wash air filter cartridge

CLEANING (Continued)

3) Attach oil hose and drain cooking oil from vat into containers for disposal. Have empty containers handy for proper disposal of used cooking oil. A rendering company can help with proper disposal.

4) Remove basket lift, oil vat and heater module (picture right). Spray parts with oven cleaner, enclose with plastic bag for at least one hour or leave overnight if possible. Wash in soap and hot water and rinse well in hot water. Rinse parts in a solution of: 1 part white vinegar [5% acetic acid] and 2 parts water. **The vinegar rinse is very important.** It neutralizes soap residue that causes oil breakdown foaming. Soap residue turns oil dark and reduces its performance significantly. Clear water rinse parts. **Clean the male and female terminals on connectors with rubbing alcohol and cotton swab.**

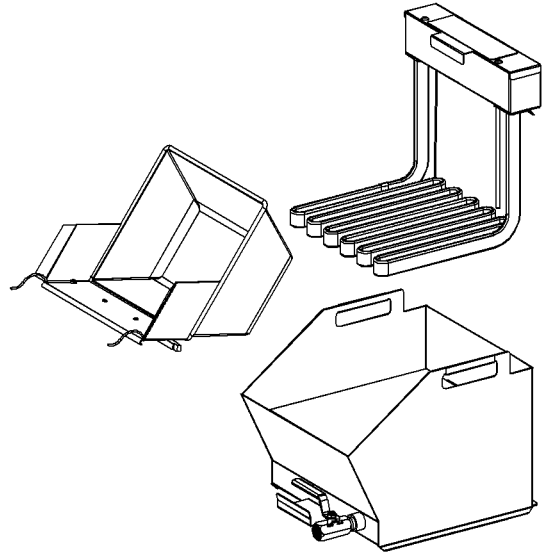

⚠ CAUTION **The heater box must NOT be immersed in water or other liquid.**

⚠ CAUTION **Do not spray male connector**

5) Remove spill tray and drain any oil that has accumulated. Wash in soap and hot water. Rinse well in hot water and dry.

6) With internal components removed, clean cooking and filter compartments with grease cutting soap or oven cleaner if necessary. Rinse with damp cloth and dry.

⚠ CAUTION **Do not spray female connector**

7) Clean countertop and external surfaces.

8) Re-install all parts (see ASSEMBLY page 8)

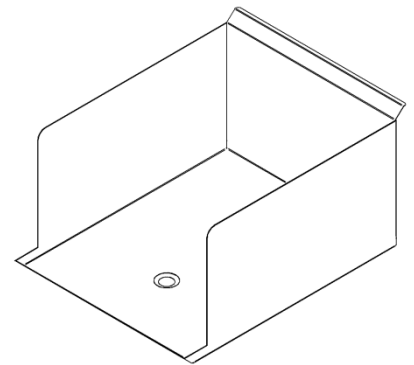

CLEANING (Continued)

Periodic Maintenance

Air Filter Cartridge Replacement

- Replace the air filter cartridge at least once every 2 months, more often for higher volume usage. Replacement is safer and easier when the fryer is cool rather than hot.
- Only PERFECT FRY filters may be used in your PERFECT FRYER.

Steps to replace air filter cartridge:

- 1) Open front panel by lifting and turning latches
- 2) Release latch on air filter cage, and remove air filter cage and air filter cartridge from filter compartment
- 3) Remove old used air filter cartridge from air filter cage
- 4) Wipe air filter cage clean
- 5) Fit air filter cage over new air filter cartridge and write date on cartridge
(↑↑ Arrows up)
- 6) Install air filter cage and new air filter cartridge firmly back into filter compartment and latch in place
- 7) Close front panel and latch shut

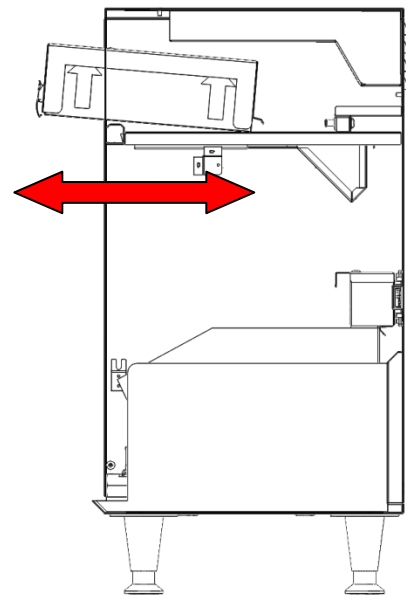
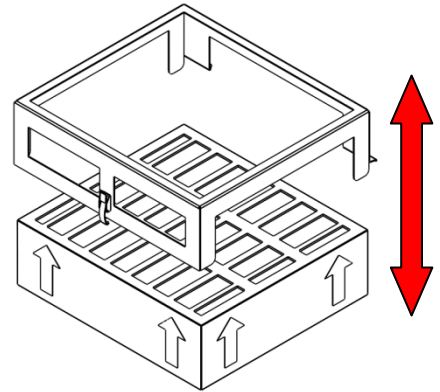

TIPS ON DEEP FRYING

Great Food in Less Time

- **Use premium quality commercial deep frying oil.** Canola and Soybean oils are recommended. Do not use household cooking oils from your local supermarket. Poor quality oils may shorten the life of the air filter cartridge.
- **Keep food frozen until ready to fry.** Frozen product will absorb less oil during the cooking process.
- **Remove ice from food.** Ice results in excess bubbling and spillage of oil out of the vat.
- **Minimize the moisture.** Excess moisture extends the cooking time. Water, ice, sugar and breading all contribute to shortening the life of the oil.
- **Try to reduce the amount of breading that falls off of the food.** Breading often has sugar and other ingredients that will reduce the oil's life and darken the appearance of food. Consider filtering the oil to remove the breading particles.
- **Do not overfill the drawer.** Excess food may not be cooked properly.

**MINIMIZE THE MOISTURE
REDUCE THE COOKING TIME
MAXIMIZE THE PROFIT**

Common Questions

- **How Much Oil to Use?**
The PERFECT FRY has a capacity of 2.75 gallons of oil (11L). Fill the oil vat to the cold line only.
- **How Much to Fry?**
Fill the drawer to the top only. The drawer has an approximate capacity of 3 lbs (1.5 kg) of product per cycle. Whatever you can fit in the drawer is what you can fry.
- **What is the Ideal Temperature Range for Cooking?**
The ideal temperature range for cooking product is between 350°F and 360°F (177°C and 182°C). The factory default setting for cooking temperature is 350°F (177°C).
- **Should Frozen Food Be Defrosted?**
DO NOT THAW FROZEN FOOD! Frozen foods only should be put directly into the fryer in order to minimize moisture.
- **Can I Refreeze Frozen Foods?**
NO, do not refreeze frozen foods. Foods that are refrozen can absorb more oil, which will result in a dry, brittle and tasteless product.

OIL FACTS

Frying oil is especially formulated to withstand high temperatures. For this reason, you must ensure you are using the right product. Liquid vegetable shortening is produced by several companies; the oil has an additive and/or has been formulated to increase the performance during high temperature usage.

DO NOT USE OIL THAT IS RECOMMENDED BOTH FOR SALAD AND FRYING!

Fill the oil vat to the cold line only. The oil expands as it heats and if overfilled, the bottom of the basket will remain in the oil when in the up/serve position.

How Much to Fry?

- Fill the drawer no higher than the top. Do not overfill the drawer.
- Keep drawer and basket clean and free of breading/batter build up.
- Remove ice crystals or excess water before frying.
- Do not salt or season before frying.
- Remove surplus and/or batter before frying.
- Do not allow frozen food to thaw before frying.
- Drain fried foods before serving.

How Hot is TOO Hot?

Ideal frying temperature range is between 350°F and 360°F (177°C and 182°C). Factory default setting is 350°F (177°C). When frying at too low a temperature, food absorbs more oil which increases oil consumption.

Excessive Oil Usage?

The fried product is absorbing oil. Possible reasons for this include:

- Excess breading or batter, shake off excess before frying.
- Allow basket to drain longer, adjust the drain time.
- Food is being allowed to thaw before frying.

Cleaning Your Fryer?

- Refer to the Cleaning section of this owner's manual. Remember to clean the basket and drawer daily.

Filtering Your Oil?

The most important procedure you can do is to maintain the oil, extending its life:

- Filter at least once a day, preferably first thing in the morning when the oil is at room temperature.
- Filtering removes all the contaminants from the previous days cooking.
- Clean the oil vat.

Points to Remember:

- Clean the cooking chamber at least once a week and rinse thoroughly.
- Filter oil daily.
- Do not overheat oil.
- Use the standby mode when possible.
- Do not salt product prior to frying.
- Remove ice crystals and moisture before frying.
- Maintain oil level in vat, check to ensure it is at the hot line often.
- The oil is dead when foaming appears continuously on the oil surface

Your oil, product taste, and customers depend on you.

OIL FACTS (Continued)

If the oil temperature is set too high, the food will cook on the exterior and the interior will be undercooked. When the interior is cooked completely, the exterior will be overdone or burnt. The higher temperature will also cause the oil to break down faster and smoke.

During slow periods, take advantage of the standby mode which allows the oil to cool down to 275°F (135°C), prolonging the oil life and reducing energy costs while allowing quick recovery time when required.

The oil temperature should not be adjusted when cooking different products. Adjust the cooking time instead.

Frozen Foods

Put frozen foods directly into the fryer. **DO NOT THAW FROZEN FOODS!** Blot excess water from food before frying. Remove ice crystals that may be at the bottom of the product bag.

OIL AND WATER DO NOT MIX! Water reacts with oil and makes it break down rapidly resulting in darkening, smoking and foaming (a process called hydrolysis). Excess water in the oil can cause the following problems:

- Unnecessary temperature drop meaning longer cooking times.
- More energy usage to maintain cooking temperature.
- Excessive splattering inside the fryer resulting in a mess to clean up.
- Decreased life of the air filter and the oil.

Refreezing Frozen Foods?

Frozen foods should be fried frozen. Foods that are refrozen can absorb more oil and make your fried foods taste greasy. Refrozen food forms excessive ice and these ice crystals can bond food pieces together causing clumping. Remember:

- Always FRY FOOD FROZEN.
- NEVER REFREEZE thawed food.
- REMOVE ice crystals from product before frying.
- DO NOT accept thawed or refrozen product from supplier.

Excessive Foaming?

The main reason for foaming is improper rinsing of oil vat after cleaning:

- To remove soap residue, rinse 3 times with water after cleaning or neutralize with a water and vinegar solution (1 part white vinegar to 2 parts water).
- Take care of your oil; use standby mode during slow periods. High temperature and oxygen contribute to oil breakdown. Filter oil and clean vat at least once a day when using heavily breaded products.

Excessive Smoking/Oil Darkening?

- Oil is too hot, check temperature.
- Inadequate filtering, breading or batter build-up in vat causes oil breakdown, giving food a bitter taste.
- Moisture content is too high. Use precooked frozen products only. Remember to remove ice crystals.

Grease Soaked Food?

- Frozen food is being allowed to thaw before frying.
- Oil is in the advanced stages of breakdown, replace immediately.
- Oil temperature is too low, check temperature.
- Product has too much breading or batter, remove excess.

OIL FACTS (Continued)

Food Not Browning Properly?

- New oil may not brown the product; check color again after a few basket loads.
- Too much product is in the basket; fill no higher than the fill line.
- Product is not frying long enough, follow manufacturers suggested cooking times.
- Oil temperature is too low, check oil temperature.
- Product is frying in excess foam.
- Oil level is too low, check the oil level.

Premature Oil Breakdown?

- Oil is at full temperature during slow periods, use standby mode.
- Oil is contaminated. Never use wire brushes, copper pads or steel wool for cleaning. Use a hard bristle brush and filter oil regularly. Rinse with water vinegar solution.
- Also, see section; **HOW HOT IS TOO HOT?**

Statements used in OIL FACTS section are taken from:

- NAFEM Food Service Industry
- Canola Research Foundation
- Sysco Oil Publication

OPERATING INSTRUCTIONS

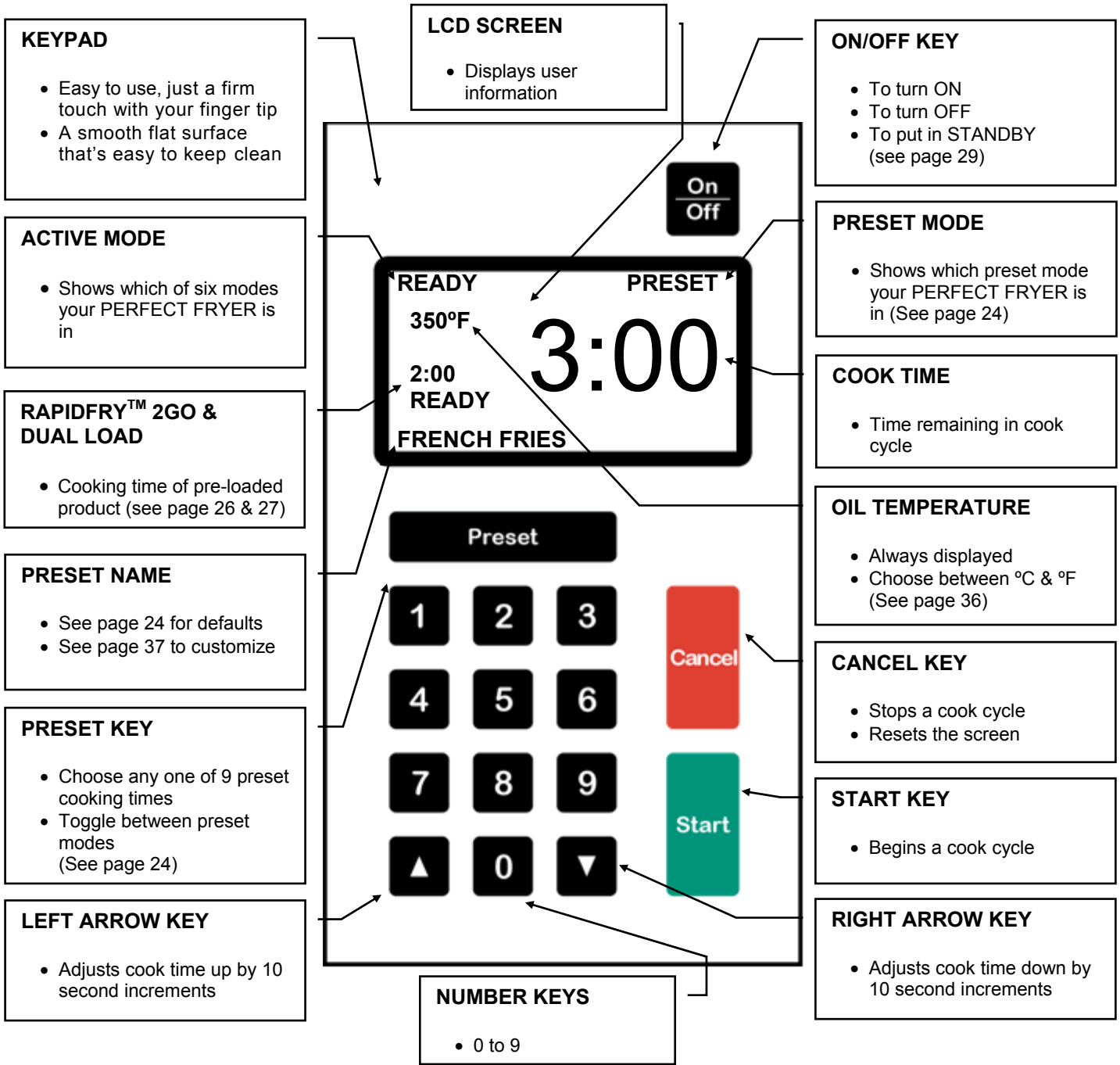



Table 1 Preset Mode Functionality

Feature	Manual Mode	Preset Mode	Preset Locked Mode	RapidFry™ Mode
<i>Manually enter cook time</i>	<input checked="" type="checkbox"/>	<input type="checkbox"/>	<input type="checkbox"/>	<input type="checkbox"/>
<i>Automatically enters preset time</i>	<input type="checkbox"/>	<input checked="" type="checkbox"/>	<input checked="" type="checkbox"/>	<input checked="" type="checkbox"/>
<i>Remains in same mode after cook cycle</i>	<input type="checkbox"/>	<input type="checkbox"/>	<input checked="" type="checkbox"/>	<input checked="" type="checkbox"/>
<i>Eliminates need to use keypad</i>	<input type="checkbox"/>	<input type="checkbox"/>	<input type="checkbox"/>	<input checked="" type="checkbox"/>

OPERATING INSTRUCTIONS (Continued)

Starting Up

YOU DO THIS

1) Press  for ½ second.

2) Allow 10 to 15 minutes for oil to reach operating temperature (350°F or 177°C).

LCD

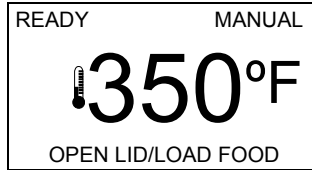
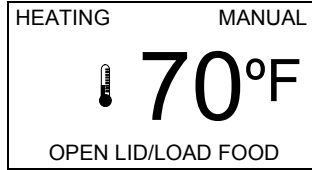

PERFECT FRYER DOES THIS

- 1) Now in **HEATING** mode
- 2) Oil temperature rising to operating temperature
- 3) Once operating temperature is reached, now **READY** to start cooking.

Manual Mode

- 1) Open drawer lid
- 2) Fill drawer with food product

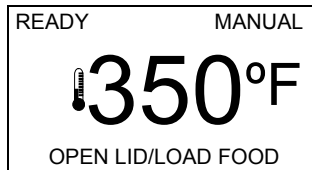

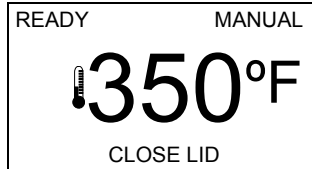

- 1) LCD displays **OPEN LID/LOAD FOOD**

3) Close drawer lid



- 2) Basket lowers into oil
- 3) LCD displays **CLOSE LID**

4) Enter cook time and press 
ex: **1 3 0** 

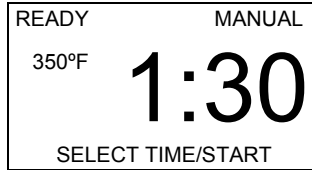

- 4) LCD displays **SELECT TIME/START**
- 5) Drawer loads food into oil
- 6) **COOKING** cycle begins
- 7) Fryer counts down time remaining
- 8) Basket raises out of oil
- 9) Food drains (time adjustable)
- 10) Fryer "beeps" to let you know that food is cooked
- 11) Fryer dumps food into warming tray

Note: DO NOT OPEN DRAWER LID OR FRONT PANEL WHEN PRODUCT IS LOADING

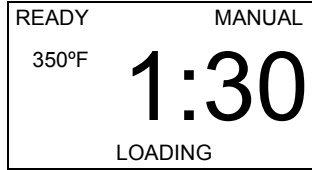

5) Serve food from warming tray

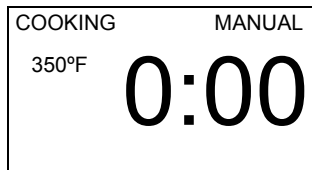

- 12) **COOKING** cycle is complete

OPERATING INSTRUCTIONS (Continued)

Preset Times

Cooking Times & Names (factory defaults)								
Preset	Name	Time	Preset	Name	Time	Preset	Name	Time
1	FRENCH FRIES	3:00	4	POPPERS	3:00	7	FISH FILLETS	4:00
2	CHICKEN TENDERS	4:00	5	CHEESE BITES	2:00	8	CHICKEN WINGS	4:00
3	ONION RINGS	2:30	6	CORN DOGS	3:00	9	CHICKEN & FRIES	4:00

NOTE: Pressing **Preset** repetitively will toggle between **MANUAL** mode, **PRESET** mode, **PRESET LOCKED** mode and **RAPIDFRY™** mode.

NOTE: The default presets are programmed and displayed to show you the **PERFECT FRYER's** capabilities. We recommend that you change the presets to match your own requirements. Please refer to page 37.

Preset Mode

YOU DO THIS

- 1) Open drawer lid
- 2) Fill drawer with food product
- 3) Close drawer lid
- 4) Press **Preset**

- 5) Press **1** (for example)
Cook cycle starts automatically

Note: You can choose between 9 different presets

Note: DO NOT OPEN DRAWER LID OR FRONT PANEL WHEN PRODUCT IS LOADING

- 6) Serve food from warming tray

LCD

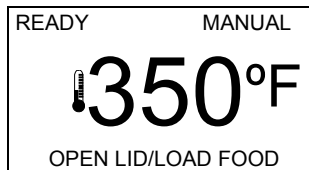
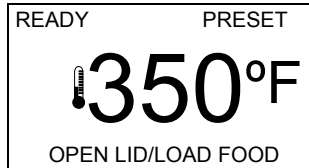

PERFECT FRYER DOES THIS

- 1) Now in **PRESET** mode
- 2) LCD displays **PRESET**
- 3) Basket lowers into oil
- 4) LCD displays **FRENCH FRIES** (default is 3:00)
- 5) Drawer loads food into oil
- 6) **COOKING** cycle begins
- 7) Fryer counts down time remaining
- 8) Basket raises out of oil
- 9) Food drains (time adjustable)
- 10) Fryer "beeps" to let you know that food is cooked
- 11) Fryer dumps food into warming tray
- 12) **COOKING** cycle is complete
- 13) Fryer returns to **READY** mode
- 14) Fryer returns to **MANUAL** mode

OPERATING INSTRUCTIONS (Continued)

Preset Locked Mode

YOU DO THIS

- 1) Open drawer lid
- 2) Fill drawer with food product
- 3) Close drawer lid
- 4) Press **Preset** + **Preset**
- 5) Press **2** (for example)
Cook cycle starts automatically

Note: You can choose between 9 different presets

Note: DO NOT OPEN DRAWER LID OR FRONT PANEL WHEN PRODUCT IS LOADING

- 6) Serve food from warming tray
- 7) Follow steps 1 through 3 and press desired preset number to cook another order this way

LCD

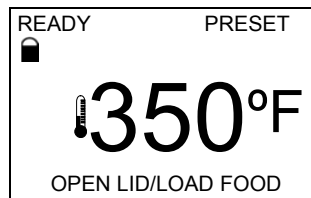
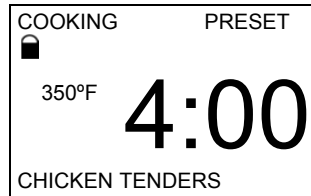
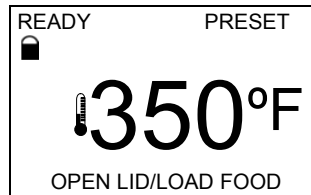

PERFECT FRYER DOES THIS

- 1) Now in **PRESET LOCK** mode
- 2) **PRESET** is displayed on LCD
- 3) LCD displays **CHICKEN TENDERS** (default is 4:00)
- 4) Drawer loads food into oil
- 5) **COOKING** cycle begins.
- 6) Fryer counts down time remaining
- 7) **COOKING** cycle is complete
- 8) Basket raises out of oil
- 9) Food drains (time adjustable)
- 10) Fryer "beeps" to let you know that food is cooked
- 11) Fryer dumps food into warming tray
- 12) **COOKING** cycle is complete
Note: Still in **PRESET** mode

RapidFry™ Mode

- 1) Open drawer lid
- 2) Fill drawer with food product
- 3) Close drawer lid
- 4) Press **Preset** 3 times
- 5) Press **2** (for example)
Cook cycle starts automatically

Note: You can choose between 9 different presets

Note: DO NOT OPEN DRAWER LID WHEN PRODUCT IS LOADING

- 6) Serve food from warming tray
 - 7) Follow steps 1 through 3
- Note: If you are using the same preset repetitively, there is no need to use the keypad. The movement of the drawer lid controls the cook cycle.

- 8) Press **Cancel** to change the preset used for **RAPIDFRY**
- 9) Press **1** (for example)

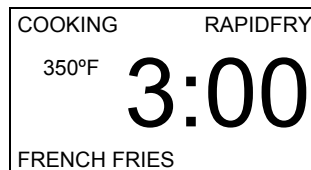
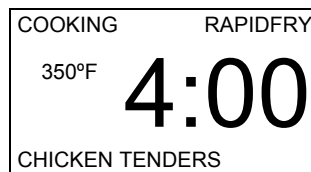
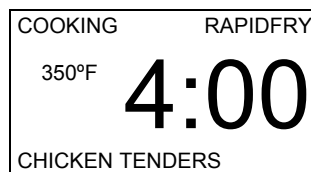
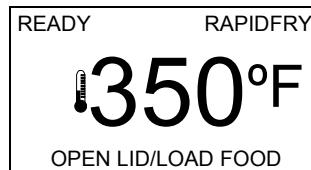

- 1) Now in **RAPIDFRY** mode
 - 2) **RAPIDFRY** is displayed on LCD
 - 3) LCD displays **CHICKEN TENDERS** (default is 4:00)
 - 4) Drawer loads food into oil
 - 5) **COOKING** cycle begins.
 - 6) Fryer counts down time remaining
 - 7) Basket raises out of oil
 - 8) Food drains (time adjustable)
 - 9) Fryer "beeps" to let you know that food is cooked
 - 10) Fryer dumps food into warming tray
 - 11) **COOKING** cycle is complete
- Note: Still in **RAPIDFRY** mode and a new cook cycle time for existing preset. The existing preset remains until it is cancelled and changed.

OPERATING INSTRUCTIONS (Continued)

RapidFry™ 2GO

YOU DO THIS

LCD

PERFECT FRYER DOES THIS

- 1) Open drawer lid
- 2) Fill drawer with food product
- 3) Close drawer lid

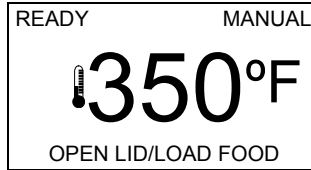

- 1) Basket lowers into oil

- 4) Enter cook time and press **Start**
ex: **1 3 0** **Start**

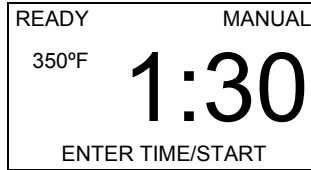

- 2) Drawer loads food into oil
- 3) **COOKING** cycle begins
- 4) Fryer counts down time remaining

Note: DO NOT OPEN DRAWER LID OR FRONT PANEL WHEN PRODUCT IS LOADING

- 5) Open drawer lid after product is finished loading
- 6) Fill drawer with food product
- 7) Close drawer lid



- 8) Enter cook time and press **Start**
ex: **2 0 0** **Start**



- 5) LCD displays time and status of preloaded **COOKING** cycle

- 9) Serve food from warming tray

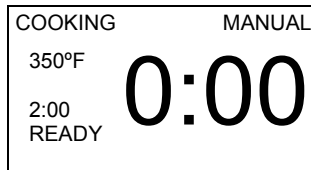

- 6) Basket raises out of oil
- 7) Food drains (time adjustable)
- 8) Fryer “beeps” to let you know that food is cooked
- 9) Fryer dumps food into warming tray

- 10) Follow steps 5 through 8 to preload another **COOKING** cycle



- 10) Preloaded **COOKING** cycle begins automatically after original **COOKING** cycle is finished

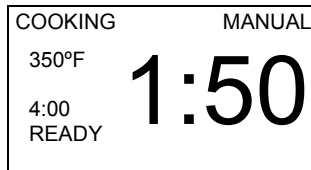

RAPIDFRY™ 2GO works with all the different preset modes and behaves according to the mode. Example: for RAPIDFRY™ mode, simply opening and closing the drawer lid will display the time and status for a preloaded cooking cycle.

OPERATING INSTRUCTIONS (Continued)

Dual Load

YOU DO THIS

- 1) Open drawer lid
- 2) Fill drawer with first food product (ex: chicken)
- 3) Close drawer lid
- 4) Press **Preset**
- 5) Press **9** (for example)
Cook cycle starts automatically

Note: Preset 9 has been programmed for dual load time (refer to page 37)

Note: DO NOT OPEN DRAWER LID OR FRONT PANEL WHEN PRODUCT IS LOADING

- 6) Open drawer lid
- 7) Fill drawer with second food product (ex: fries)
- 8) Close drawer lid

- 9) Serve food from warming tray

LCD

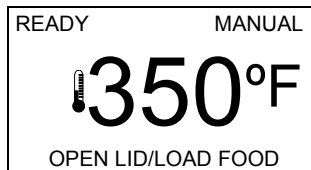
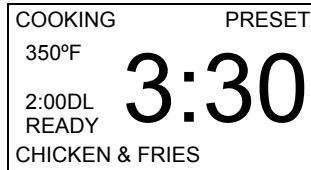
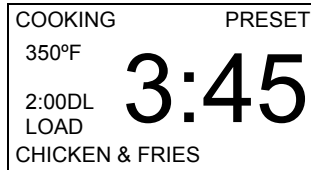
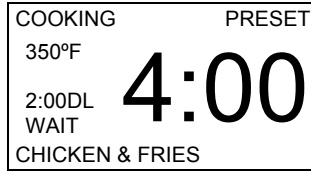
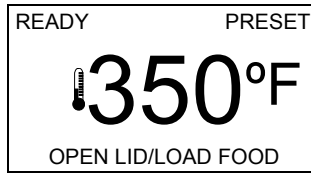

PERFECT FRYER DOES THIS

- 1) Basket lowers into oil
- 2) LCD displays **CHICKEN & FRIES** (default is 4:00 for chicken)
- 3) LCD displays 2:00DL and **WAIT** (default is 2:00 for fries)
- 4) Drawer loads chicken into oil
- 5) **COOKING** cycle begins.
- 6) Fryer counts down time remaining
- 7) LCD displays 2:00DL and **LOAD**
- 8) Fryer “beeps” every 10 seconds to remind you to load second product (ex: fries).
- 9) LCD displays 2:00DL and **READY**
- 10) At 2:00 drawer loads fries into oil
- 11) Time and status of dual load disappears
- 12) Basket raises out of oil
- 13) Food drains (time adjustable)
- 14) Fryer “beeps” to let you know that food is cooked
- 15) Fryer dumps both food products into warming tray
- 16) **COOKING** cycle is complete

DUAL LOAD TIME works with all the preset modes (regular preset mode, preset locked mode and RAPIDFRY™ mode) and behaves according to the mode. To program a preset DUAL LOAD TIME, please refer to page 37. Example: for RAPIDFRY™ mode, simply opening and closing the drawer lid will display the time and status for a preloaded cooking cycle.

THE COMBINATION OF BOTH LOADS SHOULD NOT BE GREATER THAN A DRAWER FULL. ONE DRAWER FULL IS EXACTLY HOW MUCH THE BASKET CAN ACCEPT.

OPERATING INSTRUCTIONS (Continued)

Cooking Time Correction

<u>YOU DO THIS</u>	<u>LCD</u>	<u>PERFECT FRYER DOES THIS</u>
1) Enter incorrect cooking time (4:30 instead of 3:30 for example)	<div style="border: 1px solid black; padding: 5px; text-align: center;"> COOKING MANUAL 4:30 </div>	7) Drawer loads food into oil
2) Press 4 3 0 Start		8) COOKING cycle begins
3) Press Cancel	<div style="border: 1px solid black; padding: 5px; text-align: center;"> PAUSE MANUAL 350°F 4:29 PRESS START/CANCEL </div>	9) Fryer counts down time remaining
4) Press 3 3 0 Start		4) COOKING cycle PAUSE
Note: Pressing Cancel instead of entering a new time will complete the cook cycle and dump the food product into the warming tray	<div style="border: 1px solid black; padding: 5px; text-align: center;"> PAUSE MANUAL 350°F 3:30 PRESS START/CANCEL </div>	5) Basket raises out of oil
		6) LCD displays PRESS START/CANCEL
	<div style="border: 1px solid black; padding: 5px; text-align: center;"> READY MANUAL 350°F OPEN LID/LOAD FOOD </div>	6) LCD displays new time
		7) Basket lowers into oil
		8) Fryer counts down new time remaining

Open Drawer Lid – Paused Cook Cycle

1) Open drawer lid during product loading	<div style="border: 1px solid black; padding: 5px; text-align: center;"> READY MANUAL 350°F 1:24 CLOSE LID </div>	1) COOKING cycle PAUSE
2) Close drawer lid to continue cooking cycle		2) Basket raises out of oil
	<div style="border: 1px solid black; padding: 5px; text-align: center;"> COOKING MANUAL 350°F 1:24 </div>	3) Brief pause, basket lowers into oil
		4) Drawer completes loading product
		5) COOKING cycle begins
		6) Fryer counts down time remaining

DO NOT OPEN DRAWER LID OR FRONT PANEL WHEN PRODUCT IS LOADING

OPERATING INSTRUCTIONS (Continued)

Standby Mode

SEE THIS LCD

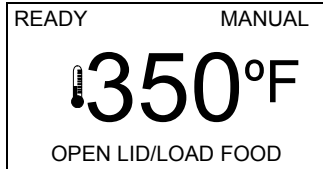

DO THIS

- 1) Press  and  together
- 2) Release both

Note: Temperature will decrease to 275°F (135°C) to set default standby temperature, see page 31 for more information

GET THIS LCD

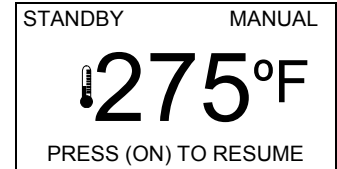

Note: During slow periods, using standby mode reduces energy costs, allows a quick recovery and minimizes oil breakdown.

Shutting Down

YOU DO THIS

TURN YOUR PERFECT FRY OFF:

- At end of day
- To replace deep fry oil
- To clean
- For other service or maintenance

- 1) Press 

**DO NOT UNPLUG FRYER
Fans must remain ON
during COOLDOWN mode**

LCD

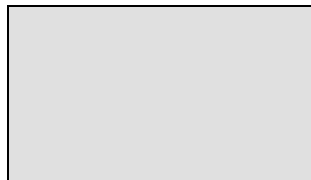
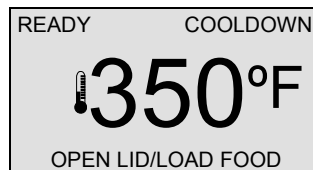
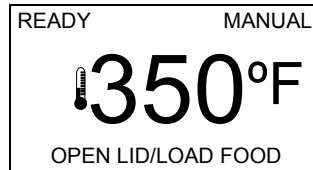

PERFECT FRYER DOES THIS

- 1) Now in **READY** mode
- 2) Now in **COOLDOWN** mode
- 3) No power to heater element
- 4) Fans continue to cool fryer
- 5) Fryer counts down temperature
- 6) LCD backlighting goes off
- 7) Temperature decreases to 122 °F (50°C)
- 8) Fans stop
- 9) LCD goes blank
- 10) Your PERFECT FRYER is off

USER DEFINED OPTIONS

CUSTOMIZE YOUR PERFECT FRYER WITH YOUR OWN SETTINGS

- CTS™ Cook Time Sensitivity
- Temperature read-out: °C or °F
- Preset Cooking Times
- Cooking Oil Standby Temperature
- Count of Cook Cycles
- Cooking Oil Temperature
- Basket Drain Time
- Sound Volume
- And Much More

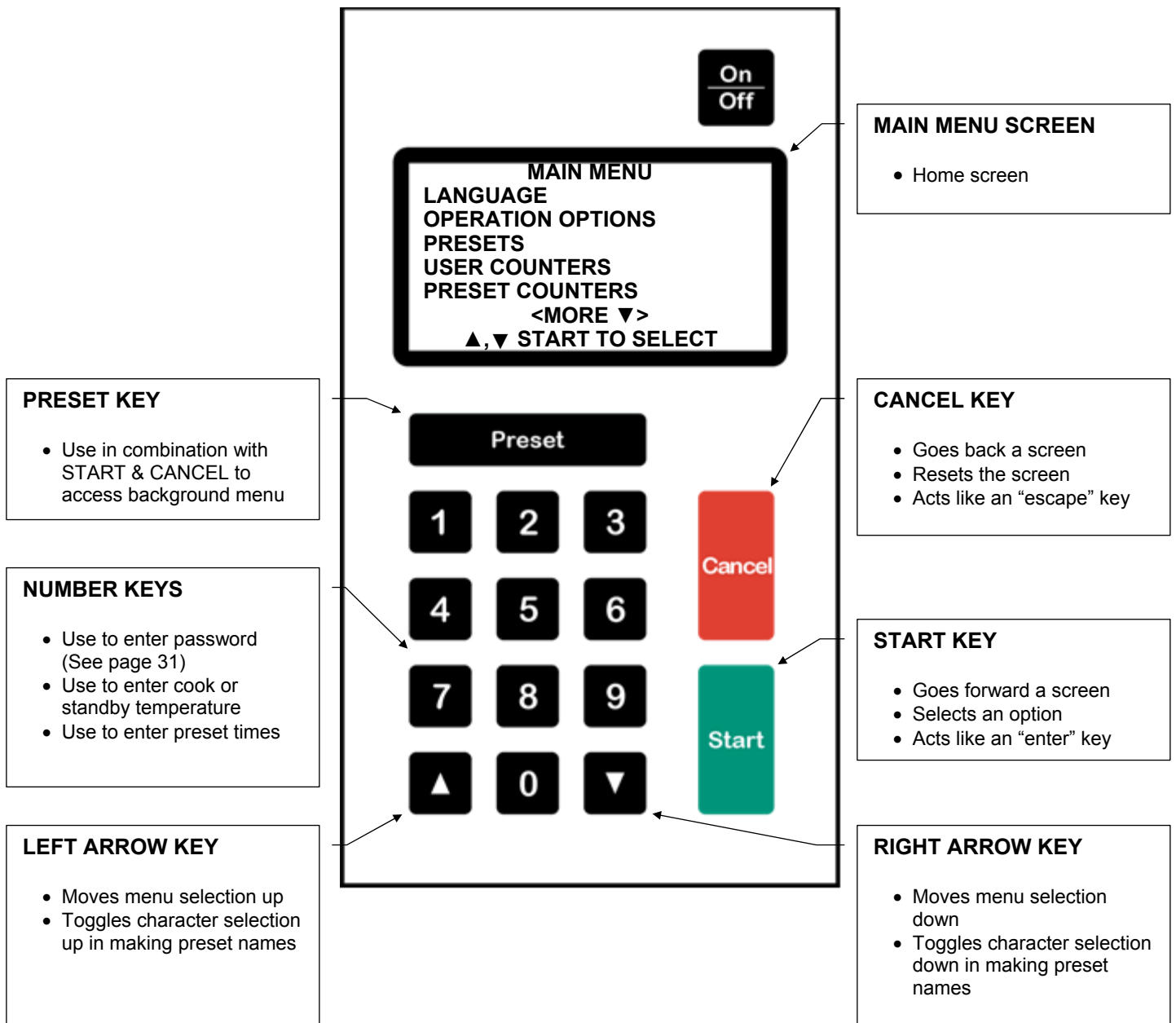

USER DEFINED OPTIONS (Continued)

Background Menu - Accessing

<u>SEE THIS LCD</u>	<u>DO THIS</u>	<u>GET THIS LCD</u>										
<p>READY MANUAL</p> <p style="font-size: 2em; text-align: center;">350°F</p> <p>OPEN LID/LOAD FOOD</p>	<p>1) Press Cancel Start Preset together</p> <p>2) Release together</p>	<p>PFC VER.: 6.X.X FRYER SN# XXXXX</p> <p>ENTER PASSWORD:</p> <p>▶</p>										
<p>PFC VER.: 6.X.X FRYER SN# XXXXX</p> <p>ENTER PASSWORD:</p> <p>▶****</p>	<p>3) Press 4 7 5 0 Start</p>	<p style="text-align: center;">MAIN MENU</p> <p>LANGUAGE OPERATION OPTIONS PRESETS USER COUNTERS PRESET COUNTERS <MORE ▼> ▲, ▼ START TO SELECT</p>										
<p style="text-align: center;">MAIN MENU</p> <p>LANGUAGE OPERATION OPTIONS PRESETS USER COUNTERS PRESET COUNTERS <MORE ▼> ▲, ▼ START TO SELECT</p>	<p>4) Scroll down to the desired menu selection and press Start</p>	<p style="text-align: center;">OPERATION OPTIONS</p> <table border="0"> <tr><td>WAIT MODE</td><td><input type="checkbox"/></td></tr> <tr><td>STANDBY MODE</td><td><input checked="" type="checkbox"/></td></tr> <tr><td>PRESET MODE</td><td><input type="checkbox"/></td></tr> <tr><td>BUZZER VOLUME</td><td>9</td></tr> <tr><td>KEY VOLUME</td><td>4</td></tr> </table> <p><MORE ▼> ▲, ▼ START TO SELECT</p>	WAIT MODE	<input type="checkbox"/>	STANDBY MODE	<input checked="" type="checkbox"/>	PRESET MODE	<input type="checkbox"/>	BUZZER VOLUME	9	KEY VOLUME	4
WAIT MODE	<input type="checkbox"/>											
STANDBY MODE	<input checked="" type="checkbox"/>											
PRESET MODE	<input type="checkbox"/>											
BUZZER VOLUME	9											
KEY VOLUME	4											

CTS™ (Cook Time Sensitivity)

- CTS™ adjusts cooking time to compensate for the drop in cooking oil temperature when a basket of product is placed into the fryer. CTS™ increases cooking time to accommodate for differences in product moisture content, basket-load size, and initial temperature.
- A proper CTS™ setting will ensure a high quality product. For example; 2 lbs of French fries will cook to the same quality as only 6 ounces of French Fries.
- In addition to having a “global” CTS™ setting under the Operation Options menu for manually entered cook cycles, each preset can be programmed with its own individual setting. This provides for a lot of flexibility among different food products.
- Some experimenting with the range of 1 to 9 may be required to achieve optimum quality. A value of 5 is a good place to start and is the default.
- A setting of 0 means no CTS™ whatsoever.

OPERATION OPTIONS	
CTS	5
MELT CYCLE	<input type="checkbox"/>
HOLD TIME	0M
FTS	3
MANUAL DRAWER	<input type="checkbox"/>
<MORE ▼>	
▲, ▼ START TO SELECT	

FRENCH FRIES	
TIME:	3:00
TEMPERATURE:	350°F
CTS:	5
NAME:	FRENCH FRIES
<MORE ▲>	
▲, ▼ START TO SELECT	

Background Menu - Map

LANGUAGE

- ENGLISH (factory default)
- ESPANOL
- FRANCAIS

LANGUAGE	
ENGLISH	<input checked="" type="checkbox"/>
ESPANOL	<input type="checkbox"/>
FRANCAIS	<input type="checkbox"/>
▲, ▼ START TO SELECT	

USER DEFINED OPTIONS (Continued)

OPERATION OPTIONS

➤ WAIT MODE

- When , will not allow cooking until oil has reached operating temperature
- Default is

➤ STANDBY MODE

- When , gives user ability to put fryer into standby mode
- This is an energy saving feature which holds oil temperature at desired standby temperature
- Default is

➤ PRESET MODE

- When , only PRESET LOCKED mode and RAPIDFRY™ mode are available
- This allows the operator to better control inventories as manual cook cycles are not permitted
- Default is

➤ BUZZER VOLUME

- Intensity of “beep” for finish of cook cycle and system errors
- Choose between 0 and 9
- Default is 9

➤ KEY VOLUME

- Intensity of “beep” when a key is pressed
- Choose between 0 and 9
- Default is 4

➤ UNITS

- Temperature of oil in the vat
- Choose between °C (Celsius) and °F (Fahrenheit)

➤ DRAIN TIME

- Time a basket of cooked food sits out of the oil before finishing the cook cycle
- Choose between 0 and 30 seconds
- Default is 15 seconds

➤ COOK TEMPERATURE

- Operating temperature of the oil
- Choose between 275°F (135°C) and 375°F (190°C)
 Note: Between 350°F and 360°F (177°C and 182°C) is ideal. If the temperature is set too low, the food will absorb too much oil and taste greasy. If the temperature is set too high, the food will cook too quickly on the outside and will be too dark once the inside is cooked. It may also cause the oil to breakdown quicker and cause smoking.
- Default is 350°F (177°C)

➤ STANDBY TEMPERATURE

- Oil temperature when fryer is in standby mode
- Choose between low (ambient room temperature) and high (cook temperature)
- Default is 275°F (135°C)

➤ LCD CONTRAST

- Visibility of screen
- Choose between 0 and 9

OPERATION OPTIONS	
WAIT MODE	<input type="checkbox"/>
STANDBY MODE	<input checked="" type="checkbox"/>
PRESET MODE	<input checked="" type="checkbox"/>
BUZZER VOLUME	9
KEY VOLUME	4
<MORE>	
▲, ▼ START TO SELECT	

OPERATION OPTIONS	
UNITS	°F
DRAIN TIME	15S
COOK TEMP	350°F
STANDBY TEMP	275°F
LCD CONTRAST	5
<MORE>	
▲, ▼ START TO SELECT	

USER DEFINED OPTIONS (Continued)

➤ CTS™ COOK TIME SENSITIVITY

- Adjusts cooking time to compensate for drop in cooking oil temperature when basket of product is placed into fryer. Refer to page 31 for more information.

OPERATION OPTIONS	
CTS	5
MELT CYCLE	<input type="checkbox"/>
HOLD TIME	0M
FTS	3
MANUAL DRAWER	<input type="checkbox"/>
<MORE>	
▲, ▼ START TO SELECT	

➤ MELT CYCLE

- When , fryer will gradually melt solid blocks of shortening until temperature reaches 212°F (100°C). It is designed to prevent scorching shortening and overheating element.



- Press to cancel and heat regularly. DO NOT CANCEL IF USING SOLID SHORTENING!
- Default is

➤ HOLD TIME

- Time elapsed after cook cycle is finished
- Allows operator to monitor time since product has finished cooking
- “Beeps” and flashes hold time elapsed on LCD
- Choose between 0 and 99 minutes
- Default is 0 (disabled)

➤ FTS™ FOOD TYPE SENSITIVITY

- Adjusts cook cycle loading and unloading sequences to compensate for differences among food products being cooked.
- In addition to having a “global” FTS™ setting under the Operation Options menu for manually entered cook cycles, each preset can be programmed with its own individual setting. This provides for a lot of flexibility among different food products.
- Some experimenting with the range of 1 (normal) to 9 (very battered) may be required to achieve optimum performance. For example, chicken tenders will work well under a setting of 1 since they don't tend to stick together. However, battered french fries will need to set to 5 as they tend to stick together when they're cooked.
- 3 is the default. Please refer to chart.

FTS Value	Basket Start	# of Shakes	# of Unloads
1	In Oil	0	1
2	In Oil	0	2
3	In Oil	1 (15 seconds in)	2
4	In Oil	1 (45 seconds in)	2
5	In Oil	2 (15 & 45 in)	3
6	Drain position	0	1
7	Drain position	0	2
8	Drain position	1 (15 seconds in)	2
9	Drain position	1 (45 seconds in)	2

➤ MANUAL DRAWER

- When , will allow drawer to load during cook cycle simply by pressing
- When , will disable RAPIDFRY™ 2GO
- Default is



USER DEFINED OPTIONS (Continued)

PRESETS

- 1: FRENCH FRIES
- 2: CHICKEN TENDERS
- 3: ONION RINGS
- 4: POPPERS
- 5: CHEESE BITES
- 6: CORN DOGS
- 7: FISH FILLETS
- 8: CHICKEN WINGS
- 9: CHICKEN & FRIES

PRESETS	
1: FRENCH FRIES	3:00
2: CHICKEN TENDERS	4:00
3: ONION RINGS	2:30
4: POPPERS	3:00
5: CHEESE BITES	2:00
<MORE ▼>	
▲, ▼ START TO SELECT	

PRESETS	
6: CORN DOGS	3:00
7: FISH FILLETS	4:00
8: CHICKEN WINGS	4:00
9: CHICKEN & FRIES	4:00
<MORE ▲>	
▲, ▼ START TO SELECT	

Preset properties that can be changed (refer to page 37)

- TIME
 - Cook Cycle Time
- TEMP
 - Cook Cycle Temperature
- NAME
 - Preset Name
- CTS
 - Cook Time Sensitivity (refer to page 31)
- FTS
 - Food Type Sensitivity (see above)
- DUAL LOAD TIME
 - Dual Load Time (refer to page 27)

FRENCH FRIES	
TIME:	3:00
TEMP:	350°F
NAME:	FRENCH FRIES
<MORE ▼>	
▲, ▼ START TO SELECT	

FRENCH FRIES	
CTS:	5
FTS:	3
DUAL LOAD TIME:	0:00
<MORE ▲>	
▲, ▼ START TO SELECT	

USER DEFINED OPTIONS (Continued)

USER COUNTERS

- COOK TIME
 - Accumulated cook cycle time in hours
- NUMBER OF CYCLES
 - Accumulated number of cook cycles
- ON TIME
 - Accumulated on time in hours
- RESET ALL
 - To reset all values to 0

USER COUNTERS	
COOK TIME:	0HR
NO. CYCLES:	0
ON TIME:	0HR
RESET ALL	
▲,▼ START TO SELECT	

PRESET COUNTERS

- NUMBER OF CYCLES
 - Accumulated number of cook cycles
- RESET ALL
 - To reset all values to 0

PRESET COUNTERS	
1: FRENCH FRIES	115
2: CHICKEN TENDERS	230
3: ONION RINGS	138
4: POPPERS	221
5: CHEESE BITES	121
<MORE ▼>	
▲,▼ START TO SELECT	

PRESET COUNTERS	
6: CORN DOGS	32
7: FISH FILLETS	56
8: CHICKEN WINGS	223
9: CHICKEN & FRIES	61
RESET ALL	
<MORE ▲>	
▲,▼ START TO SELECT	

TOTAL COUNTERS

- COOK TIME
 - Accumulated cook cycle times in hours, cannot be reset
- NUMBER OF CYCLES
 - Accumulated number of cook cycles, cannot be reset
- ON TIME
 - Accumulated on time in hours, cannot be reset

TOTAL COUNTERS	
COOK TIME:	0HR
NO. CYCLES:	0
ON TIME:	0HR
▲,▼ START TO SELECT	

USER DEFINED OPTIONS (Continued)

OPERATION TESTS (for service personnel)

- FANS
 - Use the arrow keys to turn fans on and off [note: oil temperature must be below 122°F (50°C)]
 - Monitor rpm and current values of each fan
- INTERLOCKS
 - To view interlocks and if they're open or closed
 - = Open, = Closed
- BASKET
 - Use the arrow keys to move basket up and down
- DRAWER
 - Use the arrow keys to move drawer in and out
- HEATER
 - For factory heater calibration. **Do not adjust.**
- DISPLAY
 - Use START and CANCEL to turn all the pixels of the LCD on and off
- CIRCUIT BOARD
 - Monitor the circuit board temperature

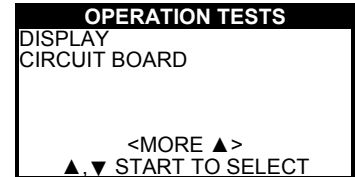
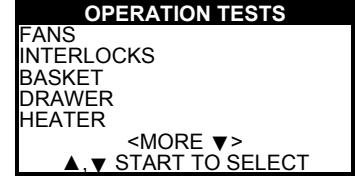

SET DEFAULTS

- Press start to reset options and presets to factory defaults
- PRESETS and UNITS will not change

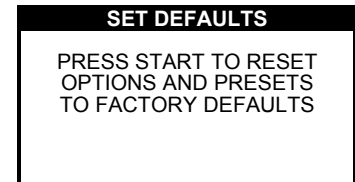

Option Changes (Example °F to °C)

SEE THIS LCD

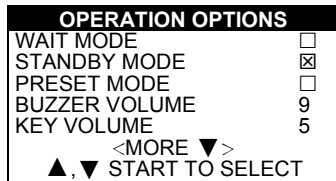

DO THIS

- 1) From OPERATION OPTIONS menu, scroll down to UNITS using key
- 2) Press **Start**

GET THIS LCD

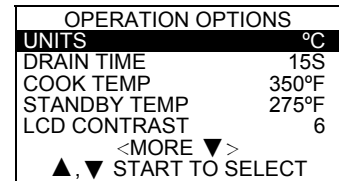

Note: All OPERATION OPTIONS menu items can be customized by following this basic procedure (some use the arrow keys).

USER DEFINED OPTIONS (Continued)

Customizing Presets

SEE THIS LCD

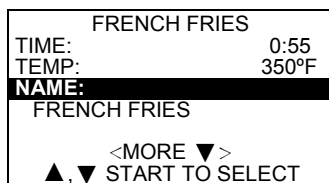
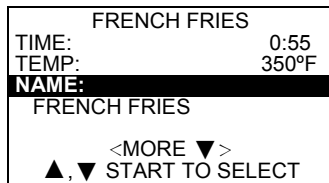
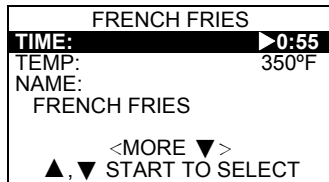
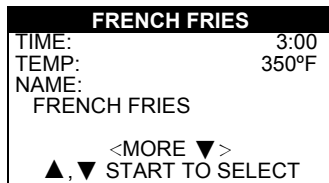
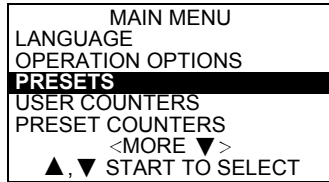

DO THIS

- 1) From main menu, scroll down to PRESETS using **▼** key
- 2) Press **Start**
- 3) Change PRESET 1's settings by scrolling down using the **▼** key
- 4) Press **Start**
- 5) Change PRESET 1's cook time by scrolling down using the **▼** key
- 6) Press **Start**
- 7) Set new COOK TIME (ex.: 55 seconds)
- 8) Press **5 5 Start**
- 9) Change PRESET 1's name by scrolling down with the **▼** key
- 10) Press **Start**
(A small cursor appears under first letter of the name PRESET 1.)
- 11) To change character above small cursor, use the **▼** and **▲** keys
- 12) Press **Start** to move forward
- 13) Press **Cancel** to move back
- 14) To enter your selection, press **Start** after underscore mark (_) appears
- 15) "QUICK FRIES" will now appear on bottom left of LCD during PRESET modes

GET THIS LCD

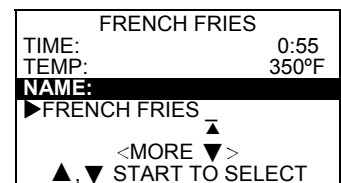
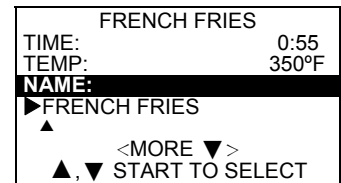
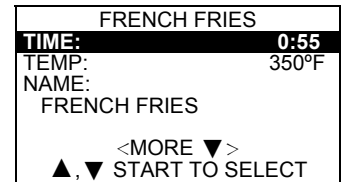
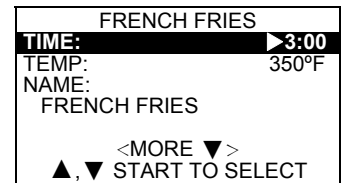
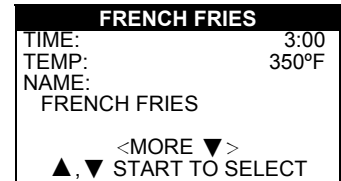

Note: maximum 20 characters







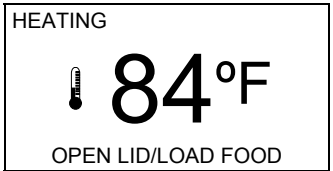

HELP

- Your PERFECT FRYER “beeps” twice to signal an error condition. When the error condition is corrected, two beeps signal OK.
- It is possible to have more than one SYSTEM ERROR displayed at the same time. When that happens, all error conditions will be displayed on the LCD. All must be corrected.
- When a SYSTEM ERROR condition exists, the PERFECT FRY de-energizes the heating element, but the fans continue to run.
- When there appears to be a problem, but no SYSTEM ERROR message is displayed, refer to the trouble-shooting table on page 40. If the solution suggested doesn't solve the problem, call your service rep. or PERFECT FRY at 1-603-225-6684.

System Error Conditions

SEE THIS LCD	CAUSED BY DO THIS	GET THIS LCD
	<ul style="list-style-type: none"> • <i>Hinged front panel is not installed or shut properly</i> • Check to see that front panel is closed securely with two black latches 	
	<ul style="list-style-type: none"> • <i>Air filter cartridge is not installed properly</i> • Check to make sure cartridge is properly installed (↑↑ up) in air filter cage, and cage is securely latched in place 	
	<ul style="list-style-type: none"> • <i>Grease filter is not installed properly</i> • Check to see that it sits in grease tray (magnet on right hand end of grease filter), and that filter and tray are properly installed in filter chamber 	
	<ul style="list-style-type: none"> • <i>Heating Element is not installed properly</i> • Check to see that heater module has been properly placed on oil vat • Check to see the electrical connection between heater module and connector is made at inside back of fryer compartment • Clean the male and female terminals on connector with rubbing alcohol and cotton swab. 	
	<ul style="list-style-type: none"> • <i>There is improper air flow</i> • Make sure air intake (front) and exhaust (rear) vents are not obstructed • Clean grease filter thoroughly • Replace the air filter cartridge 	
	<ul style="list-style-type: none"> • <i>Loss of pressure in the Fire Extinguisher, system needs to be recharged</i> • Call PERFECT FRY at 1-603-225-6684 for recommended fire Service Company near you. 	
	<ul style="list-style-type: none"> • <i>Heating Element is not installed properly</i> • Check to see that heater module has been properly placed on oil vat • Check to see the electrical connection between heater module and connector is made at inside back of fryer compartment • Clean the male and female terminals on connector with rubbing alcohol and cotton swab. 	

HELP (Continued)

SEE THIS LCD	CAUSED BY DO THIS	GET THIS LCD
<div style="border: 1px solid black; padding: 5px;"> <p>*** SYSTEM ERROR *** PLEASE CHECK SECONDARY OVERTEMP.</p> </div>	<ul style="list-style-type: none"> • <i>Cooking oil level is too low.</i> • Make sure oil level is between the hot and cold lines at rear of vat. • <i>Cooking oil has overheated.</i> • Press  and  keys together and release to reset • Is it possible the heater module was submerged in water? If so, call 1-603-225-6684 	<div style="border: 1px solid black; padding: 5px;"> <p>HEATING MANUAL</p> <p> 378°F</p> </div>
<div style="border: 1px solid black; padding: 5px;"> <p>*** SYSTEM ERROR *** PLEASE CHECK MAIN FAN</p> </div>	<ul style="list-style-type: none"> • <i>Main ventilation fan is not functioning properly</i> • Check main ventilation fan to see if it is moving air and the fan blades are moving • Remove obstruction and/or check electrical connection 	<div style="border: 1px solid black; padding: 5px;"> <p>HEATING MANUAL</p> <p> 84°F</p> <p>OPEN LID/LOAD FOOD</p> </div>
<div style="border: 1px solid black; padding: 5px;"> <p>*** SYSTEM ERROR *** PLEASE CHECK CONTROL FAN</p> </div>	<ul style="list-style-type: none"> • <i>Control fan is not functioning properly</i> • Check control fan to see if it is moving air and the fan blades are moving • Remove obstruction and/or check electrical connection 	<div style="border: 1px solid black; padding: 5px;"> <p>HEATING MANUAL</p> <p> 84°F</p> <p>OPEN LID/LOAD FOOD</p> </div>
<div style="border: 1px solid black; padding: 5px;"> <p>*** SYSTEM ERROR *** PLEASE CHECK EBOX FAN.</p> </div>	<ul style="list-style-type: none"> • <i>Electronics box fan is not functioning properly</i> • Check main ventilation fan to see if it is moving air and the fan blades are moving • Remove obstruction and/or check electrical connection 	<div style="border: 1px solid black; padding: 5px;"> <p>HEATING MANUAL</p> <p> 84°F</p> <p>OPEN LID/LOAD FOOD</p> </div>
<div style="border: 1px solid black; padding: 5px;"> <p>*** SYSTEM ERROR *** PLEASE CHECK DRAWER MOTOR</p> </div>	<ul style="list-style-type: none"> • <i>Drawer motor has been obstructed</i> 	<div style="border: 1px solid black; padding: 5px;"> <p>HEATING MANUAL</p> <p> 84°F</p> <p>OPEN LID/LOAD FOOD</p> </div>
<div style="border: 1px solid black; padding: 5px;"> <p>*** SYSTEM ERROR *** PLEASE CHECK BASKET MOTOR</p> </div>	<ul style="list-style-type: none"> • <i>Basket motor has been obstructed</i> 	<div style="border: 1px solid black; padding: 5px;"> <p>HEATING MANUAL</p> <p> 84°F</p> <p>OPEN LID/LOAD FOOD</p> </div>

HELP (Continued)**Trouble-shooting Table**

“PROBLEM”	PROBABLE CAUSE	PROBABLE SOLUTION
Won't turn ON when you press the  key	<ol style="list-style-type: none"> 1) Not plugged in 2) Circuit breaker or fuse 3) Wiring 	<ol style="list-style-type: none"> 1) Plug in fryer 2) Check circuit breaker or replace fuse 3) Make sure PERFECT FRYER is plugged in according to its electrical specifications (see page 4)
ON but will not heat	<ol style="list-style-type: none"> 1) Connector on heater module 2) Electronics box module 	<ol style="list-style-type: none"> 1) Replace heater module 2) Replace electronics box module
Motors will not move drawer or basket.	<ol style="list-style-type: none"> 1) Basket not installed properly 2) Front panel/drawer not installed properly 3) Basket motor not working 4) Drawer motor not working 	<ol style="list-style-type: none"> 1) Make sure that the basket is installed properly (see page 10) 2) Check wiring 3) Replace motor
Outer surface is unusually hot	<ol style="list-style-type: none"> 1) Dirty grease filter 2) Air filter cartridge plugged 3) Fans not operating 	<ol style="list-style-type: none"> 1) Remove and clean grease filter 2) Replace air filter cartridge 3) Check rear of fryer for air flow
Cooking oil spills into spill tray, excessively	<ol style="list-style-type: none"> 1) Too much oil in vat 2) Too much ice or water in food 3) Too much food in basket 4) Oil has reached end of its life 5) Drain valve is open 	<ol style="list-style-type: none"> 1) Remove some oil (when oil is cold it should not be above cold oil line inside vat) 2) Cook only frozen foods recommended for use in deep fryers; remove excess ice from food before placing food in basket 3) Do not fill food above top of basket 4) Change oil 5) Close valve
Food floats out of basket	<ol style="list-style-type: none"> 1) Too much cooking oil in vat. 	<ol style="list-style-type: none"> 1) Remove some oil; do not fill above cold oil line.
Excessive smoking	<ol style="list-style-type: none"> 1) Oil has “broken down” 2) Moisture 	<ol style="list-style-type: none"> 1) Replace the cooking oil 2) Too much moisture or ice crystals
Excessive foaming	<ol style="list-style-type: none"> 1) Soap residue 2) Oil has “broken down” 	<ol style="list-style-type: none"> 1) Rinse parts with vinegar solution 2) Replace the cooking oil
Food does not come out	<ol style="list-style-type: none"> 1) Too much food was inserted using a dual load or manual drawer 2) The basket was not installed or installed correctly 3) Large volume of heavily battered product was cooked 	<ol style="list-style-type: none"> 1) Only enter the amount of food that totals one drawer full per cook cycle 2) Make sure that the basket is installed properly (see page 10) 3) Try adjusting FTS value to 5 (see page 33)
Food does not go in	<ol style="list-style-type: none"> 1) Too much food was inserted 2) Front panel is not closed properly 3) Drawer shovel was not installed correctly 	<ol style="list-style-type: none"> 1) Do not overfill the drawer 2) Close front panel fully and latch closed 3) Install drawer shovel properly (see page 13)

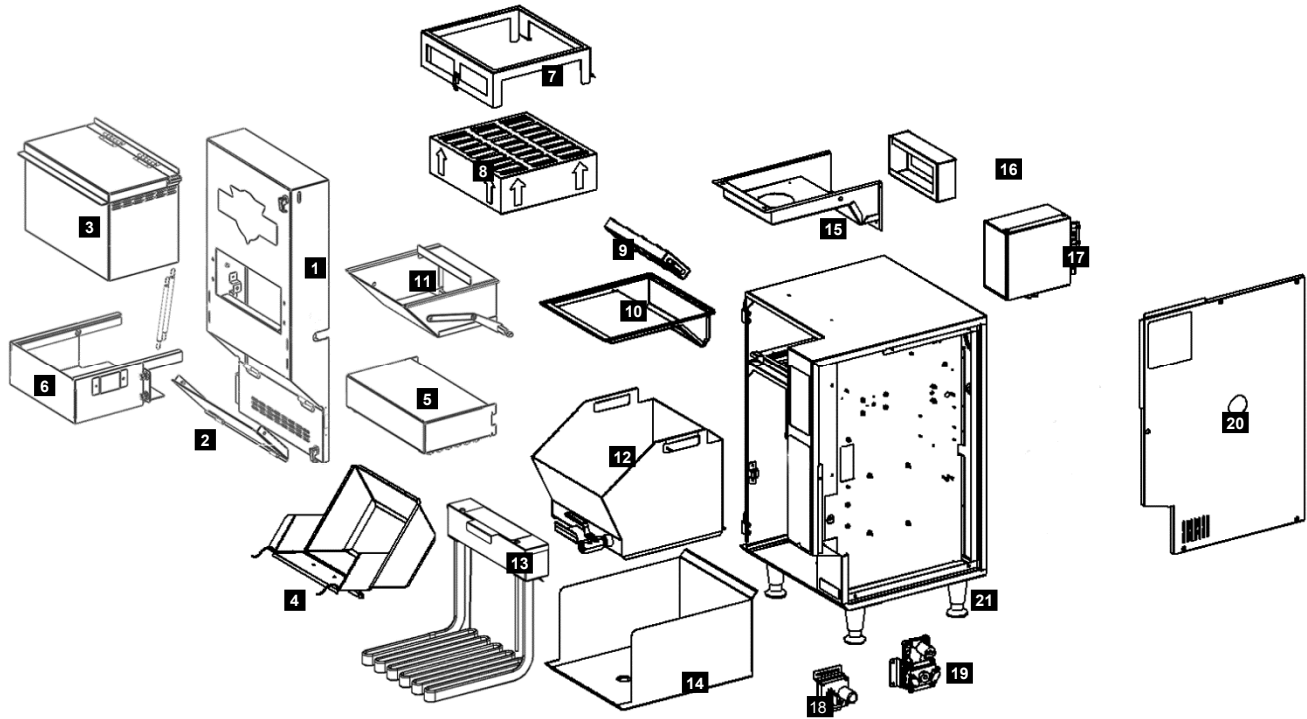

Item	Description	Part #
1	Front Panel	6SA002
2	Basket Ramp	6SA021
3	Drawer Cover	6SA011
4	Basket	6HA001
5	Heat Lamp	Please call
6	Drawer Sleeve	6SA010
7	Filter Cage	6ST730
8	Air Filter Cartridge	2FV803
9	Grease Filter Assembly	3HT727
10	Grease Filter Tray	6ST728
11	Drawer Shovel	6SA009
12	Oil Vat	6SA003
13	Heater Module 7200W/240V	2EA001
NS	Heater Module 5700W/240V	8ET900
NS	Heater Module 5700W/208V	2ET922
NS	Heater Module 3750W/240V	2ET763
14	Spill Tray	6SA022
15	Airflow Module	2HT723
16	Fire Damper	6HT588
17	Electronics Box Module	2WS800

Item	Description	Part #
18	Motor Module - Drawer	2HA001
19	Motor Module - Basket	2HA002
20	Control Access Panel Assembly	6SA014
21	Leg	6HA003
NS	Blow-off Cap	6GT014
NS	Hose Oil Drainage	6HT739
NS	Kit Basket PFA	2DT940
NS	Kit Front Panel	2DT950
NS	Kit Control Fan	2DT952
NS	Kit Main Fan	2DT951
NS	Kit Air Filter Switch Assembly	2DT955
NS	Kit Grease Filter Switch	2DT954
NS	Kit Door Switch	2DT954
NS	Kit Front Panel Switch	2DT953
NS	Airflow Switch	6HT646
NS	Gasket - Front Perimeter	2DT965

DECLARATION OF CONFORMITY

(FOR CE PERFECT FRYERS ONLY)

Application of Council Directive(s): Low Voltage Directive (93/68/EEC & 72/23/EEC)
EMC Directive (2004/108/EC & 89/336/EEC)
WEEE Directive (2002/96/EC)

Standard(s) to which Conformity is declared: EN 60335-1, EN 60335-2-37
EN 61000-6-1, EN 61000-6-3

Manufacturer's Name: Perfect Fry Company

Manufacturer's Address: P.O. Box 501
Concord, NH USA
03302-0501

Importer's Name: _____

Importer's Address: _____

Type of Equipment: Commercial Electric Deep Fat Fryer

Model Number: _____

Serial Number: _____

Year of Manufacture: _____

I, the undersigned, hereby declare that the equipment specified above conforms to the above Directive(s) and Standard(s)

Place: Perfect Fry Company LLC.
Concord, NH, USA

Date: ___/___/___

_____ (Signature)

_____ (Full Name)

_____ (Position)

THE PERFECT FRY 1 2 3 WARRANTY

2 years **Parts**

During the first 2 years after purchase, all parts of the fryer which prove to be defective in materials or workmanship will be replaced free of charge (parts only).

3 years **Electronics**

During the first 3 years after purchase, if the electronics module proves to be defective in materials or workmanship, it will be replaced free of charge (parts only).

TERMS OF WARRANTY

- 1) Perfect Fry Company LLC. warrants this fryer to be free from defects in materials and workmanship and will repair or replace it at Perfect Fry Company LLC.'s option for a period of two years after purchase providing the purchaser follows the manufacturer's recommended procedures for operation and maintenance contained in this manual. Perfect Fry Company LLC. shall not be liable for injury or damage to property other than this fryer.
- 2) The warranty applies to materials at the factory for two years (3 years electronics) from date of purchase. The warranty does not include materials and labor employed in cleaning the fryer. Any and all transportation and shipping charges and expenses are the responsibility of the Purchaser. The warranty card must be completed and registered with Perfect Fry Company LLC. within 30 days of purchase to validate the warranty. The warranty will cease to exist if maintenance has not been performed according to the manufacturer's instructions. This warranty does not cover damage arising from or caused by improper maintenance, directly or indirectly, transportation, accident, misuse, improper installation, fire, flood, or acts of God. Parts repaired or replaced under this warranty are warranted throughout the remainder of the original warranty period only. The warranty does not apply to parts and service supplied or obtained from other than Perfect Fry or its authorized distributors.
- 3) Other than the warranty expressed in clause 1) hereof, Perfect Fry Company LLC. expressly disclaims all conditions and warranties, express or implied, including, without limitation, the implied warranties of merchantability and fitness for a particular purpose. Perfect Fry shall not be responsible for, nor does this warranty extend to, any consequential or incidental damages or expenses of any kind or nature, regardless of the cause thereof or any knowledge which Perfect Fry may have regarding the probability of the occurrence of such damages or expenses including, without limitation, injury to persons or property, loss of life, loss of use of the products, lost goodwill, loss of income, lost resale profits, work stoppage, impairment of other goods, breach of contract, negligence or such other actions as may be deemed or alleged to be the cause of a loss or damage.



Perfect Fry Company LLC.
Mailing Address: P.O. Box 501, Concord, NH 03302-0501
Shipping Address: 10 Ferry St., Concord, NH 03301

Tel: 603-225-6684
Fax: 603-225-8472
General Information: profits@perfectfry.com
Customer Support: service@perfectfry.com
Internet: www.perfectfry.com

© 2013 PERFECT FRY COMPANY LLC
PRINTED IN USA
L20-395 R2