

INSTRUCTION MANUAL

SPITFIRE OVEN

SERIAL NUMBER

()

This manual should remain with the oven. It is the property of the end user.



Intertek



Intertek

This page has been left blank intentionally.

WARNINGS

WHAT TO DO IF YOU SMELL GAS?

1. IMMEDIATELY CLOSE THE MANUAL GAS VALVE.
2. DO NOT TRY TO TURN ON ANY APPLIANCES.
3. DO NOT TOUCH ANY ELECTRICAL SWITCHES; DO NOT USE A TELEPHONE IN YOUR LOCAL.
4. IMMEDIATELY CONTACT YOUR GAS SUPPLIER USING A NEIGHBOR'S PHONE.
5. IF YOU CAN NOT REACH YOUR GAS SUPPLIER, CONTACT THE FIRE DEPARTMENT.

FOR YOUR SAFETY:

DO NOT STORE OR USE GASOLINE, OTHER FLAMMABLE VAPORS OR LIQUIDS IN THE VICINITY OF THIS, OR ANY OTHER APPLIANCE

NOTE

THIS MANUAL SHOULD BE KEPT FOR FUTURE REFERENCE.
STORE IT SOMEWHERE EASILY ACCESSIBLE.

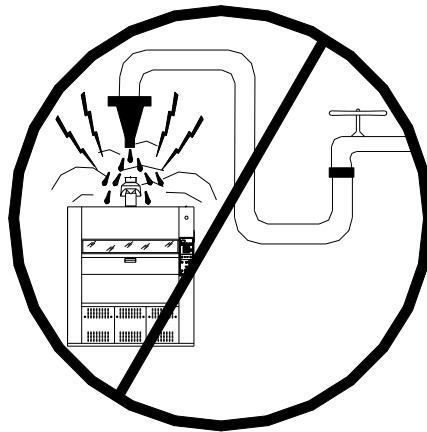

WARNING

DO NOT SPRAY LIQUIDS OR VAPORS ON, OR NEAR, ELECTRICAL EQUIPMENT. DO NOT USE THIS APPLIANCE IF ANY OF ITS PARTS HAVE BEEN UNDER WATER. IMMEDIATELY CONTACT A QUALIFIED SERVICE TECHNICIAN TO INSPECT THE APPLIANCE AND TO REPLACE ANY PARTS OF THE CONTROL SYSTEM AND GAS CONTROL SYSTEM WHICH WERE SUBMERGED UNDER WATER.

This page has been left blank intentionally.

REQUIREMENTS, WARNINGS AND RECOMMENDATIONS

WARNING!

All installation and/or service on this PICARD REVOLVING OVEN must be performed by qualified, certified, licensed and/or authorized installation or technical service personnel. All electrical, gas and plumbing connections must be made by authorized technicians and in compliance with all electrical, gas, plumbing and safety requirements.

It is possible to obtain these services by contacting PICARD OVENS INC, customer service, a sales representative or a local service agency.

DEFINITIONS:

QUALIFIED AND/OR AUTHORIZED GAS TECHNICIAN:

Qualified or authorized operating personnel are those who have carefully read the information in this manual or those who have experience operating the type of equipment covered in this manual and are familiar with the equipment's functions

QUALIFIED INSTALLATION TECHNICIAN:

A qualified installation technician can be represented by; an individual, a firm, a corporation or a company which, either in person or through a representative is involved and is responsible for:

The installation of gas piping from the outlet side of the gas meter or service regulator when a meter is not present and the connection and installation of the gas appliance. The qualified installation technician must be experienced in such work, be familiar with all necessary precautions, and have complied with all requirements of state or local authorities having jurisdiction. Reference in Canada: Canadian Standard CAN/CSA-B149.1 and Z223.1 / NFPA 54 (Natural and/or propane gas installation code)

The installation of electrical wiring from an electric meter, main control box or from the service outlet of an electrical appliance. A qualified installation technician must be experienced in such work, be familiar with all necessary precautions, and have complied with all requirements of state or local authorities having jurisdiction.

The appliance, when installed, must be electrically grounded in accordance with local codes, or in the absence of local codes, with the National Electrical code ANSI/NFPA 70, or the Canadian Electrical code, CSAC22.1 No 109 or conform to UL STD 197. You will find the electrical diagrams on the back cover of the gray electrical box of the oven. This box is located behind the front right stainless steel door. You can also refer to the electrical diagram starting at the back of this manual.

This page has been left blank intentionally.

LABELS YOU WILL FIND ON YOUR OVEN:

**ATTENTION BRÛLANT
CAUTION HOT**

DANGER – AVERTISSEMENT

Ne jamais mettre vos mains dans le four lorsque les tablettes sont en mouvement. Enfourner et défourner seulement lorsque les tablettes sont complètement arrêtées

Never put your hand in the oven while the shelves are moving. Load and unload only when the shelves are stopped.

IMPORTANT

COOK ONLY PIZZAS AND / OR BREADS DIRECTLY UPON THE BAKING STONE. ALWAYS COOK ALL OTHER FOODSTUFF IN PROPER COOKING RECEPTACLES.

CUIRE SEULEMENT LES PIZZAS OU LES PAINS DIRECTEMENT SUR LA SOLE. TOUTES AUTRES NOURRITURES DOIVENT ÊTRE CUITES DANS UN RÉCIPIENT APPROPRIÉ

WARNING/ ATTENTION

IF ALARM SIGNAL (BUZZER) SOUNDS, APPLICANCE IS MALFUNCTIONING. TURN OFF AND/OR DISCONNECT FROM POWER SUPPLY AND SEE INSTRUCTION MANUAL BEFORE OPERATING.

SI LE SIGNAL D'ALARME (SONNETTE) ÉMET UN SON, L'APPAREIL ÉPROUVE UN MAUVAIS FONCTIONNEMENT. FERMEZ LE FOUR ET/OU DÉCONNECTEZ-LE, ENSUITE VÉRIFIER LE MANUEL D'INSTRUCTION AVANT DE REPARTIR LE FOUR.

WARNING

DISCONNECT POWER SUPPLY BEFORE SERVICING AND MAINTENANCE.

AVERTISSEMENT

COUPER L'ALIMENTATION AVANT L'ENTRETIEN ET LE DÉPANNAGE.

FOR STEAM OPTION

IMPORTANT

This equipment is to be installed with adequate backflow protection to comply with applicable federal, state, and local codes.

Cet équipement doit être installé avec une protection d'anti retour adéquat pour être en conformité avec les codes fédéraux, d'état et locaux.

This page has been left blank intentionally.



PICARD

PICARD OVENS • FOURS PICARD
QUÉBEC, CANADA
WWW.PICARDOVENS.COM

REVOLVING TRAY OVEN / FOUR ROTATIF

MODEL / MODÈLE : _____

SERIAL / SÉRIE : _____

GAS / GAZ : _____

INPUT / DÉBIT (BTU / H) : _____

MANIFOLD PRESSURE /
PRESSION D'ÉCHAP. : _____

LINE PRESSURE /
PRESSION D'ENTRÉE : _____

NOZZLE / ORIFICE : _____

VOLTAGE / VOLTAGE : _____

AMPS / AMP. : _____

H.P. / C.V. : _____

CLEARANCES TO COMBUSTIBLES / DÉGAGEMENT AUX COMBUSTIBLES

	COMBUSTIBLE AND NON-COMBUSTIBLE MATERIAL	MATÉRIEL COMBUSTIBLE ET NON-COMBUSTIBLE	
TOP	16"	16"	DESSUS
BACK	0	0	ARRIÈRE
MANHOLE SIDE	24"	24"	CÔTÉ ACCÈS
OPPOSITE SIDE	0	0	AUTRE CÔTÉ
FLOOR	NON-COMBUSTIBLE ONLY	NON-COMBUSTIBLE SEULEMENT	PLANCHER

- INTENDED FOR OTHER THAN HOUSEHOLD USE.
- SUITABLE FOR CONNECTION TO TYPE A OR B GAS VENT.
- POUR UTILISATION AUTRE QUE DOMESTIQUE.
- PEUT ÊTRE INSTALLÉ AVEC UN EVENT À GAZ DE TYPE A OU B.

CERTIFIED TO / CERTIFIÉ À
CSA Std. 1.8-2006

CONFORM TO / CONFORME À
ANSI Std. Z83.11-2006
ANSI/NSF Std. 4-2009

**GAS FOOD SERVICE EQUIPMENT
ÉQUIPEMENT DE RESTAURATION À GAZ**



Intertek
9700551

MADE IN CANADA / FAIT AU CANADA



Intertek

This page has been left blank intentionally.

CONGRATULATIONS

YOU ARE NOW THE OWNER OF A PICARD REVOLVING OVEN

Regarding your business concerns, we are convinced that you will enjoy your equipment and on behalf of the company we do appreciate your choice.

Your new rotating-shelve oven was built using the latest technology and designed with production proven reliability. A team of experienced technicians, committed to excellence, completed the construction of the approved equipment.

MANUFACTURING OVENS USING STATE OF THE ART TECHNOLOGIE

Rugged, efficient and easy to use, the Picard Revolving Oven is well known for its reliability and its exceptional baking. This oven is perfect for baking a variety of food products such as bread, cakes, cookies and other pastries.

PICARD OVENS INC. not only responds to the needs of mass production baking but also to those who wish to reduce their operating expenses.

The dedicated design of each one of their products gives you many years of utilization with a minimum maintenance.

FOR YOUR SAFETY, THIS OVEN IS CERTIFIED

Certified to:

CSA Std. 1.8-2006

Conform to:

ANSI Std. Z83.11-2006

ANSI/NSF STD. 4-2009



This page has been left blank intentionally.

TABLE OF CONTENTS

<u>OVEN INSTALLATION</u>	Pg 15
EXTERNAL OVEN DIMENSIONS	Pg 15
GENERAL OVEN COMPONENTS	Pg 16
MINIMAL DISTANCE REQUIRED BETWEEN THE OVEN AND FLAMMABLE MATERIAL	Pg 17
GAS CAPACITY AND PRESSURE	Pg 17
CONNECTION LOCATIONS	Pg 18
VENTILATION CONNECTION	Pg 18
PLUMBING CONNECTIONS	Pg 19
VENT CANOPY SEALING	Pg 20
TYPE OF INSTALLATION FOR VENTILATION SYSTEM	Pg 20
<u>RECOMMENDED UTILIZATION</u>	Pg 21
USAGE INSTRUCTIONS	Pg 21
OVEN START UP	Pg 21
PRODUCT LOADING	Pg 21
OVEN SHUT DOWN	Pg 21
CONTROL PANEL OPERATION	Pg 22
MAXIMUM HEIGHT FOR BAKING PRODUCTS	Pg 27
<u>GENERAL MAINTENANCE</u>	Pg 28
MAINTENANCE SCHEDULE	Pg 28
SPARE PARTS	Pg 29
NEON REPLACEMENT PROCEDURE	Pg 30
HOW TO OPEN THE CONTROL PANEL	Pg 30
PREHEATING THE BAKING STONE	Pg 31
HOW TO GLAZE THE SHELVES	Pg 31
SHELVE ALIGNMENT	Pg 32
TROUBLE SHOOTING	Pg 32
VERIFICATION LIST	Pg 33
ELECTRICAL DIAGRAMM	Pg 34
<u>LIMITED WARRANTY</u>	Pg 38

This page has been left blank intentionally.

SECTION : OVEN INSTALLATION

EXTERNAL DIMENSIONS

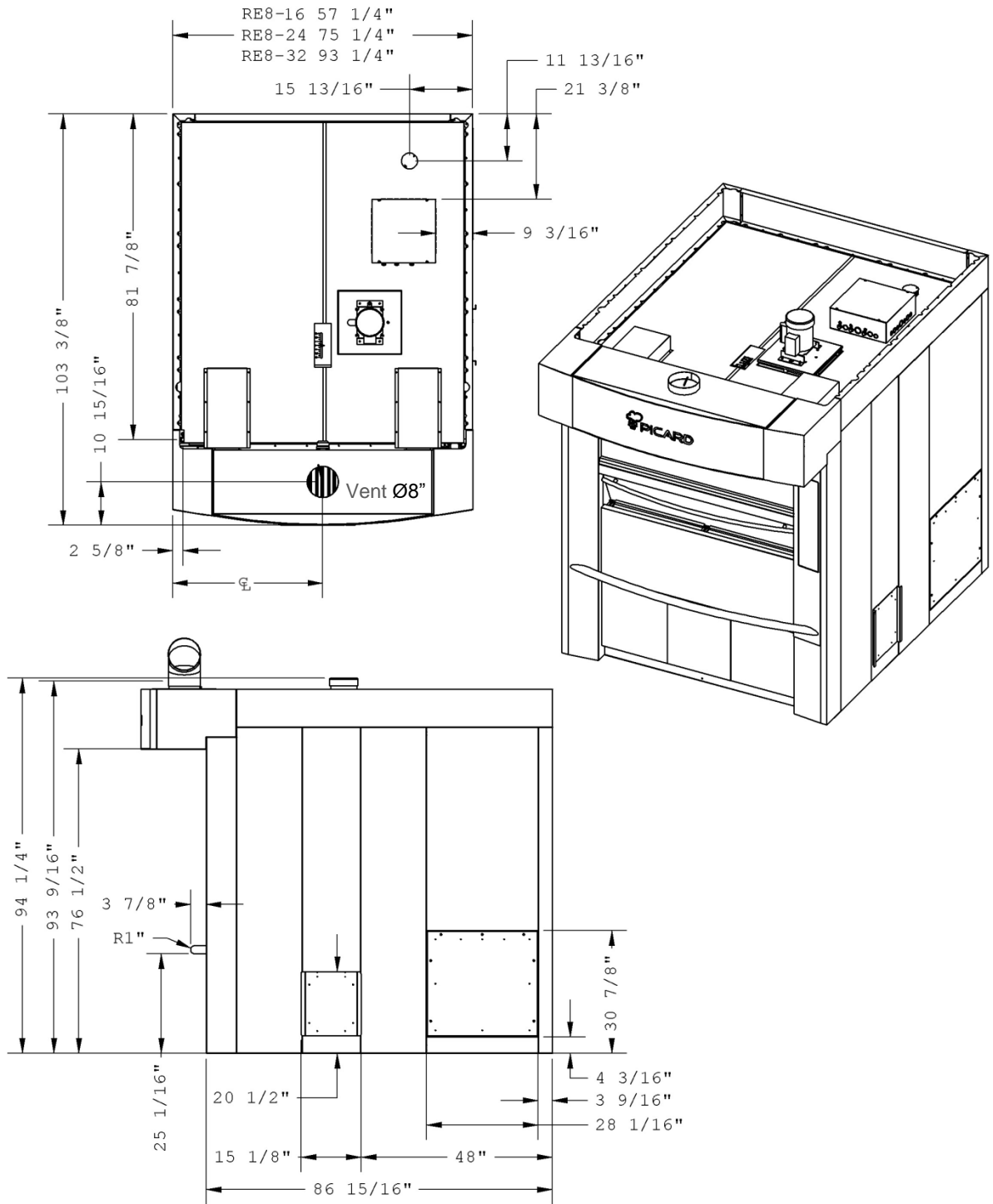

GENERAL COMPONENTS

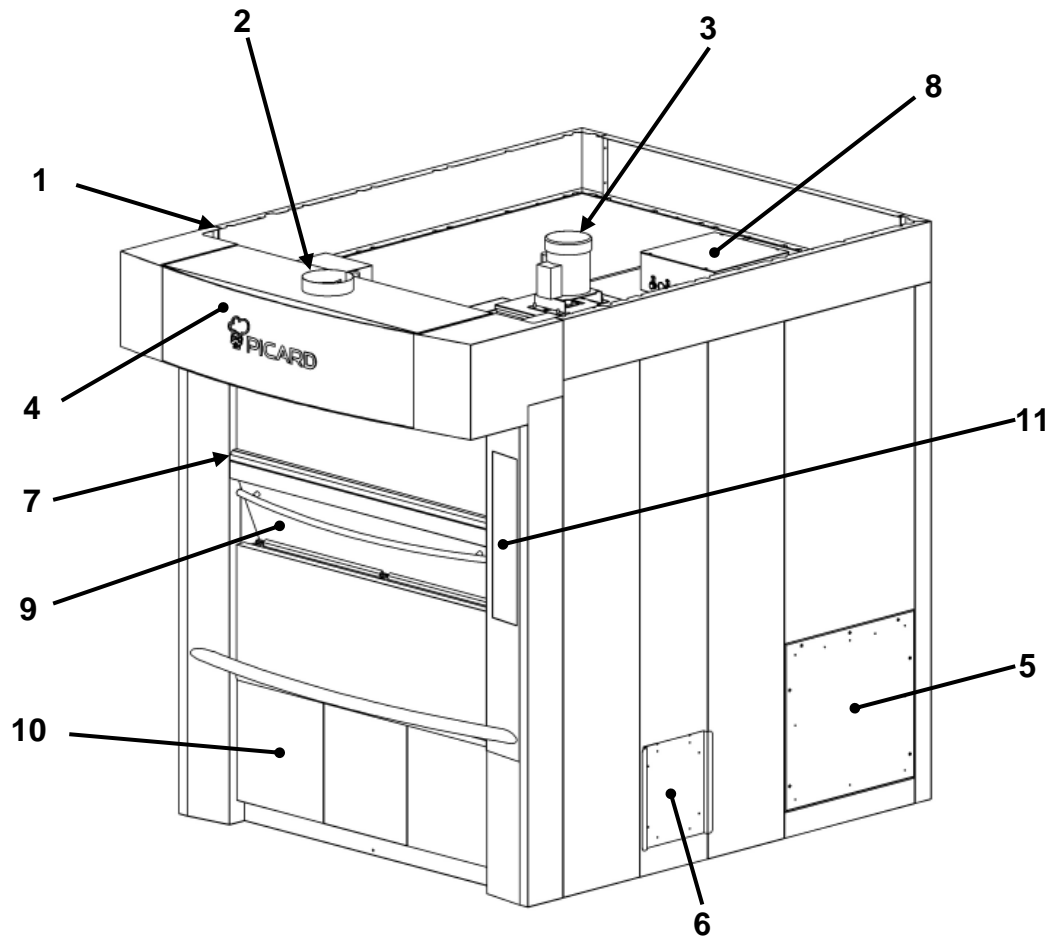

1. Gas hook- up: $\frac{3}{4}$ inch NPT. pipe
2. Vent – 8" diameter
3. Internal ventilation motor
4. Hood
5. Manhole
6. Cleaning access door
7. Light Access
8. Electrical box
9. Oven door
10. Electric-mechanic access panels
11. Control panel

MINIMAL DISTANCE REQUIRED BETWEEN THE OVEN AND FLAMMABLE MATERIAL

	COMBUSTIBLE AND NON-COMBUSTIBLE MATERIAL
Manhole side	24 inches of clearance
Ovens top	16 inches of clearance
Ovens back and side	0 inch of clearance
Ovens floor	0 inch of clearance non-combustible materiel only

GAS CAPACITY AND PRESSURE

MODEL	ORIFICE	TYPE OF GAS	CAPACITY BTU	LINE PRESSURE
SF-8-16	5.6mm	Propane	150,000	5" -14" W.C.
SF-8-16	5.6mm	Natural	150,000	
SF-8-24	7.5mm	Propane	200,000	
SF-8-24	7.5mm	Natural	200,000	

NOTE

Picard gas units are manufactured to only be used with the type of gas specified on the rating plates. The installation must conform to local codes, or in the absence of local codes, to the ANSI Z223.1 / NFPA 54 (National Fuel Gas Code) CAN/CSA-B149.1 (Natural and or propane gas installation code)

WARNING!

Improper installation, adjustment, alteration, service or maintenance could result in property damage, injury or even death!

IMPORTANT!

The high limit temperature alarm must always be adjusted to 625 degrees Fahrenheit or 330 degrees Celsius.

CONNECTIONS LOCATIONS

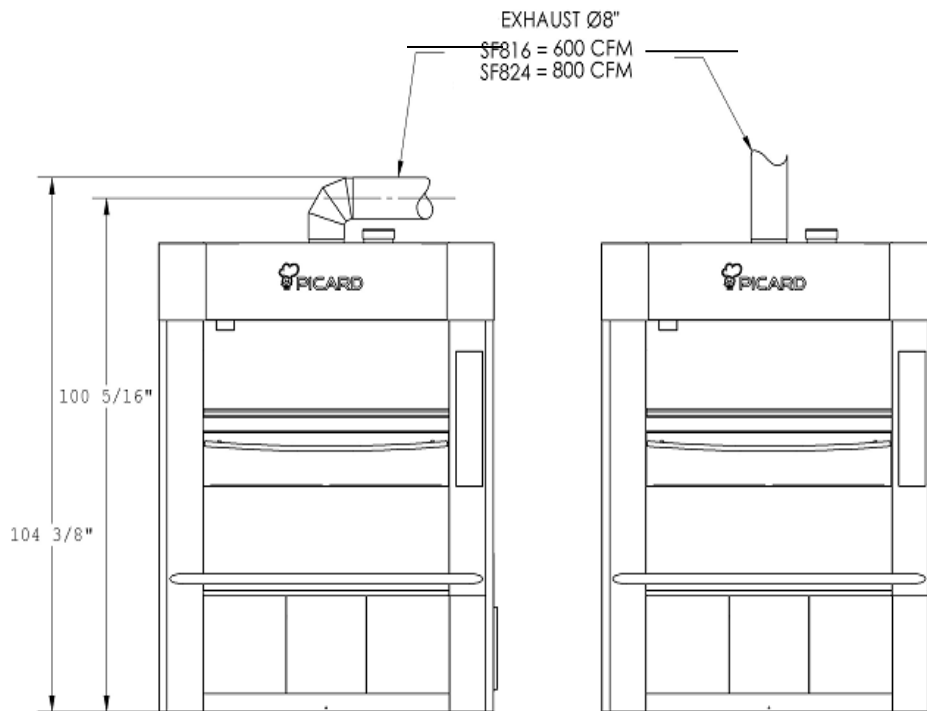
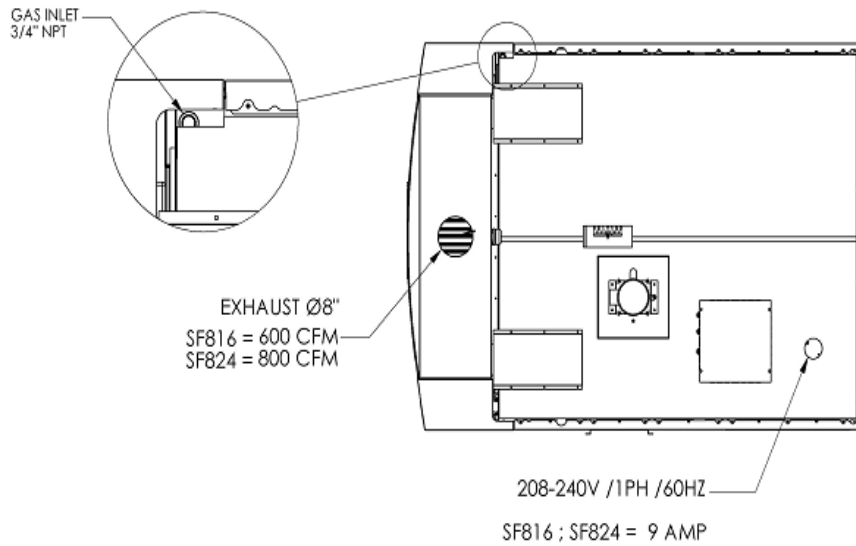

VENTILATION CONNECTION

This oven can be connected to a type "A" or "B" vent

IMPORTANT

All exhaust systems are required to have make-up air system that replaces 100% of the exhaust air. Windows, doors, or other openings into the establishment cannot be used for the purposes of providing make-up air.

WARNING

A negative pressure in the room or faulty installation of the chimney may damage electrical components which are not covered by the warranty.

PLUMBING CONNECTIONS

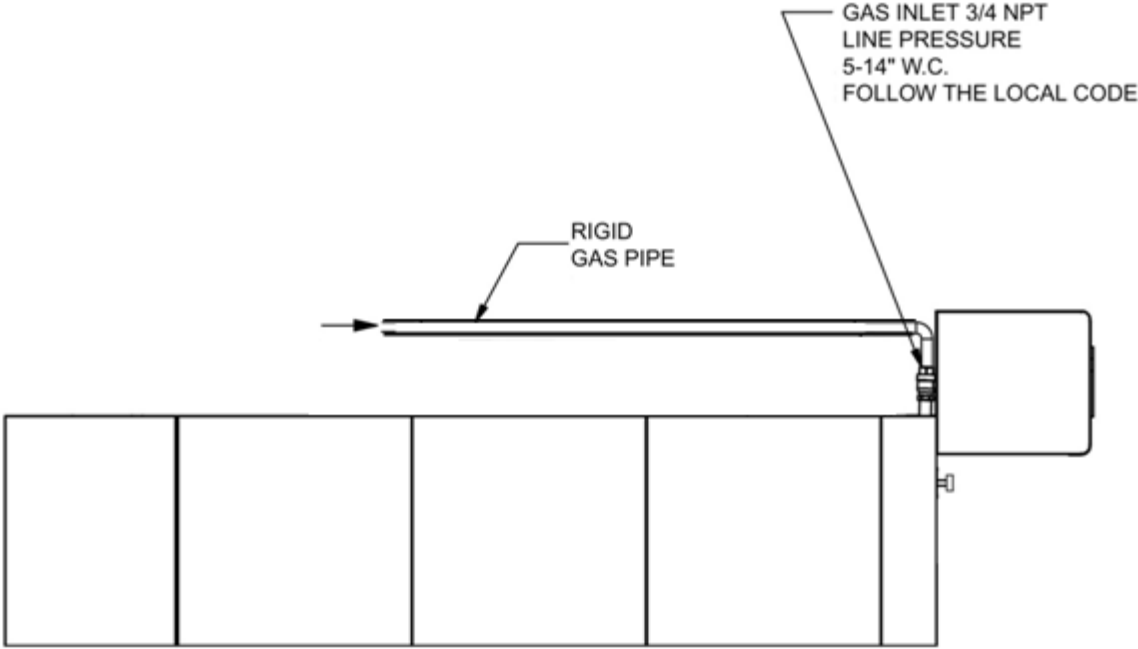

NOTE

The gas line size depends on the gas line length, refer to code

WARNING

All venting, and electrical hook ups must be in accordance with federal, state or local code and are the responsibility and cost of the client.

VENT CANOPY SEALING

Silicone must be applied to seal canopy to the oven as seen below.

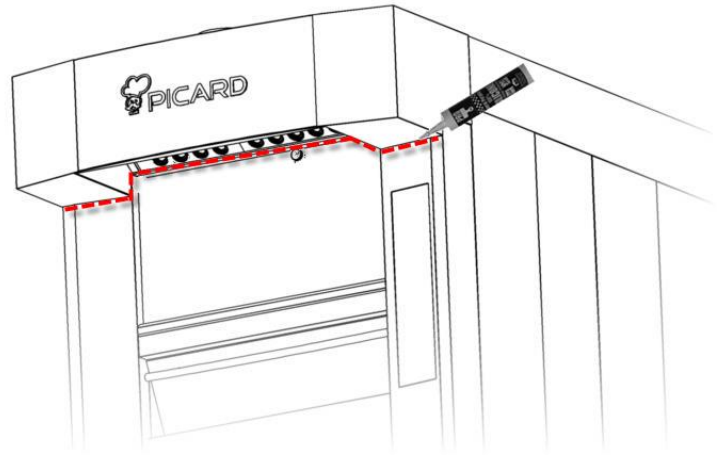

TYPE OF INSTALLATION FOR VENTILATION SYSTEM

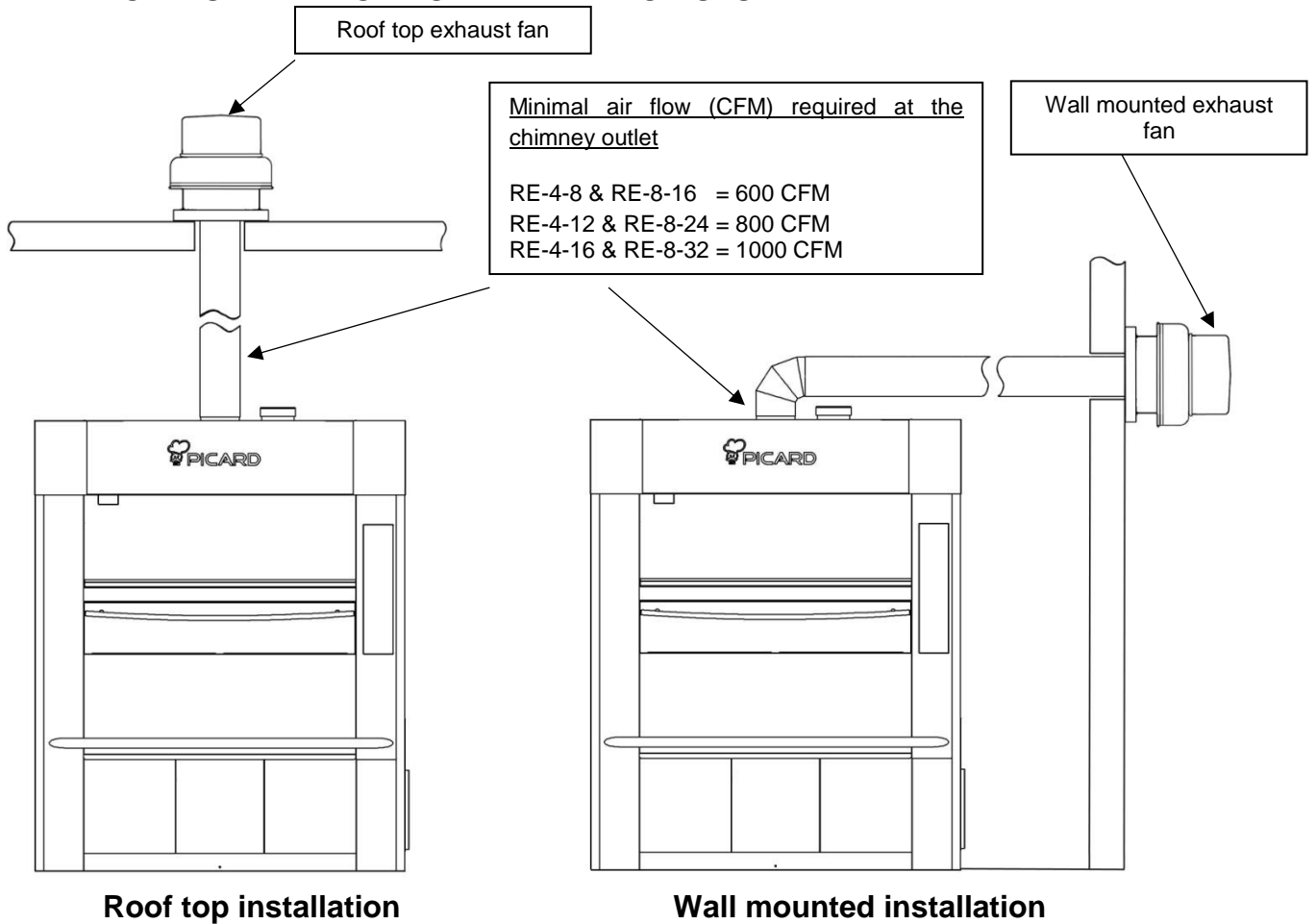

WARNING

All venting, plumbing and electrical hook ups must be in accordance with federal, state or local code. Type of exhaust fan must be selected by a professional because it can vary depending on the distance between the exhaust fan and the oven and the number of elbow fitting used.

WARNING

Built-in ovens require adequate ventilation in the area above the oven. The temperature above the oven should never exceed 105 ° F - 40 ° C !

A higher temperature will greatly affect the life of electrical components located on the oven's roof top. Component failure will not be covered by warranty in such cases.

SECTION : RECOMMENDED UTILIZATION

USAGE INSTRUCTIONS



BEFORE OPERATING, smell for gas odors around the appliance. Be sure to include close to the floor because some gases, like propane, are heavier than air and will settle on the floor.

START UP

(If you use an oven with stone shelves, see pg. 29)

1. Open the front access door to expose the electric box and turn the breaker to the on position. If the preset time icon, on the control panel is flashing, adjust the hour on the control panel using the timer arrows
2. Press the preset timer button to save settings. This only happens if there has been an electric power outage or at the first start up of the oven.
3. Press the ON/Off button.
4. Set the thermostat to the desired temperature.
5. Push the shelf rotation arrow to start the shelves revolving.
6. Make sure that heat evacuation outlet door is tightly closed, use the quick evacuation knob situated above the viewing window.
7. If you need to restart the oven, wait 5 minutes before beginning, making sure there is not any gas accumulated with in the oven.

PRODUCT LOADING

1. Make sure that the oven has reached the desired temperature, if so, follow the instructions below.
2. As needed and if you have the optional steam system press the push button "steam", following the wait cycle when the fan stops for approximately 2 minutes.
3. Stop the shelf at the door level.
4. Load the shelf evenly by putting more or less the same weight on each shelf. (Put the same number of pans on each shelf or the same weight. Pans must never exceeded the edge of the shelves)
5. Close the door, press the "steam" button once again only if you have this option (not mandatory).
6. To load the next shelf, activate the shelves upward, once the shelf stopped at the door level, load the shelf, close the door and press again the push button "steam" again and repeat for each shelf.
7. Set the timer to the desired baking time and start it.
8. If needed, to remove some steam, the user can open the heat evacuation outlet door with the quick evacuation knob situated above the viewing window. Afterwards, you must close it to keep the heat inside. We suggest opening the heat outlet door 2 or 3 minutes after the last steam injection. Keeping it open for 1 or 2 minutes, and then close it.

WARNING

The door must be closed during all the baking time.

SHUT DOWN INSTRUCTION

1. Open the heat outlet door with the quick evacuation knob to lower the oven temperature.
2. Close the burner with the on / off button.
3. After 5 to 10 minutes, stop the shelves rotation, push the red stop button.

WHAT TO DO IF YOU SMELL GAS?

1. Close immediately the manual gas valve.
2. Do not try to turn on any appliances.
3. Do not touch any electrical switch; do not use any phone in your building.
4. Immediately contact your gas supplier using a neighbor's phone. Follow the supplier's instructions.
5. If you cannot reach your gas supplier, contact the fire department.

This appliance does not have a permanent pilot. It has an electronic sparking unit.

Never try to ignite the burner by hand.

CONTROL PANEL OPERATION

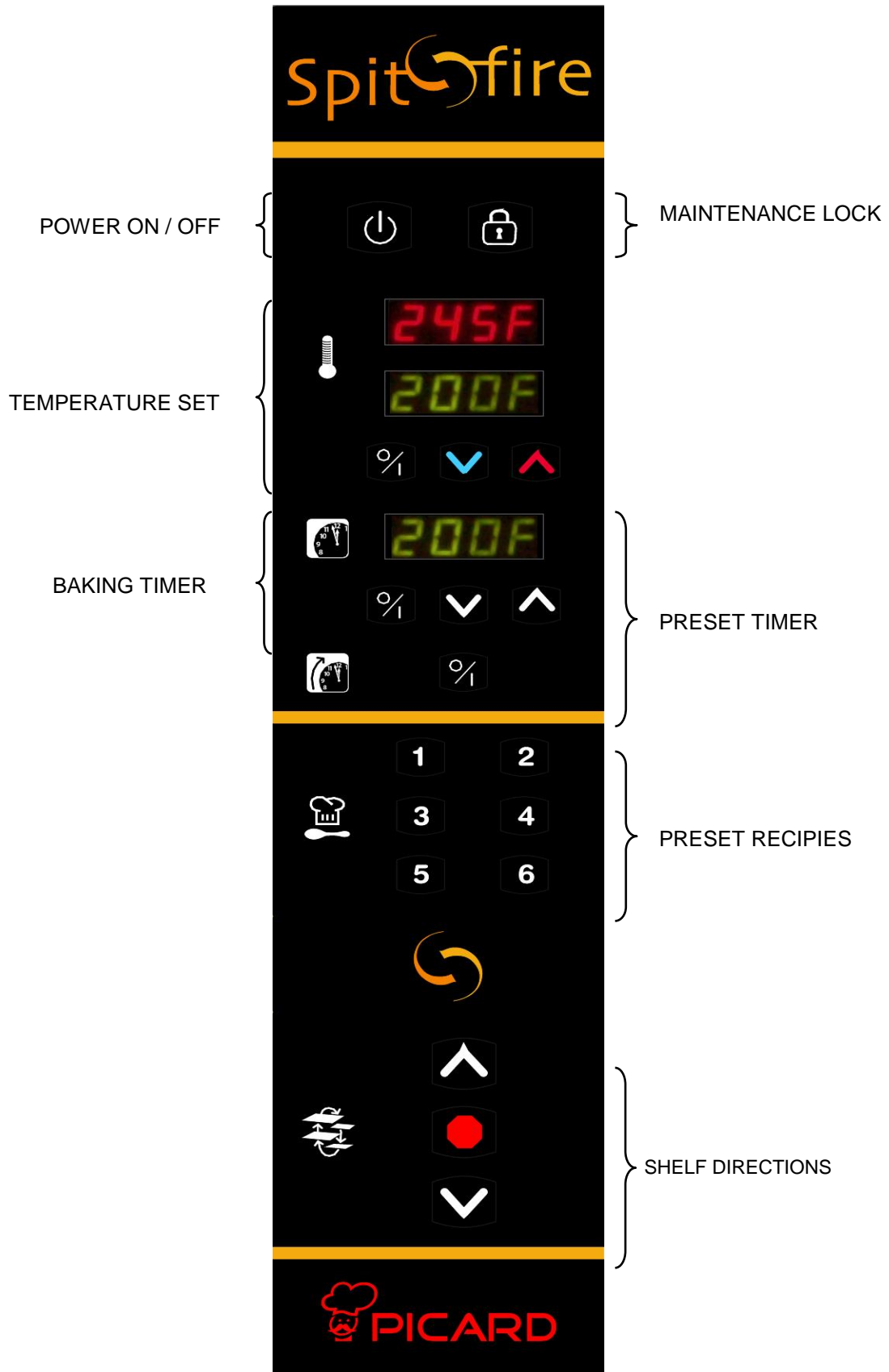

POWER AND LOCK BUTTON

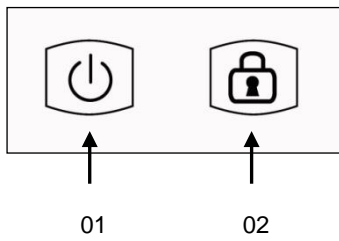

1. On and Off Button for the control Panel.
2. The maintenance lock button turns the control panel on and off. Push this button continually during 5 seconds to lock the oven functions.

NOTE

Once the oven is locked the icon will flash, indicating that someone is servicing the oven. The shelves and burner will not function until the maintenance lock button is pressed again for 5 seconds.

TEMPERATURE CONTROL

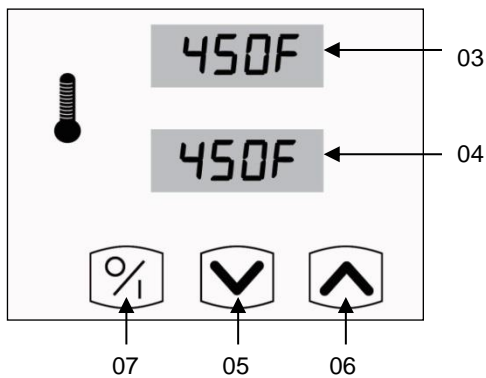

3. Displays the real internal temperature in the oven.
4. Displays the temperature configured in the settings.
5. Touch the blue arrow to lower the temperature setting.
6. Touch the red arrow to raise the temperature setting.
7. Press this button to start the burner.

F° TO C°

To change the temperature unit of measure from F° to C° or vice versa, hold the blue and red arrows #5 and #6 simultaneously until the reading in the temperature display changes.

BAKING TIMER

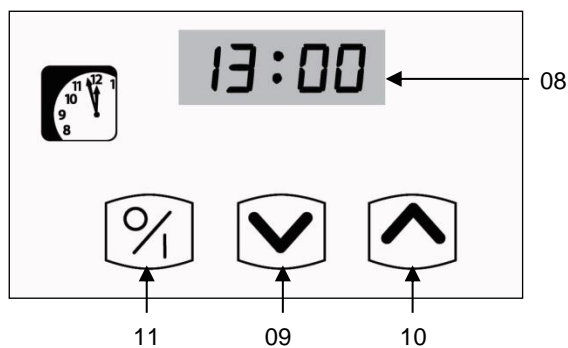

8. Shows the cooking time.
9. Touch the down arrow to reduce baking time.
10. Touch the up arrow to increase baking time.
11. Press this button to start or stop the timer.

The timer display shows 24 hour set cooking time and counts down by one second increments once the timing has begun.

PRESET TIMER

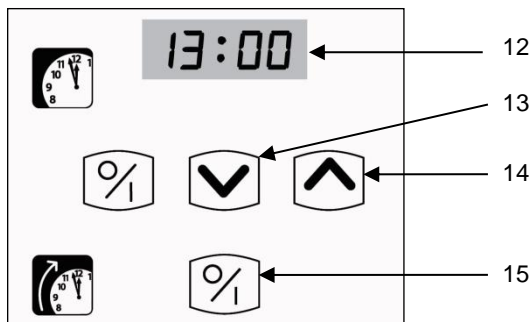

- 12. Displays the auto start time.
- 13. Touch the down arrow button to decrease the auto start time.
- 14. Touch the up arrow button to increase the auto start time.
- 15. Use this button to start or stop the preset timer function.

TIME ADJUSTMENT

- Press and hold the preset timer button #15 for 5 seconds. The lights will begin flashing.
- Adjust the timer if necessary with the timer arrow buttons #13 and #14.
- Press the preset timer button #15 again to save your settings.
- Hour display is in 24 hour format.
- The clock doesn't change automatically spring and fall.

PRESET TIMER USE

- Use the preset timer button #15 to begin the set-up.
- Use the preset arrows #13 and #14 to set the start up hour.
- Adjust the temperature required using the temperature arrow buttons #5 and #6.
- Press the power on / off button #1, to close the oven.
- Hour display is in 24 hour format.

make sure that :

RECIPE PRESETS

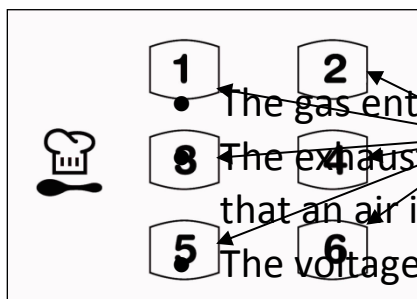

- The gas entry pressure is between 5 and 14 inches of water column.
- The exhaust canopy induction is adequate, between 600 and 1000 CFM that an air intake has been made.
- The voltage and amperage are in accordance with the name plate.

- The oven is level.

- The water hook-ups to the oven have been made for the steam option

SHELF ROTATION

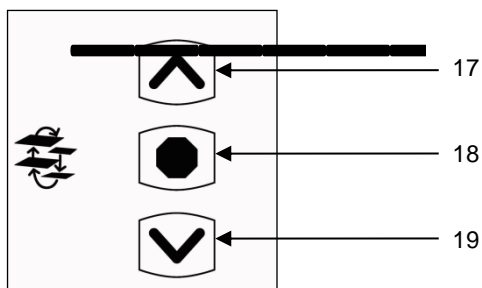

- 17. Touch this arrow to make the shelves turn upwards.
- 18. Use this button to stop the shelves rotation.
- 19. Touch this arrow to make the shelves turn downwards.

assurez-vous que :

NOTE

You must use the Stop button #18 before making a change in direction.

TOTAL OVEN USAGE TIME

Press simultaneously buttons #09 and #10. The Baking Time display will now display the oven's total usage time since its installation. (Each unit = 10 hours)

STOP THE INTERNAL FAN

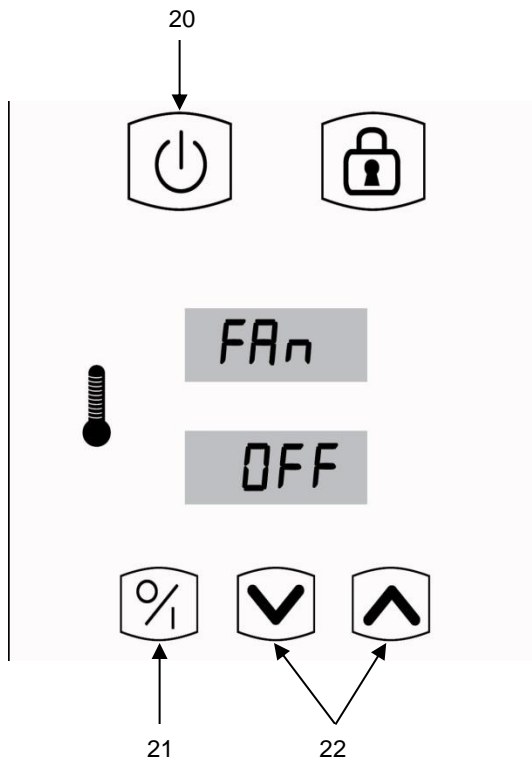

20. Turn the oven off completely by the power on/off key.
21. Touch the temperature set on/ off key for 5 seconds to activate the fan menu.
22. Use the up and down keys to turn on or off the fan.
21. Touch the temperature set on/ off key once again to confirm.
20. Restart the oven.

QUICK EVACUATION PULL KNOB

Quick evacuation pull knob to open or close the heat trap door.

NOTE

Pull this knob to evacuate heat. Push it to keep the heat inside the oven while baking.

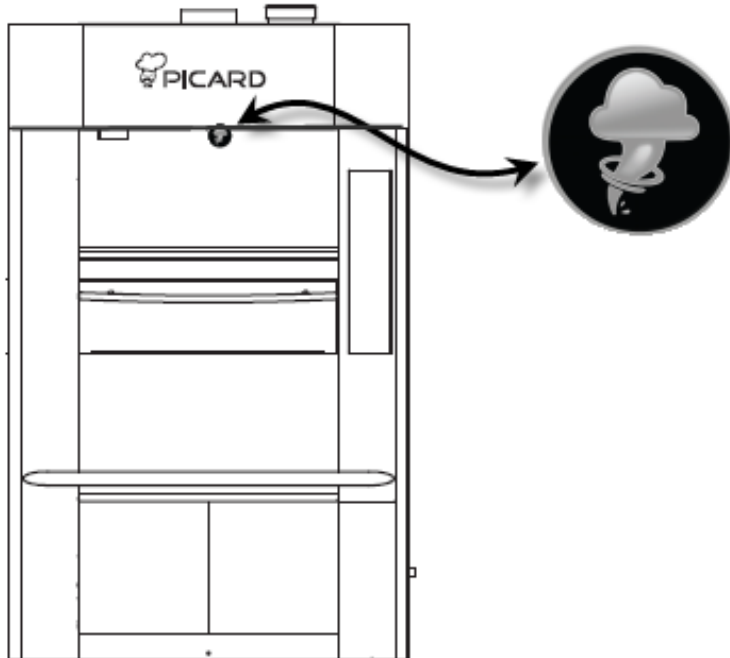

MAXIMUM HEIGHT FOR BAKING PRODUCTS

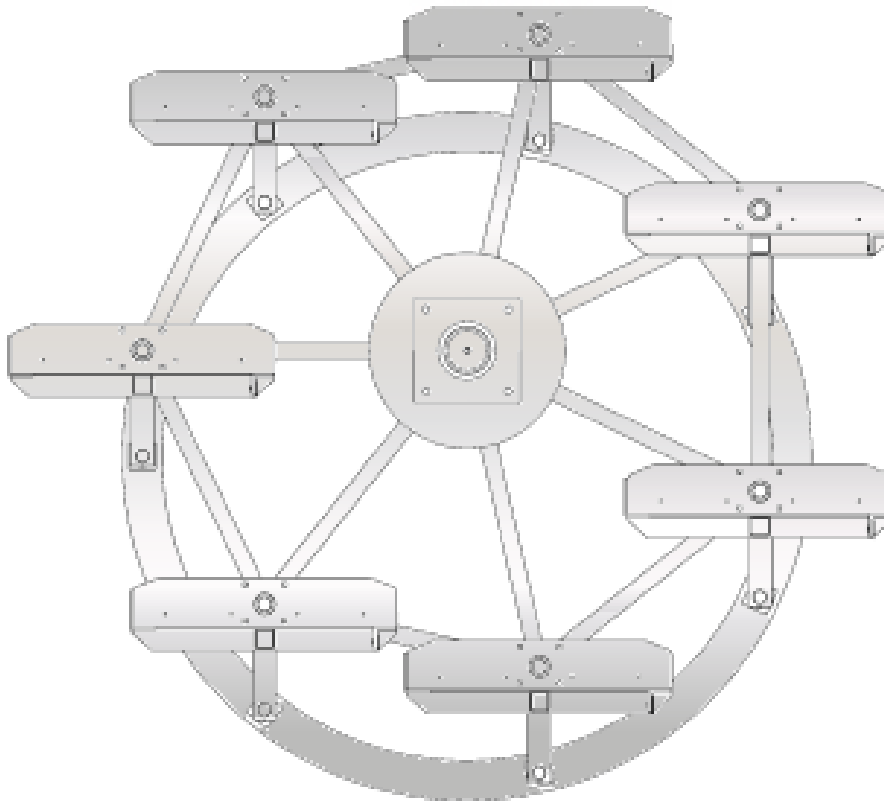

The maximum height for products on the shelves is 7 ½" from the front to the back.

Note: Shelves turn clockwise smoothly.

IMPORTANT

Baking trays should never exceed the edge of the shelves!

Failure to respect this rule may result in contact between trays and the inside oven walls causing severe damage to the shelves. Resulting damage will not be covered by warranty and will make the oven unusable.

SECTION : GENERAL MAINTENANCE

MAINTENANCE SCHEDULE

REFERENCE No	 IT IS VERY IMPORTANT TO DISCONNECT THE POWER SUPPLY BEFORE SERVICING AND MAINTENANCE	DAILY	EVERY MONTH	EVERY 6 MONTHS	ONCE A YEAR	TO BE CARREID OUT BY :
A	Replace oil from the gearbox. (Oil type, 80 W 90 SAE)				*	Distributor / Certified technician
B	Check the oil level of the gearbox.		*			Customer
C	Check the shelves's bushings.				*	Distributor / Certified technician
D	Check the oven's central axle bushings.				*	Distributor / Certified technician
E	Check the tension of the belt with your thumb. (1/4" max. deflection).			*		Customer
F	Change the motor's belt that activates the shelves.				*	Distributor / Certified technician
G	Add graphite oil or high temperature grease on the drive chain. <i>(Grainger 1-888-361-8649 item #4UJ38).</i>		*			Distributor / Certified technician
H	Clean the windows, on the inside and outside and shelves in the oven.	*				Customer
I	Remove the front side access panel and Vacuum the oven floor of any debris. <i>For high volume installations, the procedure could be repeated more often.</i>		*			Customer
J	Grease metal shelves with shortening as needed to prevent rusting.	AS NEEDED				Customer
K	Clean the motor's fan and the burner's fan.				*	Distributor / Certified technician
L	Vacuum on the Burner			*		Customer
M	Clean the burner air intake filter		*			Customer
N	Clean the spark electrodes and the flame rod. Use a scrubbing pad.			*		Customer / Certified technician

IMPORTANT

For repair or maintenance, contact the factory's customer service department, your sales representative or a local service agency.

www.picardovens.com

SPARE PARTS

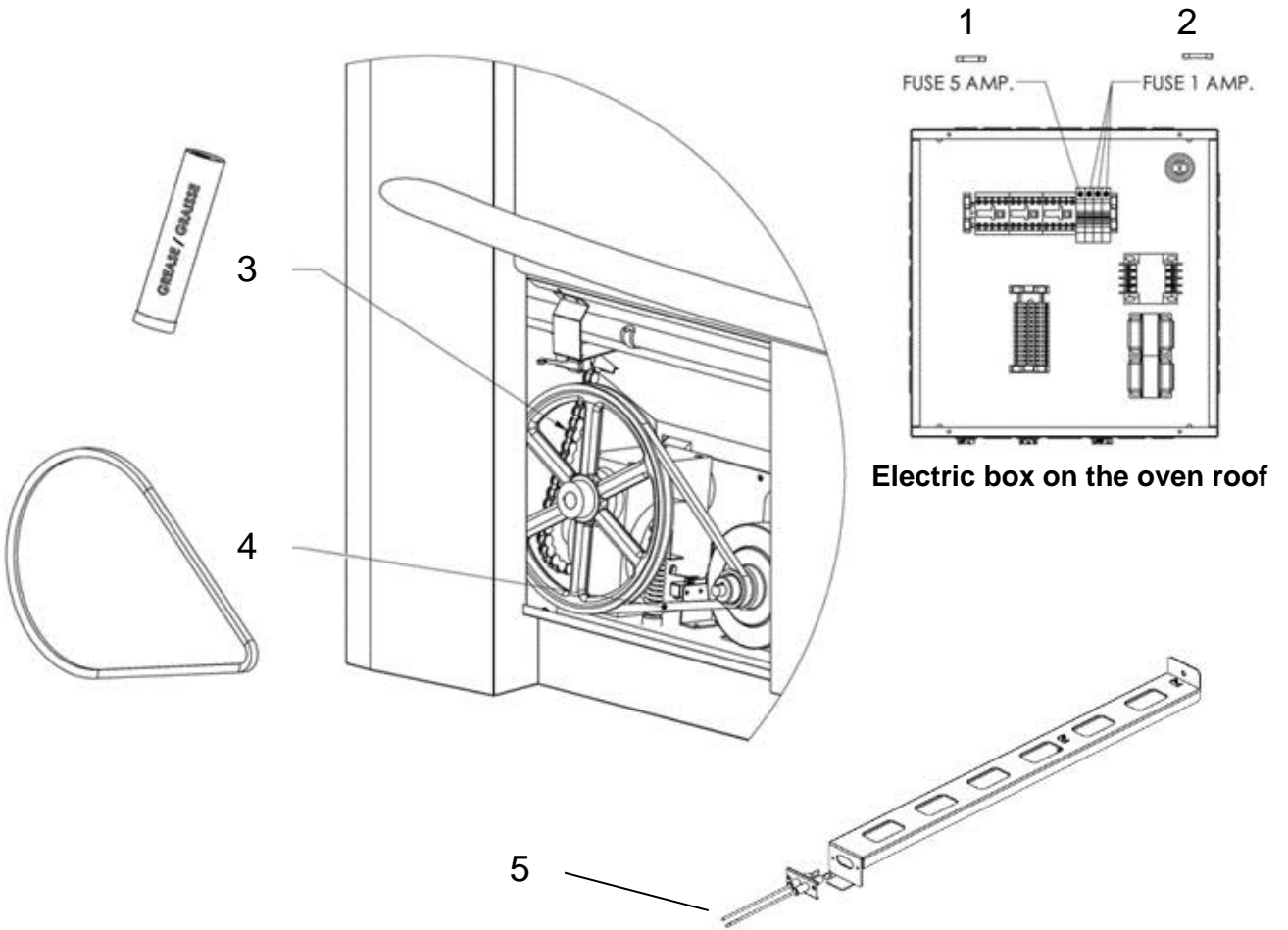

No	Quantity	Description	Part No.	Maintenance Reference
1	1	Fuse 5 amps	EL36-0006	
2	1	Fuse 1 amp	EL36-0044	
3	1	Tube of high temperature grease	FO75-0015	G
4	1	Belt	ME27-0023	E, F
5	1	SPARK and flame detector	PL69-0010	

NEON REPLACEMENT PROCEDURE

REMOVAL OF THE NEON SHIELD

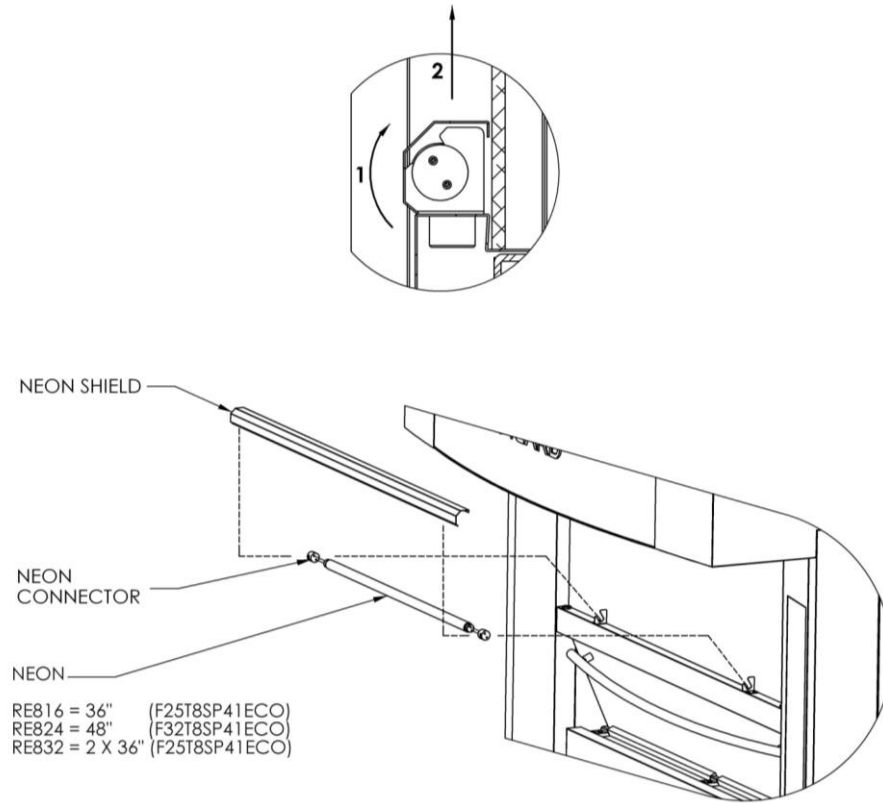

HOW TO OPEN THE CONTROL PANEL

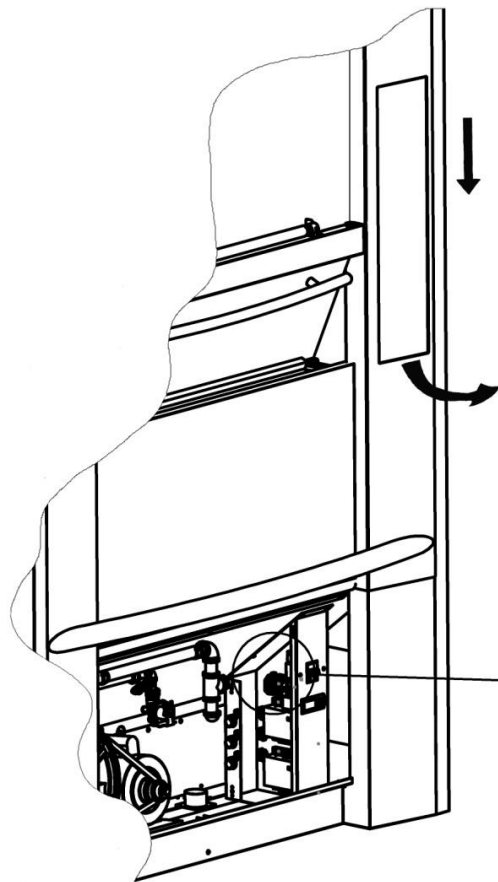

Only persons with required electrical knowledge may open the control panel.

1. Remove the side panel of the bottom electrical box. **Put one hand on the front control panel to prevent it from falling.** Pull on the release cable.
2. Pull out on the bottom of the control panel.
3. Pull down on the control panel to release the top.

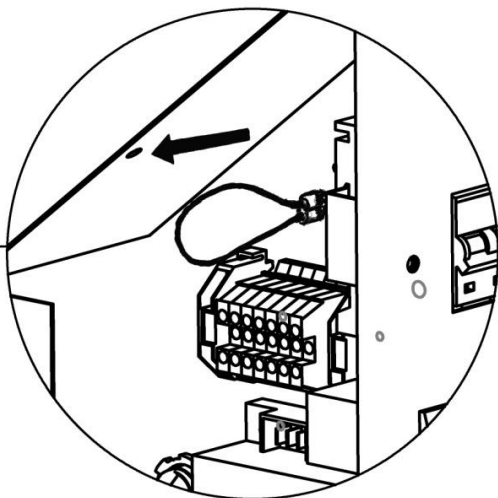

PREHEATING THE BAKING STONES

1. Let the stones come to room temperature before beginning the preheat exercise.

Keep the oven door closed at all times during this procedure!

1. Set the oven to 100°F (38°C) for four hours, the temperature will increase by itself until it reaches 250°F (121° C)
2. Increase the temperature to 300°F (149°C) for 1 hour.
3. After preheating the stones for 1 hour at 300°F (149°C), gradually increase the temperature by 50°F (10°C) per hour until 500°F (260°C) temperature is reached.

Do not alter this procedure!

Your oven is now ready to cook at the temperature you desire.

IMPORTANT

A failure to correctly preheat the stones can lead to warping, cracking, disintegration and even the stones exploding!

HOW TO GLAZE THE SHELVES (MAINTENANCE REFERENCE J)



TROUBLE SHOOTING

Problem	Cause	Solution
The oven won't turn on after pressing the main power button.	The oven has no electricity.	-Verify that the switch behind the bottom right side access door is in the ON position. -Verify that the oven is plug into an electric source. -Verify the fuses in the electric box located on the oven's roof. (p.27)
The oven's shelves won't turn after having pressed the shelves rotation button.	The electrical circuit contacts for the shelves rotation have been cut.	-Verify that the bottom left access door is well positioned -Verify that the shelves rotation motor's base hasn't lifted and that it's not engaging the security dispositive. -The loading door must be closed to permit shelves rotation.(Québec) -Push the stop rotation button to reset the security line. - Verify the fuses in the electric box located on the oven's roof. (p.27)
The burner's ventilator isn't starting after having pushed the burner's start button.	The ventilator isn't receiving the start signal.	-Verify that the hood vacuum is working. - Verify the fuses, in the electric box located on the oven's roof. (p.27)
The burner's ventilator is working but the burner isn't lighting after a 30 second purge cycle.	The gas line may be cut.	-Verify that the gas valve on your gas line is in the open position. -Verify that the gas pressure is between 5 and 14 inches of water column.
	The Igniter isn't functioning correctly	- Verify the fuses in the electric box, located on the oven's roof. (p.27) -Verify that the burner is clean. Residue can block the gas at the igniter. -Change the igniter kit.
The burner lights but extinguishes shortly after.	The flame detector is malfunctioning.	-Make sure that the flame detector's rod isn't touching any corposants. -Verify That the flame detector is located at 1/4" over the burner. -Verify that no residue harms the flame detector. -Clean the flame detector's rod with a steel wool pad. -Change the flame detector
The oven's alarm is sounding for 2 seconds every 3 minutes.	The cooling fan for the control panel is malfunctioning.	-Change the fan.
The burner goes out when it reaches the set temperature.	The low fire parameters adjustments are inadequate.	Communicate with Picard Ovens Customer Service department to schedule a readjustment of the burner's parameters.

Verification list		
Client:		Dealer:
Installation date:		
Model:		
Serial Number:		Circle one:
Gas connections already installed on site	Yes	No
Chimney connections already installed	Yes	No
Verify all buttons of control panel	Yes	No
Verify amperage: RE8-16 = 9A RE8-24 = 9 A RE8-32=12A	Yes	No
Verify shelf rotation, forward and backwards	Yes	No
Verify ventilator motor rotation; This must turn clock wise.	Yes	No
Verify the connectivity of the wires at the terminal strips and contacts	Yes	No
Verify the door limit switch	Yes	No
Verify sprockets alignment and that the shelves are level	Yes	No
Verify inlet gas pressure when the oven is off: Pressure must be 5 – 14 W.C.	Yes	No
Note the gas line pressure:		
Verify inlet gas pressure when the oven is on high fire and all others equipment on the same pressure regulator are in operation. Pressure must be 5 – 14 W.C.	Yes	No
Note the gas line pressure:		
Verify the distributor pressure: 0" W.C. when the burner is lit on low fire.	Yes	No
Note the distributor pressure:		
Verify that the ventilation is installed correctly	Yes	No
Verify air pressure in the system: 16 = 600 CFM 24 = 800 CFM 32 = 1000 CFM	Yes	No
Verify that the chimney ventilator is installed.	Yes	No
Verify the pressure and the pressure switch	Yes	No
Verify that the burner working well at 400°F and maintain it during 1 hour. (Verify high and low fire)	Yes	No
Verify that the burner work well at the customer baking temperature.	Yes	No
Verify that there isn't negative pressure while all venting systems in the building are in operation.	Yes	No
Verify that the baking timer functions correctly	Yes	No
Verify the water flow (ml/impulsion) (Steam Option) 16 = 400 24 = 500 32 = 2 x 400	Yes	No
Verify the shelves and the client's moulds	Yes	No
Verify that the manhole is screwed closed	Yes	No
Verify the belt tension and the chain spring tension (compressed to 4 3/8")	Yes	No
Owner Instructed:		
Understand how to use the oven in a proper and secure fashion.	Yes	No
Understand how the digital control panel works.	Yes	No
Understands maintenance	Yes	No
Understand who to contact for service.	Yes	No
Notes:		
Customer's name (print):	Signature:	
Installer's name (print):	Signature:	

ELECTRICAL DIAGRAMS

Model/ Modèle: RE-4-8, RE-4-12, RE-8-16, RE-8-24 & SF-4-8, SF-4-12, SF-8-16, SF-8-24

208-240V/1PH/50-60Hz/9A

LEGEND / LÉGENDE

BUZ	= BUZZER / SONNETTE
C	= CONTACTOR / CONTACTEUR
F	= FUSE / FUSIBLE
H2O	= SELENOID VALVE / VALVE SÉLÉNOÏDE
H.L.	= HIGHLIMIT / HAUTE LIMITE
L.S.	= LIMIT SWITCH / INTERRUPTEUR DE FIN COURSE
M	= MOTOR / MOTEUR
P.S.	= PRESSURE SWITCH / INTERRUPTEUR DE PRESSION
TR	= TRANSFO

ELECTRONIC CARD DIP SWITCH SET UP / AJUSTEMENT DES MINI INTERRUPTEURS DE LA CARTE DE CONTRÔLE ÉLECTRONIQUE

- 1(HIGHFIRE1) -> ALWAYS ON / TOUJOURS ON
- 2(HIGHFIRE2) -> ALWAYS ON / TOUJOURS ON
- 3(TYPE FOUR) -> REV & SF = OFF MODULUX = ON
- 4(ELEC/GAZ) -> ELECTRICAL = OFF GAZ = ON
- 5(LOWFIRE1) -> OFF = 15% ON = 17% OFF = 20% ON = 22%
- 6(LOWFIRE2) -> OFF = 15% ON = 17% OFF = 20% ON = 22%
- 7(CONFIG5) -> STEAM = OFF / NO-STEAM = ON
- 8(CONFIG6) -> NO USED / NON UTILISÉ

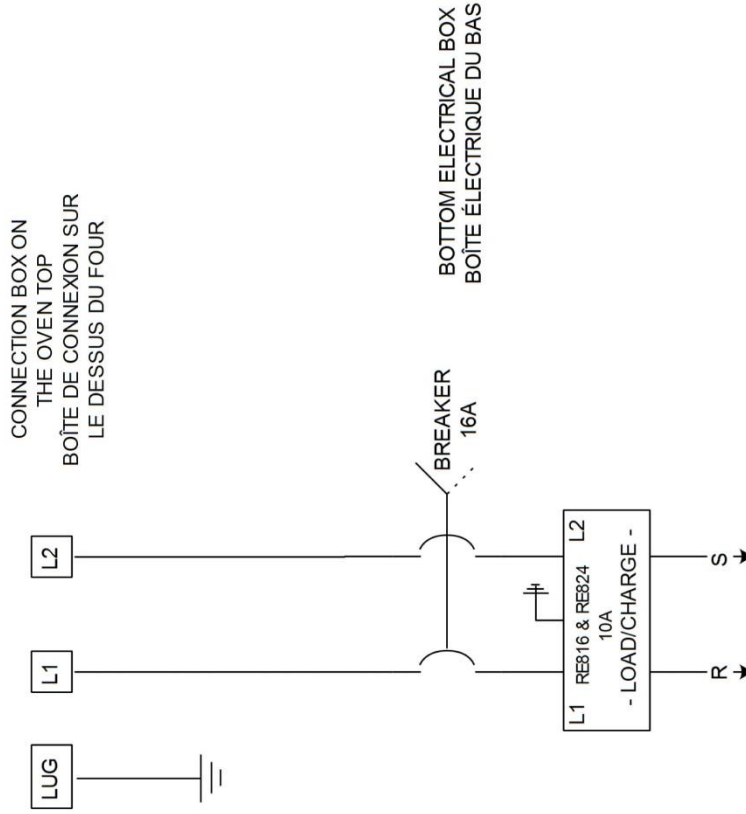

PICARD

ELECTRICAL DIAGRAM DIAGRAMME ÉLECTRIQUE

CONNECTION BOX / BOÎTE DE CONNEXION

RE800600 R06

23/09/2013

PAGE 1 OF 4

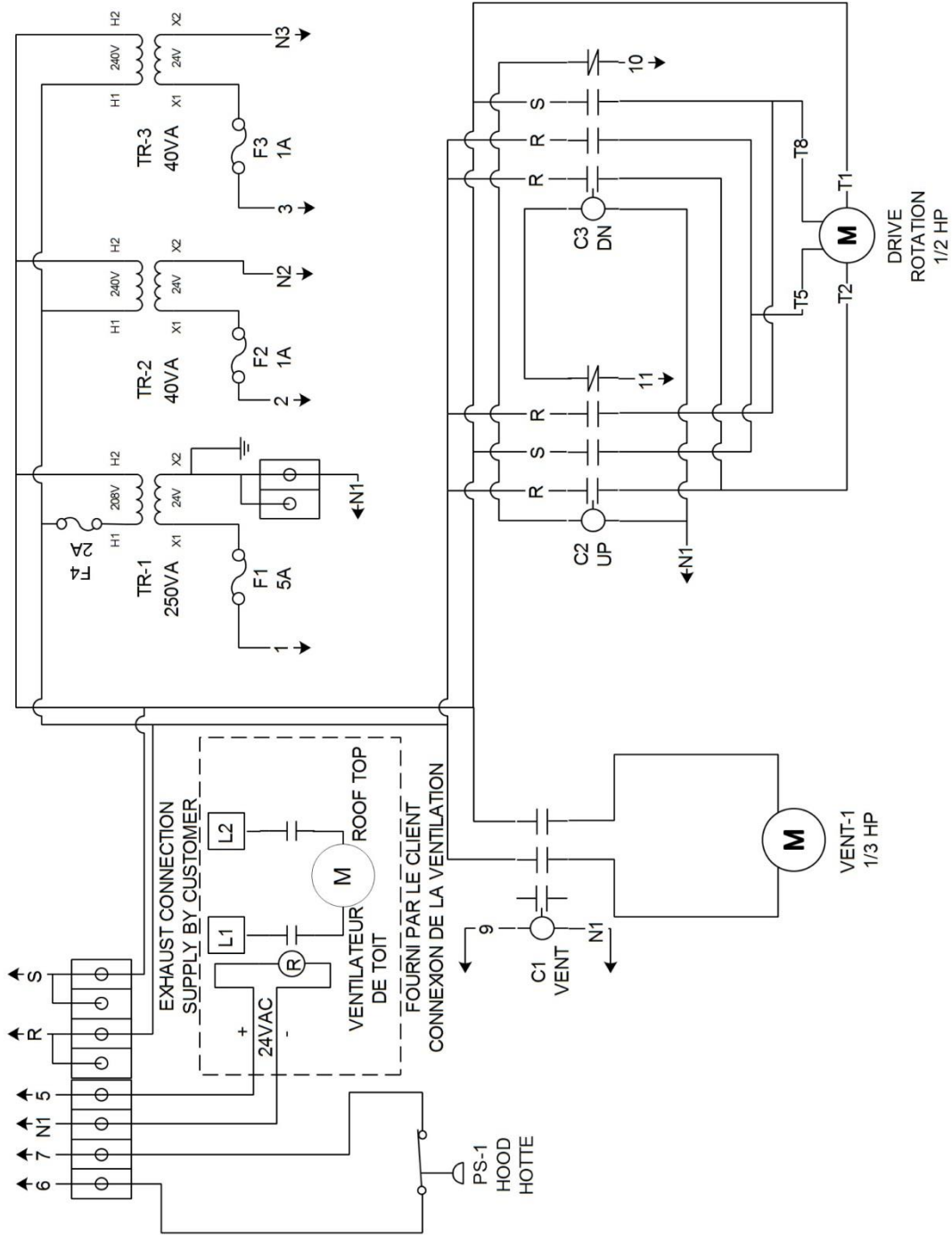

TOP ELECTRICAL BOX/ BOÎTE ÉLECTRIQUE DU DESSUS
 RE800600 R06
 23/09/2013
 PAGE 2 OF 4

ELECTRICAL DIAGRAM DIAGRAMME ÉLECTRIQUE



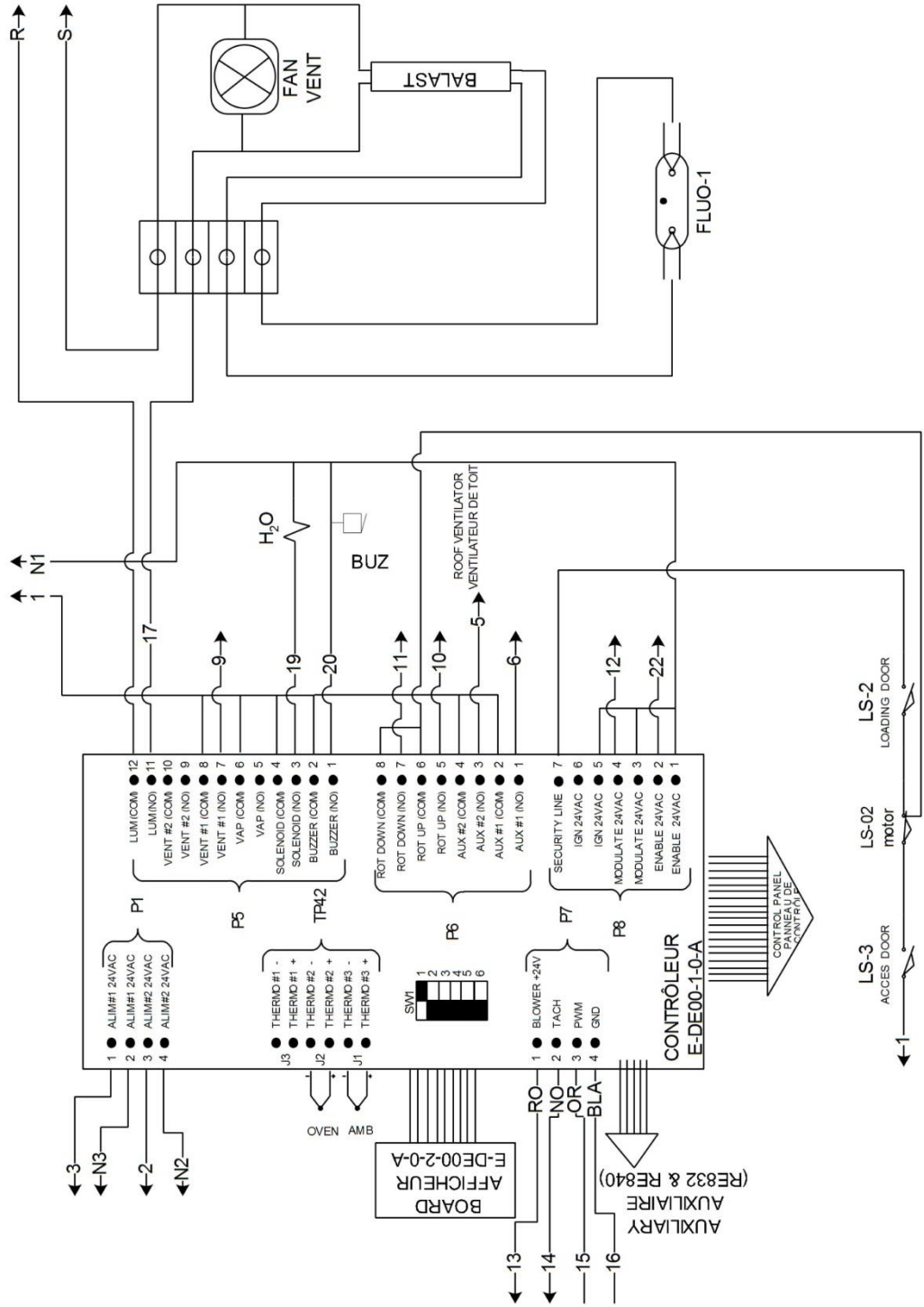

**ELECTRICAL DIAGRAM
 DIAGRAMME ÉLECTRIQUE**



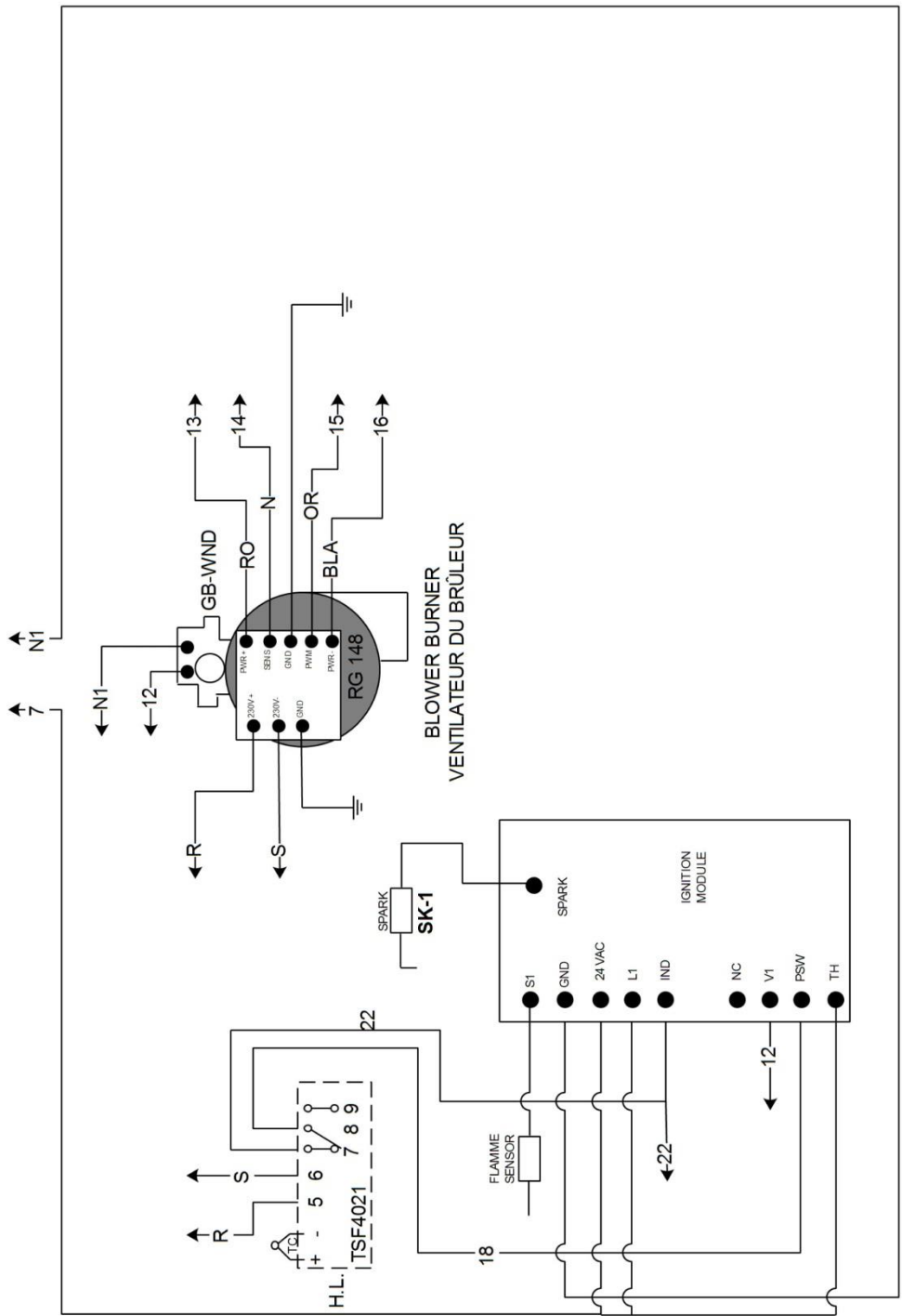

BURNER CONTROL/ CONTRÔLE DU BRÛLEUR

RE800600 R06

23/09/2013

PAGE 4 OF 4

ELECTRICAL DIAGRAM DIAGRAMME ÉLECTRIQUE





USA & Canada Sales Conditions and Limited Warranty

Picard Ovens, inc. warrants its equipment to be free from defect in material and factory workmanship under normal use for (1) one year from the date of the original Installation at the end client location to the original client. All warranty service must be pre-approved by Picard Ovens and have service authorization number prior to the execution of any services. Please contact our service department at 1 819-758-1883 or toll free at 1 800-668-1883. Our business hours are 8 a.m. to 5 p.m. Monday through Friday, Eastern time zone. If calling during non business hours, follow the recorded instructions for emergency service and someone will promptly contact you.

Client Responsibilities:

All necessary utilities must be installed to code by a licensed contractor and ready at start up. The client must inspect the equipment and crates at their delivery. Damage during transportation must be reported directly to the transportation company and to Picard Ovens. When installation of Picard equipment is made by an authorized dealer or any other person than one of Picard' employees, even in the presence of a Picard supervisor, the dealer or person installing shall be the only person responsible of any faulty installation of the equipment, no warranty being given by Picard on an installation performed by any person other than one of Picard's own employees. No labor warranty applies in such cases.

All Installations must be made by authorized service technicians and in accordance to the instructions furnished with the unit. The client must supply proof of the installation and the initial startup by filling out the forms furnished at the back of the owners users guide, dually signed by both the client and the service technician as witness that all required steps and verifications were successfully carried out and the installation is acceptable to the client. The form may be faxed or mailed to Picard Ovens at the coordinates found at the bottom of the page.

Proper maintenance procedures are found in the operators guide.

Precisions and limitations of liability:

This warranty is conditioned upon the following terms:

- The successful registration of the installation and start up forms.
- Terms of payment have been met.
- The equipment has not been accidentally or intentionally damaged, altered, misused or abused.
- Warranty coverage is at the sole discretion and is the exclusive right of Picard Ovens.
- Warranty replacement parts will be sent out under the authority of Picard Ovens, prepaid freight, expedited in the most rapid manner possible. It is the responsibility of the client to return all defective parts to the factory prepaid for proper warranty credit to be reimbursed.

In the event of warranty claim or otherwise, the sole obligation of Picard Ovens shall be to repair and / or to replace equipment or equipment components, at their own discretion. Such repair or replacement shall be at the expense of Picard Ovens with the exception of travel over 160 miles or two hours, overtime and holiday charges which shall be at the clients expense. Any repairs or replacement of equipment or its parts, under this warranty does not constitute an extension of the original warranty for any period. Parts to be replaced under this warranty will be repaired or replaced with new or functionally operative parts at the option of Picard Ovens.

Picard Ovens liability on any claim of any kind, including claims based on warranty, expressed or implied, contract, negligence, strict liability or any other theories shall be solely and exclusively the repair or replacement of the product as stated herein, and such liability shall not include, and purchaser specifically renounces any rights to recover, special, incidental, consequential or other damages of any kind whatsoever, including, but not limited to, injuries to persons or damage to property, loss of profits or anticipated profits, or loss of use of the product.

Damages are limited to the original purchase price.

Warranty labor charges will be calculated and paid using reasonable normal business hours and rates. This is to say Picard will pay 8 hours labor at a regular (Monday through Friday 8a.m. to 5 p.m.) hourly rate and within a 160 miles distance. Any overtime or excess travel charges will be the client's responsibility.

2013 Picard warranty_v1.01

Picard Ovens, Inc.
1325 Notre-Dame Est
Victoriaville, Qc. G6P 4B8
www.picardovens.com
info@picardovens.com

July 15, 2013



USA & Canada Sales Conditions and Limited Warranty

Exclusions:

Any damage incurred during transportation.

Use of any high pressure cleaning equipment will void this warranty.

Normal cleaning and maintenance functions: including lubrication or greasing.

Parts that would normally wear or need replacement under normal use (example: light bulbs, fuses, thermo-couples, belts and filters).

In the event that:

There is failure or malfunction of the equipment or any of its components caused by abnormal or improper use or the failure is otherwise not attributable to a material or manufacture defect.

Any failure caused by improper use, including but not limited to improper shelf loading.

The equipment has been altered from its original factory condition.

The rating plate has been removed, altered or obliterated.

The equipment has been improperly maintained, proper maintenance is the responsibility of the client.

Any parts that become defective because of utility services (power surges, high or low voltages, high or low gas pressure of volume, contaminated fuel or improper utility connections).

This warranty shall not apply if the equipment or any part is damaged as a result of accident, casualty, alteration, misuse, abuse, improper cleaning, improper installation, improper operation (including improper tray loading resulting in shelf jams, natural or manmade disasters). In no event shall Picard Ovens be held liable for direct, incidental or consequential damages arising out of or resulting from the operation of this equipment.

Picard assumes no liability for any contingent or consequential damages incurred by the client, including but not limited to down time, loss of business, damage or product loss.

In the event that the client denies access to an authorized technician (whom has been scheduled to make a service call) upon their arrival, releases Picard Ovens from of any and all warranted obligations and all expenses incurred are the sole responsibility of the client.

Note: Oven facades, windows, light bulbs, granite or baking stones are not covered under this warranty.

In case of any litigation or claim whatsoever regarding this Limited Warranty, the only competent courts shall be the ones of the judicial district of Arthabasca, province of Quebec, Canada. This Limited Warranty and all sales agreements for the equipment shall be construed, interpreted and executed in accordance with the laws in force in the province of Quebec, Canada.

Handling claims:

As soon as a defect is discovered, Picard Ovens must be notified. Our service manager will arrange for an authorized service agent to make the necessary repairs.

Call or email:

Telephone: 819-758-1883

Toll Free: 800-668-1883

Fax: 819-758-1465

Email: info@picardovens.com

A P P N E D I X