



**IMPORTANT FOR FUTURE REFERENCE**

PLEASE COMPLETE THIS INFORMATION AND RETAIN THIS MANUAL FOR THE LIFE OF THE EQUIPMENT.

MODEL #: \_\_\_\_\_

SERIAL #: \_\_\_\_\_

DATE PURCHASED: \_\_\_\_\_

**ENGLISH**

**Installation & Operation Manual**

**REDUCED OIL VOLUME  
FRYING SYSTEM**

Covering Models

**SELV14, SELV14T, SELV184**



## TO THE PURCHASER, OWNER AND STORE MANAGER

Please review these warning prior to posting them in a prominent location for reference

### WARNING

DO NOT store or use gasoline or other flammable vapors and liquids in the vicinity of this or any other appliance.

### WARNING

Improper installation, alteration, service or maintenance can cause property damage, injury or death. Read the installation, operating and maintenance instructions thoroughly before installing or servicing this appliance.

### WARNING

Installation, maintenance and repairs should be performed by a Pitco Authorized Service and Parts (ASAP) company technician or other qualified personnel. Installation, maintenance or repairs by unauthorized and unqualified personnel will void the warranty.

### WARNING

Installation and all connections must be made according to national and local regulations and codes in force.

### WARNING

A country approved all pole circuit breaker with a minimum open contact gap of 3mm must be used for proper installation. (CE countries)

### WARNING

During the warranty period if a customer elects to use a non-original part or modifies an original part purchased from Pitco and/or its Authorized Service and Parts (ASAP) companies, this warranty will be void. In addition, Pitco and its affiliates will not be liable for any claims, damages or expenses incurred by the customer which arises directly or indirectly, in whole or in part, due to the installation of any modified part and/or received from an unauthorized service center.

### WARNING

This appliance, when installed, must be electrically grounded in accordance with local codes, or in the absence of local codes, with the National Electrical Code, ANSI/NFPA 70, or the Canadian Electrical Code, CSA C22.2, as applicable.

### WARNING

Adequate means must be provided to LIMIT the movement of this appliance without depending on the electrical cord connection. Single appliances equipped with legs must be stabilized by installing anchor straps. All appliances equipped with casters must be stabilized by installing restraining chains.

### WARNING

DO NOT alter or remove structural material on the appliance to accommodate placement under a ventilation hood.

### WARNING

This appliance is intended for commercial/professional use only and should be operated by fully trained and qualified personnel. It is not intended for continuous mass production of food.

### WARNING

This appliance is intended for indoor use only.

### WARNING

If the power supply cord is damaged, it must be replaced by a Pitco Authorized Service and Parts (ASAP) company technician, or a similarly qualified person in order to avoid a hazard. In Europe, supply cords must be oil resistant, sheathed flexible cable not lighter than ordinary polychloroprene or other equivalent synthetic elastomer-sheathed cord (Code designation 60245 IEC 57).

### WARNING

The power supply must be disconnected before servicing, maintaining or cleaning this appliance.

### WARNING

The appliance is NOT water jet stream approved. DO NOT clean the appliance with a water jet or steam cleaner.

### WARNING

DO NOT attempt to move this appliance or transfer hot liquids from one container to another when the unit is at operating temperature or filled with hot liquids. Serious personal injury could result if skin comes in to contact with the hot surfaces or liquids.

### WARNING

DO NOT sit or stand on this appliance. The appliance's front panel, tank, splash back, tank cover, work shelf, drain board is not a step. Serious injury could result from slipping, falling or contact with hot liquids.

### WARNING

NEVER use the appliance as a step for cleaning or accessing the ventilation hood. Serious injury could result from slips, trips or from contacting hot liquids.

### WARNING

Potential fire danger exists if the cooking oil level is below the minimum indicated level. The cooking oil level should NOT be allowed to fall below the minimum indicated level line at any time. The use of old cooking oil can be dangerous as it will have a reduced flash point and be more prone to foaming over.

### WARNING

The contents of the crumb catch and/or filter pan of any filter system must be emptied into a fireproof container at the end of each day. Some food particles can spontaneously combust if left soaking in certain types of oil or shortening.

### WARNING

Completely shut the appliance down when shortening/oil is being drained from the appliance. This will prevent the appliance from heating up during the draining and filling process. Serious injury can occur.

### WARNING

DO NOT operate appliance unless all panels and access covers are attached correctly.

### WARNING

It is recommended that this appliance be inspected by a qualified service technician for proper performance and operation on a yearly basis.

## TABLE OF CONTENTS

<b>1</b>	<b><u>THEORY OF OPERATION</u></b>	<b>5</b>
<b>2</b>	<b><u>INSTALLATION</u></b>	<b>6</b>
2.1	CHECKING AND UNPACKING YOUR NEW APPLIANCE	6
2.2	GENERAL INSTALLATION REQUIREMENTS	7
2.3	INSTALLATION CLEARANCES	7
2.4	LEVELING THE FRYER- LEGS/CASTERS	8
2.5	ELECTRICAL CONNECTIONS	9
2.6	FIXED WIRING and RESTRAINT CABLE	10
2.7	VENTILATION AND FIRE SAFETY SYSTEMS	11
2.8	INSPECTION	11
2.9	INITIAL CLEANING	12
<b>3</b>	<b><u>OPERATION</u></b>	<b>13</b>
3.1	OPERATIONAL FEATURES	13
3.2	FILLING THE FRY POT	15
3.3	APPLIANCE START UP	16
3.4	APPLIANCE SHUTDOWN	16
<b>4</b>	<b><u>OIL MANAGEMENT</u></b>	<b>17</b>
4.1	COOKING	17
4.3	BASKET LIFT OPERATION	17
4.4	FRESH OIL TOP OFF FUNCTION	17
4.5	AUTOMATIC OIL TOP OFF SYSTEM (OPTION)	17
4.6	QUICK STRAIN FILTERING	18
	4.6.1. NON-AUTO Filter models	18
	4.6.2 AUTO FILTER MODELS	18
<b>5</b>	<b><u>PREVENTATIVE MAINTENANCE</u></b>	<b>19</b>
5.1	DAILY PREVENTATIVE MAINTENANCE	19
	5.1.1 DAILY FILTERING	19
	5.1.2 FLUSH HOSE OPERATION (if equipped)	20
	5.1.3 REPLACING THE FILTER MEDIA (if equipped)	20
	5.1.4 CLEANING THE CABINET	21
	5.1.5 FILTER CLEANING (If Equipped)	21
	5.1.6 APPLIANCE INSPECTION	21
5.2.	WEEKLY PREVENTATIVE MAINTENANCE	21

<b>5</b>	<b><u>PREVENTATIVE MAINTENANCE</u> (continued)</b>	
5.3	MONTHLY PREVENTATIVE MAINTENANCE	22
5.3.1	BOIL OUT PROCEDURE	22
5.3.2	TEMPERATURE CHECK	22
5.4	ANNUAL/PERIODIC PREVENTATIVE MAINTENANCE AND INSPECTION	23
5.4.1	SAFETY EVALUATION	23
5.4.2	MECHANICAL INSPECTION	23
5.4.3	TEMPERATURE CONTROL SYSTEM	23
5.4.4	FILTER SYSTEM (IF EQUIPPED)	23
5.4.5	HEATING ELEMENT	23
5.4.6	CONTROL BOX & ELECTRICAL COMPONENTS	23
<b>6</b>	<b><u>TROUBLESHOOTING</u></b>	<b>24</b>
6.1	POWER FAILURE	24
6.2	HIGH TEMPERATURE LIMIT	24
6.3	DRAIN VALVE INTERLOCK	24
6.4	FRYER TROUBLESHOOTING CHART	25
6.5	FILTER TROUBLESHOOTING CHART	26
6.6	CONTROLLER DISPLAYS	27

# 1 THEORY OF OPERATION

The Pitco Reduced Oil Volume fryer works very similarly to the Pitco standard electric fryer. Other than rotating elements (for cleaning), the appliance functions nearly the same. The Low Oil Volume Fryer has a reduced cold zone to significantly reduce oil usage and extend oil life. This smaller zone may require more frequent filtering depending on the product being fried.

Upon turning the fryer on, the high limit closes the (side on) safety contactor which stays closed until the fryer is turned off. If the oil temperature exceeds 450 °F, the high limit opens and prevents further operation until the cooking oil has reached a safe cooking temperature. This places a minimum duty cycle on the safety (side on) contactor to insure its proper operation when needed. The “heat demand” contactor opens and closes on demand from the primary control to maintain the desired cooking temperature. When the “heat demand” contactor closes, it energizes the heating elements in the fry pot. Near the fryer heating elements, the temperature and high limit sensor probes can be found. The temperature probe provides a signal to the primary control, sensing the oil temperature in the fry pot.

The fryer is equipped with a manual “ADD OIL” function that can transfer fresh oil from a JIB (Jug in Box) located under the fryer or a bulk oil management system. The operator can use the manual “ADD OIL” button as needed to replenish any oil consumed in the cooking process. It is recommended that oil only be added when the fry pot is at the desired temperature, and that the “ADD OIL” function not be used to fill an empty fry pot from the JIB.

Optional Automatic Top Off: If equipped, the fryer (only when operating at desired temperature) senses the oil level and replenishes consumed oil only between cook cycles. There are no programming options for the operator or service technician, the control functions like any other Pitco electric fryer computer control. The “ADD OIL” function (described above) is present with models equipped with Auto Top Off.

## 2 INSTALLATION

### 2.1 CHECKING AND UNPACKING YOUR NEW APPLIANCE

Your new Pitco appliance has been carefully packed into one crate. Every effort has been made to ensure that it is delivered to you in perfect condition. Pitco does not assume responsibility for damage or loss incurred in transit.

1. Upon Delivery, inspect for visible shipping damage in the presence of the trucking operator. If something appears damaged, file a claim for damages regardless of extent.
2. Unpack and inspect unit for damage. Contact the shipper within 15 days and file a concealed damage claim; the shipper is only responsible for concealed damage for 15 days after delivery.
3. Remove the unit from the shipping pallet:  
 Remove the filter pan, and JIB pan from unit before attempting to dismount the unit from the shipping base.
4. Do not allow the full weight of the unit to rest on the legs or caster when removing the appliance from the shipping pallet. The casters can be bent or damaged if too much weight or force is applied to them from improper handling.
5. Check the packing list enclosed with your appliance to ensure that you have received all the parts to the appliance. Refer to figure 1 for accessory identification. If you are missing any parts, contact the dealer from whom the appliance was purchased.
6. Using the front cover of this manual, record the following for warranty service or future reference: 1. Your Pitco model number. 2. Fryer serial numbers (Found on the inner door of each fryer). 3. The date purchased from your dealer invoice.

Once you have completed the above, the appliance is ready to be installed.

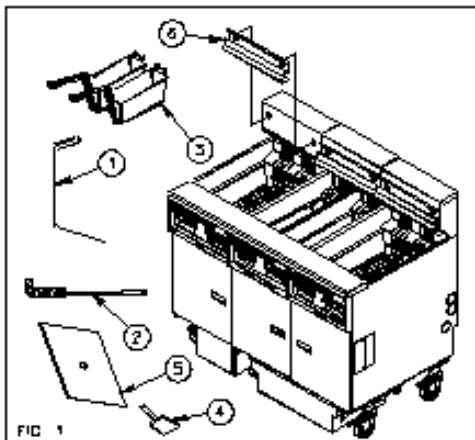

#### FRYER ACCESSORIES

Item #	Part #	Description	Qty
1	A3301001	Drain Clean Out Rod	1
2	PP10056	Frypot Cleaning Brush	1
3	P6072145	14" Size Fry Baskets	2
4	B6681201	Filter Sediment Scoop	1
5	A6667104	Filter Media Starter Pack	1
6	A1108002	Removable Basket Hanger	1*

\* Quantity one per fry pot.

## CAUTION

It is important that you read and understand this manual before installing, operating or servicing this appliance. Be sure to retain this manual for future reference.

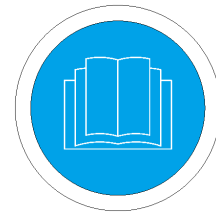

## 2.2 GENERAL INSTALLATION REQUIREMENTS

The installation of this appliance must be performed by an authorized service professional. A qualified professional will ensure that the installation is safe and meets local or national building, electrical, and fire codes.

Where conflict exists between instructions in this manual, and local, or national codes or regulations, installation and operation shall comply with the codes or regulations of the locale in which the appliance is installed.

## 2.3 INSTALLATION CLEARANCES

The clearances shown below are for combustible and non-combustible installations and will allow for safe and proper operation of your appliance

	Combustible Construction Inches (Centimeters)	Non-Combustible Construction Inches (Centimeters)
Back	6.0 (15.24)	0.0 (0.0)
Sides	6.0 (15.24)	0.0 (0.0)
Aisle	35.0 (88.9)	35.0 (88.9)

## WARNING

**DO NOT** obstruct the flow of ventilation air openings around the appliance. Adequate clearance around the appliance is necessary for servicing and proper component ventilation. Ensure that you meet the minimum clearance requirements specified in this manual.

## WARNING

**DO NOT** install this appliance next to a water cooker, or use in any way in which water can come in contact with the hot oil. Splash over of water into hot oil may result in a steam eruption, potentially causing hot oil to be ejected from the fryer, and creating a burn hazard.

## 2 INSTALLATION

### 2.4 LEVELING THE FRYER- LEGS/CASTERS

#### CAUTION

To prevent equipment damage and/or personal injury, do not tilt the appliance onto any two of its casters or legs, or pull the appliance by the splash back.

#### WARNING

This appliance must be installed with the legs or casters provided by the manufacturer.

#### WARNING

DO NOT perform leveling procedure when appliance is in operation or full of hot liquids. Serious injury could result.

When you receive your appliance, it is completely assembled with legs or optional casters. This appliance must be installed with legs or casters; it cannot be curb mounted, or sealed to a base. Curb mounting will seriously inhibit this appliance's ability to effect proper component ventilation. The supplied legs or casters provide the necessary height to meet sanitation requirements and assure adequate air supply for electrical component ventilation. To level the fryer, use the following procedure.

Required tools: A large pair of water pump pliers, a medium sized flat blade screwdriver and a 12" (30.5 cm) long level.

- 1 Position appliance in final installed location.
- 2 Apply level across front, and then the left and right side of unit, determine lowest point and distance to level.
- 3 Add the distance determined in step 2 to caster or leg on the lowest corner of appliance.
  - a. Swivel casters- loosen 2 set screws (A)
  - b. Legs and swivel casters-. Adjust the height of the leg / caster by turning adjustment collar/ foot (B) with water pump pliers until desired change in height is achieved.
  - c. Swivel casters only: Retighten set screws (A).
  - d. Fixed casters- Adjust height by moving wheel and axle to alternate holes (D) in wheel bracket as needed. Refer to "FIXED" type caster as shown below.
- 4 Adjust remaining casters or legs as needed to insure the appliance is supported evenly at each caster/leg contact point.

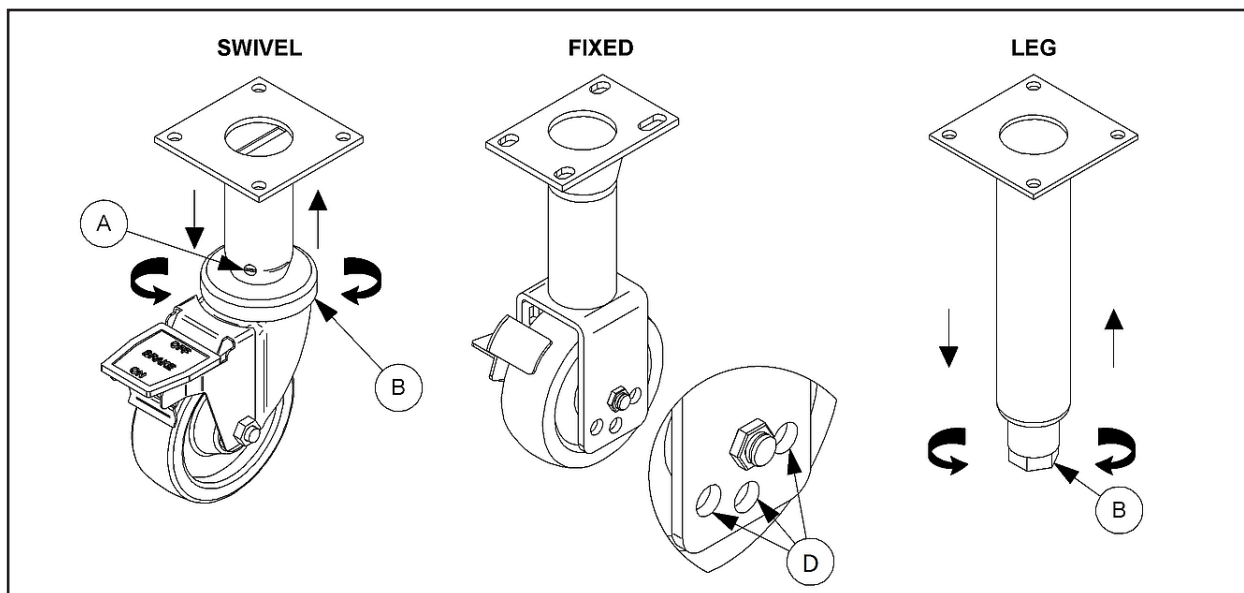

# INSTALLATION

## 2.5 ELECTRICAL CONNECTIONS

It is advised that this appliance be connected to a power supply that is controlled by the ventilation system. This will prevent the appliance from being operated without the ventilation hood on. If your appliance is single phase, it requires a hardwired, flexible conduit electrical connection, using conductors sized appropriately for the power requirements listed below. Hardwired units require installation of a restraint device mounted to a safe and substantial element of the building's structure.

Electrical Requirements		Nominal Amps Per Line (50/60 Hz)															
		Single Phase (2 Wire and Ground)						3 Phase (3 Wire and Ground)						3 Phase Wye (4 Wire and Ground)			
Model	kW	200V	208V	220V	230V	240V	480V	200V	208V	220V	230V	240V	480V	346/200V	380/220V	400/230V	415/240V
SELV14 SELV14T	14	65	67	65	61	58	29	37	39	37	35	34	17	21	21	20	20
SELV14 SELV14T SELV184	17	79	82	78	74	71	36	46	48	45	43	41	21	27	26	25	20

\* Measurements include both tanks. 1. Each fryer requires its own separate power cord. 2. 200V units will operate at 92% of rated power. 3. Power supply for Basket Lifts and Filter Motor is wired to the fryer's high voltage line terminal block, except for 480V, which requires a separate single phase power service for the Filter Motor and Basket Lifts (if equipped) rated at 115V, 8.0 A for North America or 220-240V, 4A for Export to be installed.

### CAUTION

Connecting the appliance to the wrong power supply may damage the appliance and void the warranty.

### WARNING

This appliance must be connected to a power supply having the same voltage and phase as specified on the data plate located on the inside of the appliance door. **DO NOT** connect the appliance to an electrical supply other than that indicated on the data plate. Electrical connection should be performed by a qualified electrician.

### WARNING

The electrical connection used by this appliance must comply with local codes. If there are no local codes that apply, refer to the National Electrical Code (NEC), ANSI/NFPA 70 for installation in the US. In Canada, refer to CSA Standard C22.2 and local codes. In all other cases, refer to local and national codes and regulations.

The appliance must be grounded in accordance with local code, comply with the NEC and ANSI/NFPA No. 70 latest edition (for US and Canada). In all other cases, refer to local and national codes and regulations. To comply with EU requirements, European models are equipped with an equalization-bonding clamp. An equalization bonding lead must be connected to this clamp to provide sufficient protection against potential difference. This clamp, located on the rear of the appliance, is marked with the following symbol.



### WARNING

A country approved all pole circuit breaker with a minimum open contact gap of 3mm must be used for proper installation. (CE countries)

### CAUTION

Leakage current of this appliance may exceed 10 mA. When permanently connected, a high integrity protective system employing an RCD rated at 30 mA must be used with this appliance.

### WARNING

This equipment must be installed so that the plug (if used) is accessible unless other means for disconnection from the power supply (e.g.: circuit breaker) is provided.

# INSTALLATION

## 2.6 FIXED WIRING and RESTRAINT CABLE

If your appliance was not equipped with an optional cord set and plug, fixed connection to the electrical power supply will be required. This must be performed by a licensed electrician. A licensed electrician will properly size the wiring and ensure that the installation meets all local or national codes and warnings in force when making field connections to mains.

### WARNING

If this appliance is permanently connected to fixed wiring, it must be connected by means of copper wires having a temperature rating of not less than 167°F (75°C), and have a local means of disconnection from all poles from the mains included in the fixed wiring in accordance with local codes.

### WARNING

All power connection wiring for this appliance must be made in accordance with the wiring diagrams(s) located on the appliance.

Fixed wiring connection procedure:

1. Remove the fryer entrance box cover, Figure 2.6.1.
2. Insert power cable/conduit through hole in fryer cabinet, Figure 2.6.2. Use care when routing power cable/conduit through the fryer to not interfere with actuator movement.
3. Referring to figure 2.6.3, Install cable strain relief in housing **cutout** (1). Attach power cable wires to terminal block (2) per connection diagram on fryer door.
4. Attach a movement restraint cable assembly to any fryer that is not connected with a cord and plug, Figure 2.6.4.

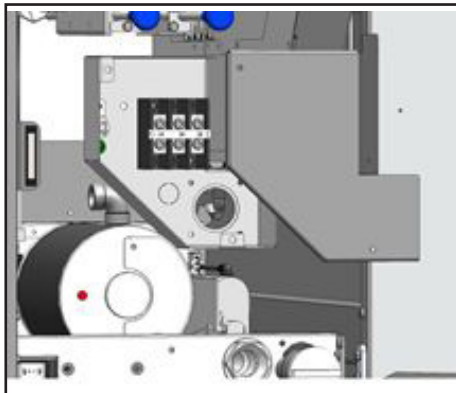

Figure 2.6.1 - (Drain line removed for clarity).

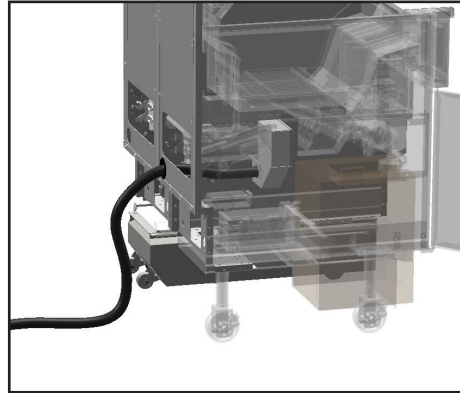

Figure 2.6.2 - Insert flexible conduit through cabinet as shown to prevent contact with moving parts.

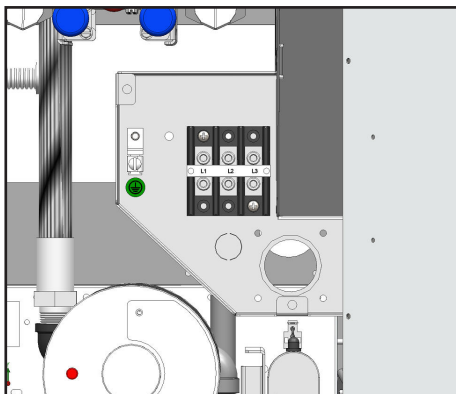

Figure 2.6.3 - Wire housing strain relief hole: 2" or 1.75" diameter.

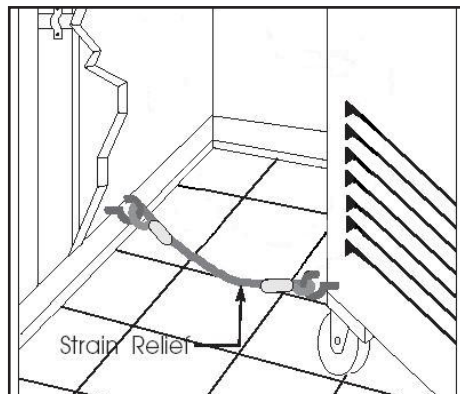

Figure 2.6.4 - Fryers on casters, and/or installed with flexible conduit must have a restraint cable installed between the fryer and substantial structural element to prevent strain on conduit.

2.7 VENTILATION AND FIRE SAFETY SYSTEMS

Your new appliance must have proper ventilation to function safely and properly. It is very important to install a fire safety system. Your ventilation system should be designed to allow for easy cleaning. Frequent cleaning and proper maintenance of the ventilation system and the appliance will reduce the chances of fire. Ventilation and fire safety systems must comply with local and national codes.

2.8 INSPECTION

Before you begin filling and operating the appliance, perform the following visual checks:

- √ After the appliance is in its permanent location, check to make sure it is level and stable. Any additional leveling that is necessary can be performed as previously described in “Leveling the Fryer”. (Refer to section 2.4)
- √ Ensure that high temperature limit probe(s), item 2 in figures 2.8.1 & 2.8.2 below are in place and secure as shown below. Ensure the temperature control probe(s) (item 1) is positioned properly as shown.
- √ Ensure the heating elements (3) are free to move up out of the frypot without hitting any structures or other items above the fryer.
- √ Review the installation portion of this manual and ensure that all steps have been followed and executed properly.

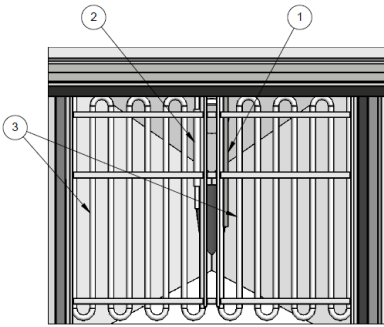

Figure 2.8.1 - Frypot view SELV14

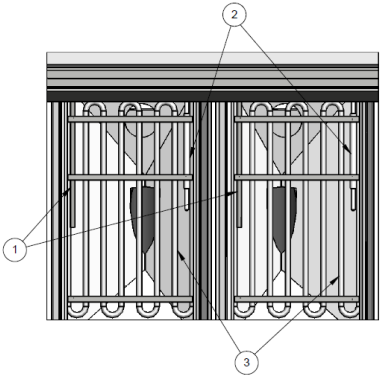

Figure 2.8.2 - Frypot view SELV14T

# INSTALLATION

## 2.9 INITIAL CLEANING

When your appliance is shipped, many of its parts are covered with a thin coat of oil for protection. Before the appliance is ready for cooking all transit material must be removed and the appliance must be cleaned. This will remove the oil coating and any foreign matter that may have accumulated during storage and shipment. Refer to the following procedure to clean the appliance.

### WARNING

**Wear protective gloves and clothing when cleaning and draining the appliance and when disposing of water. The water is extremely hot and can cause severe injuries.**

### CAUTION

**DO NOT leave the appliance unattended during cleaning. NEVER let the liquid level go below the oil level line.**

### NOTICE

**DO NOT run water through the filter return system. This will damage the pump and void your warranty.**

1. Read the "operation" section of this manual prior to filling or operating the appliance.
2. The following steps should be followed using a food grade cleaner.

### WARNING

**Use a commercial grade cleaner formulated to effectively clean and sanitize food contact surfaces. Read the directions and precautionary statements before use. Particular attention must be paid to the concentration of cleaner and the length of time the cleaner remains on the food contact surfaces.**

3. Following the cleaning directions in this manual to clean the tank interior and all other food contact surfaces.
4. When cleaning is complete, rinse the inside of the tank thoroughly with cool water. Continue to rinse the tank until the cleaner has been completely and thoroughly rinsed from the tank.
5. Using a clean dry cloth, wipe out all of the water in the fry tank.
6. Using a clean cloth and food grade cleaner, clean the bread and batter station and/or filter pan, if equipped.

If the appliance can't be adjusted to operate properly contact a qualified service person or contact the factory using the contact information on the back of this manual.

# 3 OPERATION

## 3.1 OPERATIONAL FEATURES

The figures below outline some of the key operational components of your appliance. Refer to the following sections of this manual to learn more about these and other features.

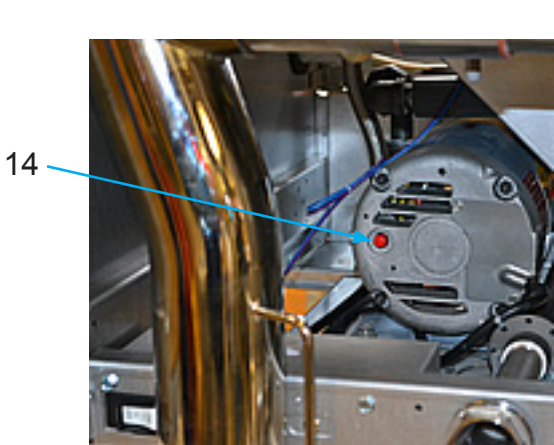
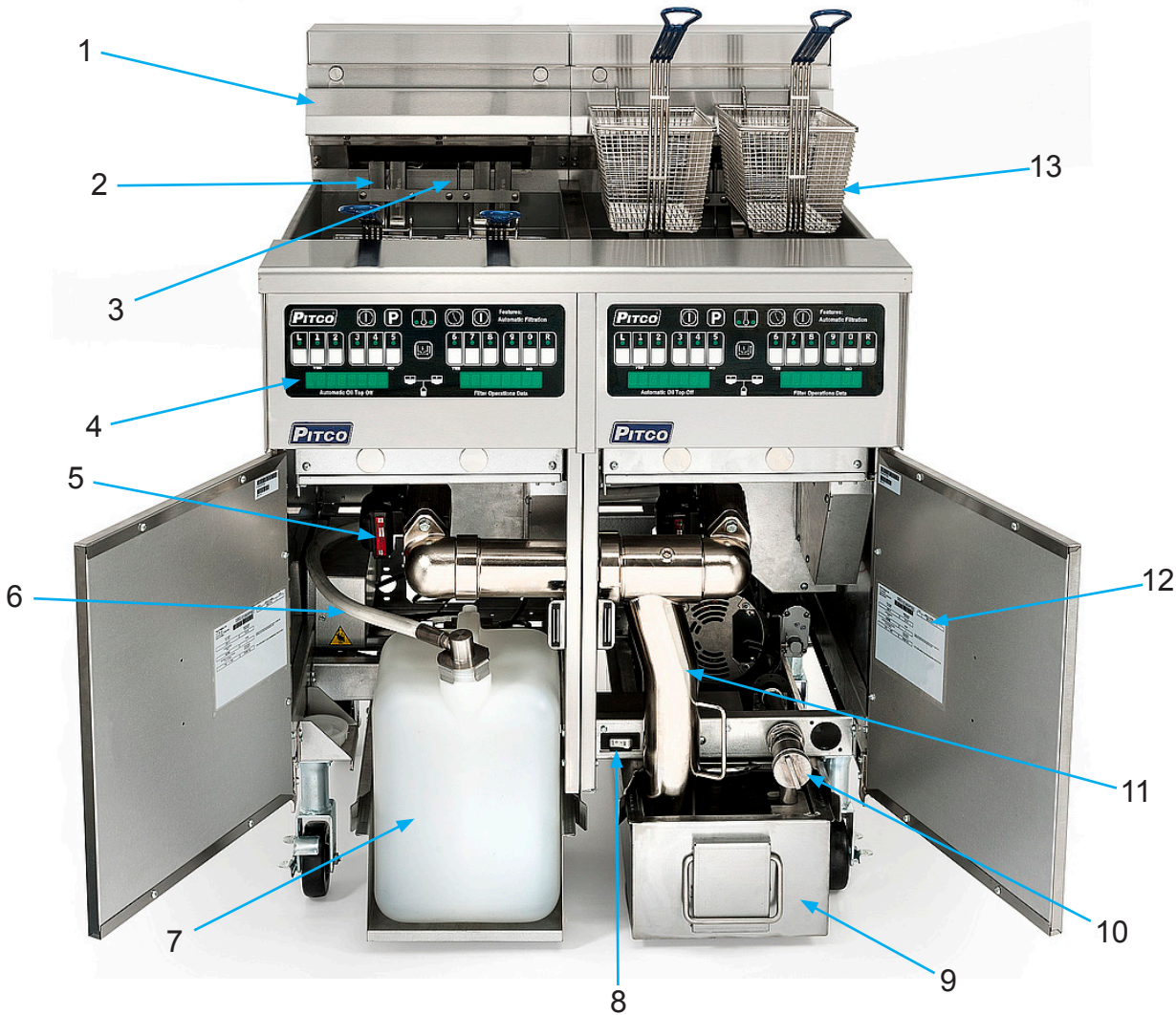

### 3 OPERATION

<u>ITEM #</u>	<u>DESCRIPTION</u>	<u>FUNCTION</u>
1	BASKET HANGER	Holds fry baskets while draining cooked product or between loads. Lifts off for easy cleaning.
2	HEATING ELEMENT	Heats cooking oil to desired temperature.
3	TEMPERATURE PROBE	Senses the oil temperature in the cook zone.
4	COOKING COMPUTER*	A programmable cooking computer that controls oil temperature and provides cook time tracking.
5	ELECTRIC DRAIN VALVE	On Automatic models only. Operators can use the cooking computer to open or close the fry tank drain valve.
6	OIL JUG CONNECTOR	Makes transfer of oil between the fry tank and the top off oil jug possible.
7	OIL TOP OFF JUG	Supplied by others, provides on board storage of fresh cooking oil for topping of fry tanks in between cooks.
8	FILTER PUMP CIRCUIT BREAKER	Protects pump motor from damage in the event of overcurrent.
9	FILTER PAN ASSEMBLY	Holds oil during frypot cleaning and filter operations. Contains filter pickup assembly.
10	FILTER PUMP STRAINER	Helps prevent debris from clogging the filter pump if filter paper rips or is poorly installed.
11	DRAIN OUTLET	Directs cooking oil into the filter pan when drain is opened. Swivels up to make cleaning easier. Caution! May be HOT!
12	DATA PLATE	Contains important model and operational information.
13	FRY BASKETS	Assorted sizes and configurations are available. Contact the Factory.
14	FILTER MOTOR THERMAL RESET BUTTON	Press to reset the filter motor. Caution! Read this manual before using this function.
15	OIL LEVEL STAMP	Shows the oil level required for normal use.

\* An operator's manual for your appliance's specific control type should be included with this manual. Refer to that manual prior to operating this appliance.

## 3.2 FILLING THE FRY POT

Refer to the following procedure to fill the cook tank prior to operation.

**CAUTION**  
**Solid shortening must not be used, or clogged pump lines, and pump damage are possible.**

### OIL AND COOK LOAD CAPACITIES

Fryer Model	TANK (OIL) CAPACITY* LBS (KG)	COOK LOAD CAPACITY** LBS (KG)
SELV14 (R,X)	30 (13.6)	1.5 (0.68)
SELV14T (R.X)	17 (6.8)	1.5 (0.68)
SELV184	43 (19.5)	2.5 (1.1)

\* Per Tank

\*\*Per Basket

It is recommended that a high-quality liquid frying oil be used. DO NOT use solid shortening. Use of solid shortening may result in clogged pump/filter lines or pump damage.

1. Verify that the tank interior is clean and free of any construction debris.
2. Rinse the tank and drain line with a small amount of clean cooking oil.
3. Ensure that the drain valve is closed.
4. Fill the tank with oil. You may fill the tank to slightly below the nominal level mark: the oil will expand slightly when it heats up, raising the level slightly.

**WARNING**  
**THE PUSH BUTTON TOP OFF SYSTEM IS NOT INTENDED TO FILL FRY POTS.**

**WARNING**  
**Replace oil/shortening that is smoking, or foams when cooking. Old, heavily used oil/shortenings have a reduced flash point and are prone to surge boiling. Cooking with old shortening may create dangerous conditions.**

**WARNING**  
**Do not overload the fry baskets, or allow the oil level to exceed the MAX line while cooking. Wet product, or too much oil in the frypot can lead to surge boiling, and over topping the frypot. Overtopping may create hazards such as burns or slippery floors.**

**CAUTION**  
**This appliance is NOT designed for cooking with water. Severe equipment damage will occur if a fryer is used as a water bath for rethermalizing foods. Damage of this type is not covered under the warranty.**

**WARNING**  
**Oil must completely cover the heating elements at all times while appliance is on.**

## OPERATION

### 3.3 APPLIANCE START UP

Refer to the following procedure to start the appliance prior to operation.

1. Ensure that the drain valve is closed.
2. Fill the cook tank with oil. (See section 2.9 "Filling the Cook Tank").
3. Press the  button to turn the controller on.
4. The appliance is now on and heating the oil in the cook tank.

#### WARNING

**NEVER** operate the appliance with an empty fry tank. It will void the warranty.

#### WARNING

Dry firing the elements could cause a fire or other unsafe situation. Dry fired elements are extremely hot, may damage the element and could void your warranty. Never allow a dry fired element to come into contact with cooking oil.

#### WARNING

Oil/shortening level should **NOT** be allowed to fall below the minimum indicated level line at any time. Dry firing of the elements may cause a fire, and can shorten element service life. Evidence of dry firing will void your warranty.

#### OIL TEMPERATURE

Keep the oil temperature in the fryer to a maximum of 190°C (374°F). Higher temperatures will cause rapid breakdown of the oil and give you no faster cooking. At 205°C (401°F) to 210°C (410°F) the life of the oil is only one third of its life at 190°C (374°F). In addition, increased decomposition causes the oil to smoke badly even if the temperature is lowered to 190°C (374°F) again. High temperatures give you no advantage, cost you money and increase the fire danger.

#### TEMPERATURE DELL'OLIO

Mantenere la temperatura dell'olio nella friggitrice fino a un massimo di 190°C. Temperature maggiori causano un rapido degrado dell'olio, senza tuttavia eseguire una cottura più rapida. Da 205°C a 210°C la durata dell'olio è inferiore di un terzo rispetto a quella a 190°C. Inoltre, l'accresciuta decomposizione comporta una forte emissione di fumo, anche se la temperatura viene riportata di nuovo a 190°C. Le alte temperature non prevedono vantaggi, sono antieconomiche e aumentano il rischio d'incendio.

#### ΘΕΡΜΟΚΡΑΣΙΑ ΛΑΔΙΟΥ

Διατηρείτε τη θερμοκρασία λαδιού στη φριτέζα μέχρι 190 βαθμούς Κελσίου. Υψηλότερες θερμοκρασίες θα αλλάξουν τη σύνθεση του λαδιού πολύ σύντομα και δεν ψήνεται γρηγορότερα. Η δυναμικότητα του λαδιού στους 205-210 βαθμούς Κελσίου είναι μόνο το ένα τρίτο της δυναμικότητάς του στους 190 βαθμούς Κελσίου. Επιπλέον η αυξημένη αποσύνθεση του λαδιού, σε θερμοκρασίες πάνω από 190 βαθμούς Κελσίου, κάνει το λάδι να καπνίζει άσχημα κι αν ακόμη κατεβάσετε τη θερμοκρασία κατόπιν πάλι στους 190 βαθμούς Κελσίου. Οι υψηλές θερμοκρασίες δε σας παρέχουν κανένα πλεονέκτημα, σας κοστίζει περισσότερα χρήματα και αυξάνουν τον κίνδυνο πυρκαγιάς.

### 3.4 APPLIANCE SHUTDOWN

Refer to the following procedure to shut down the appliance.

1. Press and hold the computer control  button to turn the controller OFF.

## 4 OIL MANAGEMENT

### 4.1. COOKING

To ensure the quality of the food you cook in this appliance, follow the preparation instructions from the food manufacturer. When the appliance is not in use, the oil should be cooled and covered to prevent contamination.

### 4.2 COOKING GUIDELINES

- Always follow the food manufacturer's directions concerning oil temperature and cook time.
- The lower the oil temperature, the longer the cook time and the greater the oil absorption into the food.
- Don't over fill baskets. Filling baskets more than half full by volume may result in foaming over the top of the fryer.
- Don't overload the fryer. The maximum rated load for the SELV14 and SELV14T is 1.5 pounds (.68 kg) per basket and 2.5 pounds (1.1 kg) for the SELV184. Over filling baskets can cause uneven cooking, yield soggy, greasy food product and result in oil foaming over the top of the fryer.
- Do not load the fry baskets over the frypot. Re moving the baskets from the fryer to load food reduces the need to filter.
- After removing the baskets from the fry pot, shake gently to remove excess oil.
- Never leave baskets containing cooked product over the fry pot. The heat from the hot oil will continue to cook the product.
- Oil/shortening quality can affect product quality. Keep salt and moisture away from oil/shortening to help maintain its quality. Filtering the oil/ shortening removes crumbs which will help maintain quality and can extend its life.

#### Typical French Fry Cook Times (m:s)



	Temperature		
	350 °F	360 °F	370 °F
Fry Thickness	(177 °C)	(182 °C)	(188 °C)
Thin	2:45	2:30	2:15
Medium	3:45	3:30	3:15
Thick	4:15	4:00	3:45

This table is for reference only. Refer to the product manufacturer's specifications to determine exact cook times and temperatures.

### 4.3. BASKET LIFT OPERATION

If the appliance is equipped with basket lifts, place the basket onto the basket lift prior to starting the timer(s). The basket(s) will be lowered into the cook tank when a product key is pressed. At the end of the preset cooking time, the basket lift will raise the basket out of the cook tank. Canceling the cook by pressing and holding the cook timer button will raise the basket out of the oil. Cook timer keys L through 5 will operate the right-hand basket lift. Keys 6 through R will operate the left-hand basket lift.

### 4.4 FRESH OIL TOP OFF FUNCTION

To add fresh oil to the fry tank on demand, press and hold the  key. Release the  key when the desired oil level is reached in the tank.

Use the Left or Right key to top off the Left or Right vat, respectively for split vat models.

Manual top offs are not permitted while there is an active cook in process.

### 4.5 AUTOMATIC OIL TOP OFF SYSTEM (OPTION)

Pitco offers the "Automatic Oil Level Control" option (Auto-Top Off) to maintain the optimal oil level in your Pitco fryer. This optional system minimizes the need for the operator's attention during busy cooking hours. The system maintains oil levels in the frying vat by adding small amounts of fresh oil when appropriate. Replenishment oil is drawn from a Jug In Box (JIB) located in one of the cabinets in a multiple vat build. Alternately, the JIB can be remotely located within nine feet of the fryer. The system can also accommodate a bulk oil system if equipped. There are specific conditions during which fresh oil cannot be added to the vat by the automatic system:

- |                  |                               |
|------------------|-------------------------------|
| 1) Cook Cycle    | 4) Filtering Cycle            |
| 2) Heating Cycle | 5) Control in the "OFF" state |
| 3) Melt Cycle    |                               |



# OIL MANAGEMENT



## 4.6 QUICK STRAIN FILTERING

When the controller indicates the need to perform a “Quick Filtering” as soon as business levels permit. For more thorough filtering/cleaning operations refer to the Preventative maintenance section of this document or the separate controller manual that was provided with your appliance.



### 4.6.1. NON-AUTO Filter models

**WARNING:** Before filtering ensure that filter pan is in place and empty. Wear proper personal protective equipment while filtering.

1. With Fryer ON and oil above the filter temperature, Pull the BLUE drain handle to initiate filter prompting on the control. The controller will display 'FILTER?'
2. PRESS the 'YES' key, then press the TANK FILL key  to turn pump ON.
3. Follow the store procedures for cleaning and wait for the filter timer to end.
4. When filter timer ends, push the blue handle back in to close drain. The pump will refill the fry tank.
5. When bubbles appear in oil, press the TANK FILL key  to turn pump to OFF.
6. FILTER ONLY ONE TANK AT A TIME, the filter pan may overflow.

### 4.6.2 AUTO FILTER MODELS

**WARNING:** Before filtering ensure that filter pan is in place and empty. Wear proper personal protective equipment while filtering.

1. Ensure that oil temperature is above Filter Temperature. Press the Filter button  on the controller to initiate auto-filter prompting.
2. PRESS 'YES' key to begin auto-filter process and follow the prompts on the controller to continue the auto filter process.
3. Wait until the auto filter process completes.
4. When prompted by the controller, verify that the oil in the frypot has reached an appropriate level. If the filter pan is empty, press the 'YES' key to complete the filter process. If there is still oil in the filter pan, press the 'NO' key to run the pump for an additional 20 seconds.

**NOTE:** 'NO' may be selected for 'Is vat full' a maximum of three times. The fourth time that 'NO' is selected the fryer will turn OFF and display 'POSSIBLE FILTER ISSUE – CHECK AND RESOLVE'. Press the 'YES' key to acknowledge.



## 5 PREVENTATIVE MAINTENANCE

### 5.1. DAILY PREVENTATIVE MAINTENANCE

Performing the preventative maintenance steps below daily will keep your equipment safe and at peak performance. During the cooking process, oil/shortening may spill and splatter and requires immediate attention. During the cooking process, particles, crumbs and crackling collect inside the fry tank reducing product quality and decreasing oil/shortening life. If you are producing high quantities of fried food and/or frying heavily battered food, it will be necessary to perform these steps more than once a day.



#### WARNING

**Serious injury could result from direct contact with hot surfaces and/or oil. Always wear apron, heat resistant gloves for skin protection and goggles for eye protection.**

#### 5.1.1 DAILY FILTERING



At least daily, a complete filter cycle is required, preferably two. Make sure a clean filter is installed every day.

For manual filtering refer to the following procedure:

1. Ensure that the filter pan is in place and empty. Turn the appliance OFF. Pull the blue drain handle to drain oil/shortening from the cooker tank into the filter pan.
2. Using a water dampened clean cloth, wipe the insides of the fry pot to remove crumbs and debris. Scrub crumb ring in frypot with abrasive pad if needed. REMOVE ALL MOISTURE from the tank before proceeding to the next step.
3. Press the  key to turn the pump on. It is recommended to allow the oil to circulate for 5-10 minutes.
4. To refill the tank, push the blue drain handle in. Ensure that the oil/shortening level is to the level line. Additional oil may need to be added to the cook tank
5. When the tank has completed filling, press the  key to deactivate the pump. The oil/shortening in the fryer is now filtered.
7. Clean the filter pan and replace the filter media following the procedures mentioned in this manual.

For Automated Filtering, refer to the following procedure:

Ensure that the oil temperature is above allowable filter temperature and that the filter pan is properly in place and empty before performing this procedure.

1. Turn the fryer 'OFF'.
2. Push and hold the key  enter the Fryer Control Menu.
3. Press the #1 key. The control will display **TOGL OPN**.
4. Press the #6 key (YES). The drain valve will open and the oil will drain from the tank into the filter pan and the control will display **TOGL CLS**.
5. With the oil drained into the filter pan you may clean the fry tank. Using a water dampened clean cloth, wipe the insides of the fry pot to remove crumbs and debris. Scrub crumb ring in frypot with abrasive pad if needed. REMOVE ALL MOISTURE from the tank before proceeding to the next step.
6. When cleaning has been completed, press the #6 key to close the drain valve. The control will display **TOGL OPN**.
7. To return the oil to the fry tank, press the L key. The control will display **TOGL ON**.
8. Press the #6 key (YES) to turn the filter motor on and begin returning the oil to the fry tank. The control will display **TOGL OFF**.
9. When the tank is full press the #6 key (YES) to turn the filter pump OFF. The control will display will show **TOGL ON**.
10. You can now exit the Fryer Control Menu by pressing the  ON/OFF or  Filter key.

You may want to reheat the oil in the fry tank and perform a full auto filter. Additional filtering procedures, settings and control functions can be found in the Control manual that was shipped with your fryer.

## PREVENTATIVE MAINTENANCE

### 5.1.2 FLUSH HOSE OPERATION (if equipped)

The cooker tank can be rinsed cleaned by using a filter flush hose (if equipped). Refer to the previous section in this document to turn the fryer off and drain the oil into the filter pan. During step # 2 for manual models or step #5 for automatic models use the following procedure to operate the filter flush hose.

#### WARNING

Resetting either the filter pump circuit breaker or the filter pump motor thermal overload may cause unexpected hot oil discharge if a refill switch or flush hose valve (if equipped) is left in the ON position. Always verify the appliance is turned OFF and that the filter return switches, or the flush hose valves (if equipped) are OFF and safely positioned before resetting the breaker or thermal overload.

#### WARNING

ALWAYS use Personal Protective Equipment when working with the Flush Hose Option. Contact with hot oil can cause serious injury.

1. Connect the filter flush hose to the quick connecting fitting.
2. **Point the filter hose nozzle outlet into the empty frypot.**
3. Pull the yellow handle to turn the pump on and allow oil/shortening to flow through the flush hose.
4. Use the flush hose to rinse cooking debris from sides and bottom of the fry pot, flushing it through the drain and into the filter pan.
5. When the tank has completed filling, push the yellow handle to deactivate the pump.

### 5.1.3 REPLACING THE FILTER MEDIA (if equipped)

Refer to the following procedure to replace the filter media if the appliance is equipped with a filter drawer. The diagram below shows a Solo Filter style pan and associated parts. Additional filter types are available.

1. Detach the pickup tube from the filter pickup assembly by unscrewing it (counterclockwise), at the knurled fitting, from the threaded fitting on the filter screen.
2. Slide off the filter paper clip and remove used filter paper from filter screen. Clean and completely dry pan and pan components. Replace with new filter paper, ensuring that the hole in the paper is on the top, so that threaded fitting in filter screen protrudes through it.
3. Fold filter paper to the underside of the filter screen and replace filter paper clip.
4. Re-attach filter pickup tube to the filter screen by screwing it (clockwise) into the threaded fitting in filter screen.
5. Reinstall the filter pickup assembly into the filter system by placing the newly covered screen portion of the assembly into the filter pan and connecting the quick disconnect on the filter pickup assembly into white donut fitting on the left-hand side of the appliance. Ensure that it snaps tightly and securely into donut fitting.

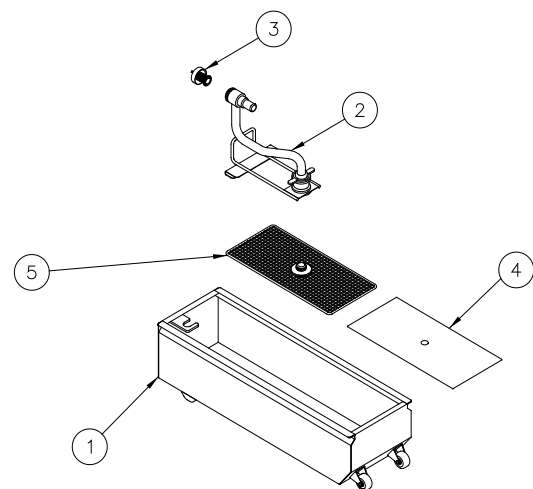

1. Filter Pan (Solo Filter shown)
2. Filter Pickup Assembly
3. Filter Strainer Cap
4. Filter Paper
5. Filter Screen

#### WARNING

The power supply must be disconnected before cleaning and servicing this appliance!

#### WARNING

The contents of the crumb catch and/or filter pan of any filter system must be emptied into a fireproof container at the end of the frying operation each day. Some food particles can spontaneously combust into flames if left soaking in certain oil/shortening materials.

## PREVENTATIVE MAINTENANCE

### 5.1.4 CLEANING THE CABINET

1. Wipe any spilled oil/shortening, dust and lint from the cabinet exterior with a clean damp cloth and a mild food grade detergent. Be careful not to get any water or detergent in the oil/shortening. Use a nonabrasive pad for tougher stains if needed.
2. Remove detergent from all surfaces.
3. Cleaning the interior cabinet requires a clean cloth to remove any oil/shortening, dust, lint or filter powder (i.e.: Magnesol) from the interior of the cabinet.

### 5.1.5 FILTER CLEANING (If Equipped)

1. Unscrew filter strainer cap from pickup tube and remove any crumbs from the slots. Use a clean cloth to remove any remaining crumbs and reattach.
2. Scrape all loose debris and crumbs from filter pickup assembly and filter pan with the filter scoop shovel.
3. Remove filter pickup and place in pot sink, power soak sink or dishwasher for cleaning. Be sure to rinse thoroughly and dry all surfaces before re-assembly.
4. Wipe the filter pan with clean damp cloth and a food grade detergent. If necessary, place pan in pot sink to rinse all the detergent from the surfaces.
5. **CAUTION** - Ensure that all parts and surfaces are completely dry before re-assembling and using.

### 5.1.6 APPLIANCE INSPECTION

- √ Check that the high temperature limit and temperature probe are in the correct position and secured in place. (Refer to illustration on page 11 of this manual).
- √ Check that wires and cords are not frayed or loose in and out of the cabinet.
- √ Check around the appliance for loose parts or accessories that need to be secured or other foreign items (ex: Aerosol cans) that should be removed from the area.
- √ Check for oil/shortening leaks around the inside and outside of the cabinet and around the appliance.

## 5.2 WEEKLY PREVENTATIVE MAINTENANCE

Performing the preventative maintenance steps above on a daily basis will keep your equipment clean and safe. On a weekly basis these additional steps should be performed. **Wear personal protective gear when performing preventative maintenance!**

1. Turn the fryer off. Allow the oil/shortening to cool to room temperature before pulling the fryer away from the hood. Hint: This maintenance may be ideal to perform on the day the oil/shortening is being changed so no oil/shortening is present in the tank or filter.
2. Disconnect the power cord(s), retention lanyard and bulk oil line (if present).
3. Wearing your protective gear, pull the fryer away from the hood.
4. Check that vent hood drip cup is empty and not dripping onto the floor or the appliance.
5. Check that the hood baffles are clean and not dripping oil/shortening onto the floor or the appliance.
6. Clean the fryer exterior area, it may be necessary to use a non-abrasive pad to scour and a putty knife to scrape the oil/shortening buildup. With a clean damp cloth and food grade detergent wipe the area clean.
7. Wipe up any excessive oil/shortening on the power cord(s) and retention lanyard with a dry cloth.
8. Reattach power cord(s), retention lanyard and bulk oil connection (if present) push fryer back under the hood.

#### WARNING

**Serious injury could result from direct contact with hot surfaces and/or oil. ALWAYS wear suitable personal protective equipment.**



#### WARNING

**Read and understand this manual before using this appliance.**



# PREVENTATIVE MAINTENANCE

## 5.3 MONTHLY PREVENTATIVE MAINTENANCE

Food debris and oil/shortening can build up inside the tank. Performing the monthly preventative maintenance steps below will keep your equipment safe and at peak performance. If you are producing high quantities of fried food and/or frying heavily battered food, it may be necessary to clean these components more than once a month.

### 5.3.1 BOIL OUT PROCEDURE

Wear protective gloves and clothing when cleaning and draining the appliance. Oil may spatter and will cause injury to personnel.

1. Read the "operation" section of this manual prior to filling or operating the appliance.
2. Turn the appliance off. Drain all the oil from the tank and allow the tank to cool. The container must also be able to withstand 400°F (205°C) temperatures.
3. Remove baskets, tank rack and basket hanger for cleaning.
4. Remove and discard any large debris inside the tank.
5. Close the drain valve and fill the tank with potable water to the "oil level" line.
6. Place the appliance into boil mode:

Turn the appliance ON. The controller will recognize that there is water in the tank and automatically enter boil mode. To enter boil mode manually, press the Temp Key then keys 2, 1, 2 for degrees F or 1, 0, 0. for degrees C.

7. Once the water reaches a simmer, add 8 to 10 oz. (227 to 283 g) of Pitco cleaner for every 25 lbs. (11.3 kg) of oil/shortening your fryer is rated to hold.
8. Simmer for 1 minute. (The water should never be allowed to boil as this may splash over the tank side and cause permanent damage to the components.)
9. Turn the appliance OFF and allow the fryer to soak for 15 to 30 minutes, allowing the cleaner to soften the oil/shortening deposits and carbon.
10. Scrub the inside of the tank using a cleaning brush safe for hot water. Care must be taken to remove all the foreign material on the tank, heating elements, sidewalls and other components in the tank.
11. Drain and dispose of the cleaning solution. CAUTION: Cleaning Solution is HOT.
12. Once the tank has cooled, rinse with clean potable water thoroughly.
13. Remove all remaining water and residue with a clean dry cloth.
14. Clean and dry baskets, tube rack and basket hanger before reinstalling
15. Close the drain valve and fill the cooker tank with oil.

### 5.3.2 TEMPERATURE CHECK

Use a high grade pyrometer or digital thermometer suitable for temperature up to 380°F (182°C). Place the thermometer in the oil above the tip of the fryer's temperature probe with in 1" (2.54 cm) 25.4 mm). Be sure not to touch the heat tube since this will measure incorrect temperatures.

Check that the controllers set point and thermometer is within +/- 5°F (2.8°C). If your measurement is off, re-measure again before contacting an Authorized Service Company for further assistance.

# PREVENTATIVE MAINTENANCE

## 5.4 ANNUAL/PERIODIC PREVENTATIVE MAINTENANCE AND INSPECTION

This section should ONLY be performed by a qualified service technician as part of a regular kitchen maintenance program. This inspection should take place a minimum of once a year by an Authorized Service Technician recommended by Pitco. It may be necessary perform this inspection more than once a year.

### 5.4.1 SAFETY EVALUATION

- √ Check power cord and plug.
- √ Check all exposed wiring connections, switches, and indicator lights.
- √ Check legs, casters, wheels, plate welds and ensure all nuts and bolts are secured.

### 5.4.2 MECHANICAL INSPECTION

- √ Check fry tank for shortening leaks and excessive oil build up
- √ Check for oil migration (Clean as required)
- √ Check hood drain cup, ensure that it is not dripping onto the appliance. Empty as necessary.
- √ Check hood for clean surface, oil/water condense can drip onto appliance.
- √ Check drain/filtration system (if equipped) for leaks
- √ Check for missing fryer parts.
- √ Check for missing fasteners

### 5.4.3 TEMPERATURE CONTROL SYSTEM

- √ Check electrical connections and harnesses
- √ Check temperature probes and limits for carbon build up and plating. Clean as required
- √ Check proper mounting of probes and sensors and verify all fasteners are secure.
- √ Check DVI Drain Valve Interlock drops out controller.
- √ Check Controller/thermostat features to ensure they are functioning.
- √ Check Temperature Calibration

### 5.4.4 FILTER SYSTEM (IF EQUIPPED)

- √ Check electrical connections and harnesses.
- √ Check IEC power cords are fully engaged and secure.
- √ Check for any air or shortening leaks and for excessive oil build-up.
- √ Check O-Ring on filter pickup tube and replace as needed.
- √ Check filter strainer on pickup tube.
- √ Check operation of drain valve and DVI drain valve interlock.
- √ Check operation of return oil valve and its pump switch.
- √ Check all hardware in filter pan.
- √ Check filter operation by filtering the fryers.
- √ Check pump motor amp draw compare to nameplate amperage.
- √ Check pump and motor; clean any excess oil from pump assembly.
- √ Check all filter hoses for leaks and integrity.

### 5.4.5 HEATING ELEMENT

- √ Check if the element is mechanically strong and in good condition. Look for scale build up and inspect for signs of dry firing.
- √ Verify element wires are in good working condition. Look for damage to wires or frayed insulation. Check that the insulation is dry.
- √ Verify that bulkhead connections/nut is tight and leak free. Look for grease build up and oily surfaces.
- √ Verify amp-draw is within range as compared to the information on the data plate.

### 5.4.6 CONTROL BOX & ELECTRICAL COMPONENTS

- √ Verify that heating contactors are in good condition. Check for worn or pitted contacts. Verify that wires are tight and in good condition.
- √ Verify that all components (transformer, terminal block, relays, drain switches, etc...) are in good condition. Verify that wires are tight and in good condition.
- √ Verify enclosures are free of leaks. Check for water stains and wet surfaces.
- √ Verify that the covers and panels are intact and provide a safe condition. Check for loose parts.
- √ Verify power cord is in good condition. Check for frayed or exposed wires. Verify that the insulation is in good condition and the attachment to the appliance is tight.

## 6 TROUBLESHOOTING

### 6.1 POWER FAILURE

If electric power is removed for any reason, the appliance will shut down. To restart the appliance, follow the appliance start up procedure in the previous sections of this manual

#### WARNING

**DO NOT attempt to operate this appliance during a power outage.**

### 6.2 HIGH TEMPERATURE LIMIT

This appliance is equipped with a high temperature limit switch. The high temperature limit switch will stop the appliance from heating if the oil in the fry pot has reached an unsafe temperature. In the event that the high temperature limit has tripped, refer to the following procedure to reset the switch.

- Turn the appliance off.
- Allow the appliance time to cool to room temperature.
- Add oil to the cook tank as needed.
- Remove the access screw located under the basket support. Refer to Picture 1.



Picture 1

Using a flat blade screw driver, remove the screw marked 'Reset Button' (SELV14 shown; SELV14T reset buttons are under the outer screws.



Picture 2

Using a small diameter rod (1/8" max.) or a Phillips screwdriver, reach through the access hole and press the reset button.

NOTE: A high temperature limit reset tool and spare cover screw are located in the lower left cabinet area of the next to where the JIB is placed. Refer to Picture 3.

- Use the tool provided (Refer to Picture 3) or a small diameter tool ( 1/8" maximum) such as a small Philips screwdriver to press the reset button. Refer to Picture 2.
- Re-install the Access cover screw.
- The high limit switch is now reset and the appliance is ready for start up.
- If the reset becomes tripped again, discontinue using the fryer, and call for service.



Picture 3

High Temperature reset tool and spare cover screw.

#### WARNING



**DO NOT add oil to the fryer until it has been given ample time to cool down. Failure to do so may result in an unsafe condition, damage to the appliance and/or injury to the operator.**

### 6.3 DRAIN VALVE INTERLOCK

Your appliance is equipped with a drain valve interlock circuit; the appliance will stop heating if the tank drain valve is opened. The appliance will turn off, and scroll a message **DRAINING TURN OFF**. Refer to the following procedure to resume operation after the drain valve interlock is tripped.

- Turn the computer OFF (if not already OFF).
- Close the tank drain valve:

Manual models: push the blue handle in. The drain will close.

Automatic models: This system is managed by the controller. If you see this message on the control it is likely due to a fault condition. Call Pitco Technical Support at the number provided in this manual. Other wise, to exit the Fryer Control Menu, press the ON/OFF key  or the Filter key .

- Fill the tank with oi/shortening.
- Turn the computer ON and resume normal operation.

## TROUBLESHOOTING

### 6.4 FRYER TROUBLESHOOTING CHART

PROBLEM	POSSIBLE CAUSES	CORRECTIVE ACTIONS
Computer Controller Display does not illuminate.	No power to appliance	Check main building power supply.
	Circuit breaker has tripped.	Reset circuit breaker at panel.
	Power cord loose or not connected	Connect power cord to power outlet.
	Fuse blown.	Contact Authorized Service Company.
	Defective Transformer.	Contact Authorized Service Company.
	Defective Controller.	Contact Authorized Service Company.
Controller is on, appliance will not heat oil.	Computer is in Melt Cycle.	Allow time for appliance to slowly heat up (melt cycle).
	High Temperature Limit Switch has tripped.	Allow appliance to cool and reset switch.
Appliance will not maintain temperature properly.	Faulty temperature probe.	Contact Authorized Service Company.
	Faulty High Temperature Limit Switch.	Contact Authorized Service Company.
Controller display shows OFF and cannot be turned on.	Faulty Controller.	Contact Authorized Service Company.
Oil temperature is hotter or cooler than controller displays.	Improper temperature calibration.	Calibrate per procedure in this manual.
	Defective temperature probe.	Contact Authorized Service Company.
Controller displays "Draining Turn Off".	Blue drain valve handle is not completely closed (manual models).	Completely close blue drain valve handle.
	Improperly adjusted drain switch	Contact Authorized Service Company.
	Hardware or Comm Fault.	Contact Authorized Service Company.
Controller displays "Probe Op" or "Open".	Defective temperature probe.	Contact Authorized Service Company.

# TROUBLESHOOTING

## 6.5 FILTER TROUBLESHOOTING CHART

PROBLEM	POSSIBLE CAUSES	CORRECTIVE ACTIONS
Filter pump does not activate	The filter pump circuit breaker has tripped.	Reset the filter pump circuit breaker.
	The thermal overload on the pump motor has tripped.	Reset the thermal overload on the motor.*
Oil/shortening is draining slowly or not at all from the fry pot.	Drain valve is closed.	Follow the procedures in this manual to open drain valve through user interface on the controller. (automatic models).*
	Drain valve is not fully open	Pull blue handle out completely (manual models only).
	Defective drain valve.	Contact Authorized Service Company.
	Drain is plugged with debris.	Use the clean out rod to clear the debris from the drain opening.*
Oil/shortening is returning to the fry pot slowly or not at all.	Excessive debris in the filter pan/ dirty filter envelope.	Clean the filter pan/replace the filter envelope.*
	Pump strainer is clogged.	Turn the pump off and remove and clean the pump strainer.*
	Filter pan assembly is not properly installed/filter pickup assembly is not completely pushed in.	Check filter pan for proper installation/push filter pickup in completely.*
	O-rings not sealing on pickup tube	Check and replace O-rings as needed.*
Excessive bubbling occurs in fry pot while oil is being returned.	Pick up tube screen in the filter pan is not tight.	Tighten the tube screen on the filter pickup assembly.*
	Pump strainer cap is loose or missing.	Tighten/replace the pump strainer cap.*
	Filter pan is not properly installed/filter pickup is not completely pushed in.	Check filter pan for proper installation/push filter pickup in completely.*
Oil/shortening is cloudy when returned to tank.	Filter envelope is torn/damaged.	Replace the filter envelope.
	Low oil/shortening temperature	Cloudiness should disappear when oil/shortening is heated.
Drain valve is closed, controller displays "Draining".	Blue drain valve is not completely pushed in.	Push blue drain valve handle in completely (manual models only).
	Improperly adjusted or defective drain switch.	Contact Authorized Service Company.

## TROUBLESHOOTING

### 6.6 CONTROLLER DISPLAYS

Below is a list of common computer controller displays and guidance. For additional computer controller displays and information concerning them, refer to the controller manual that was shipped with your appliance.

Display	Meaning	Action.
<b>OFF</b>	The Controller is OFF.	Press the I/O key to turn the controller on.
<b>MELT L</b>	Fryer is in MELT mode for liquid cooking medium.	Wait for the appliance to heat up.
<b>MELT S</b>	Fryer is in MELT mode for solid shortening.	Wait for the appliance to heat up.
<b>HEATING</b>	Oil/Shortening temperature is low. Fryer is heating.	Wait for the appliance to heat oil.
<b>READY</b>	Oil/Shortening is at temperature.	Perform cooking activities as needed.
<b>DRAINING TURN OFF</b>	The drain valve is open while the appliance is ON.	Turn the appliance OFF. Close drain valve before turning appliance back ON.
<b>HEAT FAILURE</b>	Element housing is in the 'UP' position.	Lower element assembly into oil.
	Float switch (if equipped) is in the down position.	Fill tank with oil/shortening/dislodge the float switch, if stuck.
<b>PROBE OP OPEN</b>	Incorrect probe reading/damaged probe.	Contact Authorized Service Company.
<b>HIGH TMP</b>	Oil/Shortening has reached an unsafe temperature.	Turn off the appliance. Allow time for appliance to cool before restarting.
	Incorrect probe reading/damaged probe.	Contact Authorized Service Company.
<b>SYSTEM FAILURE</b>	Temperature probe is shorted	Contact Authorized Service Company.
<b>POLISH NOW</b>	Indicates that the oil in the vat is in need of polishing.	Operators may, depending on settings, polish now or defer the polish operation for a later time.
<b>FILTSDON</b>	Shows when the number of cooks since the last filter operation exceeds the Cook Counts Allowed Value.	Perform a filter operation as soon as business levels permit.
<b>LOW JIB JIBEMPTY</b>	The JIB is low or empty.	Replace the JIB if it is empty. Refer to the control manual shipped with your appliance to clear this message.
<b>COMMLINK FAILURE</b>	Indicates the computer has lost communication with the autofilter control board. Oil management operations are suspended. Normal cooking activities are unaffected.	Contact Authorized Service Company.



In the event of problems with or questions about your order, please contact the Pitco Frialator factory at:  
(603) 225-6684 World Wide, or, at our Website Address: [www.pitco.com](http://www.pitco.com)

In the event of problems with or questions about your equipment, please contact the Pitco Frialator Authorized Service and Parts representative (ASAP) covering your area, or contact Pitco at the numbers listed to the left.

MAILING ADDRESS – P.O. BOX 501, CONCORD, NH 03302-0501