

RANKIN-DELUX, INC. MODEL RDGM MANUAL CONTROL GRIDDLE

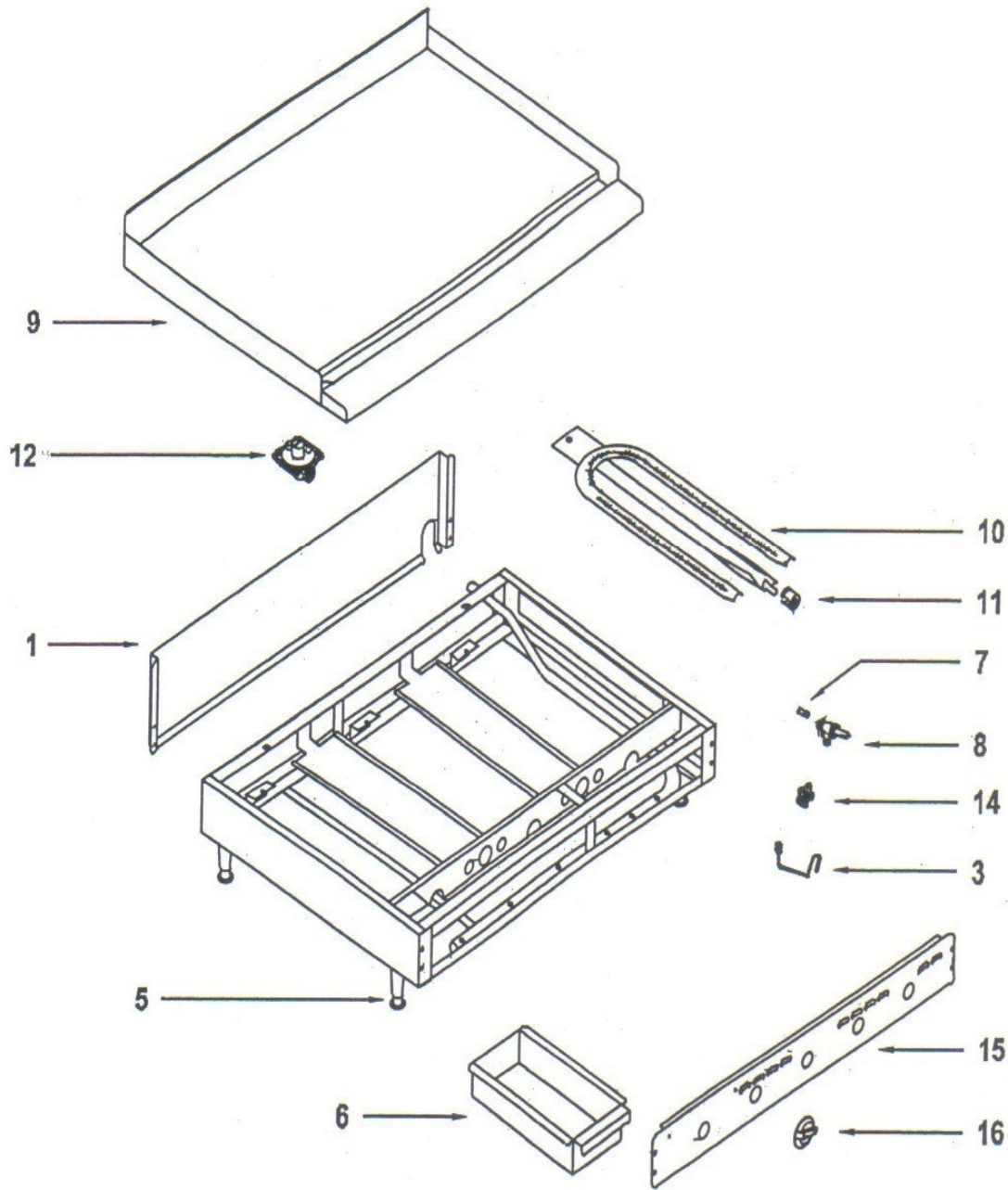

WHEN ORDERING PARTS, PLEASE PROVIDE THE FOLLOWING INFORMATION

- A. MODEL NUMBER C. PART NUMBER
 B. SERIAL NUMBER D. TYPE OF GAS

ITEM	PART #	DESCRIPTION	LIST \$\$	ITEM	PART #	DESCRIPTION	LIST \$\$
1	RDGM-01	BACK PANEL (SPECIFY MODEL)		10	RDGM-10	BURNER WITH AIR SHUTTER	
3	RDGM-03	PILOT TUBE WITH TIP - FOR DOUBLE ADJ. VALVE		11	RDGM-11	AIR SHUTTER ONLY	
3	RDGM-03A	PILOT TUBE WITH TIP - FOR SINGLE ADJ. VALVE		12	RDGM-12	GAS REGULATOR 3/4", NAT	
5	RDGM-05	ADJUSTABLE LEG		12	RDGM-12A	GAS REGULATOR 3/4", LP	
6	RDGM-06	GREASE DRAWER / PAN (6" X 13")		14	RDGM-14	PILOT ADJUSTMENT VALVE - DOUBLE	
7	RDGM-07	ORIFICE, NAT		14	RDGM-14A	PILOT ADJUSTMENT VALVE - SINGLE	
7	RDGM-07A	ORIFICE, LP		15	RDGM-15	FRONT PANEL (SPECIFY MODEL)	
8	RDGM-08	BURNER VALVE WITHOUT ORIFICE		16	RDGM-16	KNOB	
9	RDGM-09	GRIDDLE PLATE ASSEMBLY (SPECIFY MODEL)					