



iCombi® Pro

iCombi® Classic

Original Installation Manual



Unit handover

Dealer:	Installer:

Specify for all queries:

Unit no.:	
Unit type:	
Set to gas type:	
Your unit was checked by:	

WARNING

FOR YOUR SAFETY

Do not store or use petrol or other flammable vapours and liquids near this or any other units.

WARNING

Improper installation, adjustment, modification, maintenance or repair can result in material damage, injuries or death. Read the installation, operating and maintenance instructions carefully before installing or servicing this unit.

NOTICE

Risk from leaking gas

Risk of explosion from leaking gas.

Watch out for the smell of gas.

Avoid any damage to the gas line.

If you smell gas:

- Close the main gas supply.
- Do not touch any electrical controls.
- Ventilate the room well.
- Avoid naked flames or sparking.
- Immediately inform the responsible gas supplier with an external telephone. If the gas provider cannot be reached, call the local fire department.

Table of contents

1 Introduction	6
1.1 Information on this manual	6
1.2 Target group	6
1.3 Copyrights	7
1.4 Conformity	7
1.5 Liability and warranty provisions	7
1.6 Identification of the unit	8
2 Safety	10
2.1 Warning symbols	10
2.2 General safety instructions	10
2.3 Safety instructions for gas units	11
2.4 Intended use	12
3 Product description	13
3.1 Unit description	13
3.2 Technical data	14
3.2.1 Unit dimensions	15
3.2.2 Unit weight	16
3.2.3 Thermal load	17
4 Transport	19
4.1 Centre of mass of unit	19
4.2 Transport with pallet	20
4.3 Transporting without a shipping pallet with a pallet jack	22
4.3.1 Transporting tabletop units without a pallet with a pallet jack	22
4.3.2 Transporting standalone units without a pallet with a pallet jack	23
4.4 Transport with lifting aid	24
5 Placement	28
5.1 Minimum clearance to unit	29
5.1.1 Distance to walls	29
5.1.2 Distance to heat sources	31
5.1.3 Clearance to ceiling	33

5.2	Installation of tabletop units	35
5.2.1	Unit size 6-2/3 GN set up on base frame.....	36
5.2.2	Unit sizes 6-1/1 up to 10-2/1 GN set up on base frame.....	36
5.2.3	Align the base frame horizontally and fasten.....	37
5.2.4	Installation on non-original substructures of the unit manufacturer.....	39
5.3	Installation of standalone units	40
5.3.1	Installing and aligning standalone units.....	40
5.3.2	Securing the standalone unit	43
5.3.3	Aligning the mobile oven rack.....	44
5.4	Fixing the unit.....	46
5.5	Notes on extractor hood.....	47
6	Electrical connection	49
6.1	Regulations for electrical connection	49
6.2	Open the electrical compartment.....	51
6.3	Connecting electric units to the mains.....	55
6.4	Voltage supply (USA and Canada only).....	56
6.5	Conduit connection (USA and Canada only).....	58
6.5.1	Carry out conduit connection.....	58
6.6	Connecting gas units to the mains.....	60
6.7	Close the electrical compartment.....	61
6.8	Connecting the equipotential bonding	61
6.9	Power ratings of different voltage types	63
7	Network connection.....	72
7.1	Notes on network connection.....	72
7.2	Connecting the unit to the network	72
8	Water connection.....	73
8.1	Regulations for water connection	73
8.2	Connecting water inlet	74
8.3	Notes on water treatment.....	75
8.4	Selecting the water filter	75
9	Drain connection	77

9.1	Regulations for drain connection	77
9.2	Connect waste water drain	79
9.3	Additional aeration of the drain (optional).....	80
10	Gas connection for gas units	83
10.1	Regulations for gas connection.....	84
10.2	Connecting the unit to the gas supply	85
10.3	Gas consumption by gas type	86
11	Exhaust gas connection on gas units	91
11.1	Regulations for exhaust gas connection.....	91
11.2	Exhaust gas connection Type A3 and B23.....	92
11.3	Type B13 exhaust gas connection	94
11.4	Type B13BS exhaust gas connection	95
11.5	Exhaust gas collector with and without flow guard for B13 and B13BS	97
12	Initial start-up	99
12.1	Prior to commissioning.....	99
12.2	Perform the self-test.....	100
12.3	Sodium hydroxide free cleaner	101
12.4	iCareSystem AutoDose	102
13	Maintenance	105
13.1	Maintenance notice.....	105
13.2	Replacing air filter	105
14	Decommissioning	106
14.1	Notes on decommissioning	106
14.2	Disposal.....	106

1 Introduction

1.1 Information on this manual

This document is the current version of the installation manual at the time of publication. Please note the relevant version and date.

This document is part of the unit. Read the manual prior to installation. The manual is there to ensure that you use the unit safely and install it properly.

The illustrations in this manual are examples only and may differ from the unit.

This manual applies to the following units:

- LM1: iCombi Pro
- LM2: iCombi Classic

Storage

Keep the installation manual and operating instructions close to the unit. The installation manual must be accessible for professionals authorised by the manufacturer at any time during service calls.

Distribution

This installation manual must be passed on to the owner of the unit.

Circuit diagram

The starter kit contains a circuit diagram for the unit. If the circuit diagram is lost, it can be found in the service parts catalogue and in the TechAssistant app. The TechAssistant app is available from the App Store and Google Play.

Explanation of symbols

- ✓ A condition states all of the requirements that need to be met before the unit can be used.
- 1. One action step describes an action to be performed by the reader.
 - > It expresses a successful interim result.
- 2. Another action step.
 - >> The result reflects the outcome of the action.

1.2 Target group

- This document is intended for skilled technicians, who have been certified by the manufacturer after attending training and safety instructions.
- Installation, inspection, maintenance, and repair work must only be carried out by trained technicians.
- It is recommended that only technicians authorised by the manufacturer perform inspection, maintenance and repair work.
- The unit may not be used, cleaned, or maintained by children. The unit may not be used for play. This is prohibited even under supervision.

- The unit may not be used, cleaned, or maintained by people with limited physical, sensory, or mental capacity or those without the necessary experience or knowledge, unless such people are supervised by a person who is responsible for their safety and who has been informed of the hazards of the unit.
- In order to prevent accidents or damage, the manufacturer recommends that technicians attend training and safety instructions.

1.3 Copyrights

Forwarding product-specific information to third parties is prohibited. We reserve the right to make technical developments and changes in the interest of progress. All rights, including to translation and duplication, are reserved.

1.4 Conformity

Unit conformity refers to the overall unit at the time of delivery. The operator is responsible for ensuring extended conformity following any expansions, modification and connection of additional functions.

Observe the corresponding local and country-specific standards and regulations regarding the installation and operation of commercial cooking units.

Conformity Europe

- The electricity connection has been constructed and tested according to IEC 60335 in consideration of EN 60335 and VDE 0700.
- The water connection has been constructed and tested according to IEC 61770 in consideration of EN 1717 and EN 13077.
- The drain connection meets the requirements of the applicable provisions pursuant to WRAS, SVGW and KIWA and has been tested and certified accordingly.
- The unit is approved for use up to 4,000 m above sea level according to IEC 60335.

Conformity USA and Canada

- The power connection is built and tested according to UL 197 and CSA C22.2 no. 109.

1.5 Liability and warranty provisions

Liability

Installations and repairs not carried out by professionals authorised by the manufacturer or not using original service parts, and technical modifications to the unit, which are not approved by the manufacturer, may void the manufacturer's product liability.

Warranty

Damage occurring as a result of non-compliance with this installation manual is excluded from the warranty.

The following are also excluded from the warranty:

- Damage resulting from improper use, installation, maintenance or repair
- Damage resulting from improper descaling
- Use of the unit for purposes other than those for which it is intended
- Modifications or technical alterations to the unit not authorised by the manufacturer
- Use of non manufacturer–original service parts
- Damage to glass, light bulbs and seal materials

1.6 Identification of the unit

Type plate

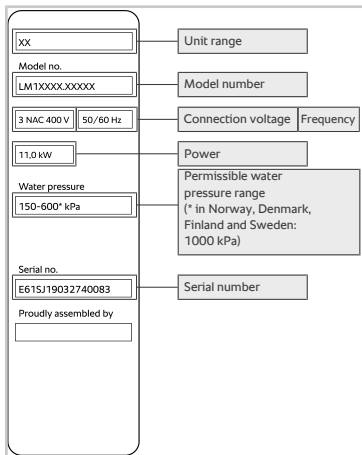

Unit sizes

Unit size type plate	Unit size
LMxxxA...	6 x 2/3 GN
LMxxxB...	6 x 1/1 GN
LMxxxC...	6 x 2/1 GN
LMxxxD...	10 x 1/1 GN
LMxxxE...	10 x 2/1 GN
LMxxxF...	20 x 1/1 GN
LMxxxG...	20 x 2/1 GN

Unit overview

	Tabletop units					Floor units	
	6-2/3	6-1/1	6-2/1	10-1/1	10-2/1	20-1/1	20-2/1
iCombi Pro Electric units	✓	✓	✓	✓	✓	✓	✓
iCombi Pro Gas units		✓	✓	✓	✓	✓	✓
iCombi Classic Electric units		✓	✓	✓	✓	✓	✓
iCombi Classic Gas units		✓	✓	✓	✓	✓	✓

2 Safety

2.1 Warning symbols

 DANGER
Type and source of danger Non-compliance will lead to very serious injury or death. Preventative measures
 WARNING
Type and source of danger Non-compliance can lead to serious injury or death. Preventative measures
 CAUTION
Type and source of danger Non-compliance can lead to minor or moderate injuries. Preventative measures
NOTICE
Failure to heed the NOTICE can lead to damage to the unit.

2.2 General safety instructions

This unit is designed in such a way that it presents no danger if installed according to instructions. This manual describes how to install the unit correctly.

- Adhere to the relevant local regulations and standards in your country.
- Use the lifting aid to lift tabletop units.
- Secure the unit against tipping during transport, after setting up at the installation location.
- Wear appropriate protective clothing, such as protective gloves and safety shoes, when transporting and installing the unit.

- The unit must be installed in a frost-resistant, non-windy and protected environment.
- Do not expose the unit to weather conditions such as rain.
- Only connect the unit in accordance with the installation manual and the information on the nameplate.
- Switch the unit off before disconnecting the mains power or connecting to the mains.
- After use, only transport the unit at ambient temperatures above 0°C [32°F].
- Only store the unit at ambient temperatures above 0°C [32°F].
- Do not operate the unit without an air filter.
- Do not spray aerosols in the vicinity of this unit while it is in operation.
- Check the unit for transport damage. If you suspect the unit has been damaged in transit, contact your dealer/freight forwarder immediately.

2.3 Safety instructions for gas units

Toxic flue gas

Risk of asphyxiation from unauthorised concentration of toxic flue gas.

- Ensure that the installation area can be adequately ventilated.
- Always perform a flue gas analysis when commissioning gas units.
- If an extraction hood is used, make sure that the exhaust hood is switched on when operating the unit.
- Do not put objects on the exhaust pipes.
- Do not obstruct the area around the combustion air extraction with objects.

Risk of fire due to dirty chimney (extraction canopy)

Risk of fire due to irregular cleaning of the chimney (extraction canopy).

- Have the chimney (extraction canopy) cleaned regularly in accordance with the country-specific regulations.

Risk of explosion from leaking gas.

Risk of explosion from leaking gas.

- Watch out for the smell of gas.
- Avoid any damage to the gas line.
- If you smell gas:
 1. Close the main gas supply.
 2. Do not touch any electrical controls.
 3. Ventilate the room well.
 4. Avoid naked flames or sparking.
 5. Immediately inform the responsible gas supplier with an external telephone. If the gas provider cannot be reached, call the local fire department.

NOTICE

Keep the area around the unit free of flammable materials.

2.4 Intended use

This unit has been developed for the preparation of hot food. This unit may only be used commercially, such as in restaurant kitchens and large and commercial kitchens in hospitals, bakeries or butcheries. This unit may not be used outdoors. This unit may not be used for continuous industrial mass production of food.

All other uses are contrary to the intended purpose, and may be dangerous. The manufacturer assumes no liability for the consequences of using the unit contrary to the intended use.

3 Product description

3.1 Unit description

Unit size 6-2/3 GN

The installation connections are on the rear of the unit:

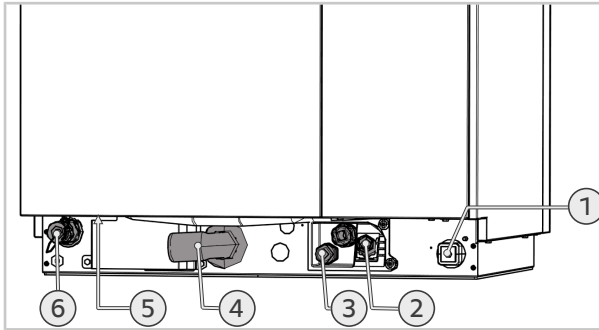

1	Equipotential bonding	2	Water connection
3	Electrical connection	4	Drain connection
5	Safety overflow for drain connection	6	Network connection

Unit sizes 6-1/1 to 10-2/1 GN

The installation connections are on the rear of the unit:

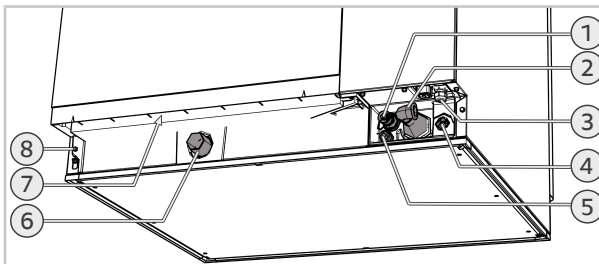

1	Network connection	2	Gas units only: Gas connection Electric units only: Electrical connection
3	Power supply	4	Water connection
5	Optional connection	6	Drain connection
7	Safety overflow for drain connection	8	Equipotential bonding

Unit size 20-1/1 and 20-2/1 GN

The installation connections are on the underside of the unit and go up to the rear of the unit:

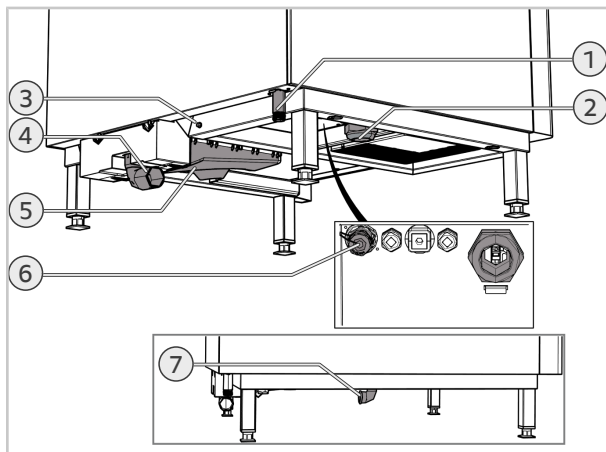

1	Water connection	2	Cable conduit for electrical connection
3	Equipotential bonding	4	Drain connection
5	Safety overflow for drain connection	6	Network connection
7	Gas units only: Gas connection		

3.2 Technical data

Protection class

The unit corresponds to water jet connection class IPX5.

Environmental conditions

- Do not set up the unit in ambient temperatures below 5 °C [41 °F].
- Do not commission the unit in ambient temperatures below 5 °C [41 °F].
- Install the unit in a facility which is sufficiently ventilated with windows or an extraction hood.

Noise emissions value

The sound emission value is <65 dB.

3.2.1 Unit dimensions

Unit size 6-2/3 GN

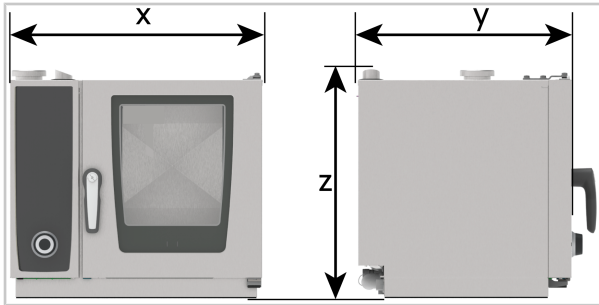

	Width (mm) x	Width (inch)	Depth (mm) y	Depth (inch)	Height (mm) z	Height (inch)
6-2/3	655	25 3/4	555	21 7/8	567	22 3/8

	Depth overall dimension (mm)	Depth overall dimension (inch)	Height over- all dimension (mm)	Height over- all dimension (inch)
6-2/3	621	24 1/2	594	23 1/2

Unit sizes 6-1/1 to 10-2/1 GN

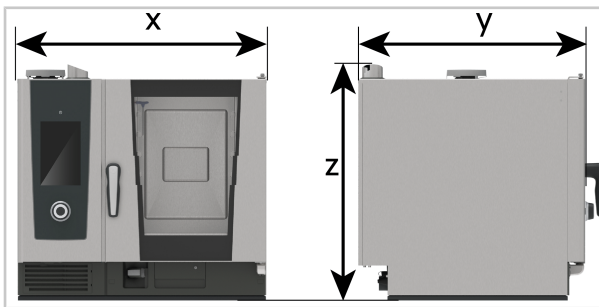

	Width (mm) x	Width (inch)	Depth (mm) y	Depth (inch)	Height (mm) z	Height (inch)
6-1/1	850	33 1/2	775	30 1/2	754	29 5/8
6-2/1	1072	42 1/4	975	38 3/8	754	29 5/8
10-1/1	850	33 1/2	775	30 1/2	1014	39 7/8
10-2/1	1072	42 1/4	975	38 3/8	1014	39 7/8

3 | Product description

	Depth overall dimension (mm)	Depth overall dimension (inch)	Height overall dimension (mm)	Height overall dimension (inch)
6-1/1	842	33 1/8	804	31 5/8
6-2/1	1042	41	804	31 5/8
10-1/1	842	33 1/8	1064	41 7/8
10-2/1	1042	41	1064	41 7/8

Unit size 20-1/1, 20-2/1 GN

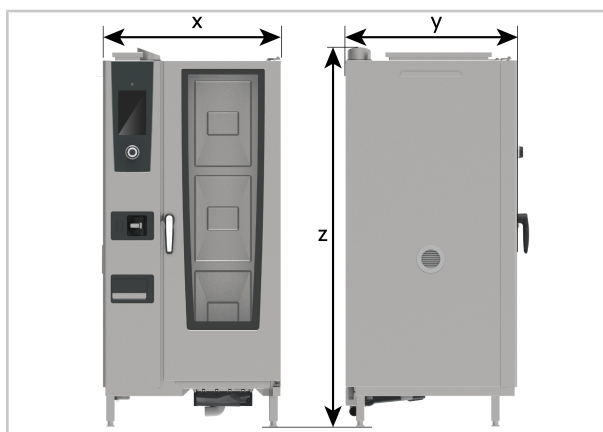

	Width (mm) x	Width (inch)	Depth (mm) y	Depth (inch)	Height (mm) z	Height (inch)
20-1/1	877	34 1/2	847	33 3/8	1807	71 1/8
20-2/1	1082	42 5/8	1052	41 3/8	1807	71 1/8

	Depth overall dimension (mm)	Depth overall dimension (inch)	Height overall dimension (mm)	Height overall dimension (inch)
20-1/1	912.5	35 7/8	1872	73 3/4
20-2/1	1116.5	44	1872	73 3/4

3.2.2 Unit weight

iCombi Pro Electric units

	6-2/3	6-1/1	6-2/1	10-1/1	10-2/1	20-1/1	20-2/1
Weight without packaging (kg)	62	100	135	130	173	254	325

	6-2/3	6-1/1	6-2/1	10-1/1	10-2/1	20-1/1	20-2/1
Weight without packaging (lbs)	137	220	298	287	381	560	717

iCombi Pro Gas units

	6-1/1	10-1/1	6-2/1	10-2/1	20-1/1	20-2/1
Weight without packaging (kg)	114	149	151	192	273	358
Weight without packaging (lbs)	251	328	333	423	602	789

iCombi Classic Electric units

	6-1/1	10-1/1	6-2/1	10-2/1	20-1/1	20-2/1
Weight without packaging (kg)	95	123	128	165	246	313
Weight without packaging (lbs)	209	271	282	364	542	690

iCombi Classic Gas units

	6-1/1	10-1/1	6-2/1	10-2/1	20-1/1	20-2/1
Weight without packaging (kg)	110	143	147	187	267	346
Weight without packaging (lbs)	243	315	324	412	589	763

3.2.3 Thermal load

iCombi Pro Electric units

	6-2/3	6-1/1	6-2/1	10-1/1	10-2/1	20-1/1	20-2/1
Thermal load latent (kJ/h)	1020	2050	3450	3450	6350	6850	10900
Thermal load sensitive (kJ/h)	1350	2523	4583	4583	7982	9115	14420

iCombi Pro Gas units

	6-1/1	10-1/1	6-2/1	10-2/1	20-1/1	20-2/1
Thermal load latent (kJ/h)	2050	3450	3450	6350	6850	10900
Thermal load sensitive (kJ/h)	2523	4583	4583	7982	9115	14420

3 | Product description

iCombi Classic Electric units

	6-1/1	6-2/1	10-1/1	10-2/1	20-1/1	20-2/1
Thermal load latent (kJ/h)	2050	3450	3450	6350	6850	10900
Thermal load sensitive (kJ/h)	2450	4450	4450	7750	8850	14000

iCombi Classic Gas units

	6-1/1	10-1/1	6-2/1	10-2/1	20-1/1	20-2/1
Thermal load latent (kJ/h)	2050	3450	3450	6350	6850	10900
Thermal load sensitive (kJ/h)	2450	4450	4450	7750	8850	14000

We reserve the right to make technical developments/modifications.

4 Transport

CAUTION

Risk of crushing due to the weight of the unit

Hands and fingers can be crushed.

- Use appropriate protective clothing during transport.
- At least 3 persons are required for transportation.

CAUTION

Risk of tipping during transport

Risk of crushing if the unit tips onto persons.

- Note the centre of mass of the unit.
- Make sure that the unit does not tip over during transport or lifting.

NOTICE

Unit damage due to narrow points

Note the width and height of entrances during transport.

Transport options

Unit size	6-2/3	6-1/1 - 10-2/1	20-1/1 - 20-2/1
With shipping pallet	✓	✓	✓
Without a pallet with a pallet jack (only with transport aid)	✓	✓	✓

Transport unit

1. Remove the packaging material.
2. Transport the unit to its place of installation. Adhere to the following descriptions.

4.1 Centre of mass of unit

CAUTION

Risk of crushing and injury if centre of mass not adhered to

If the centre of mass is not adhered to, the unit can tilt when lifted and transported.

- Ensure an even weight distribution of the unit.
- Note the centre of mass of the unit.

NOTICE**Unit size 6-2/3 GN: Damage to the unit if lifted incorrectly**

During transportation, make sure that the air filter box and the USB connection remains intact.

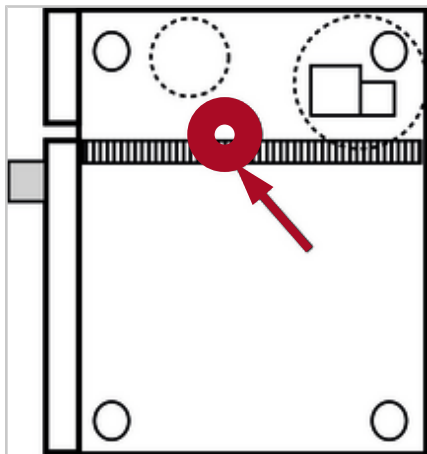
**4.2 Transport with pallet****⚠ CAUTION****Inclinations when transporting with a transport aid**

Risk of crushing and injury during transport with a transport aid over inclinations or uneven floors.

- Do not go over an incline of more than 10°.
- Transport the unit carefully.

NOTICE

Transporting with a transport aid without protection

Transport the unit as far as you can on the pallet. Do not transport the unit without protection with a transport aid or a similar transport tool. For protection, you can use a wooden pallet.

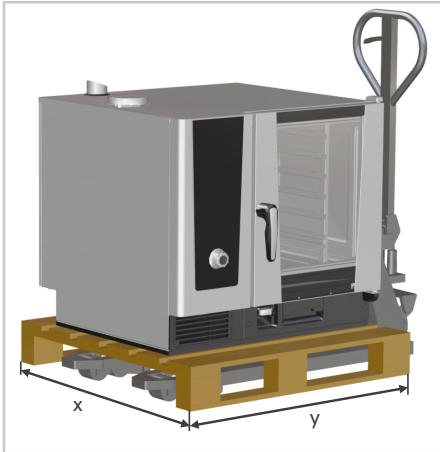

Required door width with transport pallet

Unit size	6-2/3	6-1/1	6-2/1	10-1/1	10-2/1	20-1/1	20-2/1
x (mm)	880	945	1150	945	1150	989	1194
x (inch)	34 5/8	37 1/4	45 1/4	37 1/4	45 1/4	38 7/8	47
y (mm)	930	935	1170	935	1170	969	1174
Y (inches)	36 5/8	36 3/4	46 1/8	36 3/4	46 1/8	38 1/8	46 1/4

Transporting tabletop units with transport pallet

- ✓ The packaging material is removed.
 - ✓ The unit is on the shipping pallet.
 - ✓ The unit is on the base frame.
1. Transport the unit to its place of installation with the transport pallet.
 2. Lift the unit at the lifting points from the transport pallet and place it on its intended installation surface.
- >> The unit is standing on its intended installation surface and is ready for installation.

Transporting standalone units with transport pallet

Upon delivery, standalone units are on a special, separable transport pallet.

- ✓ The packaging material is removed.

- ✓ The unit is on the shipping pallet.
 - ✓ The unit feet are positioned in the rubber frame of the shipping pallet.
1. Transport the unit to its place of installation with the transport pallet. During transport, watch out for protruding parts on the underside of the unit.
- >> The unit is standing on its intended installation surface and is ready for installation.

4.3 Transporting without a shipping pallet with a pallet jack

NOTICE
<p>Transporting without a shipping pallet with a pallet jack</p> <p>Do not transport the unit without protection with a pallet jack. For protection, you can use a wooden pallet or wooden beams.</p>

NOTICE
<p>Unit size 6-2/3 GN: Damage to the unit if lifted incorrectly</p> <p>During transportation, make sure that the air filter box and the USB connection remains intact.</p>

Required door width without a transport pallet

Unit size	6-2/3	6-1/1	6-2/1	10-1/1	10-2/1	20-1/1	20-2/1
x (mm)	630	845	1045	845	1045	925	1145
x (inch)	24 3/4	33 1/4	41 1/8	33 1/4	41 1/8	36 3/8	45 1/8

4.3.1 Transporting tabletop units without a pallet with a pallet jack

- ✓ The packaging material is removed.
 - ✓ The unit is on the base frame.
 - ✓ To avoid scratches on the underside of the unit, provide protection against damage to the unit.
1. Slide the gasket upwards from the slot in the base frame.



2. Place the damage protection on the pallet jack.
3. Lift the unit at the lifting points with the pallet jack.

4. Transport the unit to its intended installation surface.
5. Slide the gasket back into its slot in the base frame.



>> The unit is standing on its intended installation surface and is ready for installation.

4.3.2 Transporting standalone units without a pallet with a pallet jack

- ✓ The packaging material is removed.
 - ✓ The unit is on its feet.
 - ✓ The transport aids are available for use.
 - ✓ The pallet truck is at the lowest setting.
1. Drive the pallet jack underneath the unit from the left or right. Make sure that the pallet jack is at the lowest setting.
 2. Loosen the two screws holding the transport aids together and separate the transport aids.
 3. Place the transport aids between the standalone unit and the pallet jack. Watch out for protruding parts.
 - > The left transport aid must be positioned around 100 mm [4 inches] next to the left unit foot.
 - > The right transport aid must be positioned by the right unit foot.

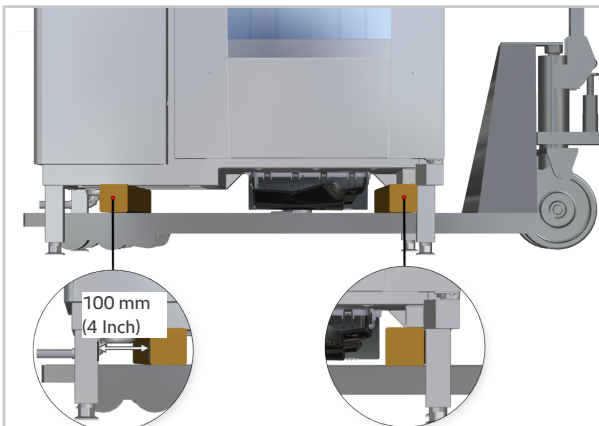

4. Lift the standalone unit with the pallet jack.

5. Transport the unit to its intended installation surface.
- >> The unit is standing on its intended installation surface and is ready for installation.

4.4 Transport with lifting aid

Only transport the unit sizes 6-1/1 to 10-2/1 with the lifting aid.

- Only genuine service parts may be used.
- Check the lifting aid before using. The lifting aid must not be used in the event of wear or damage.
- Use the lifting aid as described. Modifying, extending or alternative use of the lifting aid is not permitted.

The lifting aid may only be lifted by hand. Use with other lifting equipment is not permitted.

CAUTION

Risk of crushing when positioning the unit

Fingers, hands and feet could be crushed beneath the unit.

- Wear appropriate protective clothing when positioning the unit.
- Only lift the unit at the intended lifting points.

CAUTION

Risk of crushing and injury if unit is incorrectly lifted with the lifting aid

Hands, fingers or feet could be crushed.

- Ensure that the lifting aid, installation surface and protective clothing are clean and grease-free.
- Only lift the unit with the bars of the lifting aid by hand. Do not use any mechanical aids to lift the unit.

CAUTION

Sharp edges on the housing

Risk of cuts on the housing when working in the electrical compartment.

- Wear protective gloves.
- Only transport the unit at the approved transport points.

⚠ CAUTION

Risk of crushing and injury during Combi-Duo installation

There is an increased risk of crushing hands and fingers with Combi-Duo installations.

The distance between the bars of the lifting aid and the Combi-Duo kit are extremely small when positioning the unit on the kit.

- Ensure that the unit is lowered carefully on to the kit and is stable when positioned on the installation surface.
- Place the unit on the installation surface so that there is sufficient space between the kit and the lifting aid to protect hands and fingers.

NOTICE

Correctly mounted lifting aid wobbles without load

If the lifting aid is mounted completely and correctly, a slight movement may occur in horizontal direction without load.

The screw connection ensures that the lifting aid cannot slip out of the lifting points. Transportation can take place safely.

Follow the safety instructions in the installation manual.

- ✓ All side panels are closed.
 - ✓ The unit is as close as possible to the final installation surface.
 - ✓ A torque wrench with suitable attachment is ready.
 - ✓ The installation surface, the unit and the lifting aid are clean and grease-free.
 - ✓ Appropriate protective clothing is worn, such as protective gloves.
1. Slide the seal upwards from the slot in the base frame.



2. Insert the four lifting lugs into the slots on the sides of the unit (1) with the top side upwards.

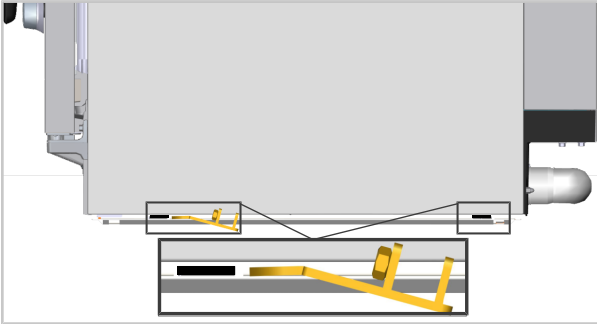

3. Feed in the lug diagonally (2) and turn it clockwise 90° (3).

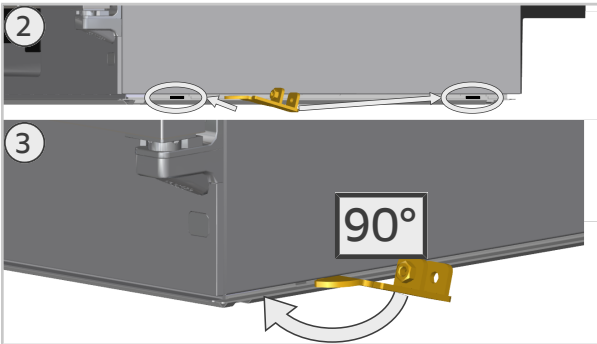

- > The lug can no longer be pulled out (4).
- > The top side of the lifting lugs is marked with TOP.

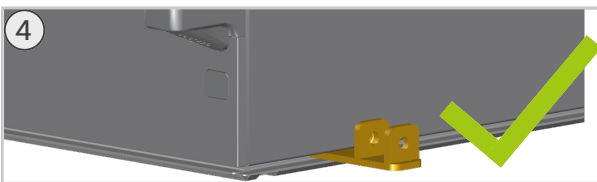

4. Attach the bar to the lifting lugs.
 - > Use the short bars for the unit sizes 6-1/1 and 10-1/1.
 - > Use the long bars for the unit sizes 6-2/1 and 10-2/1.

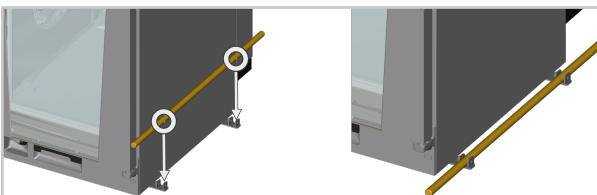

5. Screw the bar in place with the hexagon bolts M8 with a torque of 5 Nm [3 2/3 lbf ft].
 - > Make sure that the bolts are screwed in flush. All four bolts must be tightened accordingly.

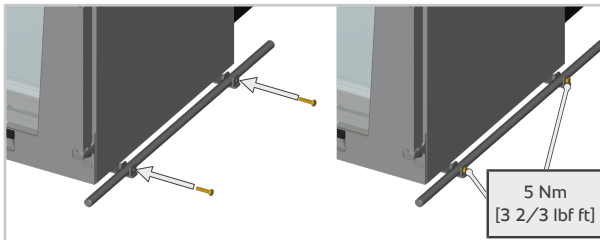

6. Transport the unit with the lifting aid and place it on its intended installation surface.
 - > Lift the unit evenly at the circled lifting points of the bars (1).
 - > Transport the unit with the lifting aid to its intended installation surface (2).

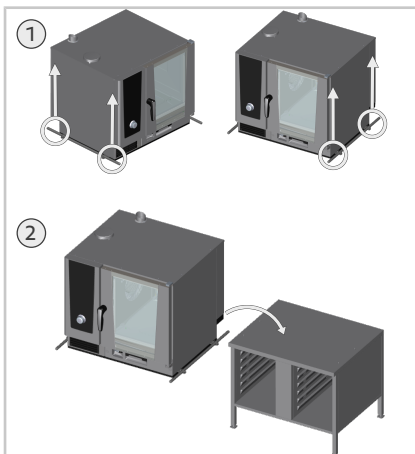

7. Uninstall the lifting aid. To do this, follow the above process in reverse order (Points 2-4).
8. Slide the seal back into its slot in the base frame.
 - >> The unit is positioned on its intended installation surface and is ready for installation.

5 Placement

CAUTION

Risk of crushing when positioning the unit

Fingers, hands and feet could be crushed beneath the unit.

- Wear appropriate protective clothing when positioning the unit.
- Only lift the unit at the intended lifting points.

NOTICE

Unit damage from frost

Ambient temperatures below freezing (frost) may damage the unit. The unit must be installed in a frost-resistant environment.

NOTICE

Unit malfunction due to aspirated atmospheric humidity

Humidity can be aspirated into the air filter from sources of steam near the air filter which would cause the unit to malfunction.

- Avoid having steam sources near the air filter.

NOTICE

Unit malfunction due to blocked air filter

If the air filter is blocked, the unit will not be able to suck in air or, in the case of gas units, combustion air.

- Make sure that the grate of the air filter is not closed or covered.

5.1 Minimum clearance to unit

5.1.1 Distance to walls

Minimum clearance on all sides

Set up the unit taking into account the minimum distances to the wall and objects without heat source. The clearances depend on the unit size, as shown in the following table.

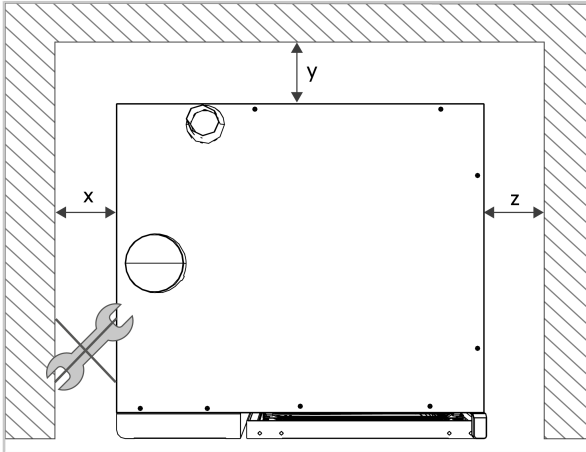

Unit size	6-2/3	6-1/1	6-2/1	10-1/1	10-2/1	20-1/1	20-2/1
x (mm)	10	50	50	50	50	50	50
x (inch)	1/2	2	2	2	2	2	2
y (mm)	10	0	0	0	0	0	0
y (inch)	1/2	0	0	0	0	0	0
z (mm)	10	50	50	50	50	50	50
z (inch)	1/2	2	2	2	2	2	2

The following table only applies to gas units in Japan.

If the wall is flammable, the clearance between the gas units and the wall must be as follows:

Unit size	6-1/1	6-2/1	10-1/1	10-2/1	20-1/1	20-2/1
x (mm)	200					
x (inch)	7 3/4					
y (mm)	150					
y (inch)	6					
z (mm)	200					
z (inch)	7 3/4					

Recommended clearance on left side of the unit

Place the unit with a minimum recommended clearance to the wall on its left to ensure sufficient space on the left side of the unit to perform servicing works at the installation site.

If this clearance on the left side of the unit is not possible, place the unit so that the unit can be pulled out from the installation recess for maintenance work.

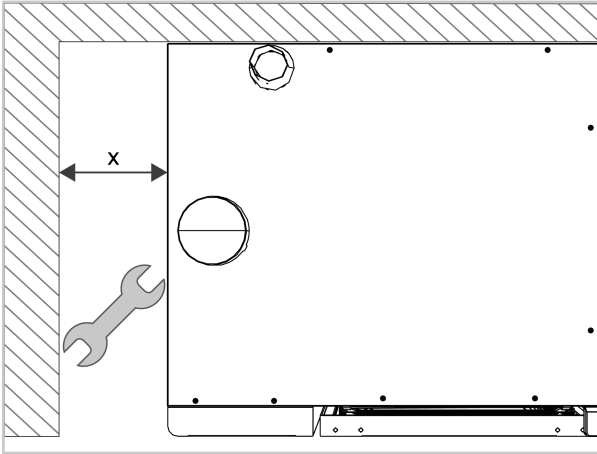

	Distance on the left unit side
x (mm)	500
x (inch)	20

Recommended clearance on right side of the unit

To open the unit door to the first lock lever, place the unit with a minimum recommended clearance to the wall on the right. The clearance depends on the unit size, as shown in the following table.

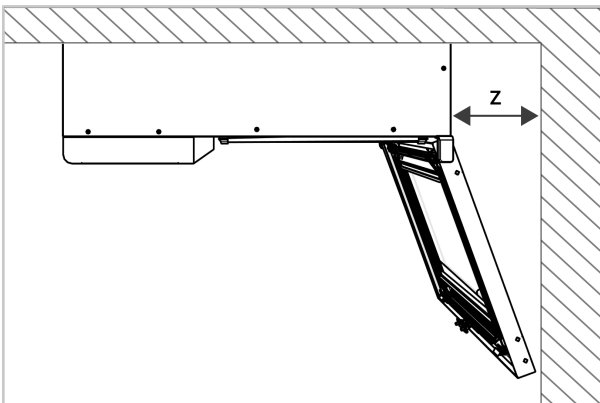

Unit size	6-2/3	6-1/1	6-2/1	10-1/1	10-2/1	20-1/1	20-2/1
z (mm)	214	246	316	246	316	268	338
z (inch)	8 1/2	10	12 1/2	10	12 1/2	11	13

5.1.2 Distance to heat sources

NOTICE

Minimum clearance not adhered to

Place the unit with the minimum clearance to heat sources or open fire required to prevent any damage to the unit or malfunctions.

NOTICE

High ambient temperature next to the installation site (left side of the unit)

If the temperatures at the installation site on the left side of the unit exceed 80°C [176°F], the heating system will be switched off by the automatic emergency shutdown.

NOTICE

High ambient temperatures on the rear side of the unit

Do not place any deep-fat fryers or other heat sources by the rear side of the unit.

Set up the unit with a minimum clearance to heat sources on the left and right.

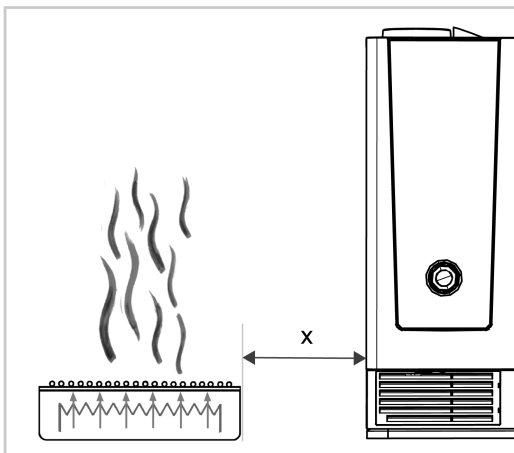

	Minimum clearance heat sources
x [mm]	350
x [inch]	14

Heat shield (optional)

If a sufficient distance to the heat source on the left and right cannot be maintained, an additional heat shield is available to reduce the thermal load.

The heat shields are available for the following unit sizes and combinations:

Unit sizes	6-2/3	6-1/1 - 10-2/1	20-1/1; 20-2/1
Left heat shield	x	x	x
Right heat shield	-	x	-
Heat shield left with Combi-Duo	x	x	-
Right heat shield with Combi-Duo	-	x	-
Left heat shield with UV/UV Plus	x	-	-
Right heat shield with UV/UV Plus	-	-	-
Left heat shield with Combi-Duo and UV/UV Plus	x	-	-
Right heat shield with Combi-Duo and UV/UV Plus	-	-	-

5.1.3 Clearance to ceiling

Electric units

Position the electric unit with a minimum clearance between the unit's vent pipe and the fat filters of the extraction hood/ventilation ceiling.

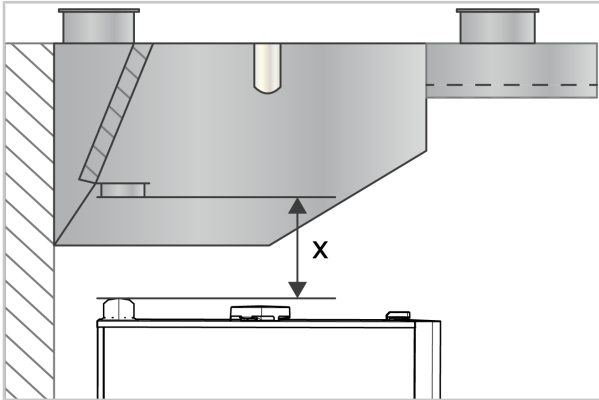

	Minimum clearance ceiling
x [mm]	250
x [inch]	10

Notice:

- We recommend maintaining a clearance of 450 mm for all units and Combi-Duo installations with an UltraVent or UltraVent Plus.
- For tabletop units up to size 10-1/1, this distance can be reduced to at least 250 mm in individual cases after checking all local conditions by an expert.

Gas units

Position the gas unit with a minimum clearance between the unit's flue pipes and the grease filters of the exhaust hood/ventilation ceiling.

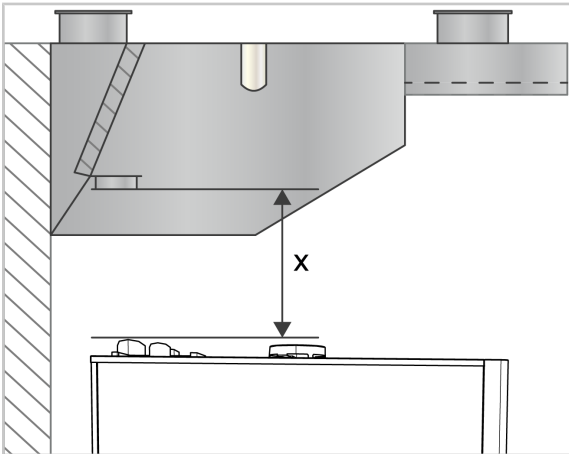

	Minimum clearance ceiling
x [mm]	400 [882]
x [inch]	16

Condensation breaker

If steam from the vent pipe cannot be directed into an extraction hood or a ventilation ceiling, there must be a minimum clearance to the ceiling above the unit.

This space is required to install a condensation breaker so that exhaust air can be directed into non-critical areas.

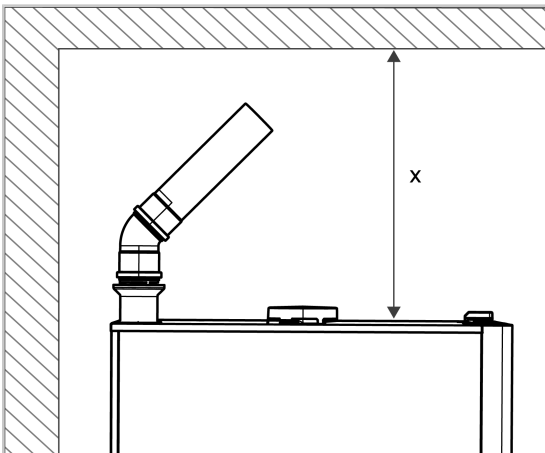

	Minimum clearance ceiling
x [mm]	500
x [inch]	20

5.2 Installation of tabletop units

WARNING

The unit is falling from the installation surface

Risk of crushing and injury from tipping or turning of the unit.

- Do not tip the unit onto the installation surface.
- When turning the unit, make sure that the weight of the unit is evenly distributed and that the unit is completely on the installation surface.

WARNING

Height-adjustment with unit feet or levelling frame

Risk of burning during operation when loading on tray rails above 1600 mm [63 inch].

- Affix the safety label enclosed to the unit.
- Inform the end user about the hazard of elevated rack rails.

NOTICE

Dirty unit due to broken sealing strip

A sealing strip is affixed to the underside of the unit to seal it at the installation site. The sealing strip prevents dirt and liquid from getting underneath the unit. When moving the unit, take care not to damage this seal.

- Equipment is to be sealed to the counter (or floor) to establish proper sanitary operation.
- If the sealing has been carried out according to the specifications, the result should be: prevent liquids from spilling onto adjacent surfaces of the floor or worktop under inaccessible parts of the unit reach.

NOTICE

Usage of sealing tape to prevent contamination

Equipment is to be sealed to the counter (or floor) to establish proper sanitary operation.

There is a sealing tape on the underside of the unit to seal the installation site. The sealing tape prevents dirt and liquid gets under the unit. Be careful when moving the unit. Make sure that the seal is not destroyed.

If the sealing has been carried out according to specifications, the result should be as follows: Prevent liquids from reaching adjacent surfaces of the floor or worktop under inaccessible parts of the unit.

Requirements

- When placing the unit on a base frame or base cabinet, be sure to use only original equipment from the manufacturer for the base frames and cabinets.
- The unit must only be placed on a level installation surface. Unevenness across the width of the unit must be no greater than 1 mm [0.04 inches].
- If the installation surface is not even, use a levelling frame to level the surface.
- The installation surface must be clean and free of grease.
- Set up the unit so that it is freely accessible. The function (e.g. of the cabinet door) must not be impaired by decorations and cladding. Always observe the minimum distances.

See also

- ▣ Installation on non-original substructures of the unit manufacturer [► 39]

5.2.1 Unit size 6-2/3 GN set up on base frame

- ✓ The installation surface is level, clean and free of grease.
 - ✓ 2 screws are provided for fastening.
1. Lift the unit onto the stand.
 2. Position the unit with the spring pins (1). Make sure that the spring pins of the stand fit into the front holes on the underside of the unit.
 3. Insert the 2 screws from underneath into the rear holes and tighten them (2).

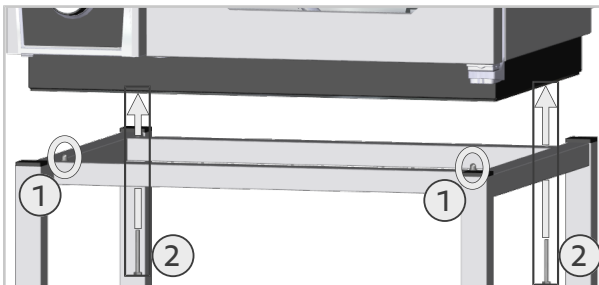

5.2.2 Unit sizes 6-1/1 up to 10-2/1 GN set up on base frame

- ✓ The installation surface is level, clean and free of grease.
1. Lift the unit onto the stand.
 2. Position the unit with the spring pins.

3. Screw the unit to the stand with 2 screws. The diagram indicates the position of the screws in the stand. The screws are attached with the nuts welded in the unit.

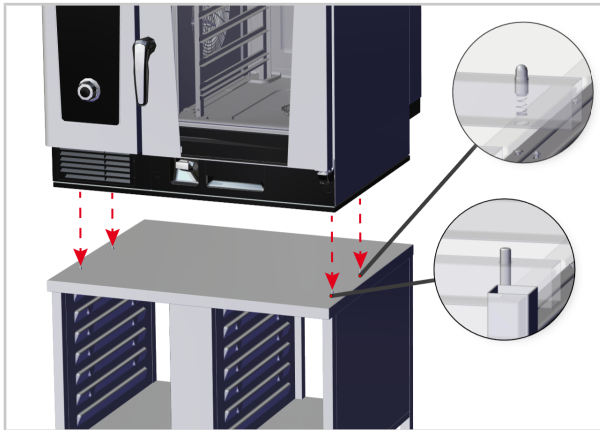

5.2.3 Align the base frame horizontally and fasten

CAUTION

Shifting the unit to the installation position.

Risk of crushing if the unit is shifted.

Gas units can damage gas lines.

- Secure the unit with the fixing kit.

Non-mobile stand

Levelling the stand

- ✓ The unit is positioned on the stand and is standing at its intended installation surface.
1. Place 2 spirit levels on the unit: 1 spirit level along the right edge of the unit and 1 spirit level along the front edge.
 2. Make the unit level on the right by turning the front right and back right feet of the stand.
 3. Make the unit level on the left by turning the front left and back left feet of the stand.

Securing the stand

Secure the stand against slipping with the mounting kit.

The mounting kit including the special label, screws and dowels is not included in the delivery of the unit and can be ordered separately from the manufacturer under article number [8700.0317](#).



Adhere to the clearances of the floor fixings for the relevant unit sizes:



	6-1/1 - 10-1/1	6-2/1 - 10-2/1
x [mm]	755.5	977.5
x [inch]	29 3/4	38 1/2

- ✓ The floor fixing mechanisms and the mounting kit are ready for use.
1. Fix the floor fixings to the floor for the front feet with the special adhesive or screws and anchors. Make sure that both floor fixings with the openings show towards the front.
 2. Insert the stand into the floor fixings.

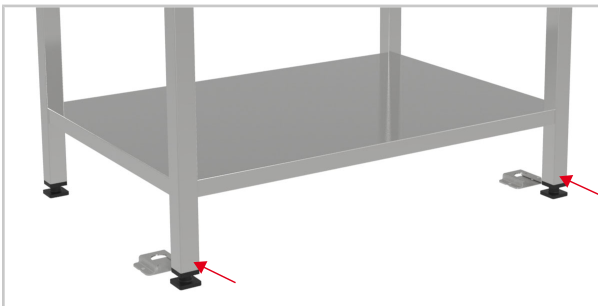

Mobile stand

Align mobile stand

To counter any bumps in the ground and to align the mobile stand, proceed as follows:

1. Loosen the headless screws on the castors with an Allen key.

2. Adjust the height to the castors with a screw wrench until the castors are secure.
3. Secure the grub screw to the castors with a hexagon socket wrench.

Attach the mobile base frame

NOTICE

Damage to electrical or gas lines due to shifting

Also secure the unit with a suitable retention unit to prevent it from slipping on the rear wall (retention units are not included in the scope of delivery).

5.2.4 Installation on non-original substructures of the unit manufacturer

CAUTION

Risk of crushing due to the weight of the unit

Hands, fingers and feet can be crushed.

- Use appropriate protective clothing during transport.
- Use lifting aids if possible, e.g. a carrying strap.

CAUTION

Risk of injury due to inadequate substructure

Setting up the unit on statically inadequate substructures can result in injury and damage to the unit and substructure.

- The substructure must meet the static requirements for the weight and dimensions of the unit. Check whether the static requirements are met.
- The tabletop must be at least 2 mm [1/8 inch] thick.

Units in unit sizes 6-2/3 to 10-2/1 can be installed directly on non-original substructures of the unit manufacturer.

Only install the unit on substructures that are statically suitable for this purpose. Note the unit weight (Unit weight [► 16]) including the maximum load.

If the unit is built on a non-original substructure, the manufacturer's liability shall be voided.

5.3 Installation of standalone units

5.3.1 Installing and aligning standalone units

Lift and set up standalone unit from transport pallet

⚠ CAUTION

Risk of tipping when installing the unit

Risk of crushing if the unit tips onto persons.

- Note the centre of mass of the unit.
- Make sure that the unit does not tip over from the pallet during installation.

⚠ CAUTION

Risk of injury due to the weight of the unit

Personal injury and damage to property due to tipping over of the unit

- At least 2 people are required to set up the unit.

- ✓ The installation surface is level, clean and free of grease.
 - ✓ The transport aid is available.
1. Loosen the screws that connect the transport pallet to the transport aid. Place the transport aids screwed together on the right next to the shipping pallet.

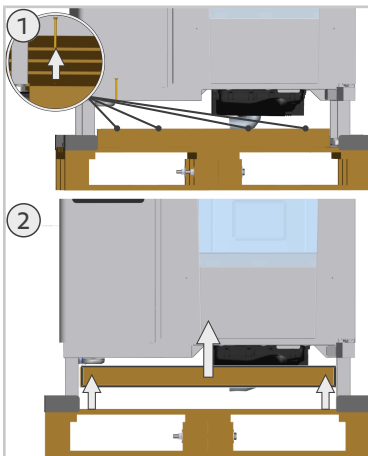

2. Remove the foam rubber pieces next to the unit feet of the transport pallet.

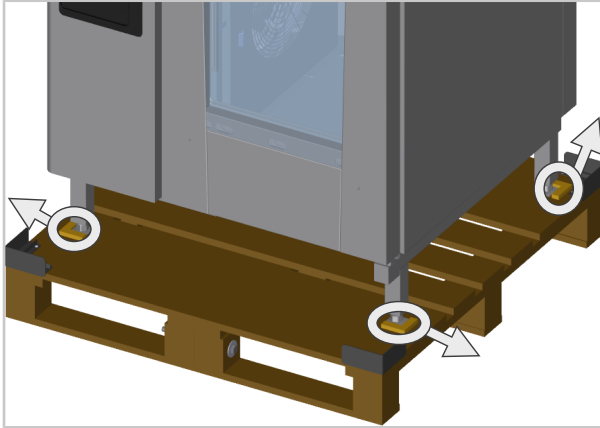

3. Loosen the screws with nut on the split transport pallet.

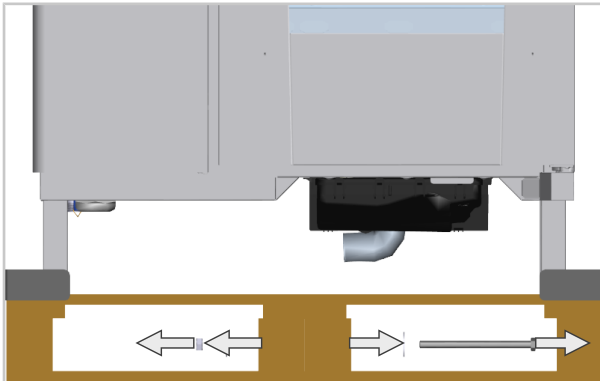

4. Open the cooking cabinet door.

5. Pull the unit downwards by the cooking chamber door. Remove the part of the pallet under the electrical compartment.

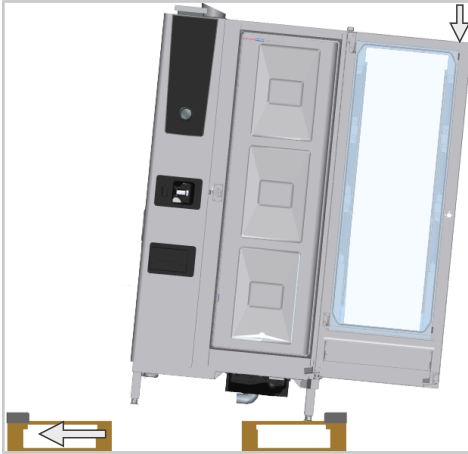

6. Place the unit with the rear unit feet on the installation surface.
7. Gently lift the unit from the cooking chamber door and pull the pallet under the unit.

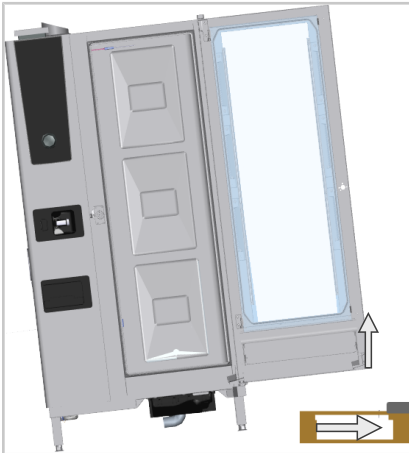

8. Place the unit on the installation surface using the front unit feet.

Aligning the standalone unit

- ✓ The unit is positioned and is standing at its intended installation surface.
1. Place a spirit level in the cooking cabinet of the unit.
 2. Make the unit level on the right by turning the front right and back right unit feet.

3. Make the unit level on the left by turning the front left and back left unit feet.



5.3.2 Securing the standalone unit

CAUTION

Shifting the unit to the installation position.

Risk of crushing if the unit is shifted.

Gas units can damage gas lines.

- Secure the unit with the fixing kit.

Secure the standalone unit against slipping with the mounting kit.

The mounting kit including the special label, screws and dowels is not included in the delivery of the unit and can be ordered separately from the manufacturer under article number [8700.0317](#).



Adhere to the clearances of the floor fixings for the relevant unit sizes:



	20-1/1	20-2/1
x [mm]	741	946
x [inch]	29 1/8	37 1/4

✓ The floor fixing mechanisms and the mounting kit are ready for use.

1. Fix the floor fixings to the floor for the front feet with the special adhesive or screws and anchors. Make sure that both floor fixings with the openings show towards the front.
2. Insert the standalone unit into the floor fixings.

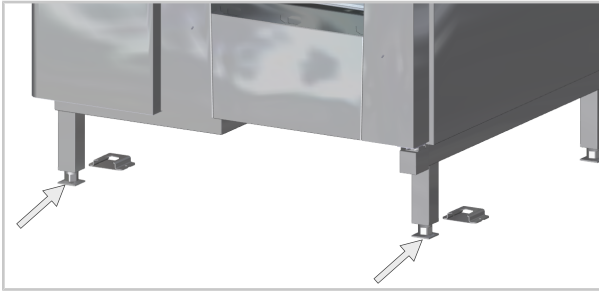

5.3.3 Aligning the mobile oven rack

WARNING

Maximum approach angle of trolley leveling unit is exceeded

Risk of burning due to hot liquid and food if the approach angle is too steep. Ensure that the approach angle of the trolley leveling unit is less than 4 degrees.

NOTICE

Malfunction due to a skewed mobile oven rack

Incorrectly aligning the mobile oven rack may cause the unit to malfunction, such as during cleaning.

Make sure the mobile oven rack is level inside the unit.

1. Make sure there is 205 mm [8 1/8 inches] of clearance between the upper edge of the entry frame and the floor. The clearance is required so that the mobile oven rack can be pushed correctly into the unit.

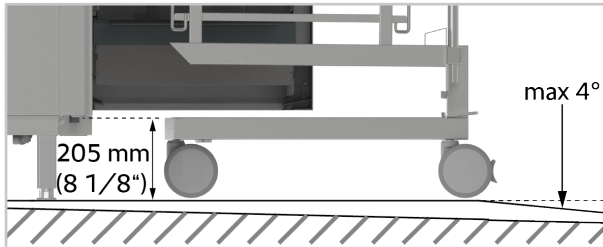

2. Check that the mobile oven rack can be pushed straight into the unit. If this is not the case, use an trolley leveling unit or transfer aid.

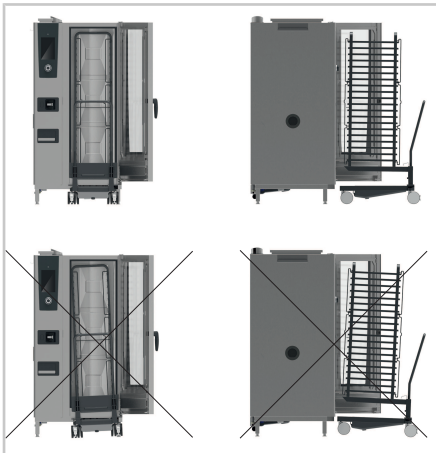

Trolley leveling device and rolling aid

- If the floor is uneven, use an trolley leveling device to compensate the unevenness.

- If there is a gully grid in front of the standalone unit, position a rolling aid near the entry area of the mobile oven rack.



Handle storage

The included holder provides a secure place to store the mobile oven rack handle during cooking.

1. Attach the holder for the handle to the cover of the unit, so that the holder is aligned with the left side panel.
2. Hang the handle in the holder.

5.4 Fixing the unit

CAUTION

Shifting of units to the installation position

Risk of crushing if the units are moved or shifted.

Gas units can damage gas lines.

- Secure the unit with the fixing kit.
- Also secure the unit with a suitable retention unit to prevent it from slipping on the rear wall (retention units are not included in the scope of delivery).

Fixing

Secure units with optional extensions to prevent them from shifting (e.g. marine, Combi-Duo). The mounting kit can be expanded with suitable retaining units.

If available, use the supplied retenting units for options (e.g. bracket for wall mounting).

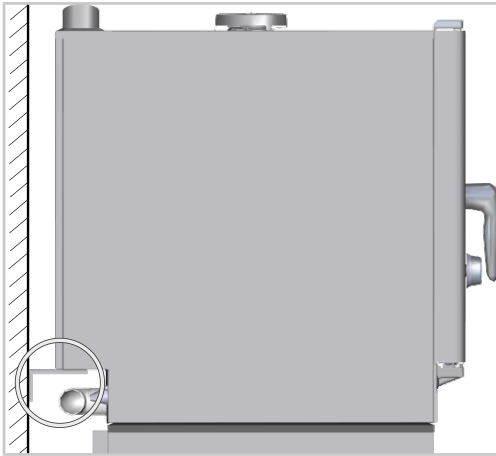

5.5 Notes on extractor hood

DANGER

Toxic flue gas

Risk of asphyxiation from unauthorised concentration of harmful flue gases.

- Ensure that the ventilation options in the installation area are adequate.
- Perform a flue gas analysis prior to commissioning the unit.
- Install the unit under a kitchen ventilation system.
- Only for Japan:
The unit must be installed under an extraction hood.

On-site ventilation

Observe the following instructions when installing an exhaust device:

- VDI Directive 2052, NFPA 96 and local construction authority regulations on exhaust hoods.
- The exhaust hood must protrude 300-500 mm [12 – 20 inches] over the front of the unit.
- USA and Canada: The exhaust hood must protrude 150-500 mm [6 – 20 inches] over the front of the unit.
- When using a VarioSmoker, install the unit under an externally ventilated exhaust device.
- Install a fat filter into the protruding part of the exhaust device.

Extraction hood

An extraction hood (also for retrofitting) is available for the units. To install the extraction hood, follow the installation manual supplied with the extraction hood.

6 Electrical connection

DANGER

High voltages when connecting to the mains power

Danger to life due to high voltage.

- Disconnect from the power supply.
- Make sure the unit is disconnected from the power.

DANGER

Electric shock from incorrect connection

There is a danger to life if the wires are incorrectly connected.

Connect the wires correctly according to their colour coding.

CAUTION

Risk of injury due to improper installation

Use an all-pole disconnecting unit accessible on-site with a contact distance of at least 3 mm [0.12 inch].

NOTICE

Mains voltage does not correspond to unit voltage

Before connecting, check whether the mains voltage corresponds to the required voltage on the type plate of the unit.

6.1 Regulations for electrical connection

- Adhere to the regulations of the VDE and the local energy supplier.
- Connect the unit in accordance with the applicable regulations of your country, federal state, city or local authority.
- Connect the unit to a standard energy supply network.
- The amp draw, contactors and cable cross-sections depend on the following factors:
 - Local regulations
 - Cable length
 - Cable quality
 - Power supply
- For a proper electricity connection, adjust the power ratings to the local circumstances and requirements.
- The maximum connection impedance at the mains connection point is 0.09 Ω for all unit sizes.

- Adhere to the regulations of the NFPA 70/NEC and CSA C22.2.
- Only use power cables in accordance with the provisions of the NEC/NEMA.
- Only connect the unit with copper cables. The cables must comply with the applicable regulations.

Colour coding of wires:

Note the colour coding of wires and local deviations.

Wire colour	Wire function
Yellow/green	Protective conductor
Blue	Neutral conductor (neutral wire)
Brown, grey or black	Phase L1, L2, L3

Residual current circuit breaker

All units are generally equipped with a protective conductor terminal. It may also be necessary to include a RCD type B residual current circuit breaker when installing the unit to comply with country-specific standards and regulations.

Unit sizes 6-1/1 GN to 20-2/1 GN

Connect the unit to a residual current unit according to the table Power ratings of different voltage types [▶ 63].

Unit size 6-2/3 GN

Voltages with neutral conductor (NAC): Connect the unit to a residual current circuit breaker according to the table Power ratings of different voltage types [▶ 63].

Voltages without neutral conductor (AC): Connect the unit to a residual current circuit breaker according to the table Power ratings of different voltage types [▶ 63].

The power connection of the unit must be established so that the mains plug is freely accessible and can be disconnected from the mains at any time.

Notes for standalone units

- The cross-sections of the connection lines depend on current consumption and local regulations.

Notes for UltraVent/UltraVent Plus condensation hood

For units with a condensation hood, both units must be disconnected from the mains prior to servicing work.

Before you disconnect the power cord from the mains or reconnect it to the mains, make sure that the unit is switched off to prevent the condensation hood from running.

Notes for 6-2/3 GN units with an UltraVent/UltraVent Plus condensation hood

- The condensation hood be connected to an electrical supply in line with applicable standards (VDE and UL/CSA NEC regulations).

- The condensation hood is connected to the power supply with a permanent connection. The fixed connection must be accessible on-site with an all-pole disconnecting device with a contact distance of at least 3 mm [1/8 inch].
- If the condensation hood is connected with a power cable, the power cord must always be accessible.
- The condensation hood must be fused with a maximum of 16 A by the customer.
- The condensation hood must be fused with a maximum of 15 A by the customer.
- The condensation hood is equipped with an approx. 2 m [approx. 6 1/2 inches] long connection cable without a plug.
- If the connecting cable is replaced, use a H05 RN-F 3x1.5 mm² quality cable at the very least. The mains power cable may only be replaced by qualified personnel authorised by the manufacturer.
- Before you disconnect the power cord from the mains or reconnect it to the mains, make sure that the unit is switched off to prevent the condensation hood from running.

Notes for units with the Uninterrupted Power Supply (UPS) option

With the UPS option, electronic components can be connected to a stable voltage supply. With this option, a second connection cable for the electronic components will be routed out of the unit. When performing servicing work on the unit, both voltage sources must be disconnected from the mains.

6.2 Open the electrical compartment

The electrical compartment is behind the left side panel.

- ✓ The unit is standing on its intended installation surface.
 - ✓ The unit is switched off.
 - ✓ All power sources are switched off by way of an external circuit breaker.
1. Open the electrical compartment as described below for the relevant unit size.

6 | Electrical connection

Unit size 6-2/3 GN

1. Loosen two screws on the underside of the left side panel and 1 screw on the rear side.

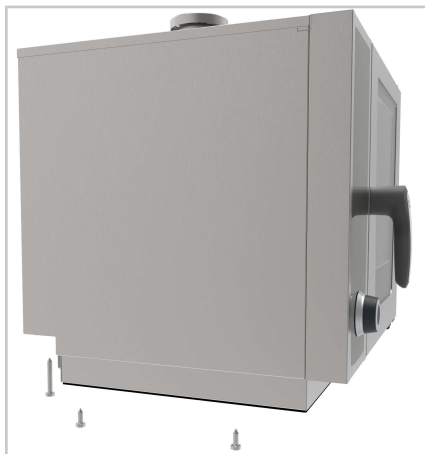

2. Lift up the left side panel from below and pull the side panel downwards away from the unit.



>> The electrical compartment is open.

Unit sizes 6-1/1 GN to 10-2/1 GN

1. Lever out the grating underneath the control panel with a screwdriver.

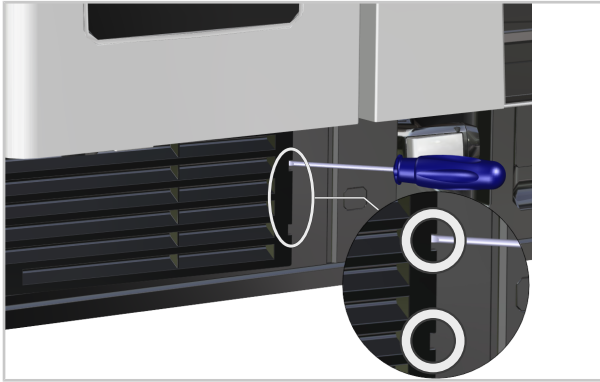

2. Unscrew the blind rivet nuts in the bottom left corner.

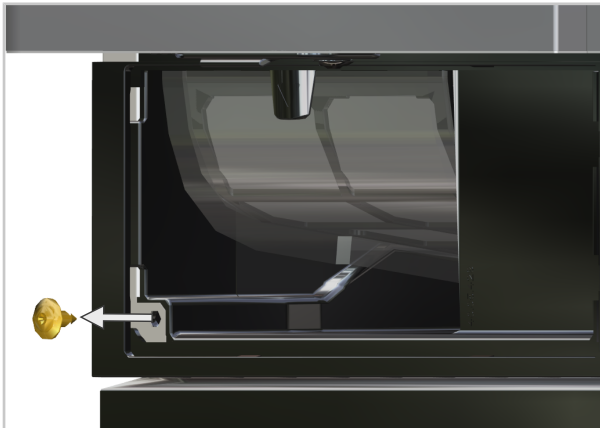

6 | Electrical connection

3. Loosen two screws in the recess of the unit's side panel.

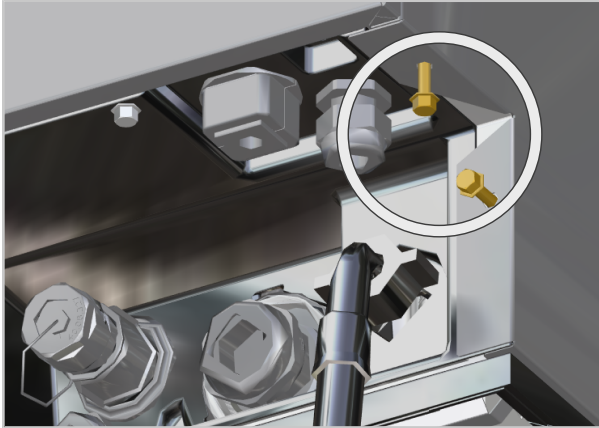

4. Pull the left side panel downwards away from the unit.
 5. Remove the side panel.
- >> The electrical compartment is open.

Unit size 20-1/1 GN, 20-2/1 GN

1. Loosen two screws on the underside of the side panel.
 - > The openings to the screws are closed with a cover. Carefully remove the cover to access the screws.

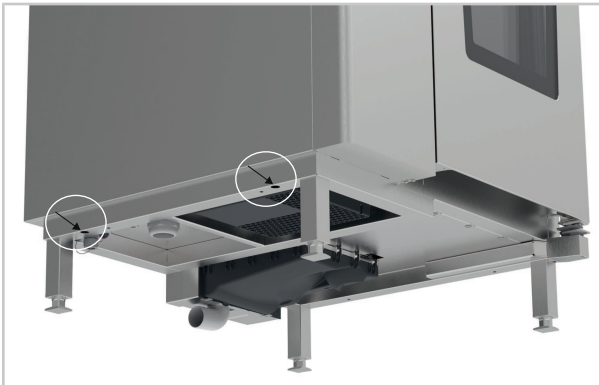

2. Lift up the left side panel from below and pull the side panel downwards away from the unit.

>> The electrical compartment is open.



6.3 Connecting electric units to the mains

Notes on power cord and connection point

- A permanent connection is provided for the electrical connection of the unit.
- Units with a 3 NAC 400 V supply voltage can be connected with a permanent connection or a plug connection.
- A dedicated supply line is available for the unit. The flexible power cord is at least of type H07 RN-F.
- Tabletop units are equipped with power cords without plugs. The cables are around 2.5 m [98.5 inches] in length.
- Standalone units are delivered without mains cables.
- Units with a 3 NAC 400 V supply voltage must be connected to a safety switch by means of a permanent connection (conduit connection).
- A dedicated supply line is available for the unit.
- Units are delivered without mains cables.
- Unit size 6-2/3 GN: The unit is supplied with a mains cable.
- The connection point for the power cable is on the main contactor in the electrical compartment behind the removable left side panel.

Connecting the tabletop unit

- ✓ Unit size 6-2/3 GN: An all-pole disconnection unit with at least a 3 mm [0.12 inches] contact gap must be supplied on site.
- ✓ A residual current circuit breaker according to the table Power ratings of different voltage types ▶ 63] is in place.
- ✓ The mains lead cleat for the supply cable is tightened.
- ✓ The electrical compartment is open.

6 | Electrical connection

1. Lead the mains cable through the opening on the rear side to the connection point in the electrical compartment.
 2. Connect the wires to the connector terminals. Adhere to the following colour coding.
 3. Check that the wires are properly plugged in.
- >> The unit is connected to the mains.

Connecting the standalone unit

- ✓ A residual current circuit breaker according to the table Power ratings of different voltage types [► 63] is in place.
 - ✓ The mains lead cleat for the mains cable is tightened.
 - ✓ The electrical compartment is open.
1. Lead the mains cable through the opening on the underside to the connection point in the electrical compartment.
 2. Tighten the cable screw in the opening.
 3. Open the connector terminals with the appropriate tool and connect the wires. Adhere to the following colour coding.
 4. Check that the wires are properly plugged in.
- >> The unit is connected to the mains.

Connector terminal colour coding

Connection	Wire colour	Connector terminals	Tool (standalone units only)
Phase (non-phase-sequence-dependent)	Grey, black or orange	L1, L2, L3	Allen key
Neutral conductor	Blue	N	Slot screwdriver
Protective conductor	Yellow/green	PE	Hex socket (Torx)

6.4 Voltage supply (USA and Canada only)

- ✓ The unit is switched off.
 - ✓ All power sources are switched off by way of an external circuit breaker.
 - ✓ The electrical compartment is open.
1. Check the power supply at the connection.

- Set the voltage at the switch according to the power supply. In the basic position, the switch is in position 2:

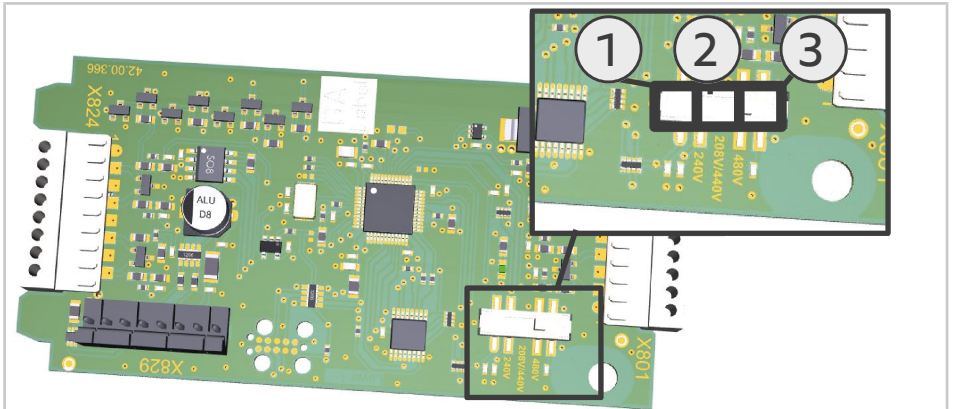

Position	Voltage (V)
1	240
2	208 / 440
3	480

- Close the electrical compartment.
- Connect the unit to the power supply.
- Switch the unit on.
- Select the service level using the control panel. Navigate to the Basic settings - Other - Installation voltage. Set the voltage.

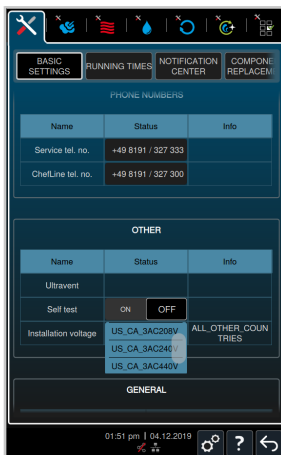

- Switch the unit off and on again. The changes are now applied.
- Perform a performance review. Check that the measured performance values match the information on the nameplate.

>> The voltage was successfully changed.

6.5 Conduit connection (USA and Canada only)

The conduit connection for installing tabletop units is not included with the unit and must be ordered separately.

The conduit connection is required for units with the following voltage variants. Refer to the following table for diameters of conduit connection kits:

Voltage variants	6-1/1	10-1/1	6-2/1	10-2/1
11 - 3 AC240V 60 Hz	3/4 inch	1 inch	1 inch	1 1/4 inch
12 - 3 AC208V 60 Hz				
19 - 2 AC208V 60 Hz	1 inch			
42 - 3 AC440V 60 Hz	1/2 inch	3/4 inch	3/4 inch	1 inch
43 - 3 AC480V 60 Hz	1/2 inch	3/4 inch	3/4 inch	1 inch

6.5.1 Carry out conduit connection

- ✓ The unit is switched off.
 - ✓ All power sources are switched off by way of an external circuit breaker.
 - ✓ The matching pipe adapter is loosely placed on the wires (the pipe adapter is not included).
 - ✓ The wires are inserted in the cable. The lock nut and the seals for the outside of the unit are loosely on the cable.
1. Mount the appropriate pipe adapter to the electrical connection on the back of the unit.

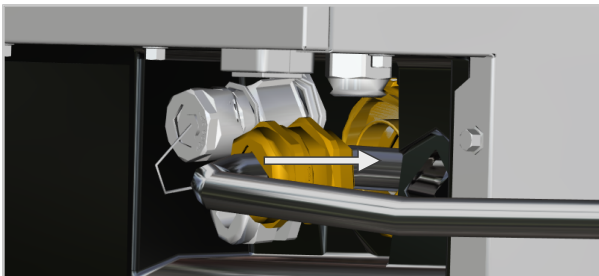

2. Open the left side panel.
 - > The electrical compartment is open.

3. Feed the wires through the connecting pipe.

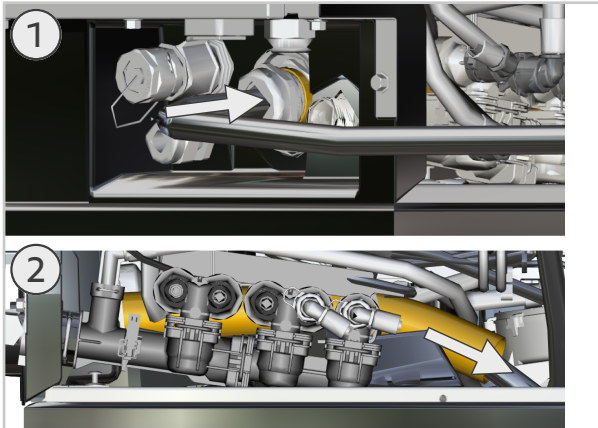

4. Connect the wires to the main protection switch.

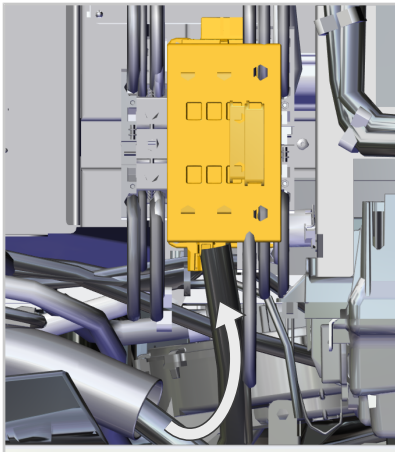

5. Mount the gaskets and the lock nut over the cable to the pipe adapter.

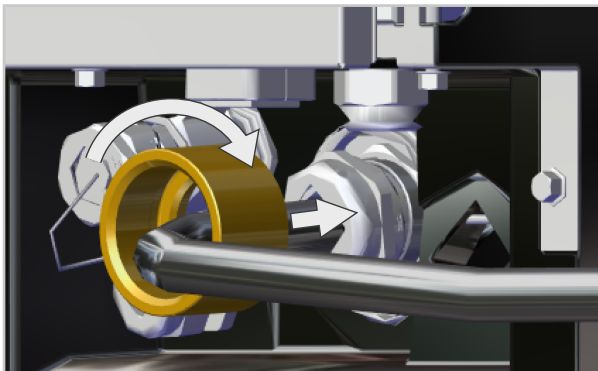

6. Close the left side panel.

>> The installation of the conduit connection is completed on the unit side.

6.6 Connecting gas units to the mains

NOTICE

Incorrect polarity in electrical connection

Note polarity of electrical connection. An error message will appear if polarity is incorrect. The unit is not functional.

Notes on power cord and connection point

- The manufacturer recommends that each unit should have its own fused power supply line.
- Either a permanent connection or a plug connection may be used to connect the units to the power supply.
- A dedicated supply line is available for the unit. The flexible power cord is at least of type H07 RN-F.
- Tabletop units are equipped with power cords without plugs. The cables are around 2.5 m [98.5 inches] in length.
- Standalone units are delivered without mains cables.
- A dedicated supply line is available for the unit.
- The units are delivered with a power cable without plugs.
- Combi-Duo: Both units can be operated via a double socket with a 15 A circuit breaker.
- For gas units, the connection point of the mains cable is located on the flat pins of the integrated mains filter in the electrical compartment.

Establish the connection

- ✓ A type B residual current circuit breaker is provided.
 - ✓ If local regulations do not require a GFCI outlet or fuse, a plug can be connected to the supplied cable on site. A NEMA 5-15 and NEMA 6-15 are included in the optional installation kit.
To avoid false trips when a GFCI is required, this unit is approved for fixed wiring on site in accordance with applicable local and national electrical codes and utility requirements.
 - ✓ The mains lead cleat for the mains cable is tightened.
 - ✓ The electrical compartment is open.
1. Connect the wires to the flat pins. Adhere to the following colour coding.
 2. Check that the wires are properly plugged in.
- >> The unit is connected to the mains.

Colour coding of flat pins

Connection	Wire colour	Flat pin
Phase	Brown, black or grey	L1
Neutral conductor	Blue	N
Protective conductor	Yellow/green	PE

6.7 Close the electrical compartment

NOTICE

Clamped cable

When closing the electrical compartment, make sure that no cables or tubes are trapped.

Unit size 6-2/3 GN

1. Insert the left side panel underneath the unit frame upwards.
 2. Press the side panel upwards.
 3. Tighten 2 screws on the underside of the side panel and 1 screw on the rear side.
- >> The electrical compartment is closed.

Unit sizes 6-1/1 GN to 10-2/1 GN

1. Insert the left side panel underneath the unit frame upwards.
 2. Press the side panel upwards.
 3. Press the side panel inwards in the bottom area.
 - > The front edge is behind the plastic part and the rear edge is above the earthing plate.
 4. Tighten 2 screws on the rear side of the unit.
 5. Put the blind rivet nuts on the front side in the bottom left corner and tighten them.
 6. Insert the grate and press it down.
 7. Check that the floor gasket is positioned correctly.
- >> The electrical compartment is closed.

Unit size 20-1/1 GN - 20-2/1 GN

1. Insert the left side panel underneath the unit frame upwards.
 2. Press the side panel upwards.
 3. Tighten 2 screws on the underside of the side panel.
- >> The electrical compartment is closed.

6.8 Connecting the equipotential bonding

A connection site for equipotential bonding is located on the bottom or the rear of the unit.

Unit size 6-2/3 GN

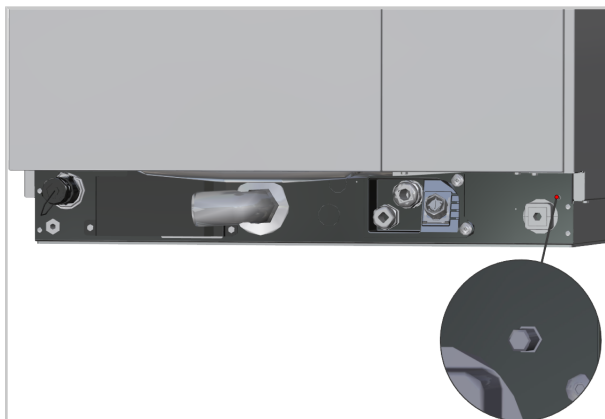

Unit sizes 6-1/1 GN to 10-2/1 GN



Unit size 20-1/1 GN, 20-2/1 GN

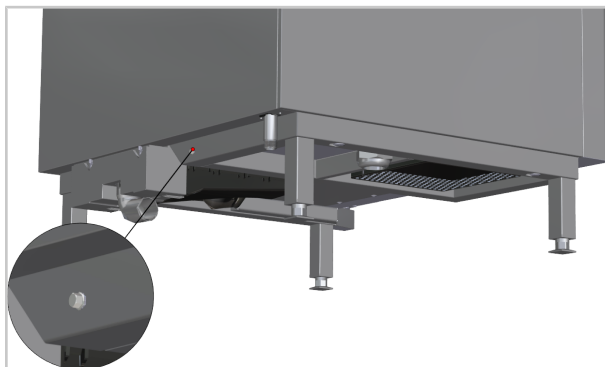

6.9 Power ratings of different voltage types

Maximum connection voltage

- Maximum permissible tolerance for input voltage: -15% to +10%
- The unit can be used with frequencies of 50 Hz and 60 Hz without making any technical modifications.
- In the scope of DIN VDE 0100-410 or DIN VDE 0100-530, we recommend 30 mA tripping current per unit.

iCombi Pro, iCombi Classic Electric units

	Hz	Current consumption (A)	Power (kW)	Fuse (A)	RCD type
6-2/3 (1 NAC 230 V)	50/60	23.1	5.3	25	F/B
6-1/1 E (1 NAC 230 V)	50/60	47	10.8	50	F/B

	Hz	Current consumption (A)	Power (kW)	Fuse (A)	RCD type
6-2/3 (1 NAC 240 V)	50/60	24	5.7	25	F/B
6-1/1 E (1 NAC 240 V)	50/60	48.8	11.7	50	F/B

	Hz	Current consumption (A)	Power (kW)	Fuse (A)	RCD type
6-2/3 (1 ph 208 V)	60	27.4	5.7	50	B
6-1/1 E (1 ph 208 V)	60	51.9	10.8	70	B

	Hz	Current consumption (A)	Power (kW)	Fuse (A)	RCD type
6-2/3 (2 AC 230 V)	50/60	23.1	5.3	25	B
6-1/1 E (2 AC 230 V)	50/60	47	10.8	50	B

	Hz	Current consumption (A)	Power (kW)	Fuse (A)	RCD type
6-2/3 (2 AC 240 V)	50/60	24	5.7	25	B
6-1/1 E (2 AC 240 V)	50/60	48.8	11.7	50	B

6 | Electrical connection

	Hz	Current consumption (A)	Power (kW)	Fuse (A)	RCD type
6-2/3 (1 ph 240 V)	50/60	24	5.7	50	B
6-1/1 E (1 ph 240 V)	50/60	45	10.8	60	B

	Hz	Current consumption (A)	Power (kW)	Fuse (A)	RCD type
6-2/3 (3 AC 200 V)	50/60	15.9	5.3	16	B
6-1/1 E (3 AC 200 V)	50/60	29.2	10.1	32	B
6-2/1 E (3 AC 200 V)	50/60	60	20.8	63	B
10-1/1 E (3 AC 200 V)	50/60	50.5	17.5	63	B
10-2/1 E (3 AC 200 V)	50/60	99.9	34.6	100	B
20-1/1 E (3 AC 200 V)	50/60	99.6	34.5	100	B
20-2/1 E (3 AC 200 V)	50/60	181.9	63	200	B

	Hz	Current consumption (A)	Power (kW)	Fuse (A)	RCD type
6-2/3 (3 ph 208 V)	60	15.9	5.7	30	B
6-1/1 E (3 ph 208 V)	60	30	10.8	40	B
6-2/1 E (3 ph 208 V)	60	62.5	22.4	80	B
10-1/1 E (3 ph 208 V)	60	52.8	18.9	70	B
10-2/1 E (3 ph 208 V)	60	103.9	37.4	150	B
20-1/1 E (3 ph 208 V)	60	105.6	38	150	B
20-2/1 E (3 ph 208 V)	60	189	67.9	250	B

	Hz	Current consumption (A)	Power (kW)	Fuse (A)	RCD type
6-2/3 (3 AC 220 V)	50/60	14.4	5.3	20	B
6-1/1 E (3 AC 220 V)	50/60	26	9.9	32	B
6-2/1 E (3 AC 220 V)	50/60	54.1	20.6	63	B
10-1/1 E (3 AC 220 V)	50/60	45.4	17.3	50	B
10-2/1 E (3 AC 220 V)	50/60	90	34.3	100	B
20-1/1 E (3 AC 220 V)	50/60	89.5	34.1	100	B
20-2/1 E (3 AC 220 V)	50/60	163.8	62.4	200	B

	Hz	Current consumption (A)	Power (kW)	Fuse (A)	RCD type
6-2/3 (3 AC 230 V)	50/60	14.9	5.7	16	B
6-1/1 E (3 AC 230 V)	50/60	27.1	10.8	32	B
6-2/1 E (3 AC 230 V)	50/60	56.2	22.4	63	B
10-1/1 E (3 AC 230 V)	50/60	47.4	18.9	50	B
10-2/1 E (3 AC 230 V)	50/60	93.9	37.4	100	B
20-1/1 E (3 AC 230 V)	50/60	93.4	37.2	100	B
20-2/1 E (3 AC 230 V)	50/60	170.4	67.9	200	B

	Hz	Current consumption (A)	Power (kW)	Fuse (A)	RCD type
6-2/3 (3 AC 240 V)	50/60	15.5	6.2	16	B
6-1/1 E (3 AC 240 V)	50/60	28.1	11.7	32	B
6-2/1 E (3 AC 240 V)	50/60	58.5	24.3	63	B
10-1/1 E (3 AC 240 V)	50/60	49.3	20.5	50	B
10-2/1 E (3 AC 240 V)	50/60	97.2	40.6	100	B
20-1/1 E (3 AC 240 V)	50/60	97.2	40.4	100	B
20-2/1 E (3 AC 240 V)	50/60	177.5	73.8	200	B

	Hz	Current consumption (A)	Power (kW)	Fuse (A)	RCD type
6-1/1 E (3 AC 400 V)	50/60	15.6	10.8	16	B
6-2/1 E (3 AC 400 V)	50/60	32.3	22.4	35	B
10-1/1 E (3 AC 400 V)	50/60	27.3	18.9	32	B
10-2/1 E (3 AC 400 V)	50/60	54	37.4	63	B
20-1/1 E (3 AC 400 V)	50/60	53.7	37.2	63	B
20-2/1 E (3 AC 400 V)	50/60	98	67.9	100	B

	Hz	Current consumption (A)	Power (kW)	Fuse (A)	RCD type
6-1/1 E (3 AC 415 V)	50/60	15	10.8	16	B
6-2/1 E (3 AC 415 V)	50/60	33.7	24.2	35	B
10-1/1 E (3 AC 415 V)	50/60	28.5	20.5	32	B

6 | Electrical connection

	Hz	Current consumption (A)	Power (kW)	Fuse (A)	RCD type
10-2/1 E (3 AC 415 V)	50/60	56.5	40.6	63	B
20-1/1 E (3 AC 415 V)	50/60	56.2	40.4	63	B
20-2/1 E (3 AC 415 V)	50/60	102.7	73.8	125	B

	Hz	Current consumption (A)	Power (kW)	Fuse (A)	RCD type
6-1/1 E (3 AC 440 V)	50/60	14.2	10.8	16	B
6-2/1 E (3 AC 440 V)	50/60	29.4	22.4	32	B
10-1/1 E (3 AC 440 V)	50/60	24.8	18.9	32	B
10-2/1 E (3 AC 440 V)	50/60	49.1	37.4	63	B
20-1/1 E (3 AC 440 V)	50/60	48.8	37.2	63	B
20-2/1 E (3 AC 440 V)	50/60	89.1	67.9	100	B

	Hz	Current consumption (A)	Power (kW)	Fuse (A)	RCD type
6-1/1 E (3 ph 440 V)	60	14.2	10.8	20	B
6-2/1 E (3 ph 440 V)	60	29.5	22.4	40	B
10-1/1 E (3 ph 440 V)	60	25	18.9	35	B
10-2/1 E (3 ph 440 V)	60	49.1	37.4	70	B
20-1/1 E (3 ph 440 V)	60	49.9	38	70	B
20-2/1 E (3 ph 440 V)	60	89.3	67.9	125	B

	Hz	Current consumption (A)	Power (kW)	Fuse (A)	RCD type
6-1/1 E (3 AC 480 V)	50/60	13	10.8	16	B
6-2/1 E (3 AC 480 V)	50/60	26.9	22.4	32	B
10-1/1 E (3 AC 480 V)	50/60	22.7	18.9	25	B
10-2/1 E (3 AC 480 V)	50/60	45	37.4	50	B
20-1/1 E (3 AC 480 V)	50/60	44.7	37.2	50	B
20-2/1 E (3 AC 480 V)	50/60	81.7	67.9	100	B

	Hz	Current consumption (A)	Power (kW)	Fuse (A)	RCD type
6-1/1 E (3 ph 480 V)	60	13	10.8	20	B
6-2/1 E (3 ph 480 V)	60	27.1	22.4	35	B
10-1/1 E (3 ph 480 V)	60	22.9	18.9	30	B
10-2/1 E (3 ph 480 V)	60	45	37.4	60	B
20-1/1 E (3 ph 480 V)	60	45	38	60	B
20-2/1 E (3 ph 480 V)	60	81.9	67.9	125	B

	Hz	Current consumption (A)	Power (kW)	Fuse (A)	RCD type
6-2/3 (3 NAC 400 V)	50/60	9.2	5.7	10	F/B
6-1/1 E (3 NAC 400 V)	50/60	15.6	10.8	16	F/B
6-2/1 E (3 NAC 400 V)	50/60	32.3	22.4	35	B
10-1/1 E (3 NAC 400 V)	50/60	27.3	18.9	32	F/B
10-2/1 E (3 NAC 400 V)	50/60	54	37.4	63	B
20-1/1 E (3 NAC 400 V)	50/60	53.7	37.2	63	F/B
20-2/1 E (3 NAC 400 V)	50/60	98	67.9	100	B

	Hz	Current consumption (A)	Power (kW)	Fuse (A)	RCD type
6-2/3 (3 NAC 415 V)	50/60	9.5	6.3	10	F/B
6-1/1 E (3 NAC 415 V)	50/60	15	10.8	16	F/B
6-2/1 E (3 NAC 415 V)	50/60	33.7	24.2	35	B
10-1/1 E (3 NAC 415 V)	50/60	28.5	20.5	32	F/B
10-2/1 E (3 NAC 415 V)	50/60	56.5	40.6	63	B
20-1/1 E (3 NAC 415 V)	50/60	56.2	40.4	63	F/B
20-2/1 E (3 NAC 415 V)	50/60	94.5	67.9	100	B

	Hz	Current consumption (A)	Power (kW)	Fuse (A)	RCD type
6-2/3 E (3 AC 240 V)	60	15.5	5.7	30	B
6-1/1 E (3 AC 240 V)	60	26	10.8	35	B
6-2/1 E (3 AC 240 V)	60	53.9	22.4	70	B

6 | Electrical connection

	Hz	Current consumption (A)	Power (kW)	Fuse (A)	RCD type
10-1/1 E (3 AC 240 V)	60	45.8	18.9	60	B
10-2/1 E (3 AC 240 V)	60	90.1	37.4	125	B
20-1/1 E (3 AC 240 V)	60	91.5	38	125	B
20-2/1 E (3 AC 240 V)	60	163.8	67.9	225	B

	Hz	Current consumption (A)	Power (kW)	Fuse (A)	RCD type
6-2/3 (2 AC 220 V) - Marine	50/60	22	4.84	25	F/B

	Hz	Current consumption (A)	Power (kW)	Fuse (A)	RCD type
6-2/3 (3 AC 220 V) - Marine	50/60	13.3	5	16	B

	Hz	Current consumption (A)	Power (kW)	Fuse (A)	RCD type
6-2/3 (3 NAC 400 V) - Marine	50/60	7.1	4.9	10	F/B

iCombi Pro, iCombi Classic Gas units

	Hz	Current consumption (A)	Power (kW)	Fuse (A)	RCD type
6-1/1 G (1 NAC 100 V)	50/60	3.8	0.38	16	F/B
10-1/1 G (1 NAC 100 V)	50/60	7.5	0.75	16	B
20-1/1 G (1 NAC 100 V)	50/60	12	1.2	16	F/B

	Hz	Current consumption (A)	Power (kW)	Fuse (A)	RCD type
6-1/1 G (1 NAC 110 V)	50/60	5.5	0.6	16	F/B
10-1/1 G (1 NAC 110 V)	50/60	8.3	0.9	16	B
20-1/1 G (1 NAC 110 V)	50/60	11.8	1.3	16	F/B

	Hz	Current consumption (A)	Power (kW)	Fuse (A)	RCD type
6-1/1 G (1 NAC 120 V)	60	5.0	0.6	15	F/B
10-1/1 G (1 NAC 120 V)	60	7.5	0.9	15	B
20-1/1 G (1 NAC 120 V)	60	10.8	1.3	15	F/B
	Hz	Current consumption (A)	Power (kW)	Fuse (A)	RCD type
6-1/1 G (1 NAC 127 V)	50/60	4.7	0.6	16	F/B
10-1/1 G (1 NAC 127 V)	50/60	7.1	0.9	16	B
20-1/1 G (1 NAC 127 V)	50/60	10.2	1.3	16	F/B
	Hz	Current consumption (A)	Power (kW)	Fuse (A)	RCD type
6-1/1 G (1 NAC 230 V)	50/60	2.6	0.6	16	F/B
6-2/1 G (1 NAC 230 V)	50/60	3.9	0.9	16	B
10-1/1 G (1 NAC 230 V)	50/60	3.9	0.9	16	B
10-2/1 G (1 NAC 230 V)	50/60	6.5	1.5	16	B
20-1/1 G (1 NAC 230 V)	50/60	5.7	1.3	16	F/B
20-2/1 G (1 NAC 230 V)	50/60	9.6	2.2	16	B
	Hz	Current consumption (A)	Power (kW)	Fuse (A)	RCD type
6-1/1 G (1 NAC 240 V)	50/60	2.5	0.6	16	F/B
6-2/1 G (1 NAC 240 V)	50/60	3.8	0.9	16	B
10-1/1 G (1 NAC 240 V)	50/60	3.8	0.9	16	B
10-2/1 G (1 NAC 240 V)	50/60	6.3	1.5	16	B
20-1/1 G (1 NAC 240 V)	50/60	5.4	1.3	16	F/B
20-2/1 G (1 NAC 240 V)	50/60	9.2	2.2	16	B
	Hz	Current consumption (A)	Power (kW)	Fuse (A)	RCD type
6-1/1 G (2 AC 200 V)	50/60	1.9	0.38	16	B
6-2/1 G (2 AC 200 V)	50/60	3.3	0.65	16	B

6 | Electrical connection

	Hz	Current consumption (A)	Power (kW)	Fuse (A)	RCD type
10-1/1 G (2 AC 200 V)	50/60	3.8	0.75	16	B
10-2/1 G (2 AC 200 V)	50/60	6.3	1.25	16	B
20-1/1 G (2 AC 200 V)	50/60	6.0	1.2	16	B
20-2/1 G (2 AC 200 V)	50/60	9.5	1.9	16	B

	Hz	Current consumption (A)	Power (kW)	Fuse (A)	RCD type
6-1/1 G (2 AC 208 V)	60	2.9	0.6	15	B
6-2/1 G (2 AC 208 V)	60	4.3	0.9	15	B
10-1/1 G (2 AC 208 V)	60	4.3	0.9	15	B
10-2/1 G (2 AC 208 V)	60	7.2	1.5	15	B
20-1/1 G (2 AC 208 V)	60	6.3	1.3	15	B
20-2/1 G (2 AC 208 V)	60	10.6	2.2	15	B

	Hz	Current consumption (A)	Power (kW)	Fuse (A)	RCD type
6-1/1 G (2 AC 220 V)	50/60	2.7	0.6	16	B
6-2/1 G (2 AC 220 V)	50/60	4.1	0.9	16	B
10-1/1 G (2 AC 220 V)	50/60	4.1	0.9	16	B
10-2/1 G (2 AC 220 V)	50/60	6.8	1.5	16	B
20-1/1 G (2 AC 220 V)	50/60	5.9	1.3	16	B
20-2/1 G (2 AC 220 V)	50/60	10	2.2	16	B

	Hz	Current consumption (A)	Power (kW)	Fuse (A)	RCD type
6-1/1 G (2 AC 230 V)	50/60	2.6	0.6	16	B
6-2/1 G (2 AC 230 V)	50/60	3.9	0.9	16	B
10-1/1 G (2 AC 230 V)	50/60	3.9	0.9	16	B
10-2/1 G (2 AC 230 V)	50/60	6.5	1.5	16	B
20-1/1 G (2 AC 230 V)	50/60	5.7	1.3	16	B
20-2/1 G (2 AC 230 V)	50/60	9.6	2.2	16	B

	Hz	Current consumption (A)	Power (kW)	Fuse (A)	RCD type
6-1/1 G (2 AC 240 V)	50/60	2.5	0.6	15	B
6-2/1 G (2 AC 240 V)	50/60	3.8	0.9	15	B
10-1/1 G (2 AC 240 V)	50/60	3.8	0.9	15	B
10-2/1 G (2 AC 240 V)	50/60	6.3	1.5	15	B
20-1/1 G (2 AC 240 V)	50/60	5.4	1.3	15	B
20-2/1 G (2 AC 240 V)	50/60	9.2	2.2	15	B

	Hz	Current consumption (A)	Power (kW)	Fuse (A)	RCD type
6-1/1 G (1 ph 120 V)	60	5.0	0.6	15	F/B
10-1/1 G (1 ph 120 V)	60	7.5	0.9	15	B
20-1/1 G (1 ph 120 V)	60	10.8	1.3	15	F/B

	Hz	Current consumption (A)	Power (kW)	Fuse (A)	RCD type
6-1/1 G (1 ph 208 V)	60	2.9	0.6	15	B
6-2/1 G (1 ph 208 V)	60	4.3	0.9	15	B
10-1/1 G (1 ph 208 V)	60	4.3	0.9	15	B
10-2/1 G (1 ph 208 V)	60	7.2	1.5	15	B
20-1/1 G (1 ph 208 V)	60	6.3	1.3	15	B
20-2/1 G (1 ph 208 V)	60	10.6	2.2	15	B

	Hz	Current consumption (A)	Power (kW)	Fuse (A)	RCD type
6-1/1 G (1 ph 240 V)	50/60	2.5	0.6	15	B
6-2/1 G (1 ph 240 V)	50/60	3.8	0.9	15	B
10-1/1 G (1 ph 240 V)	50/60	3.8	0.9	15	B
10-2/1 G (1 ph 240 V)	50/60	6.3	1.5	15	B
20-1/1 G (1 ph 240 V)	50/60	5.4	1.3	15	B
20-2/1 G (1 ph 240 V)	50/60	9.2	2.2	15	B

7 Network connection

*this section does not apply to the USA and Canada.

7.1 Notes on network connection

The network connection allows you to connect the unit to your network, in order to connect the unit to ConnectedCooking.

Ethernet connection (Local Area Network)

iCombi Pro:

- Units are equipped with an Ethernet connection as standard.
- For a network connection, use at least a CAT-5 Ethernet cable.
- For unit sizes 6-2/3 GN to 10-2/1 GN, the connection is located on the rear of the unit.
- For unit sizes 20-1/1 GN and 20-2/1 GN, the connection is located on the underside of the unit.
- A detailed description of the connection to the network can be found in the original operating instructions.

iCombi Classic:

Units can optionally be ordered or retrofitted with an Ethernet connection.

The retrofit kit is available under item number 87.02.032S.

WLAN (Wireless Local Area Network)

The built-in WLAN adapter is a market-dependent option that is not available in every country.

- The units from the iCombi Pro series are equipped with a WLAN adapter as standard.
- A WLAN adapter is optionally available for units from the iCombi Classic series.

7.2 Connecting the unit to the network

Connecting the Ethernet cable

1. Unscrew the LAN connection.
 2. Unscrew the cap.
 3. Remove the sealing plugs.
 4. Push the Ethernet cable through the union nut.
 5. Push the Ethernet cable through the rubber grommet.
 6. Insert the rubber grommet into the clamp ring.
 7. Plug the Ethernet cable into the socket.
 8. Screw in the connection.
 9. Tighten the cap.
- >> The Ethernet cable is connected.

8 Water connection

8.1 Regulations for water connection

NOTICE

Malfunction due to minimum conductivity not being met

Make sure that the minimum conductivity of the water is 50 $\mu\text{S}/\text{cm}$ [32 ppm TDS].

The unit complies with all current regulations.

Adhere to the country standards and regulations for a connection to the drinking water supply, such as for hygiene requirements.

Water hose

- Supply and use a separate water tap for each unit.
- Use a water hose at least meeting the requirements of IEC 61770, EN 61770, EN 13618 or of equivalent quality.
- Do not use any used water hoses.
- A water hose as per EN 61770 is available from the manufacturer under item number [2067.0709](#). The materials used in this connection hose meet KTW, WRAS and FDA requirements.
- For the USA and Canada an adapter is required on the water hose.

Drinking water protection

Drinking water protection in accordance with EN 1717 requirements is required for connection to the drinking water network.

- For unit size 6-2/3 GN from the iCombi Classic series, drinking water protection for material class 3 as per EN 1717 must be installed in the inlet pipe of the water tap for connection to the drinking water network, e.g. a CA system separator as per EN 14367. The CA system separator is included in the delivery in the Netherlands, in Switzerland and Japan. For other countries in Europe, the CA system separator is available under item number [50.01.820](#).
- All other units meet the requirements for drinking water protection pursuant to EN 1717 in as-delivered condition.
- In countries with special requirements for drinking water protection, a backflow preventer must be installed (article number [60.73.482](#)). This set is included in the scope of delivery in Germany, the Netherlands and Switzerland.
In Japan, the backflow preventer (article number [50.01.685](#)) is included. If a second water connection is used, this must also be equipped with a backflow preventer.

Water pressure

- The water pressure in the supply line is 1.5 - 6* bar (21 - 87 psi).

- A water pressure of 3 bar (43 psi) is recommended.

Flow rates required for each unit

Unit size	6-2/3	6-1/1	6-2/1	10-1/1	10-2/1	20-1/1	20-2/1
Max. flow rate [l/min]	5	12	12	12	12	12	12
Max. flow rate (gal/min)	1.32	3.17	3.17	3.17	3.17	3.17	3.17

United Kingdom only: Note on installation requirements (IRN) R160

To be performed by the installer:

An approved double check valve or another non-return valve that is just as effective must be mounted directly on the water tap at the connection point.

Only Australia:

The installation must be carried out using the Plumbing Code of Australia.

8.2 Connecting water inlet

The water inlet connection is on the rear or underside of the unit.

Unit size 6-2/3 GN



Unit size 6-1/1 GN to 10-2/1 GN



Unit size 20-1/1 GN, 20-2/1 GN



- ✓ The on-site water inlet is rinsed and ventilated.
- ✓ The water hose is rinsed.
- ✓ Safety units, such as check valves or CA system separators are installed in the feed line on the tap.
- ✓ Line for shared cold water connection: 3/4 inch
- ✓ Temperature cold water: max. 30 °C [86 °F]

- ✓ Water hardness: min. 5 °dH (90 ppm).
 - ✓ Conductivity: min. 50 µS
 - ✓ The chlorine level (Cl₂) is below 0.2 mg/l (0.2 ppm) and the chloride concentration (Cl⁻) is below 80 mg/l (80 ppm). If the values are higher, use a water filter. Note the information on selecting the water filter.
1. Connect the water hose to the water inlet of the unit.
 2. Open the water tap.
- >> The water inlet is connected.

Recommendation for CombiMaster Plus without Care

The manufacturer recommends a preventative inspection be conducted around 6 months after unit commissioning to ascertain the degree of limescale buildup in the steam generator. This inspection should be performed by a trained technician.

8.3 Notes on water treatment

If the water quality is inappropriate for the unit, then water treatment is required. Please note the following:

- Treated water with hardness below 5°dH may be aggressive and corrosive, and can shorten the lifespan of the unit. Do not use treated water with hardness below 5°dH.
- Observe all country-specific regulations regarding water and drain connections, especially those regarding installation of water tapping points.
- Contact the local water supply company to inquire about water chloride levels (Cl⁻), chlorine levels (Cl₂), conductivity and hardness.
- When connecting the iCombi Pro to water with less than 7 °dH: When the self-test begins, the system will prompt the user to indicate the hardness of the water the unit is connected to. In this case, select Water hardness below 7°dH.
- In most cases, water connections do not require additional filters or water treatment.
- If critical water conditions prevail, filtration and/or water treatment is required.

8.4 Selecting the water filter

If critical water conditions prevail, filtration and/or water treatment is required. Please note the following in relation to the selection:

(A) Fine filters

We recommend particle filters with fineness of 5 - 15 µm [0.0002 – 0.0006 inches] for filtering water contaminated with sand, iron particles or suspended particles.

(B) Activated charcoal filters

If water contains high levels of chlorine (Cl_2) over 0.2 mg/l (corresponds to 0.2 ppm), an upstream activated carbon filter must be installed. Information about the chlorine level (Cl_2) can be obtained from the local water supply company.

(C) Reverse osmosis system

If the chloride concentration (Cl^-) is above 80 mg/l [80 ppm], a reverse osmosis system must be installed, due to the risk of corrosion. Information about the chloride level (Cl^-) can be obtained from the local water supply company.

NOTICE

Malfunction due to minimum conductivity not being met

Make sure that the minimum conductivity of the water is 50 $\mu\text{S}/\text{cm}$ [32 ppm TDS].

(D) Water softening

iCombi Pro / iCombi Classic

When used according to instructions, iCombi Pro / iCombi Classic units remove the limescale themselves. Upstream water softening is not necessary.

CombiMaster Plus without Care

- Water softening is recommended for treating water if severe calcification occurs (without chloride contamination).
- Use a slightly acidic decarbonisation ion exchanger (H^+). Sodium ion exchangers (as are commonly found in dishwashers) are not recommended.
- Phosphate metering is not recommended due to its negative effects on the water system.

Notes on connecting the water filter

The diameter of the water hose must be at least 1/2 inch and to the water filter at least 3/4 inch.

When using a combination of filters, ensure filter sequence in direction of flow:

- (A)-(B)-(C)
- or
- (A)-(B)-(D)

9 Drain connection

9.1 Regulations for drain connection

General notes for all units

NOTICE

The drain pipe does not meet requirements

Use a drain pipe with a high temperature resistance, which corresponds at least to a type PP pipe. Do not use a hose.

NOTICE

Incorrect installation of drain pipe

Do not solvent weld or glue the drain pipe to the unit drain.
Do not connect the drain pipe using a reducer to the unit drain.

NOTICE

Never close or cover the safety overflow

Do not reduce the safety overflow in the cross section.
The safety overflow must always be accessible and free. This is used for ventilation and drainage as a drain.

NOTICE

Dirty and greasy waste water

Make sure that a grease trap is installed by the owner to clarify the waste water.

- The unit complies with all relevant regulations (SVGW, KIWA, KIWA UK).
- The average wastewater temperature is 60 °C [140 °F].
- When dimensioning the drain, ensure that the steam generator short-term pump-off rate is 0.5 l/s [0.13 gal/s].
- If floor drain has no odour lock, make sure a 20 mm [0.79 inch] free outlet section is in place.
- Each unit size can be connected to a wall drain or floor drain.

Requirements for unit size 6-2/3 GN

We recommend integrating a siphon into the drain connection in order to optimise energy consumption.

- Diameter of the unit drain: DN 40 mm [1.5 inches]
- The unit has a DN 40/50 unit drain. The unit drain DN 40/50 is also available separately from the manufacturer under item number [8720.1031](#).

- Each unit must have its own drain connection.

Requirements for unit sizes 6-1/1 GN to 20-2/1 GN

NOTICE

Unit overflowing through external siphon

The unit is already equipped with an integrated siphon. A second external siphon without aeration of the drain will cause the unit to overflow.

No external siphon may be connected to the drain connection without upstream aeration.

You must ensure that there is a free outlet section and vent for the drain connection.

- Diameter of the unit drain: DN 50 mm [2 inches]
- A connection set for the unit drain DN 40/50 is available from the manufacturer under item number [8720.1031](#).
- Tabletop units: Each unit must have its own drain connection.

Additional requirements for Combi-Duo

In addition to the requirements for individual units, please note the following for a Combi-Duo system:

- Each unit must have its own drain connection.
- For Combi-Duo with floor drain, no odour lock may be installed in the drain.

Options

- In order to reduce pressure in the drain pipe, install a riser in the drain pipe.
- Tabletop units: To increase ground clearance, a 110 mm [4.33 inches] unit elevation kit and a height-adjustable transport trolley for mobile oven racks are available.
- Standalone units: To increase ground clearance, a unit elevation kit and elevation kit for the mobile oven rack are available.

Additional requirements for the iCareSystem AutoDose option.

NOTICE

Dirty waste water contaminating the unit

The dirty waste water must not enter the unit or the drinking water network after cleaning.

- Do not install piping systems on the safety overflow.
- Do not combine the unit with other drain systems.

In addition to the requirements for tabletop units, note the following for the iCareSystem AutoDose (iCareSystem AutoDose ▶ 102) option:

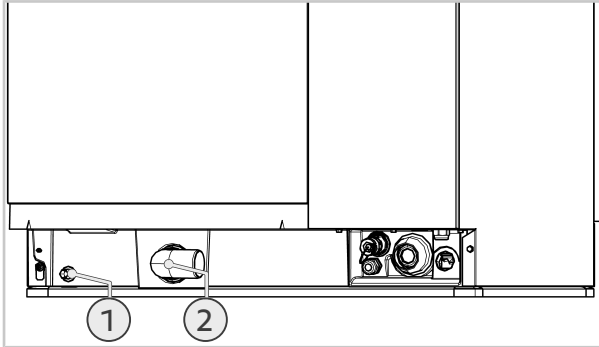

- The safety overflow (1) on the unit must always be clear.
- The safety overflow (1) must not be combined with waste water or drain systems.
- The wastewater connection (2) must not be combined with other wastewater systems.

9.2 Connect waste water drain

✓ The drain pipe is resistant to high temperatures.

1. Connect the drain pipe DN 50 mm [2 inch] (for unit size 6-2/3: DN 40 mm [1.5 inch]) with a constant gradient of at least 5 % or 3° (1/4 inch/foot). Use a 90° elbow as the first pipe section for the drain pipe.
2. Place the drain pipe to the side, straight or downwards.

Unit size 6-2/3 GN

International - exception: does not apply to the United Kingdom:

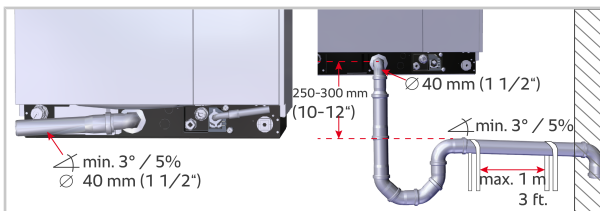

Only applies to the United Kingdom:

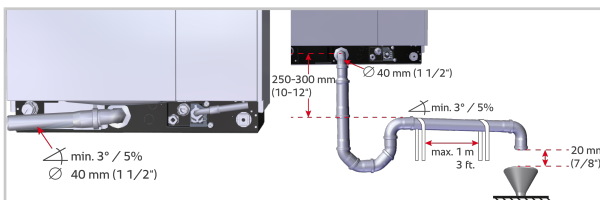

Unit sizes 6-1/1 GN to 10-2/1 GN

International - exception: does not apply to the United Kingdom:

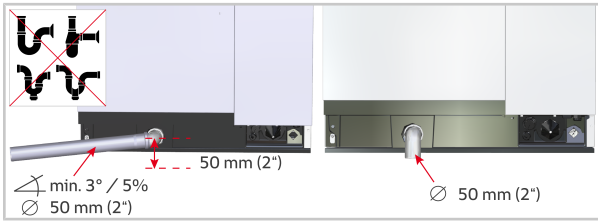

Only applies to the United Kingdom:

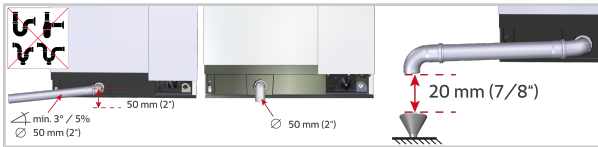

The average height of the waste water connection for tabletop units is around 50 mm [1.57 inches].

Unit size 20-1/1 GN, 20-2/1 GN

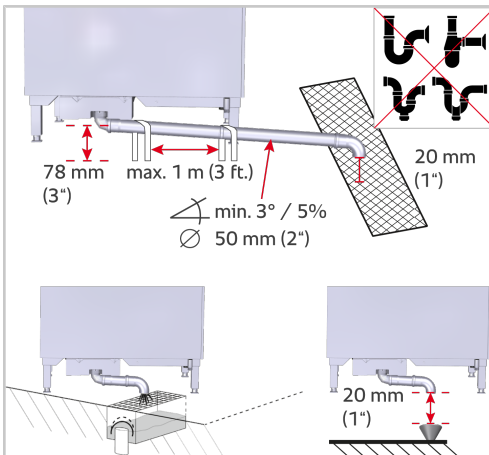

The average height of the 90-degree pipe at the drain connection is 78 mm [3 inches].

9.3 Additional aeration of the drain (optional)

NOTICE

Unit overflowing through external siphon

The unit is already equipped with an integrated siphon. A second external siphon without aeration of the drain will cause the unit to overflow.

No external siphon may be connected to the drain connection without upstream aeration.

You must ensure that there is a free outlet section and vent for the drain connection.

NOTICE

Regular cleaning of the funnel

The funnel on the vent pipe must be cleaned at regular intervals. The funnel must be removed from the vent pipe for cleaning.

NOTICE

Odour formation due to unnecessary ventilation section

If a vent pipe is installed for safety reasons due to an unknown wastewater section, an odour may form. This is the case if there is no external odour trap installed in the wall.

- The vent pipe is not necessary.
- Remove the ventilation section with the vent pipe.
- Connect the wastewater section according to the specifications.

If an external siphon is connected, the unit requires additional aeration of the drain via a vent pipe, which is connected to the drain pipe and prevents the unit from overflowing. This vent pipe is provided with holes in the lower area (1), in order to achieve a suction effect.

The vent pipe must be fitted with a funnel (item number: 60.76.798) (2). The funnel destroys the foam that is produced during cleaning and prevents the vent pipe from overflowing.

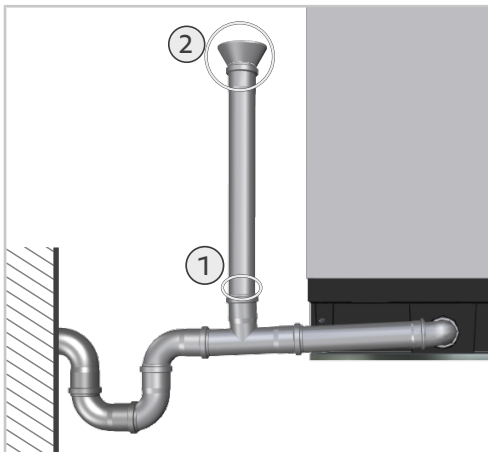

Cleaning the funnel

CAUTION

Risk of scalding when cleaning with liquid

There is a risk of scalding when cleaning with hot water.

- Carefully clean the funnel with hot water.
- Wear protective clothing when cleaning.

- ✓ The unit is switched off.
 - ✓ The funnel must be removed from the unit for cleaning.
1. Clean the funnel with hot water.
 2. Install the cleaned funnel on the vent pipe.
- >> The funnel is clean and installed. The unit can be put into operation again.

10 Gas connection for gas units

This section only applies to gas units.

DANGER

Fire due to incorrect gas connection

Danger to life due to fire from an incorrect gas connection.

- Follow local regulations of the gas supply company.
- Check the type of gas available and the dynamic connection pressure against the values specified on the unit.

DANGER

Risk of poisoning due to faulty gas connection

Risk of poisoning from CO and other toxic gas components

- Do not connect the units to networks containing carbon monoxide (CO) gases or other toxic components.

DANGER

Permissible CO/CO₂ values exceeded

Risk of poisoning due to excessive CO/CO₂ values because of incorrect burner settings.

- Always perform a flue gas analysis when commissioning gas units.
- Document the flue gas values.
- It is recommended that the installation site be equipped with a CO gas detector.

DANGER

Increased CO values due to wrong gas type

Risk of poisoning due to connection of wrong gas type

- Only connect the unit to the gas type stated on the unit type plate.
- Check the type of gas available and the dynamic connection pressure against the values specified on the unit.
- It is recommended that the installation site be equipped with a CO gas detector.

DANGER

Changes on components with sealing paint

Risk of injury and damage when changing components sealed with paint.

- Do not change components with sealing paint (exception: CO₂ screw).
- In the event of damage to the sealing paint, the affected components must be replaced before the unit is put into operation.

10.1 Regulations for gas connection

NOTICE

Connection flow pressure exceeded

A connection flow pressure above 65 mbar [0.94 psi] will lead to the unit malfunctioning and the gas components being damaged.

- Adhere to the maximum connection flow pressure for natural gas of 21 mbar [0.44 psi].
- For LPG, adhere to the maximum connection flow pressure of 37 mbar [0.84 psi].
- Adhere to the general maximum connection flow pressure of 65 mbar [0.94 psi].
- If the pressure is higher, block the gas supply to the unit and do not commission the unit.
- Only USA and Canada: National Fuel Gas Code, ANSI Z223.1/NFPA 54 and the Natural Gas and Propane Installation Code, CSA B149.1

Requirements for gas type and gas pressure

- Check that the factory gas setting on the unit corresponds to the actual local gas supply conditions.
- The gas type and the dynamic connection pressure set on the unit must correspond to those stated on the type plate.

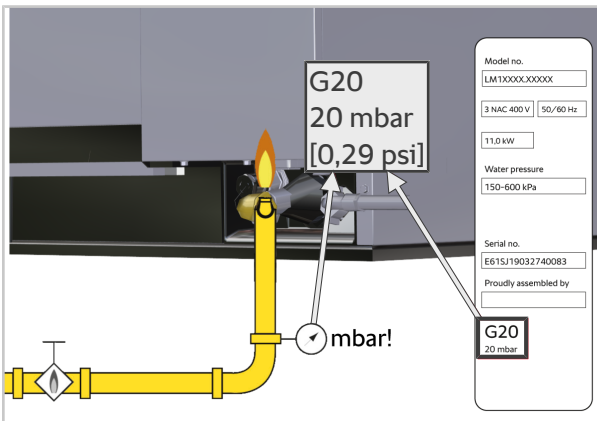

- If the line pressure deviates from the connection flow pressure of the unit, contact your gas supply company.

- Adhere to all local gas company regulations.

Requirements for gas inlet and gas line

- The exhaust gas analysis may only be carried out by a technician who is authorised by the manufacturer. The exhaust gas analysis must be carried out before commissioning.
- Gas connections must only be set up by locally authorised gas technicians.
- The gas connection line must be set up in accordance with the rated thermal load specified on the type plate.
- Use a suitable gas leak detector to check for leaks in the gas supply and gas distribution within the unit.
- The cross-section of the gas line must be designed to the maximum connected output of all loads, at least $\frac{3}{4}$ inch.
- A gas shut-off valve must be installed in front of every unit.
- All on-site connection parts must be tested in accordance with DIN-DVGW (the local regulations).
The hose for the gas connection must not be longer than 2.0 m [78 $\frac{3}{4}$ inch].
- It is possible to connect the gas line with a gas socket.
- A connection with the appropriate counterpart to the $\frac{3}{4}$ inch internal thread (RP thread) is required to connect the gas line.
- The unit must be protected against slipping.
- If undiluted CO levels are above 174.7 mg/m³ [150 ppm] for hot air mode and 465.8 mg/m³ [400 ppm] for steam mode, a company-trained and certified technician must be called in to check burner settings in accordance with setting instructions, and adjust these settings if needed. A flue gas analysis must then be performed by the technician.
- Follow the maintenance instructions for gas components.
- The gas installation must meet the CGA-B 149.1 natural gas regulation or the CGA-B 149.2 propane gas regulation.

Australian Supplement to Gas Installation

- To be installed only by authorised person in accordance with AS/NZS 5601, local authority, gas, electricity, any applicable statutory regulations and manufacturer requirements.
- Particular attention should be given to relevant requirements regarding ventilation.
- This unit is not suitable for use in marine environment.

10.2 Connecting the unit to the gas supply

- ✓ The gas connection is equipped with an internal thread (RP thread). A suitable counterpart meeting the standards is available.

10 | Gas connection for gas units

- ✓ An additional Teflon tape to seal in the thread is available. The sealing agent must comply with the locally approved regulations.
 - ✓ A gas shut-off valve is provided on-site.
 - ✓ The type of gas available and the dynamic connection pressure correspond to the values specified on the unit's type plate.
 - ✓ The unit is secured to prevent it from slipping.
 - ✓ The gas line is routed so that it cannot be kinked, turned or pulled. The gas line must be at a sufficient distance from heat sources.
1. Connect the gas pipe with the unit's gas connection.
 - > Make sure that the threads are screwed in far enough to ensure mechanical tightness and strength.
For this, refer to regional standards and ISO 7/1.
 2. Use a suitable gas leak detector to check for leaks in the gas supply and gas distribution within the unit.

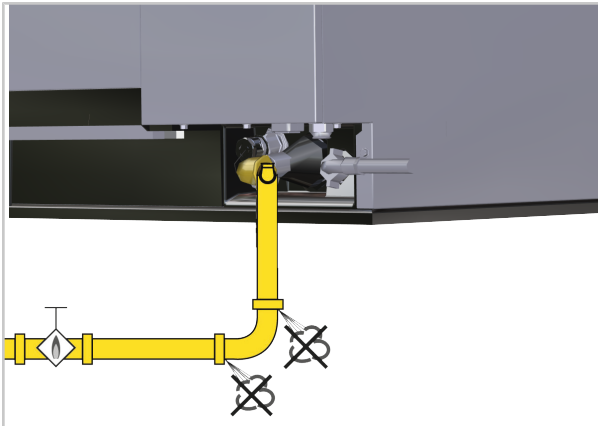

10.3 Gas consumption by gas type

Natural gas H G20

	6-1/1	6-2/1	10-1/1	10-2/1	20-1/1	20-2/1
Required connection flow pressure (mbar)	18-25	18-25	18-25	18-25	18-25	18-25
Wobbe index (MJ/m ³) Wi	45.67	45.67	45.67	45.67	45.67	45.67
Wobbe index (MJ/m ³) Ws	50.72	50.72	50.72	50.72	50.72	50.72
Max. Consumption at rated thermal load (at 15°C, 1013 mbar)	1.4 m ³ /h	3.05 m ³ /h	2.35 m ³ /h	4.23 m ³ /h	4.44 m ³ /h	8.47 m ³ /h

	6-1/1	6-2/1	10-1/1	10-2/1	20-1/1	20-2/1
Max. Consumption at rated thermal load (at 15°C, 1013 mbar)	13 kW	28 kW	22 kW	40 kW	42 kW	80 kW

Natural gas G20Y20

	6-1/1	6-2/1	10-1/1	10-2/1	20-1/1	20-2/1
Required connection flow pressure (mbar)	17-25	17-25	17-25	17-25	17-25	17-25
Wobbe index (MJ/m ³) Wi	43.24	43.24	43.24	43.24	43.24	43.24
Wobbe index (MJ/m ³) Ws	48.24	48.24	48.24	48.24	48.24	48.24
Max. Consumption at rated thermal load (at 15°C, 1013 mbar)	1.6 m ³ /h	3.45 m ³ /h	2.71 m ³ /h	4.92 m ³ /h	5.17 m ³ /h	9.48 m ³ /h
Max. Consumption at rated thermal load (at 15°C, 1013 mbar)	13 kW	28 kW	22 kW	40 kW	42 kW	80 kW

Natural gas L G25

	6-1/1	6-2/1	10-1/1	10-2/1	20-1/1	20-2/1
Required connection flow pressure (mbar)	20-30	20-30	20-30	20-30	20-30	20-30
Wobbe index (MJ/m ³) Wi	37.38	37.38	37.38	37.38	37.38	37.38
Wobbe index (MJ/m ³) Ws	41.52	41.52	41.52	41.52	41.52	41.52
Max. Consumption at rated thermal load (at 15°C, 1013 mbar)	1.60 m ³ /h	3.45 m ³ /h	2.71 m ³ /h	4.92 m ³ /h	5.17 m ³ /h	9.85 m ³ /h
Max. Consumption at rated thermal load (at 15°C, 1013 mbar)	13 kW	28 kW	22 kW	40 kW	42 kW	80 kW

LPG G30

	6-1/1	6-2/1	10-1/1	10-2/1	20-1/1	20-2/1
Required connection flow pressure (mbar)	25-57.5	25-57.5	25-57.5	25-57.5	25-57.5	25-57.5
Wobbe index (MJ/m ³) Wi	80.58	80.58	80.58	80.58	80.58	80.58
Wobbe index (MJ/m ³) Ws	87.33	87.33	87.33	87.33	87.33	87.33
Max. Consumption at rated thermal load (at 15°C, 1013 mbar)	1.06 kg/h	2.33 kg/h	1.81 kg/h	3.31 kg/h	3.47 kg/h	6.62 kg/h
Max. Consumption at rated thermal load (at 15°C, 1013 mbar)	13.5 kW	29.5 kW	23 kW	42 kW	44 kW	84 kW

LPG G31

	6-1/1	6-2/1	10-1/1	10-2/1	20-1/1	20-2/1
Required connection flow pressure (mbar)	25-57.5	25-57.5	25-57.5	25-57.5	25-57.5	25-57.5
Wobbe index (MJ/m ³) Wi	74.75	74.75	74.75	74.75	74.75	74.75
Wobbe index (MJ/m ³) Ws	81.19	81.19	81.19	81.19	81.19	81.19
Max. Consumption at rated thermal load (at 15°C, 1013 mbar)	1.01 kg/h	2.18 kg/h	1.71 kg/h	3.11 kg/h	3.26 kg/h	6.21 kg/h
Max. Consumption at rated thermal load (at 15°C, 1013 mbar)	13 kW	28 kW	22 kW	40 kW	42 kW	80 kW

LPG Australia

	6-1/1	6-2/1	10-1/1	10-2/1	20-1/1	20-2/1
Dynamic gas pressure (kPa)	2.75-3.5	2.75-3.5	2.75-3.5	2.75-3.5	2.75-3.5	2.75-3.5
Wobbe index (MJ/m ³) Wi	74.75	74.75	74.75	74.75	74.75	74.75

	6-1/1	6-2/1	10-1/1	10-2/1	20-1/1	20-2/1
Wobbe index (MJ/m ³) Ws	81.19	81.19	81.19	81.19	81.19	81.19
Max. Consumption at rated thermal load (at 15°C, 1013 mbar)	52 MJ/h	112 MJ/h	88 MJ/h	160 MJ/h	168 MJ/h	320 MJ/h

Natural Gas Australia

	6-1/1	6-2/1	10-1/1	10-2/1	20-1/1	20-2/1
Dynamic gas pressure (kPa)	1.13-2.5	1.13-2.5	1.13-2.5	1.13-2.5	1.13-2.5	1.13-2.5
Wobbe index (MJ/m ³) Wi	45.67	45.67	45.67	45.67	45.67	45.67
Wobbe index (MJ/m ³) Ws	50.72	50.72	50.72	50.72	50.72	50.72
Max. Consumption at rated thermal load (at 15°C, 1013 mbar)	52 MJ/h	112 MJ/h	88 MJ/h	160 MJ/h	168 MJ/h	320 MJ/h

Natural Gas 13A Japan

	6-1/1	6-2/1	10-1/1	10-2/1	20-1/1	20-2/1
Required connection flow pressure (mbar)	18-25	18-25	18-25	18-25	18-25	18-25
Wobbe index (MJ/m ³) Wi	55.3	55.3	55.3	55.3	55.3	55.3
Max. Consumption at rated thermal load (at 15°C, 1013 mbar)	13.7 kW	29.4 kW	23.1 kW	42 kW	44.1 kW	84 kW

Liquid Gas Japan

	6-1/1	6-2/1	10-1/1	10-2/1	20-1/1	20-2/1
Required connection flow pressure (mbar)	25-57.5	25-57.5	25-57.5	25-57.5	25-57.5	25-57.5
Wobbe index (MJ/m ³) Wi	74.75	74.75	74.75	74.75	74.75	74.75
Wobbe index (MJ/m ³) Ws	81.19	81.19	81.19	81.19	81.19	81.19
Max. Consumption at rated thermal load (at 15°C, 1013 mbar)	14.1 kW	30.4 kW	23.9 kW	43.5 kW	45.7 kW	87 kW

Natural Gas G20 USA

	6-1/1	6-2/1	10-1/1	10-2/1	20-1/1	20-2/1
Required connection flow pressure (mbar)	6.5-10.0 in/wc	6.5-10.0 in/wc	6.5-10.0 in/wc	6.5-10.0 in/wc	6.5-10.0 in/wc	6.5-10.0 in/wc
Wobbe index (MJ/m ³) Wi	45.67	45.67	45.67	45.67	45.67	45.67
Wobbe index (MJ/m ³) Ws	50.72	50.72	50.72	50.72	50.72	50.72
Max. Consumption at rated thermal load (at 15°C, 1013 mbar)	48.58 ft ³ /h	104.64 ft ³ /h	82.21 ft ³ /h	149.48 ft ³ /h	156.96 ft ³ /h	298.96 ft ³ /h
Max. Consumption at rated thermal load (at 15°C, 1013 mbar)	49500 BTU/hr	106500 BTU/hr	83500 BTU/hr	152000 BTU/hr	159500 BTU/hr	303500 BTU/hr

Propane Gas 3P G31 USA

	6-1/1	6-2/1	10-1/1	10-2/1	20-1/1	20-2/1
Required connection flow pressure (mbar)	10-15 in/wc	10-15 in/wc	10-15 in/wc	10-15 in/wc	10-15 in/wc	10-15 in/wc
Wobbe index (MJ/m ³) Wi	74.75	74.75	74.75	74.75	74.75	74.75
Wobbe index (MJ/m ³) Ws	81.19	81.19	81.19	81.19	81.19	81.19
Max. Consumption at rated thermal load (at 15°C, 1013 mbar)	2.23 lb/h	4.80 lb/h	3.77 lb/h	6.85 lb/h	7.19 lb/h	13.7 lb/h
Max. Consumption at rated thermal load (at 15°C, 1013 mbar)	48500 BTU/hr	104000 BTU/hr	82000 BTU/hr	148500 BTU/hr	156000 BTU/hr	296500 BTU/hr

11 Exhaust gas connection on gas units

This section only applies to gas units.

DANGER

Toxic flue gas

Risk of asphyxiation from unauthorised concentration of harmful flue gases.

- Ensure that the ventilation options in the installation area are adequate.
- Perform a flue gas analysis prior to commissioning the unit.
- Install the unit under a kitchen ventilation system.
- Only for Japan:
The unit must be installed under an extraction hood.

11.1 Regulations for exhaust gas connection

- The units are classified pursuant to DVGW G631 of 03/2012 as flue gas types A3 and B23, B13, B13BS. Adhere to the provisions for the relevant types.
- Observe instructions given in the currently valid versions of all local standards during installation.
- When using hydrogen (20%), set the flue gas value to O₂.
- The flue gas connection must meet the requirements of the NFPA 96.
- Follow the maintenance instructions for gas components.

Flue gas and room volumes

The following values only apply to the individual unit:

	6-1/1	6-2/1	10-1/1	10-2/1	20-1/1	20-2/1
Min. Room size with constant ventilation (m ³)	26	56	44	80	88	*
Min. Room size with free ventilation (m ³)	52	112	88	160	176	*
Min. Combustion air supply (m ³ /h)	21	45	35	64	70	128
Min. Combustion air supply (ft ³ /h)	742	1590	1236	2260	2472	4521
Max. Exhaust gas volumes (m ³ /h)	38	108	78	160	150	311
Max. Exhaust gas volumes (ft ³ /h)	1342	3814	2755	5651	5298	10983
Max. Exhaust gas temperature (°C)	350	520	470	590	430	520

	6-1/1	6-2/1	10-1/1	10-2/1	20-1/1	20-2/1
Max. Exhaust gas temperature (°F)	662	968	878	1094	806	968

*Combustion air supply from technical room ventilation systems

Combustion air supply

The combustion air supply is ensured by free ventilation or constant ventilation, one near the ceiling, one near the floor.

Free ventilation

Combustion air supply is assured through windows and doors.

Constant ventilation

The combustion air supply is ensured via two ventilation openings into the open air, each with a free cross-section of 150 cm² [23.25 in²] (one near the ceiling, one near the floor).

Technical room ventilation systems

Kitchens in which gas units with a total nominal heat load of more than 50 kW are installed must be ventilated and ventilated with HVAC systems. These air conditioning plants also secure combustion air supply for gas units if designed in accordance with VDI 2052.

11.2 Exhaust gas connection Type A3 and B23

Requirements for unit size 6-1/1 GN

- Type A3 exhaust air connection for this unit size corresponds to a room air-dependent gas furnace with fans in front of burners without flow guards and total rated load in installation space less than or equal to 14 kW.
If the total rated load is greater than 14 kW, the requirements for 6-2/1 - 20-2/1 GN also apply to the unit size 6-1/1 (see Exhaust gas connection Type A3 and B23 [▶ 93]).

- A clearance of 400 mm [15.75 inches] must be kept between the flue pipes of the unit and the fat filters of the exhaust hood/ventilation ceiling in order to prevent a risk of fire in the fat filter.

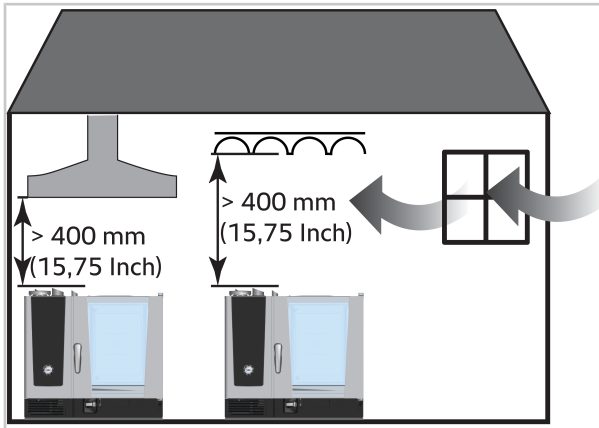

- It is not mandatory, but is recommended by the manufacturer, that the gas supply to the burners is only released when the extraction system is in operation.
- Updraft line are not required.
- For the installation of gas units with a type A flue gas connection with a total rated load of less than or equal to 14 kW, it is sufficient if the installation site meets one of the following criteria:
 - The installation site has a capacity of more than $2\text{m}^3/\text{kW}$ [$70.63\text{ ft}^3/\text{kW}$].
 - The installation site has a door or window to the outside that can be opened.
 - The kitchen ventilation system in use has a minimum extraction volume of $15\text{m}^3/\text{h}$ [$529.72\text{ ft}^3/\text{h}$] per kW total rated load and corresponding ventilation openings.

Requirements for unit sizes 6-2/1 GN to 20-2/1 GN

- Type B23 exhaust air connection for these unit sizes corresponds to a room air-dependent gas furnace with fans in front of burners without flow guards and total rated load in installation space greater than 14 kW.

- A clearance of 400 mm [15.75 inches] must be kept between the flue pipes of the unit and the fat filters of the exhaust hood/ventilation ceiling in order to prevent a risk of fire in the fat filter.

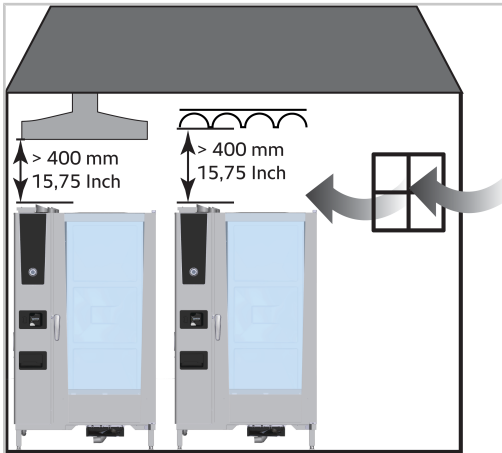

- Updraft line are not required.
- The unit must be placed directly under a kitchen ventilation system. The flue gas from the gas units with type A flue gas connection is first discharged into the room, flows directly into the kitchen ventilation system and is quickly discharged into the open air.
- Monitor the exhaust vent to ensure that gas is only fed to the burners when extraction is ensured.

11.3 Type B13 exhaust gas connection

CAUTION

Incorrect function of the units when installed with non-original exhaust gas collector with and without flow guard

Installing units with a non-original exhaust gas collector or exhaust gas collector with flow guard may damage the unit.

- Only use original exhaust gas collectors or exhaust gas collectors with flow guards from the manufacturer for installation.

Requirements

- The flue gas connection type B13 corresponds to a room air-dependent gas fireplace with fan upstream of the burners with exhaust gas collector.

- A clearance of 400 mm [15.75 inches] must be kept between the flue pipes of the unit and the fat filters of the exhaust hood/ventilation ceiling in order to prevent a risk of fire in the fat filter.

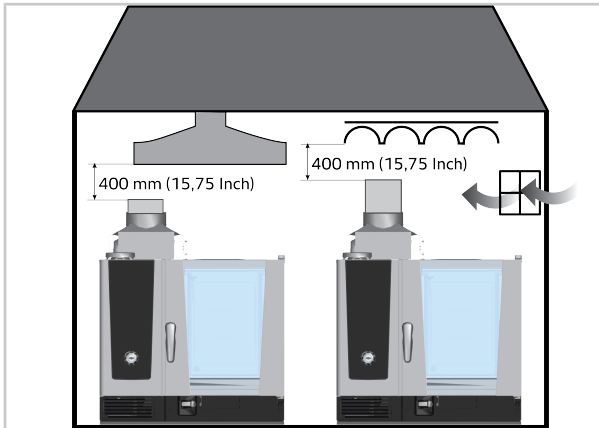

- Please note that for flue gas connection type B13 there must be a vertical upflow section.
- The upflow section must end 400 mm [15.75 inches] beneath the fat filter. The unit must be installed underneath an exhaust hood or a ventilation ceiling.
- Monitor the exhaust vent to ensure that gas is only fed to the burners when extraction is ensured.

11.4 Type B13BS exhaust gas connection

⚠ CAUTION

Incorrect function of the units when installed with non-original exhaust gas collector with and without flow guard

Installing units with a non-original exhaust gas collector or exhaust gas collector with flow guard may damage the unit. With B13BS, the safety function is not available. Frequent, undesired false alarms may occur.

- Only use original exhaust gas collectors or exhaust gas collectors with flow guards from the manufacturer for installation.

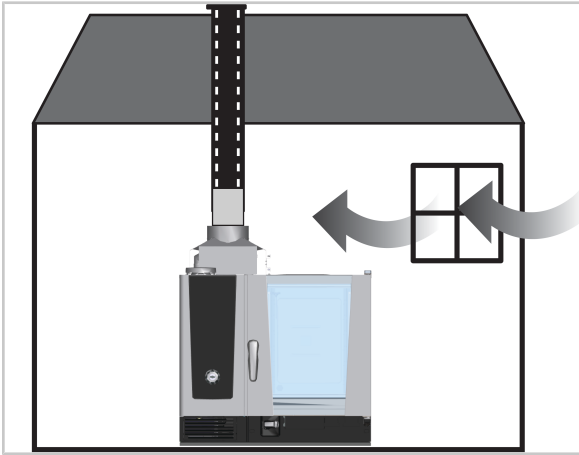

Requirements

For a type B13BS, a permanent connection to a chimney is permitted if a flow guard is also in use.

Contact the local master chimney sweep or an authorised authority for assistance in calculating the intake and exhaust air required.

11.5 Exhaust gas collector with and without flow guard for B13 and B13BS

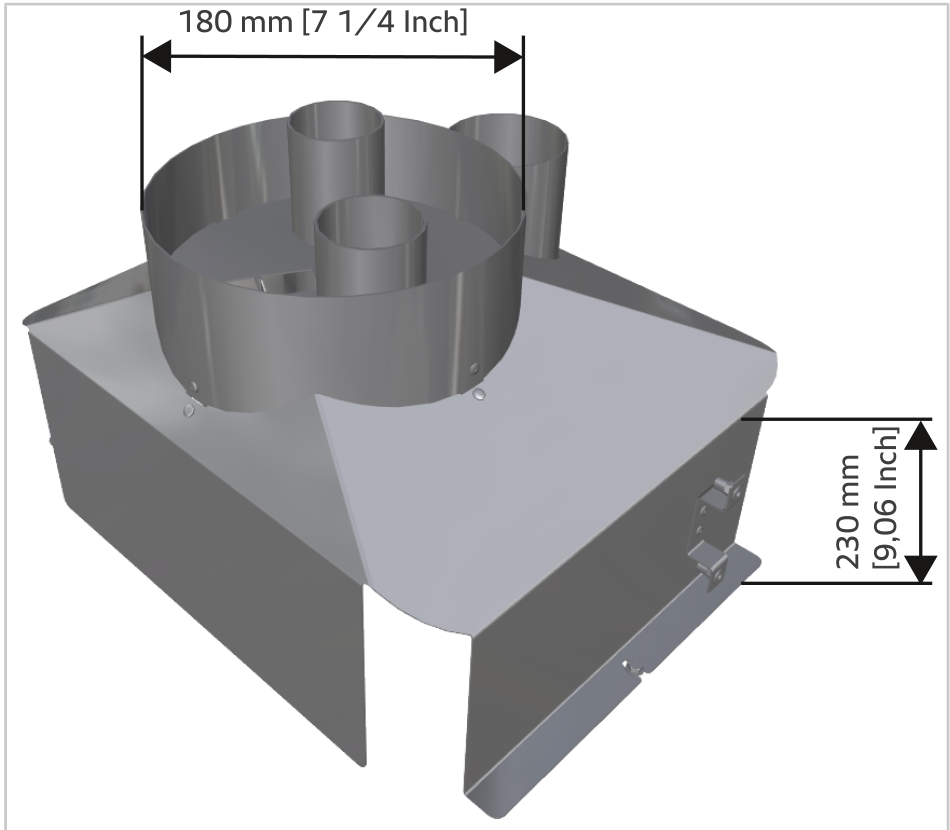

The exhaust gas collector with and without flow guard is not included in the scope of delivery of the unit, but can be ordered under the following item numbers:

Flue gas collector	6-1/1	6-2/1	10-1/1	10-2/1	20-1/1	20-2/1
Exhaust gas collector without flow guard B13	70.01.360	70.01.432	70.01.376	70.01.586	70.01.587	70.01.493
Exhaust gas collector with flow guard B13BS	70.01.339	70.01.431	70.01.340	70.01.582	70.01.583	70.01.492

The installation manual is enclosed with the exhaust gas collector with and without flow guard.

Notes on the exhaust gas system

NOTICE

Temperature-resistant exhaust gas pipes for high exhaust gas temperatures

The exhaust gas pipes must be temperature-resistant to 400°C [752°F].

Due to high exhaust gas temperatures, do not use exhaust pipes made of aluminium or of any materials that are not temperature-resistant up to 400°C [752°F].

Flue pipes must be sealed and installed in accordance with local standards. Continuous suction must be ensured. In the event of back pressure, the safety temperature limiter in the flow guard triggers. The safety temperature limiter is set to 103 °C [217.4°F].

12 Initial start-up

WARNING

Risk of scalding from hot steam

Hot steam is emitted during operation and when cleaning the unit. You could scald yourself on the hot steam when opening the cooking cabinet door.

- Open the cooking cabinet door carefully and leave the cooking cabinet door ajar for a few seconds so that the steam can escape upwards.
- Make sure that there is nobody standing in the area where steam is escaping.

12.1 Prior to commissioning

Removing shipping materials from the cooking cabinet

CAUTION

Flammable materials and objects in the cooking cabinet

Risk of fire due to packaging and transportation materials and starter kit in the cooking cabinet.

Remove all flammable materials and objects from the cooking cabinet prior to the initial commissioning.

Starter kit

The unit includes a starter kit which varies according to the scope of the order. Remove the starter kit from the cooking cabinet.

Maximum rack height

WARNING

Risk of scalding due to liquids

To avoid scalding, when working with liquids or foods that become liquid when heated, only use containers that are easy to monitor.

After installing the unit, affix the sticker indicating the maximum rack height at a height of 1600 mm [63 inches] to the unit. The sticker is provided in the starter kit.

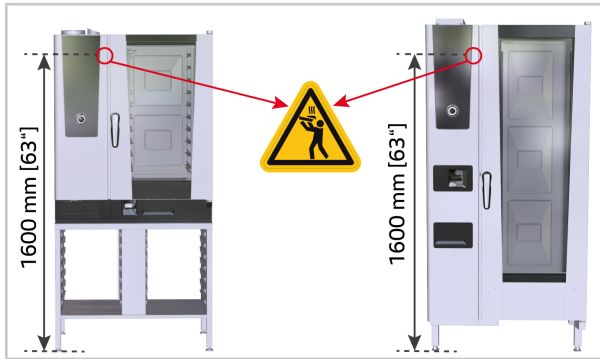

Perform software update

NOTICE

Perform software update

Always conduct a software update for commissioning. Your unit will then start up with the latest software version.

12.2 Perform the self-test

DANGER

Changed CO / CO₂ values after the self-test

Risk of poisoning due to excessive exhaust gas values.

- Conduct a flue gas analysis after the selftest.
- Set the values pursuant to the flue gas analysis provisions.

When first commissioning the unit, the selftest must be started once. During the selftest, the unit adapts to the ambient conditions.

The selftest runs automatically. The duration depends on the unit size and is between 45 and 65 minutes. With an UltraVent extraction hood, the self-test is extended by approx. 20 minutes.

Preparations

- The unit must be properly connected to water, waste water, and electricity as described in this manual; gas models must also be connected to gas supply and flue exhaust lines.
- Check the side racks and the air baffle to ensure they are seated correctly.
- The left side panel is closed.
- For the selftest, one GN container is required per fan wheel.

Insert the GN container

1. Insert one flat GN container in front of each fan wheel into the middle of the hook ladders, with the opening facing the bottom.
 - >> For unit sizes 6-2/3 GN to 6-2/1 GN, there is a GN container in the middle of the rack rails in front of the fan wheel.
 - >> For unit sizes 10-1/1 GN and 10-2/1 GN, there are two GN containers in the rack rails, one in the middle of each fan wheel.
 - >> For unit sizes 20-1/1 GN and 20-2/1 GN, there are three GN containers in the support rack trolley, one in the middle of each fan wheel.



Start self-test

1. Close the cooking cabinet door.
2. Start the selftest.
 - >> The selftest will check whether the unit is sealed. If steam emerges from the closed cooking cabinet door during the self-test, wait until the self-test is completed and then check the door setting.
 - >> The display will indicate when the selftest is complete.

NOTICE

If steam escapes from the door during the selftest, the door setting may be incorrect. In this case, check the door setting and reset the door if necessary.

12.3 Sodium hydroxide free cleaner

In order to achieve an optimal cleaning result with the sodium hydroxide-free cleaner (NaOH-free cleaner), the use of the sodium hydroxide-free cleaner must be activated in the operator menu.

Activation adjusts the required quantity of cleaner.

For units with the iCareSystem AutoDose option, service messages may also occur if the NaOH-free cleaner is used without it being activated in the operator menu.

Activate sodium hydroxide free cleaner

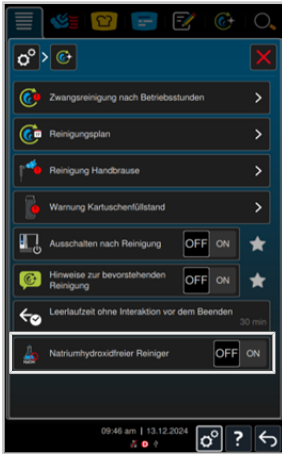

1. Select Settings in the operator menu.
 2. Select the menu item Cleaning.
 3. Activate sodium-hydroxide-free cleaner
- >> The sodium hydroxide-free cleaner can now be used.

12.4 iCareSystem AutoDose

*Only iCombi Pro, when ordering the option iCareSystem AutoDose. The option must be ordered separately and is available for unit size 6-1/1 - 10-2/1. The option is not retrofittable.

Observe the regulations for the drain connection in the chapter Drain connection (Regulations for drain connection [▶ 78]).

WARNING

Risk of chemical burns due to cleaning chemicals

There is a risk of chemical burns from conscious and unconscious contact with cleaning chemicals.

- During installation and maintenance, wear tight-fitting safety glasses and chemical protective gloves that will allow you to handle cleaning products safely.

NOTICE

Risk of damage due to spraying water

Cleaning with water jets can damage the iCareSystem AutoDose.

- Never use mechanical cleaning equipment to clean the iCareSystem AutoDose.

- Clean the iCareSystem AutoDose according to the specifications in the original operating instructions.

Inserting cartridges

- ✓ The unit is connected according to the regional specifications described in this installation manual.
 - ✓ The cooking cabinet door is open.
 - ✓ The cleaner and care cartridges are open.
1. Open the cover flap for the iCareSystem AutoDose.
Carefully fold down the cover flap underneath the cooking cabinet.

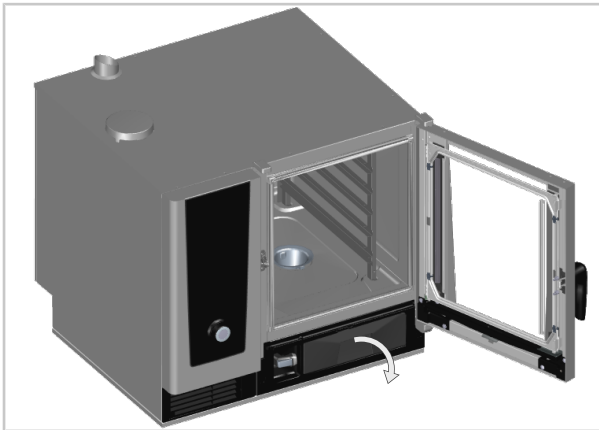

2. Insert the cartridges into the holder.
Insert the cartridge into the holder with the label facing upwards.
Press the cartridge into the holder until you feel it click into place.

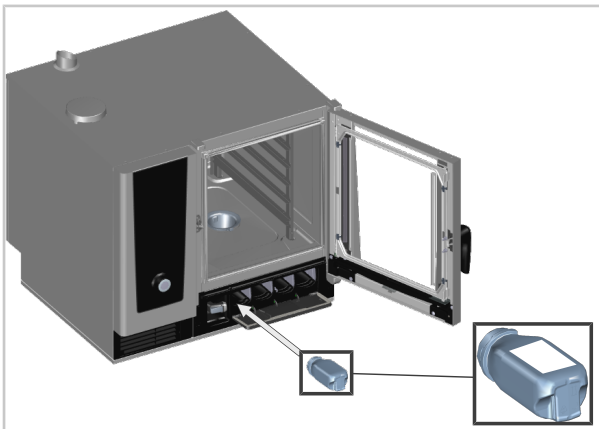

- > Insert cleaner and care cartridges. A total of four cartridges can be inserted. It can also be operated with fewer cartridges.

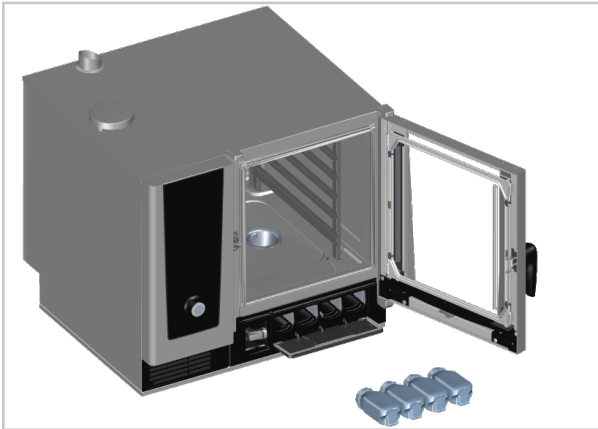

- > You do not need to follow any order when inserting the cartridges.

3. Close the cover flap for the iCareSystem AutoDose.

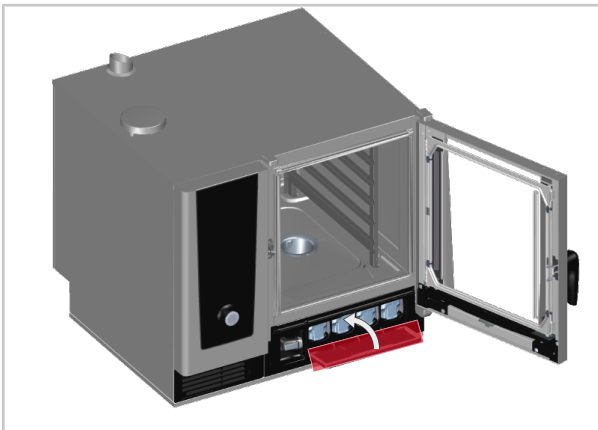

- > Cleaning will not start if the cover flap is not closed correctly.

>> The cartridges with the cleaning chemicals have been successfully inserted.

13 Maintenance

13.1 Maintenance notice

Notes for gas units

- In accordance with the specified standards, gas components must undergo annual maintenance.
- If maintenance and repair works have been performed on gas units, please note the following:
 - Check that the compensation tube is positioned correctly.
 - Check the gas supply line components for leaks.
 - Perform a flue gas analysis.

13.2 Replacing air filter

If the air filter is dirty, the unit will display a service prompt instructing you to replace the air filter.

Notes for the replacement of the air filter

Air filters may be replaced by the end user. When replacing it, ensure that the new air filter is carefully locked in the right position. Follow the instructions in the original operating instructions in the Maintenance chapter.

Air filter article numbers

Unit size	6-2/3	6-1/1 - 10-2/1	20-1/1 - 20-2/1
Air filter article number	40.04.771	40.05.424	40.05.654

14 Decommissioning

14.1 Notes on decommissioning

Note the following information on decommissioning the unit:

- Make sure the unit is cooled to below 40°C [104°F].
- Ensure that the steam generator is pumped dry.
- Make sure the cleaning box is pumped.
- Switch off the gas inlet.
- Make sure that the unit is disconnected from the power supply.
- Remove all water, waste water, and for gas units, also gas connections from the unit.
- If the unit is to be transported, remove the unit from the floor fixings and from any wall brackets (fastening chain).

Option iCareSystem AutoDose

- Make sure that the mixing box for the iCareSystem AutoDose is pumped empty.
- Remove the cartridges from the unit. These can be closed and reused.

14.2 Disposal

Electrical and electronic units such as the iCombi Pro and iCombi Classic must be disposed of separately.

- Do not dispose of the unit with the household waste and should not be disposed of at a municipal collection point for waste or used electrical units.
- The unit disposal regulations of each country must be observed.
- If required, contact the manufacturer for further information on disposal.

RATIONAL AG

Siegfried-Meister-Straße 1

86899 Landsberg am Lech, Germany

Tel. +49 (0)8191 3270

Fax +49 (0)8191 21735

info@rational-online.com

rational-online.com