

INSTALLATION AND OPERATING INSTRUCTIONS

Heat Pump Pool & Spa Heater



Professional Series
PS10353ti-E-HC
PS10354ti-E-HC
PS10355ti-E-HC



FOR YOUR SAFETY: Do not store or use gasoline or other flammable vapors and liquids or other combustible materials in the vicinity of this or any other appliance. To do so may result in an explosion or fire.

NOTE: The instructions in this manual are for the use of qualified individuals specially trained and experienced in the installation and maintenance of this type of equipment and related system components. Installation and service personnel are required by some states to be licensed. Persons not qualified shall not attempt to install, service, or maintain this equipment.

This manual should be maintained in legible condition and kept adjacent to the heater or in a safe place for future use.

Raypak[®]
A Rheem[®] Company

Effective: 11-15-23
Replaces: 04-01-22
P/N 241460 Rev. 5

Revision 5 reflects the following changes:

Updated cover page photo and Figure 4 for latest temperature control. Added new IPL item "11-H" Bypass Check Valve (PN: 100-10001222). Item "8-C" (3/8" Thermistor) and "11-C" (Coil Defrost Sensor) were removed from IPL. Item 6-H Contactor, 1 Phase (H000014) removed from the 9353 Unit in IPL; Item 6-H, 3 Phase (H000110) removed from the 9350 Unit in IPL. Item 3-J Contactor, 1 Phase (H000043) removed from the 9353 Unit in IPL; Item 3-J, 3 Phase (H000114) removed from the 9350 Unit in IPL. Item 5-J Monitor, 1 Phase (H000291) removed from the 9353. Item 6-J Control Board, PN: H000302 changed to PN: 100-10000347 for sizes 9350 & 9353; PN: H000302 changed to PN: 100-10000347 for sizes 10353, 10354 & 10355. Removed Item 8-J (LCD Display) from IPL.

TABLE OF CONTENTS

1. WARNINGS	4	15. MAINTENANCE	10
Pay Attention to these Terms	4	Air Coil Cleaning	10
2. WATER CHEMISTRY	5	Cabinet Care (optional)	11
3. INTRODUCTION	5	Unplug Condensation Drain Holes.....	11
4. INSTALLATION CONSIDERATIONS	5	16. TROUBLESHOOTING	11
5. ELECTRICAL CONNECTIONS	8	17. SERVICE CALL VERIFICATION	12
6. WATER CONNECTIONS	8	Power Supply	12
7. PRESSURE DROP	8	Water Flow	12
8. CONTROLS	9	Time Clock Adjustment	12
9. OPERATING INSTRUCTIONS	9	18. PLUMBING DIAGRAMS	13
Selecting Pool or Spa Mode.....	9	19. WIRING DIAGRAMS	17
Increasing Water Temperature (Pool-Spa Mode)....	9	208V/230V 3Ph, 60Hz Models	17
Reducing Water Temperature (Pool-Spa Mode).....	9	460V 3Ph, 60 Hz Models	18
Selecting Temperature (°C or °F).....	9	380V 3Ph, 60 Hz Models	19
10. HEAT/COOL OPERATION	9	20. INSTALLING REMOTE CONTROL DEVICE	20
11. SYSTEM START-UP	10	Wiring	20
12. SEASONAL STARTUP OR ANNUAL CHECK ..	10	Heater Settings	20
13. SUMMER SHUTDOWN	10	21. ILLUSTRATED PARTS LIST	21
14. FREEZE PROTECTION	10		
System Drain-Down	10		
Continuous Pump Operation	10		

1. WARNINGS

Pay Attention to these Terms

▲ DANGER	Indicates the presence of immediate hazards which will cause severe personal injury, death or substantial property damage if ignored.
▲ WARNING	Indicates the presence of hazards or unsafe practices which could cause severe personal injury, death or substantial property damage if ignored.
▲ CAUTION	Indicates the presence of hazards or unsafe practices which could cause minor personal injury or product or property damage if ignored.
CAUTION	CAUTION used without the warning alert symbol indicates a potentially hazardous condition which could cause minor personal injury or product or property damage if ignored.
NOTE	Indicates special instructions on installation, operation, or maintenance which are important but not related to personal injury hazards.

This manual, as well as the heater itself, contains ANSI-approved product safety signs and labels. Please read these signs and labels, as they convey important safety information about hazards that may be potentially present in and around the heater.

▲ CAUTION: Elevated water temperature can be hazardous. The U.S. Consumer Product Safety Commission has these guidelines:

1. Spa water temperatures should never exceed 104°F (40°C). A temperature of 100°F (38°C) is considered safe for a healthy adult. Special caution is suggested for young children.
2. Drinking of alcoholic beverages before or during spa or hot tub use can cause drowsiness which could lead to unconsciousness and subsequently result in drowning.
3. Pregnant Women Beware! Soaking in water over 102°F (39°C) can cause fetal damage during the first three months of pregnancy resulting in the birth of a brain-damaged or deformed child. Pregnant women should stick to the 100°F (38°C) maximum rule.
4. Before entering the spa or hot tub, users should check the water temperature with an accurate thermometer; spa or hot tub thermostats may err in regulating water temperatures by as much as 4°F (2.2°C).
5. Persons with a medical history of heart disease, circulatory problems, diabetes, or blood pressure problems should obtain a physician's advice before using pools or hot tubs.
6. Persons taking medications which induce drowsiness, such as tranquilizers, antihistamines, or anticoagulants, should not use spas or hot tubs.

▲ CAUTION: Improper chemical content in a swimming pool or spa can damage the heater. DO NOT add pool chemicals to the skimmer. This will damage the heater and could void the heater warranty. ALWAYS follow the product manufacturer's directions when adding any chemicals to your pool.

▲ WARNING: These heat pump pool heaters are charged with R-410A refrigerant. Ensure that all service work is done with gauges and equipment suitable for R-410A.

2. WATER CHEMISTRY

(Corrosive water voids all warranties)

For your health and the protection of your pool equipment, it is essential that your water be chemically balanced. The following levels, see **Table A**, must be used as a guide for balanced water.

- Occasional chemical shock dosing of the pool or spa water should not damage the heater providing the water is balanced.

Recommended Level(s)	Fiberglass Pools	Fiberglass Spas	Other Pool & Spa Types
Water Temp. (Deg. F)	68 to 88	89 to 104	68 to 104
pH	7.3 to 7.4	7.3 to 7.4	7.6 to 7.8
Total Alkalinity (PPM)	120 to 150	120 to 150	80 to 120
Calcium Hardness (PPM)	200 to 300	150 to 200	200 to 400
Salt (PPM)	4500 MAXIMUM	4500 MAXIMUM	4500 MAXIMUM
Free Chlorine (PPM)*	2 to 3	2 to 3	2 to 3
Total Dissolved Solids (PPM)	3000 MAXIMUM**	3000 MAXIMUM**	3000 MAXIMUM**

*Free Chlorine MUST NOT EXCEED 5 PPM!

** In salt water chlorinated pools, the total TDS can be as high as 6000ppm

Table A. Water Chemistry

- Automatic chemical dosing devices and salt chlorinators are usually more efficient in heated water. Unless controlled, they can lead to excessive chlorine level which can damage your heater.
- Further advice should be obtained from your pool or spa builder, accredited pool shop, or chemical supplier for the correct levels for your water.

3. INTRODUCTION

⚠ WARNING: This heater is an electromechanical machine that incorporates a pressurized refrigerant gas in a sealed system. ONLY trained and qualified service personnel are authorized to install or service this equipment. Without proper training and knowledge of such equipment, any attempt to install or service the unit could result in serious injury or even death.

This manual contains important information on the use, maintenance and troubleshooting of your new heater. This unit must be properly installed, maintained and operated for optimal performance.

This heater is an extremely efficient, economical machine designed specifically for heating swimming pools. It is similar in design and operation to a typical residential air conditioning system. The unit employs a hermetic motor/compressor operating in a refrigeration cycle to extract heat from ambient air and deliver it to the circulating pool water.

All heat pump pool heaters have a lower BTU/hr heating capacity than a gas-fired or oil-fired heater for the same pool and will have to operate more hours per day to keep the pool at setpoint. It may operate up to 24-hours a day at certain times. It is designed to do so. Even with long run-time hours, it will heat the pool at less cost than other heaters using fossil fuel.

Since evaporation is the main cause of heat loss from a pool, keeping the pool covered whenever it is not in use will

greatly reduce the cost of keeping the pool heated. Even during warmer weather, Raypak recommends keeping the pool covered at night.

4. INSTALLATION CONSIDERATIONS

⚠ WARNING: Do not install the unit within 3 ft (91 cm) of fossil-fuel-burning heaters. Air intake along the sides of this heat pump pool heater could disturb the combustion process of the unit, and could cause damage or personal injury.

- Mount the unit on a level, sturdy base, preferably a concrete slab or blocks. The size of the base should be at least 3 ft by 3 ft (91 cm by 91 cm).
- You must install the 4 black rubber sound isolation pads (each 2 inches square [5.1² cm]) that ship with the unit. The pads are shipped in a bag with the unions, gaskets and the installation manual. Install pads under the 4 corners of the unit to reduce vibration and sound transmission to the base.

⚠ CAUTION: The unit's supporting base must be high enough to keep it completely free of standing water at all times.

Situate the heater carefully to minimize installation costs while providing maximum efficiency of operation, and to allow adequate service access, as follows:

- For unrestricted air intake and service access, position each side of the unit at least 1 ft (30.5 cm) from walls, pipes and other obstructions.

⚠ WARNING: This unit is designed for outdoor installation. It is NOT certified for indoor installation. DO NOT install it in an enclosed area such as a shed or garage, or under a porch or deck.

- Recirculation of cold discharge air back into the evaporator coil will greatly reduce the unit's heating capacity and efficiency.
- This unit features an 'up-flow' discharge for quiet operation. Air is pulled up through the evaporator coil and discharged through the top grill. Allow at least 5 ft (1.5 m) clearance above the unit for unrestricted air discharge. DO NOT install the unit under a porch or deck. Refer to **Figure 1** for installation clearances.
- To minimize water piping, locate the unit as close as possible to the existing pool pump and filter.
- If the location of the heater is below the water line of the pool, the water pressure switch might need to be adjusted or an external water flow switch might be needed.

- Irrigation water should be directed away from the heater, water spray can damage the heat pump pool heater.
- Rain water run off, the heater can withstand normal rain. Install rain gutters to prevent direct streams of rain water to the heater.
- It is important to keep the area next to the heater clear of shrubs, bushes and chemicals containers. They could prevent air from circulating fully through the heater, and will affect the operation of the heater or damage the heater.
- When installed in areas where freezing temperatures can be encountered, drain the water circuit to prevent possible freeze-up damage. See "Freeze Protection" on **page 10**.
- For high wind installation requirements, refer to **Figure 2**.

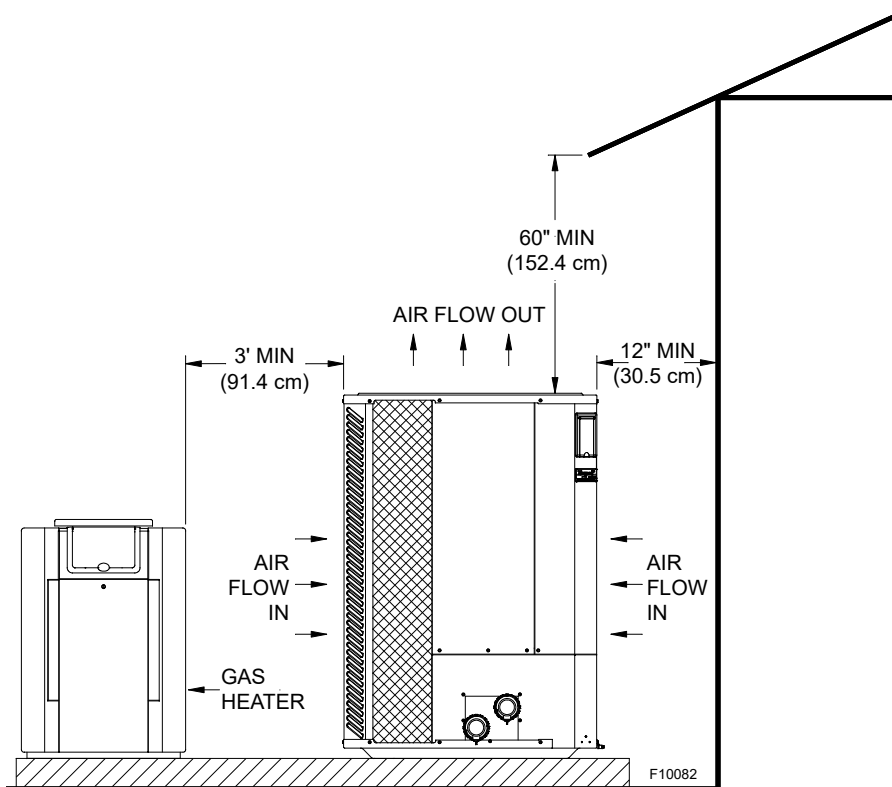

Figure 1. Installation Clearances

THIS DRAWING USED AS A GRAPHICAL REPRESENTATION ONLY AND IT
MAY NOT APPEAR EXACTLY LIKE YOUR SPECIFIC UNIT.

PAD SPECIFICATION

GREATER THAN OR EQUAL TO 4" (10 cm) THICK SOLID CONCRETE 3000 P.S.I. OR GREATER LOAD RATING
PAD LENGTH GREATER THAN OR EQUAL TO UNIT LENGTH +6" (+15.2 cm)
PAD WIDTH GREATER THAN OR EQUAL TO UNIT WIDTH +6" (+15.2 cm)

186 MPH (299 kph), 3 SEC. GUST IN ACCORDANCE WITH:

ASCE 7-2010 CHAPTER 30 WIND LOADS - COMPONENTS AND CLADDING
FLORIDA BUILDING CODE 2017 - SECTION 1609 WIND LOADS
FLORIDA BUILDING CODE 2017 - SECTION 1620 HIGH VELOCITY HURRICANE ZONES - WIND LOADS

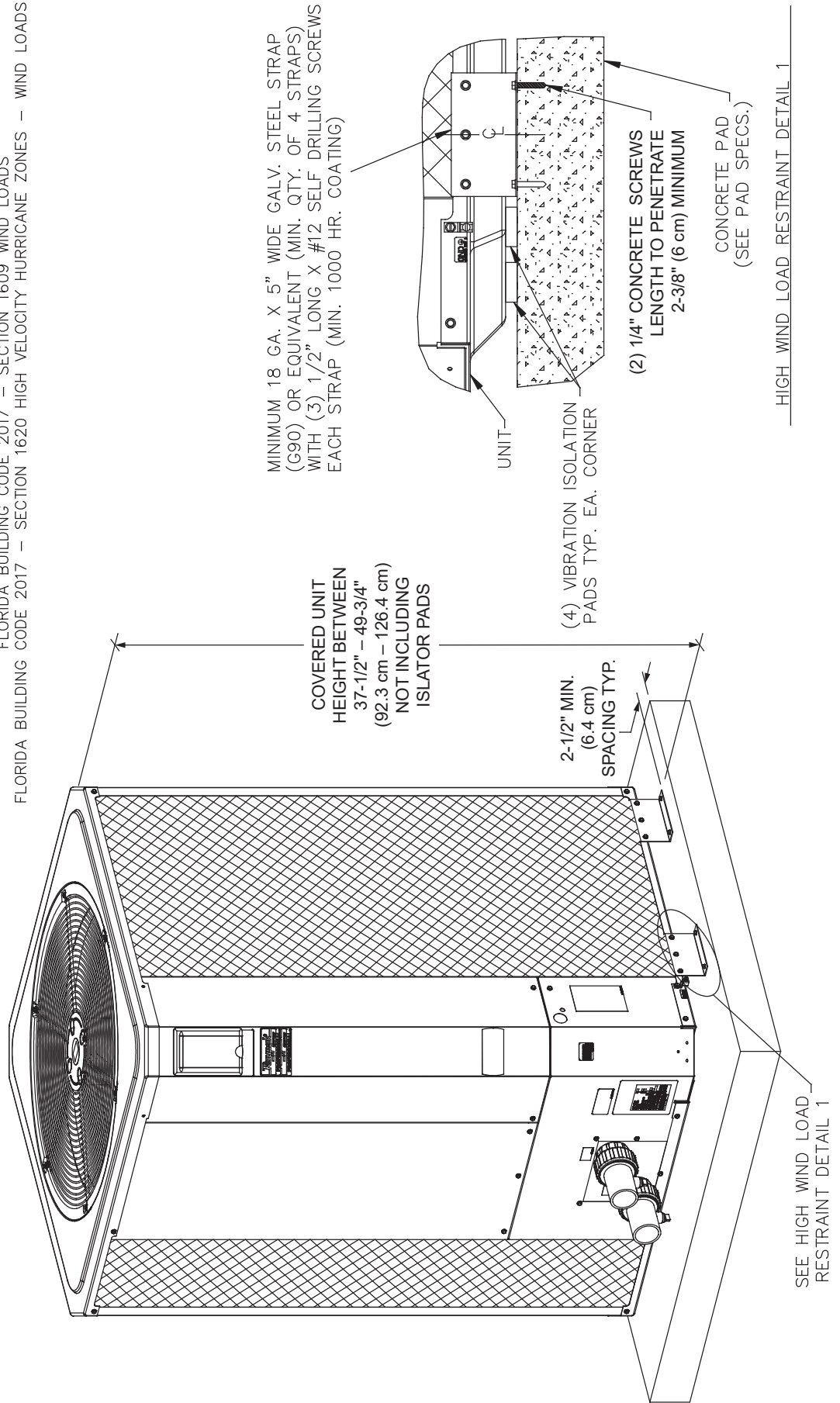

Figure 2. High Wind Installation Requirements

5. ELECTRICAL CONNECTIONS

Refer to the unit rating plate below the control panel for precise power requirements for your unit, and for ampacity and over-current protection requirements.

All wiring must be in accordance with the National Electrical Code, NFPA No. 70, latest edition, and all applicable state and local codes. See the wiring diagrams on **pages 17 through 19**.

NOTE: Refer to the National Electrical Code, Article 680, for general requirements for swimming pools and equipment, and to Article 440 for special considerations necessary for circuits supplying hermetic refrigeration motor/compressors.

- Locate the equipment disconnect means within 3 feet (91 cm) of the heater's electrical enclosure, or as close to the heater as possible. Always satisfy applicable codes and standards.
- In sizing power wiring, be especially aware of up-sizing requirements necessary due to wiring distances. Always satisfy applicable codes and standards.
- Electrical installation should be done by a licensed electrician only.

This unit is pre-wired to work with external control systems, heat-on-demand options and other external time clock overrides. Refer to the external control system's instructions, and "Installing a Remote Control Device" on **page 20** of this manual, for installation information.

Model No.	VAC Phase - Hz	Minimum Circuit Ampacity (A)	Maximum Breaker Size (A)
10353HC	208/230 - 3 - 60	42.0	70
10354HC	460 - 3 - 60	26.0	40
10355HC	380 - 3 - 60	29.0	45

Table B. Typical System Electrical Power Requirements

6. WATER CONNECTIONS

CAUTION: The heater inlet and outlet connections are NOT interchangeable. They must be connected as instructed below.

1. Connect the heater in the return water line between the filter and the pool/spa. See the Plumbing Diagrams beginning on **page 13**.
2. Connect the filter outlet to the fitting marked WATER IN at the bottom front of the unit.
3. Connect the fitting marked WATER OUT to the return piping to the pool/spa. Unit inlet/outlet connection fittings are 2-inch PVC unions.

Water connections from the unit to the main return line can be PVC pipe or flexible pipe approved for the purpose and, in either case, should be at least equal in size to the main pool/spa circulation piping.

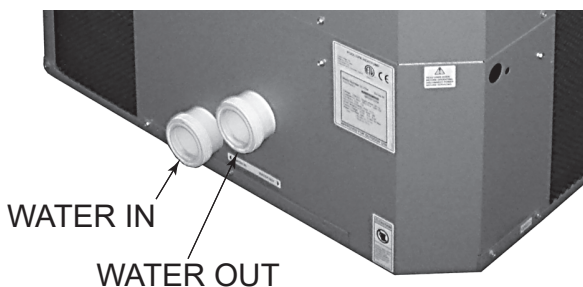

Figure 3. Water Connections

4. In cold weather (freeze zone) areas, shutoff valves (ball or gate type) must be installed at the unit inlet and outlet to facilitate service and cold weather drain-down.
5. Operate the pump and check the system for leaks.

7. PRESSURE DROP

For system pressure drop information, refer to **Table C** below.

Flow gpm (lpm)	Pressure Drop (psi)		
	10353HC	10354HC	10355HC
30 (114)	10	10	10
40 (151)	10	10	10
50 (189)	11	11	11
60 (227)	12	12	12

Multiply the pressure drop in psi by 2.3067 to yield the pressure drop in Ft. H₂O Head (TDH).

Table C. Pressure Drop Across Heater

WARNING: Install a check valve and/or a Hartford loop AFTER the heater and BEFORE any chlorinating devices. Install any automatic chemical feeders AFTER the heater. Improper installation of any type of automatic chemical feeders can result in serious damage to, or premature failure of, the heater. Such damage will not be covered under warranty.

8. CONTROLS

Your heater incorporates digital safety controls and indicators to ensure its safe, reliable operation.

Water Pressure Switch

It prevents operation when the pump is OFF. The unit requires 5 psi minimum pressure.

Digital Water Temperature Control

The pool water temperature is controlled by the heater's digital control system, which gives you the option of two settings: one for the desired spa temperature and the other for the desired pool temperature. Additionally, as mentioned earlier, the unit is compatible with most '2-wire' and '3-wire' control/automation systems.



Figure 4. Digital Water Temperature Control

Defrost Sensor

It prevents unit operation if ambient air temperature falls below a pre-determined safe minimum (approximately 42°–48°F (5.5°–8.8°C) based on humidity). The compressor will shut OFF but the fan will continue to run.

Delay Timer

It prevents compressor from short-cycling, which could damage or destroy the hermetic motor/compressor. Upon water temperature control satisfaction, or other circuit interruptions, this solid-state device will prevent compressor restart for approximately 5-minutes.

9. OPERATING INSTRUCTIONS

The electronic board has the capability of memorizing two different programmed temperature settings as follows (refer to **Figure 4**):

- For a pool, maximum 95°F (35°C)
- For a spa, maximum 104°F (40°C)

Selecting Pool or Spa Mode

To have access to either one of these programs, press the SET key until you see **P_S** and by pressing the UP or DOWN key you can switch to POL or SPA.

Increasing Water Temperature (Pool or Spa Mode)

Push the SET key until you see POL or SPA. The programmed temperature will be displayed. Press the UP arrow to increase the temperature setting one degree at a time.

Reducing Water Temperature (Pool or Spa Mode)

Push the SET key until you see POL or SPA. The programmed temperature will be displayed. Press the DOWN arrow to decrease the temperature setting one degree at a time.

Once the control has been programmed to the desired pool water temperature, the programmed temperature will be displayed for approximately 5-seconds. Then the digital display will display the actual pool water temperature.

To make the Board a Pool ONLY Board, call 800-260-2758 for instructions.

Selecting Temperature (°C or °F)

Press the SET key until you see **F_C**. By pressing the UP or DOWN key you can switch to °F or °C. Once the temperature display mode has been programmed it will be displayed for approximately 5-seconds, then the digital display will return to the actual pool water temperature in the mode that you have chosen.

10. HEAT/COOL OPERATION

The Raypak Professional models come standard with heat/cool operation. The heat/cool model is designed to both heat and cool the pool. To select heat or cool mode, push the SET key until H/C is displayed. Press the DOWN arrow key to select heating (HEA), or the UP arrow key to select cooling (COL). Set the desired setpoint temperature as described earlier in this manual.

NOTE: Once the control has been programmed to the desired pool water temperature, the programmed temperature will be displayed for approximately 5 seconds. The digital display will then show the actual pool water temperature.

NOTE: Remove the pool/spa blanket and turn on any fountains, sprays or other water features to speed cooling.

When the unit has been operating in the heating mode for a few minutes, the discharge air temperature should be 8°–10°F (4.5°–5.6°C) cooler than the air entering the unit.

When the unit has been operating in the cooling mode for a few minutes, the discharge air temperature should be 8°–10°F (4.5°–5.6°C) warmer than the air entering the unit.

NOTE: Heating is more efficient during warmer daylight hours and cooling is more efficient during cooler night time hours.

11. SYSTEM START-UP

Verify that the Digital Board is displaying a temperature and the pool pump is running and water is circulating properly.

Verify that the Board is programmed so that the desired temperature of the Pool and Spa is higher than the displayed current water temperature.

Allow the heater to operate for a few minutes to stabilize operating pressures and to allow various component temperatures to normalize.

Verify that the discharge air temperature is approximately 8°–10°F (4.5°–5.6°C) cooler than the air entering the unit. If not, see "Troubleshooting" on **page 11**.

12. SEASONAL START-UP OR ANNUAL CHECK

NOTE: At the beginning of the heating season, or whenever the pool water temperature is to be raised several degrees, the pool pump and heater may need to operate continuously for several days. During summer months, only a few hours per day may be necessary, or none at all.

1. Remove leaves, pine needles, etc., from the evaporator coil. Clean the coil by gently applying a mild solution of household liquid soap and water.
2. Gently rinse the coil with water; do NOT use high pressure.
3. Backwash or otherwise clean the pool filter. If necessary, clean the skimmer basket and pump strainer.

NOTE: If the pool pump and heater shut OFF before the water temperature is raised to the desired level, you must lengthen the running time of both. To do this, reset the time clock dial for the longer running time, or manually operate the pump with the timer over-ride switch. Since the heater capacity and efficiency are both greater at higher ambient air temperatures, run time should be set to take advantage of all daylight hours, when the air is generally warmer.

4. Set the valves to ensure proper water flow through the unit.

13. SUMMER SHUTDOWN

If you do not plan to use the heater during the summer months, secure and protect it as follows:

Turn the unit circuit breaker or disconnect switch to OFF.

During normal operation through the heating season, the valves need to be set at the normal position as mentioned in Step 4 (Section 12) for proper flow; don't readjust them.

During the summer shutdown period, the valves need to be reset to a position where most of the water bypasses the heater.

Be sure to reset the valves back to normal operating position at the beginning of the next heating season.

14. FREEZE PROTECTION

If the unit is installed in a location subject to freezing conditions, it is important to protect the water circuit from freezing, just as should be done for the pump and filter.

System Drain-Down

1. Turn the unit circuit breaker or disconnect switch to OFF.
2. With the pool pump OFF, close the external shutoff valves and loosen the inlet and outlet water unions to allow water to drain. Use a Wet/Dry Vac or air pressure to remove excess water.
3. Loosely re-attach the unions.
4. Cover the unit with a waterproof cover.

Continuous Pump Operation

It is also possible in some areas to prevent unit freeze damage by operating the pump continuously during freezing weather. However, this results in significantly higher pump operating costs. Further, if a sustained power failure occurs, the unit MUST be drained anyway, or freeze damage could result.

15. MAINTENANCE

NOTE: The heater MANUFACTURER IS NOT RESPONSIBLE for maintenance adjustments.

The following maintenance procedures are designed to keep your unit operating at a high level of reliability. Maintenance must be performed on a periodic basis to maintain warranty coverage and prevent system failures and performance degradation.

Air Coil Cleaning

Efficient operation depends on free circulation of air through the thin and tightly-spaced fins of the evaporator coil(s). The evaporator must be cleaned whenever it has a buildup of dirt or debris.

▲ CAUTION: To clean the fins, spray gently with a garden hose. DO NOT pressure wash. Doing so will bend the fins and such damage will not be covered under warranty.

Cabinet Care (optional)

The stainless steel cabinet is designed for harsh outdoor use and requires little care. However, you can clean it if you wish.

▲ WARNING: Shut OFF electricity to the unit before cleaning.

Wash the cabinet with soap and water.

Unplug Condensation Drain Holes

The unit extracts humidity from the air as it passes through the coil, similar to the way a cold drink outside “sweats” on a hot day. This condensation drains from the bottom of the unit.

1. Routinely check to be sure the condensation drain holes in the base of the unit are not plugged with dirt or debris.
2. If condensation becomes a problem, optional drain pans are available from your heater distributor or pool dealer.

16. TROUBLESHOOTING

If your unit does not operate, or simply does not heat your pool water, Fault Codes on the front control panel, can provide valuable clues as to what is wrong, and may even indicate precisely what the problem is. Always observe these codes before calling a service representative. By reporting on the telephone the Fault Codes that are showing, the service rep may be able to solve the problem without the expense of a service call.

UNIT IS RUNNING, BUT NOT HEATING

- Is water flow through the unit adequate? Check the unit for obstructions, such as a clogged filter pump strainer, a dirty filter, or valves not positioned correctly. Check the operation of the flow switch.
- Is the ejected air from the unit 8°–10°F (4.5°–5.6°C) cooler than incoming air? If so, the unit is extracting heat from the air and transferring it to the pool.
- Is water condensing on the evaporator and internal copper pipes? This is also evidence of heat removal from the air. When the air is cool with low humidity, condensation may not be evident.
- How long has the unit been operating? During initial pool heating in cold weather, it may require a week to elevate the water temperature to a comfortable level. Normally, it takes about 4-days.

How many hours per day is the unit operating? **Remember that the heater only operates while the pool pump is running.** Set the time clock to permit 24-hour per day operation. After the desired temperature is reached, return the unit to normal operation of 8–10 hours per day.

NOTE: If the pool pump and heater shut OFF before the water temperature is raised to the desired level, you must lengthen the running time of both. To do this, reset the time clock dial for the longer running time, or manually operate the pump with the timer override switch. Since the unit capacity and efficiency are both greater at higher ambient air temperatures, run time should be set to take advantage of all daylight hours, when the air is generally warmer.

- Is airflow through the unit being obstructed? Restrictions such as shrubbery, tall grass, dirty coils, or any other obstruction to airflow will reduce performance.
- Is the pool blanket/cover being used? Unblanketed pools can lose up to 10°F (5.5°C) per night compared to 4°F (2.2°C) or less when a blanket is used. Without a blanket, the total heat gained during the day can be lost overnight.
- Are rapid heat losses occurring in some other way, such as high wind, spillage, rainfall, flow through solar panels at night, or a high water table?

UNIT IS NOT RUNNING

- Is the temperature display on? If not, the circuit breaker may be shut OFF or tripped. Reset the breaker by switching it OFF, and then back ON. Verify that the breaker is set and operating properly before calling for service.
- Is the thermostat setting and the Pool/Spa setting correct? Verify that the temperature has been properly set on the thermostat, and that it is higher than the current water temperature.
- Have you waited approximately 5-minutes for the time delay? After the unit has been running and then shut OFF for any reason, there is a delay before operation can begin again.
- Is the Heat Light ON? If not, then the thermostat setting is not higher than the temperature of the water. Raise the thermostat setting.

NOTE: The heater will not run when the Remote position is selected on the Pool/Spa selector switch and there is no remote control system attached.

CONDENSATION SEEMS EXCESSIVE

Heat pump pool heaters can produce a large amount of condensation (water) during operation. If you suspect that the unit is leaking:

Use a pool chemistry test kit to confirm there is no chlorine in the condensation. Or,

Shut the unit OFF and leave the filter pump running to see if the water stops dripping. If the water stops dripping, the unit is not leaking.

17. SERVICE CALL VERIFICATION

NOTE: The Raypak Service number is 800-260-2758. For units in Canada, call 800-268-6966.

Before you make a service call, first determine if the problem is:

- Warranty Service
- Unit operation (power supply, water flow, or time clock adjustment)

NOTE: The MANUFACTURER IS NOT RESPONSIBLE for these adjustments.

Power Supply

- Verify that all circuit breakers are reset and working properly.
- If the temperature display still does not light, contact the installing dealer, since it may be a power problem requiring an electrician.

Water Flow

- Verify that the pool filter is clean to provide good flow.
- Verify that valves are properly positioned to allow adequate water flow through the unit.

Time Clock Adjustment

Verify that the time clock is set to permit the unit to run long enough to heat properly.

Fault Code	Meaning of Code
OFF	The desired programmed temperature point is lower than 50°F (10°C).
LP	There is a shortage of refrigerant gas in the unit or a faulty low pressure control, or the ambient air is too cold.
LP3	The unit has encountered 3 LP faults within the same call-for-heat and shut down the unit for protection. If this occurs, you should call for service.
HP	There is low water flow in the unit or a faulty high pressure control. Check water flow/backwash.
HP6	The unit has encountered 6 HP faults within the same call-for-heat and shut down the unit for protection. If this occurs, you should call for service.
PSd	The water temperature sensor is open or may be defective.
dSd	The suction line temperature sensor is open or may be defective.
FLO	Possible causes: <ul style="list-style-type: none"> • The filter is in backwash position. • The filter pump is stopped. • The filter is dirty. • Shortage of water to pool pump. • Water flow switch may be broken.
FL3	The unit has encountered 3 FLO faults within the same call-for-heat and shut down the unit for protection. If this occurs, you should call for service.
FS	Unit is in the defrosting cycle.
FS5	The unit has gone into the defrosting cycle 5-times within the same call-for-heat and shut down the unit for protection.
COL	The unit is in the cooling mode.
HEA	The unit is in the heating mode.
HOT	The unit has gone into a fault mode during cooling.
--	Keypad is pressing down on both buttons. Replace keypad.

Table D. Control Board Fault Codes

18. PLUMBING DIAGRAMS

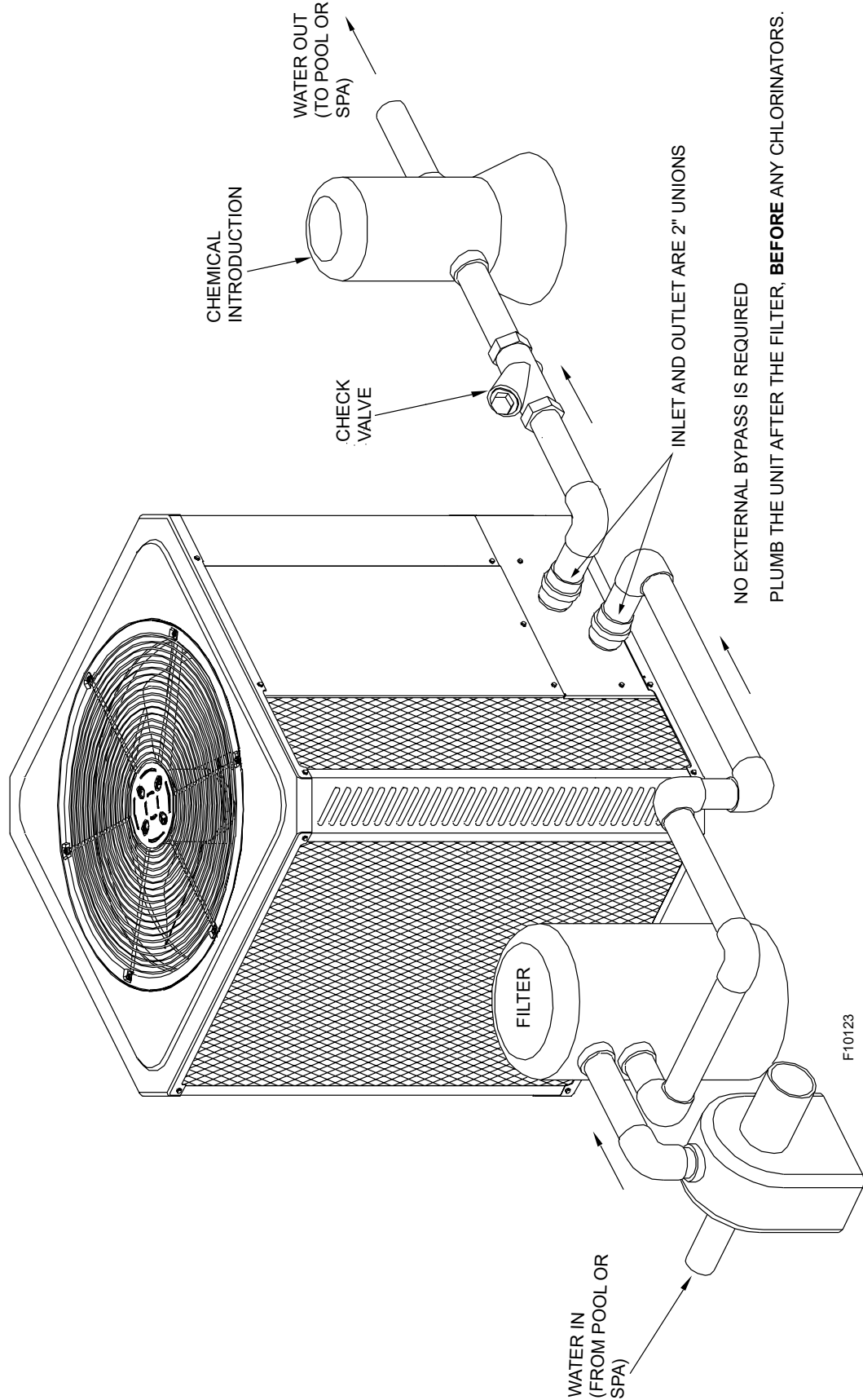

Figure 5. For systems with pumps of less than 2 HP (under 80 gpm)

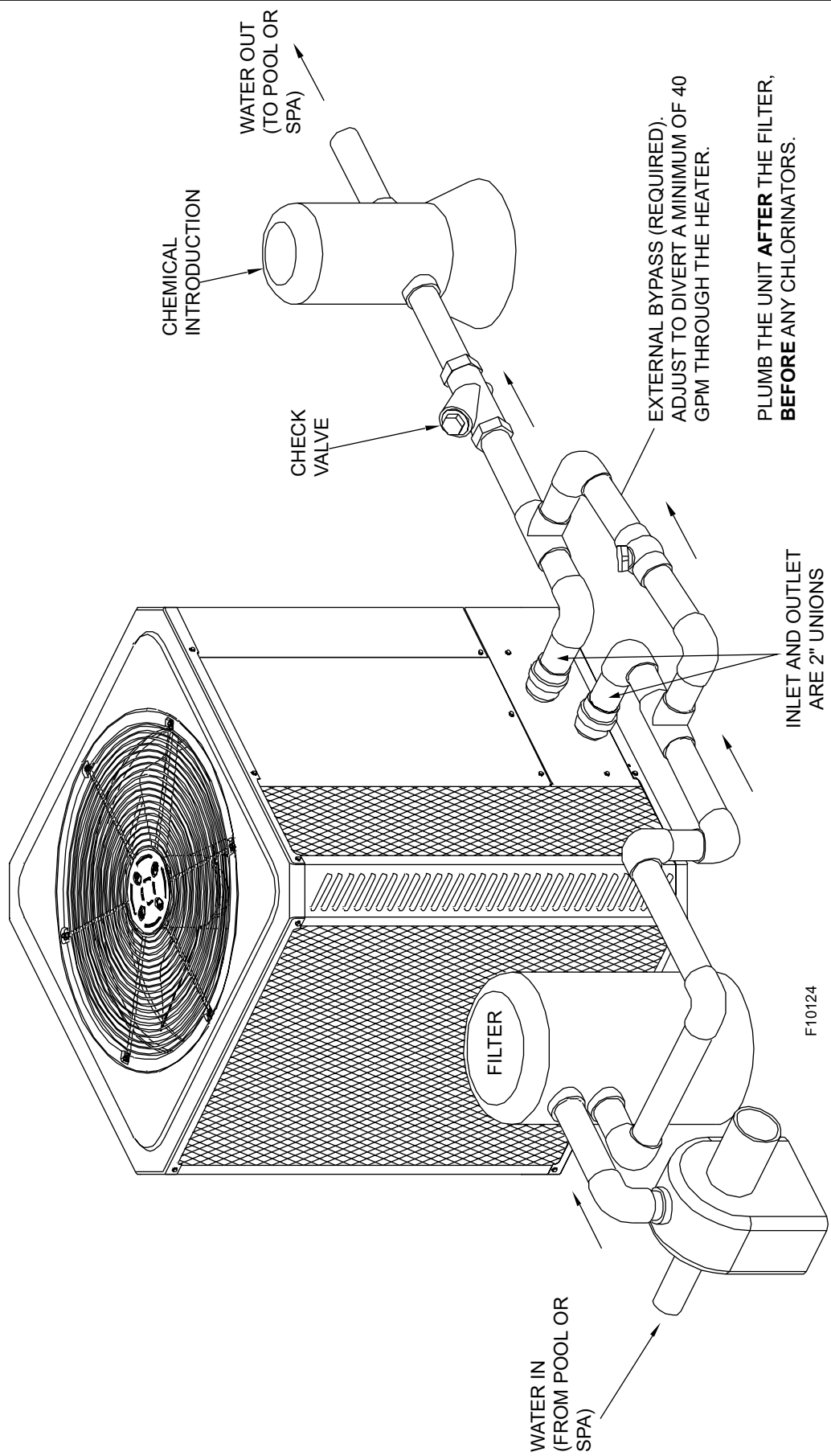
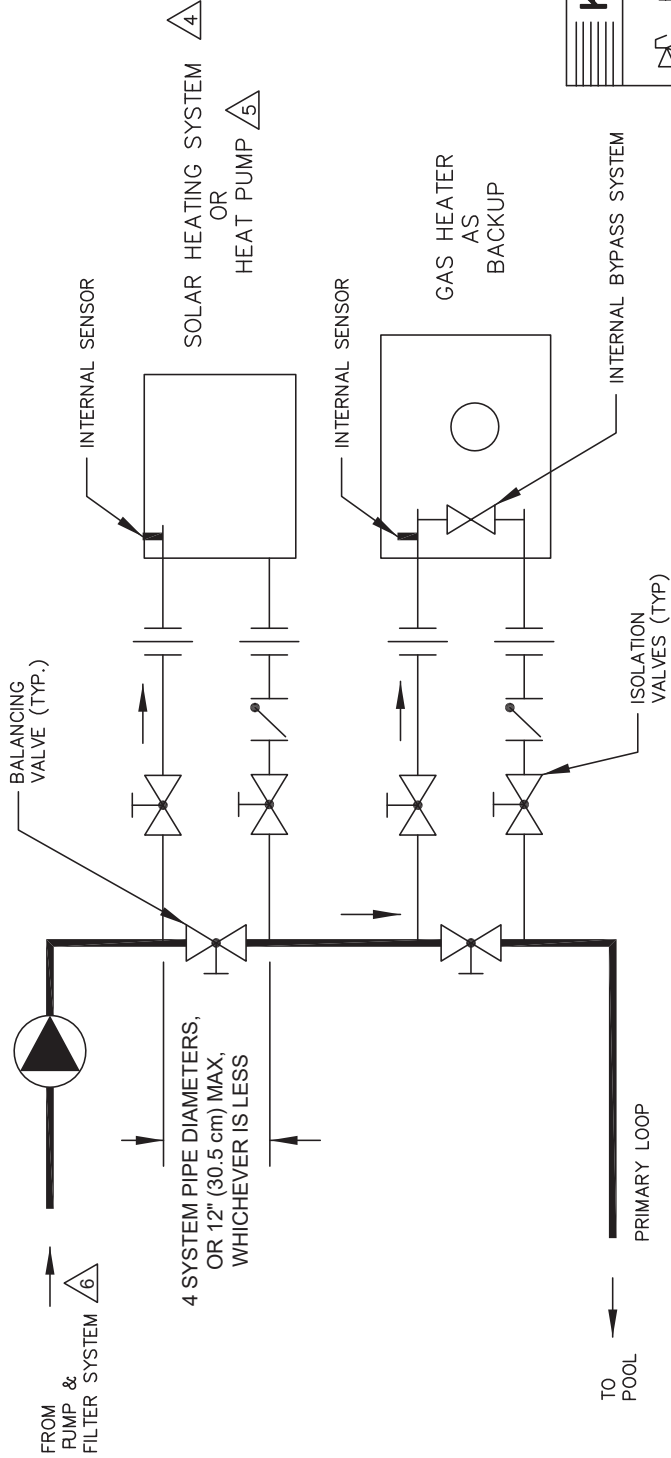

Figure 6. For systems with pumps of 2 HP or greater (over 80 gpm)

THIS PIPING DIAGRAM IS RAYPAK'S RECOMMENDATION AND IS NOT INTENDED TO REPLACE AN ENGINEERED PIPING SYSTEM DESIGNED BY A PROFESSIONAL ENGINEER.



KEY	
	PRESSURE RELIEF VALVE
	PUMP
	UNION
	CHECK VALVE
	BALL VALVE
	THERMOMETER

HEATERS SHOWN REPRESENT VARIOUS MODELS. BECAUSE INDIVIDUAL MODELS WILL VARY IN DESIGN AND SIZING, SEE EACH SPECIFIC HEATER TYPE FOR DETAILS.

- NOTES:
1. PLUMB SWING CHECK VALVE IN GRAVITY-CLOSED POSITION.
 2. PIPE ALL RELIEF VALVES TO DRAIN, OR AS LOCAL CODES REQUIRE.
 3. MINIMUM PIPE SIZE MUST BE EQUAL TO THE HEATER INLET/ OUTLET SIZE.
- △ 4.** SOLAR SYSTEM MUST BE INSTALLED IN ACCORDANCE WITH SOLAR SUPPLIER'S INSTRUCTIONS INCLUDING, BUT NOT LIMITED TO, PROTECTION AGAINST OVERHEATING AND/OR FREEZE-UPS.
- △ 5.** HEAT PUMP MUST BE INSTALLED IN ACCORDANCE WITH SUPPLIER'S INSTRUCTIONS INCLUDING, BUT NOT LIMITED TO, PROTECTION AGAINST OVERHEATING AND/OR FREEZE-UPS.
- △ 6.** SYSTEM FLOW MUST EXCEED 120% OF FLOW THROUGH OPERATING HEATERS.

Figure 7. Pool Piping for Heat Pump Pool Heater and Gas Pool Heater

THIS PIPING DIAGRAM IS RAYPAK'S RECOMMENDATION AND IS NOT INTENDED TO REPLACE AN ENGINEERED PIPING SYSTEM DESIGNED BY A PROFESSIONAL ENGINEER.

2 UNITS		3-4 UNITS		5-6 UNITS	
BRANCH	MAIN	BRANCH	MAIN	BRANCH	MAIN
15 GPM	2"	2"	2"	2"	2"
30	2"	2"	2-1/2"	2"	2"
45	2"	2"	2-1/2"	2"	2"
60	2"	2"	3"	2"	2"
75	2"	2"	3"	2"	2"
90	2"	2"	3"	2"	2"
105	2"	2"	3"	2"	2"
120	2"	2"	3"	2"	2"
135	2"	2"	3"	2"	2"
150	2"	2"	3"	2"	2"
165	2"	2"	3"	2"	2"
180	2"	2"	3"	2"	2"
195	2"	2"	3"	2"	2"
210	2"	2"	3"	2"	2"
225	2"	2"	3"	2"	2"
240	2"	2"	3"	2"	2"
255	2"	2"	3"	2"	2"
270	2"	2"	3"	2"	2"
285	2"	2"	3"	2"	2"
300	2"	2"	3"	2"	2"
315	2"	2"	3"	2"	2"
330	2"	2"	3"	2"	2"
345	2"	2"	3"	2"	2"
360	2"	2"	3"	2"	2"
375	2"	2"	3"	2"	2"
390	2"	2"	3"	2"	2"
405	2"	2"	3"	2"	2"
420	2"	2"	3"	2"	2"
435	2"	2"	3"	2"	2"
450	2"	2"	3"	2"	2"
465	2"	2"	3"	2"	2"
480	2"	2"	3"	2"	2"
495	2"	2"	3"	2"	2"
510	2"	2"	3"	2"	2"
525	2"	2"	3"	2"	2"
540	2"	2"	3"	2"	2"
555	2"	2"	3"	2"	2"
570	2"	2"	3"	2"	2"
585	2"	2"	3"	2"	2"
600	2"	2"	3"	2"	2"
615	2"	2"	3"	2"	2"
630	2"	2"	3"	2"	2"
645	2"	2"	3"	2"	2"
660	2"	2"	3"	2"	2"
675	2"	2"	3"	2"	2"
690	2"	2"	3"	2"	2"
705	2"	2"	3"	2"	2"
720	2"	2"	3"	2"	2"
735	2"	2"	3"	2"	2"
750	2"	2"	3"	2"	2"
765	2"	2"	3"	2"	2"
780	2"	2"	3"	2"	2"
795	2"	2"	3"	2"	2"
810	2"	2"	3"	2"	2"
825	2"	2"	3"	2"	2"
840	2"	2"	3"	2"	2"
855	2"	2"	3"	2"	2"
870	2"	2"	3"	2"	2"
885	2"	2"	3"	2"	2"
900	2"	2"	3"	2"	2"
915	2"	2"	3"	2"	2"
930	2"	2"	3"	2"	2"
945	2"	2"	3"	2"	2"
960	2"	2"	3"	2"	2"
975	2"	2"	3"	2"	2"
990	2"	2"	3"	2"	2"
1005	2"	2"	3"	2"	2"
1020	2"	2"	3"	2"	2"
1035	2"	2"	3"	2"	2"
1050	2"	2"	3"	2"	2"
1065	2"	2"	3"	2"	2"
1080	2"	2"	3"	2"	2"
1095	2"	2"	3"	2"	2"
1110	2"	2"	3"	2"	2"
1125	2"	2"	3"	2"	2"
1140	2"	2"	3"	2"	2"
1155	2"	2"	3"	2"	2"
1170	2"	2"	3"	2"	2"
1185	2"	2"	3"	2"	2"
1200	2"	2"	3"	2"	2"

*Sizing based on 10 ft/sec flow rates

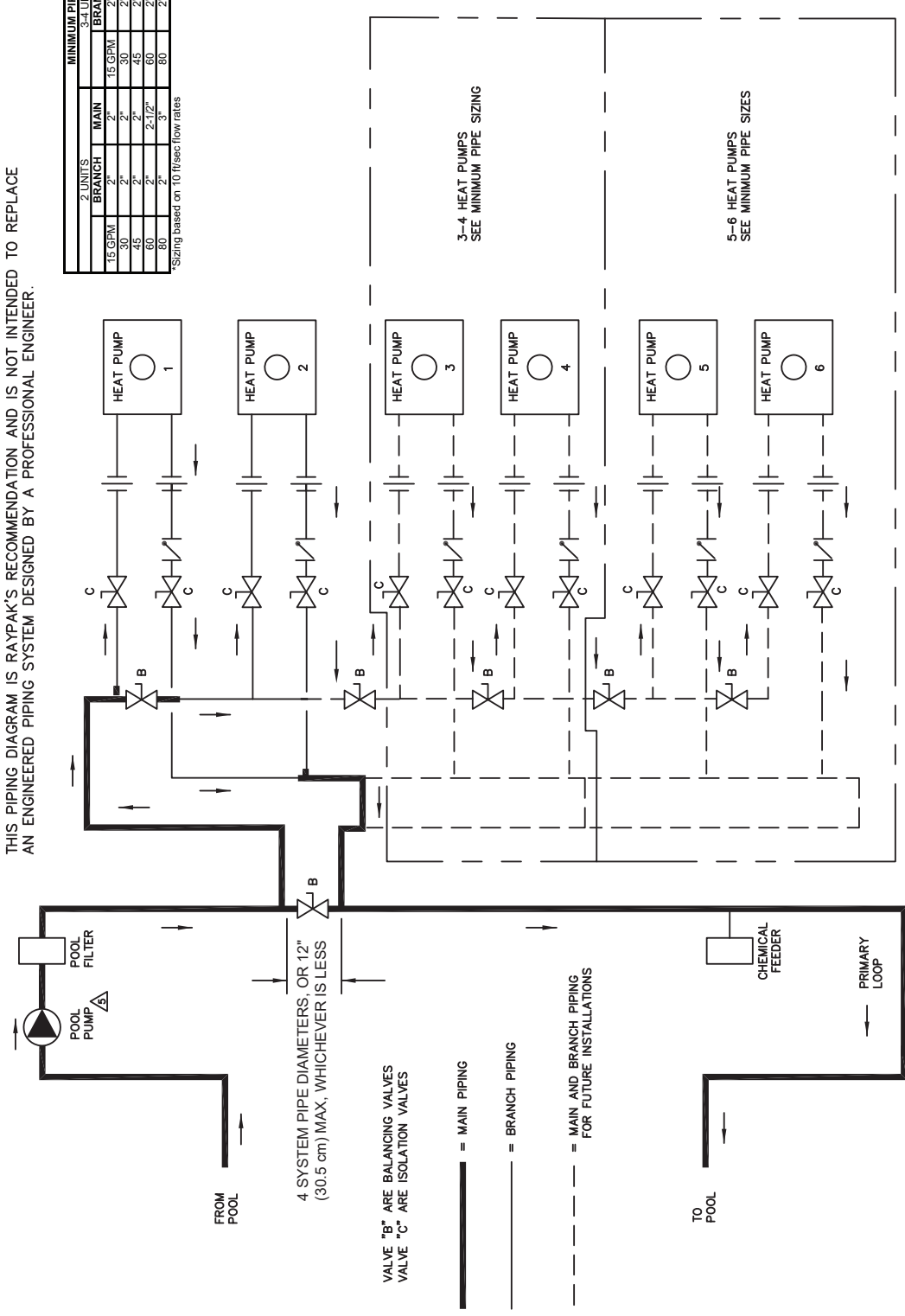

KEY	
	PRESSURE RELIEF VALVE
	PUMP
	UNION
	GATE VALVE
	CHECK VALVE
	BALL VALVE
	THERMOMETER

HEAT PUMP SHOWN REPRESENTS VARIOUS INDIVIDUAL MODELS WILL VARY IN DESIGN AND SIZING. SEE EACH SPECIFIC HEAT PUMPS TYPE FOR DETAILS.

- NOTES:
1. PLUMB SWING CHECK VALVE IN GRAVITY-CLOSED POSITION.
 2. MINIMUM PIPE SIZE MUST BE EQUAL TO THE HEATER INLET/ OUTLET SIZE. SEE "MINIMUM PIPE SIZES" CHART ABOVE.
- △ SYSTEM FLOW MUST EXCEED 120% OF FLOW THROUGH OPERATING HEATERS.

Figure 8. Pool Piping for Multiple Heaters

19. WIRING DIAGRAMS

208V/230V 3Ph, 60Hz Models

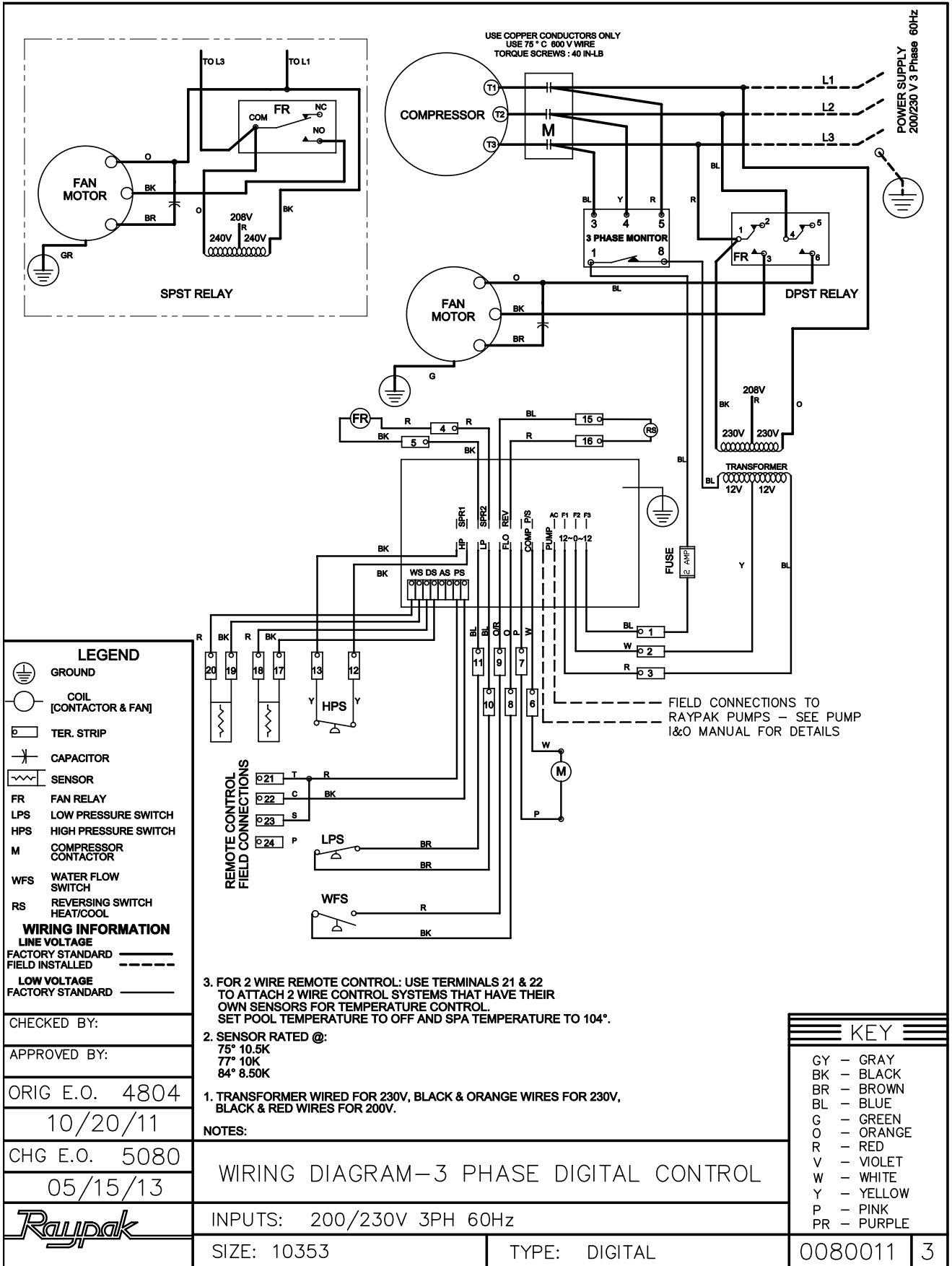

460V 3Ph, 60 Hz Models

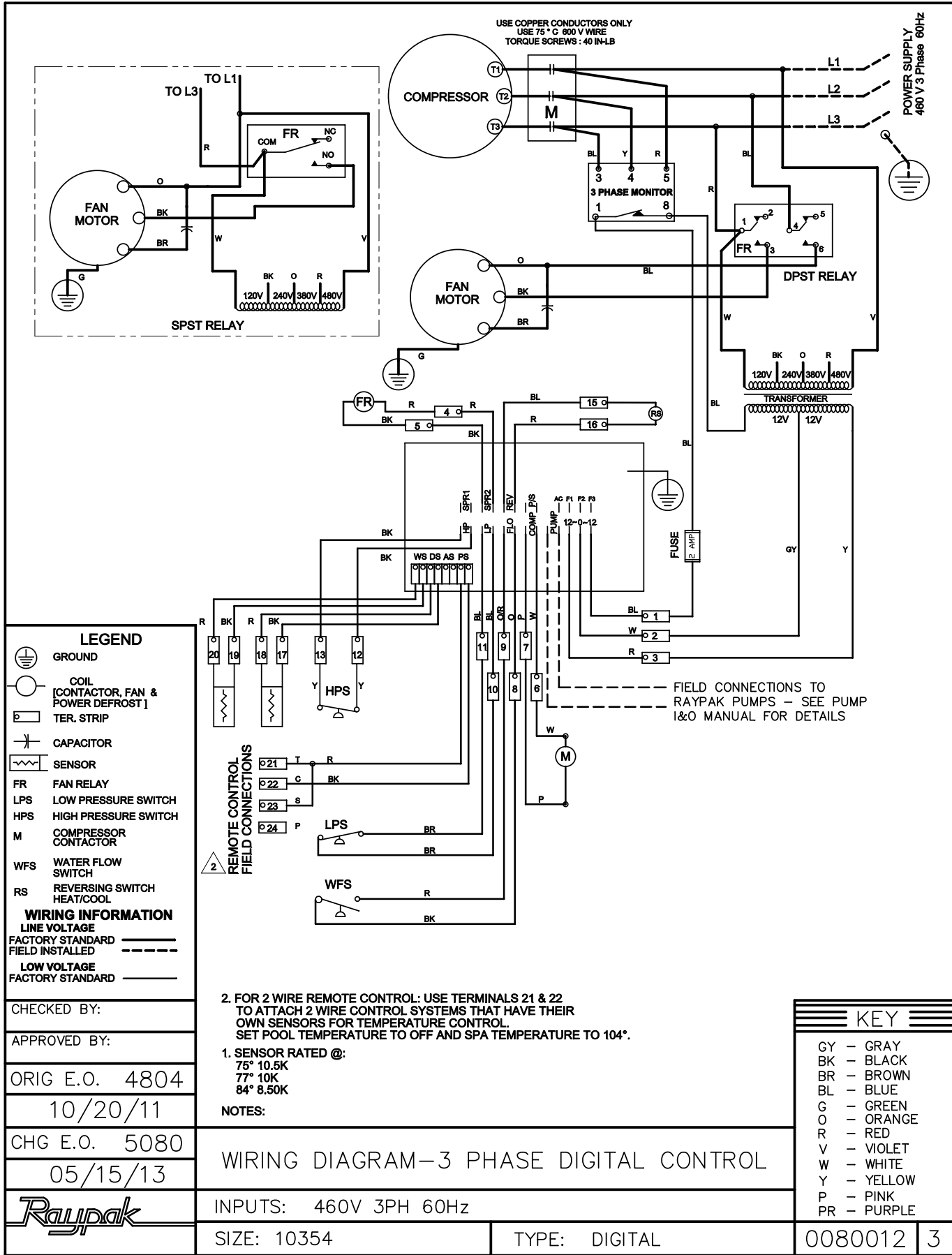

380V 3Ph, 60 Hz Models

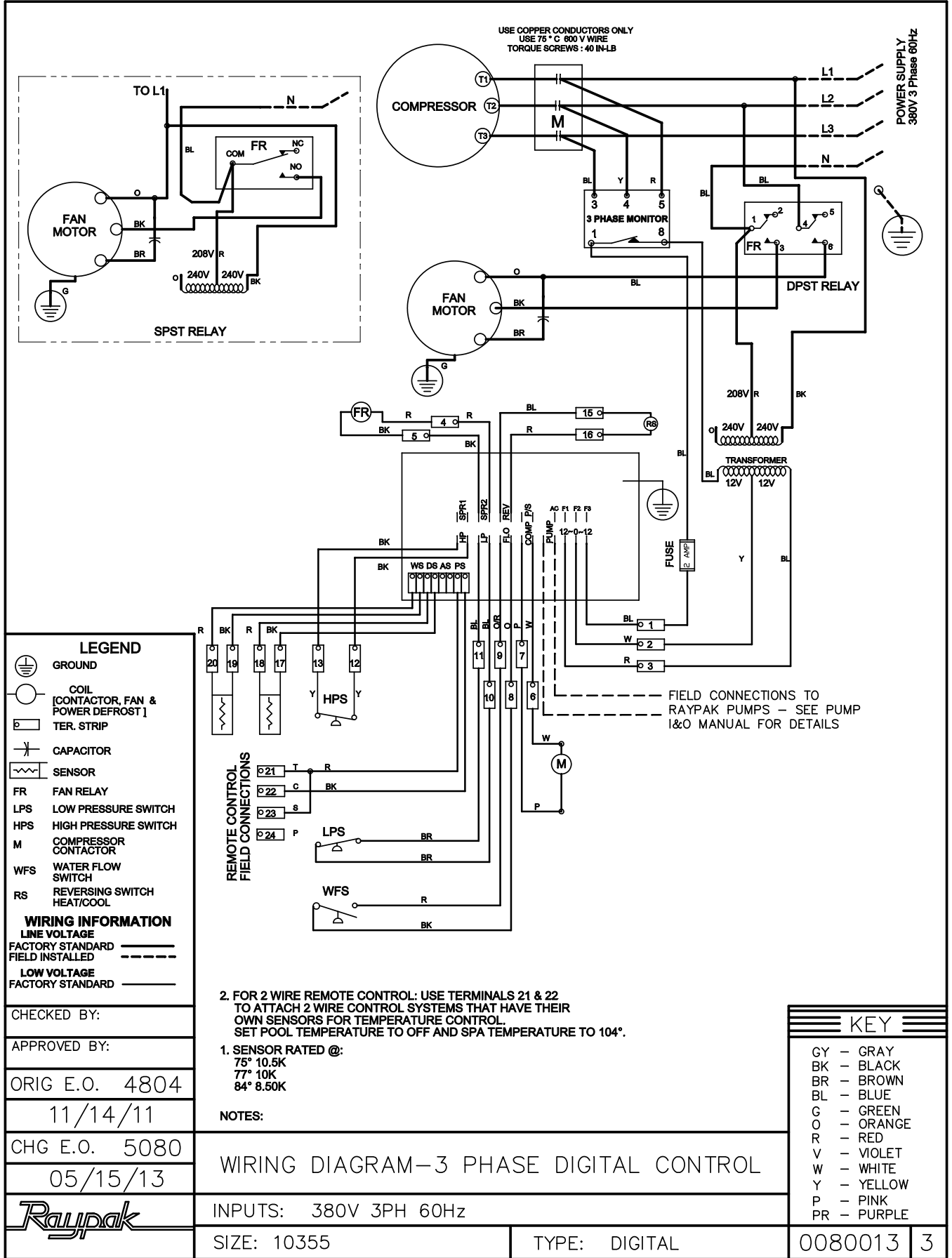

20. INSTALLING A REMOTE CONTROL DEVICE

Wiring

For a 2-wire control, use the TOTAL and COMMON connections on the heater wiring block.

For a 3-wire control, use the COMMON, SPA and POOL connections on the heater wiring block.

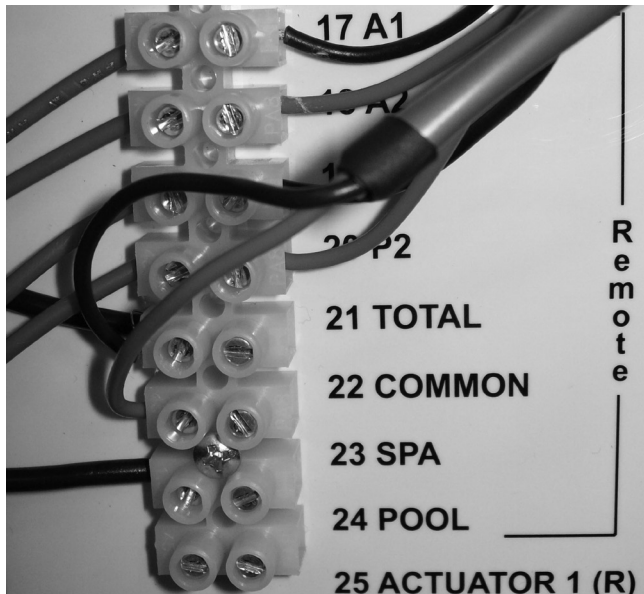
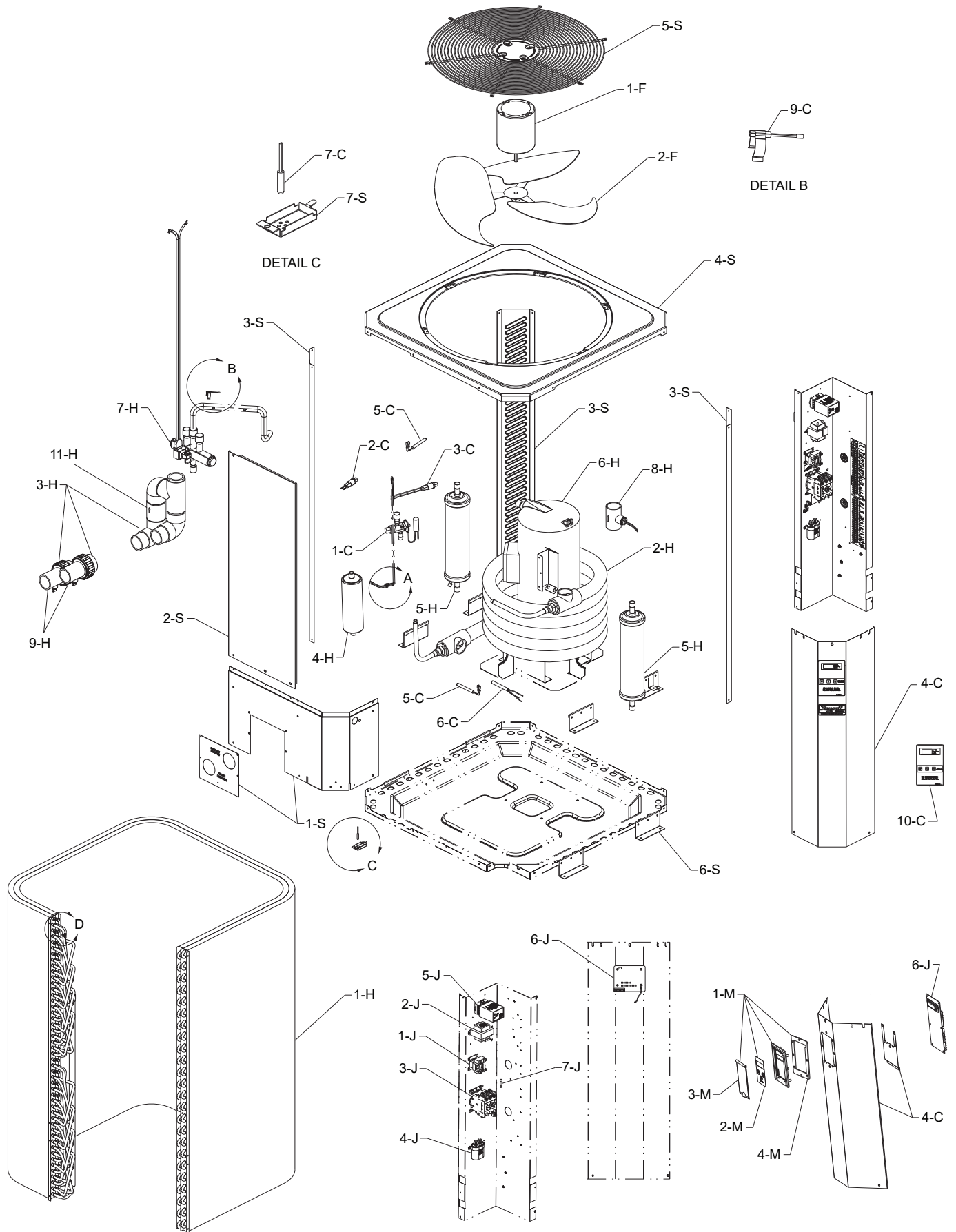

Figure 9. Heater Wiring Block

Heater Settings

1. Make sure the heater is disabled on the remote control device. Then, push the SET key until POL is displayed. Push the DOWN arrow key until OFF is displayed. Wait until a temperature is displayed before beginning the next step.
2. Push the SET key until SPA is displayed, then push the UP arrow to 104°F (40°C). Wait until a temperature is displayed before beginning the next step.
3. Push the SET key until P_S is displayed, then push the DOWN arrow until POL is displayed. Wait until a temperature is displayed before beginning the next step.
4. Finally, enable the heater on the remote control device. When there is a call-for-heat, the heater display will show SPA. When the heater is disabled, the display will show POL.

21. ILLUSTRATED PARTS LIST



CALLOUT	DESCRIPTION	9350	9353	10353	10354	10355
CONTROLS						
1-C	TX Valve	H000173	H000173	H000248	H000248	H000248
2-C	Low Pressure Switch	H000078	H000078	H000249	H000249	H000249
3-C	High Pressure Switch	H000079	H000079	H000079	H000079	H000079
4-C	Control Cover					
	Digital with Plastic Bezel	H000324	H000324	N/A	N/A	N/A
	Digital (Includes 10-C)	N/A	N/A	H000250	H000250	H000250
	Units manufactured prior to 5/15/17	N/A	N/A	H000250	H000250	H000250
	Units manufactured from 5/15/17			H000367	H000367	H000367
10-C	Control Label	N/A	N/A	H000330	H000330	H000330
5-C	Temperature Sensor 10K	N/A	N/A	H000002	H000002	H000002
6-C	Temperature Sensor 100K	H000329	H000329			
7-C	Ambient Temp Sensor	H000332	H000332	H000332	H000332	H000332
9-C	Thermister 7/8" Tube	H000334	H000334			
HEAT TRANSFER						
1-H	Evaporator Coil	H000328	H000328	H000251	H000251	H000251
2-H	Heat Exchanger	H000252	H000252	H000252	H000252	H000252
3-H	Bypass Assembly	H000253	H000253	H000253	H000253	H000253
9-H	PVC Union			N/A	N/A	N/A
	PVC Union with Built-In Drain	H000317	H000317	H000317	H000317	H000317
11-H	Check Valve	100-10001222	100-10001222	100-10001222	100-10001222	100-10001222
4-H	Liquid Line Drier	H000004	H000004	H000254	H000254	H000254
5-H	Charge Compensator	H000255	H000255	H000255	H000255	H000255
6-H	Compressor					
	1-Phase	H000014				
	3-Phase		H000110	H000256	H000257	H000258
10-H	Compressor Wire Harness (Not shown)			H000272	H000272	H000272
	Compressor Power Plug (Not shown)	H000271	H000271			
7-H	Reversing Valve	H000136	H000136	H000259	H000259	H000259
8-H	Flow Switch	H000166	H000166	H000166	H000166	H000166
FAN						
1-F	Fan Motor	H000296	H000296	H000260	H000268	H000260
2-F	Fan Blade	H000297	H000297	H000044	H000044	H000044
CONTROL BOX						
1-J	Fan Relay					
	SPST (Units manufactured prior to 4/1/13)			H000017	H000017	H000017
	DPST (Units manufactured from 4/1/13)	H000299	H000299	H000299	H000299	H000299
2-J	Transformer			H000021	H000021	H000021
	Units manufactured prior to 5/15/17	H000331	H000331	H000021	H000021	H000021
	Units manufactured from 5/15/17	H000331	H000331	H000331	H000331	H000331
3-J	Contactator					
	1-Phase	H000043				
	3-Phase		H000114	H000261	H000261	H000261
4-J	Capacitor					
	1-Phase	H000051	H000051			
	3-Phase	H000265	H000265	H000117	H000117	H000117
5-J	Monitor 3 PH					
	Line Voltage 1 PH	H000291				
	3 PH	H000111	H000111	H000111	H000111	H000111
6-J	Control Board					
	Units manufactured prior to 5/15/17	100-10000347	100-10000347	H000029	H000029	H000029
	Units manufactured from 5/15/17			100-10000347	100-10000347	100-10000347
7-J	Fuse					
	Units manufactured prior to 5/15/17			H000001	H000001	H000001
	Units manufactured from 5/15/17	H000370	H000370	H000370	H000370	H000370
MISCELLANEOUS COMPONENTS						
1-M	Control Bezel Digital (Includes Switch Decal)	H000325	H000325	H000325	H000325	H000325
2-M	Switch/Decal Membrane	H000326	H000326	H000326	H000326	H000326
3-M	Control Bezel Cover	H000327	H000327	H000327	H000327	H000327
4-M	Bezel Seal Gasket	H000344	H000344	H000344	H000344	H000344
SHEETMETAL						
1-S	Electrical Input Panel	H000204	H000204	H000204	H000204	H000204
2-S	Access Panel	H000206	H000206	H000263	H000263	H000263
3-S	Corner Jacket Panel	H000217	H000217	H000264	H000264	H000264
4-S	Jacket Top	H000209	H000209	H000209	H000209	H000209
5-S	Grille Fan Guard	H000040	H000040	H000266	H000266	H000266
6-S	Hurricane Bracket	H000323	H000323	H000323	H000323	H000323
7-S	Temperature Sensor Cover	H000335	H000335	H000335	H000335	H000335

NOTES
