

RBI®
RELIABLE. BOLD. INNOVATIVE.



FLEXCORE®
SYMMETRICAL FIRETUBE

Boiler Manual

Installation and Operation Instructions

Stainless Steel Condensing Boilers

Models CK1000, CK1500, CK2000,
CK2500, CK3000, CK3500, CK4000,
CK4500, CK5000, CK6000

Also read and follow:

- HeatNet Control Manual
- High Turndown Troubleshooting Manual
- Annual Preventative Maintenance Manual

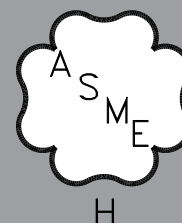

⚠ WARNING This manual is intended only for use by a qualified heating installer/technician. Read and follow this manual, all supplements and related instructional information provided with the boiler. Install, start and service the boiler only in the sequence and methods given in these instructions. Failure to do so can result in severe personal injury, death or substantial property damage.

⚠ WARNING **Do not use the boiler during construction.** Construction dust and particulate, particularly drywall dust, will cause contamination of the burner, resulting in possible severe personal injury, death or substantial property damage. The boiler can only be operated with a dust-free air supply. Follow the instruction manual procedures to duct air to the boiler air intake. If the boiler has been contaminated by operation with contaminated air, follow the instruction manual guidelines to clean, repair or replace the boiler if necessary.

⚠ CAUTION Affix these instructions near to the boiler. Instruct the building owner to retain the instructions for future use by a qualified service technician, and to follow all guidelines in the User's Information Manual.

⚠ WARNING If the information in this manual is not followed exactly, a fire or explosion may result causing property, personal injury or loss of life.

Do not store or use gasoline or other flammable vapors and liquids in the vicinity of this or any other appliance.

WHAT TO DO IF YOU SMELL GAS:

- **Do not try to light any appliance.**
- **Do not touch any electrical switch. Do not use any phone in your building.**
- **Immediately call your gas supplier from a phone outside of the building. Follow the gas supplier's instructions.**
- **If you cannot reach your gas supplier, call the fire department.**

Installation and service must be performed by a qualified installer, service agency or the gas supplier.

⚠ WARNING Failure to properly vent this unit can cause excessive amounts of carbon monoxide resulting in severe personal injury or death!

⚠ CAUTION Do not use automotive anti-freeze in the boiler waterways. If the use of anti-freeze is necessary an anti-freeze specifically formulated for hydronic heating systems must be used or damage to the boiler may occur voiding the warranty!

DESIGNED AND TESTED ACCORDING TO A.S.M.E. BOILER AND PRESSURE VESSEL CODE, SECTION IV FOR A MAXIMUM ALLOWABLE WORKING PRESSURE OF 160 PSI, 1103 kPa WATER.

INSTALLER, THESE INSTRUCTIONS TO BE AFFIXED ADJACENT TO THE BOILER.

CONSUMER, RETAIN THESE INSTRUCTIONS FOR FUTURE REFERENCE PURPOSES.

CONTENTS

Before Your Start	page 2
Ratings & Capacities	page 3
Location	page 3
Combustion Air & Ventilation	page 3
Venting Guidelines.....	page 5
Common Vent Systems	page 15
General Piping Requirements	page 19
Heating System Piping	page 20
Domestic Water Supply Piping	page 23
Condensate Piping	page 25
Gas Supply Piping	page 25
Electrical Wiring.....	page 26
Boiler Operation.....	page 28
Operating Instructions	page 29
Sequence of Operation.....	page 36
Ignition Troubleshooting	page 38
Checking & Adjustment	page 39
Diagnostics	page 40
Maintenance	page 41
Pressure Switches.....	page 42
Wiring	page 44
Repair Parts.....	page 45
Start-Up	page 53
Mass Code	page 55
Warranty	page 56

BEFORE YOU START

This manual covers the application, installation, operation and maintenance of a FlexCore series boiler.

To obtain the safe, dependable, efficient operation and long life for which this boiler was designed, these instructions must be read, understood and followed.

The FlexCore boiler series has been design certified by CSA for use with natural gas under the latest revision of ANSI-Z21.13/CSA 4.9, Gas-Fired Hot Water Boilers. Each unit has been constructed and hydrostatically tested for a maximum working pressure of 160 psi, 1103 kPa, in accordance with Section IV of the A.S.M.E. Boiler and Pressure Vessel Code.

All aspects of the boiler installation must conform to the requirements of the authority having jurisdiction, or, in the absence of such requirements, to the National Fuel Gas Code, ANSI Z223.1/NFPA 54-latest revision. Where required by the authority having jurisdiction, the installation must conform to the Standard for Controls and Safety Devices for Automatically Fired Boilers, ANSI/ASME CSD-1.

If installed in the Commonwealth of Massachusetts, you **MUST FOLLOW** the additional instructions contained in RBI's instruction sheet, MACODE-3. Please refer to the back of this manual for required regulations.

In Canada, the installation must be in accordance with the requirements of CSA B149.1 or .2, Installation Code for Gas Burning Appliances and Equipment.

The owner should maintain a record of all service work performed with the date and a description of the work done. Include the name of the service organization for future reference.

Direct all questions to your RBI distributor or contact the RBI Technical Services at (833) 265-5371. Always have available the model and serial numbers from the rating plate of the boiler/water heater in question.

RATINGS & CAPACITIES

Before installing the FlexCore boiler check the rating plate to ensure that the unit has been sized properly for the job. Also ensure that the unit has been set up for the type of gas available at the installation site. Other important considerations are the availability of an adequate electrical supply, fresh air for combustion and a suitable vent system.

BOILER LOCATION

1. This boiler is suitable for indoor installations only. Locate the boiler in an area that provides good access to the unit. Servicing may require the removal of jacket panels. Allow the minimum clearances between adjacent construction and the boiler as listed in Table 1.

NOTICE Service clearances are not mandatory, but are recommended to ensure ease of service should it be required.

Table 1 - Clearances

	Clearance to Combustibles		Service Clearance	
	in	mm	in	mm
Top	6	153	30	762
Back	6	153	24	610
Left Side	6	153	24	610
Right Side	6	153	24	610
Front	6	153	36	914
Flue	6	153		

2. An optimum site will be level, central to the piping system, close to a chimney or outside wall and have adequate fresh air for combustion. Ensure that the unit is level from front to back and from side to side. Use metal shims if leveling is required. Electrical and electronic components must be protected from exposure to water during operation and maintenance. DO NOT install this boiler in a location that would subject any of the gas ignition and other electronic components to direct contact with water or excessive moisture during operation or servicing.
3. Ensure that the floor is structurally sound and will support the weight of the boiler.

NOTICE The FlexCore may be installed directly on combustible flooring, but never on carpeting.

4. Locate the boiler in an area that will prevent water damage to adjacent construction should a leak occur or during routine maintenance.
5. DO NOT place this boiler heater in a location that would restrict the introduction of combustion air into the unit or subject it to a negative pressure, see the "COMBUSTION AIR & VENTILATION" and "GENERAL VENTING GUIDLINES".
6. **NEVER** place this boiler in a location that would subject it to temperatures at or near freezing.

WARNING Never store combustible materials, gasoline or any product containing flammable vapors or liquids in the vicinity of the boiler. Failure to comply with this warning can result in an explosion or fire causing extensive property damage, severe personal injury or death!

COMBUSTION AIR & VENTILATION

WARNING This boiler must be supplied with combustion air in accordance with Section 9.3, Air for Combustion & Ventilation, of the latest revision of the National Fuel Gas Code, ANSI Z223.1/ NFPA 54 and all applicable local building codes. Canadian installations must comply with CSA B149.1 or .2 Installation Code for Gas Burning Appliances and Equipment, or applicable provisions of the local building codes. Failure to provide adequate combustion air for this boiler can result in excessive levels of carbon monoxide which can result in severe personal injury or death!

To operate properly and safely this boiler requires a continuous supply of air for combustion. **NEVER** store objects on or around the boiler!

CAUTION Combustion air contaminated with fluorocarbons or other halogenated compounds such as cleaning solvents and refrigerants will result in the formation of acids in the combustion chamber. These acids will cause premature failure of the boiler voiding the warranty!

CAUTION If the boiler is operated while the building is under construction it must be protected from wood, concrete, sheet rock and other types of dust. Failure to properly protect the unit from construction dust will damage the unit voiding the warranty!

Buildings will require the installation of a fresh air duct or other means of providing make-up air if the intake air option isn't used. Any building utilizing other gas burning appliances, a fireplace, wood stove or any type of exhaust fan must be checked for adequate combustion air when all of these devices are in operation at one time. Sizing of an outside air duct must be done to meet the requirements of all such devices.

⚠ WARNING Never operate the FlexCore in an environment subjected to a negative pressure. Failure to comply with this warning can result in excessive levels of carbon monoxide causing severe personal injury or death!

All Air From Inside The Building

If the boiler is to be located in a confined space the minimum clearances listed in Table 1 must be maintained between it and any combustible construction. When installed in a confined space without the intake air option two permanent openings communicating with an additional room(s) are required. The combined volume of these spaces must have sufficient volume to meet the criteria for an unconfined space. The total air requirements of all gas utilization equipment, fireplaces, wood stoves or any type of exhaust fan must be considered when making this determination. Each opening must have a minimum free area of **1 in²/1000 Btu/hr, 2200 mm²/kW** based on the total input rating of ALL gas utilization equipment in the confined area. Each opening must be no less than **100 in², 64,516 mm²** in size. The upper opening must be within **12 in, 300 mm** of, but not less than **3 in, 80 mm** from, the top of the enclosure. The bottom opening must be within **12 in, 300 mm** of, but not less than **3 in, 80 mm** from, the bottom of the enclosure.

All Air From Outside The Building

When installed in a confined space without the intake air option two permanent openings communicating directly with, or by ducts to, the outdoors or spaces that freely communicate with the outdoors must be present. The upper opening must be within **12 in, 300 mm** of, but not less than **3 in, 80 mm** from, the top of the enclosure. The bottom opening must be within **12 in, 300 mm** of, but not less than **3 in, 80 mm** from, the bottom of the enclosure.

Where directly communicating with the outdoors or communicating with the outdoors through vertical ducts, each opening shall have a minimum free area of **1 in²/4000 Btu/hr, 550 mm²/kW** of the total input rating of all of the equipment in the enclosure.

Where communicating with the outdoors through horizontal ducts, each opening shall have a minimum free area of **1 in²/2000 Btu/hr, 1100 mm²/kW** of the total input rating of all of the equipment in the enclosure.

When ducts are used, they must have the same cross-sectional area as the free area of the opening to which they connect.

Table 2 - Make-up Air Duct Sizing

Input (MBH)	Required Cross Sectional Duct Area					
	1/4 in, 6.4 mm Wire Screen		Metal Louvers		Wooden Louvers	
	in ²	cm ²	in ²	cm ²	in ²	cm ²
1000	250	1613	333	2148	1000	6452
1500	375	2419	500	3226	1500	9677
2000	500	3226	667	4303	2000	12903
2500	635	4031	833	5382	2500	16127
3000	750	4838	1000	6452	3000	19354
3500	875	5645	1167	7522	3500	22581
4000	1000	6452	1334	8592	4000	25808
4500	1125	7257	1500	9678	4500	29031
5000	1250	8065	1666	10748	5000	32258
6000	1500	9676	2000	12904	6000	38708

When calculating the free area necessary to meet the make-up air requirements of the enclosure, consideration must be given to the blockage effects of louvers, grills and screens.

Screens must have a minimum mesh size of **1/4 in, 6.4 mm**. If the free area through a louver or grill is not known ducts should be sized per Table 2.

Direct Intake Air Option - General

This configuration provides combustion air directly to the boiler's air intake using a dedicated pipe when using the direct vent option. Combustion air can be drawn in horizontally through an outside wall or vertically through the roof, see Figures 2, 3, 4 & 5. It must be sized per Table 3.

Single wall galvanized smoke pipe, single wall aluminum pipe, flexible aluminum pipe, PVC or CPVC pipe can be used for the intake air pipe.

Table 3 - Intake Air Pipe Sizing

Model Size	Pipe Diameter	
	in	mm
1000	6	153
1500	8	204
2000	8	204
2500	8	204
3000	8	204
3500	10	254
4000	10	254
4500	10	254
5000	12	305
6000	12	305

NOTICE All joints in metal intake air systems must be secured using corrosion resistant fasteners and sealed using a suitable Silicone caulk. If PVC or CPVC is used, the joints must be cleaned with a suitable solvent and connected using a solvent based PVC cement. The intake air system **MUST** be supported by the building structure not the boiler.

Direct Intake Air Option - Vertical

The maximum equivalent length for the vertical intake air pipe is **100 ft, 30.5 m**. Each 90° mitered elbow and the intake air cap are equal to **10 ft, 3.3 m** of straight pipe. If 90° long sweep elbows are installed use the manufacturers recommended equivalent length.

A listed, nonrestrictive intake air cap must be used. The intake air cap must terminate as shown in Figure 4. The penetration point in the roof must be properly flashed and sealed.

Direct Intake Air Option - Horizontal

The maximum equivalent length for the horizontal intake air pipe is **100 ft, 30.5 m**. Each 90° mitered elbow and the intake air terminal are equal to **10 ft, 3.3 m** of straight pipe. If 90° long sweep elbows are installed use the manufacturers recommended equivalent length.

Horizontal runs that exceed **5 ft, 1.5 m** must be supported at **3 ft, 0.98 m** intervals with overhead hangers. The intake air terminal must terminate as shown in Figures 2, 3 or 5.

GENERAL VENTING GUIDELINES

⚠ WARNING The vent installation must be in accordance with Part 7, Venting of Equipment, of the National Fuel Gas Code, ANSI Z223.1/NFPA 54-latest revision or applicable provisions of the local building codes. Canadian installations must comply with CSA B149.1 or .2 Installation Code. See Figure A for added clarity. Improper venting can result in excessive levels of carbon monoxide which can result in severe personal injury or death! Boiler shall not be connected to a chimney flue serving a separate appliance, designed to burn solid fuel.

All vent systems must be fully supported by the building structure and not by the boiler. Appropriate thimbles and fire-stops must be used where required.

⚠ WARNING Improper installation of common positive pressure vent systems can result in excessive levels of carbon monoxide which can cause severe personal injury or death!

NOTICE For Category II and IV appliances the vent shall not terminate:

- 1) over public walkways; or
- 2) near soffit vents or crawl spaces or other areas where condensate or vapor could create a nuisance or hazard or cause property damage; or
- 3) where condensate vapor could cause damage or could be detrimental to the operation of regulators, relief valves, or other equipment.

NOTICE A barometric damper or blast gate as required, must be installed if a Category II vertical vent system produces a negative draft in excess of **0.10 in, 2.5 mm WC** at the flue outlet. Size the vent system per local codes and the vent pipe manufacturers requirements, using generally accepted engineering practices.

NOTICE For instructions utilizing the non-metallic vent option, see Addendum (F-PVS-IOM-1) for PVC and (F-DVS-IOM-1/FCR-PPVCT-1) for Polypropylene.

VENT SYSTEM OPTIONS

The FlexCore may be vented the following ways:

1) **Direct Vent (individual venting only) (page 11 & 12)** - Positive Pressure, Category IV uses a stainless steel vent system certified to UL 1738 for installations in the United States, and a stainless steel vent system certified to ULC S636 for installations in Canada. Combustion air is piped from the outdoors to the blower inlet.

2) **Side Wall Vent (individual venting only) (page 13)** - Positive Pressure, Category IV uses a stainless steel vent system certified to UL 1738 for installations in the United States, and a stainless steel vent system certified to ULC S636 for installations in Canada. Combustion air is obtained from the space in which the unit is installed.

⚠ WARNING To ensure proper operation, boilers that are sidewall vented and use room air must not be fired less than 10% input.

3) **Vertical Vent (individual venting only) (page 13)** - Positive Pressure, Category IV uses a stainless steel vent system certified to UL 1738 for installations in the United States, and a stainless steel vent system certified to ULC S636 for installations in Canada. Combustion air is obtained from the space in which the unit is installed.

- 4) **Vertical Vent (individual venting only) (page 14)**
 - Negative Pressure, Category II uses stainless steel vent system certified to UL 1738 for installations in the United States, and a stainless steel vent system certified to ULC S636 for installation in Canada. Combustion air is obtained from the space in which the unit is installed.
- 5) **Common Vent (page 10) - Negative Pressure, Category II** uses a stainless steel vent system certified to UL 1738 for installations in the United States, and a stainless steel vent system certified to ULC S636 for installations in Canada.

NOTICE Abnormal wind patterns may effect overall performance.

⚠WARNING Use (Table 4) for the maximum Category (IV) equivalent vent length and the equivalent length per fitting. Table 4 - “Category IV Equivalent Length per Fitting” chart is meant as a guideline for preliminary sizing. If vent length approaches 75% of maximum length listed, an engineered vent system calculation must be performed. Consult factory.

Table 4 - Category IV Maximum Equivalent Vent Length & Equivalent Length per Fitting

Model/Outlet Diameter	K*	1000	1500	2000	2500	3000	3500	4000	4500	5000	6000
		5"	6"	6"	8"	8"	10"	10"	10"	12"	12"
Maximum Equivalent Length (Category IV)		100'	100'	100'	100'	100'	100'	100'	100'	100'	100'
Standard Tee	1.25	25 ft	25 ft	30 ft	35 ft	35 ft	40 ft	40 ft	40 ft	50 ft	50 ft
Boot Tee	0.65	15 ft	15 ft	15 ft	15 ft	15 ft	20 ft	20 ft	20 ft	25 ft	25 ft
Cap - Low Res (UL)	0.50	10 ft	10 ft	15 ft	15 ft	15 ft	15 ft	15 ft	15 ft	20 ft	20 ft
45° w/Bird Screen	0.40	10 ft	10 ft	10 ft	10 ft	10 ft	15 ft	15 ft	15 ft	15 ft	15 ft
Elbow - 90°	0.38	10 ft	10 ft	10 ft	10 ft	10 ft	15 ft	15 ft	15 ft	15 ft	15 ft
Elbow - 45°	0.15	5 ft	5 ft	5 ft	5 ft	5 ft	7 ft	7 ft	7 ft	7 ft	7 ft

*Equivalent lengths based on K factors and (5X) pipe diameters straight length between fittings.

⚠WARNING The RBI Flexcore is supplied with a factory installed DuraVent FastNSeal flue outlet adapter. A manufacturers supplied stainless steel transition piece must be used when installed with different vent systems. Do not mix vent systems of different manufacturers. Use only listed manufacturers (Table X), terminations (Table Y), and transition adapters (Table Z). The chimney systems manufacturer's installation instructions must be followed.

DIRECT VENT POSITIVE PRESSURE, CATEGORY IV

In this configuration the boiler blower is used to push the flue products to the outdoors while drawing combustion air from the outdoors. The INTAKE AIR OPTION instructions under the COMBUSTION AIR & VENTILATION SECTION must be followed!

Horizontal Direct Vent Systems - Figures 2 & 3

The vent materials used in positive pressure vent systems must be certified to UL 1738 for installations in the United States, ULC S636 for installations in Canada.

To maximize the performance of single wall sheet metal vent systems locate 90° elbows as far from the boiler as possible and from one another. For best results, horizontal vent systems should be as short and straight as possible.

The vent system must be both gas and water tight. All seams and joints in metal pipes must be joined and sealed in accordance with the vent system manufacturer's instructions.

When horizontal vent runs exceed **5 ft, 1.5m** they must be supported at **3 ft, 0.98 m** intervals with overhead hangers. If any part of a single wall metal vent system passes through an unheated space it must be insulated with insulation rated for **400°F, 212°C**.

Horizontal vent systems shall terminate at least **4 ft, 1.3 m** below, **4 ft, 1.3 m** horizontally from or **1 ft, 0.23 m** above any door, window or gravity air inlet into any building. It must not terminate less than **4 ft, 1.3 m** horizontally from, and in no case above or below, unless a **4 ft, 1.3 m** horizontal distance is maintained, from electric meters, gas meters, regulators and relief equipment and not less than **7 ft, 2.3 m** above adjacent public walkway.

Avoid terminal locations likely to be affected by winds, snowdrifts, people and pets. Protect building materials and vegetation from degradation caused by the flue gases.

When running horizontal combustion air and venting for single or multiple units, exhaust and combustion air terminals must be installed on the same plane (outside wall) in order to prevent pressure differences due to prevailing winds. In cold climates, double-wall or insulated inlet pipe recommended to prevent condensation.

Vertical Direct Vent Systems - see Figure 4

The vent materials used in positive pressure vent systems must be certified to UL 1738 for installations in the United States, ULC S636 for installations in Canada.

If any part of a single wall metal vent system passes through an unheated space it must be insulated with insulation rated for **400°F, 204°C**. Structural penetrations must be made using approved fire-stops.

The top of a vertical vent system must extend at least **5½ ft, 1.8 m** above the roof surface that it passes through, **4 ft, 1.3 m** above the intake air cap, see Figure 4. In addition the vent system must conform to the dimensions shown in Figure 4. The penetration point in the roof must be properly flashed and sealed.

The vent system must be gas tight. All seams and joints in metal pipes must be joined and sealed in accordance with the vent system manufacturer's instructions.

Combination Direct Vent Systems - see Figure 5

The boiler can be vented vertically with the intake air piped horizontally through an outside wall. Follow the instructions in the INTAKE AIR OPTION - HORIZONTAL GUIDELINES on page 5. Also follow the general instructions in the COMBUSTION AIR & VENTILATION and GENERAL VENTING GUIDELINES sections.

Table X- Approved Stainless Steel Vent Manufacturers (CAT II/IV)

Make	Model
DuraVent	FasNSeal Vent
M&G DuraVent	DuraSeal Vent
Heatfab	Saf-T Vent
Metal-Fab	CORR/GUARD
Security Chimneys	Secure Seal
Schebler Chimney Systems	e Vent
VAN-PACKER	CS
Z-Flex	Z-Vent
Jeremias	DWGV/SWGV
ICC	VIC

Table Y- Approved Intake/Exhaust Terminations (CAT IV - Sidewall/Horizontal Direct Vent)

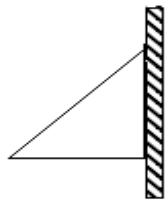
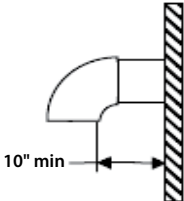
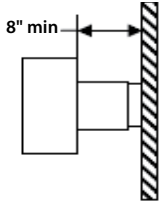
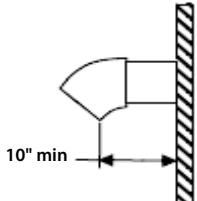
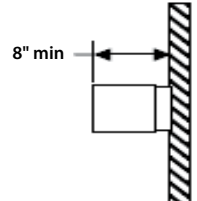
Exhaust Termination Hood	Exhaust 90 deg	Exhaust Tee	Exhaust 45 deg	Exhaust Straight
				

*with bird screen

FlexCore Stainless Steel Condensing Boilers – Installation Manual

Table Z- Approved Manufacturers Stainless Steel Boiler Transition Adapters (CAT II/IV)

Model Size	DuraVent		M&G DuraVent (DuraSeal)		ICC		Metal-Fab	
	Boiler Adapter*	Flue	Transition Adapter	Flue	Transition Adapter	Flue	Transition Adapter	Flue
1000	810013226	FasNSeal	DS5FFNSAU DSD5FFNSAUK	DS DSD	HM-5AC HM-5SDA	VIC-SW VIC-DW	No Adapter Needed	Corr/Guard
1500	810005652		DS6FFNSAU DSD6FFNSAUK		HM-6AC HM-6DSDA		6FCSLXL	
2000			DS8FFNSAU DSD8FFNSAUK		HM-8AC HM-8DSDA		8FCSLCA	
2500	810005651		DS10FFNSAU DSD10FFNSAUK		HM-10AC HM-10DSDA		10FCSPKA2	
3000			DS12FFNSAU DSD12FFNSAUK		HM-12AC HM-12DSDA		12FCSLCA	
3500	810013230							
4000								
4500								
5000	810013229							
6000								

Model Size	Heatfab (Saf-T Vent)		Security Chimneys (Secure Seal)		Jeremias		RBI	
	Transition Adapter	Flue	Transition Adapter	Flue	Transition Adapter	Flue	Boiler Adapter*	Exhaust Termination
1000	9501MAD	EZ/GC CI Plus	SS5FFNSAU SSD5FFNSAUK	SS SSD	SWG5-RCIS -	DWGV SWG	09-0002-004	09-0117
1500	9601MAD		SS6FFNSAU SSD6FFNSAUK		SWG6-RCIS -		09-0002-002	09-0112
2000			SS8FFNSAU SSD8FFNSAUK		SWG8-RCIS -		09-0002-001	09-0113
2500	9801MAD		SS10FFNSAU SSD10FFNSAUK		SWG10-RCIS -		09-0310-004	09-0115
3000	91001MAD		SS12FFNSAU SSD12FFNSAUK		SWG12-RCIS -		09-0310-005	09-0116
3500								
4000								
4500								
5000	91201MAD							
6000								

Model Size	VAN-PACKER		Z-Flex		Schebler Chimney Systems (e-Vent)	
	Transition Adapter	Flue	Transition Adapter	Flue	Transition Adapter	Flue
1000	C05VLSL/M	CS	2SVSAFNS05	Z-Flex	ESW-UNAK-05R EVD-UNAK-05R	ESW EVD
1500	C06VLSL/M		2SVSAFNS06		ESW-UNAK-06R EVD-UNAK-06R	
2000			2SVSAFNS08		ESW-UNAK-08R EVD-UNAK-08R	
2500	C08VLSL/M		2SVSAFNS10		ESW-UNAK-10R EVD-UNAK-10R	
3000	C10VLSL/M		2SVSAFNS12		ESW-UNAK-12R EVD-UNAK-12R	
3500						
4000						
4500						
5000	C12VLSL/M					
6000						

*Factory Installed

⚠ WARNING The RBI Flexcore is supplied with a factory installed DuraVent FastNSeal flue outlet adapter. A manufacturers supplied stainless steel transition piece must be used when installed with different vent systems. Do not mix vent systems of different manufacturers. Use only listed manufacturers (Table X), terminations (Table Y), and transition adapters (Table Z). The chimney systems manufacturer's installation instructions must be followed.

Figure 1 - Multiple Boiler Common Venting

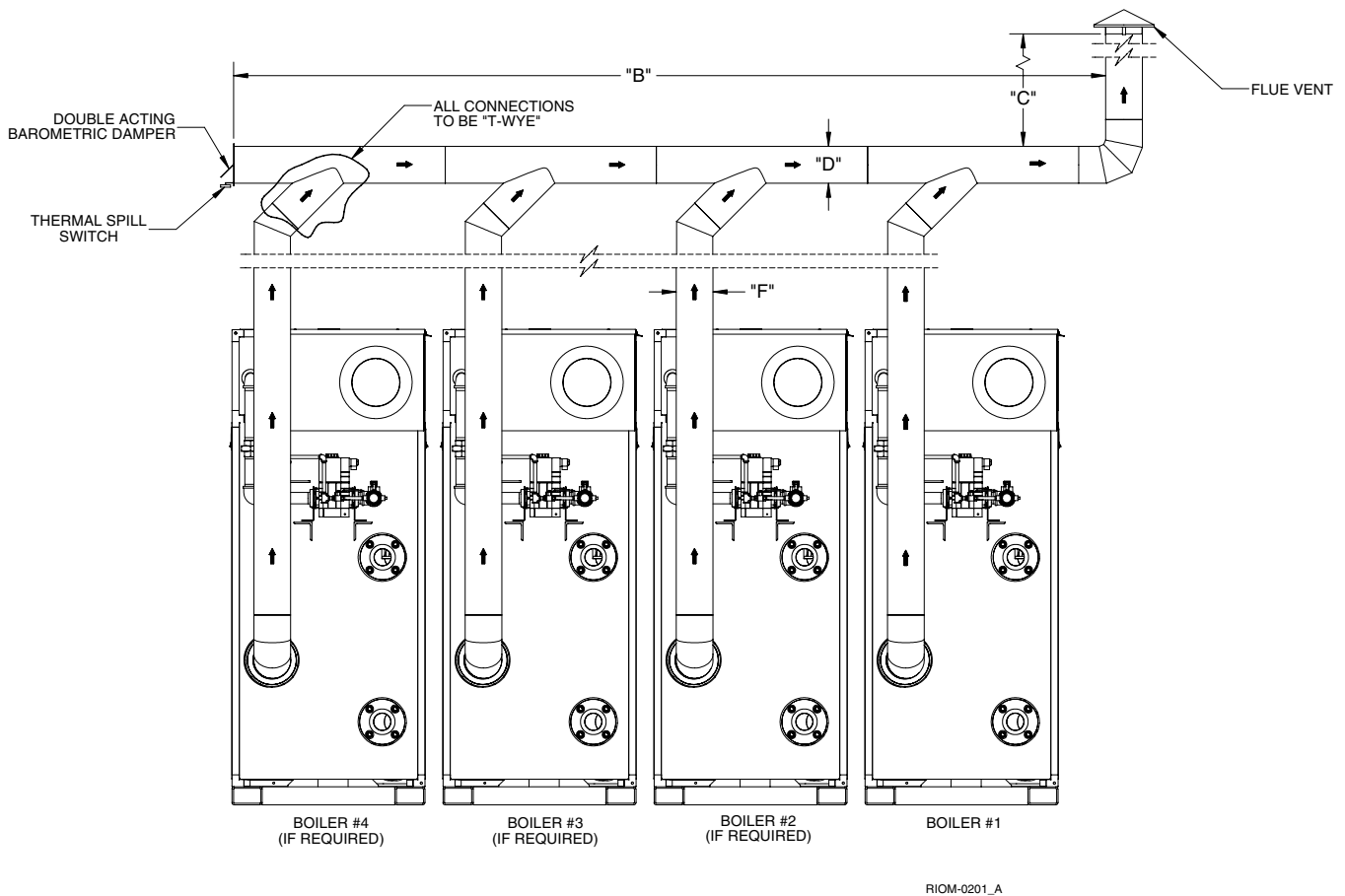

VERTICAL CHIMNEY VENTING - Vertical venting - multiple boiler installations:

⚠ WARNING It is recommended that the boiler nearest the vertical chimney be fired first when the horizontal distance exceeds 50% of the vertical distance. Refer to the HeatNet manual on how to select the lead boiler.

When sized for a (CAT II) configuration, a negative pressure of 0.02 to 0.10 inches WC is required in each boiler's riser when all boilers are operating at full input. A barometer damper must be installed as illustrated. [Exception: if the vent system is designed using accepted engineering practices, and the design calculations prove there is no need for barometric dampers, the barometric dampers may be omitted.] When required by applicable codes, install a thermal spill switch on each barometric damper.

1. Connect each boiler riser to the common vent with a Y connection or Boot T only.
2. Install an approved vent cap at each vent termination.
3. Dimensions:
 - B = breeching length
 - C = chimney height
 - D = breeching diameter
 - F = riser diameter
 - (No smaller than the dimension given in Table 4, page 6.)
4. Multi-story, common venting systems shall be in accordance with the National Fuel Gas Code, ANSI Z223.1/NFPA 54 and/ or the CSA B149.1, Natural Gas and Propane Installation Code (Current Editions), local codes and vent manufacturer's installation instructions. Size the chimney and breeching using generally accepted engineering practices. (Consult factory for vertical heights beyond 60 ft.)

Figure 2 - Horizontal Air Intake and Venting for a Single Direct Vent System

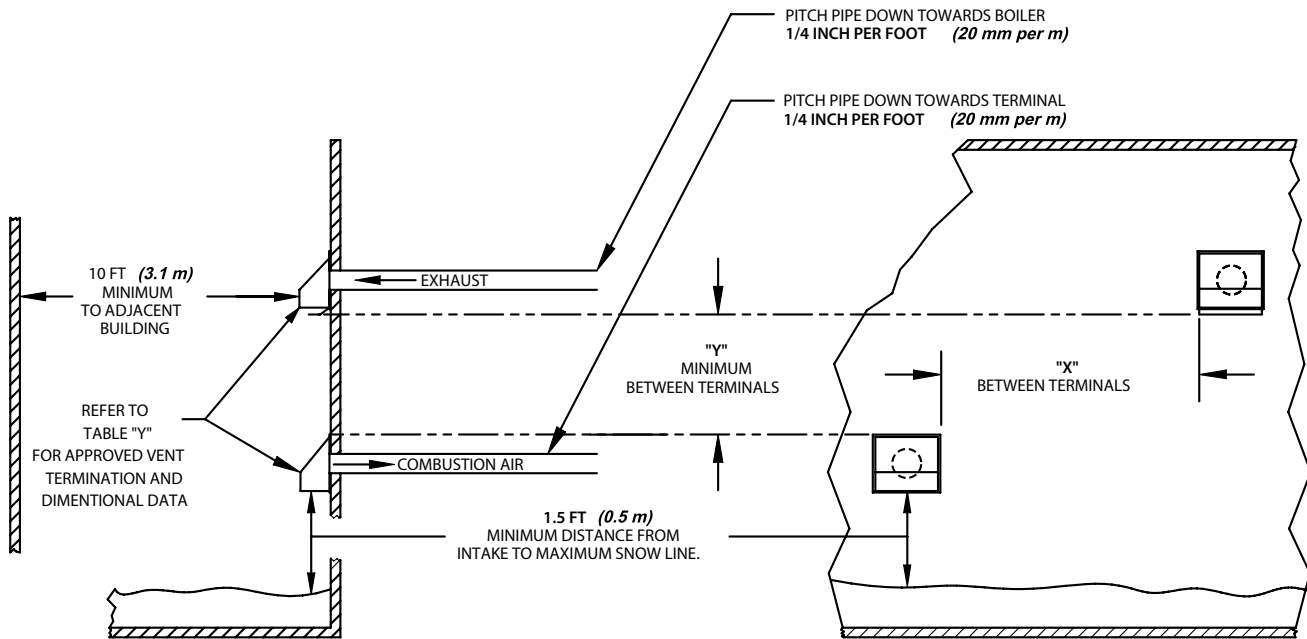

WARNING: When running horizontal combustion air and venting for single or multiple units, exhaust and combustion air terminals must be installed on the same plane (outside wall) in order to prevent pressure differences due to prevailing winds. In cold climates, double-wall or insulated inlet pipe recommended to prevent condensation.

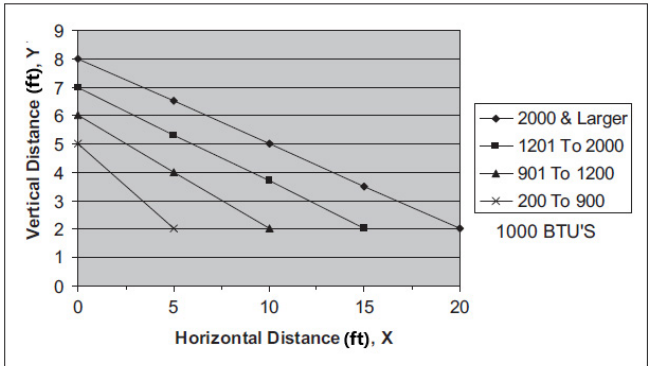

Figure 3 - Horizontal Air Intake and Venting for Multiple Direct Vent Systems

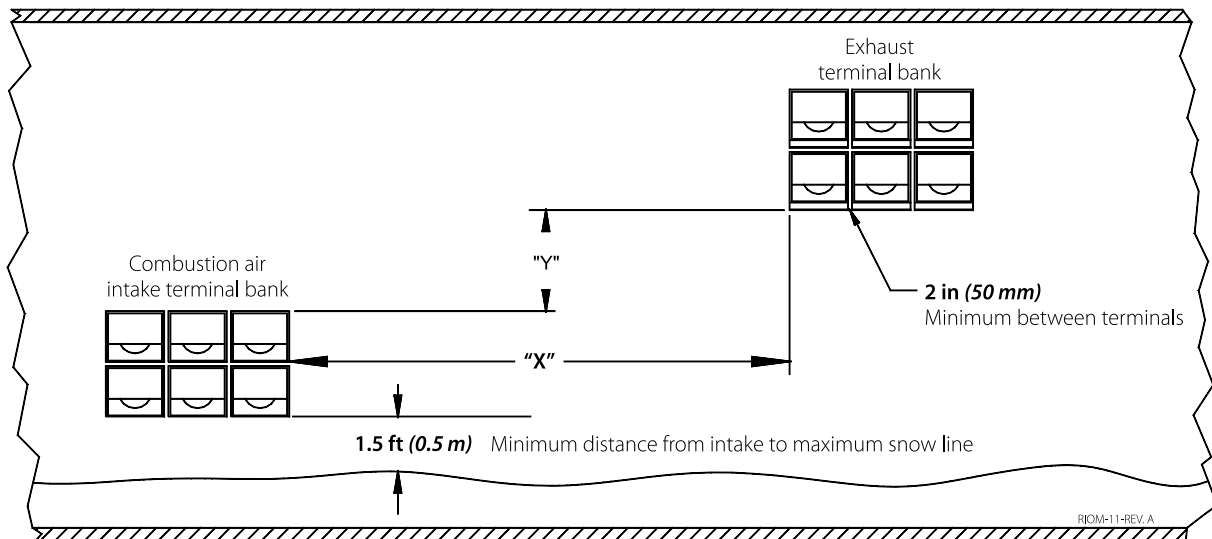

Figure 4 - Vertical Air Intake and Venting for Direct Vent System

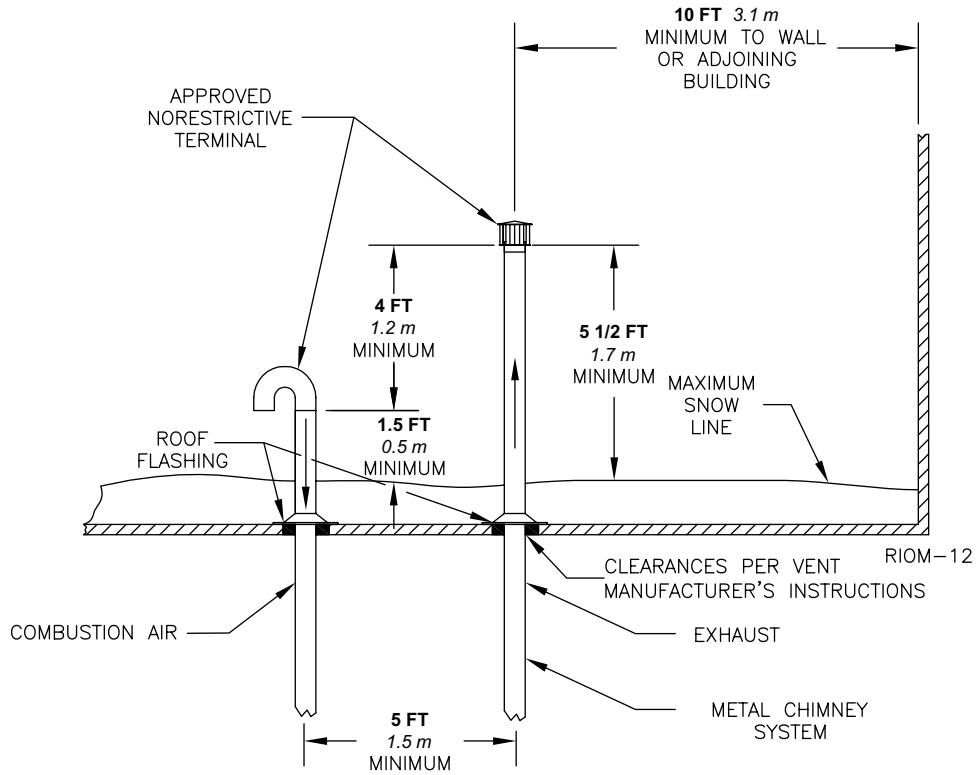
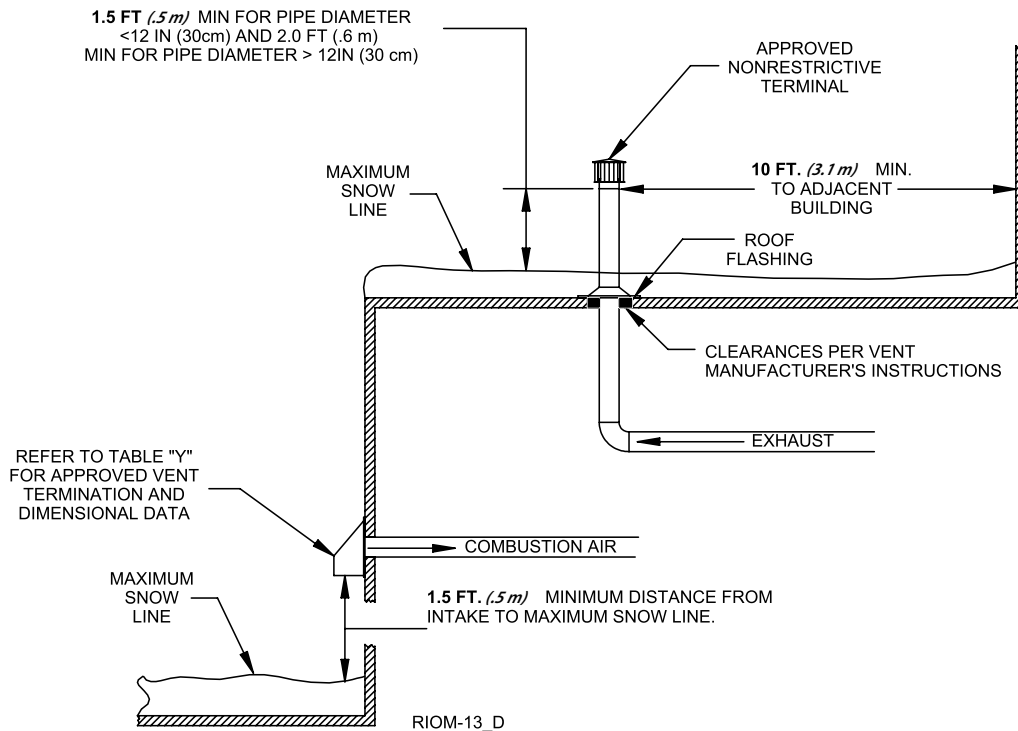

Figure 5 - Combination Direct Vent Systems



SIDE WALL VENT POSITIVE PRESSURE, CATEGORY IV

In this configuration the boiler blower is used to push the flue products horizontally to the outdoors, see Figure 6.

⚠ WARNING To ensure proper operation, boilers that are vented sidewall and use room air must not fire less than 10% input.

The air for combustion is taken from the space in which the unit is installed. The applicable instructions under the COMBUSTION AIR & VENTILATION SECTION must be followed! The vent guidelines under the HORIZONTAL DIRECT VENT SYSTEMS section must also be followed.

Figure 6 - Side Wall Venting

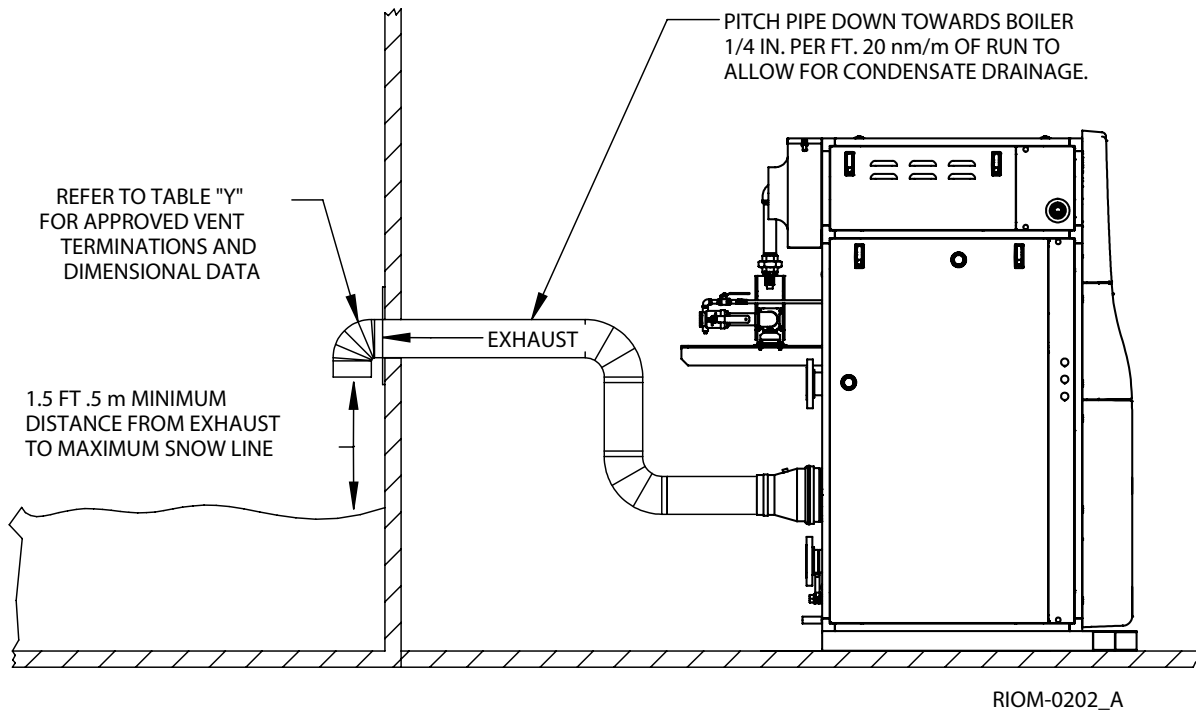

VERTICAL VENT (Recommended) POSITIVE PRESSURE - CATEGORY IV

In this configuration the boiler blower is used to push the flue products vertically to the outdoors, see Figure 7. The air for combustion is taken from the space in which the unit is installed. The applicable instructions under the COMBUSTION AIR & VENTILATION SECTION must be followed! The vent guidelines under the VERTICAL DIRECT VENT SYSTEMS section must also be followed.

Figure 7 - Vertical Positive Pressure Venting

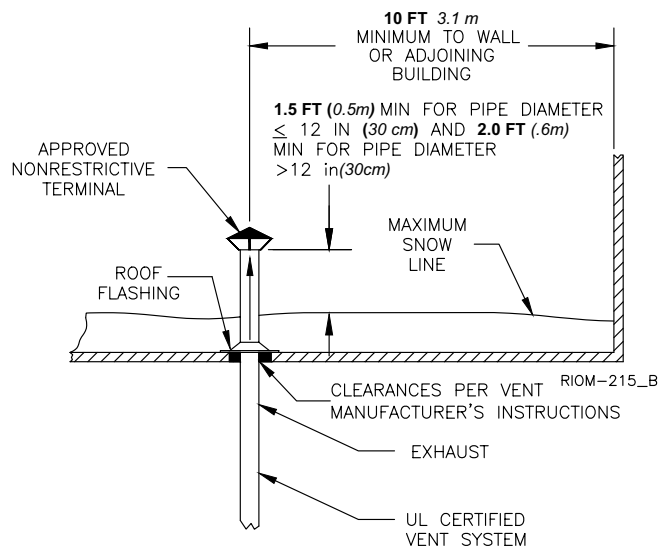

VERTICAL VENT (Optional) NEGATIVE PRESSURE - CATEGORY II

The FlexCore is listed as a Category II appliance when vented vertically into a UL 1738 listed stainless steel chimney system, Figure 8. The chimney system must provide a negative pressure of **0.02 to 0.10 in, 0.51 to 2.5 mm WC** at the boiler flue collar with the unit running.

NOTICE When using a listed metal chimney system the chimney system manufacturer’s instructions must be followed.

WARNING Multiple boiler vent systems must be designed and verified by a qualified professional and stack manufacturer. The vent system must prevent backflow of exhaust gas through idle boilers.

When more than one appliance is connected to the same chimney system the system must be large enough to safely vent the combined output of all of the appliances.

Table 5 lists the equivalent breeching and chimney sizes required for a single boiler installation.

WARNING If an appliance using any type of a mechanical draft system operating under positive pressure is connected to a chimney flue, never connect any other appliances to this flue. Doing so can result in excessive levels of carbon monoxide which can cause severe personal injury or death!

Table 5 - Minimum Riser Connection, Negative Pressure

Model Size	Breach & Flue Diameter	
	in	mm
1000	8	204
1500	8	204
2000	10	254
2500	12	305
3000	12	305
3500	14	356
4000	14	356
4500	14	356
5000	16	406
6000	16	406

NOTICE Vent system must be sized per an engineered system.

Vent Connections

Locate the boiler as close to the chimney system as possible. Use the shortest, straightest vent connector possible for the installation. If horizontal runs exceed **5 ft, 1.5 m** they must be supported at **3 ft, 0.9 m** intervals with overhead hangers. Use the appropriate vent connector of the same diameter as the flue collar to connect the boiler to a listed metal chimney system. Follow the chimney system manufacturer’s instructions for proper assembly.

The vent system should be sloped up toward the chimney at a minimum rate of **1/4 in/ft, 2 cm/m**.

Always provide a minimum clearance of **6 in, 152 mm** between single wall vent pipe and any combustible materials.

WARNING Failure to maintain minimum clearances between vent connectors and any combustible material can result in a fire causing extensive property damage, severe personal injury or death!

Exit cones are favorable when used to increase the velocity of the flue gas exiting the stack and, may also help, in cold climates, to reduce ice build-up. Exit cone terminations must be supplied by others, installed per manufacturer’s instructions, and meet local and federal code.

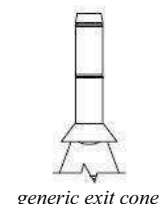

generic exit cone

Figure 8 - Vertical Venting with a Metal Chimney System

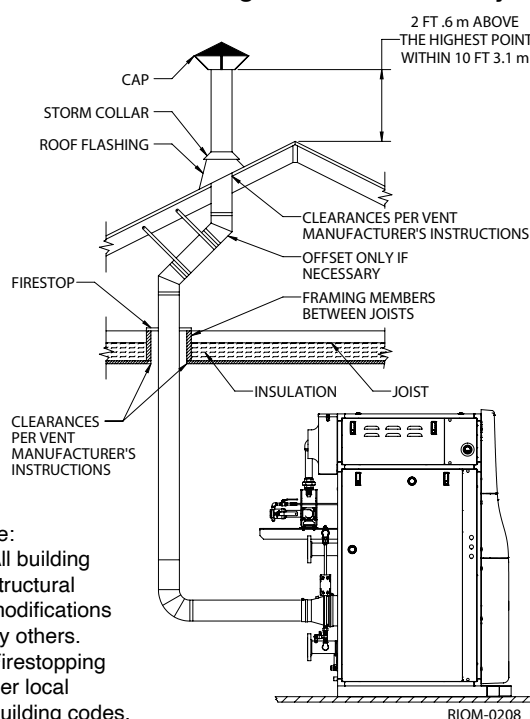

- Note:
- 1) All building structural modifications by others.
 - 2) Firestopping per local building codes.

EXISTING COMMON VENT SYSTEMS

If an existing boiler is removed from a common venting system, the common venting system may then be too large for the proper venting of the remaining appliances connected to it. At the time of removal of an existing boiler, the following steps shall be followed with each appliance remaining connected to the common venting system placed in operation, while the other appliances remaining connected to the common venting system are not in operation.

- a) Seal any unused openings in the common venting system.
- b) Visually inspect the venting system for proper size and horizontal pitch and determine there is no blockage or restriction, leakage, corrosion and other deficiencies which could cause an unsafe condition.
- c) Insofar as is practical, close all building doors and windows and all doors between the space in which the appliances remaining connected to the common venting system are located and other spaces of the building. Turn on clothes dryers and any appliance not connected to the common venting system. Turn on any exhaust fans, such as range hoods and bathroom exhaust, so they will operate at maximum speed. Do not operate a summer exhaust fan for a boiler installation. Close fireplace dampers.
- d) Place in operation the appliance being inspected. Follow the lighting instructions. Adjust thermostat so appliance will operate continuously.
- e) After it has been determined that each appliance remaining connected to the common venting system properly vents when tested as outlined above, return doors, windows, exhaust fans, fireplace dampers and any other gas-burning appliance to their previous condition of use.
- f) Any improper operation of the common venting system should be corrected so the installation conforms with the National Fuel Gas Code, ANSI Z223.1/NFPA 54. When resizing any portion of the common venting system, the common venting system should be resized to approach the minimum size as determined using the appropriate tables in Appendix F in the National Fuel Gas Code, ANSI Z223.1/ NFPA 54 and or CSA B149 Installation Codes.

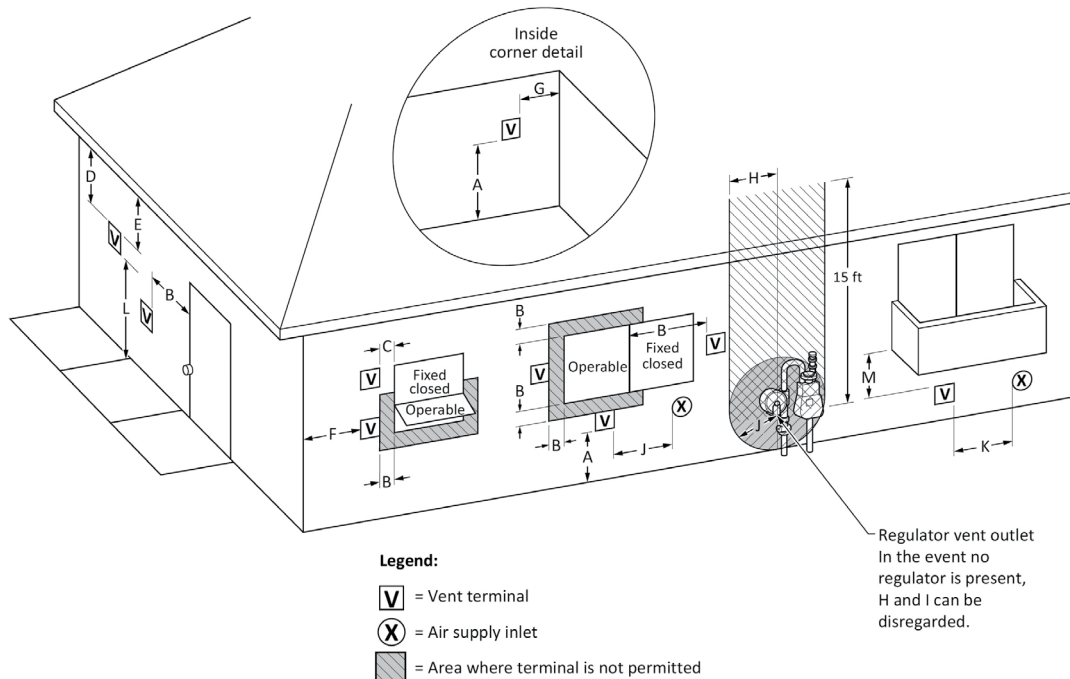

Figure A - Direct Vent Terminal Clearances

		Canadian Installations¹	US Installations²
A =	Clearance above grade, veranda, porch, deck, or balcony	12 in (30 cm)	12 in (30 cm)
B =	Clearance to window or door that may be opened	6 in (15 cm) for appliances ≤ 10,000 Btuh (3 kW); 12 in (30 cm) for appliances > 10,000 Btuh (3 kW) and ≤ 100,000 Btuh (30 kW); 36 in (91 cm) for appliances > 100,000 Btuh (30 kW)	6 in (15 cm) for appliances ≤ 10,000 Btuh (3 kW); 9 in (23 cm) for appliances > 10,000 Btuh (3 kW) and ≤ 50,000 Btuh (15 kW); 12 in (30 cm) for appliances > 50,000 Btuh (15 kW)
C =	Clearance to permanently closed window	Per local installation codes	
D =	Vertical clearance to ventilated soffit located above the terminal within a horizontal distance of 2 ft (61 cm) from the center line of the terminal.		
E =	Clearance to unventilated soffit		
F =	Clearance to outside corner		
G =	Clearance to inside corner		
H =	Clearance to each side of center line extended above meter / regulator assembly	3 ft (91 cm) within a height of 15 ft (4.6m)	
I =	Clearance to service regulator vent outlet	3 ft (91 cm)	
J =	Clearance to nonmechanical air supply inlet to building or the combustion air inlet to any other appliance	6 in (15 cm) for appliances ≤ 10,000 Btuh (3kW); 12 in (30 cm) for appliances > 10,000 Btuh (3 kW) and ≤ 100,000 Btuh (30 kW); 36 in (91 cm) for appliances > 100,000 Btuh (30 kW)	6 in (15 cm) for appliances ≤ 10,000 Btuh (3kW); 9 in (23 cm) for appliances > 10,000 Btuh (3 kW) and ≤ 50,000 Btuh (15 kW); 12 in (30 cm) for appliances > 50,000 Btuh (15 kW)

FlexCore Stainless Steel Condensing Boilers – Installation Manual

Figure A - Direct Vent Terminal Clearances - Concluded

K =	Clearance to a mechanical air supply inlet	6 ft (1.83 m)	3 ft (91 cm) above if within 10 ft (3 m) horizontally
L =	Clearance above paved sidewalk or paved driveway located on public property	7 ft (2.13 m)†	Vents for Category II and IV appliances cannot be located above public walkways or other areas where condensate or vapor can cause a nuisance or hazard
M =	Clearance under veranda, porch, deck, or balcony	12 in (30 cm)‡	Per local installation codes
†	A vent shall not terminate directly above a sidewalk or paved driveway that is located between two single family dwellings and serves both dwellings.		
‡	Permitted only if veranda, porch, deck, or balcony is fully open on a minimum of two sides beneath the floor.		
NOTES:			
1)	In accordance with the current CSA B149.1, Natural Gas and Propane Installation Code		
2)	In accordance with the current ANSI Z223.1/NFPA 54, National Fuel Gas Code		
3)	If locally adopted installation codes specify clearances different than those illustrated, then the most stringent clearances must prevail.		

Figure A - Other Than Direct Vent Terminal Clearances

		Canadian Installations¹	US Installations²
A =	Clearance above grade, veranda, porch, deck, or balcony	12 in (30 cm)	12 in (30 cm)
B =	Clearance to window or door that may be opened	6 in (15 cm) for appliances ≤ 10,000 Btuh (3 kW); 12 in (30 cm) for appliances > 10,000 Btuh (3 kW) and ≤ 100,000 Btuh (30 kW); 36 in (91 cm) for appliances > 100,000 Btuh (30 kW)	4 ft (1.2 m) below or to side of opening; 1 ft (300 mm) above opening
C =	Clearance to permanently closed window	Per local installation codes	
D =	Vertical clearance to ventilated soffit located above the terminal within a horizontal distance of 2 ft (61 cm) from the center line of the terminal		
E =	Clearance to unventilated soffit		
F =	Clearance to outside corner		
G =	Clearance to inside corner		
H =	Clearance to each side of center line extended above meter/regulator assembly	3 ft (91 cm) within a height of 15 ft (4.6m)	
I =	Clearance to service regulator vent outlet	3 ft (91 cm)	
J =	Clearance to nonmechanical air supply inlet to building or the combustion air inlet to any other appliance	6 in (15 cm) for appliances ≤ 10,000 Btuh (3kW); 12 in (30 cm) for appliances > 10,000 Btuh (3 kW) and ≤ 100,000 Btuh (30 kW); 36 in (91 cm) for appliances > 100,000 Btuh (30 kW)	4 ft (1.2 m) below or to side of opening; 1 ft (300 mm) above opening

Figure A - Other Than Direct Vent Terminal Clearances - Concluded

K =	Clearance to a mechanical air supply inlet	6 ft (1.83 m)	3 ft (91 cm) above if within 10 ft (3 m) horizontally
L =	Clearance above paved sidewalk or paved driveway located on public property	7 ft (2.13 m)†	Vents for Category II and IV appliances cannot be located above public walkways or other areas where condensate or vapor can cause a nuisance or hazard
M =	Clearance under veranda, porch, deck, or balcony	12 in (30 cm)‡	Per local installation codes

† A vent shall not terminate directly above a sidewalk or paved driveway that is located between two single family dwellings and serves both dwellings.

‡ Permitted only if veranda, porch, deck, or balcony is fully open on a minimum of two sides beneath the floor.

NOTES:

- 1) In accordance with the current CSA B149.1, Natural Gas and Propane Installation Code
- 2) In accordance with the current ANSI Z223.1/NFPA 54, National Fuel Gas Code
- 3) If locally adopted installation codes specify clearances different than those illustrated, then the most stringent clearances must prevail.

GENERAL PIPING REQUIREMENTS

CAUTION Improper piping of this boiler will void the manufacturer’s warranty and can cause boiler failure resulting in flooding and extensive property damage!

NOTICE Shut off valves and unions should be installed at the inlet and outlet connections of the boiler to provide for isolation of the unit should servicing be necessary.

Relief Valve

Pipe the discharge of the pressure relief valve (Figure 9) per the "Heating System Piping/General Piping Requirements Section.

CAUTION Never install any type of valve between the boiler and the relief valve or an explosion causing extensive property damage, severe personal injury or death may occur!

Freeze Protection

Installations in areas where the danger of freezing exists are not recommended unless proper freeze protection is provided. The following precautions **MUST** be observed:

1. A continuous flow of water through the unit **MUST** be maintained! The pump responsible for flow through the boiler must run continuously!
2. A polypropylene glycol/water mixture suitable for the minimum temperature that the unit will be exposed to must be used. The pump must be capable of producing a minimum of 15% more flow and overcoming a 20% increase in head loss. Domestic water systems must be isolated from the boiler by the use of a heat exchanger or other approved method.
3. If the unit must be shut off for any reason the electric, gas and water supplies **MUST** be shut off and the unit and its pump completely drained.

Figure 9 - FlexCore Firetube Piping

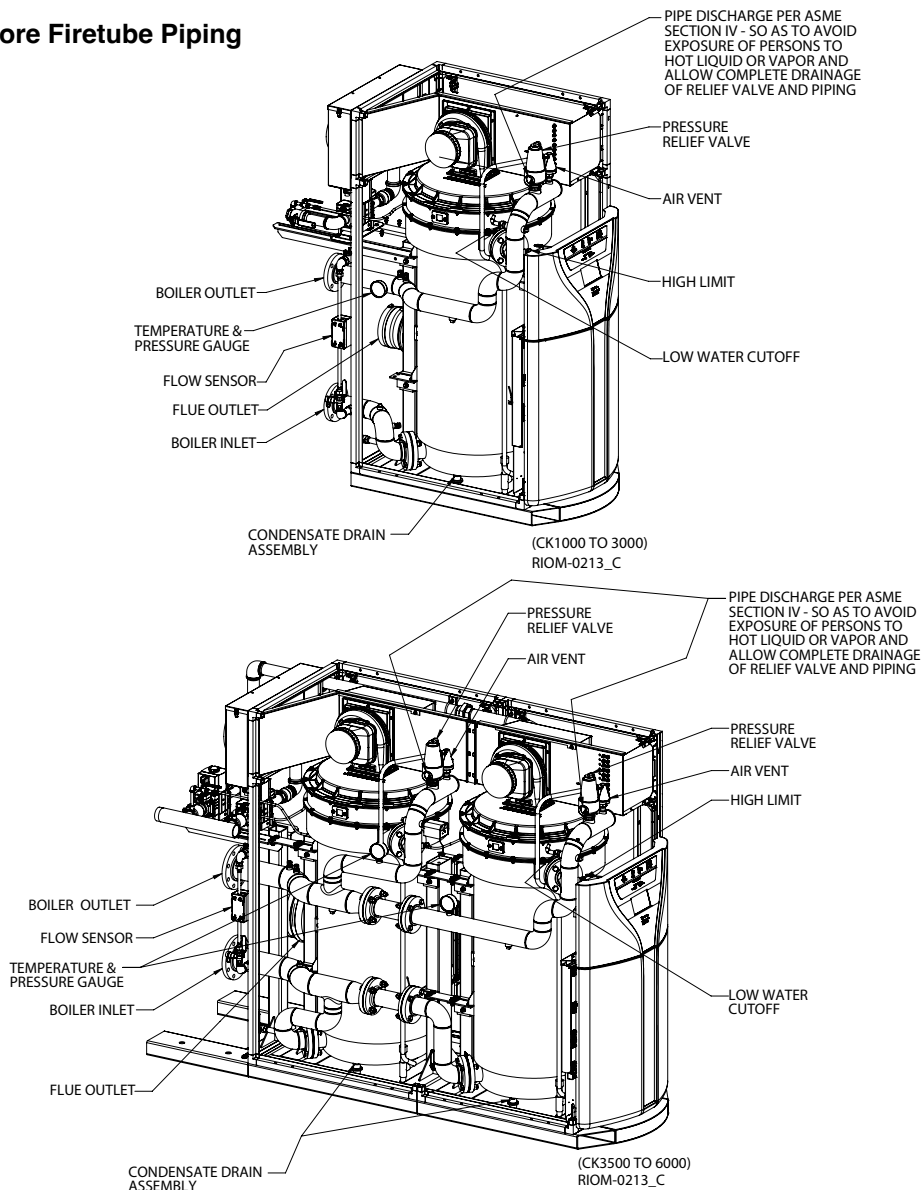

Flow Sensor

The factory mounted SIKA flow sensor, as shown in Figure 9, is wired to prevent the boiler from firing unless there's adequate water flow, Table 6, through the unit.

NOTICE The SIKA flow sensor sends information to the HeatNet control and displays the water flow information in (gpm). The minimum flow settings are fully adjustable. The boiler will not operate if the (gpm) falls below the minimum value. If the system is using Glycol the % of glycol mixture must be entered. The SIKA Flow sensor is limited to **194°F**, 90°C water temperature, 145 psi operating pressure and a 50% glycol mixture. If the return water temperature rises above **194°F**, 90°C the boiler will shut down. For applications outside these requirements, please consult Manufacturer. Reference the HeatNet IOM for menu instructions.

Air Vent

The factory mounted air vent, as shown in Figure 9, is installed to automatically purge unwanted air from the boiler allowing the system to run more effectively.

NOTICE Please note that after installing in a new system or retrofitting an old, close the isolation valve installed upstream of the Air Vent prior to filling the system with water. Once the system has been properly filled open the Air Vent isolation valve for automatic operation. If this is not done, it is entirely possible that the internal float mechanism will become clogged open, causing the air vent to leak.

Table 6 - Temperature Rise Table

Model Size	Water Flow Rates (GPM)		
	100%-Input		10%-Input
	Min. *	Max. *	Min.
1000	19.1	95.5	19.1
1500	28.5	142.7	20.4
2000	38.0	190.2	25.4
2500	48.0	239.8	32.0
3000	58.1	290.5	38.7
Model Size	100%-Input		20%-Input
	Min. *	Max. *	Min.
	3500	66.6	332.9
4000	76.1	380.4	50.7
4500	86.6	433.1	57.7
5000	95.9	479.7	64.0
6000	116.2	581.0	77.5

*Min/Max flow correspond to a (20°F/100°F) Δt at full input. Verify system pipe sizing allows for flow velocity requirements.

NOTICE In order to maintain boiler capacity, increase flow rates approximately (10%) and pump head (25%) for mixtures up to 50% glycol.

NOTICE Use the following equation to determine the boiler derate capacity when adjustments aren't made. (2012 ASHRAE Systems Handbook)

Where $qw = 500 * Q * (p/pw) * Cp * \Delta T$

qw = Total heat transfer rate, BTU/h Q = flow rate, gpm
 p = fluid density, lb/ft³ pw = density of water at 60°F, lb/ft³
 Cp = specific heat of fluid, Btu/lb °F ΔT = temperature difference, °F

HEATING SYSTEM PIPING

General Piping Requirements

All heating system piping must be installed by a qualified technician in accordance with the latest revision of the ANSI/ASME Boiler and Pressure Vessel Code, Section IV.

Where required, the piping must comply with ANSI/ASME CSD-1, Standard for Controls and Safety Devices for Automatically Fired Boilers.

All applicable local codes and ordinances must also be followed. A minimum clearance of **1in**, 25 mm must be maintained between heating system pipes and all combustible construction. All heating system piping must be supported by suitable hangers, not the boiler. The thermal expansion of the system must be considered when supporting the system. A minimum system pressure of **20 psig**, 138 kPa must be maintained at boiler operating conditions. For glycol systems, a minimum system pressure of **30 psig**, 207 kPa must be maintained at boiler operating conditions.

NOTICE When equipped with a boiler pressure transducer, pressure will be monitored closely for increased protection. A warning and/or alarm will be detected when conditions fall below the following parameters:

- Warning (boiler water) - pressure < 18 psi
- Warning (boiler water/glycol mix) - pressure < 28 psi
- Alarm - pressure < 15 psi

Boiler Piping Connections

The supply and return connections should be sized to suit the system, see Table 7.

Table 7 - Supply & Return Pipe Connection

Model Size	Supply Size	Return Size
1000	3" NPT	3" NPT
1500	3" NPT	3" NPT
2000	3" NPT	3" NPT
2500	3" NPT	3" NPT
3000	3" NPT	3" NPT
3500	4" NPT	4" NPT
4000	4" NPT	4" NPT
4500	4" NPT	4" NPT
5000	4" NPT	4" NPT
6000	4" NPT	4" NPT

CAUTION System Cleaning & Flushing: Prior to commissioning the boiler(s), the piping/system must be cleaned and flushed to prevent contaminants from settling back into the boiler and fouling the heat exchanger.

Isolate the boiler from the system prior to the cleaning process. Fill the system with water, add the cleaning solution and follow the solution manufacturer's instructions. Once clean, refill the system with clean water as specified in the Water Treatment section.

Water Treatment

This boiler was designed to operate in a closed loop heating system. System fill water must not contain more than 500 ppm of total dissolved solids, less than 150 ppm chloride concentration and no greater than 300 ppm hardness. Suspended solids such as Magnetite, Iron Oxides must be flushed from the system prior to commissioning the boiler(s). The PH level must be within the 6.5-10 range. Where required, the system must be protected by the addition of a corrosion inhibitor per the chemical supplier's instructions.

For systems requiring glycol for freeze protection use a glycol/water mix that prevents foaming. Air entrapped within foam significantly decreases heat transfer and can result in damage to the heat exchanger. Products such as DOWFROST, DOWTHERM, UCARTHERM or an equivalent product must be used to ensure proper protection to the boiler.

The water used for dilution of concentrated heat transfer fluids must be distilled, de-ionized, or equivalently clean as stated above. De-ionized water by itself can be aggressive towards many metals, but is perfectly safe when used for dilution of DOWFROST, DOWTHERM or UCARTHERM as specified by the manufacturer.

FAILURE TO ENSURE PROPER WATER QUALITY CAN RESULT IN DAMAGE TO THE BOILER(S) VOIDING THE WARRANTY.

Water Meter

Make-up water introduced into a closed system due to system leaks can negatively affect the long term reliability of the heating system resulting in abnormal boiler water quality. It is recommended that a water meter be installed in the system make-up line. If make-up is recorded, the leaks must be found and repaired.

Pump Requirements

This boiler requires a continuous minimum water flow for proper operation. The system pump must be sized to overcome the head loss of the boiler and the heating system in order to achieve the required temperature rise. If the system contains hydronic antifreeze this must be considered when sizing the pump. The temperature rise across the boiler must never exceed **100°F, 55.6°C**.

Low Water Cutoff

Each boiler comes equipped with a factory installed low water cutoff.

Expansion Tank & Air Separator

An expansion tank or other means to control thermal expansion must be installed in the heating system. It is recommended the expansion tank is installed close to the suction side of the pump. Coalescing style air separators are required in Variable Speed Systems where velocities can vary and maybe too slow for conventional type air separators. Failure to follow these guidelines will result in

poor system performance with minimal air removal and may void the factory warranty.

Reverse Return Piping

Systems using multiple boilers can also be installed using a reverse return system, Figure 11.

Primary/Secondary Piping (RECOMMENDED)

Figure 12 shows a typical single and multiple boiler primary/secondary piping system. A dedicated pump is used to maintain a constant water flow through the boiler. Flow must be properly accounted for in the design of primary/secondary systems. In order to prevent boiler(s) from short cycling, the system flow must be equal to or higher than the boiler(s) local flow, (Figure 12). A hydraulic separator is designed to decouple the boiler flow from the system flow, (Figure 13). In cases when minimum boiler output exceeds system demand additional water volume may be required to maximize runtime. This can be accomplished with additional volume in form of a buffer tank or utilizing a hybrid buffer tank/hydraulic separator combination or a three-way valve at the end of a main piping loop to provide system water volume to allow a minimum of 10 minutes run time at minimum load conditions.

NOTICE When required, use the following equation to determine the Buffer Tank capacity at the desired run time (10 min runtime recommended).

$$\text{Buffer Tank Volume} = (\text{Desired Runtime} \times (\text{Minimum Boiler Output} - \text{Minimum System Load})) / (\text{Temperature Differential} \times 8.33 \times 60)$$

Where:

Buffer Tank Volume, (gal)

Desired Runtime, (min)

Minimum Boiler Output, (BTU/HR)

Minimum System Load, (BTU/HR)

Temperature Differential = (system supply - system return)

8.33 = weight of water, (lb/gal)

60 = (min/hr)

Piping For Use With Cooling Units

The boiler, when used in connection with a refrigeration system, must be installed so the chilled medium is piped in parallel with the boiler. Appropriate valves must be used to prevent the chilled water from entering the boiler.

When a boiler is connected to a heating coil that may be exposed to refrigerated air from an air handling device, the piping system must be equipped with flow-control valves or some other automatic means of preventing gravity circulation of the boiler water during the cooling cycle.

NOTICE It is essential that following boiler shut off, the boiler pump continue to operate for approximately (5) minutes to dissipate the heat away from the heat exchanger.

Figure 10 - Typical Single Boiler Piping
(Circulator pump **must** be sized for minimum water flow rate of boiler, including system pressure drop)

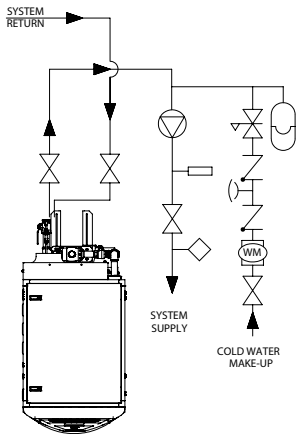
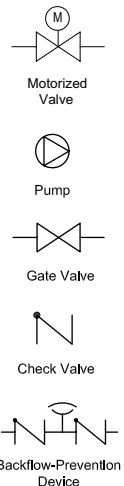
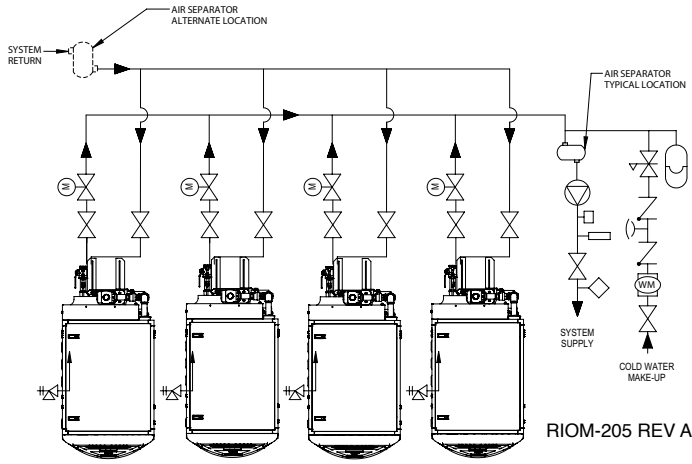
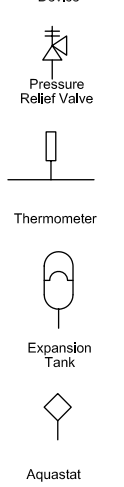
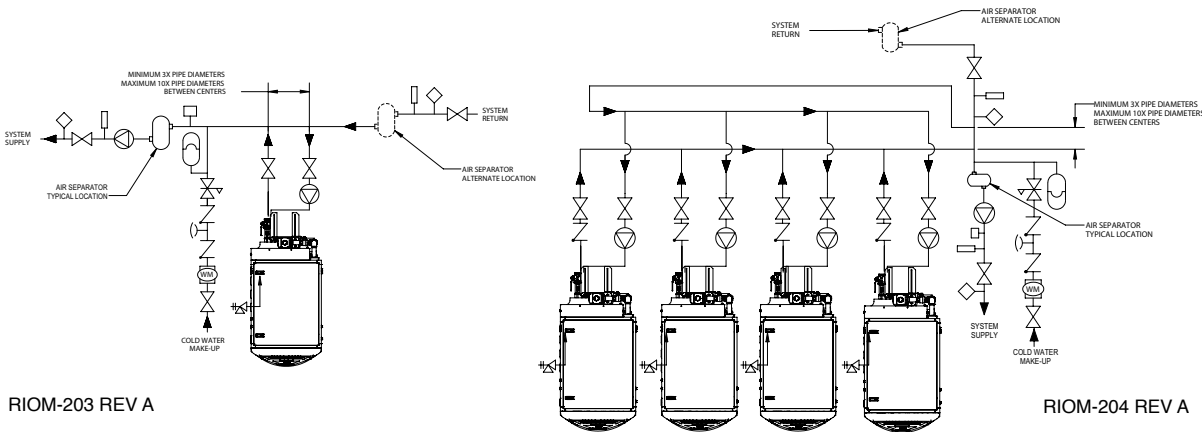

Figure 11 - Typical Multiple Boiler Reverse Return Piping
(Careful consideration as to minimum boiler and system water flow rates must be taken. Please consult our local manufacturers representative for assistance.)



NOTE: Not all system valves may be shown. Consult local codes for additional system components which may be necessary. For HeatNet operation, a sensor is required and installed at a minimum of 12" from primary loop tee.

Figure 12 - Typical Single & Multiple Boiler Primary/Secondary Piping



NOTE: Not all system valves may be shown. Consult local codes for additional system components which may be necessary. For HeatNet operation, a sensor is required and installed at a minimum of 12" from primary loop tee.

Figure 13 - Typical Multiple Boiler Primary/Secondary Piping - Hydraulic Separator (RECOMMENDED)

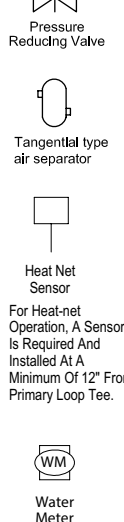
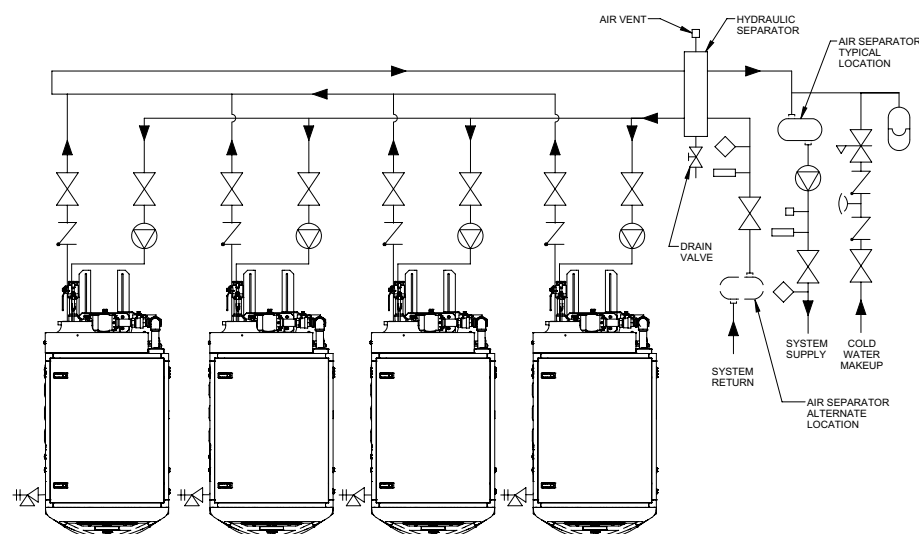

NOTE: Not all system valves may be shown. Consult local codes for additional system components which may be necessary. For HeatNet operation, a sensor is required and installed at a minimum of 12" from primary loop tee. For optimum results, the hydraulic separator must be sized per the manufacturers entering velocity requirements.

DOMESTIC WATER SUPPLY PIPING

CAUTION Proper controls must be used to prevent water supplied for domestic use from exceeding **130°F, 54°C** or a scald injury will occur! When higher water temperatures are required for appliances such as a dishwasher, a mixing valve or some other tempering means must be installed. Households with small children may require water temperatures less than **120°F, 49°C**. Local codes must be complied with!

General Piping Requirements

The FlexCore boiler can be used in combination with an indirect tank to provide hot water for domestic use. Piping and components must be suitable for use with potable water. The indirect storage tank must be equipped with a temperature and pressure relief valve that complies with ANSI Z21.22 or CAN-4.4 and CAN-4.6.

NOTICE The storage tank must be located as close to the boiler as possible to prevent excessive head loss which will reduce flow.

Expansion Tank

An expansion tank or other means to control thermal expansion must be installed in the water heating system if back flow prevention devices are installed.

Two typical water heating systems are shown in Figures 14 & 15.

Thermostatic Mixing Valve- Water Above 140°F, 60°C

Water can be stored at temperatures above **140°F, 60°C** provided that a thermostatically controlled mixing valve is used to temper the hot water to an acceptable temperature before it's supplied for domestic use. The mixing valve **MUST** be set to prevent a scald injury from occurring, see the caution against scalding above. Storage of water for domestic use above **140°F, 60°C** will provide an increased quantity of tempered water and help prevent the growth of water born bacteria.

Figure 14 - Typical Single Boiler with Indirect Storage Tank Piping

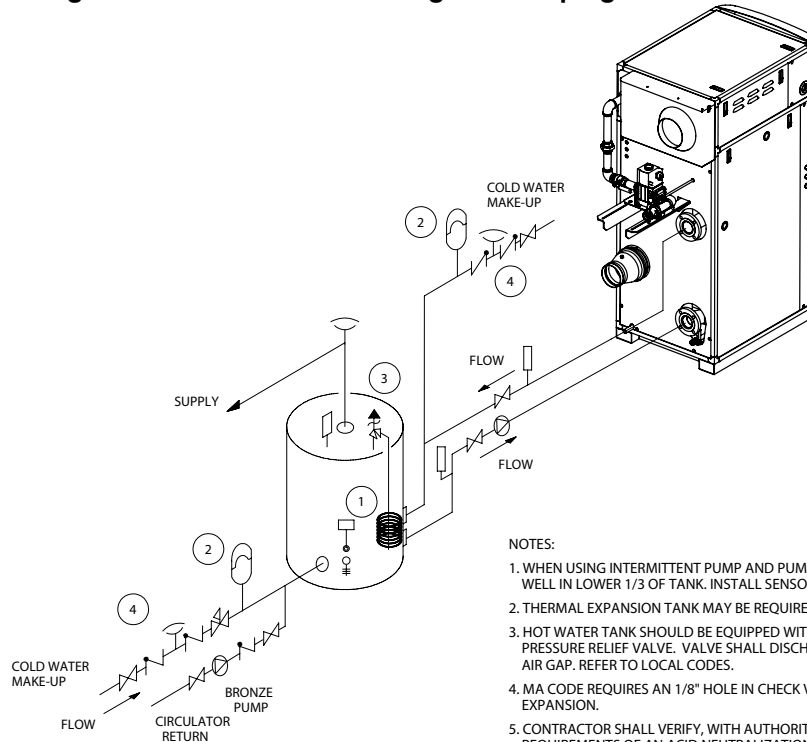

NOTES:

1. WHEN USING INTERMITTENT PUMP AND PUMP DELAY, LOCATE HEAT NET SENSOR WITH WELL IN LOWER 1/3 OF TANK. INSTALL SENSOR WITH HEAT SENSING COMPOUND.
2. THERMAL EXPANSION TANK MAY BE REQUIRED, CHECK LOCAL CODES.
3. HOT WATER TANK SHOULD BE EQUIPPED WITH A COMBINATION TEMPERATURE & PRESSURE RELIEF VALVE. VALVE SHALL DISCHARGE TO A SAFE PLACE WITH AN AIR GAP. REFER TO LOCAL CODES.
4. MA CODE REQUIRES AN 1/8" HOLE IN CHECK VALVES TO COMPENSATE FOR THERMAL EXPANSION.
5. CONTRACTOR SHALL VERIFY, WITH AUTHORITY HAVING JURISDICTION, FOR THE REQUIREMENTS OF AN ACID NEUTRALIZATION KIT.
6. A THERMOSTATIC MIXING VALVE MAY BE REQUIRED AT THE OUTLET OF THE TANK IN ORDER TO LIMIT THE MIXED WATER TO A DESIRABLE TEMPERATURE HELPING TO PREVENT SCALDING AND INJURY. CONSULT LOCAL CODES.

NOTICE: THESE DRAWINGS SHOW SUGGESTED PIPING CONFIGURATION, VALVING AND ARE DIAGRAMMATIC. CHECK WITH LOCAL CODES AND ORDINANCES FOR SPECIFIC REQUIREMENTS.



Figure 15 - Typical Multiple Boiler with Indirect Storage Tank Piping

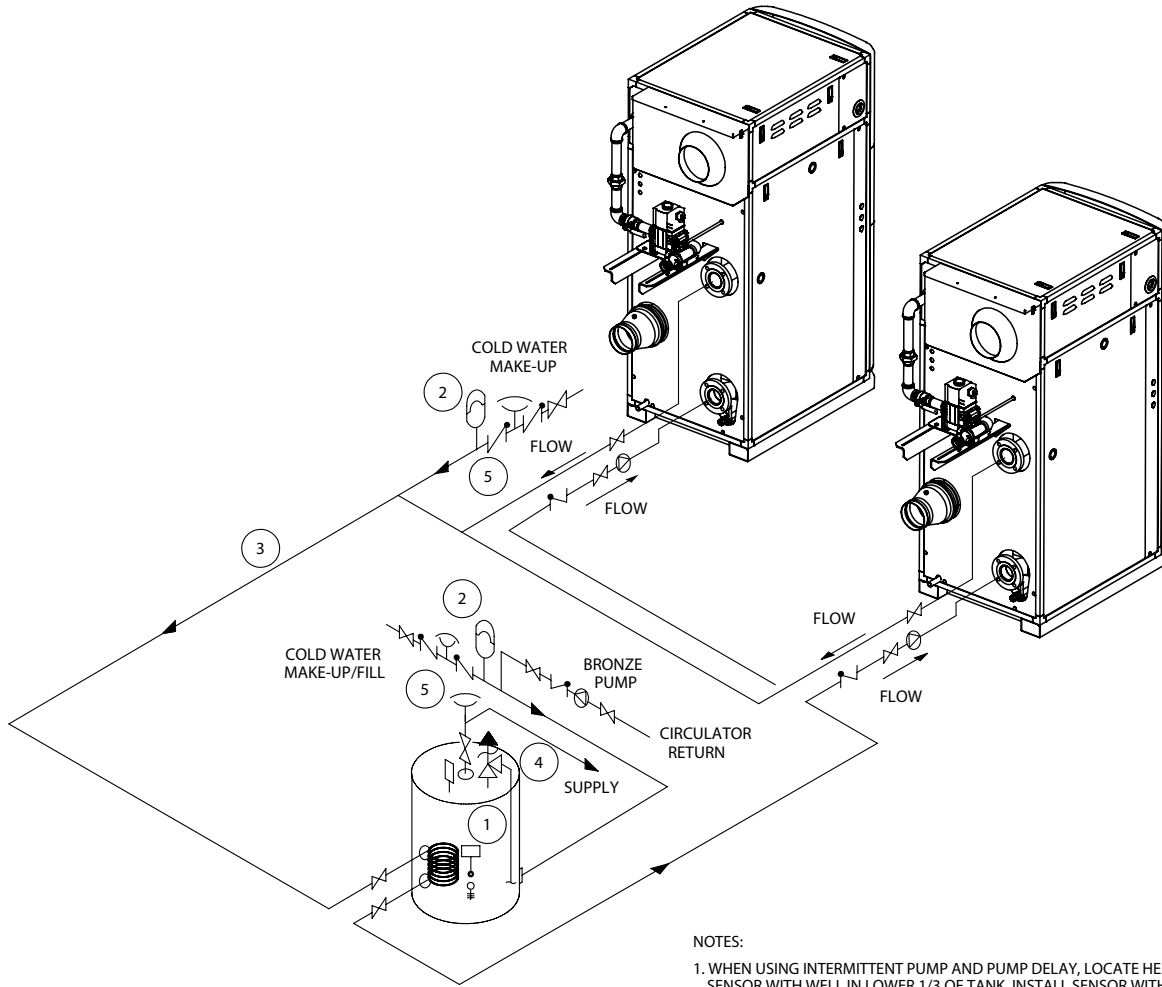

NOTES:

1. WHEN USING INTERMITTENT PUMP AND PUMP DELAY, LOCATE HEAT NET SENSOR WITH WELL IN LOWER 1/3 OF TANK. INSTALL SENSOR WITH HEAT SENSING COMPOUND.
2. THERMAL EXPANSION TANK MAY BE REQUIRED, CHECK LOCAL CODES.
3. COMMON PIPING MUST BE SIZED FOR MAXIMUM COMBINED HEATER FLOW.
4. HOT WATER TANK SHOULD BE EQUIPPED WITH A COMBINATION TEMPERATURE & PRESSURE RELIEF VALVE. VALVE SHALL DISCHARGE TO A SAFE PLACE WITH AN AIR GAP. REFER TO LOCAL CODES.
5. CONTRACTOR SHALL VERIFY, WITH AUTHORITY HAVING JURISDICTION, FOR THE REQUIREMENTS OF AN ACID NEUTRALIZATION KIT.
6. A THERMOSTATIC MIXING VALVE MAY BE REQUIRED AT THE OUTLET OF THE TANK IN ORDER TO LIMIT THE MIXED WATER TO A DESIRABLE TEMPERATURE HELPING TO PREVENT SCALDING AND INJURY. CONSULT LOCAL CODES.

NOTICE: THESE DRAWINGS SHOW SUGGESTED PIPING CONFIGURATION, VALVING AND ARE DIAGRAMMATIC. CHECK WITH LOCAL CODES AND ORDINANCES FOR SPECIFIC REQUIREMENTS.



RIOM-0207_A

CONDENSATE PIPING

The condensate trap provided with the boiler must be attached to the bottom pan and piped to a suitable floor drain (consult local code) or condensate pump. If a condensate neutralization device is required by local code, it must be positioned prior to boiler room drain. Fill the condensate trap with water, check and maintain water level in trap during operation prior to start-up.

GAS SUPPLY PIPING

⚠ WARNING Check the boiler rating plate to make sure that the boiler is for the type of gas that will be used. If it isn't, do not connect the boiler to the gas supply. Failure to comply with this warning can result in extensive property damage, severe personal injury or death!

The FlexCore comes from the factory ready to be piped to the gas supply. If for any reason the boiler is not for the type of gas available at the installation site, call your RBI representative to resolve the problem.

Do not size the gas supply line nominal iron pipe size based only on the boiler gas inlet connection size. The gas supply line (feed) to the boiler gas inlet connection must be designed per an engineered method and utilizing (Table 8) to ensure that the gas supply piping is sized properly. Do not neglect the pressure drop due to pipe fittings. (Table 8) should be used in conjunction with (Table 9) to ensure that the gas supply piping has the capacity to meet the demand. If more than one appliance is supplied by the same supply pipe, the piping must be sized based on the maximum possible demand.

Figure 16 - FlexCore Series Condensate Drain

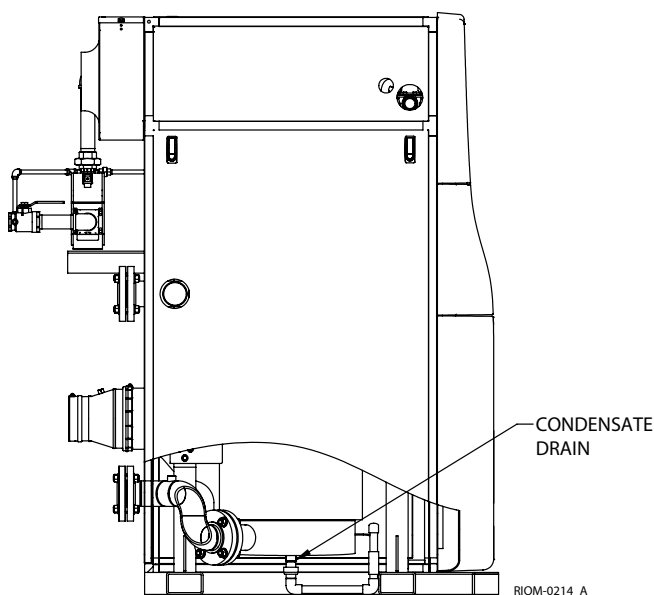

Figure 17 depicts the proper way to connect the boiler to the gas supply piping. The manual shut-off valve **MUST** be installed in the supply piping. It should be installed **5 ft, 1 m** above the floor where required by local codes. Provide a sediment trap at the bottom of the vertical section of the gas supply pipe upstream of the gas controls.

A ground joint union should be installed between the boiler gas controls and the supply piping. Each of these items are needed to ensure long life and ease of servicing. Always use a pipe sealant that is suitable for use with the type of gas (NG/LP) being used.

Table 8 - Gas Pipe Capacity

Maximum pipe capacity in ft ³ /hr based on 0.60 specific gravity gas at a pressure of 0.5 psig or less and a 0.3" WC pressure drop.									
Nominal Iron Pipe Size	Pipe length in feet								
	10	20	30	40	50	60	80	100	150
Maximum gas volume of pipe (ft ³ /hr)									
1"	520	350	285	245	215	195	170	150	120
1 1/4"	1050	730	590	500	440	400	350	305	250
1 1/2"	1600	1100	890	760	670	610	530	460	380
2"	3050	2100	1650	1450	1270	1150	990	870	710
2 1/2"	4800	3300	2700	2300	2000	1850	1600	1400	1130
3"	8500	5900	4700	4100	3600	3250	2800	2500	2000
4"	17,500	12,000	9700	8300	7400	6800	5800	5100	4100
5"	31,700	21,800	17,500	15,000	13,300	12,000	10,300	9110	7320
6"	51,300	35,300	28,300	24,200	21,500	19,500	16,700	14,800	11,900

Note: Multiply the gas volume by 0.62 for propane flow capacity in ft³/hr. Multiply the propane flow capacity by 2500 Btu/ft³ to determine the propane Btu/hr capacity for a given pipe size and length.

Table 9 - Equivalent Pipe Length Chart

Nominal Iron Pipe Size	Type of pipe fitting			
	90° Elbow	Tee ¹	Gas Valve ²	Gas Cock ²
Equivalent pipe length, (ft)				
1"	2.6	5.2	0.6	1.5
1 1/4"	3.5	6.9	0.8	1.9
1 1/2"	4.0	8.0	0.9	2.3
2"	5.2	10.3	1.2	3.0
2 1/2"	6.2	12.3	1.4	3.5
3"	7.7	15.3	1.8	4.5
4"	10.1	20.2	2.4	6.0
5"	12.6	25.2	2.9	7.3
6"	15.2	30.4	3.5	13.4

Notes: 1. For flow through branch.
2. For flow at full open.

NOTICE A lockup style regulator, supplied by others, must be installed, see Figure 17, if gas pressure exceeds (14 in WC). The regulator, when installed as shown, must be installed at a distance of at least 10 pipe diameters from the boiler main gas valve. All boilers are calibrated and factory test fired at (7 in ± 1.0) WC.

NOTICE A true Line Pressure Lock Up Regulator conforming to ANSI Z211.80 must be used. The Lock up pressure shall not exceed the set outlet pressure + (5 in WC). For example: a regulator set at a (7 in WC) run pressure should lock up, at no flow conditions, no greater than (12 in WC).

NOTICE A minimum of (3 in WC) and maximum of (14 in WC) must be maintained to the inlet of the boiler gas train not to exceed a maximum of (1 in WC) drop when firing from minimum input to full load of the gas supply line and all the appliances running.

CAUTION Always use a wrench on the gas valve body when making gas connections to it. Never over-tighten the piping entering the gas valve body or gas valve failure may result!

NOTICE Corrosion of the gas train components with debris and cutting oils can reduce reliable operation which can have a negative effect on the operation & manufacturers warranty of the Dungs gas valve. The factory supplied Dungs MBC modulation gas valve, see Figure 17, incorporates an internal filter that must be inspected and changed at required intervals. Reference the Dungs MBC Installation Instructions - 264541 for detailed instructions. Combined with clean gas pipes and good plumbing practices (such as installing a drip leg), should adequately protect the MBC valve seat, regulator and internal orifices from clogging or damage. However, site conditions might warrant an additional filter. It is recommended that a Dungs FM-FGM In-line Gas Filter or an equivalent should be installed upstream of the appliance gas regulator to the unit.

Safe lighting and other performance criteria were met with the gas manifold and control assembly provided on the boiler. All gas connections MUST be leak tested before putting the boiler into operation.

CAUTION Gas train must be isolated when purging the gas line prior to commissioning the boiler.

NOTICE The factory supplied Dungs MBC modulating gas valve, see figure 17 incorporates an internal filter that must be inspected and changed at required intervals. Reference the Dungs MBC Installation Instructions – 264541 for detailed instructions.

WARNING Never use an open flame to test for gas leaks. Always use an approved leak detection method. Failure to comply with this warning can cause extensive property damage, severe personal injury or death!

Whenever the gas supply piping is pressure tested the boiler gas controls must be protected. If the test pressure is equal to, or less than **1/2 psig, 3.5 kPa** isolate the boiler by closing its' manual shut off valve, see Figure 17. If the test pressure is greater than, or equal to **1/2 psig, 3.5 kPa**, disconnect the boiler and its individual shut-off valve.

ELECTRICAL WIRING

Electrical Power Connections

CAUTION Label all wires prior to disconnection when servicing controls. Wiring errors can cause improper and dangerous operation! Verify proper operation after servicing.

The electrical connections to this boiler must be made in accordance with all applicable local codes and the latest revision of the National Electrical Code, ANSI /NFPA-70. Installation should also conform with CSA C22.1 Canadian Electrical Code Part I if installed in Canada. A separate circuit breaker must be installed per boiler - (if required, the optional local pump FLA must be incorporated and sized accordingly). A properly rated shut-off switch should be located at the boiler. The boiler must be grounded in accordance with the authority having jurisdiction, or if none, the latest revision of the National Electrical Code, ANSI/NFPA-70.

Line voltage field wiring of any controls or other devices must use copper conductors with a minimum size of #14 awg.

Refer to point of connection diagram in back of this manual and the wiring diagram supplied with the boiler for proper wiring connections.

Figure 17 - Gas Supply Piping

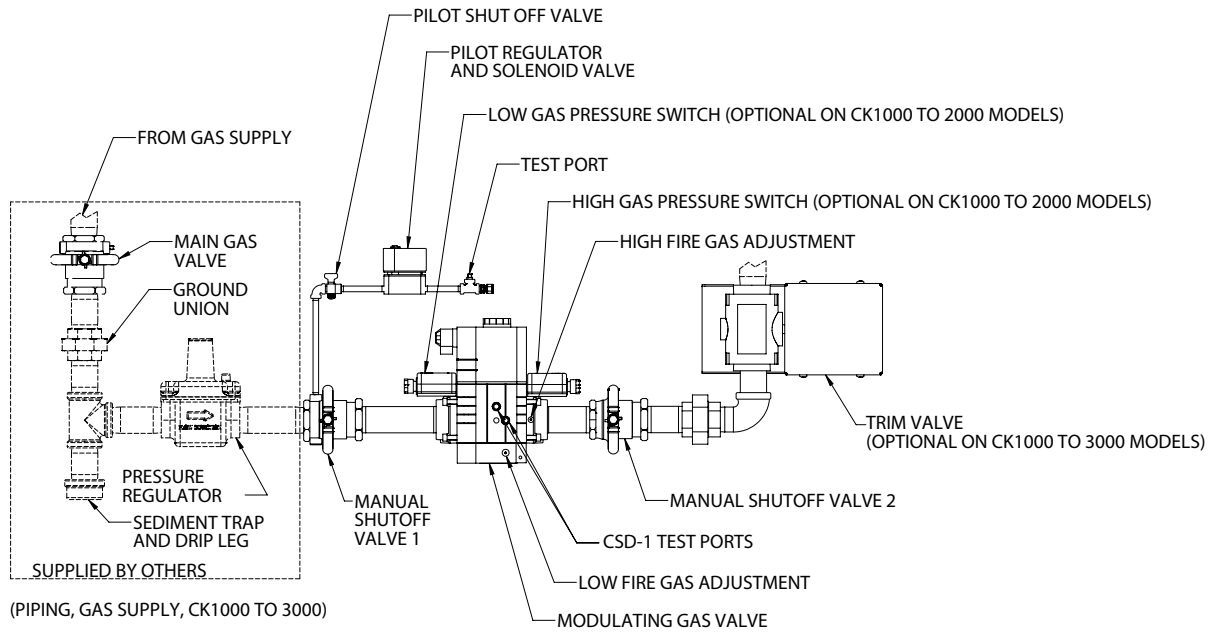

RIOM-0210_D

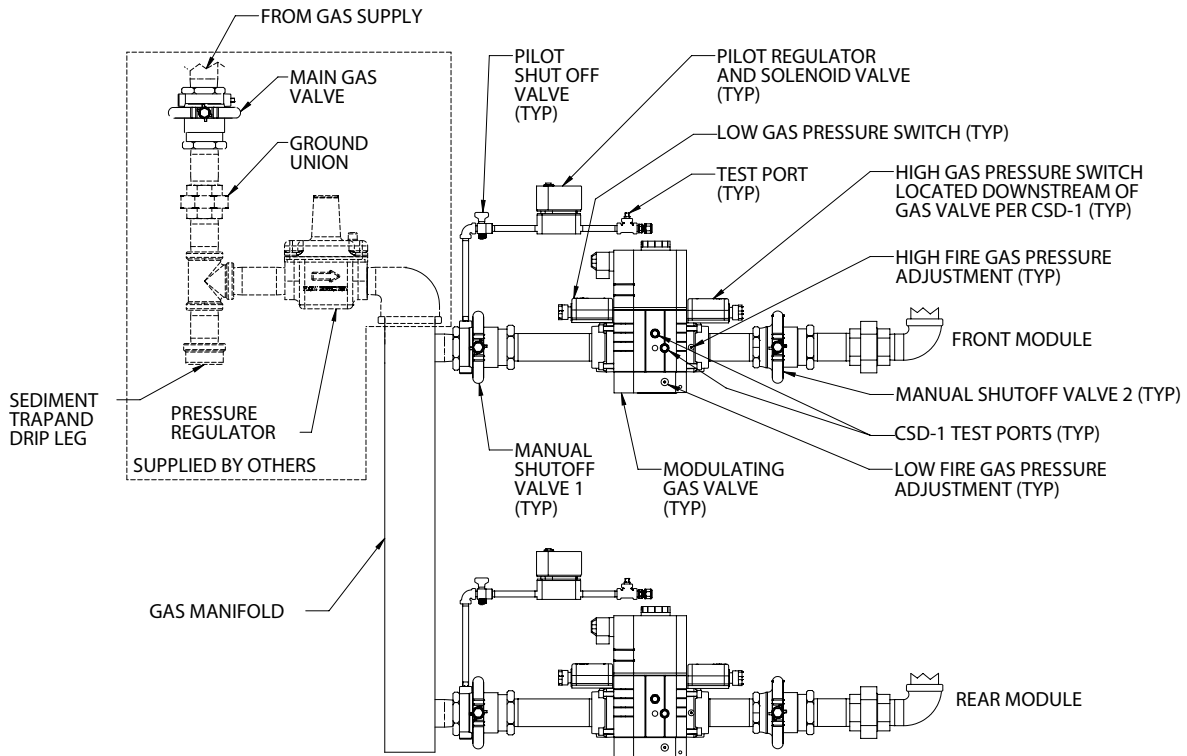

RIOM-0210_C

BOILER OPERATION

⚠ WARNING Before proceeding read and fully understand the instructions contained in this manual. Do not attempt to operate this boiler if it has not been installed in accordance with the guidelines set forth in this manual. Failure to comply with this warning can result in extensive property damage, severe personal injury or death!

Should overheating occur or the gas supply fail to shut off, turn off the manual gas control valve to the appliance.

Do Not interrupt water flow through the boiler.

Hydronic Heating Boilers (Fill System)

Open the make-up water valve and slowly fill the boiler and all of the radiation with water. Ensure that all bleed and drain valves are closed.

Adjust the make-up water pressure regulator so a minimum **5 psig, 82.7 kPa** system pressure is maintained at the highest point in the system piping. A minimum system pressure of **20 psig, 138 kPa** must be maintained at boiler operating conditions. A minimum system pressure of **30 psig, 207 kPa** fill pressure is required, at boiler operating conditions, on glycol mixtures within a closed loop.

Open the system bleed and drain valves, one at a time, to purge the air trapped in the heating system piping.

With the boiler off, run the system pump for at least 30 minutes and bleed the system piping using the bleed valves. If strainers are used in the system piping the make-up water valve should be closed and the strainers checked and cleaned.

The system expansion tank should be checked to ensure that tank air pressure equals cold static fill pressure.

Start the boiler as described in the OPERATING INSTRUCTIONS below. Run the boiler for at least an hour. The system pump(s) and all radiation units must be operated during this time. Ensure that the make-up water valve is open.

Shut the boiler off and open the bleed valves to purge the air trapped in the heating system piping. Close the make-up water valve and check and clean the strainers and make-up water pressure reducing valve.

Open the make-up water valve and adjust the system pressure if necessary.

The system should be checked and bled after three days of operation.

OPERATING INSTRUCTIONS

FOR YOUR SAFETY READ BEFORE OPERATING. ONLY QUALIFIED LICENSED SERVICE TECHNICIANS SHALL START, TROUBLESHOOT, AND SERVICE THIS APPLIANCE WITH APPROVED COMBUSTION ANALYZER.

- A. This appliance is equipped with an ignition device which automatically lights the pilot. Do not try to light the pilot by hand.
- B. BEFORE OPERATING smell all around the appliance area for gas. Be sure to smell next to the floor because some gas is heavier than air and will settle on the floor.

WHAT TO DO IF YOU SMELL GAS

- Do not try to light any appliance.
 - Do not touch any electric switch; do not use any phone in your building.
 - Immediately call your gas supplier from a phone outside of the building. Follow the gas suppliers instructions.
 - If you cannot reach your gas supplier, call the fire department.
- C. Do not use this appliance if any part has been under water. Immediately call a qualified service technician to inspect the appliance and to replace any part of the control system and any gas control that has been under water.

Operating Instructions - (10:1) Startup Procedure - (1000-3000)

1. STOP! Read the safety information above. If, at any time, the appliance will not operate properly, follow the instructions "TO TURN OFF GAS TO APPLIANCE" and call your service technician or gas supplier.
2. Set the operating control to off and disable any outside (BMS) call for heat.
3. Turn off all electric power to the appliance.
4. Remove the front cover.
5. Close manual main shut-off valves 1 and 2 and the pilot gas shut-off valve, Figure 17.
6. Purge the gas piping up to the manual valve ahead of the main gas control of air. When the bleeding is complete, check all gas joints up to the gas valve for leaks.
7. Wait five (5) minutes to clear out any gas.
8. Install a fitting at the supply test port and connect a manometer having a minimum range of 20 in, 508 mm WC to it, Figure 17.
9. Remove the 1/8 in pipe plug from the pilot tee and connect a manometer having a minimum range of 6in, 154mm WC to it.
10. Open the manual main shut-off valves 1 and 2 and the pilot gas shut-off valve, Figure 17.
11. Place the "Remote/Local" switch to Remote.
12. Turn the power switch on the front of the boiler to "on". It will light up when the power is on. If all interlocks are properly closed, the display will say "Standby", Figure 18.
13. Slide the HeatNet controls low fire switch (on the HeatNet control board) to the low fire position.

14. The boiler will begin the start sequence.
15. When the main display reads "PILOT RUNNING" and the flame current is 5VDC, switch the Honeywell 7800 to the "test" position, Figure 18. This will hold the Honeywell 7800 in its ignition state.
16. Adjust the pilot pressure per the CHECKING, ADJUSTMENT & OPERATION section.
17. To adjust the IGNITION value as shown in the display, place the 'S2' Calibration switch located on the 3.0 Heat Net board to the 'CAL' position. A reload message will be displayed then the calibrate screen. Press the 'Adjust' button under the Ignition setting. The value will turn green and the boiler will ramp to the ignition setting. Set the Blower speed, using the arrow keys, to provide the desired rate for ignition. When the adjustment is satisfactory, press the check key to save the setting. When complete place the 'S2' switch back to the 'NORM' position.

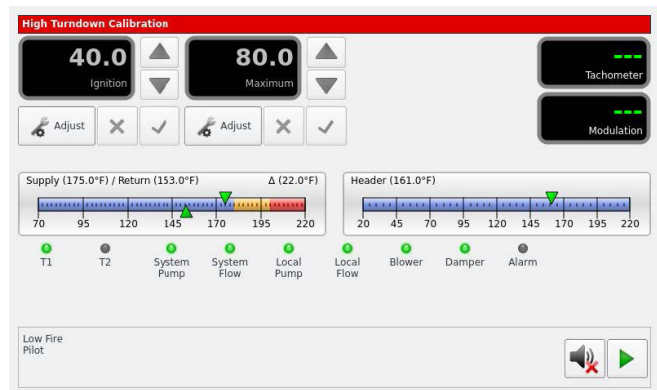

18. Remove the demand from the 7800 control by disabling the low fire switch allowing the boiler to stop.
19. Close manual main shut-off valve 2 and the pilot gas shut-off valve, Figure 17. Remove the manometer fitting from the pilot tee and replace the plug.

Figure 18 - Control Panel

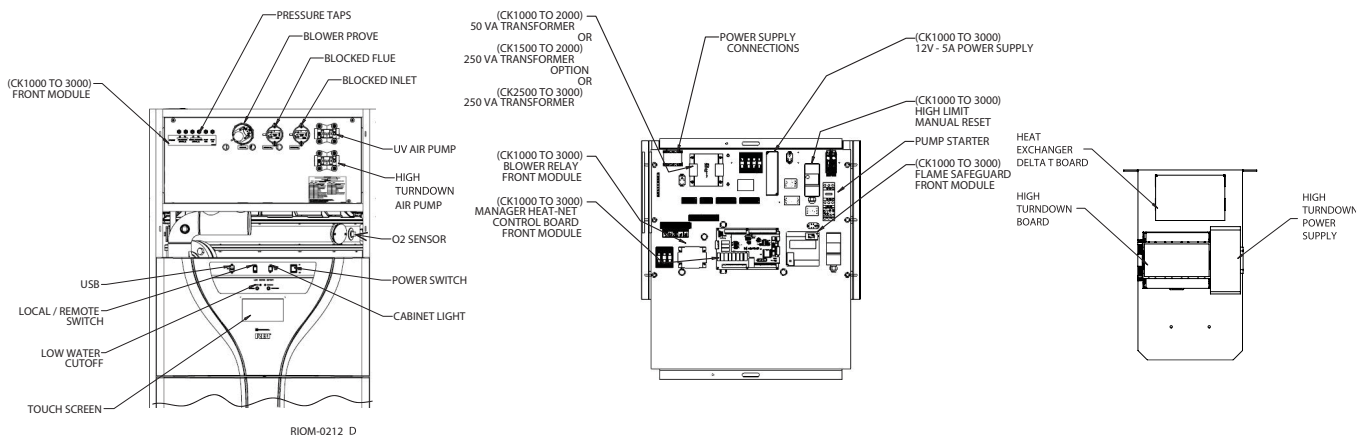

20. Switch the Honeywell 7800 back to "run".
21. Create a minimum input demand as before (enable low fire switch on the HeatNet board). The boiler will begin the start sequence.
22. Monitor the flame current on the 7800. No flame current should be detected and the 7800 should lock out. If flame current is detected at any time up to the 7800 locking out, the 120V wiring on the ignition transformer must be reversed and the test run again to insure that no flame is detected.

⚠ WARNING Warning Improper wiring of the ignition transformer can result in an explosion causing extensive property damage, severe personal injury or death!

23. Open both manual main shut-off valves and the pilot gas shut-off valve.
24. Remove the demand from the 7800 control by disabling the low fire switch allowing the boiler to stop. Reset the Honeywell 7800.
25. Preliminary Air Shutter and Low Fire Combustion settings:
 - a. Enter calibrate screen by placing the calibrate switch 'S2' in the 'CAL' position, then select the "Start Calibrate" button  on the bottom right hand side of the calibrate screen.

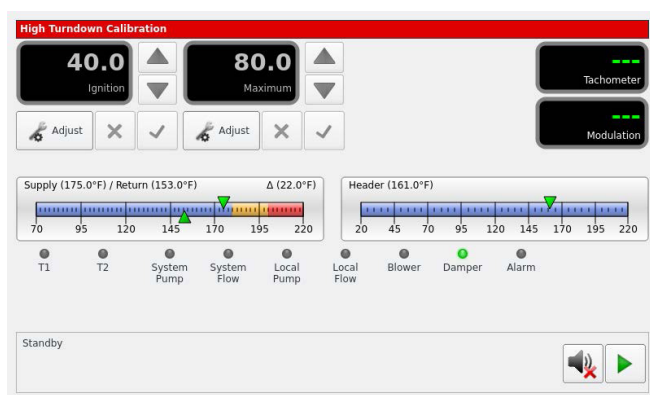

NOTE: The Calibration Settings represent the mapped signal sent to the blower and doesn't reflect the (modulation %) as indicated on the Master/Member Screens.

- b. Write down the Min Air Shutter Setting! This is a factory calculated setting. Press the 'Adjust' button under the Min Air Shutter setting. Using the arrows, bring Min Air Shutter to (20.0).
- c. Give the boiler a call for heat by enabling the low fire switch on the HeatNet control board to the low fire position. Switch the Honeywell 7800 flame safeguard control to the "TEST" position, Figure 18. This will hold the Honeywell 7800 in the purge state.
- d. Take a measurement of the incoming air temperature and make note of the required low fire and high fire set point for both percent O₂ and CO₂. This set point can be found in the IOM, (Table 1). This reading will be needed during low and high fire combustion tests going forward. The air temperature should be measured as close to the filter box as possible.
- e. Switch the Honeywell Flame Safeguard back to "RUN".
- f. Maintain the Min Air Shutter adjustment at 20.0 as the boiler lights and drops to low fire. In calibrate, when the burner is lit, the boiler will maintain 40% input for 20 seconds prior to dropping to low fire. Allow low fire to settle out for a few minutes.
- g. Begin slowly dropping to a Min Air Shutter setting that is 1 point greater than the factory set value, using the following routine. (Example: If the 'Min Air Shutter' factory setting is 9.8, stop decreasing input at 10.8.)
- h. Make a reduction in the Min air Shutter setting. Move in incrementally smaller steps while approaching the desired input to avoid overshoot in zero adjustment. Wait for combustion to stabilize. Confirm the CO₂ is between 7.0%-8.0%. Adjust the low fire CO₂, if necessary, by opening the low fire adjustment door located on the forward side of the main gas valve, (Figure 17). A final low fire combustion adjustment will be done further into the startup procedure.
- i. When finished, select the green check mark. The boiler will operate in a low fire condition.

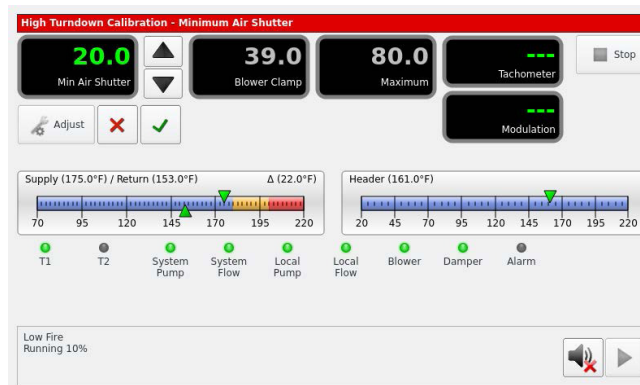

26. Setting the Blower Clamp:

- a. Measure the differential pressure across the Air Shutter, (Figure 18 & 21), and adjust the Blower Clamp so that the drop is $1.30 \pm 0,05$ in WC.
- b. Once the blower is set, select the green check mark.

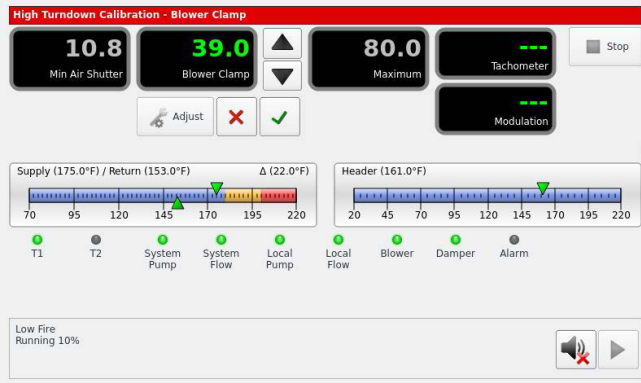

27. Setting the Maximum and High Fire Combustion values:

- a. Verify the 'S2'- Calibration switch located on the 3.0 HeatNet board is in the 'CAL' position. Then select "Adjust" on the Maximum tab. The value will turn green indicating that an adjustment can be changed.
- b. Measure the signal pressure, (Figure 18 & 21).
- c. Adjust the Maximum value, if necessary, using the arrow keys so that the signal pressure (delta-p) matches what is listed in the IOM, (Table 12a). Wait for combustion to stabilize.

28. Check/adjust combustion. Make adjustments to the Dungs high fire trim shutter, if necessary, to maintain proper combustion per the required setpoint taken from (Step 25d). The high fire trim adjustment is located on the outlet flange, (Figure 17), of the gas valve.

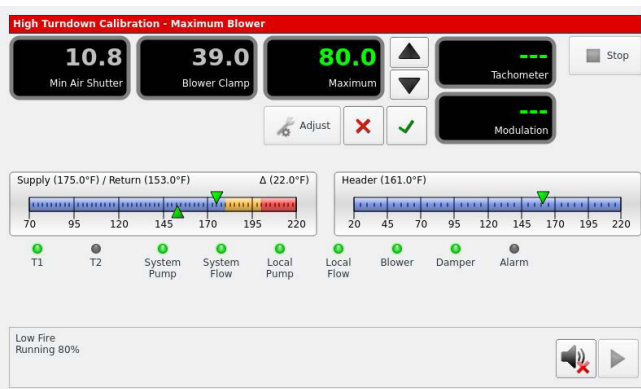

29. When the adjustment is satisfactory press the green check mark to save the setting. The boiler will return to low fire.

30. Setting the Min Air Shutter and Low Fire values:

- a. Verify the 'S2'- Calibration switch located on the 3.0 HeatNet board is in the 'CAL' position. Then select "Adjust" on the Min Air Shutter tab. The value will turn green indicating that an adjustment can be changed.
- b. Wait for combustion to stabilize.
- c. Measure the signal pressure, (Figure 18 & 21)
- d. Adjust the Min Air Shutter value by 0.1 intervals, using the arrow keys, to achieve the required pressure delta p - (Table 12a), see pressure taps - (Figure 18 & 21).
- e. Measure flue gas CO₂ concentration. To achieve the required combustion - CO₂/O₂ - (Table 11) adjust the low fire O₂-CO₂ to the required set point recorded in (Step 25d). Access to this adjustment screw is accomplished by opening the low fire adjustment door located on the forward facing side of the main gas valve, (Figure 17).
- f. Repeat the above steps if necessary.

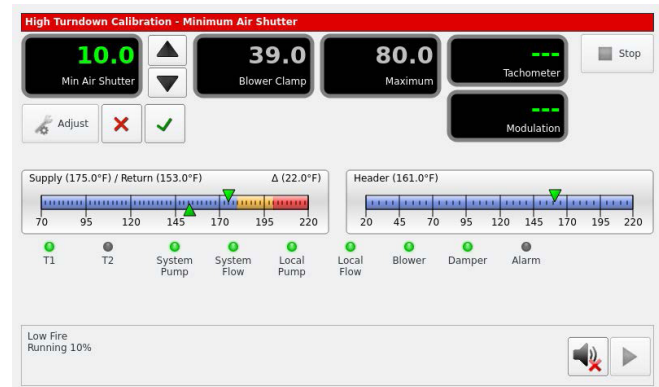

- g. When the adjustment is satisfactory press the check key to save the setting. When complete, place the 'S2' switch back to the 'NORM' position.
- h. Disable the low fire hold switch to allow the boiler to go into standby.
- i. Follow the instructions in the HeatNet Control manual to allow adjustments required for high altitude installations.

Operating Instructions - (5:1) Startup Procedure - (3500-6000)

1. STOP! Read the safety information above. If, at any time, the appliance will not operate properly, follow the instructions "TO TURN OFF GAS TO APPLIANCE" and call your service technician or gas supplier.
2. Set the operating control to off and disable any outside (BMS) call for heat.
3. Turn off all electric power to the appliance.
4. Remove the front cover.
5. Close manual main shut-off valves 1 and 2 and the pilot gas shut-off valve, Figure 17. Follow the same procedure for multiple gas train configurations (CK3500 - CK6000).
6. Purge the gas piping up to the manual valve ahead of the main gas control of air. When the bleeding is complete, check all gas joints up to the gas valve for leaks.
7. Wait five (5) minutes to clear out any gas.
8. Install a fitting at the supply test port and connect a manometer having a minimum range of **20 in, 508 mm WC** to it, Figure 17.
9. See the "Gas Supply Piping" section for the required static and run gas pressure.
10. Open the manual main shut-off valves 1 and 2 and the pilot gas shut-off valve, Figure 17. Follow the same procedure for multiple gas train configurations (CK3500 - CK6000).
11. Place the "Remote/Local" switch to Remote.
12. Turn the power switch on the front of the boiler to "on". It will light up when the power is on. If all interlocks are properly closed, the display will say "Standby", Figure 18a.
13. Slide the HeatNet controls low fire switch (on the HeatNet control board) to the low fire position.
14. The boiler will begin the start sequence.
15. When the main display reads "PILOT RUNNING" and the flame current is 5VDC, switch the Honeywell 7800 test/run switch into the "test" position, Figure 18. This will hold the Honeywell 7800 in its ignition state. For boiler sizes (CK3500 - CK6000) place the test/run switch on both flame safeguards into the "test" position. Both modules must be in the "test" position otherwise the unit will shutdown.

16. Adjust the pilot pressure per the CHECKING, ADJUSTMENT & OPERATION section.
17. To adjust the IGNITION value as shown in the display, place the 'S2' Calibration switch located on the 3.0 HeatNet board to the 'CAL' position. A reload message will be displayed then the calibrate screen. Press the 'Adjust' button under the Ignition (%) setting. The percentage value will turn green and the boiler will ramp to the ignition setting. Set the Blower speed, using the arrow keys, to provide the desired rate for ignition. When the adjustment is satisfactory, press the check key to save the setting. When complete place the 'S2' switch back to the 'NORM' position.

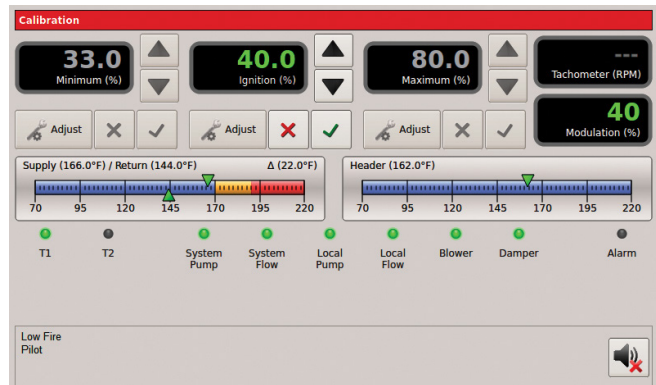

NOTICE For boiler sizes (CK3500-CK6000) press the "Exchanger" graphical symbol to access the Calibration screen, (Ignition %, Minimum VFD%, Maximum VFD%), of each individual heat exchanger module. The following screen illustrates the menu selector.

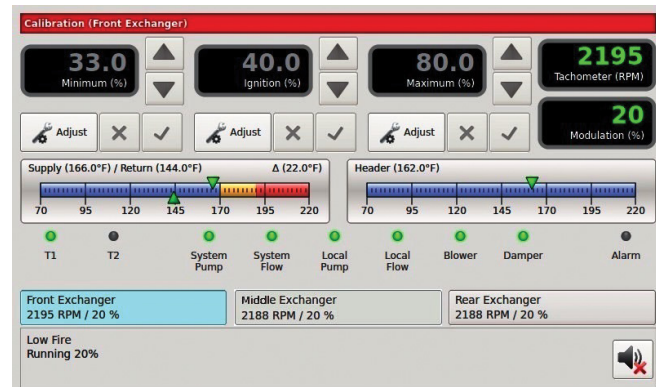

NOTICE The Calibration (Min % & Max %) represents the mapped signal sent to the blower and doesn't reflect the (modulation %) as indicated on the Master/Member Screens.

Figure 18a - Control Panel Components

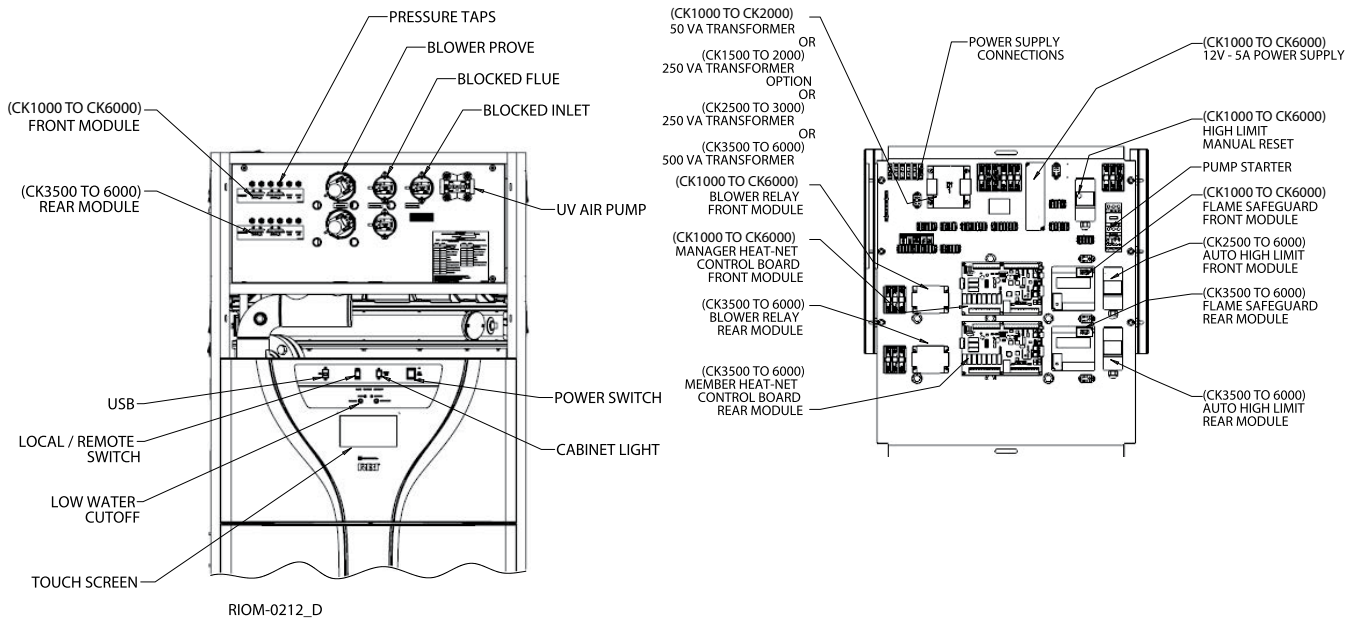

18. Remove the demand from the 7800 control by disabling the low fire switch allowing the boiler to stop.
19. Close manual main shut-off valve 2 and the pilot gas shut-off valve, Figure 17. Connect both sides of a manometer or pressure gauge to the manometer pressure taps (differential pressure barbed connections) on the pressure test manifold located inside the upper control panel. Add additional manometers to the set of pressure taps provided for the middle and rear modules on units (CK3500 -CK6000). (See Figure 18a & Figure 21).
20. Switch the Honeywell 7800 back to "run".
21. Create a minimum input demand as before (enable the low fire switch on the HeatNet board). The boiler will begin the start sequence. For units (CK3500 - CK6000), the low fire switch on the Manager HeatNet Board will enable all the additional modules.
22. Monitor the flame current on the 7800. No flame current should be detected and the 7800 should lock out. If flame current is detected at any time up to the 7800 locking out, the 120V wiring on the ignition transformer must be reversed and the test run again to insure that no flame is detected.

⚠ WARNING Improper wiring of the ignition transformer can result in an explosion causing extensive property damage, severe personal injury or death!

23. Open both manual main shut-off valves and the pilot gas shut-off valve.
24. Reset the Honeywell 7800. The boiler will start and will run at minimum input rate.
25. Setting the Min VFD and Low Fire Combustion values: The boiler will cycle and achieve low fire status. Allow low fire to settle out for a few minutes and observe the combustion reading.

NOTICE The Calibration (Min % & Max %) represents the mapped signal sent to the blower and doesn't reflect the (modulation %) as indicated on the Master/Member Screens.

- a. Place the 'S2' - Calibration switch located on the 3.0 HeatNet board to the 'CAL' position. A reloading message will be displayed and then the calibrate screen. Follow the same procedure for the middle and rear modules on units (CK3500 - CK6000).

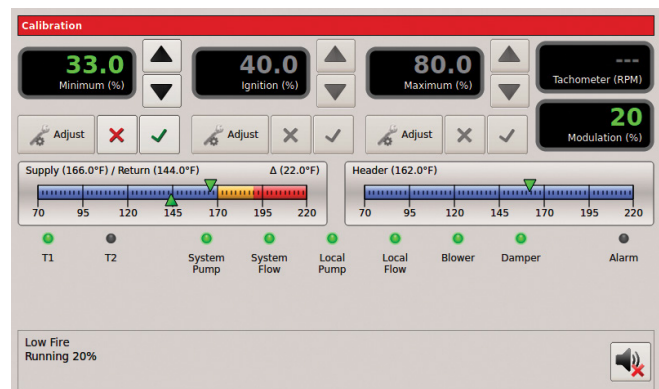

- b. Press the 'Adjust' button under the Minimum (%) setting. The percentage value will turn green. Adjust the minimum value (%), using the arrow keys, to achieve the required combustion - CO₂/O₂, (Table 11), and pressure – delta p, (Table 12), at low fire based on the desired turn down.
- c. Adjust low fire O₂-CO₂ by opening the low fire adjustment door located on the forward facing side of the main gas valve, (Figure 17). Inserting an allen wrench and rotating the allen screw clock-wise will increase the CO₂ and lower the O₂; rotating counter clock-wise will decrease the CO₂ and increase the O₂.
- d. When the adjustment is satisfactory, press the check key to save the setting.

26. Setting the Max VFD and High Fire Combustion values: Remove the demand from the 7800 control by disabling the low fire switch allowing the boiler to stop.

- a. Verify the 'S2'- Calibration switch located on the 3.0 HeatNet board is in the 'CAL' position. While in Standby (no call for heat on inputs), the Max VFD percentage may be preset, before firing the boiler. Press the 'Adjust' button under the Maximum (%) setting and set this value to a lower input value (50%). This will allow for manual input control during the high fire set up process (26b.). When the adjustment is satisfactory press the check key to save the setting. Follow the same procedure for the middle and rear module on units (CK3500 - CK6000).

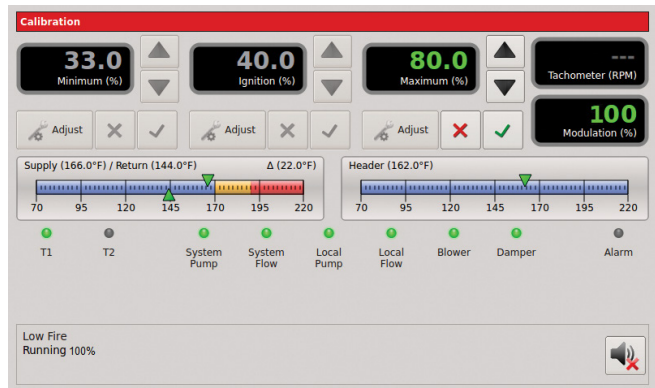

- b. Using the low fire switch on the HeatNet board create a minimum input demand. The boiler will cycle to low fire position. Press the 'Adjust' button under the Maximum (%) setting. Boiler input will modulate to the previously set (50%) input. The percentage value will turn green indicating that it can be changed. Adjust the maximum value (%), using the arrow keys, to achieve the required combustion – CO₂/O₂ (Table 11), and pressure – delta p, (Table 12).
- c. The high fire trim adjustment is located on the outlet flange, (Figure 17), of the gas valve.
- d. When the adjustment is satisfactory press the check key to save the setting. Follow the same procedure for the middle and rear modules on units (CK3500-CK6000). When complete, place the 'S2' switch back to the 'NORM' position.
- e. Allow the boiler to settle into min input and observe combustion and pressure-delta p readings to ensure the boiler is operating correctly. Make any required adjustments. When complete disable the low fire hold switch.
- f. Follow the instructions in the HeatNet Control manual to allow adjustments required for high altitude installations.

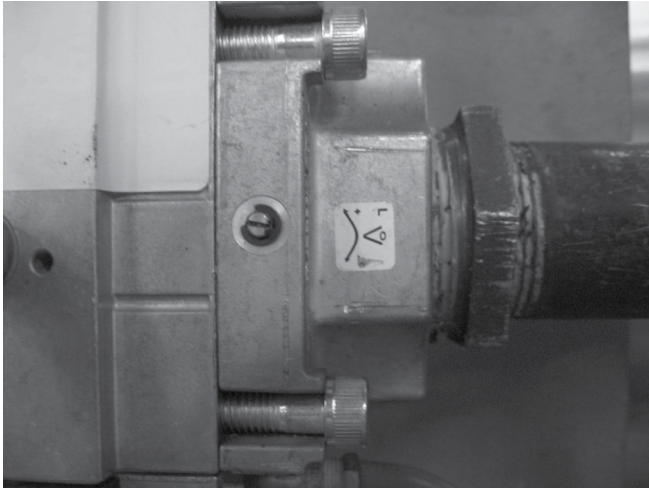

High Fire CO₂ Adjustment Screw - Clockwise = Increase
Counterclockwise = Decrease

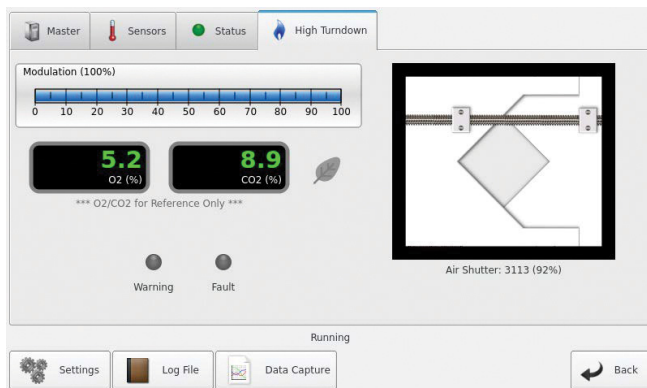

The HeatNet High Turndown menu screen provides the following informational data:

- The Modulation graph indicates the boiler input percentage.
- The Air Shutter percentage indicates the shutter blade position at various operational cycle locations.
- The O₂/CO₂ flue gas combustion values are for Reference Only - see O₂ Sensor location (Figure 18). The O₂ Sensor calibration period may take up to 6 hrs of steady state operation - variations in readings may be observed. A calibrated flue gas analyzer must be used for final adjustment. Failure to verify combustion could result with improper conditions that could lead to personal injury, death, or property damage.
- The Warning/Fault indicators are relevant for factory trouble shooting. LED's will illuminate when a high turndown fault occurs. See the HeatNet Supplement High Turndown Control Manual for an explanation of each fault.

TO TURN OFF GAS TO APPLIANCE

1. Set the operating control to its lowest setting.
2. Turn off all electric power to the boiler if service is to be performed.
3. Close the manual main and pilot gas shut-off valves.

SEQUENCE OF OPERATION

NO DEMAND

Standby

1. The boiler is idle with no interlocks in the fault condition.

DEMAND

Pre-Purge

1. The blower operates at purge RPM. The water flow interlock must 'make' within 15 seconds after the demand signal is initiated.
2. The Honeywell 7800 starts a 10 second purge delay once the air prove switch contacts close.

Pilot Run - %Input

1. The blower operates at minimum ignition setting. See the calibration section in the "FlexCore Series Control IOM" to enter the calibration menus.
2. The ignition transformer is energized. The pilot solenoid valve opens for the 10 second pilot ignition trial.

Main Run %Input

1. The main gas valve opens.
2. The ignition transformer is de-energized.
3. The pilot solenoid valve closes.
4. The blower stays at the minimum input setting for 3 seconds then operates at demand % input. See the calibration section in the "FlexCore Series Control-IOM" to enter the calibration menus.

NO DEMAND

Post-Purge

1. The main gas valve closes.
2. The blower operates at purge RPM for 10 seconds.
3. The boiler is idle with no interlocks in the fault condition.

FlexCore Stainless Steel Condensing Boilers – Installation Manual

Table 11 - Combustion Settings

FlexCore-Series Whirlwind Bekaert Burner w/Gas Orifice Slide Trim**						
Inlet Air Temp.	NG					
	CO ₂ %			O ₂ %		
	Low Fire		High Fire	Low Fire		High Fire
	10%	20%		10%	20%	
-40°F	6.5	7.2	8.0	9.4	8.3	6.9
-30°F	6.6	7.3	8.1	9.2	8.1	6.7
-20°F	6.7	7.4	8.2	9.0	7.9	6.5
-10°F	6.8	7.5	8.3	8.9	7.8	6.4
0°F	6.9	7.6	8.4	8.7	7.6	6.2
10°F	7.0	7.7	8.5	8.5	7.4	6.1
20°F	7.1	7.8	8.6	8.3	7.2	5.9
30°F	7.2	7.9	8.7	8.2	7.1	5.7
40°F	7.3	8.0	8.8	8.1	6.9	5.5
50°F	7.4	8.1	8.9	7.9	6.7	5.3
60°F	7.5	8.2	9.0	7.8	6.5	5.2
70°F	7.6	8.3	9.1	7.6	6.4	5.0
80°F	7.7	8.4	9.2	7.4	6.2	4.8
90°F	7.8	8.5	9.3	7.2	6.1	4.7
100°F	7.9	8.6	9.4	7.1	5.9	4.5

**Located on outlet flange of gas valve. (Figure 17)

Due to job conditions, deviation from specified may be required – allow ± (0.2)% range adjustment.

Note: When units are installed with direct sealed combustion air, during periods of time with low outdoor temperature, it is possible for the room air to condense and possibly form frost on the air handling components of the boiler. Refer to: (2015 ASHRAE Cold-Climate Buildings Design Guide).

Table 12 - Pressure Signal (P) - (Nat. Gas)

Firing Rate	1000	1500	2000	2500	3000
	(Delta P - W.C.)	(Delta P - W.C.)	(Delta P - W.C.)	(Delta P - W.C.)	(Delta P - W.C.)
100%	8.30	11.4	9.30	12.4	9.00
33%	0.84	1.20	1.15	1.50	1.00
25%	0.45	0.90	0.75	1.00	0.55
20%	0.36	0.60	0.44	0.58	0.35
15%	0.26	0.40	0.30	0.40	0.25
10%	0.10	0.20	0.20	0.20	0.10

Firing Rate	3500 (Delta P - W.C.)		4000 (Delta P - W.C.)		4500 (Delta P - W.C.)		5000 (Delta P - W.C.)		6000 (Delta P - W.C.)	
	Front Module	Rear Module	Front Module	Rear Module	Front Module	Rear Module	Front Module	Rear Module	Front Module	Rear Module
100%	9.50	9.00	9.00	9.50	9.50	9.00	9.00	9.50	7.00	7.50
33%	1.20	1.15	1.15	1.20	1.20	1.15	1.15	1.20	0.85	0.90
25%	0.80	0.75	0.75	0.80	0.80	0.75	0.75	0.80	0.60	0.65
20%	0.45	0.45	0.45	0.45	0.45	0.45	0.45	0.45	0.40	0.40

To determine signal in mm WC, multiply signal pressure by 25.4.

FireTube Series "HeatNet Control" Troubleshooting (Firing the FireTube Boiler)

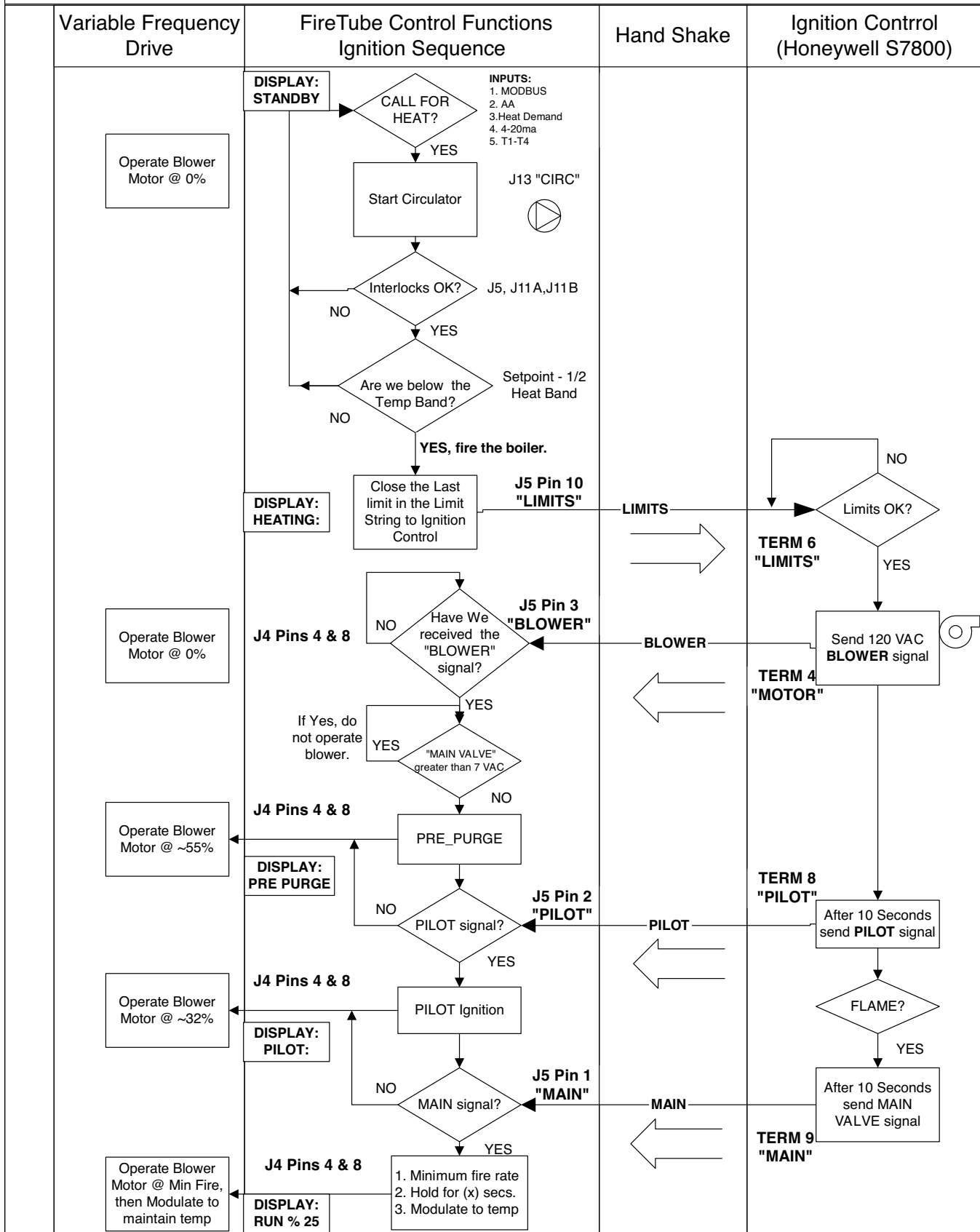

CHECKING, ADJUSTMENT & OPERATION

Spark Gap

The gap has to be measured and adjusted with the igniter removed from the boiler. Observe the trial for ignition to confirm that the spark is strong and continuous. If not, allow the electrodes to cool. Check and adjust the spark gap as shown in Figure 19. Electrode tips should face slightly downward.

Figure 19 - Spark Gap

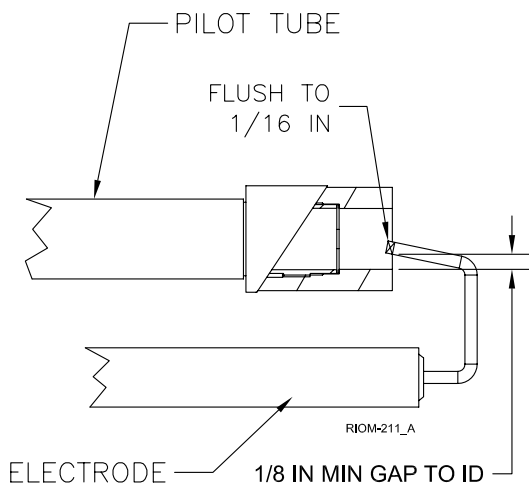

Pilot Adjustment

Connect one side of a manometer or pressure gauge having a minimum range of 6 in., 15 mm WC to the manometer pressure tap (pilot gas barbed connection) on the pressure test manifold located inside the upper control panel. (See Figure 21). For units (CK3500 - CK6000), add additional manometers to the (pilot gas barbed connection) provided for the middle and rear modules. Leave the other side of the manometer open to atmosphere. Open the pilot gas shut-off valve. With the unit powered generate a call for heat. When the prepurge is complete the ignition/pilot trial will begin. At this point put the Honeywell 7895C test switch in the test position. For units (CK3500 - CK6000), place the test/run switch on both flame safeguards into test mode. The control will hold in the ignition/pilot sequence allowing you to check the pressure. Verify that the pilot gas pressure is within a range of (2.5 in.-3.5 in. WC). Check the pilot air pressure using the service valve marked "Pilot Air Valve". The pilot air pressure should be .60 in. WC (± 0.1 in.).

To adjust the pilot the following steps must be taken:

1. Remove the pilot gas pressure regulator cap.
2. Turn the pressure regulator adjustment screw clockwise to increase the pressure and counterclockwise to decrease it.
3. Replace the pressure regulator adjustment screw cap.

CAUTION Never force the regulator adjustment screw beyond the stop limits or damage to the regulator will occur!

Pilot flame UV signal

Before you check the pilot signal you need to make sure the polarity of the 120v supply to the ignition transformer is correct. To do this close the manual main shut-off valve 2 (Figure 17) and the manual pilot shut-off valve. With the unit powered generate a call for heat. The boiler will start to go through its start up sequence. During the ignition/pilot sequence observe the lights on the Honeywell 7895C. The pilot light should come on but not the flame light. If the flame light comes on along with the pilot light, interrupt the call for heat and turn off the main power. Reverse the 120v supply leads to the Honeywell 652B ignition transformer and run this test again. With this done the flame signal should be between 3vdc and 5vdc. Check the voltage on the test connections of the Honeywell 7895C's amplifier with a dc voltmeter.

Figure 20 - Pilot Assembly

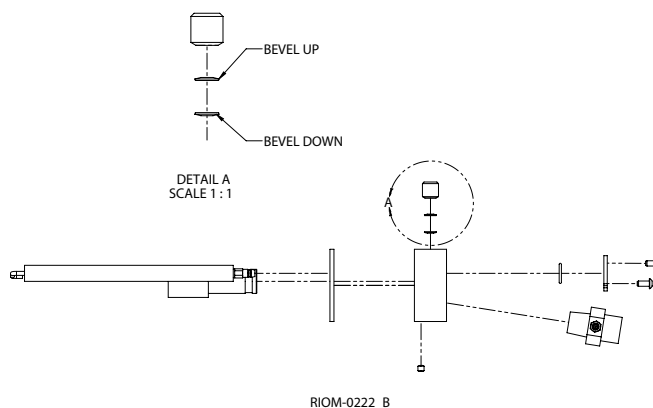

Ignition Safety

To test the ignition safety shutoff device, close the manual shutoff valve 1 (Figure 17) in the gas supply line. Within 5 seconds of main burner flame extinction, the main gas valve solenoid should close. The control board will lockout and display “LOW GAS PRESSURE”. Open the manual shutoff valve in the gas supply line and reset the control board by toggling the power switch.

To confirm the input of the unit follow the instructions in the INPUT RATE section below.

Input Rate, Natural Gas

1. Turn off all other gas appliances that use the same gas meter as the boiler.
2. Call your gas supplier and ask for the heating value of the gas (Btu per cu/ft).
3. Start the boiler and let it run for 15 minutes.
4. With the boiler operation clock the time that it takes to burn 10 cu/ft of gas at full fire.
5. Insert the heating value and the time, in seconds, into the formula below.
6. $\text{Input} = 10 / \text{seconds (Btu per cu/ft)}(3600)$.
7. If the computed rate exceeds the desired input follow section “operating instructions” to make the appropriate adjustments.

CAUTION Never increase the input to the boiler above that for which it is rated. Doing so can cause premature failure of the boiler!

Low Water Cutoff

Ensure that the low water cutoff device(s) function properly.

Test in accordance with the manufacturer’s instructions included with the device(s).

DIAGNOSTICS

The FlexCore has a display that indicates the sequence of operation, Figure 18, 18a & 18b. The display will also list faults should the unit fail to operate. An explanation of each fault is listed below.

STANDBY: Indicates that power is being supplied to the unit and there is no call for heat.

STANDBY OPERATING LIMIT: Indicates that the operating limit if used is open.

HONEYWELL ALARM “flashing”: Indicates that there is a call for heat and the Honeywell 7895C is locked out.

STANDBY START DEMAND: Indicates that there is a call for heat and the Honeywell 7895C is not functioning or is locked out.

STANDBY WATER LIMIT: Indicates that either the high limit, low water cut off, or both are open without a call for heat.

LOCKOUT WATER LIMIT: Indicates that either the high limit, low water cut off, or both are open with a call for heat.

STANDBY GAS PRESSURE: Indicates that the low gas pressure switch or the high gas pressure switch if used is open without a call for heat.

LOCKOUT GAS PRESSURE: Indicates that the low gas pressure switch or the high gas pressure switch if used is open with a call for heat.

WAITING FOR FLOW: Indicates that minimum flow hasn't been achieved.

FAULT INSUFFICIENT FLOW: Indicates that inadequate flow is present.

LWCO LOCKOUT: Indicates low or no water in the boiler.

MAINTENANCE

⚠ WARNING Disconnect electrical power and close the manual gas shut off valve before performing maintenance or severe personal injury may result!

⚠ CAUTION Servicing, inspection and adjustment must be done by a trained technician in accordance with all applicable local and national codes. Improper servicing or adjustment can damage the boiler!

The boiler must be inspected at least once a year and before each heating season. Make sure that combustion readings and air box pressures are taken on each boiler and match the desired emissions outlined under the specification in the Installation Manual – adjust as necessary. Accessing the burner compartment isn't necessary during normal maintenance unless combustion values or air box pressures don't meet specification.

⚠ CAUTION Improper burner servicing can result in premature burner failure voiding the warranty!

Burner Removal & Inspection

⚠ WARNING Wear a tightly fitted dust mask when servicing the burner and gently handle the burner and its gasket to prevent inhalation of airborne fibers.

NOTICE Do not attempt to remove the burner without having a burner gasket kit on hand.

Heat Exchanger Cleaning

In the unlikely event that the heat exchanger becomes blocked consult the factory for the proper cleaning procedure.

Air Intake & Vent System

Thoroughly inspect the air intake and vent system for any signs of blockage, corrosion, or leakage and periodically clean screen in the vent terminal (where applicable). Immediately replace any unsound vent system piping. Inspect the air filter and replace when required.

Controls

Use the BOILER OPERATION and CHECKING AND ADJUSTMENT sections of this manual for reference.

1. Check the operating controls for proper operation.
2. The probe on a probe low water cut off must be removed, cleaned and inspected at least once a year. Ensure that the low water cutoffs operate properly. If not, replace them.
3. The flow sensor isolation valves must be open in order for proper operation.

NOTICE In the unlikely event that the SIKA flow sensor requires cleaning, in order to flush the flow sensor, close the ball valve installed upstream of the flow sensor, connect a hose to the drain fitting provided and open the drain valve. Drain approximately a gallon of water to properly flush the flow sensor. The drain is then closed and the upstream valve reopened.

4. The relief valve should not weep or discharge water at normal system pressure - this may be due to thermal expansion in a closed water supply system. If it does contact a qualified service technician to have it inspected. **NEVER** try to clean or repair the relief valve! If the valve fails to operate properly, have it replaced!
5. The aquastat high limit controls the maximum water temperature in the boiler. It is adjustable from **100°F, 38°C** to **210°F, 99°C**. If the water temperature reaches the set temperature before the demand for heat has been met, the aquastat high limit should shut the boiler off. The water temperature should never exceed the maximum set point of **210°F, 99°C**. The aquastat high limit cannot be repaired. If it fails to function properly replace it.
6. Visually check the pilot and main burner flames to ensure proper operation, see Figure 20.

⚠ WARNING Visual flame appearance with proper combustion will have a red and blue striped appearance at low fire and flecked areas of red with a majority of blue across the metal mesh burner at high fire. Areas of deep red indicate an infrared condition requiring a combustion adjustment to reduce CO₂ levels.

Figure 20 - Main Burner Flame



Figure 21 - Pressure Switches (10:1) - (1000-3000)

RIOM-0218_D

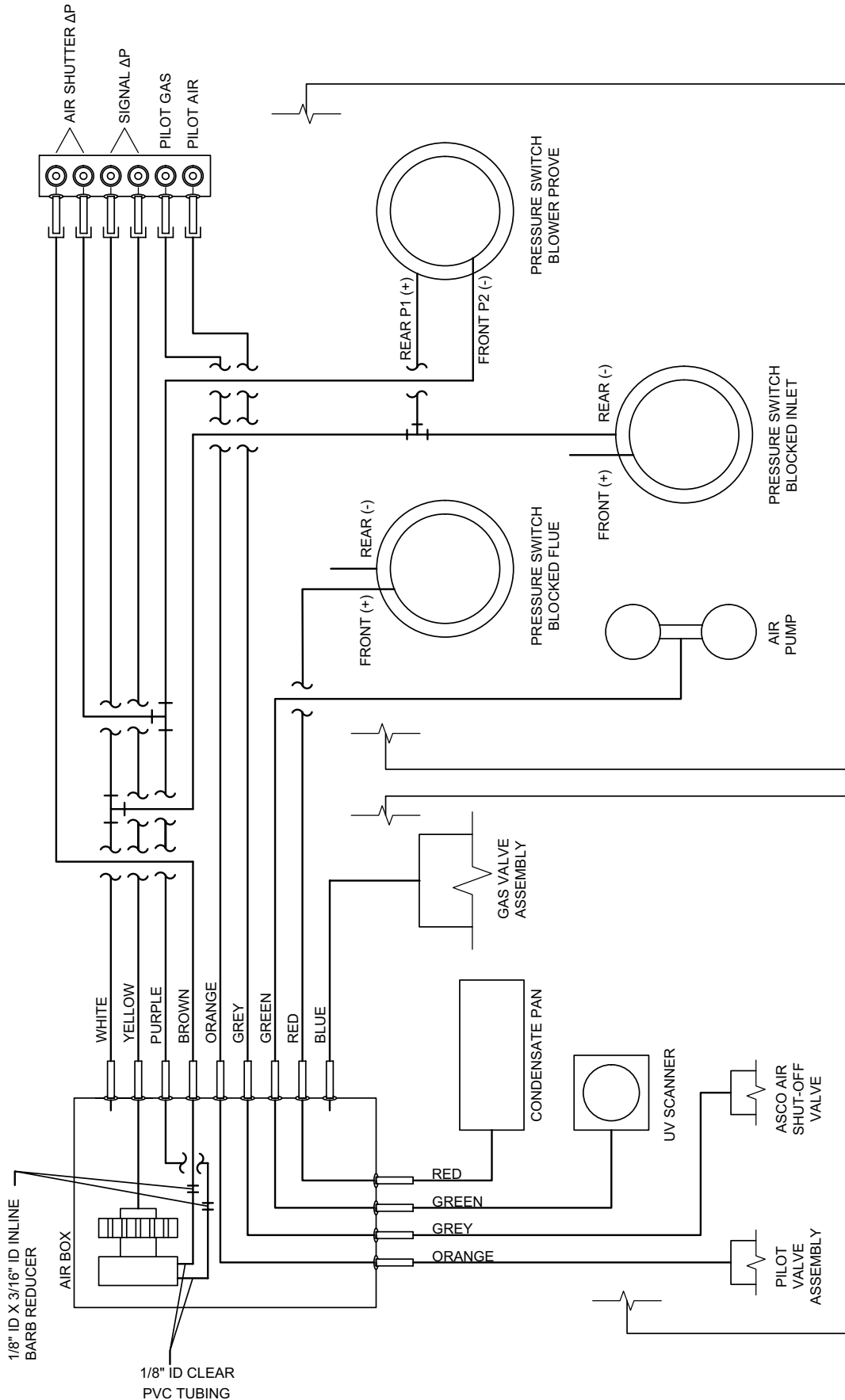

- NOTES:
1. TYPICAL PER EACH INDIVIDUAL MODULE
 2. EACH MODULE HAS A UNIQUE BLOWER PROVE AND BLOCKED FLUE SWITCH. ONE COMMON BLOCKED INLET SWITCH IS USED FOR ALL MODULES.

SWITCH SETTINGS IN "W.C.	
SWITCH	SETTINGS
BLOWER PROVE	0.4
BLOCKED FLUE	2.5
BLOCKED INLET	3.0

LEGEND	
	FLEXIBLE PLASTIC TUBING
(+)	POSITIVE PRESSURE TAP
(-)	NEGATIVE PRESSURE TAP

Figure 21 - Continued Pressure Switches (5:1) - (3500-6000)

RIOM-0218_D

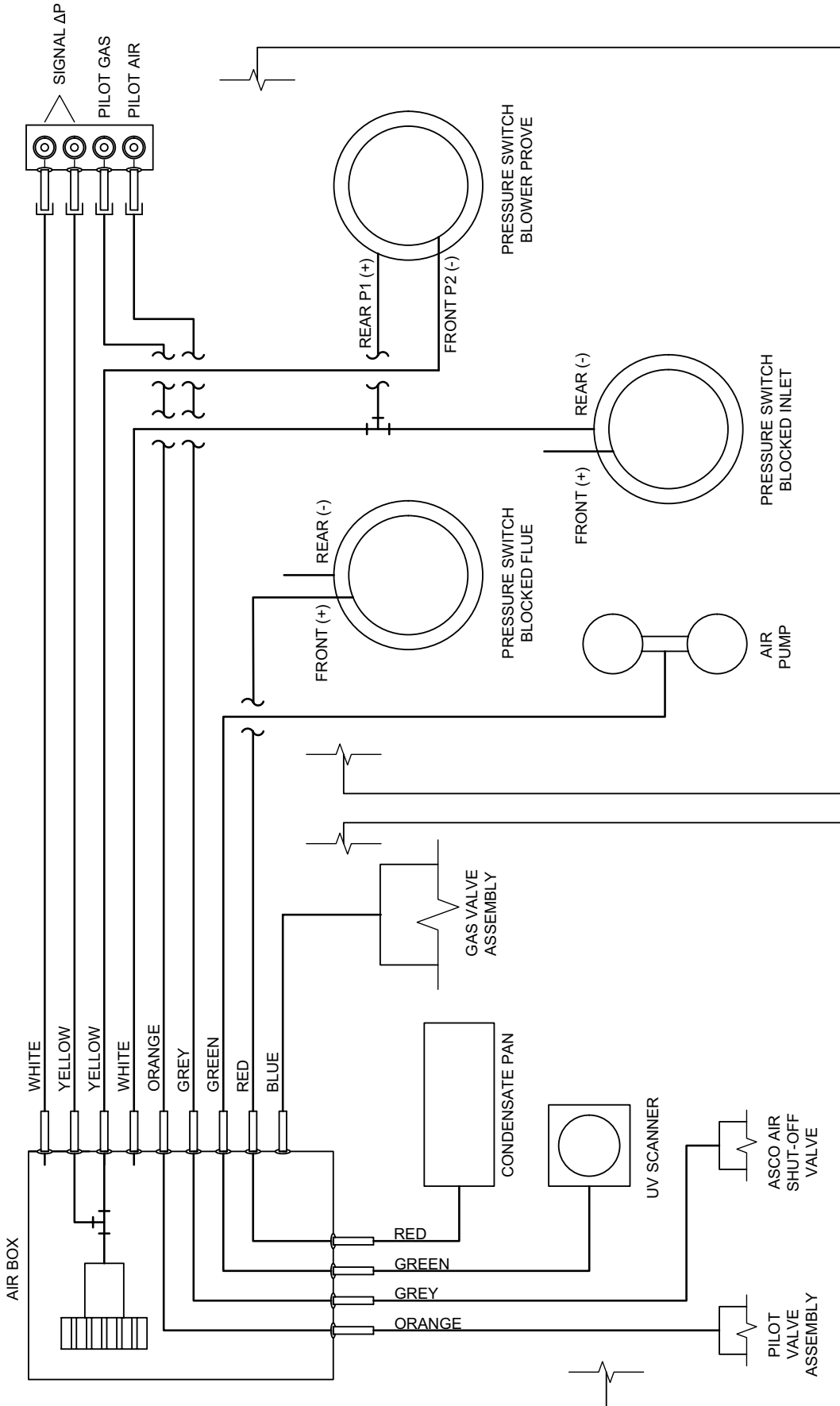

- NOTES:
1. TYPICAL PER EACH INDIVIDUAL MODULE.
 2. EACH MODULE HAS A UNIQUE BLOWER PROVE AND BLOCKED FLUE SWITCH. ONE COMMON BLOCKED INLET SWITCH IS USED FOR ALL MODULES.

SWITCH SETTINGS IN "W.C.	
SWITCH	SETTINGS
BLOWER PROVE	0.2
BLOCKED FLUE	2.5
BLOCKED INLET	3.0

LEGEND	
—	FLEXIBLE PLASTIC TUBING
(+)	POSITIVE PRESSURE TAP
(-)	NEGATIVE PRESSURE TAP

Figure 23 - Relays, Interlocks and Boiler Status

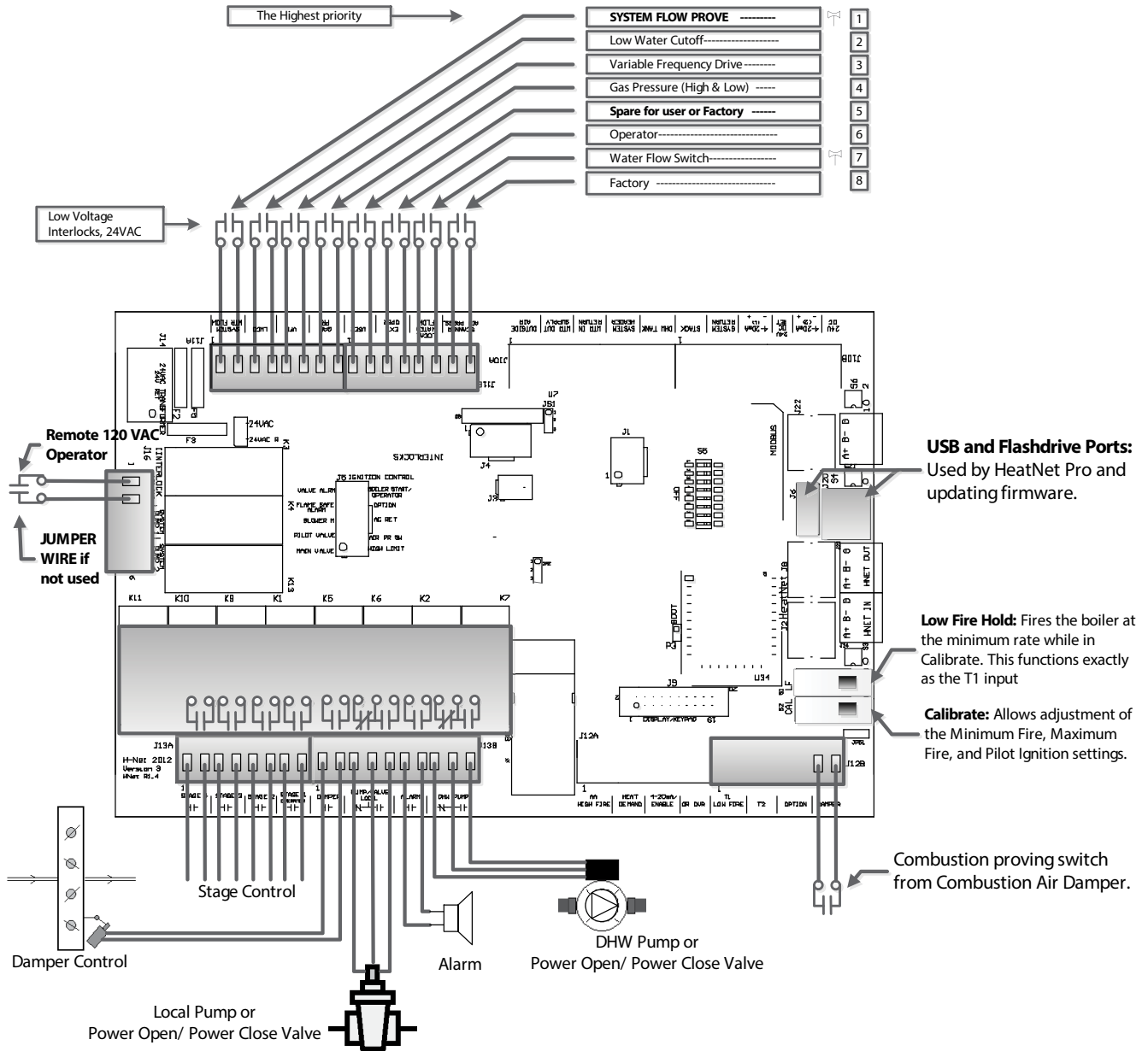

Figure 24 - Single Unit Replacement Parts

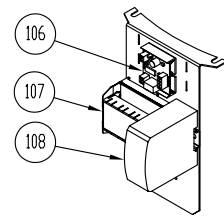
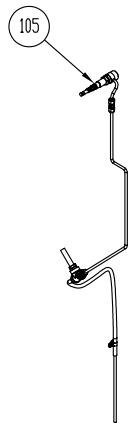
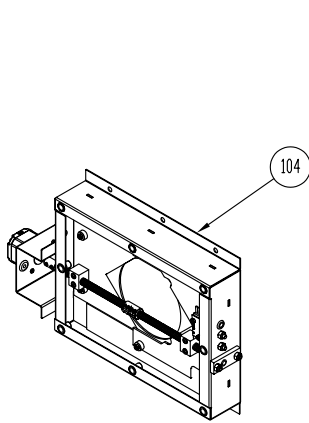
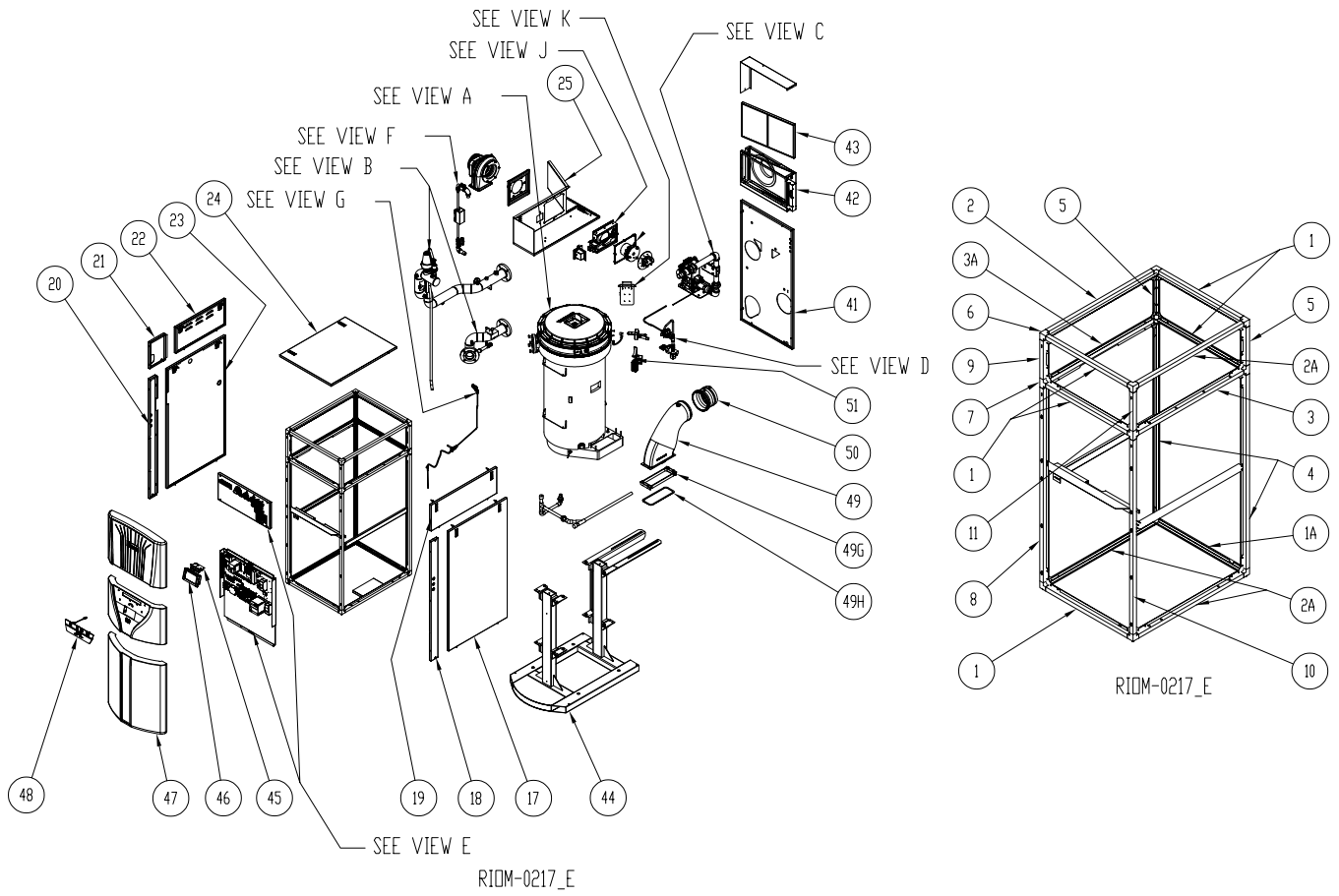

Figure 24 Continued - Single Unit Replacement Parts

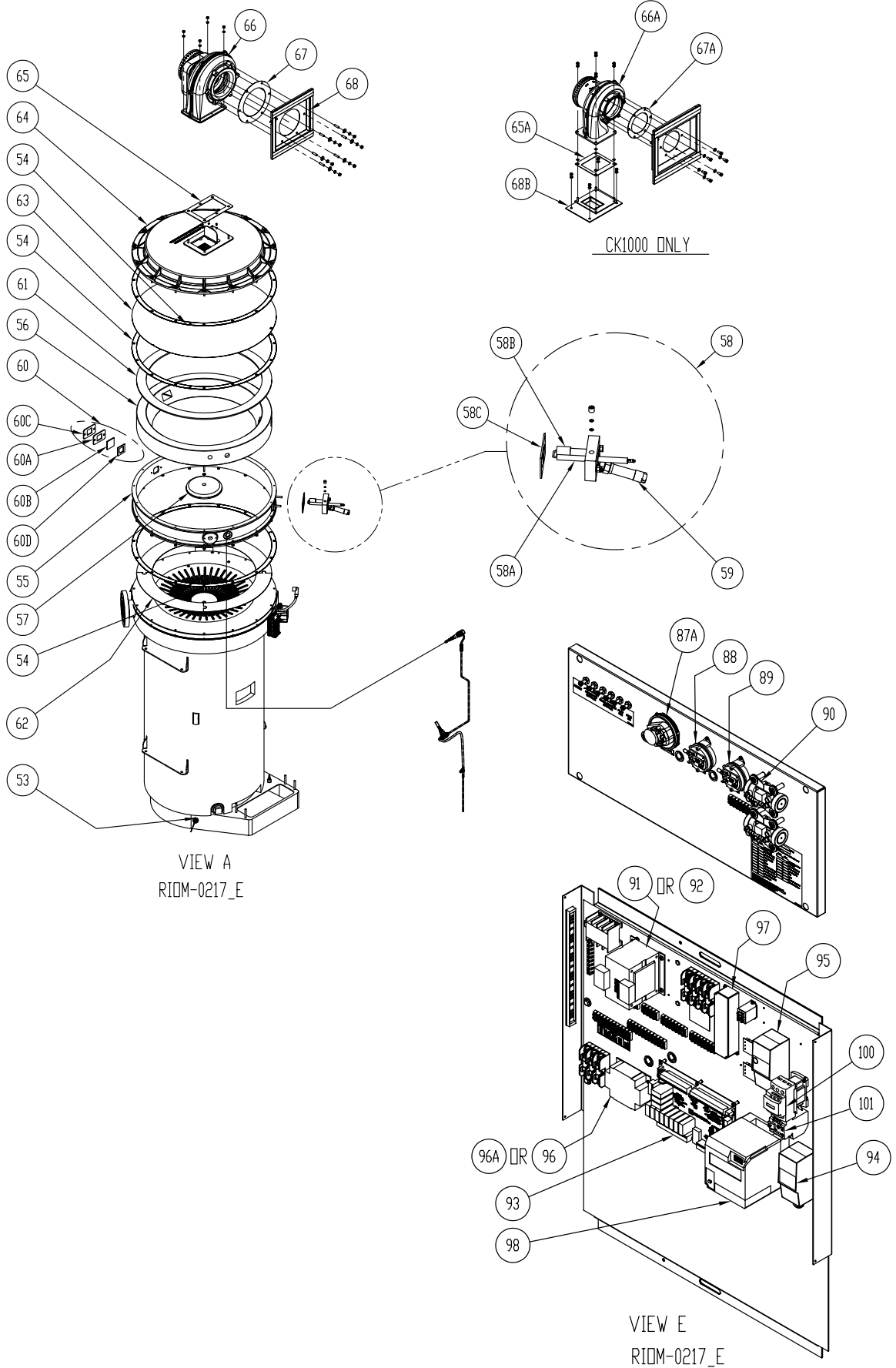
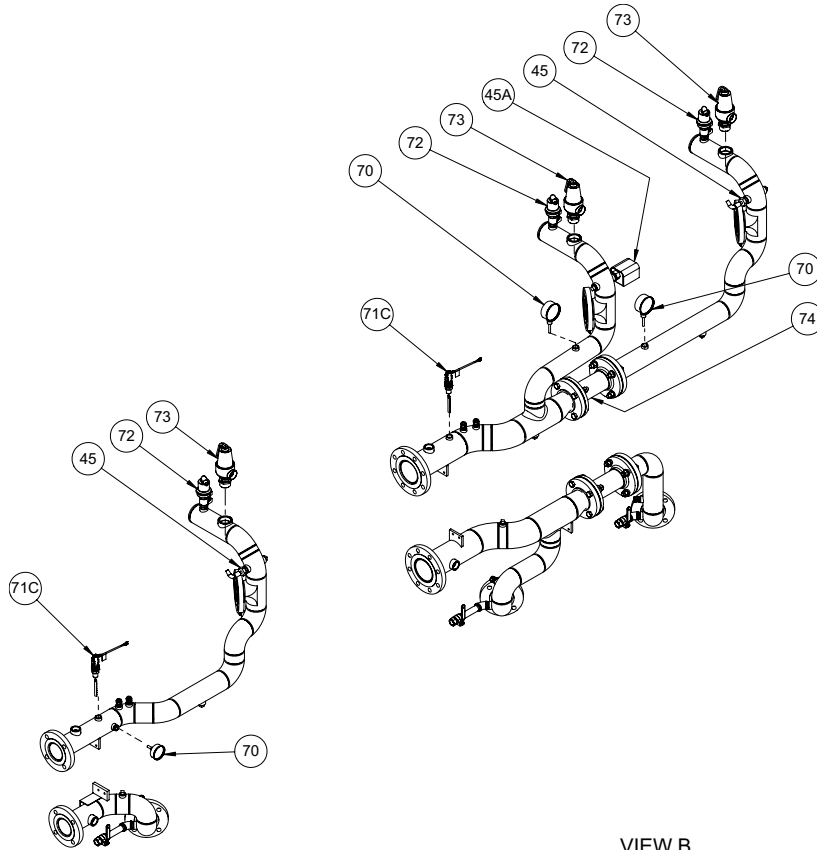
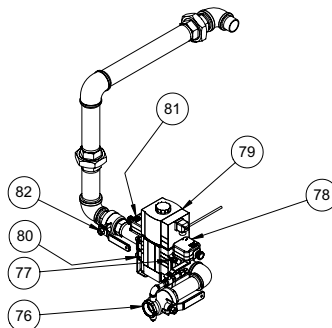
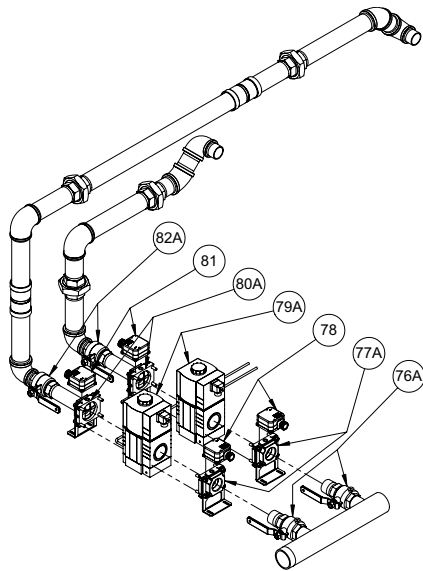

Figure 24 Continued - Single Unit Replacement Parts



VIEW B
RIOM-0217_D



VIEW C
RIOM-0217_D

Figure 24 Continued - Single Unit Replacement Parts

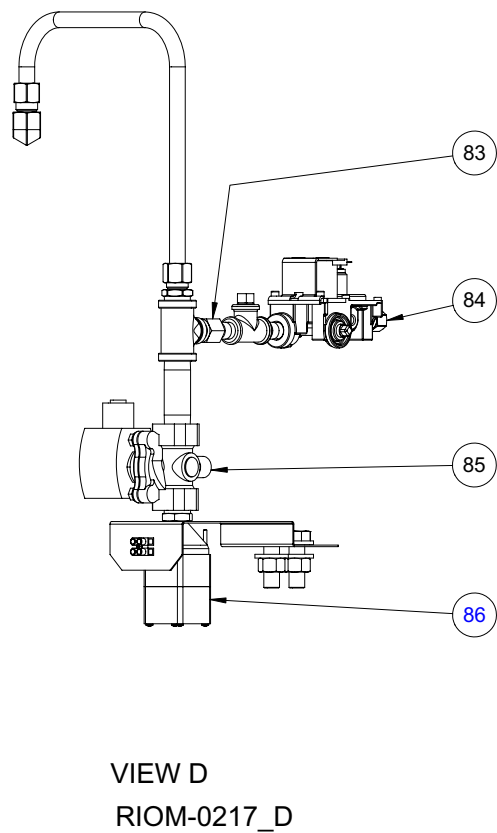
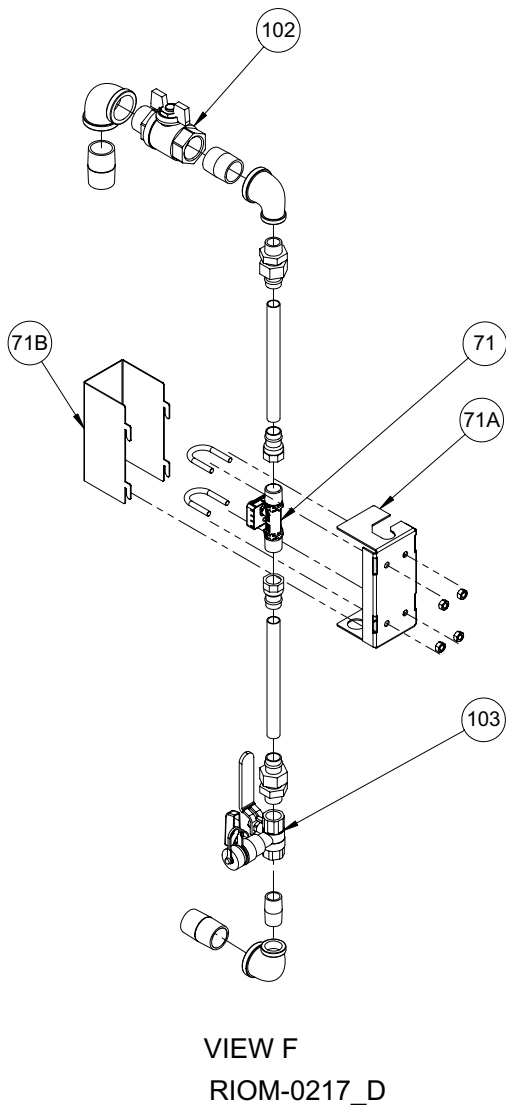

FlexCore Stainless Steel Condensing Boilers – Installation Manual

FlexCore Parts List

Ref #	Name of Part	Part No.	1000	1500	2000	2500	3000	3500	4000	4500	5000	6000
15	LH Front Panel Bracket	74-0017-001						1	1	1	1	1
16	RH Front Panel Bracket	74-0017-002						1	1	1	1	1
17	RH Front Lower Access Panel	75-0029-006	1	1	1	1	1					
17A		75-0029-007						1	1	1	1	1
17B	RH Rear Lower Access Panel	75-0029-008						1	1	1	1	1
18	RH Electrical Jacket Panel	03-4521-002	1	1	1	1	1	1	1	1	1	1
19	RH Upper Access Jacket Panel	75-0028-004	1	1	1	1	1	1	1	1	1	1
19A		75-0028-005						1	1	1	1	1
20	LH Electrical Jacket Panel	03-4521-001	1	1	1	1	1	1	1	1	1	1
21	Relief Valve Jacket Panel	03-4520-001	1	1	1	1	1	1	1	1	1	1
22	LH Upper Access Jacket Panel	75-0028-001	1	1	1	1	1	1	1	1	1	1
22A		75-0028-002						1	1	1	1	1
23	LH Front Lower Access Jacket Panel	75-0029-001	1	1	1	1	1					
23A		75-0029-002						1	1	1	1	1
23B	LH Rear Lower Access Jacket Panel	75-0029-003						1	1	1	1	1
24	Top Jacket Panel	75-0027-001	1	1	1	1	1					
24A		75-0027-002						1	1	1	1	1
24B		75-0027-003						1	1	1	1	1
NS	Latch	20-0046	2	2	2	2	2	2	2	2	2	2
25	Air Box Panel	74-0015-001	1	1	1	1	1					
25A	Front Air Box Panel	74-0015-002						1	1	1	1	1
25B	Rear Air Box Panel	74-0015-003						1	1	1	1	1
33	Air Box Splice Panel	74-0022-001						1	1	1	1	1
41	Rear Jacket Panel	75-0049-001	1	1	1	1	1					
41A		75-0049-002						1	1	1	1	1
NS	Drain Valve	11-0461	1	1	1	1	1	2	2	2	2	2
NS	Condensate Trap	74-0007-001	1	1	1	1	1					
		74-0007-002						1	1	1	1	1
NS	Filter Box Cover	74-0019-001	1	1	1	1	1					
		74-0019-002						1	1	1	1	1
42	Filter Box Assembly	75-0018-001	1									
		75-0018-002		1								
		75-0018-003			1	1	1					
42A		75-0018-004						1		1		
		75-0018-005							1		1	1
43	Combustion Air Filter	09-0494-001	1	1	1	1	1					
43A		09-0494-002						1	1	1	1	1
NS	Grommet 1"	06-0070	1									
	Grommet 1 1/2"	06-0072		1				1		1		
	Grommet 2"	06-0073			1	1	1	1	2	1	2	2
45	LWCO Board	14-0258	1	1	1	1	1	1	1	1	1	1
	LWCO Probe	14-0275	1	1	1	1	1	1	1	1	1	1
45A	LWCO, RB-122-E	14-0259						1	1	1	1	1
46	Display Board (Touchscreen)	40-0091-002	1	1	1	1	1	1	1	1	1	1
NS	Display Cable 35"	40-0115-001	1	1	1	1	1					
	Display Cable 41"	40-0115-002						1	1	1	1	1
NS	Cable, SATA 7 pin	48-0705-005						1	1	1	1	1
47	Top Front Jacket Panel	75-0032-001	1	1	1	1	1	1	1	1	1	1
	FlexCore Overlay	82-0520-001	1	1	1	1	1	1	1	1	1	1
	Center Front Jacket Panel for Touchscreen Enclosure	75-0033-002	1	1	1	1	1	1	1	1	1	1
	HeatNet/RBI Overlay for Touchscreen Enclosure	82-0751-002	1	1	1	1	1	1	1	1	1	1
	Bottom Front Jacket Panel	75-0035-001	1	1	1	1	1	1	1	1	1	1
48	Single Fuel Switch Panel Assembly	75-0015-001	1	1	1	1	1	1	1	1	1	1
NS	Switch Panel Overlay	82-0752-001	1	1	1	1	1	1	1	1	1	1
	Switch, Red	48-0013	1	1	1	1	1	1	1	1	1	1
	Switch, Green	48-0016	2	2	2	2	2	2	2	2	2	2
49	Molded Flue Outlet	09-0601-001	1	1	1	1	1					
49A	Molded Front Flue Outlet	09-0601-002						1	1	1	1	1
49B	Molded Rear Flue Outlet	09-0601-003						1	1	1	1	1
49E	Flue Outlet Expansion Joint	09-0675-001						1	1	1	1	1
49F	LH Flue Outlet Expansion Joint Clamp	74-0031-001						2	2	2	2	2
	Flue Outlet Expansion Joint Clamp	03-4583-002						4	4	4	4	4
49G	Flue Outlet Retainer	04-1471-001	2	2	2	2	2	4	4	4	4	4
	Flue Outlet Retainer Clamp	04-1484-001	2	2	2	2	2	4	4	4	4	4
49H	4 Bolt Flue Outlet Gasket	06-0208-002	1	1	1	1	1	1	2	1	2	2
50	Flue Adapter	09-0310-001	1									
		09-0310-002		1	1							
		09-0310-003				1	1					
		09-0310-004						1	1	1		
		09-0310-005									1	1
51	Spark Generator	16-0036	1	1	1	1	1	1	1	1	1	1

FlexCore Stainless Steel Condensing Boilers – Installation Manual

Ref #	Name of Part	Part No.	1000	1500	2000	2500	3000	3500	4000	4500	5000	6000	
52	Heat Exchanger	74-0005-005	1										
		74-0005-001		1				1		1			
		74-0005-002			1			1	2				
		74-0005-003				1						2	
		74-0005-004					1			1			2
52	Heat Exchanger Assembly (must order gasket kit seperately)	75-0102-001	1										
		75-0102-002		1				1		1			
		75-0102-003			1			1	2				
		75-0102-004				1						2	
		75-0102-005					1			1			2
52A	HX Gasket Kit	75-0103-001	1										
		75-0103-002		1				1		1			
		75-0103-003			1	1	1	1	2	1	2	2	
NS	High Temp Fiberglass Wrap	05-0112-7200	1	1				1		1			
		05-0112-8400			1	1	1	1	2	1	2	2	
NS	H/E Sensor, P10K-18042302	14-0331-002	1	1	1	1	1	2	2	2	2	2	
	H/E Sensor, P10K-18042301 (Dual)	14-0331-001	1	1	1	1	1	2	2	2	2	2	
53	Float Switch, LS-7-10	48-0015	1	1	1	1	1	2	2	2	2	2	
54	Burner & Combustion Chamber Gasket	06-0206-001	9	9				9		9			
		06-0206-002			9	9	9	9	18	9	18	18	
55	Combustion Chamber Casting, Small	01-0061-002	1	1				1		1			
	Combustion Chamber Casting, Large	01-0062-002			1	1	1	1	2	1	2	2	
56	Combustion Chamber, Small	05-0401-001	1	1				1		1			
	Combustion Chamber, Large	05-0401-002			1	1	1	1	2	1	2	2	
57	Ceramic Shield	05-0421-001	1	1	1	1	1	2	2	2	2	2	
	Ceramic Shield Plug	05-0421-002	1	1	1	1	1	2	2	2	2	2	
58	Long Pilot Assembly	75-0010-001	1	1				1		1			
	Short Pilot Assembly	75-0010-002			1	1	1	1	2	1	2	2	
58A	Ignitor Rod	16-0304	1	1	1	1	1	2	2	2	2	2	
58B	Long Pilot Tube	74-0011-001	1	1				1		1			
	Short Pilot Tube	74-0011-002			1	1	1	1	2	1	2	2	
59	Minipeeper	16-0009	1	1	1	1	1	2	2	2	2	2	
60A	Viewport Outer Gasket	05-0503	1	1	1	1	1	2	2	2	2	2	
60B	Viewport Glass	20-0005	1	1	1	1	1	2	2	2	2	2	
60C	Viewport Glass Retainer Plate	04-1469-001	1	1	1	1	1	2	2	2	2	2	
60D	Viewport Inner Gasket	05-0502	1	1	1	1	1	2	2	2	2	2	
61	Burner to Combustion Chamber Gasket (3 pcs per set)	05-0501-001	1	1				1		1			
		05-0501-002			1	1	1	1	2	1	2	2	
62	Combustion Chamber to HX Gasket (4 pcs per set)	05-0505-001	1	1				1		1			
		05-0505-002			1	1	1	1	2	1	2	2	
63	Burner & Distribution Plate	74-0009-001	1										
		74-0009-002		1				1		1			
		74-0009-003			1	1	1	1	2	1	2	2	
64	Upper Cover Casting	01-0212-002	1	1				1		1			
		01-0213-002			1	1	1	1	2	1	2	2	
65	Blower to Upper Cover Gasket	06-0209		1	1	1	1	2	2	2	2	2	
65A	Blower to Blower Adapter Gasket	06-0213-001	1										
66	Blower, 12.3 SO	12-0025-001K		1	1								
	Blower, 12.3 HO 208/230	12-0026-001K				1	1	2	2	2	2	2	
	Blower, 12.3 HE 460/575	12-0030-001K		1	1	1	1	2	2	2	2	2	
66A	Blower, 8.9 HO	12-0032-001K	1										
67	Blower to Air Box Adapter Gasket	06-0210-002		1	1	1	1	2	2	2	2	2	
67A	Blower to Air Box Adapter Gasket	06-0210-001	1										
68	Blower to Air Box Adapter	74-0030-002		1	1	1	1	2	2	2	2	2	
68A	Blower to Air Box Adapter	74-0030-001	1										
68B	Blower to Upper Cover Adapter	74-0029-001	1										
69	Air & Gas Mixing Box Gasket	06-0214-001	1	1	1	1	1	2	2	2	2	2	
70	T&P Gauge Duplex 0-230PSI	13-0305	1	1	1	1	1						
	T&P Gauge Duplex 0-100PSI	13-0308	1	1	1	1	1						
	T&P, 30-50PSI	13-0309						2	2	2	2	2	
	T&P, 75-125PSI	13-0310						2	2	2	2	2	
71	Flow Sensor	14-0330-002	1	1	1	1	1	1	1	1	1	1	
	Flow Sensor, Kit	75-0109-001	1	1	1	1	1	1	1	1	1	1	
71A	Flow Sensor Enclosure Base	03-4580-001	1	1	1	1	1	1	1	1	1	1	
71B	Flow Sensor Enclosure Cover	03-4582-001	1	1	1	1	1	1	1	1	1	1	
71C	Flow Switch (prior to 1018)	14-0207	1	1	1	1	1	1	1	1	1	1	
72	Air Vent	13-0352-001	1	1	1	1	1	2	2	2	2	2	
73	Pressure Relief Valve, 50#	30-0374	1										
		30-0379		1				1		1			
		13-0002			1			1	2				
		30-0369				1						2	
		30-0382						1			1		2

FlexCore Stainless Steel Condensing Boilers – Installation Manual

Ref #	Name of Part	Part No.	1000	1500	2000	2500	3000	3500	4000	4500	5000	6000
74	Braided Expansion Connector, 3"	53-5051-003						1	1	1	1	1
76	Ball Valve, 1/4 NPT Side Ports, 1 NPT	11-0465	1									
76A	Ball Valve, 1/4 NPT Side Ports, 1 1/2 NPT	11-0467		1	1	1	1	2	2	2	2	2
77	Flange, Adjustable Shutter, 1 NPT	11-0228	1									
77A	Flange, Adjustable Shutter, 1 1/2 NPT	11-0229		1	1	1	1	2	2	2	2	2
78	Low Gas Pressure Switch	11-0422	1	1	1	1	1	2	2	2	2	2
79	Valve MBC 1000	11-0230	1									
79A	Valve MBC 2500	11-0227		1	1	1	1	2	2	2	2	2
80	Flange 1"	11-0231	1									
80A	Flange 1 1/2"	11-0214		1	1	1	1	2	2	2	2	2
81	High Gas Pressure Switch	11-0421	1	1	1	1	1	2	2	2	2	2
82	Ball Valve 1"	11-0456	1									
82A	Ball Valve 1 1/2"	11-0458		1	1	1	1	2	2	2	2	2
83	Pilot Orifice, NG, 0.063" ID	10-0140-003	1	1	1	1	1	2	2	2	2	2
84	Pilot Gas Valve	11-0079	1	1	1	1	1	2	2	2	2	2
85	Pilot Air Solenoid Valve	11-0376-002	1	1	1	1	1	2	2	2	2	2
86	Mini Fan	12-0021-002	1	1	1	1	1	2	2	2	2	2
87	Pressure Switch, Blower Prove, 0.20" WC (5:1 option only)	14-0067	1	1	1	1	1	2	2	2	2	2
87A	Pressure Switch, Blower Prove, 0.40" WC (10:1 option only)	14-0072-001	1	1	1	1	1					
88	Pressure Switch, Blocked Flue, 2.5" WC	14-0068	1	1	1	1	1	1	1	1	1	1
89	Pressure Switch, Blocked Inlet, 3.0" WC	14-0069	1	1	1	1	1	2	2	2	2	2
90	Air Pump	12-0027	1	1	1	1	1	1	1	1	1	1
91	Transformer, 50VA	15-0007	1	1	1							
92	Transformer, 500VA	15-0040-002				1	1					
92A	Transformer, 500VA	15-0040-002						1	1	1	1	1
93	HeatNet Control, V3.0, Full Version, w/SATA	40-0092	1	1	1	1	1	2	2	2	2	2
	HeatNet 3.0 Replacement Kit, Full Version w/SATA	75-0401-003	1	1	1	1	1	2	2	2	2	2
NS	Ignition Cable	44-0063	1	1	1	1	1	1	1	1	1	1
NS	Plug, 220 OHM, Black	40-0079-001						1	1	1	1	1
94	High Limit, Auto Reset	14-0115	1	1	1	1	1	1	1	1	1	1
95	High Limit, Manual Reset	14-0127	1	1	1	1	1	1	1	1	1	1
96	Solid State Relay, 25A, 3PH	15-0142-001			2	2	2	2	2	2	2	2
96A	Solid State Relay, 20A, 1PH	15-0137	1	1	1	1	1					
97	Power Supply, 120VAC Primary, 12VDC Secondary	15-0352-002	1	1	1	1	1	1	1	1	1	1
98	Burner Control, 7800 Series	16-0065-001	1	1	1	1	1	2	2	2	2	2
NS	Base, Q7800	16-0068-001	1	1	1	1	1	2	2	2	2	2
NS	Keyboard Display Module, S7800A	16-0067-001	1	1	1	1	1	2	2	2	2	2
NS	Purge Timer, ST7800	16-0007	1	1	1	1	1	2	2	2	2	2
NS	UV Amplifier, R7849B	16-0037	1	1	1	1	1	2	2	2	2	2
102	Ball Valve, T-Handle	11-0471-003	1	1	1	1	1	1	1	1	1	1
103	Ball Valve	13-0252-001	1	1	1	1	1	1	1	1	1	1
NS	Harness Kit	40-0501	1	1	1	1	1					
		40-0501-002						1	1	1	1	1
104	Assembly, Shutter Box	75-0058-001	1	1	1	1	1					
NS	Gasket, Shutter Box Cover	06-0220-001	1	1	1	1	1					
NS	Gasket, Shutter Box to Air Box	06-0221-001	1	1	1	1	1					
NS	Shutter Box Replacement Kit (Return Policy Required)	75-0406-001	1	1	1	1	1					
105	O2 Sensor	16-0341	1	1	1	1	1	2	2	2	2	2
106	Delta-T Board	40-0078	1	1	1	1	1	2	2	2	2	2
107	High Turn Down Board	40-0080-001	1	1	1	1	1	2	2	2	2	2
108	Power Supply, 120VAC Primary, 2X 12VDC Secondary	15-0353-001	1	1	1	1	1	1	1	1	1	1
NS	Heat Exchanger Protection Sensor	14-0331-002	1	1	1	1	1	2	2	2	2	2
NS	Supply Sensor	14-0331-001	1	1	1	1	1	2	2	2	2	2
NS	Return Sensor	40-0421-001	1	1	1	1	1	1	1	1	1	1
		40-0421-002						1	1	1	1	1
NS	Common Sensor	40-0421-004						1	1	1	1	1
NS	Cover Plate, Optical Sensor (5:1 and 10:1 option only)	03-4609-001	1	1	1	1	1	2	2	2	2	2
NS	Gasket, Optical Sensor Cover Plate (5:1 and 10:1 option only)	05-0509-001	1	1	1	1	1	2	2	2	2	2
NS	Gasket, Optical Sensor Cover Plate (5:1 and 10:1 option only)	05-0509-001	1	1	1	1	1	2	2	2	2	2

START-UP REPORT

DATE:	JOB NAME:
TECHNICIAN:	LOCATION:
COMPANY:	MODEL:
PHONE NUMBER:	SERIAL #:

PRE-STARTUP CHECK LIST

- | | |
|--|--|
| <input type="checkbox"/> NO VISIBLE DAMAGE TO UNIT | <input type="checkbox"/> INLET AIR FILTER INSTALLED AND CLEAN |
| <input type="checkbox"/> PIPING PROPERLY CONNECTED | <input type="checkbox"/> PROPER SERVICE CLEARANCES PROVIDED |
| <input type="checkbox"/> BOILER CIRCULATOR WIRED | <input type="checkbox"/> PUMP RUNNING, HEAT EXCHANGER FULL |
| <input type="checkbox"/> VENT/STACK CONNECTED | <input type="checkbox"/> GAS LINES PURGED, NO LEAKS, NO MISSING TEST PLUGS |

BOILER START UP SEQUENCE

Note: Locate the S2 Calibration Switch and low fire hold switch in the bottom-right of the electrical panel on the main HeatNet board. Also locate the manometer test ports at the bottom of the filter box.

1. Perform pre-start up checks and set up: (follow section "Operating Instructions"; Steps 1-10).
2. Disable any external call for heat and toggle the remote/local switch to REMOTE (follow section "Operating Instructions"- selected turndown procedure).
3. Ignition and pilot adjustment: Toggle the LOW FIRE switch to cycle the boiler then hold at trial for pilot ignition (follow section "Operating Instructions"- selected turndown procedure).
4. Set pilot pressure (follow section "Checking, Adjustment & Operation") (flame signal should read 5.0 VDC).
5. Set low and high fire combustion values; (follow section "Operating Instructions"- selected turndown procedure).
6. Record low and high fire combustion values (page 2 of Start-up Report).
7. Check all combustion results using a calibrated flue gas analyzer
8. Release the LOW FIRE switch to place boiler in standby.

NOTICE In addition to completing the FlexCore Series start-up report, complete the control set-up information in the rear of the HeatNet manual.

FlexCore Stainless Steel Condensing Boilers – Installation Manual

COMBUSTION ANALYSIS	MINIMUM FIRING RATE	100% FIRING RATE
GAS INLET PRESSURE (WC)	INCHES WC	INCHES WC
CO ₂	%	%
O ₂	%	%
CO (PPM)	PPM	PPM
NET STACK TEMPERATURE	°F	°F
SIGNAL PRESSURE (DELTA P - WC)	INCHES WC	INCHES WC
AIR SHUTTER (DELTA P - WC)	INCHES WC	N/A
MIN AIR SHUTTER CALIBRATION	%	N/A
BLOWER CLAMP CALIBRATION	%	N/A
MAXIMUM CALIBRATION	N/A	%
TACHOMETER	RPM	RPM

SAFETY TEST CHECKLIST

- | | | |
|--|--------------------------------------|--|
| <input type="checkbox"/> FLOW SWITCHES (By Others) | <input type="checkbox"/> AIR SWITCH | <input type="checkbox"/> FLAME SAFEGUARD |
| <input type="checkbox"/> LOW WATER CUT-OFF | <input type="checkbox"/> HIGH LIMITS | |

COMMISSIONING THE BOILER

<input type="checkbox"/> UNIT CYCLED MINIMUM OF 15 TIMES <input type="checkbox"/> CUSTOMER INSTRUCTED <input type="checkbox"/> ALL COVERS REPLACED <input type="checkbox"/> CUSTOMER GIVEN MANUAL <input type="checkbox"/> TARGET TEMPERATURE SET PER CUSTOMER COMMISSIONED BY: _____ <div style="text-align: right;">(SIGNATURE)</div> DATE: _____	THE DELTA T BETWEEN THE HEATER INLET AND OUTLET IS CRITICAL TO PROPER FLOW. BEFORE YOU LEAVE THE JOB-SITE, YOU MUST RECORD THE DELTA T. THIS READING SHOULD NOT EXCEED 100°F, 55°C, NOR BE LOWER THAN 20°F, 11.1°C. DELTA T = <input style="width: 100px; height: 20px;" type="text"/>
--	---

NOTICE The Flexcore boiler input will automatically derate at elevations above 1000 ft. Units are equipped to adjust to rated inputs at elevations up to 6000 ft. Higher elevations will derate by approximately 4% for each 1000 ft above 6000 ft. (No hardware changes are required for installations up to 10,000 ft).

ADDITIONAL NOTES AND COMMENTS

NOTICE!

Commonwealth of Massachusetts Installation Requirements

(a) For all side wall horizontally vented gas fueled equipment installed in every dwelling, building or structure used in whole or in part for residential purposes, including those owned or operated by the commonwealth and where the side wall exhaust vent termination is less than seven (7) feet above finished grade, in the area of the venting, including but not limited to decks and porches, the following requirements shall be satisfied:

1. **INSTALLATION OF CARBON MONOXIDE DETECTORS.**
At the time of installation of the side wall horizontal vented gas fueled equipment, the installing plumber or gasfitter shall observe that a hard wired carbon monoxide detector with an alarm and battery back-up is installed on the floor level where the gas equipment is to be installed. In addition, the installing plumber or gasfitter shall observe that a battery operated or hard wired carbon monoxide detector with an alarm is installed on each additional level of the dwelling, building or structure served by the side wall horizontal vented gas fueled equipment. It shall be the responsibility of the property owner to secure the services of qualified licensed professionals for the installation of hard wired carbon monoxide detectors.
 - a. In the event that the side wall horizontally vented gas fueled equipment is installed in a crawl space or an attic, the hard wired carbon monoxide detector with alarm and battery back-up may be installed on the next adjacent floor level.
 - b. In the event that the requirements of this subdivision can not be met at the time of completion of installation, the owner shall have a period of thirty (30) days to comply with the above requirements; provided, however, that during said thirty (30) day period, a battery operated carbon monoxide detector with an alarm shall be installed.
2. **APPROVED CARBON MONOXIDE DETECTORS.** Each carbon monoxide detector as required in accordance with the above provisions shall comply with NFPA 720 and be ANSI/UL 2034 listed and IAS certified.
3. **SIGNAGE.** A metal or plastic identification plate shall be permanently mounted to the exterior of the building at a minimum height of eight (8) feet above grade directly in line with the exhaust vent terminal for the horizontally vented gas fueled heating appliance or equipment. The sign shall read, in print size no less than one-half (1/2) inch in size, "GAS VENT DIRECTLY BELOW. KEEP CLEAR OF ALL OBSTRUCTIONS".
4. **INSPECTION.** The state or local gas inspector of the side wall horizontally vented gas fueled equipment shall not approve the installation unless, upon inspection, the inspector observes carbon monoxide detectors and signage installed in accordance with the provisions of 248 CMR 5.08(2)(a)1 through 4.

⚠WARNING Improper venting can result in excessive levels of carbon monoxide which can cause severe personal injury or death!

In the Commonwealth of Massachusetts, the installation must be performed by a licensed plumber or gas fitter.

(b) Exemptions

The following equipment is exempt from 248 CMR 5.08(2)(a) 1 through 4:

1. The equipment listed in Chapter 10 entitled "Equipment Not Required To Be Vented" in the most current edition of NFPA 54 as adopted by the Board; and
2. Product Approved side wall horizontally vented gas fueled equipment installed in a room or structure separate from the dwelling, building or structure used in whole or in part for residential purposes.

(c) MANUFACTURER REQUIREMENTS - GAS EQUIPMENT VENTING SYSTEM PROVIDED.

When the manufacturer of Product Approved side wall horizontally vented gas equipment provides a venting system design or venting system components with the equipment, the instructions provided by the manufacturer for installation of the equipment and the venting system shall include:

1. Detailed instructions for the installation of the venting system design or the venting system components; and
2. A complete parts list for the venting system design or venting system.

(d) MANUFACTURER REQUIREMENTS – GAS EQUIPMENT VENTING SYSTEM NOT PROVIDED.

When the manufacturer of a Product Approved side wall horizontally vented gas fueled equipment does not provide the parts for venting the flue gases, but identifies "special venting systems", the following requirements shall be satisfied by the manufacturer:

1. The referenced "special venting system" instructions shall be included with the appliance or equipment installation instructions; and
2. The "special venting systems" shall be Product Approved by the Board, and the instructions for that system shall include a parts list and detailed installation instructions.

(e) A copy of all installation instructions for all Product Approved side wall horizontally vented gas fueled equipment, all venting instructions, all parts lists for venting instructions, and/or all venting design instructions shall remain with the appliance or equipment at the completion of the installation.

⚠WARNING Improper venting can result in excessive levels of carbon monoxide which can cause severe personal injury or death!

FlexCore Series Water Boiler Limited Warranty

The specific company or business unit that manufactured the products purchased ("Manufacturer") warrants exclusively to the original owner at the original installation site (hereinafter "Owner") that the parts comprising the Flexcore Series modulating water boiler ("Product") FlexCore Series modulating water boiler including the heat exchanger provided therein in and the parts comprising the FlexCore Series Boiler (collectively "Products") will be free from defects in material and workmanship for the periods set forth below in the Warranty Effective Periods A, B, and C. All warranty claims are subject to, and contingent upon, Owner following the terms of the Warranty claim service procedure set forth below as well as the specific Product requirements set forth in the Warranty Effective periods A, B and C below. Failure to do shall void the warranty.

Warranty claim service procedure

1. Owner must first obtain a Return Material Authorization ("RMA") from the manufacturer before returning any Products.
2. Products must be returned to the Manufacturer at Owner's expense, including packaging, transportation and any applicable VAT and import duty costs, and risk of loss or damage to the manufacturer's factory set forth when obtaining the RMA.
3. Manufacturer shall evaluate the returned Products purported to be defective due to defects in material or Manufacturer's workmanship and will determine in its reasonable and sole discretion if indeed such defects have occurred.
4. If indeed the Product is determined to be defective due to defects in material or Manufacturer's workmanship, Manufacturer shall either repair or replace, at its option, the Product.
5. Repaired or replacement Products shall be returned to Owner on an EXW (Ex Works basis, Incoterms 2020 or current version) at Owner's expense and risk.
6. The repaired or replacement Products returned to Owner shall be warranted only for the remainder of the original warranty effective period and the repair or replacement of Product shall not extend the effective period of the original warranty on the Product.

Warranty Effective Periods/ Product Requirements

A. One-Year Warranty

The "Manufacturer" warrants to the Owner that the parts comprising the Flexcore Series modulating water boiler ("Product") will be free from defects in material and workmanship for one (1) year from the date of installation or eighteen (18) months from the date of shipment from the factory whichever comes first except where otherwise noted herein below.

B. Ten-Year Warranty

The manufacturer further warrants to the Owner that the Heat Exchanger provided in the Boiler Products will be free from defects from condensate corrosion and in material and workmanship for a period of **either** ten (10) years (non prorated) from the date of installation or one hundred twenty-six (126) months from the date of shipment from the factory, whichever occurs first provided that (i) Suspended solids such as magnetite, Iron Oxides were flushed from the system prior to commissioning the boiler(s), (ii) The system fill water did not at any time contain more than 500 ppm of dissolved solids, did not contain less than 150 ppm chloride concentration and was not greater than 300 ppm hardness, (iii) the PH level must be, and have been, at all times, within 6.5-10 range, (iv) the system has been protected by the addition of a corrosion inhibitor where required by either the chemical supplier's or manufacturer's instructions, (v) A minimum system pressure of (20 psig, 138, kPa) has been maintained at boiler operating conditions - (30 psig, 207 kPa is required for glycol systems) and (vi) for systems that require glycol for freeze protection, the use of a glycol/water mix that prevents foaming is mandatory because air entrapped within foam significantly decreases heat transfer and can result in damage to the heat exchanger. Coalescing style air separators are strongly recommended in Variable Speed Systems where velocities can vary and may be too slow for conventional type air separators. Failure to follow any of these requirements will void the warranty.

C. Twenty-One Year Thermal Shock Warranty

The manufacturer further warrants to the Owner that the Heat Exchangers in the Products will be warranted for twenty-one (21) years against thermal shock when installed in a closed loop hot water system. This warranty does not cover damage due to corrosion, scaling, sooting or to improper installation practices as set forth in the Exclusions to the Limited Warranty below. The inlet / outlet temperature differential across the boiler heat exchanger must not exceed 100 degrees F. Failure to follow these guidelines will void the warranty.

Exclusions to This Limited Warranty all exclusions will be determined in the sole discretion of Manufacturer:

- a. Any expenses, including manufacturer's on-site labor or material, incurred during the removal or reinstallation of the product or replacement parts thereof all of which are the responsibility of the Owner.
- b. Products that have been subjected to misuse or neglect, have been accidentally or intentionally damaged, has not been installed, maintained or operated in accordance with the manufacturer's furnished written instructions or manuals, or has been altered or modified in anyway by any person other than those authorized in writing by the Manufacturer to do so. Chemical corrosion from corrosive chemicals (freon, dry cleaning chemicals, degreasing liquids, chlorine or any chemicals that produce hydrochloric acid) that may be present in the boiler room can rapidly destroy the heating equipment and void the warranty.
- c. Products that were not properly installed, maintained (serviced annually) or operated by a qualified contractor in accordance with the Manufacturer's furnished written instructions, or meet the good practice as defined by the industry's accepted authority, or were altered or modified in anyway by any person other than those authorized in writing by the Manufacturer to do so.
- d. To burners, jackets, controls and other auxiliary equipment furnished by the manufacturer, but manufactured by others. Any warranties for such items shall be limited to those warranties offered by the original equipment manufacturer.
- e. Damage associated with or caused by the installation of the Products regardless of whether the installer, provided by the Owner, is considered, or was authorized by Manufacturer, to be a qualified contractor, to perform the installation. The installation contractor is solely and exclusively responsible to the Owner for its own work and the results thereof.

THIS LIMITED WARRANTY IS THE EXCLUSIVE WARRANTY TO THE FLEXCORE SERIES WATER BOILERS AND IS IN LIEU OF ALL OTHER WARRANTIES, EXPRESS OR IMPLIED, OF ANY KIND AND SUPERSEDES ALL OTHER WARRANTIES, INCLUDING THOSE CONTAINED IN OTHER DOCUMENTS WHICH MIGHT HAVE BEEN INCLUDED WITH THE PRODUCTS OR BOILERS AT THE TIME OF SHIPMENT. THE REMEDIES UNDER THIS WARRANTY ARE EXCLUSIVE TO THE ORIGINAL OWNER ("OWNER") AT THE ORIGINAL PLACE OF INSTALLATION AND MANUFACTURER NEITHER ASSUMES NOR AUTHORIZES ANYONE TO OFFER OR ASSUME FOR IT ANY OTHER OBLIGATIONS. THIS WARRANTY GIVES OWNER SPECIFIC LEGAL RIGHTS HOWEVER IN NO EVENT SHALL MANUFACTURER BE LIABLE FOR ANY DIRECT DAMAGES THAT EXCEED THE ORIGINAL SALE PRICE OF THE PRODUCTS SOLD TO OWNER THAT ARE FOUND TO BE DEFECTIVE, SPECIAL, INDIRECT, CONSEQUENTIAL, PUNITIVE OR INCIDENTAL DAMAGES OF ANY KIND, OR ON-SITE LABOR, EXPENSES OF ANY KIND, LOST PROFITS, LOST OPPORTUNITIES, OR SIMILAR DAMAGES OF ANY KIND; AND REGARDLESS OF THE LEGAL THEORY OR CAUSES OF ACTION BY WHICH CLAIMS FOR ANY SUCH DAMAGES AS SET FORTH IN THE ENTIRETY OF THE DOCUMENTS RELATED TO THE SALE OF THE BOILER CONTRACT ARE ADVANCED, WHETHER OR NOT MANUFACTURER HAS BEEN ADVISED OF THE POSSIBILITY OF ANY SUCH DAMAGES.



260 North Elm Street
Westfield, MA 01085
Phone: (833) 265-5371

7555 Tranmere Drive
Mississauga, Ontario L5S 1L4 Canada
Phone: (905) 670-5888

www.rbiwaterheaters.com

