

RBI®

RELIABLE. BOLD. INNOVATIVE.



FUTERA II SERIES

Finned Copper Tube Gas Boilers (FB) & Water Heaters (FW)

Boiler Manual *Installation and Operation Instructions*

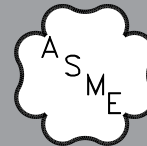

⚠️ WARNING This manual is intended only for use by a qualified heating installer/technician. Read and follow this manual, all supplements and related instructional information provided with the boiler. Install, start and service the boiler only in the sequence and methods given in these instructions. Failure to do so can result in severe personal injury, death or substantial property damage.

⚠️ WARNING **Do not use the boiler during construction.** Construction dust and particulate, particularly drywall dust, will cause contamination of the burner, resulting in possible severe personal injury, death or substantial property damage. The boiler can only be operated with a dust-free air supply. Follow the instruction manual procedures to duct air to the boiler air intake. If the boiler has been contaminated by operation with contaminated air, follow the instruction manual guidelines to clean, repair or replace the boiler if necessary.

⚠️ CAUTION Affix these instructions near to the boiler/water heater. Instruct the building owner to retain the instructions for future use by a qualified service technician, and to follow all guidelines in the User's Information Manual.

FUTERA II INSTALLATION AND OPERATION INSTRUCTIONS

CONTENTS

RATINGS & CAPACITIES.	3
BOILER/WATER HEATER LOCATION.	3
COMBUSTION AIR & VENTILATION.	3
GENERAL VENTING GUIDELINES	5
OUTDOOR VENTING	18
COMMON VENT SYSTEMS	17
GENERAL PIPING REQUIREMENTS	17
HEATING SYSTEM PIPING.	19
DOMESTIC WATER SUPPLY PIPING	23
GAS SUPPLY PIPING.	27
ELECTRICAL WIRING	28
GENERAL OPERATION.	28
OPERATING INSTRUCTIONS.	28
CHECKING & ADJUSTMENTS.	30
CONTROL DESCRIPTION.	32
DIAGNOSTIC	33
MAINTENANCE	34
TROUBLE-SHOOTING.	37
REPAIR PARTS.	37
START UP SHEET.	41
WARRANTY	44

BEFORE YOU START

This manual covers the application, installation, operation and maintenance of a Futera II Series finned copper heating boiler/water heater.

To obtain the safe, dependable, efficient operation and long life for which this heating boiler/water heater was designed, these instructions must be read, understood and followed.

The Futera II Series finned copper heating boiler/water heaters have been design certified by CSA for use with natural and propane gas under the latest revision of ANSI-Z21.10.3/CSA 4.3, Gas Water Heaters, ANSI-Z21.13/CSA 4.9, Gas-Fired Low Pressure Steam and Hot Water Boilers. Each unit has been constructed and hydrostatically tested for a maximum working pressure of **160 psi, 1103 kPa** in accordance with Section IV of the A.S.M.E. Boiler and Pressure Vessel Code.

All aspects of the boiler/water heater installation must conform to the requirements of the authority having jurisdiction, or, in the absence of such requirements, to the National Fuel Gas Code, ANSI Z223.1/NFPA 54-latest revision. Where required by the authority having jurisdiction, the installation must conform to the Standard for Controls and Safety Devices for Automatically Fired Boilers, ANSI/ASME CSD-1.

In Canada, the installation must be in accordance with the requirements of CSA B149.1 or .2, Installation Code for Gas Burning Appliances and Equipment.

The owner should maintain a record of all service work performed with the date and a description of the work done. Include the name of the service organization for future reference.

For technical assistance please contact RBI at 833-265-5371. For sales and other technical assistance contact RBI manufacturer's representative at 877-316-5074 or www.rbiwaterheaters.com. Please have model and serial number of the equipment in question available.

FUTERA II INSTALLATION AND OPERATION INSTRUCTIONS

RATINGS & CAPACITIES

Before undertaking the installation of the Futera II Series boiler/water heater check the rating plate to ensure that the unit has been sized properly for the job. The “Net Ratings” specify the equivalent amount of direct copper radiation that the unit can supply under normal conditions. Also ensure that the unit has been set up for the type of gas available at the installation site. Other important considerations are the availability of an adequate electrical supply, fresh air for combustion and a suitable chimney or vent system.

BOILER/WATER HEATER LOCATION

1. This boiler/water heater is suitable for indoor and outdoor installations. Locate the boiler/water heater in an area that provides good access to the unit. Servicing may require the removal of jacket panels. Allow the minimum clearances between adjacent construction and the boiler/water heater as listed in Table 1.

NOTE: Service clearances are not mandatory, but are recommended to ensure ease of service should it be required.

Table 1

	Clearance to Combustibles		Service Clearance	
	in	mm	in	mm
Top	24	610	30	762
Back	14	356	24	610
Left Side	6	153	12	306
Right Side	6	153	12	306
Front	8	203	30	762

2. An optimum site will be level, central to the piping system, close to a chimney or outside wall and have adequate fresh air for combustion. Ensure that the boiler/water heater is level from front to back and from side to side. Use metal shims to level the boiler/water heater. Electrical and electronic components must also be protected from exposure to water during operation and maintenance. DO NOT install this boiler/water heater in a location that would subject any of the gas ignition components to direct contact with water or excessive moisture during operation or servicing.
3. Ensure that the floor is structurally sound and will support the weight of the boiler/water heater.

NOTICE The Futera II may be installed directly on combustible flooring, but never on carpeting.

4. Locate the boiler/water heater in an area that will prevent water damage to adjacent construction should a leak occur or during routine maintenance. If such a location doesn't exist, a suitable drain pan that's adequately drained must be installed under the unit.
5. DO NOT place this boiler/water heater in a location that would restrict the introduction of combustion air into the unit or subject it to a negative pressure, see “GENERAL VENTING GUIDELINES”.

6. NEVER place this boiler/water heater in a location that would subject it to temperatures at or near freezing. See the “Freeze Protection” section on page 18.

CAUTION Units installed outdoors MUST be protected from ice and snow accumulation or the unit will be damaged voiding the warranty!

WARNING Never store combustible materials, gasoline or any product containing flammable vapors or liquids in the vicinity of the boiler/water heater. Failure to comply with this warning can result in an explosion or fire causing extensive property damage, severe personal injury or death!

COMBUSTION AIR & VENTILATION

WARNING This boiler/water heater must be supplied with combustion air in accordance with Section 5.3, Air for Combustion & Ventilation, of the latest revision of the National Fuel Gas Code, ANSI Z223.1/NFPA 54 and all applicable local building codes. Canadian installations must comply with CAN/ CGA B149.1 or .2 Installation Code for Gas Burning Appliances and Equipment, or applicable provisions of the local building codes. Failure to provide adequate combustion air for this boiler/water heater can result in excessive levels of carbon monoxide which can result in severe personal injury or death!

To operate properly and safely this boiler/water heater requires a continuous supply of air for combustion. NEVER store objects on or around the boiler/water heater!

CAUTION Combustion air contaminated with fluorocarbons or other halogenated compounds such as cleaning solvents and refrigerants will result in the formation of acids in the combustion chamber. These acids will cause premature failure of the boiler/water heater voiding the warranty!

CAUTION If the boiler/water heater is operated while the building is under construction it MUST be protected from wood, concrete, sheet rock and other types of dust. Failure to properly protect the unit from construction dust will damage the unit voiding the warranty!

Buildings will require the installation of a fresh air duct or other means of providing make-up air if the intake air option isn't used. Any building utilizing other gas burning appliances, a fireplace, wood stove or any type of exhaust fan must be checked for adequate combustion air when all of these devices are in operation at one time. Sizing of an outside air duct must be done to meet the requirements of all such devices.

FUTERA II INSTALLATION AND OPERATION INSTRUCTIONS

⚠WARNING Never operate the Futera II in an environment subjected to a negative pressure unless it is Direct Vented. Failure to comply with this warning can result in excessive levels of carbon monoxide causing severe personal injury or death!

All Air From Inside The Building

If the Futera II is to be located in a confined space, the minimum clearances listed in Table 1 must be maintained between it and any combustible construction. When installed in a confined space **without the intake air option**, Figures 7, 8 and 9, two permanent openings communicating with an additional room(s) are required. The combined volume of these spaces must have sufficient volume to meet the criteria for an unconfined space. The total air requirements of all gas utilization equipment, fireplaces, wood stoves or any type of exhaust fan must be considered when making this determination. Each opening must have a minimum free area of **1 in²/1000 Btu/hr, 2200 mm²/kW** based on the total input rating of ALL gas utilization equipment in the confined area. Each opening must be no less than **100 in², 64,516 mm²** in size. The upper opening must be within **12 in, 305 mm** of, but not less than **3 in, 76 mm** from, the top of the enclosure. The bottom opening must be within **12 in, 305 mm** of, but not less than **3 in, 76 mm** from, the bottom of the enclosure.

All Air From Outside The Building

When installed in a confined space **without utilizing the intake air option** two permanent openings communicating directly with, or by ducts to, the outdoors or spaces that freely communicate with the outdoors must be present. The upper opening must be within **12 in, 305 mm** of, but not less than **3 in, 76 mm** from, the top of the enclosure. The bottom opening must be within **12 in, 305 mm** of, but not less than **3 in, 76 mm** from, the bottom of the enclosure.

Where directly communicating with the outdoors or communicating with the outdoors through vertical ducts, each opening shall have a minimum free area of **1 in²/4000 Btu/hr, 550 mm²/kW** of the total input rating of all of the equipment in the enclosure.

Where communicating with the outdoors through horizontal ducts, each opening shall have a minimum free area of **1 in²/2000 Btu/hr, 1100 mm²/kW** of the total input rating of all of the equipment in the enclosure.

When ducts are used, they must have the same cross-sectional area as the free area of the opening to which they connect.

When calculating the free area necessary to meet the make-up air requirements of the enclosure, consideration must be given to the blockage effects of louvers, grills and screens. Screens must have a minimum mesh size of **1/4 in, 6.4 mm**. If the free area through a louver or grill is not known, ducts should be sized per Table 2.

Table 2 – Make-up Air Louver Sizing

Input (MBH)	Required Cross Sectional Area					
	1/4 in 6.4 mm Wire Screen		75% Free Area Metal Louvers		25% Free Area Wooden Louvers	
	in ²	cm ²	in ²	cm ²	in ²	cm ²
500	125	806	167	1077	500	3226
750	187	1206	250	1613	750	4839
1000	250	1613	333	2148	1000	6452
1250	313	2019	416	2684	1250	8065
1500	375	2419	500	3226	1500	9677
1750	437	2819	583	3761	1750	11,290
1950	486	3135	649	4187	1950	12,580

Canadian installations must comply with CSA B149.1 when **air supply** is provided by natural air flow from the outdoors for **natural draft**, partial fan-assisted, fan-assisted, or power draft-assisted **burners**, there shall be a permanent **air supply** opening(s) having a cross-sectional area of not less than **1 in² per 7,000 Btu/h (310 mm² per kW)** up to and including **1 million Btu/h, plus 1 in² per 14,000 Btu/h (155 mm² per kW) in excess of 1 million Btu/h.**

Intake Air Option – General Guidelines

This configuration provides combustion air directly to the boiler/water heater's air intake using a dedicated pipe when using the direct vent option. The RBI air intake adapter must be fitted to the blower inlet. Combustion air can be drawn in horizontally through the same outside wall which terminates the exhaust gases or vertically through the roof, see Figures 2, 3, 4, 5 & 6.

⚠WARNING Common intake air systems may be used provided the common duct is sized properly and an intake combustion air damper is installed in the intake air pipe of each heater. Improper installation can result in excessive levels of carbon monoxide which can cause severe personal injury or death!

All joints in metal intake air systems must be secured using corrosion resistant fasteners and sealed using a suitable Silicone caulk. If PVC or CPVC is used, the joints must be cleaned with a suitable solvent and connected using a solvent based PVC cement. **The combustion air system MUST be supported by the building structure not the boiler/water heater.**

⚠CAUTION A combustion air damper interlocked with the unit should be installed in the intake air pipe when the infiltration of subfreezing air could occur, otherwise the unit could freeze up voiding the warranty!

Intake Air Option – Vertical Guidelines

The maximum equivalent length for the vertical intake air pipe is **60 ft, 18.3 m**. Each 90° elbow and the intake air terminal are equal to **10 linear ft, 3.1 m** of pipe.

An approved, nonrestrictive intake air terminal must be used. The intake air terminal must terminate as shown in Figure 5. The penetration point in the roof must be properly flashed and sealed.

FUTERA II INSTALLATION AND OPERATION INSTRUCTIONS

Intake Air Option – Horizontal Guidelines

The maximum equivalent length for the horizontal combustion air pipe on installations that used the Direct Vent option is **60 ft, 18.3 m**. The maximum equivalent length for the horizontal combustion air pipe on installations that use the Horizontal Power Vent option is **100 ft, 30.5 m**. Each 90° elbow and the combustion air terminal are equal to **10 linear ft, 3.1 m** of pipe. If horizontal runs exceed **5 ft, 1.5 m** they must be supported at **3 ft, 0.9 m** intervals with overhead hangers. The certified combustion air terminal from RBI must be used and installed as shown in Figures 3 and 4.

GENERAL VENTING GUIDELINES

WARNING The vent installation must be in accordance with Part 7, Venting of Equipment, of the National Fuel Gas Code, ANSI Z223.1/NFPA 54-latest revision or applicable provisions of the local building codes. Canadian installations must comply with CAN/CGA B149.1 or .2 Installation Code. See Figure A for added Clarity. Improper venting can result in excessive levels of carbon monoxide which can result in severe personal injury or death!

All vent systems must be fully supported by the building structure and not by the boiler/water heater. Appropriate thimbles and fire-stops must be used where required.

WARNING Common vent systems must be properly engineered and sized to provide a negative draft of 0.01 to 0.08 in, 0.25 to 2.0 mm W.C. at the flue outlet. Common positive pressure vent systems are not to be used. Improper installation can result in excessive levels of carbon monoxide, which can cause severe personal injury or death!

NOTICE Multi-story, common venting systems shall be in accordance with the National Fuel Gas Code, ANSI Z223.1/ NFPA 54 and/or the CSA B149.1, Natural Gas and Propane Installation Code (Current Editions), local codes and vent manufacturer's installation instructions. Size the chimney and breeching using generally accepted engineering practices. (Consult factory for vertical heights beyond 60 ft.)

NOTICE A single acting barometric damper must be installed directly to the boiler/water heater flue outlet, if required. This does not apply to outdoor units or direct vent positive pressure units.

NOTICE Some venting applications may require the stop to be removed for smooth operation. The barometric damper should be located after the flue collector, refer to Figures 2, 7A and 8 for proper location. Be sure that the damper is mounted horizontally (never vertically). Carefully follow the instructions provided with the barometric damper.

In Canada, B149 (7.25 Draft Regulators) states the damper shall be of double-acting type.

WARNING To avoid spillage into the room of dangerous flue gas containing carbon monoxide, the opening in damper must never face against the flow of flue gas.

WARNING Boiler/Water Heater shall not be connected to a chimney flue serving a separate appliance designed to burn solid fuel.

VENT SYSTEM OPTIONS

The Futera II may be vented the following ways:

- 1) **Direct Vent, Positive Pressure, Category III** uses a vent system certified to UL 1738 for installations in the United States, ULC S636 for installations in Canada. Combustion air is piped from the outdoors to the blower inlet.
- 2) **Side Wall Vent, Positive Pressure, Category III** uses a vent system certified to UL 1738 for installations in the United States, ULC S636 for installations in Canada. Combustion air is obtained from the space in which the unit is installed.
- 3) **Horizontal Vent, Negative Pressure, Category I** for horizontal vent runs equivalent to more than **60 ft, 18.3 m** (use Table 3 for the equivalent lengths per fitting), a dedicated wall mounted power venter must be used. The vent system can be single wall galvanized steel or type B vent pipe. Combustion air is obtained from the space in which the unit is installed or from the outdoors.

A power venter including a barometric damper must be installed when the horizontal run is longer than 60 equivalent feet (use Table 3 for the equivalent lengths per fitting).
- 4) **Vertical/Chimney Vent, Negative Pressure, Category I** uses an approved metal chimney system or masonry chimney. Combustion air is obtained from the space in which the unit is installed. A barometric damper must be installed near the flue outlet when venting vertically.
- 5) **Outdoor Installation** uses the outdoor option kit. Barometric damper is not required.

NOTICE All venting, combustion air material supplied by installer.

WARNING The maximum equivalent length for the flue outlet vent system for Category III conditions is 60 ft, 18.3 m. Use Table 3 for the equivalent lengths per fitting. Table 3 "Category III Equivalent Length Per Fitting" chart is meant as a guideline for preliminary sizing. If vent length approaches 75% of maximum length listed an engineered vent system calculation must be performed, consult factory.

FUTERA II INSTALLATION AND OPERATION INSTRUCTIONS

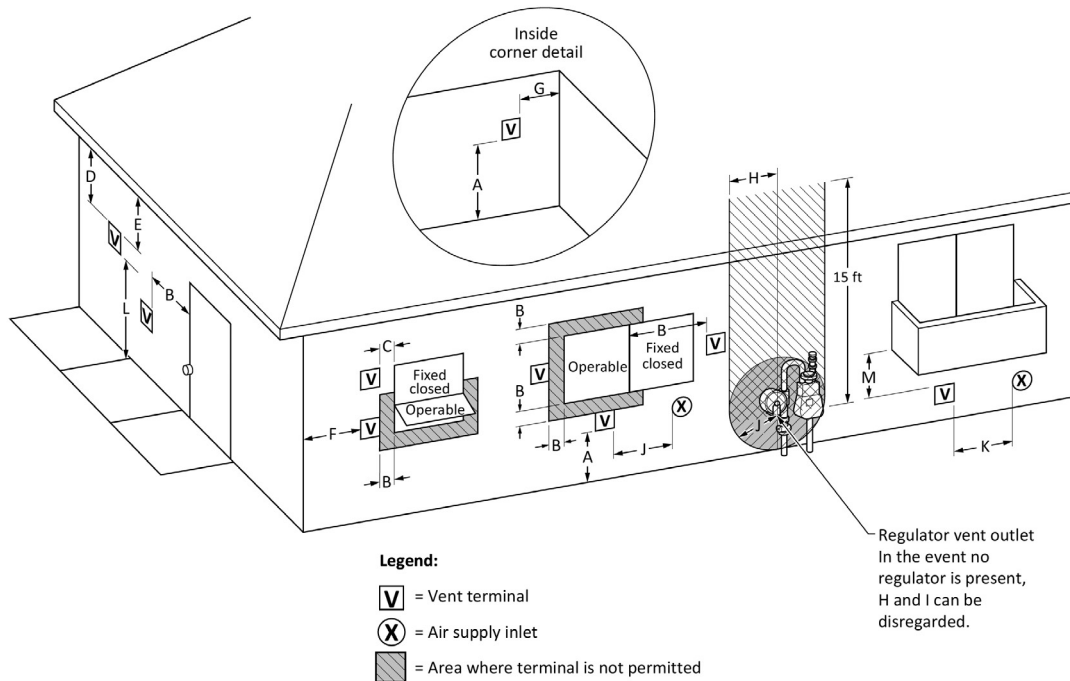

Figure A - Direct Vent Terminal Clearances

		Canadian Installations¹	US Installations²
A =	Clearance above grade, veranda, porch, deck, or balcony	12 in (30 cm)	12 in (30 cm)
B =	Clearance to window or door that may be opened	6 in (15 cm) for appliances ≤ 10,000 Btuh (3 kW); 12 in (30 cm) for appliances > 10,000 Btuh (3 kW) and ≤ 100,000 Btuh (30 kW); 36 in (91 cm) for appliances > 100,000 Btuh (30 kW)	6 in (15 cm) for appliances ≤ 10,000 Btuh (3 kW); 9 in (23 cm) for appliances > 10,000 Btuh (3 kW) and ≤ 50,000 Btuh (15 kW); 12 in (30 cm) for appliances > 50,000 Btuh (15 kW)
C =	Clearance to permanently closed window	Per local installation codes	
D =	Vertical clearance to ventilated soffit located above the terminal within a horizontal distance of 2 ft (61 cm) from the center line of the terminal.		
E =	Clearance to unventilated soffit		
F =	Clearance to outside corner		
G =	Clearance to inside corner		
H =	Clearance to each side of center line extended above meter / regulator assembly	3 ft (91 cm) within a height of 15 ft (4.6m)	
I =	Clearance to service regulator vent outlet	3 ft (91 cm)	
J =	Clearance to nonmechanical air supply inlet to building or the combustion air inlet to any other appliance	6 in (15 cm) for appliances ≤ 10,000 Btuh (3kW); 12 in (30 cm) for appliances > 10,000 Btuh (3 kW) and ≤ 100,000 Btuh (30 kW); 36 in (91 cm) for appliances > 100,000 Btuh (30 kW)	6 in (15 cm) for appliances ≤ 10,000 Btuh (3kW); 9 in (23 cm) for appliances > 10,000 Btuh (3 kW) and ≤ 50,000 Btuh (15 kW); 12 in (30 cm) for appliances > 50,000 Btuh (15 kW)

FUTERA II INSTALLATION AND OPERATION INSTRUCTIONS

Figure A - Direct Vent Terminal Clearances - Concluded

K =	Clearance to a mechanical air supply inlet	6 ft (1.83 m)	3 ft (91 cm) above if within 10 ft (3 m) horizontally
L =	Clearance above paved sidewalk or paved driveway located on public property	7 ft (2.13 m)†	7 ft (2.13 m) for mechanical draft systems (Category I appliances). Vents for Category II and IV appliances cannot be located above public walkways or other areas where condensate or vapor can cause a nuisance or hazard
M =	Clearance under veranda, porch, deck, or balcony	12 in (30 cm)‡	Per local installation codes
†	A vent shall not terminate directly above a sidewalk or paved driveway that is located between two single family dwellings and serves both dwellings.		
‡	Permitted only if veranda, porch, deck, or balcony is fully open on a minimum of two sides beneath the floor.		
NOTES:			
1)	In accordance with the current CSA B149.1, Natural Gas and Propane Installation Code		
2)	In accordance with the current ANSI Z223.1/NFPA 54, National Fuel Gas Code		
3)	If locally adopted installation codes specify clearances different than those illustrated, then the most stringent clearances must prevail.		

Figure A - Other Than Direct Vent Terminal Clearances

		Canadian Installations¹	US Installations²
A =	Clearance above grade, veranda, porch, deck, or balcony	12 in (30 cm)	12 in (30 cm)
B =	Clearance to window or door that may be opened	6 in (15 cm) for appliances ≤ 10,000 Btuh (3 kW); 12 in (30 cm) for appliances > 10,000 Btuh (3 kW) and ≤ 100,000 Btuh (30 kW); 36 in (91 cm) for appliances > 100,000 Btuh (30 kW)	4 ft (1.2 m) below or to side of opening; 1 ft (300 mm) above opening
C =	Clearance to permanently closed window	Per local installation codes	
D =	Vertical clearance to ventilated soffit located above the terminal within a horizontal distance of 2 ft (61 cm) from the center line of the terminal		
E =	Clearance to unventilated soffit		
F =	Clearance to outside corner		
G =	Clearance to inside corner		
H =	Clearance to each side of center line extended above meter/regulator assembly		
I =	Clearance to service regulator vent outlet	3 ft (91 cm)	
J =	Clearance to nonmechanical air supply inlet to building or the combustion air inlet to any other appliance	6 in (15 cm) for appliances ≤ 10,000 Btuh (3kW); 12 in (30 cm) for appliances > 10,000 Btuh (3 kW) and ≤ 100,000 Btuh (30 kW); 36 in (91 cm) for appliances > 100,000 Btuh (30 kW)	4 ft (1.2 m) below or to side of opening; 1 ft (300 mm) above opening

FUTERA II INSTALLATION AND OPERATION INSTRUCTIONS

Figure A - Other Than Direct Vent Terminal Clearances - Concluded

K =	Clearance to a mechanical air supply inlet	6 ft (1.83 m)	3 ft (91 cm) above if within 10 ft (3 m) horizontally
L =	Clearance above paved sidewalk or paved driveway located on public property	7 ft (2.13 m)†	7 ft (2.13 m) for mechanical draft systems (Category I appliances). Vents for Category II and IV appliances cannot be located above public walkways or other areas where condensate or vapor can cause a nuisance or hazard
M =	Clearance under veranda, porch, deck, or balcony	12 in (30 cm)‡	Per local installation codes

† A vent shall not terminate directly above a sidewalk or paved driveway that is located between two single family dwellings and serves both dwellings.
 ‡ Permitted only if veranda, porch, deck, or balcony is fully open on a minimum of two sides beneath the floor.

NOTES:

- 1) In accordance with the current CSA B149.1, Natural Gas and Propane Installation Code
- 2) In accordance with the current ANSI Z223.1/NFPA 54, National Fuel Gas Code
- 3) If locally adopted installation codes specify clearances different than those illustrated, then the most stringent clearances must prevail.

FUTERA II INSTALLATION AND OPERATION INSTRUCTIONS

Table 3 – Category III Equivalent Length Per Fitting

Model/Outlet	K	Equivalent Feet of Straight Pipe (ft) - Futera II Series							
		500 6"	750 8"	1000 9"	1250 10"	1500 10"	1750 12"	2000 12"	
Standard Tee	1.25	25 ft	35 ft	35 ft	40 ft	40 ft	40 ft	40 ft	
Boot Tee	0.65	15 ft	15 ft	15 ft	20 ft	20 ft	20 ft	20 ft	
Cap - Low Res (UL)	0.50	10 ft	15 ft	15 ft	15 ft	15 ft	15 ft	15 ft	
45° w/Bird Screen	0.40	10 ft	10 ft	10 ft	15 ft	15 ft	15 ft	15 ft	
Elbow - 90°	0.38	10 ft	10 ft	10 ft	15 ft	15 ft	15 ft	15 ft	
Elbow - 45°	0.15	5 ft	5 ft	5 ft	7 ft	7 ft	7 ft	7 ft	

*Equivalent lengths based on listed K-Factors

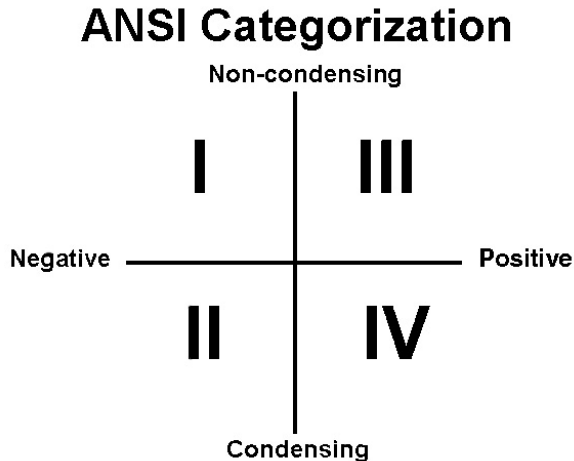

DIRECT VENT, POSITIVE PRÉSSURE, CATEGORY III

In this configuration the boiler/water heater blower is used to push the flue products to the outdoors while drawing combustion air from the outdoors. The equivalent length of the vent system must not exceed **60 ft., 18.3 m**. The Intake Air Option instructions under the “COMBUSTION AIR & VENTILATION” section must be followed! The vent system must be sized per Figure 2, Outlet Sizes.

Horizontal Direct Vent Systems – Figures 3 & 4

The vent materials used in horizontal vent systems must be certified to UL 1738 for installations in the United States, ULC S636 for installations in Canada. The certified vent terminal from RBI must also be used.

The maximum equivalent length for the horizontal vent pipe is **60 ft., 18.3 m**. If any part of a single wall metal vent system passes through an unheated space, it must be insulated with insulation rated for **400°F, 204°C**. Structural penetrations must be made using approved fire-stops. For best results, horizontal vent systems should be as short and straight as possible.

The vent system must be both gas tight and watertight. All seams and joints in metal pipes must be joined and sealed in accordance with the vent system manufacturer’s instructions.

When horizontal vent runs exceed **5 ft., 1.5 m** they must be supported at **3 ft., 0.9 m** intervals with overhead hangers. The vent system must be pitched down, toward the vent terminal, **1/4 in/ft., 20 mm/m**. If any part of a single wall metal vent system passes through an unheated space it must be insulated with insulation rated for **400°F, 204°C**.

Horizontal vent systems shall terminate at least **4 ft., 1.2 m** below, **4 ft., 1.2 m** horizontally from or **1 ft., 0.30 m** above any door, window or gravity air inlet into any building. It must not terminate less than **4 ft., 1.2 m** horizontally from, and in no case above or below, unless a **4 ft., 1.2 m** horizontal distance is maintained, from electric meters, gas meters, regulators and relief equipment and not less than **7 ft., 2.1 m** from any adjacent public walkway. Avoid terminal locations likely to be affected by winds, snowdrifts, people and pets. Protect building materials and vegetation from degradation caused by the flue gases.

Vertical Direct Vent Systems – Figure 5

The maximum equivalent length for the vertical pipe is **60 ft., 18.3 m**. If any part of a single wall metal vent system passes through an unheated space, it must be insulated with insulation rated for **400°F, 204°C**. Structural penetrations must be made using approved fire-stops.

An approved nonrestrictive intake air terminal must be used. The top of a vertical vent system must extend at least **5½ ft., 1.7 m** above the roof surface and maximum snow line that it passes through, **4 ft., 1.2 m** above the intake air terminal, see Figure 5.

In addition the vent system must conform to the dimensions shown in Figure 5. The penetration point in the roof must be properly flashed and sealed.

The vent system must be gas tight. All seams and joints in metal pipes must be joined and sealed in accordance with the vent system manufacturer’s instructions.

Combination Direct Vent Systems – Figure 6

The boiler/water heater can be vented vertically with the intake air piped horizontally through an outside wall. Follow the instructions in the Intake Air Option – Horizontal Guidelines on page 5. Also follow the general instructions in the “COMBUSTION AIR & VENTILATION” and “GENERAL VENTING GUIDELINES” sections.

FUTERA II INSTALLATION AND OPERATION INSTRUCTIONS

Figure 1 - Air Intake Vertical or Thru Wall

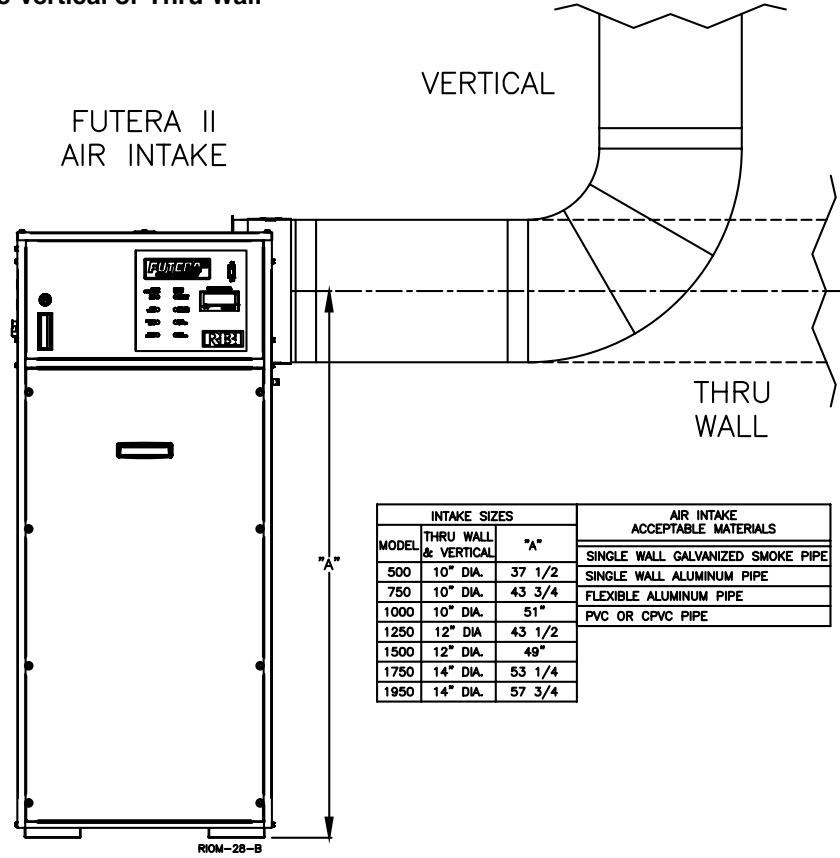
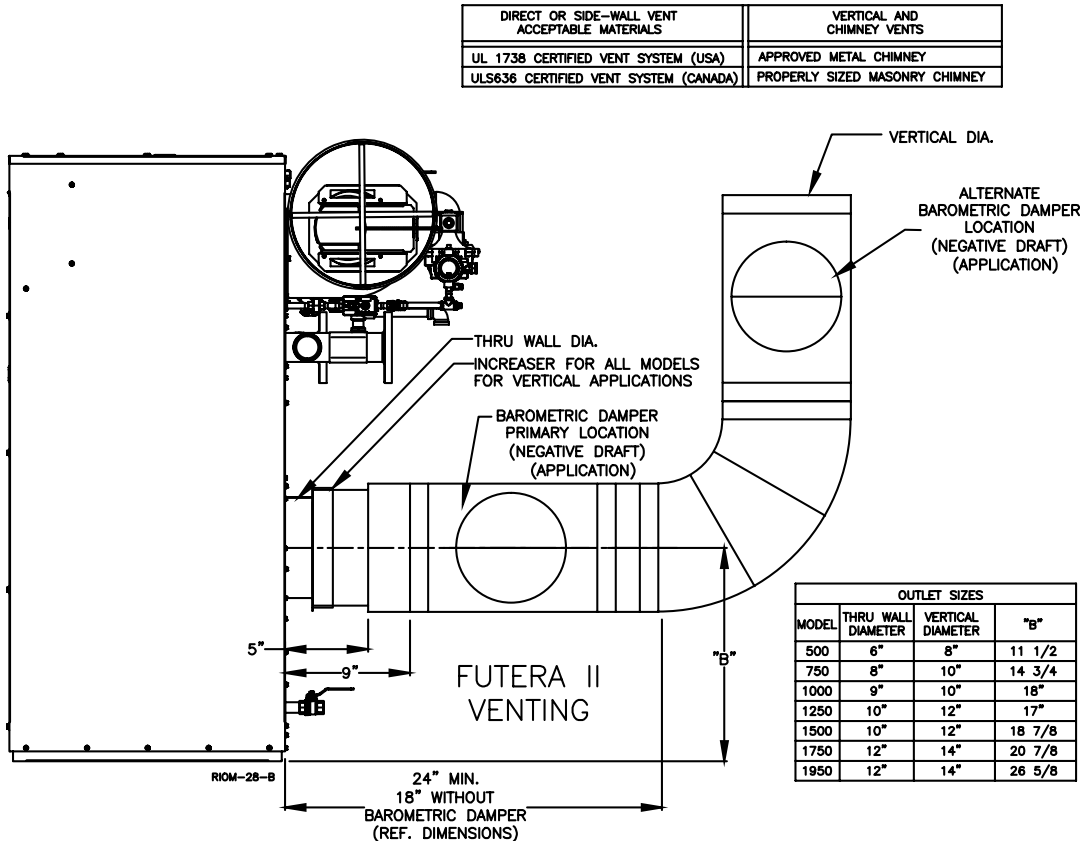
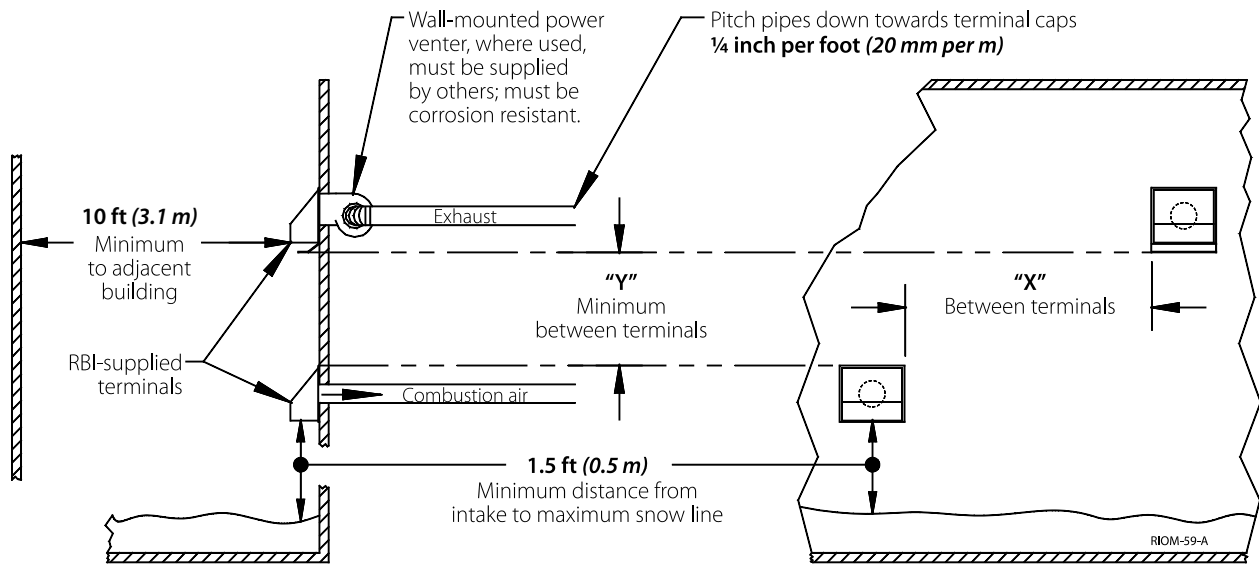

Figure 2 - Venting Thru Wall/Vertical



FUTERA II INSTALLATION AND OPERATION INSTRUCTIONS

Figure 3 – Horizontal Air Intake and Venting for a Single Direct Vent System



WARNING: When running horizontal combustion air and venting for single or multiple units, exhaust and combustion air terminals must be installed on the same plane (outside wall) in order to prevent pressure differences due to prevailing winds. In cold climates, double-wall or insulated inlet pipe recommended to prevent condensation.

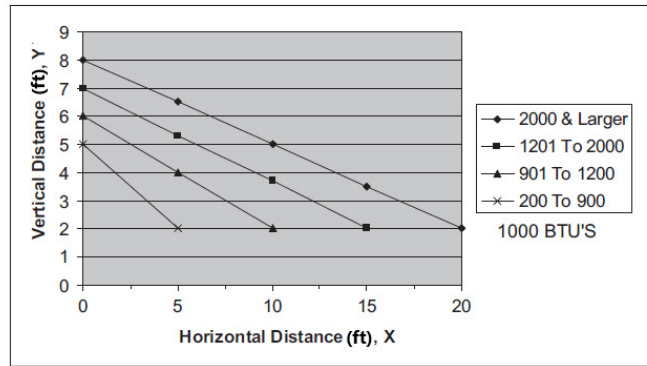
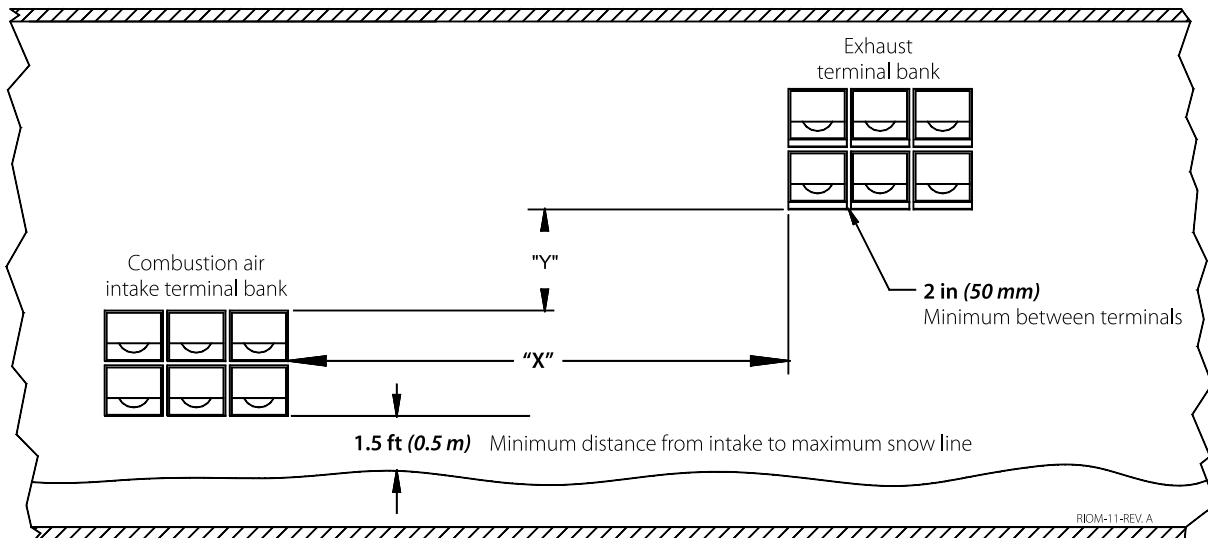

Figure 4 – Horizontal Air Intake and Venting for Multiple Direct Vent Systems



FUTERA II INSTALLATION AND OPERATION INSTRUCTIONS

Figure 5 - Vertical Air Intake and Venting for Direct Vent System

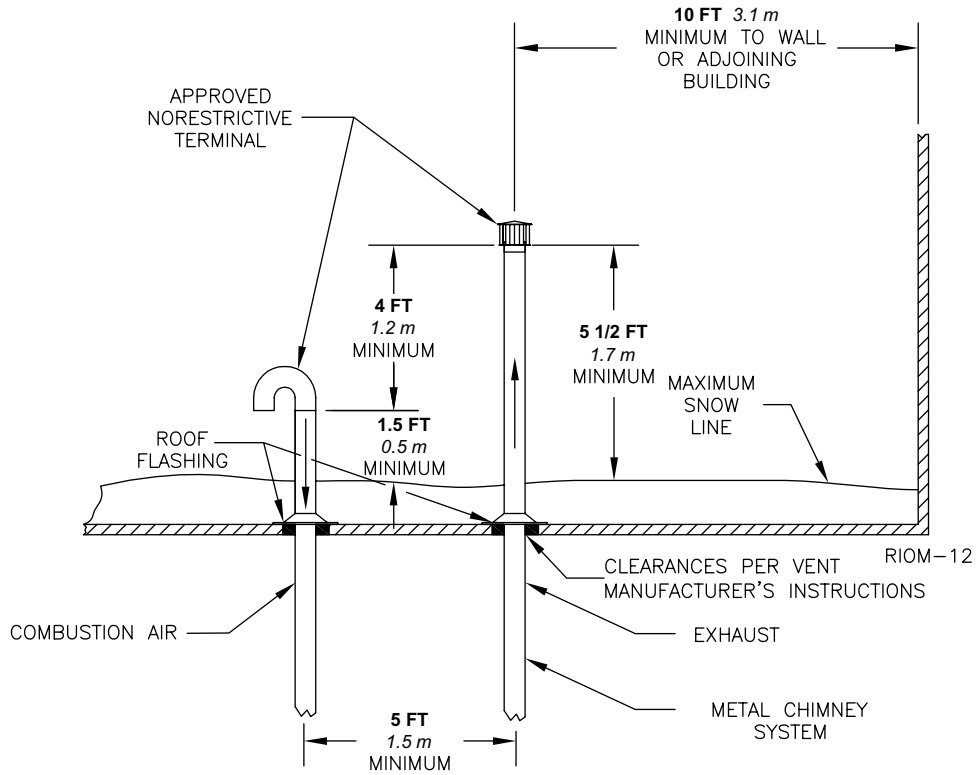
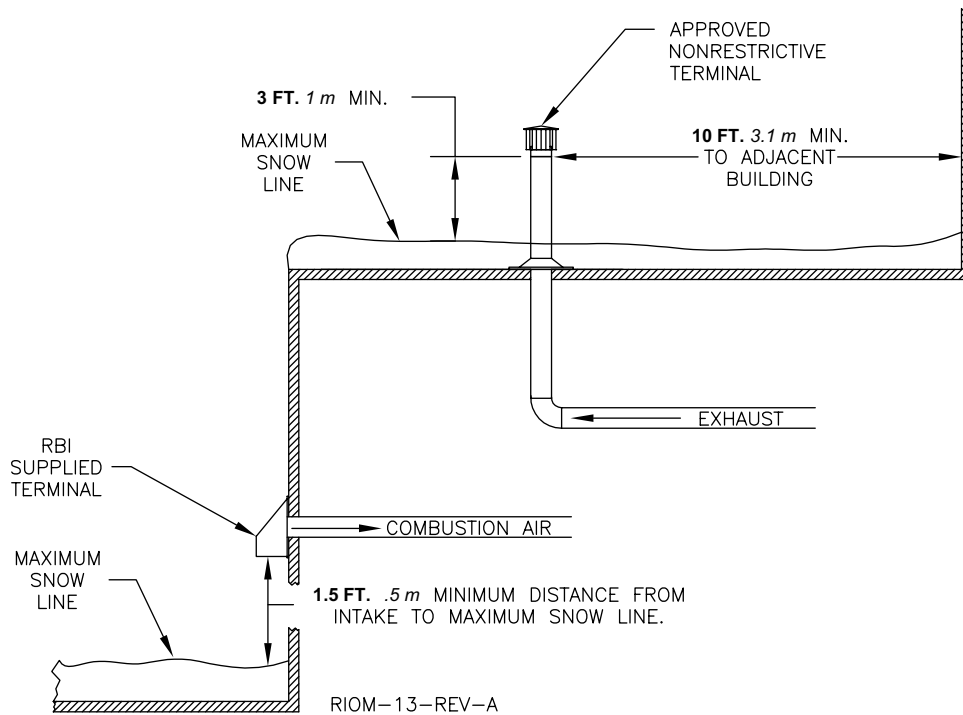

Figure 6 – Combination Direct Vent Systems



FUTERA II INSTALLATION AND OPERATION INSTRUCTIONS

SIDE WALL VENT, POSITIVE PRESSURE, CATEGORY III

In this configuration the boiler/water heater blower is used to push the flue products horizontally to the outdoors, see Figure 7. The air for combustion is taken from the space in which the unit is installed. The applicable instructions under the “COMBUSTION AIR & VENTILATION” section must be followed! The vent guidelines under the Horizontal Direct Vent Systems section must also be followed.

HORIZONTAL VENT, NEGATIVE PRESSURE, CATEGORY I

In this configuration a wall-mounted power venter must be used to pull the flue products horizontally from the unit and vent them to the outdoors, see Figures 3, 4 & 7A. The air for combustion is taken from the space in which the unit is installed, or from the outdoors. The applicable instructions under the “COMBUSTION AIR & VENTILATION” section must be followed!

To maximize the performance of single wall sheet metal vent systems locate 90° elbows as far from the boiler as possible and from one another. For best results, horizontal vent systems should be as short and straight as possible.

When horizontal vent runs exceed **5 ft, 1.5 m** they must be supported at **3 ft, 0.9 m** intervals with overhead hangers. The vent system must be pitched down, toward the vent terminal, **1/4 in/ft, 21 mm/m**. If any part of a single wall metal vent system passes through an unheated space it must be insulated with insulation rated for **400°F, 204°C**.

Horizontal vent systems shall terminate at least **4 ft, 1.2 m** below, **4 ft, 1.2 m** horizontally from or **1 ft, 0.30 m** above any door, window or gravity air inlet into any building. It must not terminate less than **4 ft, 1.2 m** horizontally from, and in no case above or below, unless a **4 ft, 1.2 m** horizontal distance is maintained, from electric meters, gas meters, regulators and relief equipment and not less than **7 ft, 2.1 m** from any adjacent public walkway. Avoid terminal locations likely to be affected by winds, snowdrifts, people and pets. Protect building materials and vegetation from degradation caused by the flue gases.

To determine the appropriate power venter for the boiler/water heater, see Table 4. Follow the power venter manufacturer’s installation instructions.

Table 4 - Power Venter Sizes

Futera II Model	Power Venter Model	Max. Pipe Length	
		FT	m
500 - 750	HS-3	100	31
1000-1250	HS-4	100	31
1500-1950	HS-5	100	31

VERTICAL/CHIMNEY VENT, NEGATIVE PRESSURE, CATEGORY I

The Futera II is listed as a Category I appliance when vented vertically into a listed metal chimney system or properly sized masonry chimney, Figures 8 & 9. The chimney must provide a **negative** pressure of **0.01 to 0.08 in, 0.25 to 2.0 mm WC** at the boiler/water heater flue collar with the unit running. A barometric damper must be attached directly to the flue collar increaser as shown.

Multiple Futera II’s can be vented into a single vertical chimney provided that the breeching and chimney are properly sized per the latest revision of the National Fuel Gas Code, ANSI Z223.1.

When more than one appliance is connected to the same chimney flue, the flue must be large enough to safely vent the combined output of all of the appliances.

⚠WARNING If an appliance using any type of a mechanical draft system operating under positive pressure is connected to a chimney flue, never connect any other appliances to this flue. Doing so can result in excessive levels of carbon monoxide which can cause severe personal injury or death!

Chimney Inspection & Sizing

A thorough inspection of the masonry chimney must be performed to ensure that the chimney is clean, properly constructed and properly sized. Exterior masonry chimneys should not be used unless properly lined to prevent condensation and draft problems. Table 5 lists the minimum riser connection diameters, negative pressure required for the boiler/water heater.

Table 5 - Minimum Riser Connection, Negative Pressure

Model Size	Pipe Diameter	
	in	mm
500	8	203
750, 1000	10	254
1250, 1500	12	305
1750, 1950	14	356

Note: Vent system must be sized per tables contained in NFPA 54 or an engineered system.

Vent Connections

Locate the boiler/water heater as close to the chimney as possible. Use the shortest, straightest vent connector possible for the installation. If horizontal runs exceed **5 ft, 1.5 m** they must be supported at **3 ft, 0.9 m** intervals with overhead hangers. Use a type B, single wall stainless or single wall galvanized steel vent pipe the same diameter as the flue collar to connect the boiler/water heater to a masonry chimney, see Figure 2. When using a listed metal chimney system use the appropriate vent connector.

FUTERA II INSTALLATION AND OPERATION INSTRUCTIONS

The vent connector should be sloped up toward the chimney at a minimum rate of $1/4$ in/ft, 21 mm/m. On masonry chimneys the connector must terminate flush with the inside of the chimney flue, Figure 9. Fasten each single wall vent connection with at least 3 corrosion resistant sheet metal screws.

⚠ WARNING Failure to maintain minimum clearances between vent connectors and any combustible material can result in a fire causing extensive property damage, severe personal injury or death!

Always provide a minimum clearance of **6 in, 152 mm** between single wall vent pipe and any combustible materials. Type B1 vent may be used, clearance between it and any combustible material must be as listed.

Figure 7 – Side Wall Venting, Positive Pressure

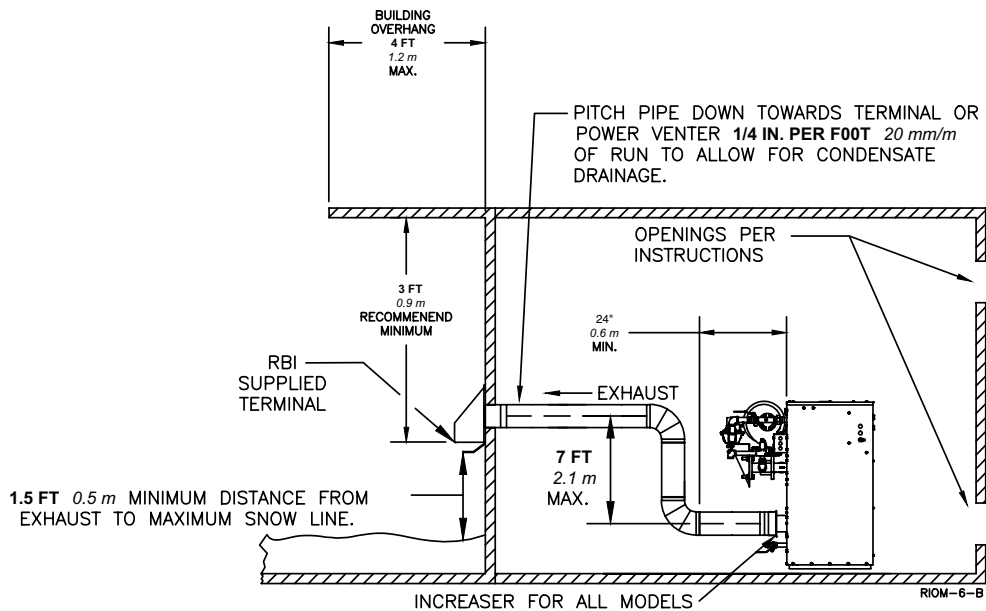
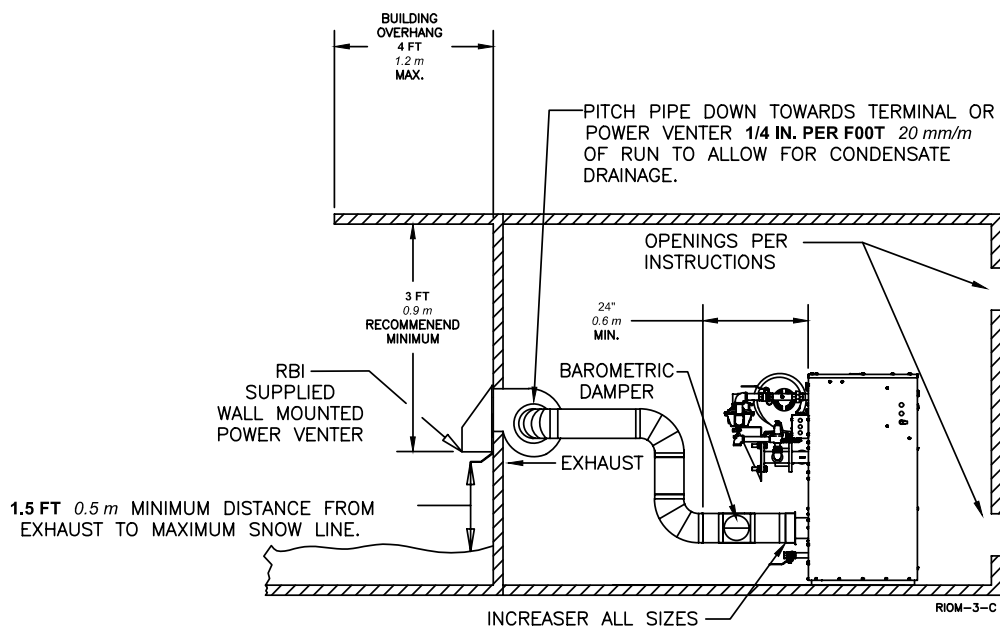
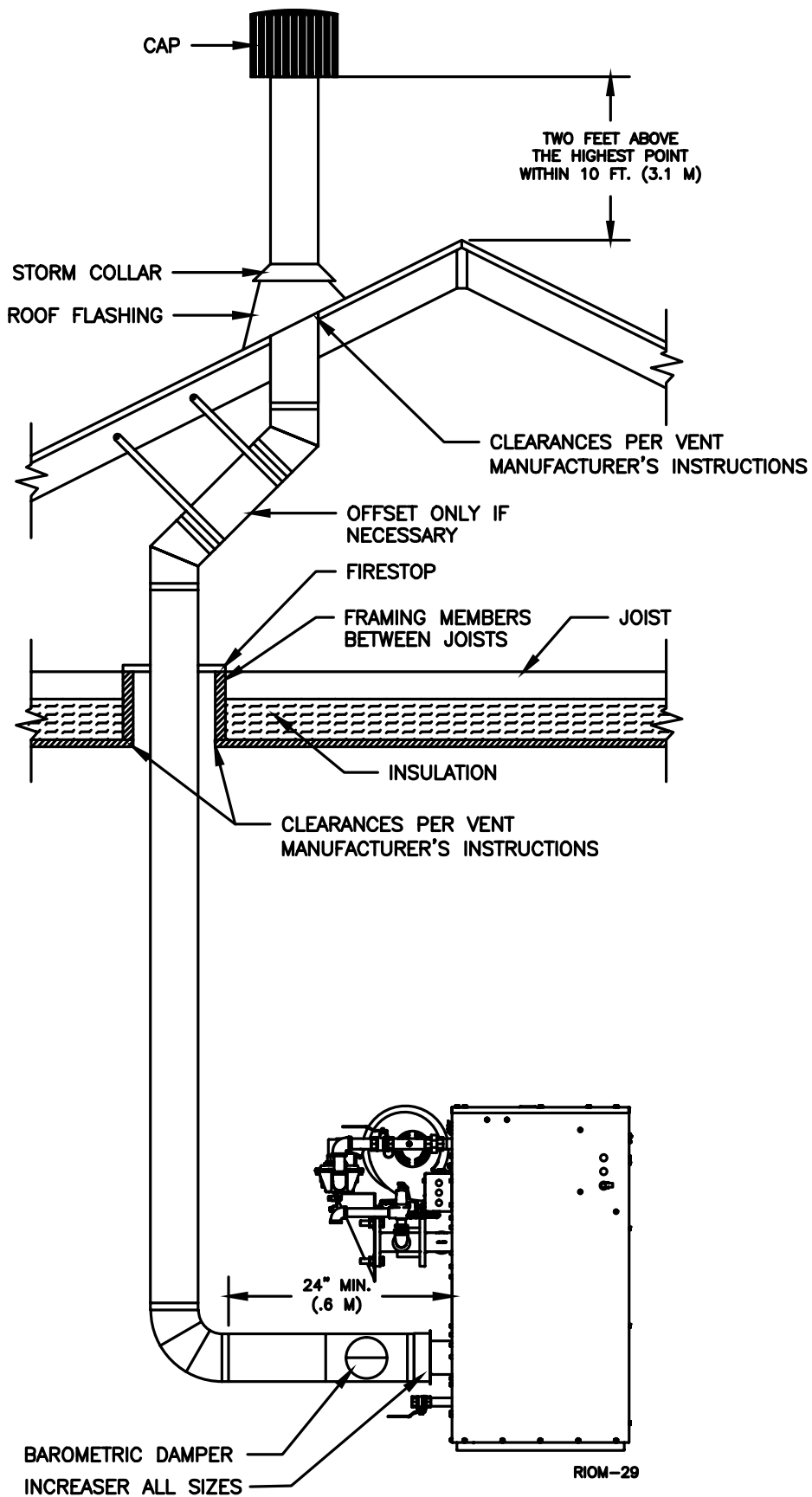

Figure 7A – Power Venting, Negative Pressure



FUTERA II INSTALLATION AND OPERATION INSTRUCTIONS

Figure 8 – Vertical Venting with a Metal Chimney System



FUTERA II INSTALLATION AND OPERATION INSTRUCTIONS

Figure 9 – Vertical Venting using a Masonry Chimney

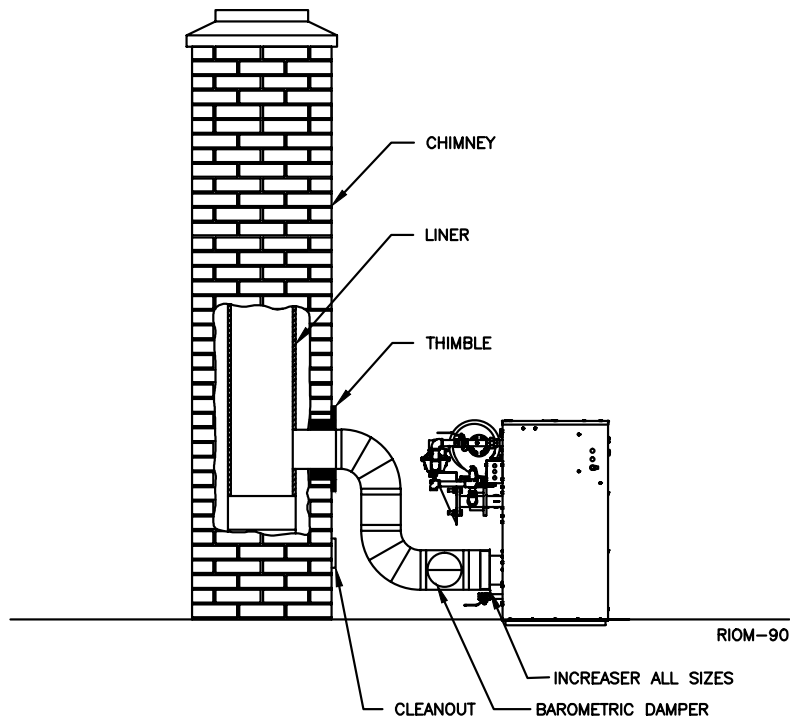

OUTDOOR VENTING

When installed outdoors the Futera III must be fitted with the factory supplied outdoor hood, air intake adapter with filter and exhaust terminal, see Figure 7A. Multiple units must be spaced per Figure 7B.

The boiler/heater must be at least **2 ft, .62 m** from any door, window or gravity air inlet into any building and at least **3 ft, 1 m** from any overhang unless local codes dictate differently.

Avoid locations where wind deflection off of adjacent walls, buildings or shrubbery might cause a downdraft. The unit(s) should be located at least **3 ft, 1 m** from structures. Outdoor installations are not recommended in areas where the danger of snow blockage exists.

CAUTION Do not place the boiler/water heater in a location that would subject it to runoff from adjacent buildings or damage may occur voiding the warranty!

Figure 10 – Outdoor Venting

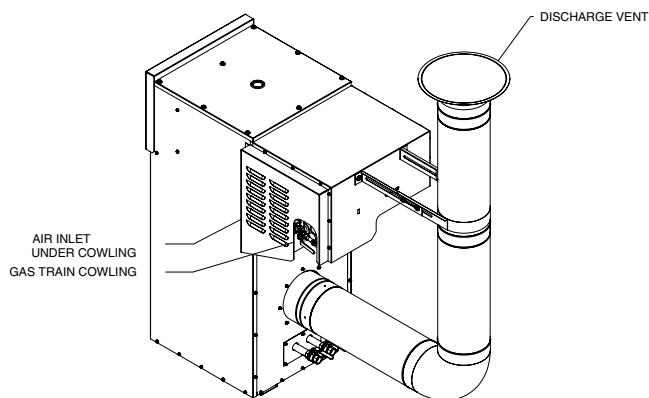
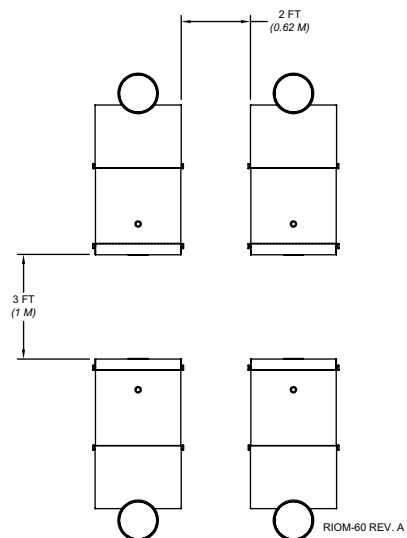

Figure 11 – Multiple Outdoor Units



FUTERA II INSTALLATION AND OPERATION INSTRUCTIONS

COMMON VENT SYSTEMS

If an existing boiler/water heater is removed from a common venting system, the common venting system may then be too large for the proper venting of the remaining appliances connected to it. At the time of removal of an existing boiler/water heater, the following steps shall be followed with each appliance remaining connected to the common venting system placed in operation, while the other appliances remaining connected to the common venting system are not in operation.

- a) Seal any unused openings in the common venting system.
- b) Visually inspect the venting system for proper size and horizontal pitch and determine there is no blockage or restriction, leakage, corrosion and other deficiencies which could cause an unsafe condition.
- c) Insofar as is practical, close all building doors and windows and all doors between the space in which the appliances remaining connected to the common venting system are located and other spaces of the building. Turn on clothes dryers and any appliance not connected to the common venting system. Turn on any exhaust fans, such as range hoods and bathroom exhaust, so they will operate at maximum speed. Do not operate a summer exhaust fan for a boiler installation. Close fireplace dampers.
- d) Place in operation the appliance being inspected. Follow the lighting instructions. Adjust thermostat so appliance will operate continuously.
- e) Test for spillage at the draft hood relief opening after 5 minutes of main burner operation. Use the flame of a match or candle, or smoke from a cigarette, cigar or pipe.
- h) After it has been determined that each appliance remaining connected to the common venting system properly vents when tested as outlined above, return doors, windows, exhaust fans, fireplace dampers and any other gas-burning appliance to their previous condition of use.
- g) Any improper operation of the common venting system should be corrected so the installation conforms with the National Fuel Gas Code, ANSI Z223.1/NFPA 54. When resizing any portion of the common venting system, the common venting system should be resized to approach the minimum size as determined using the appropriate tables in Appendix F in the National Fuel Gas Code, ANSI Z223.1/ NFPA 54 and or CAN/CGA B149 Installation Codes.

GENERAL PIPING REQUIREMENTS

CAUTION Improper piping of this boiler/water heater will void the manufacturer's warranty and can cause boiler failure resulting in flooding and extensive property damage! Excessive water hardness causing scaling in the copper heat exchanger tubes is NOT covered under the manufacturer's warranty. Excessive pitting and erosion of the internal surface of the copper heat exchanger tubes is NOT covered under the manufacturer's warranty if the result of high water flow rates, see Table 5. Return water temperatures below 125°F, 52°C will result in heat exchanger damage from excessive condensation voiding the manufacturer's warranty, see Primary /Secondary Piping, Figure 13.

NOTICE Shut off valves and unions should be installed at the inlet and outlet connections of the boiler/hot water heater to provide for isolation of the unit should servicing be necessary.

Freeze Protection

This boiler/water heater is CSA designed certified for outdoor installation. Outdoor installations in areas where the danger of freezing exists are not recommended unless proper freeze protection is provided. The following precautions MUST be observed:

1. A continuous flow of water through the unit MUST be maintained! The pump responsible for flow through the boiler/water heater must run continuously!
2. A propylene glycol/water mixture suitable for the minimum temperature that the unit will be exposed to must be used. The pump must be capable of producing a minimum of 15% more flow and overcoming a 20% increase in head loss. Domestic water systems must be isolated from the water heater by the use of a heat exchanger or other approved method.
3. If the unit must be shut off for any reason the electric, gas and water supplies MUST be shut off and the unit and its pump completely drained.

CAUTION Improper outdoor installation of this unit can cause boiler failure voiding the manufacturer's warranty!

For systems requiring glycol for freeze protection use a glycol/water mix that prevents foaming. Air entrapped within foam significantly decreases heat transfer and can result in damage to the heat exchanger. Products such as DOWFROST, DOWTHERM, UCARTHERM or an equivalent product must be used to ensure proper protection to the boiler.

The water used for dilution of concentrated heat transfer fluids must be distilled, de-ionized, or equivalently clean as stated above. De-ionized water by itself can be aggressive towards many metals, but is perfectly safe when used for dilution of DOWFROST, DOWTHERM or UCARTHERM as specified by the manufacturer.

FUTERA II INSTALLATION AND OPERATION INSTRUCTIONS

Relief Valve

Pipe the discharge of the pressure relief valve as shown in Figure 12.

WARNING Never install any type of valve between the boiler/water heater and the relief valve or an explosion causing extensive property damage, severe personal injury or death may occur!

Flow Switch

The flow switch is provided to prove flow is present through the boiler. The temperature rise across the primary heat exchanger must never exceed 35°F, 19.4°C.

CAUTION Failure to properly install the flow switch may result in damage to the boiler/water heater heat exchanger voiding the warranty!

Figure 12 – Futera II Piping

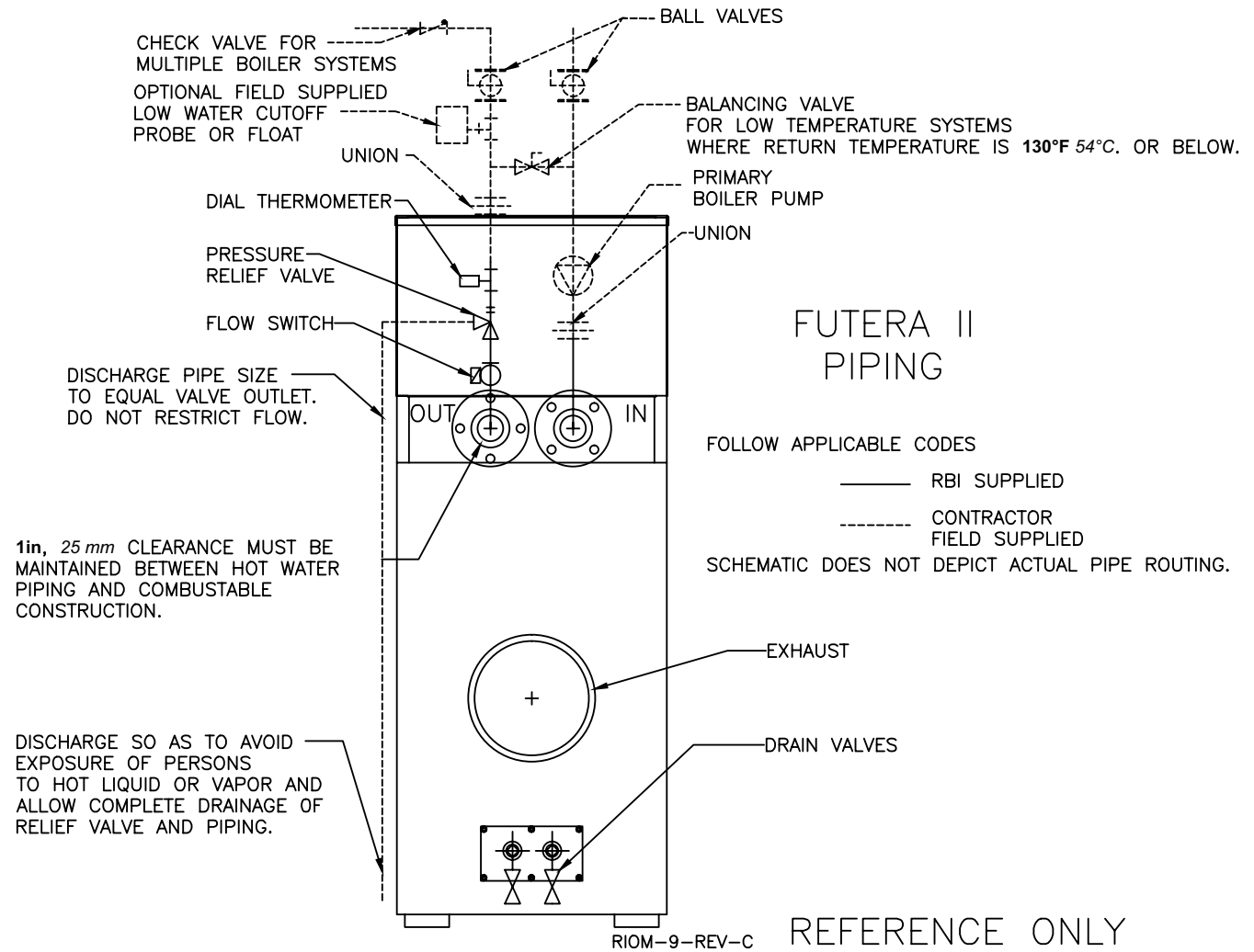

FUTERA II INSTALLATION AND OPERATION INSTRUCTIONS

HEATING SYSTEM PIPING

General Piping Requirements

All heating system piping must be installed by a qualified technician in accordance with the latest revision of the ANSI/ASME Boiler and Pressure Vessel Code, Section IV, and ANSI/ASME CSD-1, Standard for Controls and Safety Devices for Automatically Fired Boilers. All applicable local codes and ordinances must also be followed. A minimum clearance of **1 in, 25 mm** must be maintained between heating system pipes and all combustible construction. All heating system piping must be supported by suitable hangers not the boiler. The thermal expansion of the system must be considered when supporting the system. A minimum system pressure of **12 psig, 82.7 kPa** must be maintained.

Heating Boiler Piping Connections

The supply and return connections should be sized to suit the system, see Table 6.

Table 6 – Supply & Return Pipe Sizing

Model Size	Supply Size	Return Size
500 thru 1000	2" NPT	2" NPT
1250 thru 1950	2 1/2" NPT	2 1/2" NPT

Pump Requirements

This low mass boiler requires a continuous minimum water flow for proper operation. The system pump must be sized to overcome the head loss of the boiler and the heating system in order to achieve the required temperature rise. Table 7 provides the heat exchanger pressure drop and temperature rise figures. The temperature rise across the boiler must never exceed **35°F, 19.4°C**. The adjustable pump delay turns the pump on each time the burner fires and runs the pump for 6 to 600 seconds after the call for heat is satisfied.

CAUTION A temperature rise outside of the range listed in Table 7 indicates that the flow rate through the heat exchanger is incorrect which will damage the heat exchanger voiding the warranty! The maximum allowable temperature rise is 35°F, 19.4°C.

The maximum allowable flow rate through a Futera II boiler is 97 GPM, 6.1 L/s on 500 through 1000 models and 136 GPM, 8.6 L/s for 1250 through 1950 models. The Cupro-Nickel heat exchanger allows for 108 GPM, 6.8 L/s on 500 through 1000 models and 151 GPM, 9.5 L/s on 1250 through 1950 models.

Table 7 - Temperature Rise

		$\Delta T = 20^{\circ}\text{F}$		$\Delta T = 11.1^{\circ}\text{C}$	
Model Number	Flow Rate GPM	Pres. Drop Ft	Flow Rate L/s	Pres. Drop kPa	
500	42.5	0.53	2.7	1.5	
750	63.8	1.57	4.0	4.6	
1000	85.0	3.44	5.4	10.1	
1250	106.3	2.11	6.7	6.2	
1500	127.5	3.57	8.0	10.5	
		$\Delta T = 25^{\circ}\text{F}$		$\Delta T = 13.9^{\circ}\text{C}$	
Model Number	Flow Rate GPM	Pres. Drop Ft	Flow Rate L/s	Pres. Drop kPa	
500	34.0	0.35	2.1	1.0	
750	51.0	1.04	3.2	3.1	
1000	68.0	2.27	4.3	6.7	
1250	85.0	1.40	5.4	4.1	
1500	102.0	2.36	6.4	7.0	
1750	119.0	3.67	7.5	10.8	
1950	132.6	5.14	8.4	15.1	
		$\Delta T = 30^{\circ}\text{F}$		$\Delta T = 16.7^{\circ}\text{C}$	
Model Number	Flow Rate GPM	Pres. Drop Ft	Flow Rate L/s	Pres. Drop kPa	
750	42.5	0.70	2.7	2.2	
1000	56.7	1.60	3.6	4.8	
1250	70.8	1.00	4.5	2.9	
1500	85.0	1.70	5.4	5.0	
1750	99.2	2.60	6.3	7.7	
1950	110.5	3.70	7.0	10.8	
		$\Delta T = 35^{\circ}\text{F}$		$\Delta T = 19.4^{\circ}\text{C}$	
Model Number	Flow Rate GPM	Pres. Drop Ft	Flow Rate L/s	Pres. Drop kPa	
750	36.4	0.60	2.3	1.6	
1000	48.6	1.20	3.1	3.6	
1250	60.7	0.70	3.8	2.2	
1500	72.9	1.30	4.6	3.7	
1750	85.0	2.00	5.4	5.8	
1950	94.7	2.80	6.0	8.1	

FUTERA II INSTALLATION AND OPERATION INSTRUCTIONS

Low Water Cutoff

If a boiler is installed above any radiation elements it must be fitted with a low water cutoff device.

Refer to the wiring diagram supplied with the boiler/water heater for proper wiring connections.

Expansion Tank & Air Separator

An expansion tank or other means to control thermal expansion must be installed in the heating system. An expansion tank must be installed close to the boiler on the suction side of the pump. An air scoop and automatic air vent must also be installed to eliminate air trapped in the system.

Primary/Secondary Piping

Boilers connected to heating systems using zone valves, zone pumps, or systems that have excessive flow rates or return water temperatures less than **125°F, 52°C** must be isolated from these systems to protect the boiler. Figure 13, shows a typical primary/secondary piping system. A dedicated pump is used to maintain a constant water flow through the boiler. This boiler pump is sized to overcome the head loss of the boiler and near-boiler piping system while supplying the flow rate required to maintain the desired temperature rise across the boiler heat exchanger. The system pump is sized to provide the required flow to the heating system. The boiler piping connections to the heating system piping must be a maximum 10X pipe diameters between centers to ensure zero pressure drop in the primary system. Flow must be properly accounted for in the design of primary/secondary systems. In order to prevent boiler(s) short cycling the system flow must be equal to or higher than the boiler(s) local flow.

Low Return Water Temperatures

To prevent the problems associated with condensation of the products of combustion due to low return water temperatures a primary/secondary piping system with a bypass and bypass valve must be installed, see Figure 14 and 14A. The bypass and bypass valve must be sized the same as the secondary piping. A balancing valve must also be installed in the supply side of the secondary piping downstream of the bypass. The balancing valve should be adjusted to divert some of the heated discharge water into the return water until the required inlet water temperature is achieved. The primary and secondary pumps should be sized to provide the required flow through each system. The secondary piping connections to the primary system piping must not be more than 10X pipe diameters apart to ensure zero pressure drop in the primary system, see Figure 14.

Multiple Boiler Systems

Systems using multiple boilers can also be installed using a primary/secondary manifold system, Figure 15.

Piping For Use With Cooling Units

The boiler, when used in connection with a refrigeration system, must be installed so the chilled medium is piped in parallel with the boiler. Appropriate valves must be used to prevent the chilled water from entering the boiler.

When a boiler is connected to a heating coil that may be exposed to refrigerated air from an air handling device, the piping system must be equipped with flow-control valves or some other automatic means of preventing gravity circulation of the boiler water during the cooling cycle.

FUTERA II INSTALLATION AND OPERATION INSTRUCTIONS

Figure 13 - Typical Boiler Primary/Secondary Piping System
(See Notes)

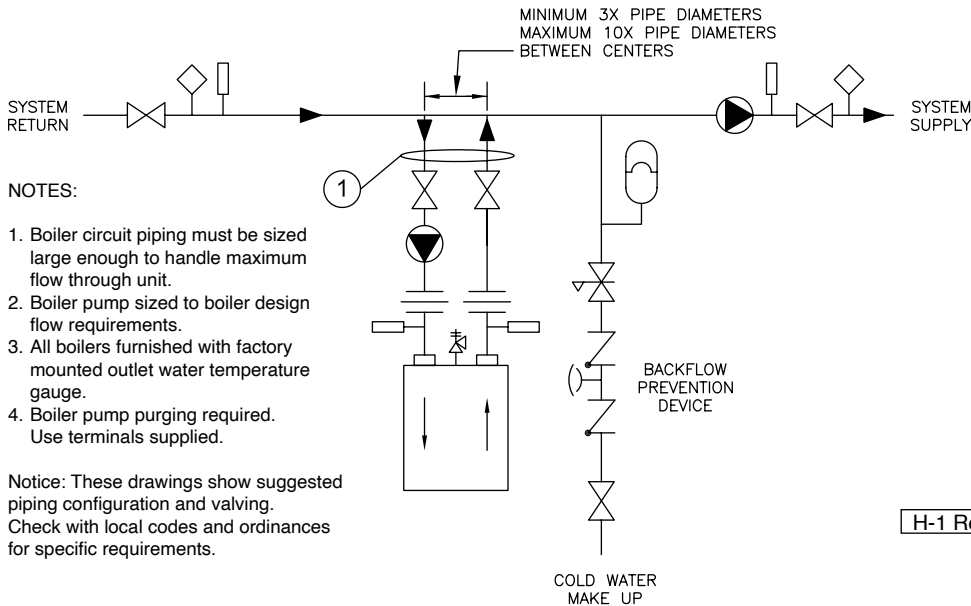

NOTES:

1. Boiler circuit piping must be sized large enough to handle maximum flow through unit.
2. Boiler pump sized to boiler design flow requirements.
3. All boilers furnished with factory mounted outlet water temperature gauge.
4. Boiler pump purging required. Use terminals supplied.

Notice: These drawings show suggested piping configuration and valving. Check with local codes and ordinances for specific requirements.

Figure 14 - Low Temperature Piping with Thermostatic Valve
(See Notes)

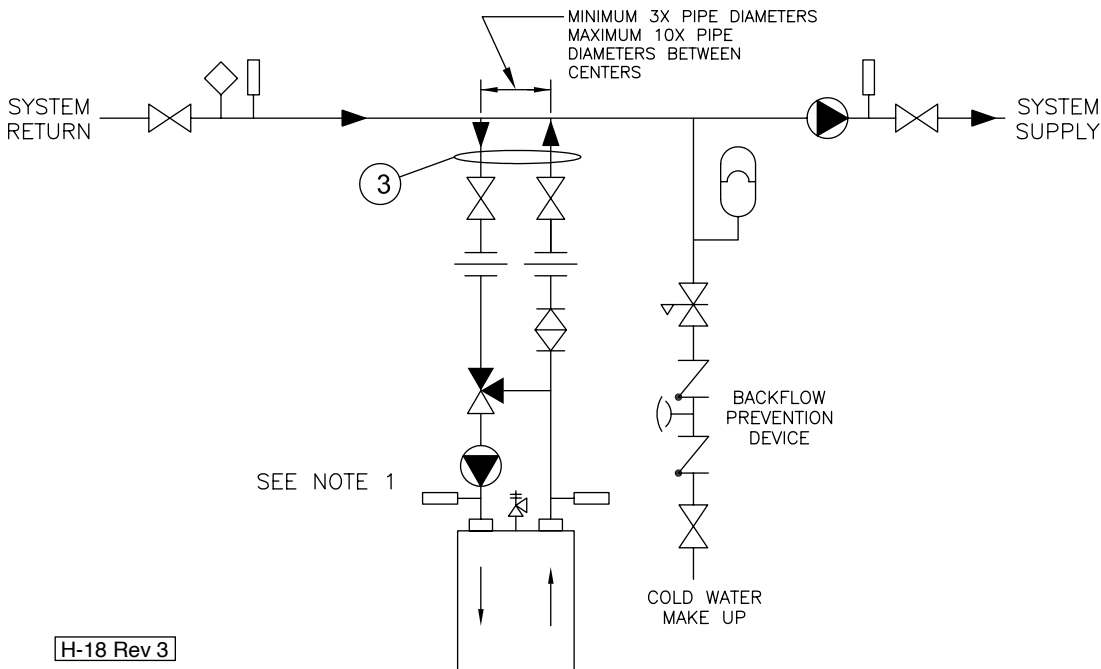

NOTES:

1. For pump selection consult factory.
2. Boiler pump sized to boiler and thermostatic 3-way valve design flow requirements.
3. Boiler circuit piping must be sized large enough to handle maximum flow through unit.
4. All boilers furnished with factory mounted outlet water temperature gauge.
5. Boiler pump purging required. Use terminals supplied.
6. Valve is precalibrated for 140°F return temperature.

Notice: These drawings show suggested piping configuration and valving. Check with local codes and ordinances for specific requirements.

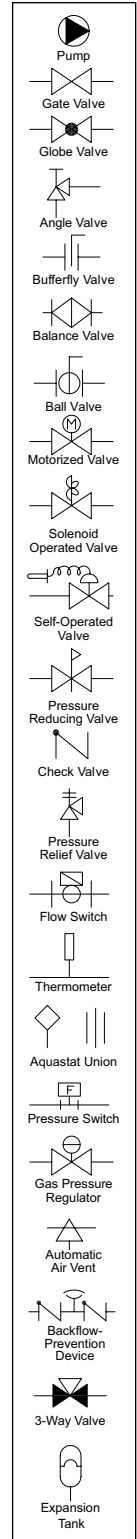

FUTERA II INSTALLATION AND OPERATION INSTRUCTIONS

Figure 14A - Low Temperature Boiler Piping
(See Notes and Adjustment Procedures)

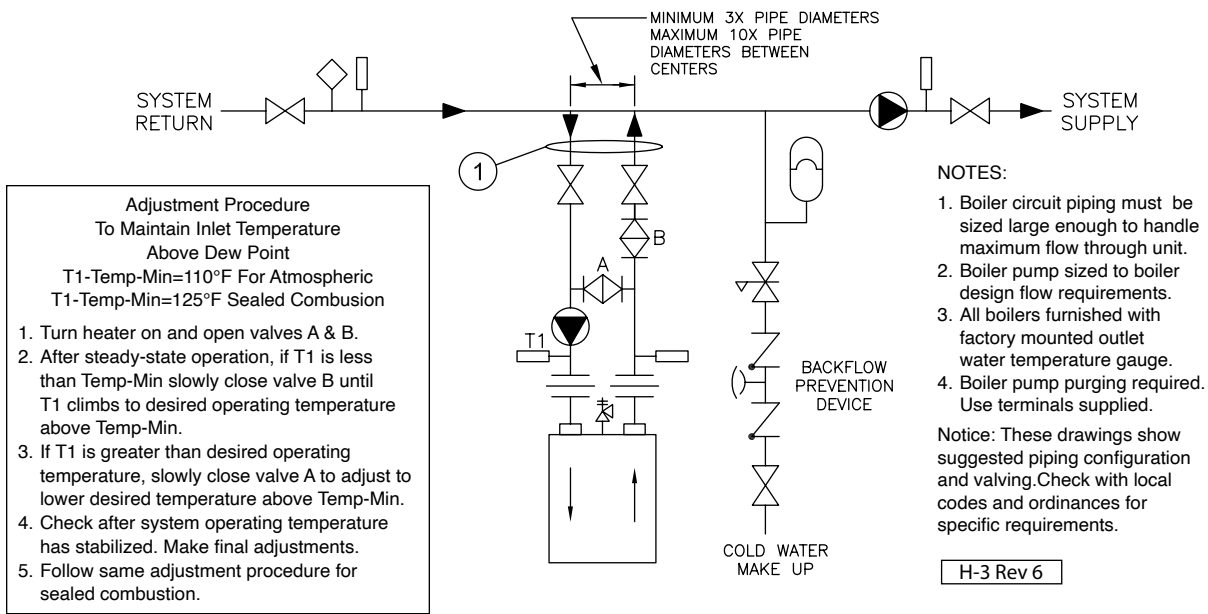
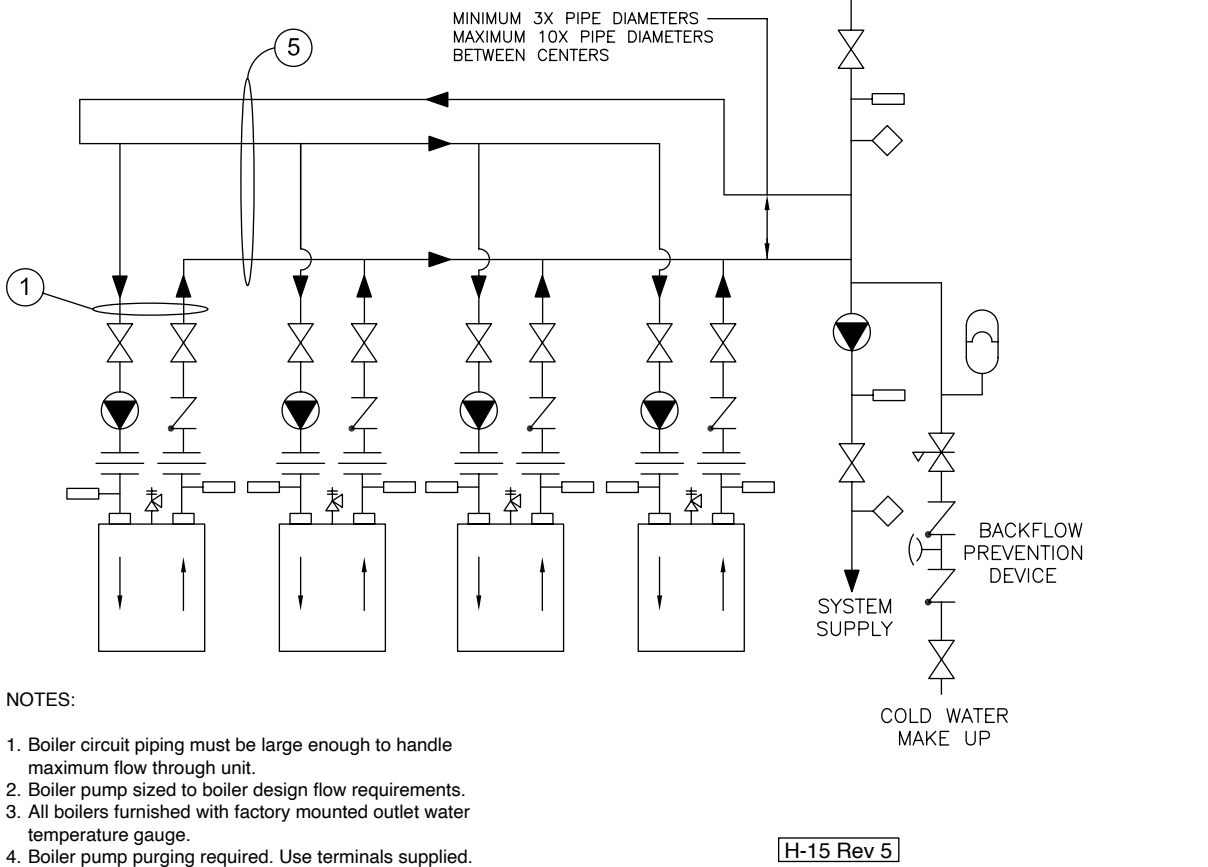

Figure 15 - Multiple Boiler Piping
(See Notes and Adjustment Procedures)



	Pump
	Gate Valve
	Globe Valve
	Angle Valve
	Butterfly Valve
	Balance Valve
	Ball Valve
	Motorized Valve
	Solenoid Operated Valve
	Self-Operated Valve
	Pressure Reducing Valve
	Check Valve
	Pressure Relief Valve
	Flow Switch
	Thermometer
	Aquistat Union
	Pressure Switch
	Gas Pressure Regulator
	Automatic Air Vent
	Backflow-Prevention Device
	Expansion Tank

FUTERA II INSTALLATION AND OPERATION INSTRUCTIONS

DOMESTIC WATER SUPPLY PIPING

CAUTION Proper controls must be used to prevent water supplied for domestic use from exceeding 130°F, 54°C or a scald injury will occur! When higher water temperatures are required for appliances such as a dishwasher, a mixing valve or some other tempering means must be installed. Households with small children may require water temperatures less than 120°F, 49°C. Local codes must be complied with!

General Piping Requirements

Ensure that the water heater is equipped with bronze headers. Piping and components connected to the water heater must be suitable for use with potable water. The water heater must not be connected to any heating system piping or components previously used with a non-potable water heating appliance. No toxic chemicals, such as those used for boiler treatment, are to be introduced into the potable water used for space heating. If a hot water storage tank is used in the system it must be equipped with a temperature and pressure relief valve that complies with ANSI Z21.22 or CAN-4.4 and CAN-4.6.

NOTICE The storage tank must be located as close to the water heater as possible to prevent excessive head loss which will reduce flow.

Water Chemistry

The required temperature rise across the water heater is based on water having a hardness between 8 and 18 grains per gallon with a level of dissolved solids not exceeding 350 ppm. Water having a hardness less than 8 grains can cause excessive corrosion of the heat exchanger. Water that has a hardness greater than 18 grains per gallon and/or a level of dissolved solids exceeding 350 ppm will require a recalculation of the pump size and temperature rise.

A cupro-nickel heat exchanger may also be required. The manufacturer should be consulted when these water conditions are encountered. See Table 8.

CAUTION The maximum allowable flow rate through a Futera II water heater is 97 GPM, 6.1 L/s on 500 through 1000 models and 136 GPM, 8.6 L/s for 1250 through 1950 models. The Cupro-Nickel heat exchanger allows for 108 GPM, 6.8 L/s on 500 through 1000 models and 151 GPM, 9.5 L/s on 1250 through 1950 models. See Table 9.

RBI water heaters are designed to run scale free. Due to the extreme variables of water conditions world wide it is necessary to consider pH values and water hardness in relationship to scaling. It is crucial to consider these two variables when making heat exchanger and pump selection. If local water conditions are extreme, follow the guidelines in the Heat Exchanger Selection Table (Table 8) and the Pumping Performance Table (Table 9). Scale free operation can be achieved by using water with a hardness between 8 and 18 and by maintaining the pH between 5 and 9. Follow the conditions listed under NORMAL in the table. In some areas of the country additional precautions must be observed due to unusual characteristics of the local water supply. Call the nearest RBI representative for details.

To properly size the pump a grain hardness and pH test must be taken at the installation site before order is placed. Proper pump sizing will improve heater performance and help ensure heater longevity.

FUTERA II INSTALLATION AND OPERATION INSTRUCTIONS

Table 8 - Futera II Heat Exchanger Selection

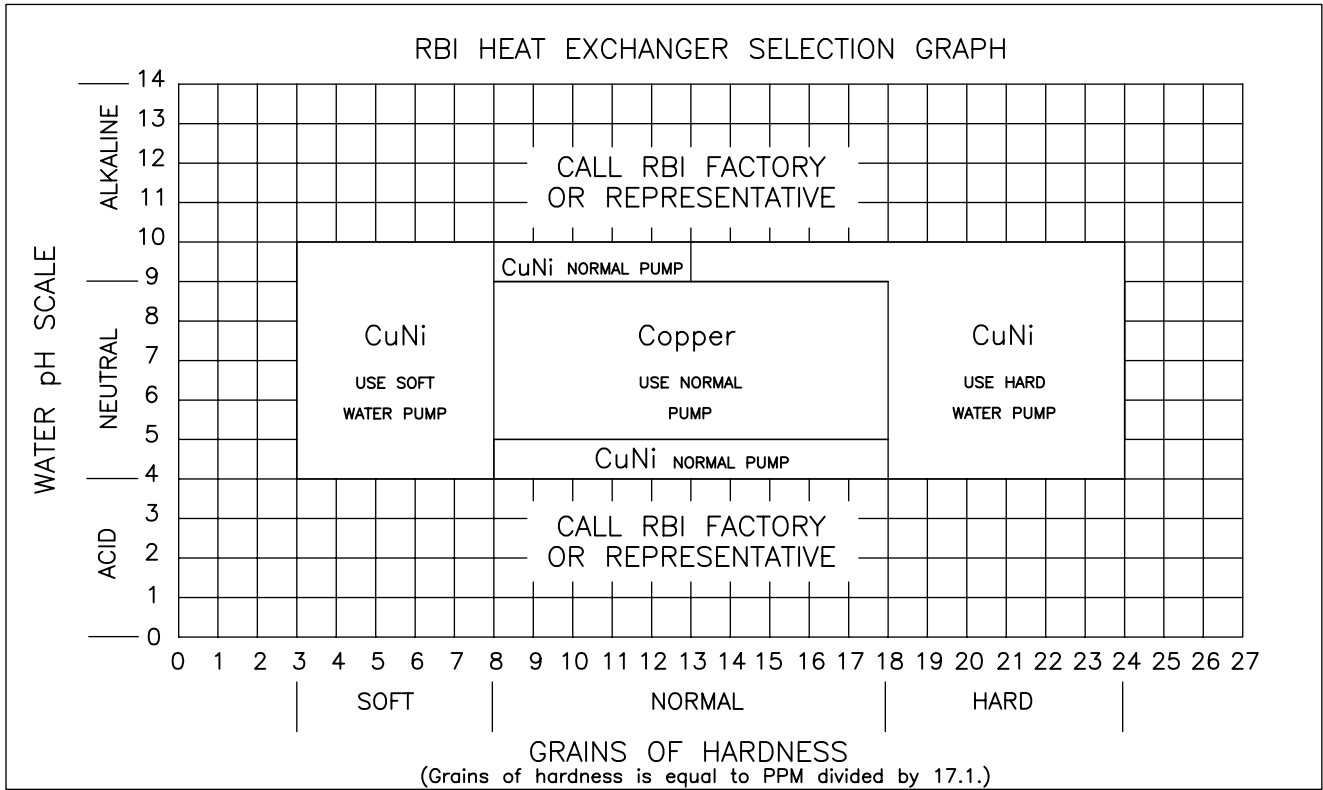

Copyright Pending, MESTEK 12/03

Table 9 - Futera II Pumping Performance Requirement

FUTERA II PUMPING PERFORMANCE REQUIREMENTS

WATER HARDNESS HEAT EXCH. TYPE	SOFT			NORMAL			HARD		
	CuNi			Copper			CuNi		
MODEL	GPM	ΔP	ΔT	GPM	ΔP	ΔT	GPM	ΔP	ΔT
FW-500	37	0.42	23.0	75	1.50	11.0	90	2.11	9.0
FW-750	37	0.59	34.0	75	2.11	17.0	90	2.96	14.0
FW-1000	37	0.75	45.0	75	2.72	23.0	90	3.82	19.0
FW-1250	52	0.57	40.0	105	2.07	20.0	131	3.12	16.0
FW-1500	52	0.69	49.0	105	2.49	24.0	131	3.76	19.0
FW-1750	52	0.81	57.0	105	2.91	28.0	131	4.40	23.0
FW-2000	52	0.92	63.0	105	3.33	32.0	131	5.04	25.0

ΔT=Temperature Change=(Outlet Temp.-Inlet Temp.) in F.
 ΔP=Head Loss=(Inlet Pres.-Outlet Pres.) in feet of Water Column.
 To achieve the proper flow rate adjust outlet valve on heater piping to obtain the correct ΔT.
 Call factory if grains of hardness is less that 3 or greater than 24.

SPECIAL REQUIREMENTS
 (CALL FACTORY OR REPRESENTATIVE)

Copyright Pending, MESTEK 12/03

FUTERA II INSTALLATION AND OPERATION INSTRUCTIONS

Expansion Tank

An expansion tank or other means to control thermal expansion must be installed in the water heating system if back flow prevention devices are installed.

Pump Requirements

This low-mass water heater requires a continuous minimum water flow for proper operation. Table 9 provides the heat exchanger pressure drop chart and temperature rise table. **The temperature rise across the water heater must never exceed 35°F, 19.4°C.**

Cold Water Supply

The cold water supply must be piped to the water heater's outlet piping between the water heater and the hot water storage tank. This will prevent untempered water from entering the water heater, see the Temperature Rise Control section below. Two typical water heating systems are shown in Figures 16 & 17.

Temperature Rise Control

Water returned to the water heater inlet must not be less than **125°F, 52°C** or excessive condensation of the products of combustion will damage the water heater voiding the warranty. The method outlined below can be employed to prevent this condition from occurring.

A balancing valve should be installed on the outlet side of the water heater for purposes of adjusting the flow rate through the heat exchanger. Thermometers are installed on both the inlet and outlet of the water heater for determining the temperature rise through the unit.

The proper velocity through the water heater must be maintained in accordance with Table 9 for efficient operation and long life. If the temperature rise through the water heater is lower than recommended the water velocity is too high. Premature erosion of the heat exchanger will occur. Conversely, if the temperature rise is higher than recommended in Table 9 the flow rate is too low. Scaling and softening of the heat exchanger will occur.

Thermostatic Mixing Valve – Water Above 140°F, 60°C

Water can be stored at temperatures above **140°F, 60°C** provided that a thermostatically controlled mixing valve is used to temper the hot water to an acceptable temperature before it's supplied for domestic use.

The mixing valve **MUST** be set to prevent a scald injury from occurring, see the caution against scalding.

Storage of water for domestic use above **140°F, 60°C** will provide an increased quantity of tempered water and help prevent the growth of water born bacteria.

FUTERA II INSTALLATION AND OPERATION INSTRUCTIONS

Figure 16 - Typical Water Heating Piping (FW Models Only)
(See Notes)

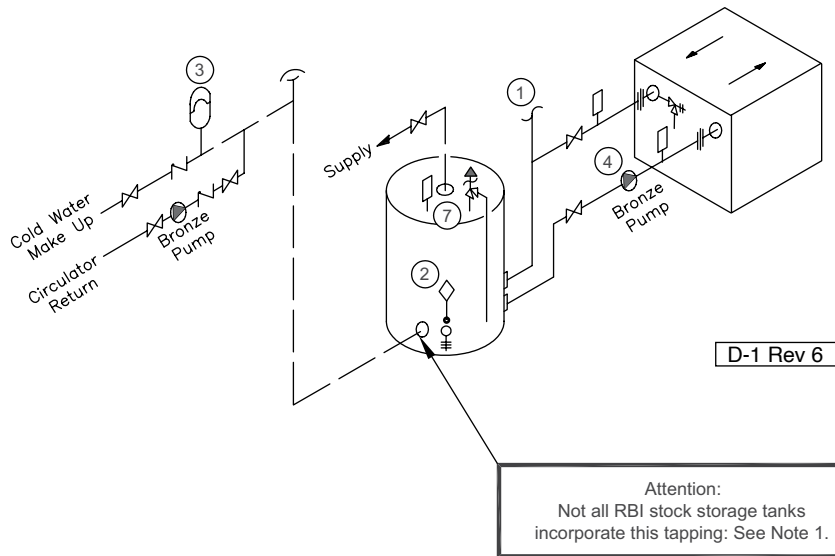

LEGEND:

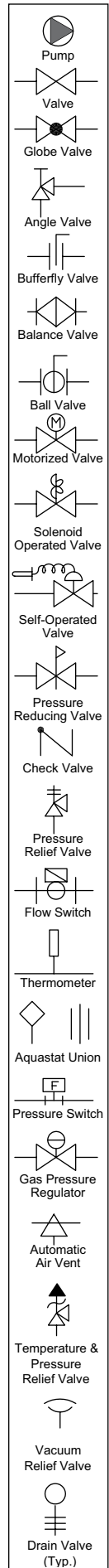
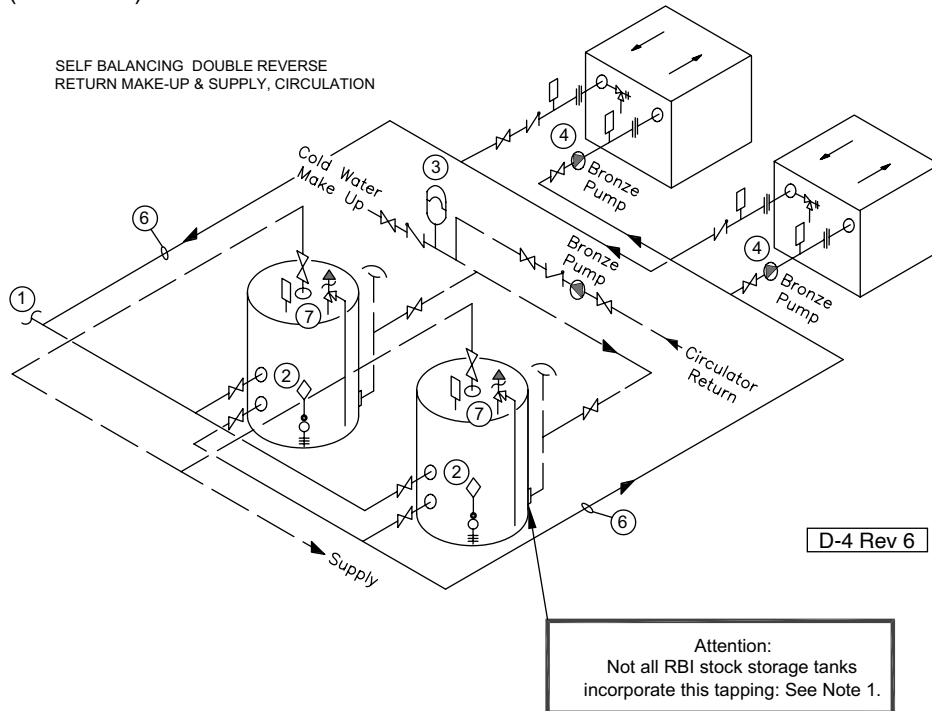

Figure 17 - Multiple Water Heating Piping (FW Models Only)
(See Notes)



NOTES:

1. Optional cold water make up and recirculation line location.
2. When using intermittent pump and pump delay, locate remote aquastat well in lower 1/3 of tank. Install aquastat with heat sensing compound.
3. Thermal expansion tank may be required, check local codes.
4. When using optional factory mounted pump, max pipe length 30 ft. total, 6-90° elbows, full pipe size.
5. CAUTION: MEASURE WATER HARDNESS AND pH AT JOB SITE.
The pH and water hardness must be measured before selecting heat exchanger and pump. Consult the Heat Exchanger Graph and Pumping Performance Table before making selection.
6. Common piping must be sized for maximum combined heater flow.
7. Hot water tanks should be equipped with a combination temperature & pressure relief valve.
8. Boilers may require a mixing application in order to prevent flue gas condensation and premature failure caused by fireside corrosion. (Figure 14A) - "Adjustments Procedure To Maintain Inlet Temperature Above Dew-point."
9. A thermostatic mixing valve may be required at the outlet of the tank in order to limit the mixed water to a desirable temperature helping to prevent scalding and injury. Consult local codes.

Notice: These drawings show suggested piping configuration and valving. Check with local codes and ordinances for specific requirements.

FUTERA II INSTALLATION AND OPERATION INSTRUCTIONS

GAS SUPPLY PIPING

WARNING Check the boiler/water heater rating plate to make sure that the boiler/water heater is for the type of gas that will be used. If it isn't, do not connect the boiler/water heater to the gas supply. Gas supply piping must be in accordance with the National Fuel Code, ANSI Z223.1-latest revision or applicable provisions of the local building codes. Canadian installations must comply with CAN/CGA B149.1 or .2 Installation Code. Failure to comply with this warning can result in extensive property damage, severe personal injury or death!

The Futera II comes from the factory ready to be piped to the gas supply. If for any reason the boiler/water heater is not for the type of gas available at the installation site, call your RBI representative to resolve the problem.

NOTICE A minimum gas supply pressure of 5 in, 127 mm W.C. natural or 11 in, 279 mm WC propane and maximum 14 in, 356 mm WC natural or propane, must be available at the safety shutoff valve inlet with the unit(s) operating, and not to exceed (1.0 in WC) drop when firing from minimum input to full load of the gas supply line and all appliances running.

Do not size the gas supply line nominal iron pipe size based only on the boiler gas inlet connection size. The gas supply line (feed) to the boiler gas inlet connection must be designed per an engineered method and utilizing (Table 10) to ensure that the gas supply piping is sized properly. Do not neglect the pressure drop due to pipe fittings. (Table 10) should be used in conjunction with (Table 11) to ensure that the gas supply piping has the capacity to meet the demand. If more than one appliance is supplied by the same supply pipe, the piping must be sized based on the maximum possible demand.

Figure 18 depicts the proper way to connect the boiler/ water heater to the gas supply piping. The manual shut-off valve **MUST** be installed in the supply piping. It should be installed **5 ft, 1.5 m** above the floor where required by local codes. Provide a sediment trap at the bottom of the vertical section of the gas supply pipe upstream of the gas controls.

A ground joint union should be installed between the boiler gas controls and the supply piping. Each of these items are needed to ensure long life and ease of servicing. Always use a pipe sealant that is suitable for use with LP gas.

Table 10 – Gas Pipe Capacity

Maximum pipe capacity in ft³/hr based on 0.60 specific gravity gas at a pressure of 0.5 psig or less and a 0.3" WC pressure drop.

Nominal Iron Pipe Size	Pipe length in feet								
	10	20	30	40	50	60	80	100	150
	Maximum gas volume of pipe, (ft ³ /hr)								
1"	520	350	285	245	215	195	170	150	120
1 1/4"	1050	730	590	500	440	400	350	305	250
1 1/2"	1600	1100	890	760	670	610	530	460	380
2"	3050	2100	1650	1270	1270	1150	990	870	710

Note: Multiply the gas volume by 0.62 for propane flow capacity in ft³/hr. Multiply the propane flow capacity by 2500 Btu/ft³ to determine the propane Btu/hr capacity for a given pipe size and length.

Table 11 – Equivalent Pipe Length

Nominal Iron Pipe Size	Type of pipe fitting			
	90° Elbow	Tee ¹	Gate Valve ²	Gas Cock ²
	Equivalent pipe length, (ft)			
1"	2.6	5.2	0.6	1.5
1 1/4"	3.5	6.9	0.8	1.9
1 1/2"	4.0	8.0	0.9	2.3
2"	5.2	10.3	1.2	3.0

Notes: 1. For flow through branch.
2. For flow at full open.

Figure 18 – Gas Supply Piping

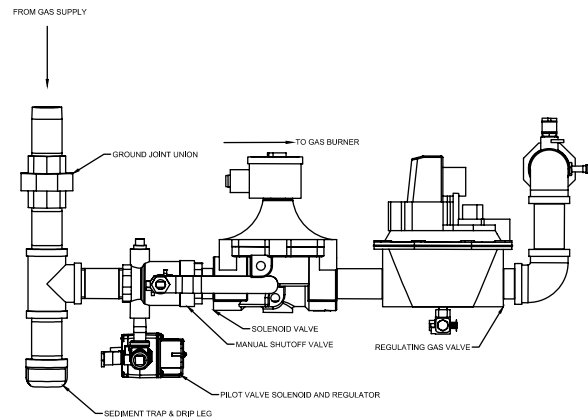

CAUTION Always use a wrench on the gas valve body when making gas connections to it. Never over-tighten the piping entering the gas valve body or gas valve failure may result!

When applicable, provisions for vent, bleed and gas relief lines must be made in accordance with the latest revision of ANSI Z223.1/NFPA 54.

Safe lighting and other performance criteria were met with the gas manifold and control assembly provided on the boiler. All gas connections **MUST** be leak tested before putting the boiler into operation.

WARNING Never use an open flame to test for gas leaks. Always use an approved leak detection method. Failure to comply with this warning can cause extensive property damage, severe personal injury or death!

Whenever the gas supply piping is pressure tested the boiler/water heater gas controls must be protected. If the test pressure is equal to, or less than **1/2 psig, 3.5 kPa** isolate the boiler/water heater by closing its manual shut off valve, see Figure 18. If the test pressure is greater than, or equal to **1/2 psig, 3.5 kPa**, disconnect the boiler/water heater and its individual shut-off valve.

FUTERA II INSTALLATION AND OPERATION INSTRUCTIONS

ELECTRICAL WIRING

Electrical Power Connections

CAUTION Label all wires prior to disconnection when servicing controls. Wiring errors can cause improper and dangerous operation! Verify proper operation after servicing.

The electrical connections to this boiler/water heater must be made in accordance with all applicable local codes and the latest revision of the National Electrical Code, ANSI/NFPA-70. Installation should also conform with CSA C22.1 Canadian Electrical Code Part I if installed in Canada.

A properly rated shut-off switch should be located at the boiler/water heater. The boiler/water heater must be grounded in accordance with the authority having jurisdiction, or if none, the latest revision of the National Electrical Code, ANSI/NFPA-70.

Line voltage field wiring of any controls or other devices must conform to the temperature limitation of type T wire at **95°F, 35°C** above room temperature. Use copper conductors with a minimum size of #14 awg. Use appropriate wiring materials for units installed outdoors.

Refer to the wiring diagram supplied with the boiler/water heater for proper wiring connections and boiler full load amperage (FLA).

GENERAL OPERATION

WARNING Before proceeding read and fully understand the instructions contained in this manual. Do not attempt to operate this boiler/water heater if it has not been installed in accordance with the guidelines set forth in this manual. Failure to comply with this warning can result in extensive property damage, severe personal injury or death!

Should overheating occur or the gas supply fail to shut off, turn off the manual gas control valve to the appliance. Do not interrupt water flow through the boiler/water heater.

Hydronic Heating Boilers

Open the make-up water valve and slowly fill the boiler and all of the radiation with water. Ensure that all bleed and drain valves are closed.

Adjust the make-up water pressure regulator so a minimum **12 psig, 82.7 kPa** system pressure is maintained at the highest point in the system piping. If a make-up water pump is used adjust it to maintain a minimum **12 psig, 82.7 kPa** system pressure.

Open the system bleed and drain valves, one at a time, to purge the air trapped in the heating system piping.

With the boiler off, run the system pump for at least 30 minutes and bleed the system piping using the bleed valves. If strainers are used in the system piping, the make-up water valve should be closed and the strainers checked and cleaned.

The system expansion tank should be checked to ensure that the correct water level in the tank is maintained. The tank should be less than half full of water with the system full and adjusted to the correct operating pressure.

Start the boiler as described in the “OPERATING INSTRUCTIONS” section. Run the boiler for at least an hour. The system pump(s) and all radiation units must be operated during this time. Ensure that the make-up water valve is open.

Shut the boiler off and open the bleed valves to purge the air trapped in the heating system piping. Close the make-up water valve and check and clean the strainers and make-up water pressure reducing valve.

Open the make-up water valve and adjust the system pressure if necessary. The system should be checked and bled after three days of operation.

OPERATING INSTRUCTIONS

FOR YOUR SAFETY READ BEFORE OPERATING.

- A. This appliance is equipped with an ignition device which automatically lights the pilot. Do not try to light the pilot by hand.
- B. BEFORE OPERATING smell all around the appliance area for gas. Be sure to smell next to the floor because some gas is heavier than air and will settle on the floor.

FUTERA II INSTALLATION AND OPERATION INSTRUCTIONS

DANGER: Propane gas may not always be detected by smell. Propane gas is heavier than air and can collect in low areas.

Propane gas can ignite or explode if an ignition source is present and result in death, serious injury and property damage!

FOR YOUR SAFETY

- Have only qualified licensed professionals install, service and maintain this appliance and your gas system in accordance with all applicable codes.
- If you suspect a leak:
 1. Have everyone leave the building immediately.
 2. Do not attempt to light any appliance.
 3. Do not touch any electrical or electronic switches in the building.
 4. Do not use any phone in the building.
 5. Call your gas supplier from a phone outside of the building.
 6. If you cannot reach your gas supplier call the fire department.

- C. Do not use this appliance if any part has been under water. Immediately call a qualified service technician to inspect the appliance and to replace any part of the control system and any gas control that has been under water.

CAUTION To prevent being burned, stand clear of the boiler during ignition and don't touch any hot metal parts!

Operating Instructions

1. **STOP!** Read the safety information above. If, at any time, the appliance will not operate properly, follow the instructions "TO TURN OFF GAS TO APPLIANCE".
2. Set the operating control or thermostat to off or its lowest setting.
3. Turn off all electric power to the appliance.
4. Close the manual main and pilot gas shut-off valves.

5. Wait five (5) minutes to clear out any gas. Then smell for gas, including near the floor. If you smell gas, **STOP!** Follow "B" in the safety information above (to the left) on this label. If you do not smell gas, go to the next step.
6. Connect a manometer having a minimum capacity of **20 in, 508 mm WC** to the gas pressure test port, see Figure 22. Make sure that the gas supply piping has been purged of air and that all gas joints up to the gas valve have been thoroughly checked for leaks.
7. Open the manual pilot valve.
8. Turn on all electric power to the boiler.
9. Set the operating control or thermostat to the desired setting.
10. The pilot should automatically light. Do not try to light the pilot by hand!
11. With the pilot lit, open the main gas shut-off valve.
12. The burner should light with proper boiler operation.

To Turn Off Gas To Appliance

1. Set the operating control or thermostat to its lowest setting.
2. Turn off all electric power to the appliance if service is to be performed.
3. Close the manual main and pilot gas shut-off valves.

FUTERA II INSTALLATION AND OPERATION INSTRUCTIONS

CHECKING & ADJUSTMENTS

On initial light-off, the installer may alter the preset factory settings to attain satisfactory combustion. An accurate manometer and flue gas analyzer must be used. Please see **Fire Testing** section 4 for combustion guidelines.

Spark Gap

With the main and pilot gas manual valves in the closed position energize the unit. Observe the trial for ignition to confirm that the spark is strong and continuous. If not, check and adjust the spark gap as shown in Figure 19.

Figure 19 – Spark Gap

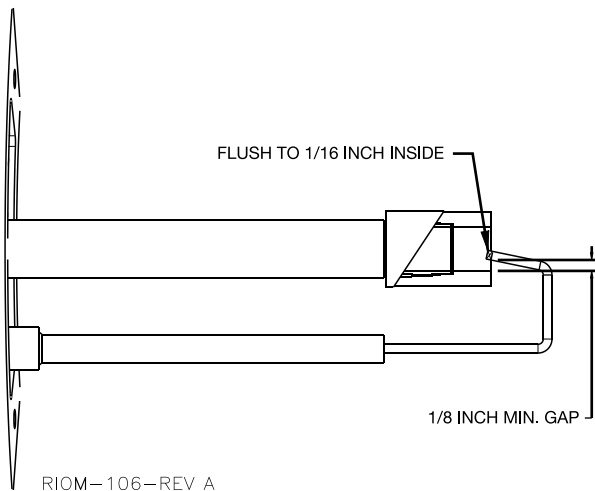

Pilot Operation

The pilot pressure has been factory set at 3 in. WC for natural and LP gas and shouldn't need adjustment. To check the pilot pressure close the manual main shut-off valve and the pilot gas shut-off valve, Figure 18. Remove the 1/8" pipe plug from the pilot tee and connect a manometer having a minimum range of 6 in, 152 mm WC to it. Open the pilot gas shut-off valve. With the unit powered, generate a call for heat. When the prepurge is complete the ignition/pilot trial will begin. At this point put the Honeywell RM7800 test switch in the test position. The control will hold in the ignition/pilot sequence allowing you to check the pressure.

To adjust the pilot the following steps must be taken:

1. Remove the pilot gas pressure regulator cap.
2. Turn the pressure regulator adjustment screw clockwise to increase the flame and counterclockwise to decrease it.
3. Replace the pressure regulator adjustment screw cap.

Fire Testing

1. For an on/off unit confirm that the low-fire side of the two-stage gas valve is set to its maximum setting. For a two-stage unit a 1/16 in. thick silicon spacer should be installed under the low-fire adjusting screw.

Without this spacer it won't be possible to consistently set the low-fire pressure to 2.4 in, 61 mm WC.

2. Follow the instructions in the "OPERATING INSTRUCTIONS" section starting on page 28 to fire the main burner. Upon ignition of the main burner adjust the high fire adjusting screw to obtain the high fire pressure listed in Table 12. On a two-stage unit disconnect the power from the high fire side of the gas valve and adjust the low fire, regulator. If the unit short cycles on low fire adjust the air box pressure and gas back pressure as outlined below.

CAUTION Never force the regulator adjustment screw beyond the stop limits or damage to the regulator will occur!

Table 12 – Pressure Settings, Inches W.C.

Model Size	Natural Gas				LP Gas			
	Low		High		Low		High	
	in	mm	in	mm	in	mm	in	mm
500	n/a	n/a	2.3	58	n/a	n/a	4.0	102
750	2.4	61	3.0	76	6.0	152	7.0	178
1000	2.4	61	3.0	76	6.0	152	7.0	178
1250	2.4	61	3.0	76	6.0	152	7.0	178
1500	2.4	61	3.0	76	6.0	152	7.0	178
1750	2.4	61	3.0	76	6.0	152	7.0	178
1950	2.4	61	3.0	76	6.0	152	7.0	178

3. When fire tested at the factory the unit's input was rated and the gas pressure(s) recorded on the test label affixed to the jacket next to the junction box. To confirm the input of the unit follow the instructions in the **INPUT RATE** section below. The gas pressure setting(s) for dual fuel units may vary; refer to the test label on the unit.
4. An undiluted flue gas sample must be taken at the flue outlet using a calibrated flue gas analyzer. Allow the unit to run for 15 minutes before taking the sample. For a natural gas unit the low fire CO₂ reading should be 7.3%-7.5% and 8.5%-8.8% for propane gas. The high fire CO₂ reading should be 7.5%-8.0% and 8.8%-9.4% for propane gas. Exceeding 8.0% on natural gas or 9.4% on propane gas CO₂ will shorten the life of the burner. Adjust the inlet air damper to achieve the correct CO₂ readings.
5. If the pressure settings vary from those listed in Table 8, please affix a new label or notice to the boiler, which shows these new settings. However, do not sacrifice or compromise safe combustion, carbon monoxide limits, or safety settings to achieve these figures. The pressures listed in Table 12 are guidelines obtainable under ideal conditions.
6. To test the ignition safety shutoff device, close the manual shutoff valve in the gas supply line. Within 5 seconds of main burner flame extinction, the main gas valve solenoid should close with an audible noise. After 15 seconds the module should lockout and the trial for

FUTERA II INSTALLATION AND OPERATION INSTRUCTIONS

ignition end. After 5 minutes a second trial for ignition should occur. Open the manual shutoff valve in the gas supply line and reset the ignition control system. A normal ignition sequence should take place. If the burner hasn't lit after the last ignition try, the gas valve will close and the system will go into lock out only on CSD-1 units otherwise, the boiler will retry every 5 minutes. Inspect the ignition system to determine what the problem is.

7. With the main burner in operation, close the manual firing valve. As soon as the main burner flames go out, open the manual firing valve. A normal ignition sequence should take place. If the burner fails to light the system will make one more ignition attempt.
8. With the burners in operation, interrupt the power to the control circuit by lowering the operating control or thermostat. The main burners should go out. Reset the operating control or thermostat, a normal ignition sequence should follow.

Air Box Pressure

Connect a manometer to the air box pressure tap located behind the control cover, Figure 21.

Table 13 lists the factory settings for the air box pressure and gas back pressure that were set using a minimum length of vent pipe. It may be necessary to adjust the air shutter on the blower to achieve acceptable combustion readings for certain installations.

Figure 21 – Air Box Pressure Tap

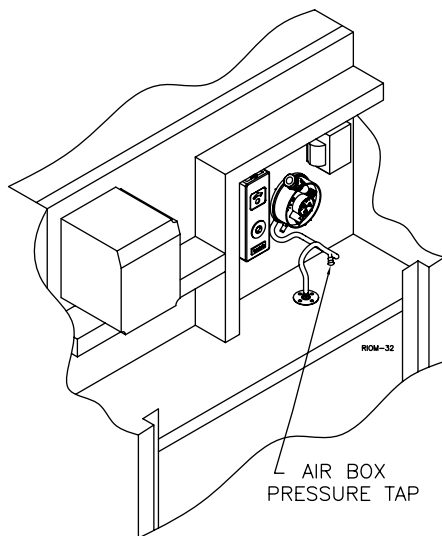

If vented vertically ensure that the barometric damper is capable of maintaining the air box pressure listed in Table 13. An air box pressure lower than that listed in Table 13 can significantly reduce the life of the burner.

Long horizontal vents will result in an air box pressure higher than that listed in Table 13. It may be necessary to open the air damper to obtain the correct combustion settings.

Required Gas Pressure

Connect a manometer to the gas pressure test port upstream of the firing valve, Figure 22. Close the manual shut off valve for the pilot gas. Ensure that the firing valve is in the open position. Energize the unit and allow it to try for ignition until it goes into flame failure. If the gas back pressure is significantly different from that listed in Table 13 the air/gas mixing tube may be misaligned.

Provide gas supply pressure at inlet to boiler gas train as follows:

	LP	Nat
Minimum (in WC)	11	5
Maximum (in WC)	14	14

Measure pressure when the boiler is firing at full rate. Low gas pressure could indicate undersized gas line or insufficient gas supply.

“Static and operating gas pressure required at the gas valve inlet is between 5 in. WC and 14 in. WC for natural gas and 11 in. WC and 14 in. WC for propane and not to exceed a maximum of (1.0 WC) drop when firing from minimum input to full load of the gas supply line and all the appliances running. If the gas pressure is above this limit, a lock-up style regulator suitable for dead end service such as an Equimeter or Fisher must be installed to prevent increase (creep) of gas pressure when the units are not operating. This pressure regulator (supplied by others) may be installed at the service entrance to each unit or a “master” regulator sized to handle multiple units may be utilized. Consult local gas utility or regulator manufacturer for recommendations to meet specific job site requirements.”

Figure 22 – Air Adjustment & Gas Pressure Test Port

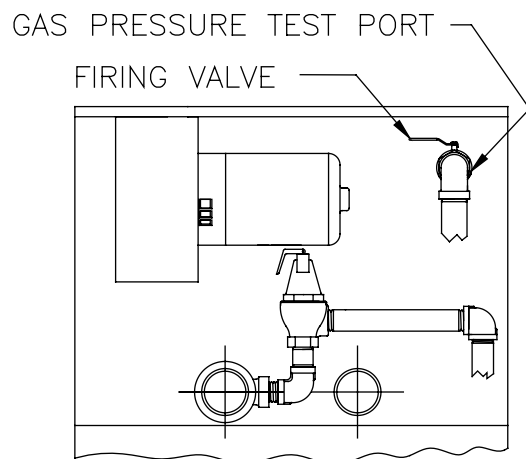

FUTERA II INSTALLATION AND OPERATION INSTRUCTIONS

Table 13 – Pressure Settings, WC

Model Size	Air Box Pres.		Gas Back Pres.	
	in	mm	in	mm
500	1.3	33	0.3	7.6
750	2.1	53	0.6	15.2
1000	3.0	76	0.6	15.2
1250	2.1	53	0.3	7.6
1500	2.5	64	0.3	7.6
1750	3.2	81	0.3	7.6
1950	3.4	86	0.3	7.6

Input Rate, Natural Gas

Gas appliances are rated based on sea level operation with no adjustment required at elevations up to **2000 ft, 610 m**. At elevations above **2000 ft, 610 m** input ratings should be reduced by 4% for each **1000 ft, 305 m**.

Check the input rate as follows:

1. Turn off all other gas appliances that use the same gas meter as the boiler/water heater.
2. Call your gas supplier and ask for the heating value of the gas.
3. Start the boiler/water heater and let it run for 15 minutes.
4. Using the gas meter and a stopwatch, clock the time that it takes to burn **10 ft³, 0.28 m³** of gas and divide this time by 10.
5. Insert the heating value and the time, in seconds, into the formula below.
6. $\text{Input} = (\text{heating value, Btu/hr})(3600)/(\text{time, seconds})$
7. If the computed rate deviates by more than 5% from the rated input value of the unit adjust the manifold pressure accordingly. DO NOT adjust the manifold pressure by more than 5%. If a proper rate cannot be maintained without adjusting the manifold pressure beyond the 5% limit, the main burner orifices must be replaced. If the input rate is too low, go to the next larger size of main burner orifices. If the input rate is too high, go to the next smaller size.

CAUTION Never increase the input to the boiler/water heater above that for which it is rated. Doing so can cause premature failure of the boiler!

CONTROL DESCRIPTION

Low Water Cutoff

If the boiler is to be installed above radiation or if required by other codes or regulations, install a low water cutoff in appropriate piping. Wire the switch and any external controls in series to the “Interlock” contacts in the control box, see the wiring diagrams included with the unit for details. Ensure that the low water cutoff device(s) will function properly.

Boiler Thermostat

If a thermostat is to be used to control the boiler always follow the instructions included with the thermostat. Proper location of the thermostat will ensure efficient trouble-free operation of the boiler. Mount the thermostat to an inside wall at a height approximately **5 ft, 1.5 m** above the floor.

Avoid placing the thermostat in areas that will not provide an accurate measurement of the room temperature. Locating the thermostat behind a door, in an alcove, close to a source of thermal radiation or in a drafty area will cause poor or sporadic heating.

For a thermostat that employs an adjustable heat anticipator, adjust the anticipator to match the current measured in the thermostat circuit. An increased anticipator setting may be necessary if the unit cycles frequently. If the room temperature over-shoots the thermostat setting, reduce the anticipator setting.

Operating Control

The operating control on the water heater is set to its lowest setting when the water heater leaves the factory. The preferred control setting for potable hot water is **130°F, 54°C**. The operating control should be set to the lowest setting that will satisfy the consumer's needs.

SP Setpoint or Target Temperature:

The Setpoint is the inlet water temperature that the operating control will try to match by staging the boiler between Off, Stage 1 - D1 and Stage 2 - D2.

1. Press and hold the up button for up to 3 seconds to activate the set point change. The set point parameter field will be visible on the display screen. Use the up/down arrows to change the result to the desired temperature setting.
2. Press the OK button to save the value.

D1 Boiler Differential:

The Boiler Differential is centered around the set point so that when the sensor reads 1/2 of D1 below the set point, stage 1 will be energized. When the sensor reads a temperature 1/2 of D1 above the set point, stage will turn off.

1. From the display home screen press the OK button for up to 1-3 seconds to enter the menu screen. Press OK to enter the User Level. Use the up/down arrows to scroll to the d1 parameter. Press the OK button then use the up/ down button to change to the desired value. Press the OK button to store the value.
2. Press the return button repeatedly to get back to the home screen.

FUTERA II INSTALLATION AND OPERATION INSTRUCTIONS

D2 Boiler Differential:

The Interstage Differential is the difference in temperature between stage 1 being called on, and stage 2 being called on.

1. From the display home screen press the OK button for up to 1-3 seconds to enter the menu screen. Press OK to enter the User Level. Use the up/down arrows to scroll to the d2 parameter. Press the OK button then use the up/ down button to change to the desired value. Press the OK button to store the value.
2. Press the return button repeatedly in order to get back to the home screen.

Temperature Scale:

Use the following steps to change the temperature scale.

1. From the display home screen press the OK button for up to 1-3 seconds to enter the menu screen. Scroll to the Configuration level and press OK. Then press the OK button to enter the System level. Use the up/down arrows to scroll to the temperature parameter. Press the OK button then use the up/down button to change to the desired temperature scale. Press the OK button to store the value.
2. Press the return button repeatedly to get back to the home screen.

⚠WARNING Setting the thermostat or operation control too high can result in scalding resulting in severe personal injury!

High Limit (Aquastat)

The high limit is located in the top control area of the boiler/ water heater. A remote capillary bulb is run to a well on the outlet side of the supply header. The high limit can be reset by depressing the red button.

The water heater high limit should be set a minimum of **20°F, 11°C** higher than the operating control. Refer to the HOT WATER SUPPLY section for the proper supply water temperature.

Flow Switch

The flow switch is provided to prove flow is present through the boiler. The temperature rise across the primary heat exchanger must never exceed 35°F, 19.4°C.

DIAGNOSTICS

The Futera II has a number of indicator lights that are intended to display the current operation and to indicate any possible problems. The function of each light is listed below.

On/Off Switch: The toggle switch will illuminate when power is being supplied to the unit.

Call For Low Fire: This green light will illuminate when there is a low fire heat demand either from the RBI Temperature Controller or a Building Management Control.

Call For High Fire: This green light will illuminate when there is a high fire heat demand either from the RBI Temperature Controller or a Building Management Control.

Trial Ignition: This yellow light will illuminate when the pilot gas valve is energized.

Main Burner: This green light will illuminate when the main gas valve is energized.

High Limit: This red light will illuminate when the outlet water temperature has exceeded the setting on the High Limit control during call for heat.

Low Water: This red light will illuminate when there is not proper water flow during a call for heat.

Low Air Flow: This red light will illuminate when there is not proper combustion air flow during a call for heat.

Flame Failure: Illuminate whenever the ignition control is unable to establish a pilot flame within the trial for ignition period. This light will also illuminate if the Flame Safeguard Ignition Control is in lockout for other reasons.

FUTERA II INSTALLATION AND OPERATION INSTRUCTIONS

MAINTENANCE

⚠ WARNING Disconnect electrical power and close the manual gas shut off valve before performing maintenance or severe personal injury may result!

⚠ CAUTION Servicing, inspection and adjustment must be done by a trained technician in accordance with all applicable local and national codes. Improper servicing or adjustment can damage the boiler/water heater!

The boiler/water heater combustion system must be inspected at least once a year and before each heating season. Make sure that the burner and ignition components are free from dust, soot, dirt, corrosion or other deposits that would impair the boiler/water heater's performance. Refer to page 37 for component identification.

⚠ CAUTION Improper burner servicing can result in premature burner failure voiding the warranty!

Burner/Heat Exchanger Inspection

1. Close the manual shutoff valves in the gas supply lines and turn off electrical power to the boiler/water heater.
2. Remove the jacket top panel.
3. Remove the combustion chamber top panel.
4. Remove the air gas mixing tube.
5. Disconnect the pilot tubing and ignition/sensing lead from the burner.
6. Remove the four nuts that attach the burner to the heat exchanger.
7. Carefully lift the burner out of the unit.
8. Inspect the burner for damage or signs of deterioration. Use a brush or compressed air to remove any debris from the burner ports.
9. DO NOT install a damaged or badly corroded burner, replace it.
10. Inspect heat exchanger, proceed to the following sections, (page 31), if further inspection or cleaning is required.
11. Install the burner making sure that the burner gasket is not torn or deteriorated. If it is, replace it.
12. Reassemble the unit following the removal steps in reverse order.

Heat Exchanger Inspection

1. Close the manual shutoff valves in the gas supply lines and turn off electrical power to the boiler/water heater.
2. Remove burner following the instructions in the **Burner Removal & Inspection** section.
3. Remove the front jacket panel and combustion chamber door.
4. Inspect the inside and outside of the heat exchanger for signs of damage, sooting or corrosion.
5. The outside surfaces of the copper tubes should be free of any soot deposits. A slight black smudge is normal with some types of gases. Black soot indicates poor combustion. Green deposits indicate condensation due to low return water temperatures. In either case the heat exchanger must be cleaned thoroughly and the problem resolved before the boiler/water heater is returned to service.

6. If there are no signs of damage, sooting or corrosion, reassemble the unit following the previous steps in reverse order.
7. A badly corroded or damaged heat exchanger must be replaced, see the **Heat Exchanger Repair & Replacement** section.

Heat Exchanger Cleaning

1. Close the shut off valves in the inlet and outlet piping. On heating systems close the system fill valve and relieve the system pressure from the boiler by carefully lifting the relief valve or opening the drain valve.
2. Disconnect the boiler/water heater from the system piping.
3. Remove the eight bolts on the rear pipe enclosure panel.
4. Remove the front jacket panel and combustion chamber door.
5. Slide the heat exchanger out of the unit.
6. Remove the "V" baffle straps and "V" baffles.
7. Thoroughly clean the heat exchanger with water from a high-pressure hose. Use a soft bristle brush if necessary.
8. Replace the cleaned heat exchanger and other components in the reverse order of their removal.

NOTICE Follow section "Operating Instructions" for recommissioning. (Record pressure readings and combustion values for next inspection cycle).

Heat Exchanger Repair & Replacement

1. A leaking or otherwise damaged tube(s) can be replaced as outlined in steps 2 through 8.
2. Remove the heat exchanger from the boiler/water heater as outlined in the **Heat Exchanger Cleaning** section.
3. Remove the pipe plugs from the inlet/outlet and return headers opposite from the ends of the tube(s) being replaced.
4. Carefully cut the damaged tube(s) in half taking care not to damage the adjacent tubes and remove.
5. Install and swage/expand in place the new tube(s).
6. Replace the pipe plugs using a suitable tread sealant on each one.
7. Sagging or distorted heat exchanger tubes are an indication of low water flow through the system. A damaged heat exchanger must be replaced and the condition that caused the damage resolved before the boiler/water heater is returned to service.
8. Replace the heat exchanger and other components in the reverse order of their removal.
9. The torque values for the bolts that secure the removable headers are 30-50 ft lbs. Once bolts have been started and secured the tightening sequence is as follows:
 - 1) Middle top
 - 2) Middle Bottom
 - 3) Right Top
 - 4) Left Bottom
 - 5) Left Top
 - 6) Right Bottom

Air Intake & Vent System

Thoroughly inspect the vent system for any signs of blockage, corrosion or leakage and periodically clean screen in vent terminal (where applicable). Immediately replace any unsound vent system piping.

FUTERA II INSTALLATION AND OPERATION INSTRUCTIONS

Controls

Use the "GENERAL OPERATION" and "CHECKING AND ADJUSTMENTS" sections of this manual for reference.

1. Check the thermostat or operating controls for proper operation.
2. A float type low water cutoff device must be flushed out per the manufacturers' instructions. The probe on a probe low water cut off must be removed, cleaned and inspected at least once a year. Ensure that the low water cutoff operates properly. If not, replace them.
3. The flow switch contacts must be open when water flow is not present.
4. The relief valve should not weep or discharge water at normal system pressure - this may be due to thermal expansion in a closed water supply system. If it does, contact a qualified service technician to have it inspected. NEVER try to clean or repair the relief valve! If the valve fails to operate properly, have it replaced!
5. The aquastat high limit controls the maximum water temperature in the boiler. It is adjustable from **140°F, 60°C** to **250°F, 121°C**. If the water temperature reaches the set temperature before the demand for heat has been met, the aquastat high limit should shut the boiler off. The water temperature should never exceed the maximum set point of **240°F, 116°C**, for boilers and **210°F, 99°C** for water heaters. The aquastat high limit cannot be repaired. If it fails to function properly, replace it.
6. Visually check the pilot and main burner flames to ensure proper operation, see Figures 19 & 23.

⚠WARNING

A yellow, floating flame indicate a lack of combustion air. Do not operate the boiler/ water heater until the problem is solved or severe personal injury or death may occur!

Figure 23 – Main Burner Flame

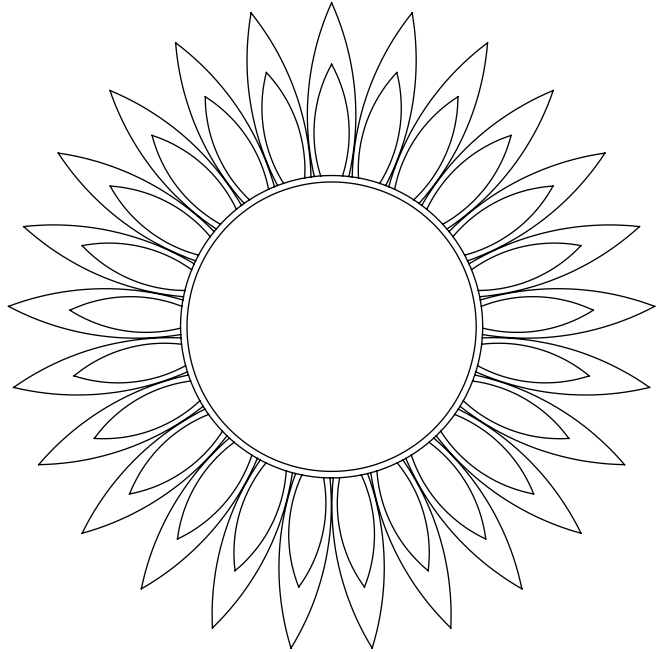

FUTERA II INSTALLATION AND OPERATION INSTRUCTIONS

TROUBLE-SHOOTING

OPERATIONAL PROBLEMS	CORRECTIVE ACTION
1. The On/Off toggle switch doesn't illuminate.	Ensure that proper voltage is being supplied to the unit. Inspect the circuit breaker for the boiler/water heater circuit. Ensure that the power switch operates properly and is wired correctly. Check the transformer for proper operation.
2. The "Low Water" indicator light illuminates.	Ensure that the boiler/water heater has been completely purged of air. Ensure that the pump is operating properly/rotating in the proper direction. Ensure that all system valves are in the correct position and that no restrictions in the piping are present. Confirm that the flow switch is wired correctly and functions properly.
3. The "Low Air Flow" indicator light illuminates.	Check the light. Inspect the vent and air intake systems to ensure that blockages are not present. Ensure that the vent and air intake systems conform to the guidelines in this manual. Confirm that the blocked flue switch connections are correct and that it is functioning properly. Ensure that the blower air inlet damper & pressure switch are adjusted for the correct air box pressure.
4. The "Trial for Ignition" indicator light illuminates, but the igniter does not spark.	Confirm that the ignition module is properly wired. Confirm that the ignition lead isn't grounded out. Inspect the igniter and ensure that the spark gap is correct. Ensure that the ignition module is properly grounded.
5. The "Main Burner" ignites, but the natural gas high fire manifold pressure is less than 2.5 in. WC	Ensure that at least the minimum inlet pressure is supplied at the inlet of the gas valve.
6. The Boiler/Water Heater rumbles on start up.	Ensure that the burner is set up per the "CHECKING & ADJUSTMENTS" section. Ensure that the unit is properly vented.

FUTERA II INSTALLATION AND OPERATION INSTRUCTIONS

Figure 24 – Exploded View

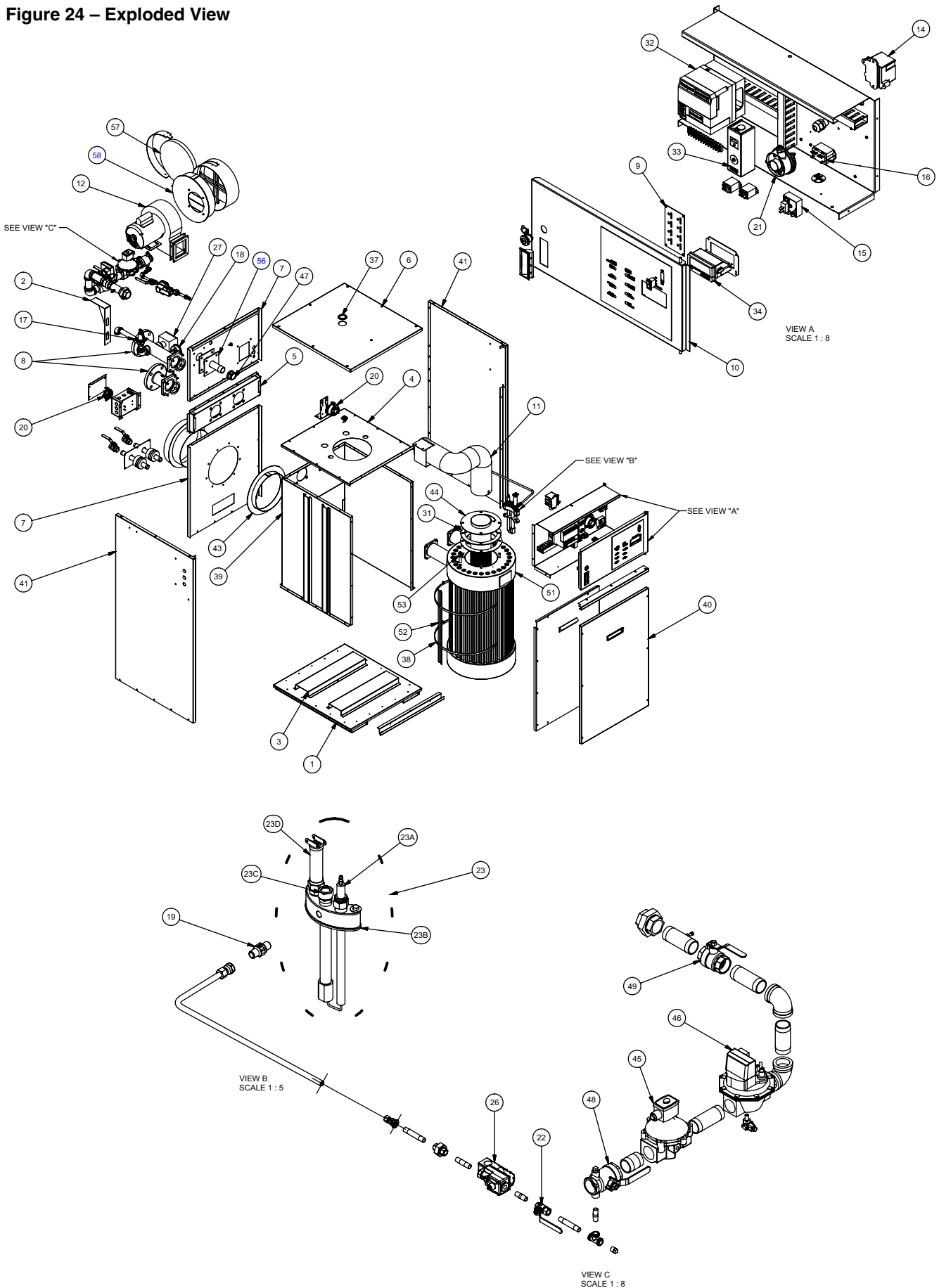

FUTERA II INSTALLATION AND OPERATION INSTRUCTIONS

Futera II Model Size with Item Quantities Below									
Ref #	Name of Part	Part #	500	750	1000	1250	1500	1750	1950
4	Combustion Chamber Top Panel	03-1731	1	1	1				
		03-1732				1	1	1	1
9	Light Board, 120V	40-0071	1	1	1	1	1	1	1
11	Air/Gas Mixing Tube Assembly	70-2183	1	1	1				
		70-2184				1	1	1	1
12	Fan Assembly, 1/4HP	70-2200K	1	1	1				
	Fan Assembly, 1/2HP	70-2201K				1	1		
	Fan Assembly, 3/4HP (*must replace upper rear panel prior to 1009)	70-2204K*						1	1
13	Pilot Tube Assembly (prior to 06/14) (Consult Factory)	70-2185.1	1	1	1				
	Pilot Screw	57-0356	2	2	2	2	2	2	2
	Pilot Nut	57-0456	2	2	2	2	2	2	2
	Spark Generator	16-0036	1	1	1	1	1	1	1
NS	Purge Timer, ST7800	16-0007	1	1	1	1	1	1	1
NS	Rocker Switch On/Off	48-0012	1	1	1	1	1	1	1
15	Pump Delay Relay, 115AC	15-0114	1	1	1	1	1	1	1
16	Pump Contactor 1PH (fan relay)	15-0118	1	1	1	1	1	1	1
NS	Low Gas Pressure Switch (Manual Reset)	11-0410	1	1	1	1	1	1	1
NS	High Gas Pressure Switch (Manual Reset)	11-0411	1	1	1	1	1	1	1
NS	Hi Limit Relay (R1)/Flame Failure (R2), 120V	15-0125	1	1	1	1	1	1	1
17	Pressure Relief Valve 50#	13-0040	1						
	Pressure Relief Valve 50#	30-0360		1					
	Pressure Relief Valve 50#	30-0374			1	1			
	Pressure Relief Valve 50#	30-0379					1	1	
	Pressure Relief Valve 50#	13-0002							1
	Pressure Relief Valve 125#	30-0364	1	1	1	1	1	1	1
18	Tridicator 0-100 psi (PRV 30 - 50 psi)	13-0308	1	1	1	1	1	1	1
	Tridicator 0-230 psi (PRV 60 - 160 psi)	13-0305	1	1	1	1	1	1	1
19	Turbo Pilot Orifice NG	10-0142-001	1						
		10-0142-002		1	1	1	1	1	1
	Turbo Pilot Orifice LP	10-0143-001	1	1	1	1	1	1	1
20	Blocked Flue Switch (.4"-4") w.c.	11-0420	1	1	1	1	1	1	1
	Air Intake Switch (.2") w.c.	11-0416	1	1	1	1	1	1	1
21	Cabinet Pressure Switch (.4"-4") w.c.	11-0420	1	1	1	1	1	1	1
	Pressure Switch Mounting Ring	57-0732	1	1	1	1	1	1	1
22	Pilot Ball Valve	11-0395	1	1	1	1	1	1	1
NS	CSD-1 Leak Test Valve	11-0031	1	1	1	1	1	1	1
23	Turbo Pilot Spark Rod Assembly NG (not compatible w/burners prior to 0614)	70-4303-001	1						
		70-4303-002		1	1				
		70-4303-003				1	1	1	1
	Turbo Pilot Spark Rod Assembly LP (not compatible w/burners prior to 0614)	70-4304-001	1	1	1				
		70-4304-002				1	1	1	1
23a	Electrode (Turbo Pilot)	16-0338	1	1	1				
	Electrode (Turbo Pilot)	16-0335				1	1	1	1
23b	Turbo Pilot Gasket	06-0055	1	1	1				
		06-0056				1	1	1	1
23c	View Port Assembly	70-2205	1	1	1	1	1	1	1
	View Port Glass	20-0006	1	1	1	1	1	1	1
23d	Mini Peeper, C7027A	16-0009	1	1	1	1	1	1	1
24	Ignition Cable	44-0063	1	1	1	1	1	1	1
NS	Pressure Switch Tubing (ft)	06-0051	2	2	2	2	2	2	2
26	Pilot Valve	11-0079	1	1	1	1	1	1	1
27	Flow Switch	14-0203	1	1	1	1	1	1	1
	Flow Switch (Outdoor)	14-0205	1	1	1	1	1	1	1
	Flow Switch (Potter)	14-0201	1	1	1	1	1	1	1
	Flow Switch (Outdoor Potter)	14-0202	1	1	1	1	1	1	1
NS	3/4" PVC Foam Panel Gasket - Indoor Assembly (per ft/per roll 50')	06-0151	75	75	75	75	75	75	75
NS	1" PVC Foam Gasket - Outdoor Assembly (per ft/ per roll 50')	06-0152	50	50	50	50	50	50	50
NS	Red Silicone Combustion Chamber Gasket (per roll 50')	06-0146	50	50	50	50	50	50	50
30	(Outdoor) Jacket Gasket Material (per roll 50')	66-0102	100	100	100	100	100	100	100
31	Burner Gasket (Must order as a kit)	21-2012	1	1	1				
		21-2013				1	1	1	1

FUTERA II INSTALLATION AND OPERATION INSTRUCTIONS

Futera II Model Size with Item Quantities Below										
Ref #	Name of Part	Part #	500	750	1000	1250	1500	1750	1950	
32	Flame Safeguard, RM7897C (Verify Component Model)	75-0404-001	1	1	1	1	1	1	1	
	Flame Safeguard, RM7895C (Verify Component Model)	75-0403-001	1	1	1	1	1	1	1	
NS	Keyboard Display Module, S7800A	16-0067-001	1	1	1	1	1	1	1	
NS	UV Amplifier, R7849A	16-0006	1	1	1	1	1	1	1	
33	High Limit, L4008E, (FW)	14-0105	1	1	1	1	1	1	1	
	High Limit, L4008E, (FB)	14-0112	1	1	1	1	1	1	1	
34	Operator, Jumo	16-0069-001	1	1	1	1	1	1	1	
NS	Temperature Probe Sensor	16-0026	1	1	1	1	1	1	1	
37	Top Panel View Port Frame & Glass	20-0032	1	1	1	1	1	1	1	
38	Heat Exchanger "V" Baffle Strap	03-1619	2	2	2					
		03-1620				2	2	2	2	
44	Complete Burner Assembly, w/Turbo Pilot, NG	70-4301-001	1							
		70-4301-002		1						
		70-4301-003			1					
		70-4301-004				1				
		70-4301-005					1			
		70-4301-006						1		
		70-4031-007							1	
	Complete Burner Assembly, w/Turbo Pilot, LP	70-4302-001	1							
		70-4302-002		1						
		70-4302-003			1					
		70-4302-004				1				
		70-4302-005					1			
		70-4302-006						1		
		70-4302-007							1	
45	On/Off Safety Gas Valve, L8214G, 1", 120V	11-0371	1	1						
	On/Off Safety Gas Valve, L8214G, 1 1/4", 120V	11-0364			1	1	1	1 (LP)	1 (LP)	
	On/Off Safety Gas Valve, L8214G, 1 1/2", 120V	11-0365						1	1	
46	2 Stage Gas Valve, V4944B, 1", 120V	11-0166	1	1						
	2 Stage Gas Valve, V4944B, 1 1/4", 120V	11-0167			1	1	1			
	2 Stage Gas Valve, V4944B, 1 1/2", 120V	11-0168						1	1	
	2 Stage Gas Valve, V4944L, 1", 120V	11-0180	1	1						
	2 Stage Gas Valve, V4944L, 1 1/4", 120V	11-0170			1	1	1	1	1	
47	Main Gas Orifice, NG	10-0051	1							
		10-0052		1						
		10-0053			1					
		10-0054				1				
		10-0055					1			
		10-0056						1		
		10-0057							1	
	Main Gas Orifice, LP	10-0058	1							
		10-0059		1						
		10-0060			1					
		10-0061				1				
		10-0062					1			
		10-0063						1		
		10-0064							1	
48	"A" Valve, 1"	11-0465	1	1						
	"A" Valve, 1 1/4"	11-0466			1	1	1	1 (LP)	1 (LP)	
	"A" Valve, 1 1/2"	11-0467						1	1	
49	Firing Valve, 1"	11-0456	1	1						
	Firing Valve, 1 1/4"	11-0457			1	1	1			
	Firing Valve, 1 1/2"	11-0458						1	1	
8	Inlet Adapter (Flanged)	01-0044GL	1	1	1					
		01-0045GL				1	1	1	1	
	Outlet Adapter (Flanged)	01-0046GL	1	1	1					
		01-0047GL				1	1	1	1	
	Outlet Adapter (Threaded)	01-0042	1	1	1					
		01-0043				1	1	1	1	
Inlet/Outlet Header Gasket (Must order as a kit)	21-2012	1	1	1						
		21-2013				1	1	1	1	

FUTERA II INSTALLATION AND OPERATION INSTRUCTIONS

Futera II Model Size with Item Quantities Below										
Ref #	Name of Part	Part #	500	750	1000	1250	1500	1750	1950	
51	Heat Exchanger Assembly (Copper) Cast Iron (prior to 2009 must replace with bronze headers or change combustion chamber top panel to adapt to cast iron)	70-2515R	1							
		70-2516R		1						
		70-2517R			1					
		70-2518R				1				
		70-2519R					1			
		70-2520R						1		
			70-2521R						1	
	Heat Exchanger Assembly (Copper) Bronze	70-2186R	1							
		70-2187R		1						
		70-2188R			1					
		70-2189R				1				
		70-2190R					1			
		70-2191R							1	
			70-2192R							1
	Individual copper/cupronickel tube (available for field repair) model and serial number required. Call for pricing									
		Tube Expansion Tool	30-0761	1	1	1	1	1	1	1
		Heat Exchanger Assembly (Cupronickel) Cast Iron (prior to 2009 must replace with bronze headers or change combustion chamber top panel to adapt to cast iron)	70-2522R	1						
			70-2523R		1					
			70-2524R			1				
			70-2525R				1			
			70-2526R					1		
70-2527R									1	
		70-2528R							1	
	Heat Exchanger Assembly (Cupronickel) Bronze	70-2193R	1							
		70-2194R		1						
		70-2195R			1					
		70-2196R				1				
		70-2197R					1			
		70-2198R							1	
		70-2199R							1	
52	Heat Exchanger "V" Baffle	03-1612	20							
		03-1613		20						
		03-1614			20					
		03-1615				28				
		03-1616					28			
		03-1617						28		
		03-1618							28	
53	High Limit Well, 3/8 x 3	13-0104	2	2	2	2	2	2	2	
57	Air Filter	09-0497	1	1	1					
		09-0498				1	1			
		09-0499						1	1	
NS	FII Overlay	82-0196	1	1	1	1	1	1	1	
NS	Clear Silicone Sealant	66-0151	1	1	1	1	1	1	1	
NS	Silicone Tubing	06-0051	2	2	2	2	2	2	2	
NS	Vent Termination Hood 8"	09-0113	1							
	Vent Termination Hood 10"	09-0115		1	1					
	Vent Termination Hood 12"	09-0116				1	1			
	Vent Termination Hood 14"	09-0141						1	1	
NS	Air Intake Hood 10"	09-0104	1	1	1					
	Air Intake Hood 12"	09-0105				1	1			
	Air Intake Hood 14"	09-0106						1	1	
NS	Barometric Damper 8"	09-0404	1							
	Barometric Damper 10"	09-0403		1	1					
	Barometric Damper 12"	09-0401				1	1			
	Barometric Damper 14"	09-0402						1	1	
NS	120 Volt Freeze Protection Damper Motor Assembly	09-0428	1	1	1	1	1	1	1	



FUTERA II START UP SHEET

Date of Start Up: _____

RBI Ref. #: _____

Serial # ('s): _____ Boiler #1 _____ Model# _____
 _____ Boiler #2 _____
 _____ Boiler #3 _____
 _____ Boiler #4 _____
 _____ Boiler #5 _____

The above information will be used to identify each boiler in the system. You should make every attempt to affix the boiler number as noted here to the boiler physically.

START UP PROCEDURE AND DATA

STEP	DESCRIPTION	Readings Or Checks By Boiler Number				
		1	2	3	4	5
1	No leaks, valves open, pump running, exchanger full					
2	Gas lines purged, no leaks, no missing test plugs					
3	Manometer installed in test port upstream of firing valve					
4	Manometer installed to air box pressure tap					
5	Wiring checked and verified with supplied diagram					
6	All terminals identified properly and tight					
7	Fan (no gas): Verify no air leaks through outer cabinet					
8	With fan running: Record air box pressure "WC"					
9	With fan running: Record back pressure "WC"					
10	Vent configuration (HOR: horizontal VER: vertical)					
11	Equivalent vent length (each fitting is 10' equivalent)					
12	Breaching size:					
13	Barometric installed/location:					
14	Through wall venting with factory supplied termination:					
15	Pilot adjusted to within 1 turn of max (natural gas only)					
16	Spark is strong and continuous w/o gas:					
17	Pilot fires-advances to main several times (main gas off)					
18	Voltage:					
19	Manifold pressure "WC" (see tag on boiler) High Fire					
20	Manifold pressure "WC" (see tag on boiler) Low Fire					
21	O ₂ Lo Fire%					
22	O ₂ Hi Fire %					
23	CO ₂ Lo Fire %					
24	CO ₂ Hi Fire %					
25	CO Lo Fire PPM					
26	CO Hi Fire PPM					
27	Efficiency Lo Fire %					
28	Efficiency Hi Fire %					
29	Inlet Temp (F)					
30	Outlet Temp (F)					
31	Temp. rise across the exchanger (don't exceed 35°F, 19.4°C)					

SAFETY CHECKS AND ADJUSTMENTS

STEP	DESCRIPTION	Readings Or Checks By Boiler Number				
		1	2	3	4	5
1	Low water cut off					
2	Low gas pressure					
3	High gas pressure					
4	Operator okay and set @:					
5	High limit okay and set @:					
6	Blocked flue switch drops out at ("WC"):					
7	Flame fail time:					
8	With fan running: Record air box pressure "WC"					
9	With fan running: Record back pressure "WC"					

COMMISSIONING THE UNIT

STEP	DESCRIPTION	Readings Or Checks By Boiler Number				
		1	2	3	4	5
1	Remove manometers and replace plugs					
2	Complete this start up form for rep					
3	Fill out factory start up form (w/boiler)					
4	Correct each boiler's settings sticker:					
5	Replace all covers (no air leaks):					
6	All valves opened and adjusted:					
7	Boiler pump is running					
8	Final operator setting:					
9	Final high limit setting:					
10	Boiler left in operation:					
11	Boiler to require return visit:					
12	End user instructed on operation:					
13	Contractor instructed on operation:					
14						
15						
16						

Start up report and procedure completed by: (please print) _____

From (company name) _____

Phone #: _____

AUTHORIZED TECH'S SIGNATURE: _____

Date: _____

Notes/Comments: _____



FUTERA II START UP CHECK LIST

The following items must be field verified as complete prior to the scheduling of factory authorized start up.

- | | | |
|--|------------------------------|-----------------------------|
| 1. All electrical is installed and checked: | <input type="checkbox"/> Yes | <input type="checkbox"/> No |
| 2. All water connections are made: | <input type="checkbox"/> Yes | <input type="checkbox"/> No |
| 3. System is flooded and pressure tested: | <input type="checkbox"/> Yes | <input type="checkbox"/> No |
| 4. All pumps (primary or secondary) are running: | <input type="checkbox"/> Yes | <input type="checkbox"/> No |
| 5. Flow switches installed and adjusted: | <input type="checkbox"/> Yes | <input type="checkbox"/> No |
| 6. Drain valve installed on outlet prior to isolation (boiler only): | <input type="checkbox"/> Yes | <input type="checkbox"/> No |
| 7. T/P gauge installed on outlet prior to isolation (boiler only): | <input type="checkbox"/> Yes | <input type="checkbox"/> No |
| 8. Low water cut off installed and wired: | <input type="checkbox"/> Yes | <input type="checkbox"/> No |
| 9. Lead/lag/external controls installed and tested: | <input type="checkbox"/> Yes | <input type="checkbox"/> No |
| 10. All gas connections are complete: | <input type="checkbox"/> Yes | <input type="checkbox"/> No |
| 11. Gas pressure verified between 5" and 14" WC | <input type="checkbox"/> Yes | <input type="checkbox"/> No |
| 12. Gas lines purged and tested for leaks: | <input type="checkbox"/> Yes | <input type="checkbox"/> No |
| 13. All stacks/vents connected per spec: | <input type="checkbox"/> Yes | <input type="checkbox"/> No |
| 14. Air inlet duct work and related items installed: | <input type="checkbox"/> Yes | <input type="checkbox"/> No |
| 15. All boiler related equipment operational: | <input type="checkbox"/> Yes | <input type="checkbox"/> No |
| 16. _____ | <input type="checkbox"/> Yes | <input type="checkbox"/> No |
| 17. _____ | <input type="checkbox"/> Yes | <input type="checkbox"/> No |
| 18. _____ | <input type="checkbox"/> Yes | <input type="checkbox"/> No |
| 19. _____ | <input type="checkbox"/> Yes | <input type="checkbox"/> No |
| 20. _____ | <input type="checkbox"/> Yes | <input type="checkbox"/> No |

Finned Copper Tube Boilers/Water Heaters Industrial, Commercial and Other Non-Residential Use

LIMITED WARRANTY

The specific company or business unit that manufactured the products purchased ("Manufacturer") warrants exclusively to the original owner at the original installation site (hereinafter "Owner") that the heat exchanger provided in Finned Copper Tube Boilers (the "Boiler Product") and Finned Copper Tube Water Heaters ("Water Heater Product") (collectively "Products") to be used exclusively for Industrial, Commercial and Other Non-Residential Use modulating water boiler ("Water Heater Product") (collectively "Products") will be free from defects in material and workmanship for the periods set forth below in the Warranty Effective Periods A, B, C and D. All warranty claims are subject to, and contingent upon, Owner following the terms of the Warranty claim service procedure set forth below as well as the specific Product requirements set forth in the Warranty Effective periods A, B C., and D. below. Failure to do shall void the warranty.

Warranty claim service procedure

1. Owner must first obtain a Return Material Authorization ("RMA") from the manufacturer before returning any Products.
2. Products must be returned to the Manufacturer at Owner's expense, including packaging, transportation and any applicable VAT and import duty costs, and risk of loss or damage to the manufacturer's factory set forth when obtaining the RMA.
3. Manufacturer shall evaluate the returned Products purported to be defective due to defects in material or Manufacturer's workmanship and will determine in its reasonable and sole discretion if indeed such defects have occurred.
4. If indeed the Product is determined to be defective due to defects in material or Manufacturer's workmanship, Manufacturer shall either repair or replace, at its option, the Product.
5. Repaired or replacement Products shall be returned to Owner on an EXW (Ex Works basis, Incoterms 2020 or current version) at Owner's expense and risk.
6. The repaired or replacement Products returned to Owner shall be warranted only for the remainder of the original warranty effective period and the repair or replacement of Product shall not extend the effective period of the original warranty on the Product.

Warranty Effective Periods/Product Requirements

A. One-Year Warranty

The "Manufacturer" warrants to the Owner that the parts comprising the RBI Finned Copper Tube Boiler/Water Heater ("Product") will be free from defects in material and workmanship for one (1) year from the date of installation or eighteen (18) months from the date of shipment from the factory whichever comes first except where otherwise noted herein below.

B. Five-Year Warranty

The manufacturer further warrants to the Owner that the Copper Heat Exchanger provided in the Water Heater Products will be free from condensate corrosion and in material and workmanship for a period of five years (non prorated) from the date of installation or sixty-six (66) months from the date of shipment from the factory, whichever occurs first contingent upon the following: This Water Heater Product is designed to operate scale free, maintaining the pH between 5 and 9, maintaining a water hardness between 8 and 18 grains per gallon with a level of dissolved solids not exceeding 350 ppm. Water having a hardness of less than 8 grains can cause excessive corrosion of the heat exchanger. Water that has a hardness greater than 18 grains per gallon and/or a level of dissolved solids exceeding 350 ppm will require a larger circulating pump and a cupro-nickel heat exchanger. Water hardness greater than 24 grains per gallon will require a water softener system. (See Installation Instructions for proper pump and heat exchanger performance.) Failure to follow any of these requirements will void the warranty.

C. Ten-Year Warranty

The manufacturer further warrants to the Owner that the Copper Heat Exchanger provided in the Boiler Products will be free from defects from condensate corrosion and in material and workmanship for a period of **either** ten (10) years (non prorated) from the date of installation or one hundred twenty-six (126) months from the date of shipment from the factory, whichever occurs first provided that (i) Suspended solids such as magnetite, Iron Oxides were flushed from the system prior to commissioning the boiler(s), (ii). The system fill water did not at any time contain more than 500 ppm of dissolved solids, did not contain less than 150 ppm chloride concentration and was not greater than 200 ppm hardness, (iii) the PH level must be, and have been, at all times, within 5-9 range, (iv) the system has been protected by the addition of a corrosion inhibitor where required by either the chemical supplier's or manufacturer's instructions, (v) A minimum system pressure of (20 psig, 138, kPa) has been maintained at boiler operating conditions - (30 psig, 207 kPa is required for glycol systems) and (vi) for systems that require glycol for freeze protection, the use of a glycol/water mix that prevents foaming is mandatory because air entrapped within foam significantly decreases heat transfer and can result in damage to the heat exchanger. Failure to follow any of these requirements will void the warranty.

D. Twenty-One Year Thermal Shock Warranty

The manufacturer further warrants to the Owner that the Heat Exchangers in the Products will be warranted for twenty-one (21) years against thermal shock when installed in a closed loop hot water system. This warranty does not cover damage due to corrosion, scaling, sooting or to improper installation practices as set forth in the Exclusions to the Limited Warranty below. The inlet / outlet temperature differential across the boiler heat exchanger must not exceed 60 degrees F. Failure to follow these guidelines will void the warranty.

Exclusions to This Limited Warranty all exclusions will be determined in the sole discretion of Manufacturer:

- a. Any expenses, including manufacturer's on-site labor or material, incurred during the removal or reinstallation of the product or replacement parts thereof all of which are the responsibility of the Owner.
- b. Products that have been subjected to misuse or neglect, have been accidentally or intentionally damaged, has not been installed, maintained or operated in accordance with the manufacturer's furnished written instructions or manuals, or has been altered or modified in anyway by any person other than those authorized in writing by the Manufacturer to do so. Chemical corrosion from corrosive chemicals (freon, dry cleaning chemicals, degreasing liquids, chlorine or any chemicals that produce hydrochloric acid) that may be present in the boiler room can rapidly destroy the heating equipment and void the warranty.
- c. Products in copper fin boilers operated with a return water temperature less than 110°F, 43°C atmospheric combustion, (125°F, 52°C fan assist combustion - Dominator/LCD/Futera II), (140°F, 60°C fan assist combustion Futera III/Futera XLF). If a lower temperature is required, an external bypass should be installed to prevent condensation (bypass and valve arrangement included on the Futera Fusion Series). The manufacturer's warranty does not cover damage done by condensation.
- d. Products that were not properly installed, maintained (serviced annually) or operated by a qualified contractor in accordance with the Manufacturer's furnished written instructions, or meet the good practice as defined by the industry's accepted authority, or were altered or modified in anyway by any person other than those authorized in writing by the Manufacturer to do so.
- e. Burners, jackets, controls and other auxiliary equipment furnished by the manufacturer, but manufactured by others. Any warranties for such items shall be limited to those warranties offered by the original equipment manufacturer.
- f. Damage associated with or caused by the installation of the Products regardless of whether the installer, provided by the Owner, is considered, or was authorized by Manufacturer, to be a qualified contractor, to perform the installation. The installation contractor is solely and exclusively responsible to the Owner for its own work and the results thereof.
- g. Lime build-up in the heat exchanger tubes that is caused by excessive water hardness
- h. Pitting and erosion on the inside of the heat exchanger tubes caused by high water velocity through the tubes
- i. Products installed outside the continental United States or Canada.

THIS LIMITED WARRANTY IS THE EXCLUSIVE WARRANTY TO THE FINNED COPPER TUBE BOILERS AND FINNED COPER TUBE WATER HEATERS AND IS IN LIEU OF ALL OTHER WARRANTIES, EXPRESS OR IMPLIED, OF ANY KIND AND SUPERSEDES ALL OTHER WARRANTIES, INCLUDING THOSE CONTAINED IN OTHER DOCUMENTS WHICH MIGHT HAVE BEEN INCLUDED WITH THE PRODUCTS OR BOILERS AT THE TIME OF SHIPMENT. THE REMEDIES UNDER THIS WARRANTY ARE EXCLUSIVE TO THE ORIGINAL OWNER ("OWNER") AT THE ORIGINAL PLACE OF INSTALLATION AND MANUFACTURER NEITHER ASSUMES NOR AUTHORIZES ANYONE TO OFFER OR ASSUME FOR IT ANY OTHER OBLIGATIONS. THIS WARRANTY GIVES OWNER SPECIFIC LEGAL RIGHTS HOWEVER IN NO EVENT SHALL MANUFACTURER BE LIABLE FOR ANY DIRECT DAMAGES THAT EXCEED THE ORIGINAL SALE PRICE OF THE PRODUCTS SOLD TO OWNER THAT ARE FOUND TO BE DEFECTIVE, SPECIAL, INDIRECT, CONSEQUENTIAL, PUNITIVE OR INCIDENTAL DAMAGES OF ANY KIND, OR ON-SITE LABOR, EXPENSES OF ANY KIND, LOST PROFITS, LOST OPPORTUNITIES, OR SIMILAR DAMAGES OF ANY KIND; AND REGARDLESS OF THE LEGAL THEORY OR CAUSES OF ACTION BY WHICH CLAIMS FOR ANY SUCH DAMAGES AS SET FORTH IN THE ENTIRETY OF THE DOCUMENTS RELATED TO THE SALE OF THE BOILER CONTRACT ARE ADVANCED, WHETHER OR NOT MANUFACTURER HAS BEEN ADVISED OF THE POSSIBILITY OF ANY SUCH DAMAGES.



260 North Elm Street
Westfield, MA 01085
Phone: (833) 265-5371

7555 Tranmere Drive
Mississauga, Ontario L5S 1L4 Canada
Phone: (905) 670-5888

www.rbiwaterheaters.com

