

Randell Manufacturing, Inc.

OWNERS MANUAL

This manual provides information on installation, operating, maintenance, troubleshooting & replacement parts for

40000 SERIES
MODELS 4030GA, 40026



NOTIFY CARRIER OF DAMAGE AT ONCE.

It is the responsibility of the consignee to inspect the container upon receipt of same and to determine the possibility of any damage, including concealed damage. Randell suggests that if you are suspicious of damage to make a notation on the delivery receipt. It will be the responsibility of the consignee to file a claim with the carrier. We recommend that you do so at once.



520 S. Coldwater Road Weidman, MI 48893-9683

Phone 1-800-621-8560 Fax 1-800-634-5369 www.randell.com

TABLE OF CONTENTS

Page 2	Congratulations
Page 3	Factory Correspondence
Page 4	Serial Number Location
Page 5	Unit Specifications
Page 6	Randell Limited Warranty
Page 9	Unit Installation
Page 12	Unit Operation
Page 12	Preventative Maintenance
Page 14	Troubleshooting
Page 15	Part Diagrams

Congratulations on your recent purchase of Randell food service equipment, and welcome to the growing family of satisfied Randell customers.

Our reputation for superior products is the result of consistent quality craftsmanship. From the earliest stages of product design, to successive steps in fabrication and assembly, rigid standards of excellence are maintained by our staff of designers, engineers, and skilled employees.

Only the finest heavy-duty materials and parts are used in the production of Randell brand equipment. This means that each unit, given proper maintenance, will provide years of trouble free service to its owner.

In addition, all Randell food service equipment is backed by one of the best warranties in the food service industry and by our professional staff of service technicians.

Retain this manual for future reference.

Notice: Due to a continuous program of product improvement, Randell Manufacturing reserves the right to make changes in design and specifications without prior notice.

Notice: Please read the entire manual carefully before installation.
If certain recommended procedures are not followed, warranty claims will be denied.

Model Number _____
Serial Number _____
Installation Date _____

**Randell Manufacturing
Service and Parts
Hot Line
1-800-621-8560**

LANDELL MANUFACTURING
SERIAL NUMBER LOCATIONS
FOR THE
4030GA & 40026SSA



This is a sample of a serial number tag.

The serial number tag is located on the outside cabinet.

Unit Specifications

For

4030GA & 40026SSA

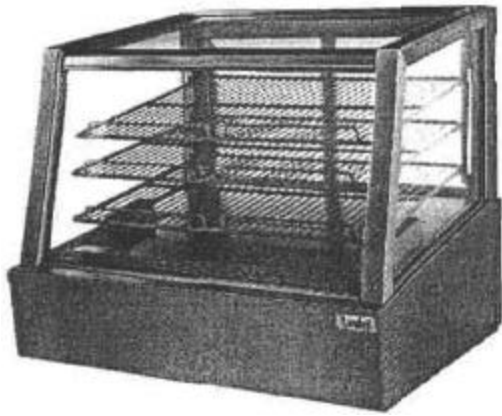

4030GA



40026SSA

Model	L	D	H	Style	HP	Volt	AMP	NEMA	Ship Wt
4030GA	30"	27"	28"	Counter top	1/3	115/60/1	7	5-15P	240
40026A	26"	24"	39"	Pass-thru	1/4	115/60/1	5	5-15P	240
40026SSA	26"	24"	39"	Single serve	1/4	115/60/1	5	5-15P	240

Randell Manufacturing, Inc.

Warranty Policies

Parts Warranty

Randell warrants all component parts of manufactured new equipment to be free of defects in material or workmanship, and that the equipment meets or exceeds reasonable industry standards of performance for a period of one year from the date of shipment from any Randell factory, assembly plant or warehouse facility.

Note: Warranties are effective from date of shipment, with a thirty day window to allow for shipment, installation and set up. In the event equipment was shipped to a site other than the final installation site, Randell will warranty for a period of three months following installation, with proof of starting date, up to a maximum of eighteen months from date of purchase.

Component parts warranty does not cover glass breakage or gasket replacement. Randell covers all shipping cost related to component part warranty sent at regular ground rates (UPS, USPS). **Freight or postage incurred for any express or specialty methods of shipping is the responsibility of the customer.**

Labor Coverage

In the unlikely event a Randell manufactured unit fails due to defects in materials or workmanship within the first ninety days, Randell agrees to pay reasonable labor incurred. During the first ninety days work authorizations are not required for in warranty repairs. However, repair times are limited to certain flex rate schedules and hours will be deducted from service invoices if they exceed allowed times without prior approval and a work authorization number. Warranties are effective from date of shipment, with a 30 day window to allow for shipment, installation and setup. Where equipment is shipped to any site other than final installation Randell will honor the labor warranty for a period of ninety days following installation with proof of starting date, up to a maximum of nine months from date of purchase. Travel time is limited to one hour each direction or two hours per invoice. **Any travel time exceeding two hours will be the responsibility of the customer.**

Note: Temperature adjustments are not covered under warranty, due to the wide range of ambient conditions.

Five Year Extended Compressor Warranty

United States installations only:

Randell will pay for the replacement compressor only. Freight, labor, refrigerant, handling and all other miscellaneous charges are the responsibility of the customer. Randell will fulfill its warranty obligation by using one of the four methods provided below, which will be selected by the Randell in house service technician:

1. Provide reimbursement to servicing customer for the cost of the locally obtained replacement compressor in exchange for the return of the defective compressor returned to Randell freight prepaid. Randell does limit the amount of reimbursement allowed and does require a copy of the local supply house bill for replacement compressor.

Customer should not pay servicing agent up front for compressor.

2. Provide repair at the manufacturing facility by requiring that the defective unit be sent back to Randell freight prepaid. Perform repair at the expense of Randell and ship the item back to job location freight collect.

3. Furnish a replacement compressor freight collect in exchange for the return of the defective compressor sent back freight prepaid.

4. Furnish complete condensing unit or replacement package freight collect in exchange for the return of the defective compressor sent back freight prepaid, (decisions based on whether or not to send complete condensing unit will be made by Randell in-house service technician).

Export Warranty

Our export warranties will cover all non-electrical parts for the period of one year from the date of shipment to be free of defects on material and workmanship. Electrical parts are also covered if ordered and operated on 60 Hz. Electrical components, ordered and operated on 50 Hz, are warranted for the first 90 days from shipment only. Service labor is covered for the first 90 days with authorization from factory prior to service. Warranty is automatically initiated 60 days from ship date. Inbound costs on any factory supplied items would be the responsibility of the customer. Adherence to recommended equipment maintenance procedures, according to the owner's manual provided with each unit, is required for this warranty to remain in effect, and can have a substantial effect on extending the service life of your equipment. Equipment abuse voids any warranty. Extended warranties are not available for parts, labor or compressors on units shipped outside the United States.

Freight Damage

Any and all freight damage that occurs to a Randell piece of equipment as a result of carrier handling is not considered warranty, and is not covered under warranty guidelines. Any freight damage incurred during shipping needs to have a freight claim filed by the receiver with the shipping carrier (note all damages on freight bill at time of delivery). Internal or concealed damage may fall under Randell's responsibility dependent upon the circumstances surrounding each specific incident and are at the discretion of the Randell in-house service technician.

Gasket Coverage

Randell does not cover gaskets under warranty. Gaskets are a maintenance type component that are subject to daily wear and tear and are the responsibility of the owner of the equipment. Because of the unlimited number of customer related circumstances that can cause gasket failure all gasket replacement issues are considered non-warranty. Randell recommends thorough cleaning of gaskets on a weekly basis with a mild dish soap and warm water. With proper care Randell gaskets can last up to two years, at which time we recommend replacement of all gaskets on the equipment for the best possible performance.

Notice: FOOD LOSS IS NOT COVERED UNDER WARRANTY

Unit Installation

A. Receiving Shipment

Upon arrival, examine the exterior of the shipping crate for signs of abuse. It is advisable that the shipping crate be partially removed, in order to examine the cabinet for any possible concealed damages which might have occurred during shipment. If no damages are evident, replace the crate in order to protect the unit during local delivery. If the unit is damaged, it should be noted on the delivery slip or bill of lading and signed to that effect. A claim must be filed immediately against the carrier indicating the extent and estimated cost of damage occurred.

B. Locating Your New Display Merchandiser

The following conditions should be considered when selecting a location for your unit:

1. Countertop load - The countertop on which the merchandiser will display rest must be free of vibration and suitably strong enough to support the combined weights of the units plus the maximum product load weight:

MODEL	ACTUAL NEEDED COUNTER CAPACITY
4030GA	426LBS.
40026A	407LBS.
40026SSA	407LBS.

2. Clearance - There must be a combined total of at least 10" clearance at the top of the unit.

3. Ventilation - The air cooled self contained display merchandiser requires a sufficient amount of cool clean air. Avoid placing the unit near heat generating equipment such as ovens, ranges, heaters, fryers, steam kettles, etc. and out of direct sunlight. Avoid locating the make table in an unheated room or where the room temperature may drop below 55° F or above 90° F.

C. Electrical Supply

The wiring should be done by a qualified electrician in accordance with local electrical codes. A properly wired, and grounded outlet will assure proper operation. Please consult the data plate attached to the compressor to ascertain the correct electrical requirements. Supply voltage and amperage requirements are located on the serial number tag.

Note: It is important that a voltage reading be made at the compressor motor electrical connections, while the unit is in operation, to verify that the correct voltage required by the compressor is being supplied. Low or high voltage can detrimentally affect operation and thereby void its warranty.

Note: It is important that your unit has its own dedicated line. Condensing units are designed to operate with a voltage fluctuation of plus or minus 10% of the voltage indicated on the unit data plate. Burn out of a condensing unit due to exceeding voltage limits will void the warranty.

D. Door Inspection

1. Check doors to ensure that they are sealing properly.
2. Check doors for proper alignment.
3. Check doors to ensure that they open and shut freely.

E. Installation Checklist

After the final location of the display merchandiser has been determined refer to the following checklist prior to start up:

1. Check all exposed refrigeration lines to ensure that they are not kinked, dented or rubbing together.
2. Check that condenser and evaporator fans rotate freely without striking any stationary members.
3. Unit must be properly leveled.
4. Plug unit in and turn on main power switch and/or cold control.
5. Refer to the front of this manual for serial number location. Please record this information in your manual on page 3 now. It will be necessary when ordering replacement parts or requesting warranty service.
6. Confirm that unit is holding temperature. Set controls to desired temperature for your particular ambient and altitude.
7. Allow your display merchandiser to operate for approximately 2 hours before putting in food. This allows interior to cool down to the correct storage temperature.

Note: All motors are oiled and sealed.

Figure A - Temperature control adjustments

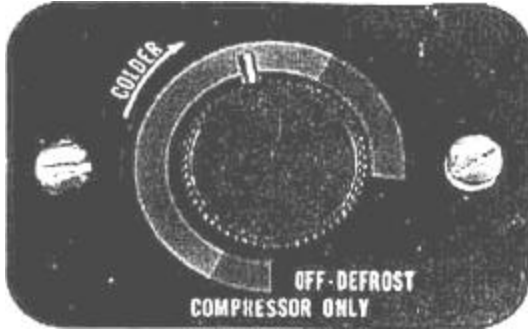

The control knob allows for temperature adjustments, with in the cabinet only. Turning the knob clockwise will result in increased cooling. Keep the arrow on the knob pointed within the green arc. Turning it clockwise beyond the green can result in freeze-up, while turning it counterclockwise beyond the green will shut the compressor off. If your cabinet temperature remains to warm and your temperature control is at the

maximum setting you may need to adjust the pressure control.

Your units pressure control should be set at the time of installation by a qualified installation contractor. If minor adjustments are needed at a later date, adjust control by turning the right adjusting screw clockwise (1/4 turn at a time) to a lower number for colder temperature and counterclockwise to a higher number for warmer temperature.

Note: Numbers are pounds of pressure not degrees F.

Note: Do not adjust the differential screw (Left screw).

Unit Operation

Your display merchandiser's temperature is adjusted by a cold control which for the 40026 is located on top of the unit and on the 4030GA is located directly behind the louvered panel on the access side of the merchandiser. It is important to keep the doors closed as much as possible. This is especially important in the summer and when ambient temperatures exceed 80° F. to help reduce the chance of condensation forming on the glass and to increase the efficiency of the merchandiser.

Note: Even though your display case was designed for heavy use, excessive door openings should be avoided, in order to maintain proper box temperature and eliminate the possibility of coil freeze up.

Preventive Maintenance

Randell strongly suggests a preventive maintenance program which would include the following **Monthly** procedures:

1. Cleaning of all condenser coils. Condenser coils are a critical component in the life of the compressor and must remain clean to assure proper air flow and heat transfer. Failure to maintain this heat transfer will affect unit performance and eventually destroy the compressor. Clean the condenser coils with coil cleaner and/or a vacuum cleaner and brush.

Note: Brush coil in direction of fins, normally vertically as to not damage or restrict air from passing through condenser.

2. Clean all fan blades, both on the condensing unit and the evaporator assembly.
3. Lubricate door hinges with lithium grease.
4. Clean and disinfect drain lines and evaporator pan with a solution of warm water and bleach.
5. Clean all gaskets on a weekly if not daily basis with a solution of warm water and a mild detergent to extend gasket life.

NOTE: DO NOT USE SHARP UTENSILS

Recommended cleaners for your stainless steel include the following:

JOB	CLEANING AGENT	COMMENTS
Routine cleaning	Soap, ammonia, detergent Medallion	Apply with a cloth or sponge
Fingerprints & smears	Arcal 20, Lac-O-Nu, Ecoshine	Provides a barrier film
Stubborn stains and discoloration	Cameo, Talc, Zud, First Impression	Rub in the direction of the polish lines
Grease, fatty acids, blood and burnt on foods	Easy-off, Degrease It, Oven Aid	Excellent removal on all finishes
Grease and oil	Any good commercial detergent	Apply with a sponge or cloth
Restoration/Passivation	Benefit and Super Sheen	Good idea monthly

Reference: Nickel Development Institute, DiverseyLever, Savin, Ecolab, NAFEM

Do not use steel pads, wire brushes, scrapers or chloride cleaners to clean your stainless steel.

CAUTION: DO NOT USE ABRASIVE CLEANING SOLVENTS, NEVER USE HYDROCHLORIC ACID (MURIATIC ACID) ON STAINLESS STEEL.

Proper maintenance of equipment is the ultimate necessity in preventing costly repairs. By evaluating each unit on a regular schedule you can often catch and repair minor problems before they completely disable the unit and become burdensome on your entire operation.

For more information on preventive maintenance consult your local service company or CFESA member. Most repair companies offer this service at very reasonable rates to allow you the time you need to run your business along with the peace of mind that all your equipment will last throughout its expected life. These services often offer guarantees as well as the flexibility in scheduling of maintenance for your convenience.

Randell believes strongly in the products it manufacturers and backs those products with one of the best warranties in the industry. We believe with the proper maintenance and use you will realize a profitable return on your investment and years of satisfied service.

Troubleshooting

PROBLEM	POSSIBLE CAUSE	REMEDY
A. Refrigerator not running	<ol style="list-style-type: none"> 1. Circuit breaker tripped. 2. Power cord unplugged 3. Thermostat turned off 4. Unknown 	<ol style="list-style-type: none"> 1. Reset 2. Plug in 3. Turn on 4. Call service agency
B. Condensing unit operates for long periods or runs continuously	<ol style="list-style-type: none"> 1. Excessive heat load placed in unit 2. Prolonged or too frequent door openings or door ajar 3. Gasket not sealing 4. Dirty condenser coil 5. Evaporator coil frozen 6. Unknown 	<ol style="list-style-type: none"> 1. Allow unit sufficient time to remove heat. 2. Make sure door is closed when not in use. 3. Adjust door or replace gasket. 4. Clean coil 5. Unplug unit, defrost coil then adjust cold control to warmer position 6. Call service agency
C. Unit is noisy	<ol style="list-style-type: none"> 1. Check for loose compressor mounts 2. Check fan motor mounts 3. Check fan blades for obstructions 4. Check all panels, louvers and covers 5. Unknown 	<ol style="list-style-type: none"> 1. Tighten if necessary 2. Tighten if necessary 3. Remove any obstructions. Tighten or adjust shrouds. 4. Tighten and isolate as needed 5. Call service agency
D. Temperature too high	<ol style="list-style-type: none"> 1. Check power cord and circuit breaker 2. Temperature control set too high 3. Dirty condenser coil 4. Evaporator coil froze 5. Unknown 	<ol style="list-style-type: none"> 1. Plug in cord or reset breaker 2. Adjust control 3. Clean coil 4. Unplug unit, defrost coil then adjust cold control to warmer position 5. Call service agency
E. Compressor runs but unit not cooling	<ol style="list-style-type: none"> 1. Fan blades have encountered an obstruction 2. Unknown 	<ol style="list-style-type: none"> 1. Check for obstruction and free fan blade 2. Call service agency
F. Product freezing	<ol style="list-style-type: none"> 1. Check thermostat 2. Unknown 	<ol style="list-style-type: none"> 1. Replace or turn up 2. Call service agency
G. Door will not close	<ol style="list-style-type: none"> 1. Check opening for obvious obstruction 2. Check self closing spring 3. Check for loose or worn hinges 	<ol style="list-style-type: none"> 1. Remove any obstruction 2. Adjust or replace spring. 3. Replace hinges
H. Unit leaks water	<ol style="list-style-type: none"> 1. Check for blockage in drain 2. Check for cracked drain pan 3. Check for level 4. Check for loose or disconnected drain hose 	<ol style="list-style-type: none"> 1. Clean evaporator pan and clear drain 2. Inspect and replace if necessary 3. Level unit 4. Tighten or reconnect hose

4030G		
ITEM	DESCRIPTION	RANDELL PART #
1	LEG, CHROME	HD LEG200
14	SHELF 20" X 25 1/2"	HDSHL185
15	SHELF BRACKET (9" LONG)	RP BRK4030
17	MAIN POWER CORD	ELWIR461
40	R.H. OUTSIDE DOOR 14" X 13 3/4"	HD DOR4030r
41	L.H. INSIDE DOOR 14" X 13 3/4"	HD DOR4030L
53	DOOR FRAME ASSEMBLY 27 3/4" X 15 3/4"A"	HD DOR4030
94	EVAPORATOR DIFFUSER (SS BOTTOM) 26" X 11"	RP DIF4030
102	LOUVER 29 3/4" X 9 3/8"	RP LVR4030
116	THERMOSTAT	HD CNT200
131	COMPRESSOR AE630AT/ AE4440Y	RF CMP020
134	START COMPONENTS	RF CMP333
136	CONDENSOR 10 1/4" X 8" X 3 1/8"	RFCOI115
137	CONDENSOR FAN MOTOR	EL MTR085
138	CONDENSOR FAN BLADE 6" 4 BLADE	RF FAN011
140	FILTER DRYER 1/4" LINE	RF FLT250A
141	CONDENSATE PAN W/CLAMP 11" X 5 1/2"	RP PAN4030
152	EVAPORATOR 20 1/2 X 3 X 4	RFCOI130
158	EVAPORATOR FAN MOTOR	EL MTR590
159	EVAPORATOR FAN BLADE	RF FAN005
161	EVAPORATOR FAN SHROUD	RP SHR4030
162	EVAPORATOR FAN BRACKET	RP BRK1050
205	SET OF LOUVER LOCATOR PINS (2 PIECE)	HD PIN2030
407	LEFT & RIGHT HAND GLASS	HD GLS095
407	TOP GLASS 27 1/4" X 19 3/8"	HDGLS146
407	FRONT GLASS 16 9/16" X 27 1/4"	HDGLS100
516	4X4 JUNCTION BOX W/T-STAT COVER	EL BOX042
901	PLASTIC RETURN VENT	PL VNT4030

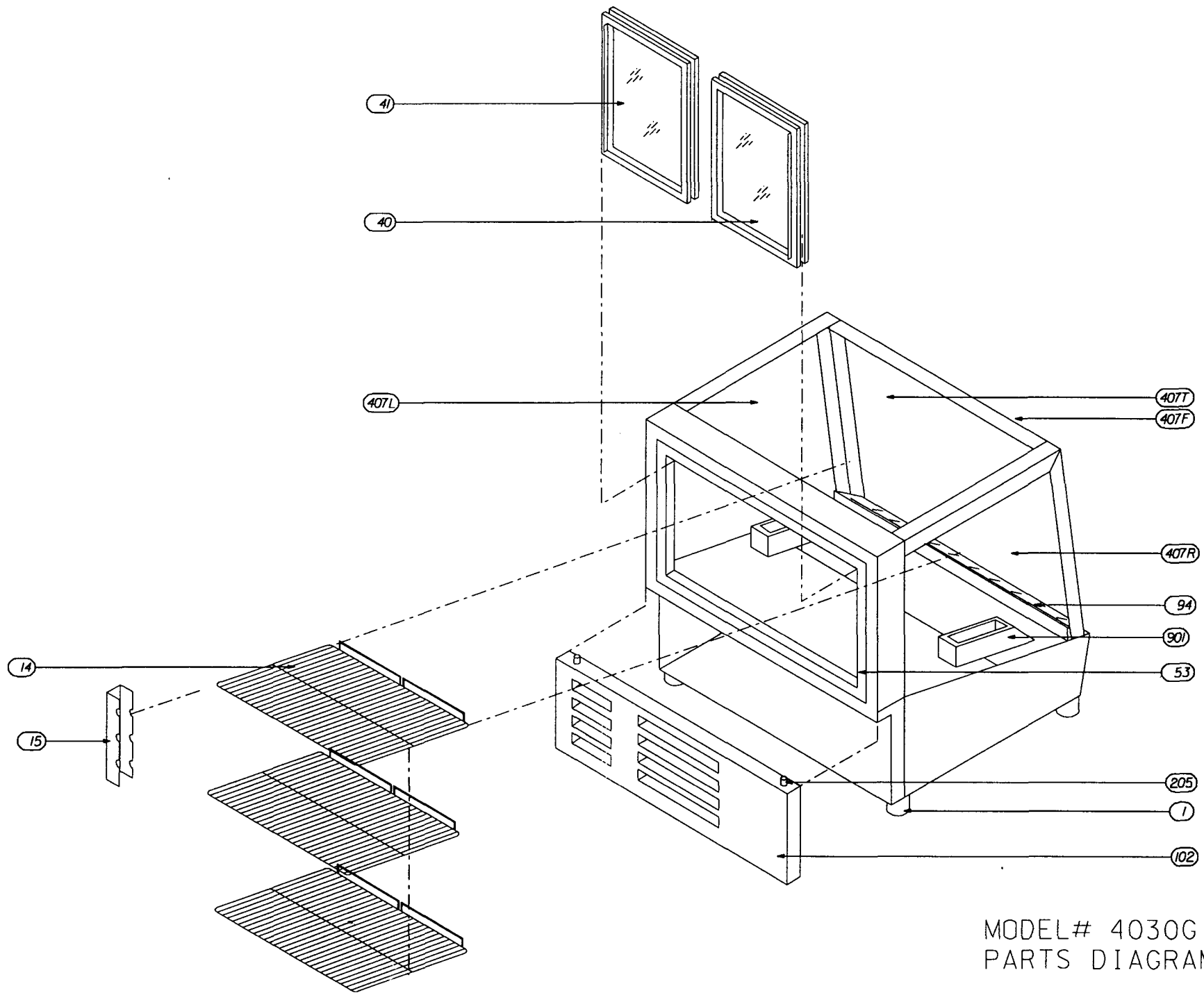

MODEL# 4030G
PARTS DIAGRAM

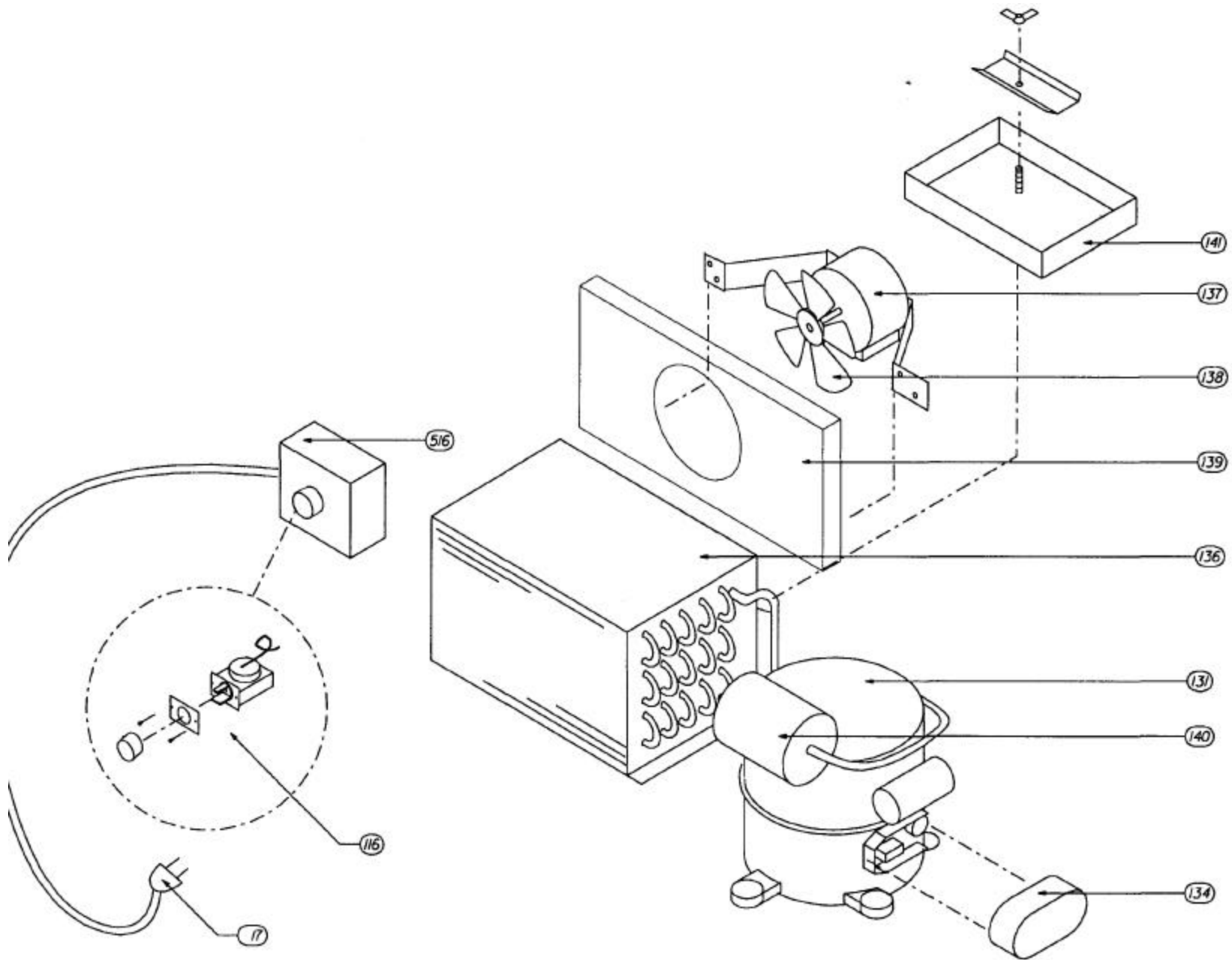

MODEL# 4030G
 PARTS DIAGRAM

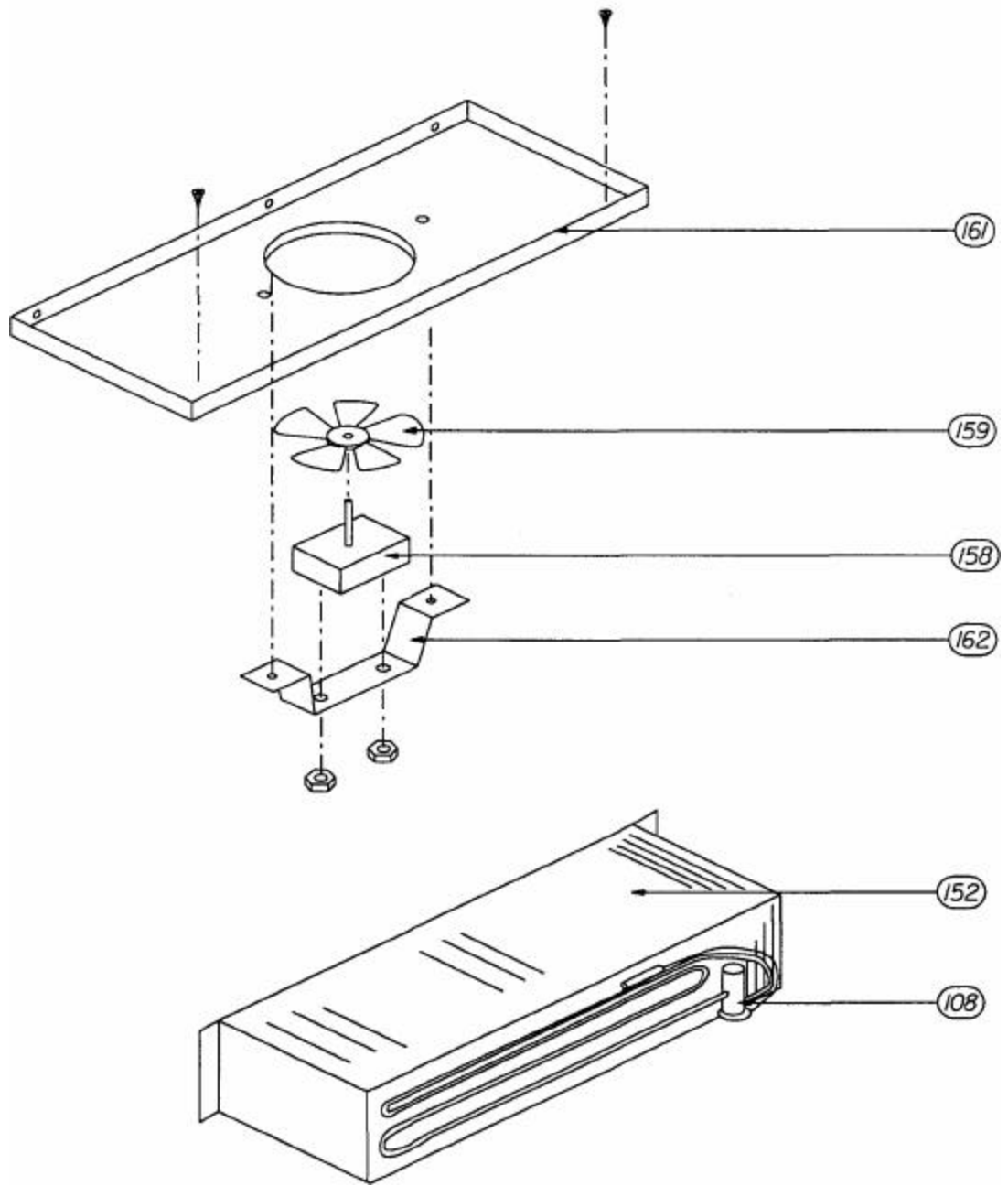

MODEL# 4030G PARTS
 DIAGRAM

	40026A	
ITEM	DESCRIPTION	PART#
1	6" ADJUSTABLE LEGS (SET OF 4)	HD LEG204
2	6" ADJUSTABLE LEGS	HD LEG200
13	PILASTERS W/ SCREWS 14"	RP PIL014
14	SHELF 19" X 21"	HD SHL055
17	POWER CORD 9'	EL WIR461
18	SHELF CLIPS SET OF 4	HD CLP5030
40	GLASS DOOR 25 3/4 X 22 3/4 LEFT OR RIGHT HAND	RP DOR4026
44	PIKE GASKET 25 1/2" X 22 1/2"	IN GSK4026
46	HINGE BRACKET SELF CLOSING R.H.	RP HNG426R
46A	HINGE BRACKET SELF CLOSING L.H.	RP HNG426L
47	DOOR HANDLE	RP HDL426
53	BREAKER STRIPS SET OF 4	PL STR426
54	DOOR FRAME HEATER 82" LONG	EL WIR 256
78	FLOURESCENT LIGHT FIXTURE 20"	RP LGT426F
79	BALLAST	ELBLS100
92	ALUMINIZED PAINTED LID FOR UNIT 18" X 25 3/4"	RP LID 426
94	LIGHT PANEL 11 1/2 X 26 COMPLETE W/FIXTURE	RP LGT426
102	LOUVER 26" X 11"	RP LVR426
109	COMPRESSOR POWER CORD MALE	EL WIR469
110	COMPRESSOR POWER CORD FEMALE	EL WIR470
112	CAP TUBE W/STRAINER (.036 DIA. @ 56")	RF CAP036
116	THERMOSTAT	HD CNT200
117	DIAL THERMOMETER	HD THR200
130	CONDENSING UNIT R134A	RF CON333
131	COMPRESSOR AE4440Y	RF CMP020
134	START COMPONENTS	RF STR333
136	CONDENSOR 6" X 10" X 2 3/4"	RF COI026
137	CONDENSER FAN MOTOR	RF FAN001
138	CONDENSER FAN BLADE	RF FAN333A
141	CONDENSATE PAN W/CLAMP 10" X 5"	RP PAN426

40026A		
ITEM	DESCRIPTION	PART#
151	EVAPORATOR MOUNTING BRACKET	RP BRK426
152	EVAPORATOR COIL 10 1/4" X 6" X 3 1/2"	RF COI115
153	EVAPORATOR DRIP PAN 5" X 12 1/4"	RP PAN427
155	BOX COVER	EL CVR426
158	EVAPORATOR FAN MOTOR	EL MTR590
159	EVAPORATOR FAN BLADE	RF FAN005
162	FAN MOUNTING BRACKET 12 3/4"	RP BRK427
407	PLEXI-GLASS LIGHT PANNEL 26" X 9 3/4"	RP PNL426
407	GLASS SEE THRU 25 1/4" X 24"	HD GLS144
511	TOGGLE SWITCH	EL SWT120
516	BOX FOR POWER SWITCH	EL BOX427
580	FLOURESCENT LIGHT BULB 17" 15 WATT	EL TUB150
719	EVAPORATOR DIFFUSER PLATE	RP DIF426
750	EVAPORATOR AIR SUPPLY GUARD	RP GRD426

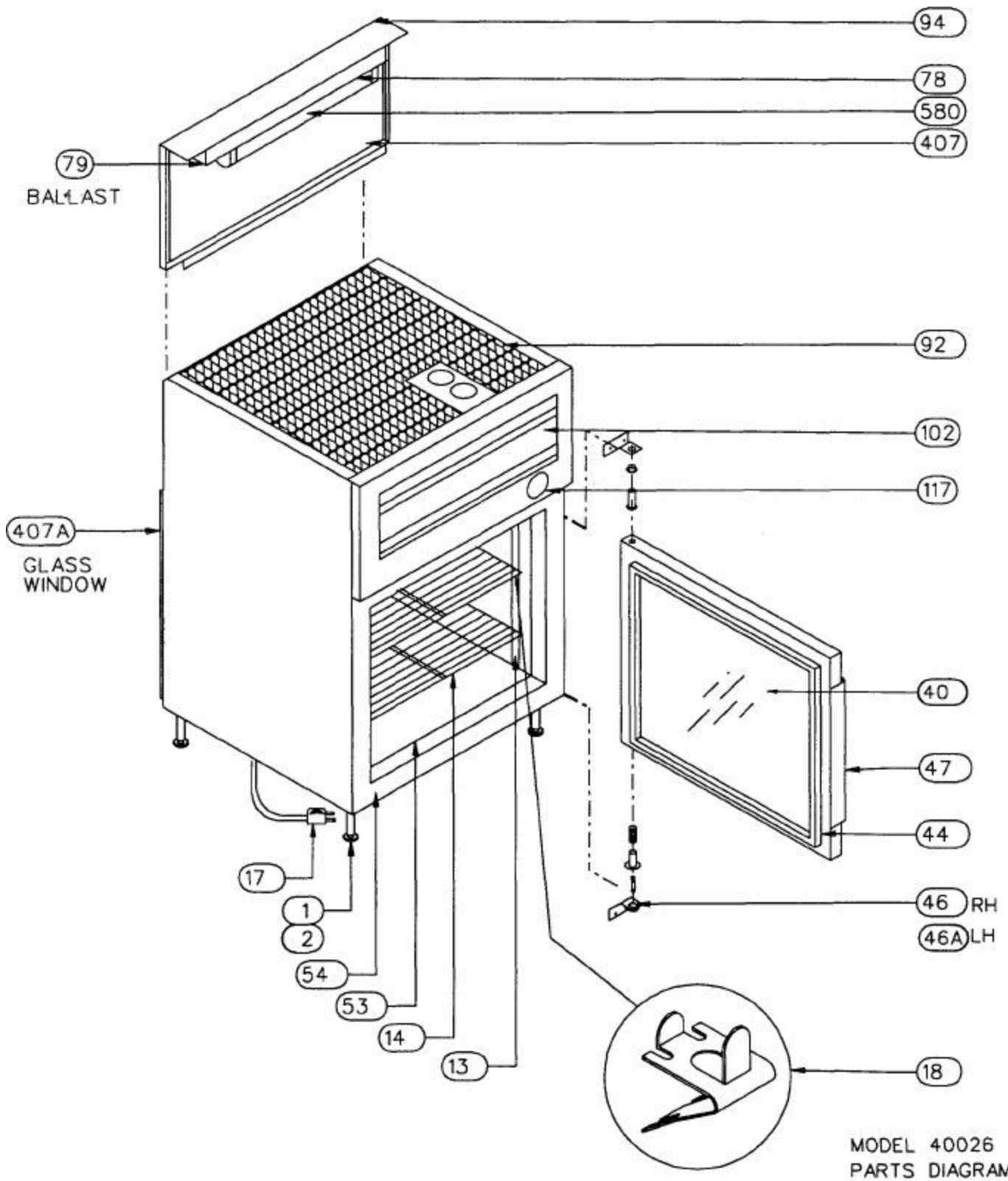

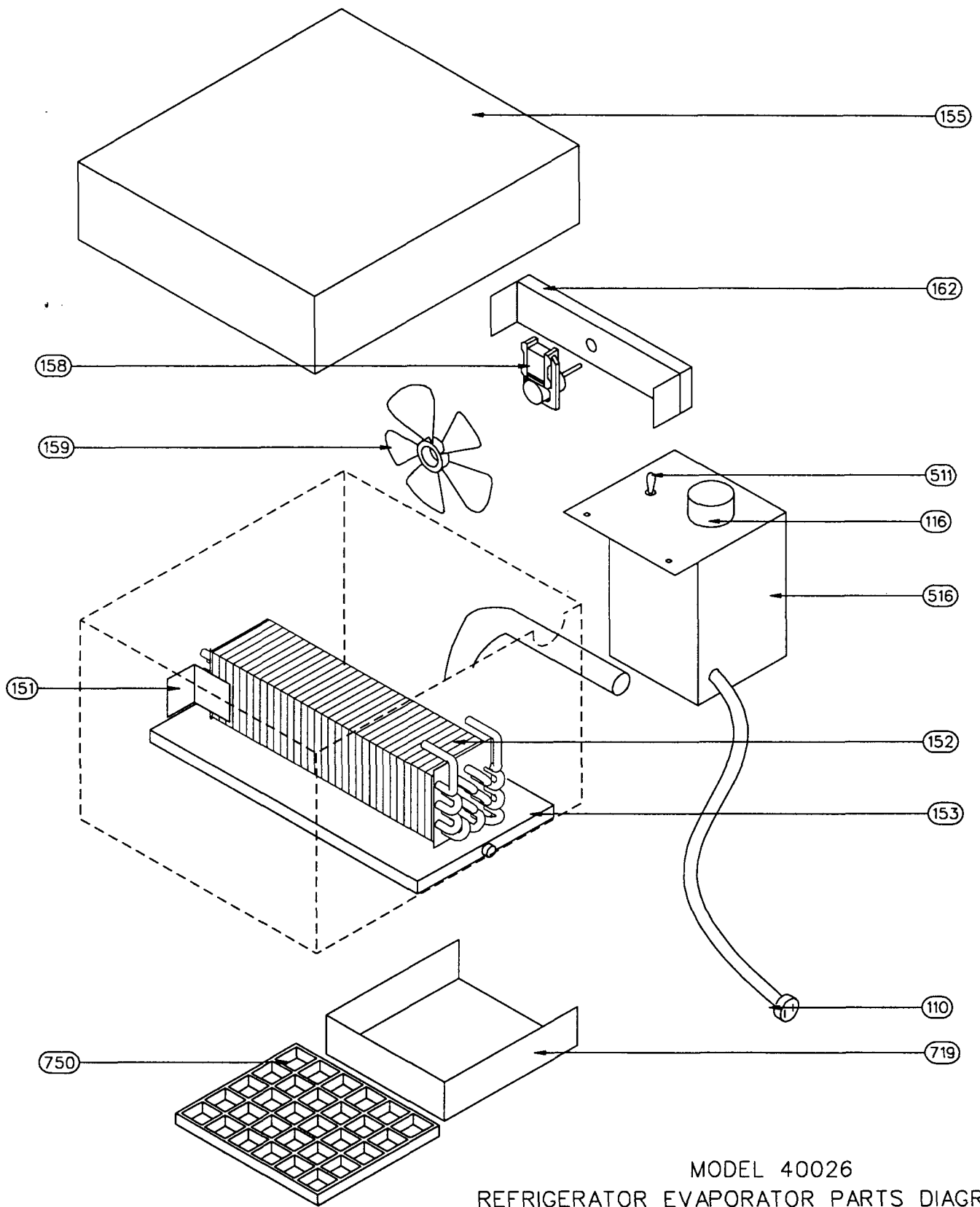

MODEL 40026
REFRIGERATOR EVAPORATOR PARTS DIAGRAM

(130) CONDENSING UNIT

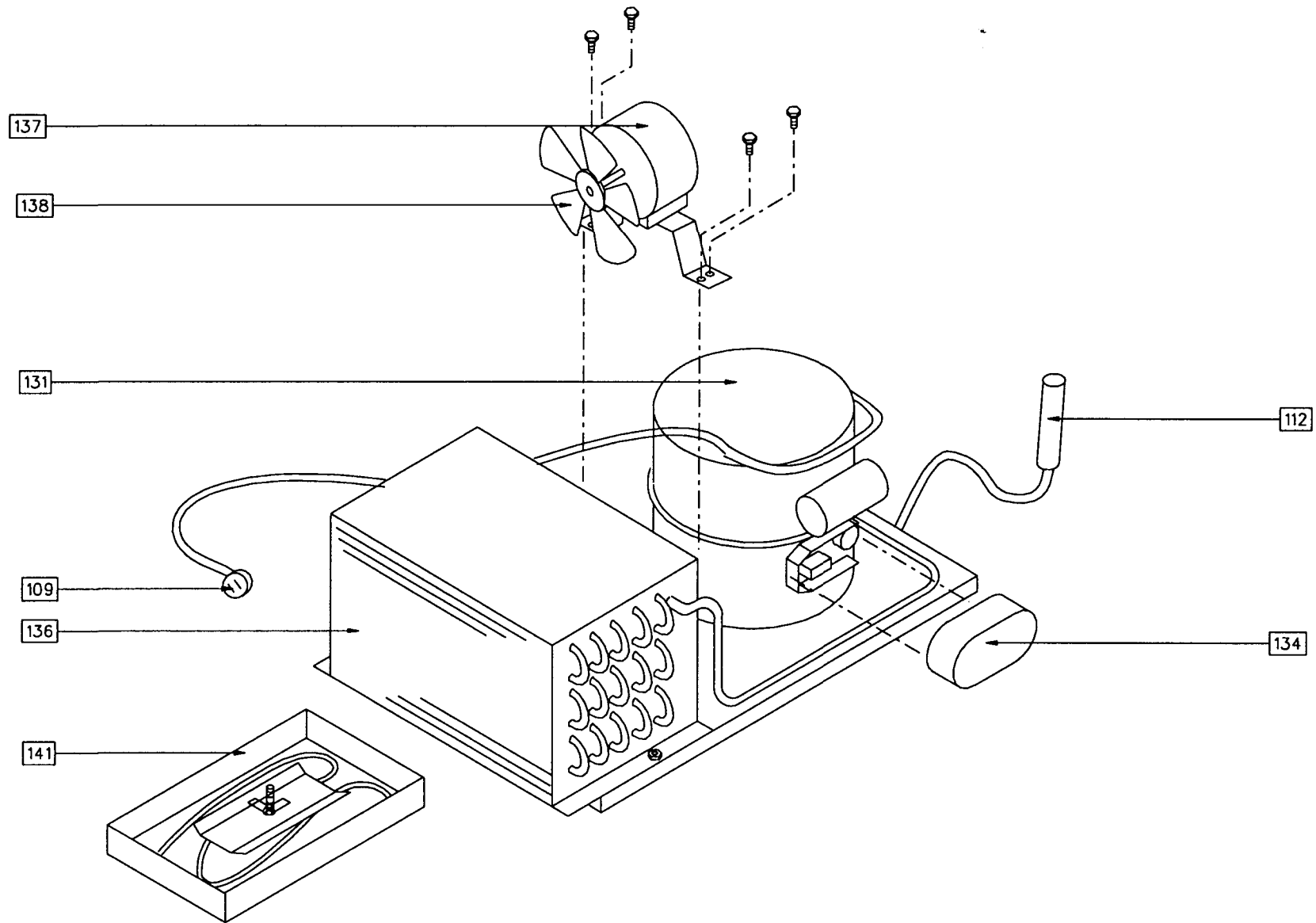

Randell Manufacturing., Inc.
Authorized Parts Distributors

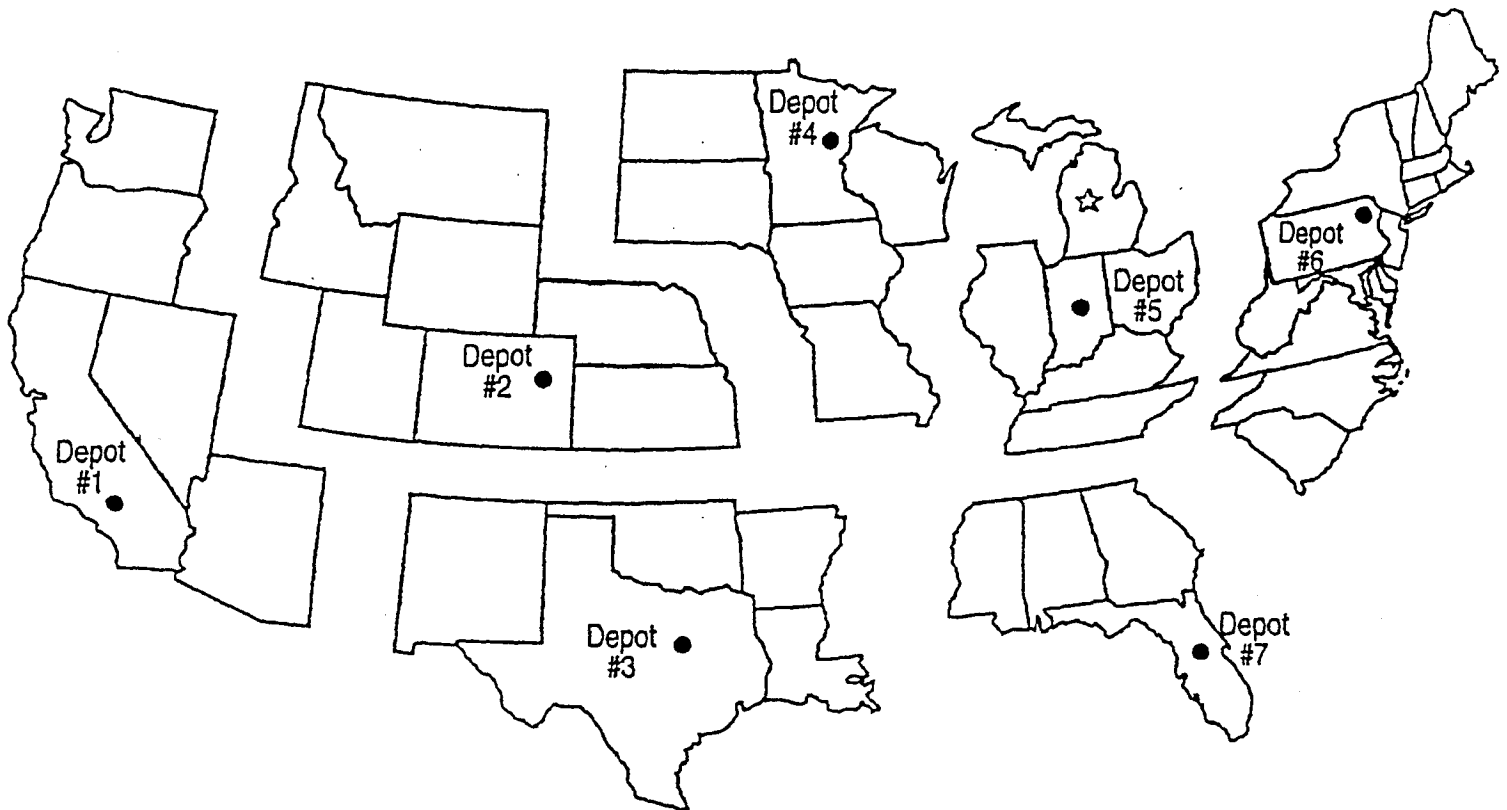

DEPOT #1
CASE PARTS CO.
877 Monterey Pass Road
Monterey Park, CA 91754 1-800-621-7884
(CA ONLY) 1-800-421-0271

DEPOT #2
REFRIGERATION HARDWARE SUPPLY
632 Foresight Circle
Grand Junction, CO 81505 1-800-423-2446
1-800-537-8300 (PAC. COAST)

DEPOT #3
STOVE PARTS SUPPLY
2120 Solona St.
Ft. Worth, TX 76117-0009
1-800-433-1804

DEPOT #4
GENERAL PARTS
11311 Hampshire Ave.
South Bloomington, MN 55438
1-800-279-9980

DEPOT #5
COMMERCIAL PARTS
5310 E. 25th Street P.O. Box 18688
Indianapolis, IN 46218-0688
1-800-727-8710

DEPOT #6
HARRISON SUPPLY
Ridley Creek Plaza 5153 West Chester Pike
P.O. Box 596
Edgemont, PA 19028
1-800-521-8444

DEPOT #7
WHITESIDE PARTS 722
Brookhaven Orlando.FL
32803 1-800-322-2678

☆
RANDELL MANUFACTURING., INC.
0520 S. Coldwater Road
Weidman, MI 48893
1-800-621-8560

