

OPERATOR MANUAL

IMPORTANT INFORMATION, KEEP FOR OPERATOR

This manual provides information on installation, operating, maintenance, trouble shooting & replacement parts for:

REFRIGERATORS:

51000 Series

53000 Series



THIS MANUAL MUST BE RETAINED FOR FUTURE REFERENCE. READ, UNDERSTAND AND FOLLOW THE INSTRUCTIONS AND WARNINGS CONTAINED IN THIS MANUAL.

WARNING / FOR YOUR SAFETY

Do not store or use gasoline or other flammable vapors and liquids in the vicinity of this or any other appliance.

WARNING

Improper installation, adjustment, alteration, service or maintenance can cause property damage, injury or death. Read the installation, operating and maintenance instructions thoroughly before installing or servicing this equipment.

NOTIFY CARRIER OF DAMAGE AT ONCE

It is the responsibility of the consignee to inspect the container upon receipt of same and to determine the possibility of any damage, including concealed damage. Randell suggests that if you are suspicious of damage to make a notation on the delivery receipt. It will be the responsibility of the consignee to file a claim with the carrier. We recommend that you do so at once.

Manufacture Service/Questions 888-994-7636.

Information contained in this document is known to be current and accurate at the time of printing/creation. Randell recommends referencing our product line websites, unifiedbrands.net, for the most updated product information and specifications.

PART NUMBER PP MNL1602, REV C (08/23)



888-994-7636, fax 888-864-7636
unifiedbrands.net

Part of  Electrolux
Professional
Group

IMPORTANT - READ FIRST - IMPORTANT

Congratulations on your recent purchase of Randell food service equipment, and welcome to the growing family of satisfied Randell customers.

Our reputation for superior products is the result of consistent quality craftsmanship. From the earliest stages of product design to successive steps in fabrication and assembly, rigid standards of excellence are maintained by our staff of designers, engineers, and skilled employees.

Only the finest heavy-duty materials and parts are used in the production of Randell brand equipment. This means that each unit, given proper maintenance will provide years of trouble free service to its owner.

In addition, all Randell food service equipment is backed by some of the best warranties in the food service industry and by our professional staff of service technicians.

Retain this manual for future reference.

NOTICE: DUE TO A CONTINUOUS PROGRAM OF PRODUCT IMPROVEMENT, RANDELL RESERVES THE RIGHT TO MAKE CHANGES IN DESIGN AND SPECIFICATIONS WITHOUT PRIOR NOTICE.

NOTICE: PLEASE READ THE ENTIRE MANUAL CAREFULLY BEFORE INSTALLATION. IF CERTAIN RECOMMENDED PROCEDURES ARE NOT FOLLOWED, WARRANTY CLAIMS WILL BE DENIED.

MODEL NUMBER _____

SERIAL NUMBER _____

INSTALLATION DATE _____

THE SERIAL NUMBER IS LOCATED IN THE CABINET LEFT SIDE UNDER THE DRAWER TRACK. AN EXAMPLE IS SHOWN BELOW.

Equipment Description



51362 shown with optional finished end

MODEL	LENGTH	DEPTH	WORK HEIGHT	REFRIGERATION	DOORS ²	H.P.	VOLT	AMPS	NEMA	SHIP WT (LBS)
SELF CONTAINED										
51347	47"	33"	36"	134A	(1)27" ¹	1/5	115	4.5	5-15P	410
51362	62"	33"	36"	134A	(2)24"	1/5	115	4.5	5-15P	480
51368	68"	33"	36"	134A	(2)27"	1/5	115	4.5	5-15P	510
51386	86"	33"	36"	134A	(3)24"	1/4	115	6.6	5-15P	600
51395	95"	33"	36"	134A	(3)27"	1/4	115	6.6	5-15P	660
51347PT-35	47"	35"	36"	134A	(2)27"	1/4	115	6.6	5-15P	268
51347PT-52	47"	52"	36"	134A	(2)27"	1/4	115	6.6	5-15P	336
51368PT-35	68"	35"	36"	134A	(4)27"	1/4	115	6.6	5-15P	344
51368PT-52	68"	52"	36"	134A	(4)27"	1/4	115	6.6	5-15P	439

¹ 6" coil housing is included.

² Drawers are available as an option.

MODEL	LENGTH	DEPTH	WORK HEIGHT	BTU	DOORS ^{2,3}	VOLT	AMPS	NEMA	SHIP WT (LBS)
REMOTE									
53330	30"	33"	36"	486	(1)24"	115	5.0	N/A	305
53333	33"	33"	36"	523	(1)21" ¹	115	5.0	N/A	320
53336	36"	33"	36"	561	(1)24" ¹	115	5.0	N/A	335
53339	39"	33"	36"	598	(1)27" ¹	115	5.0	N/A	350
53348	48"	33"	36"	895	(2)21"	115	5.0	N/A	380
53351	51"	33"	36"	933	(1)21" (1)24"	115	5.0	N/A	395
53354	54"	33"	36"	970	(2)24"	115	5.0	N/A	410
53357	57"	33"	36"	1008	(1)24" (1)27"	115	5.0	N/A	435
53360	60"	33"	36"	1045	(2)27"	115	5.0	N/A	450
53369	69"	33"	36"	1342	(3)21"	115	5.0	N/A	495
53372	72"	33"	36"	1380	(2)21" (1)24"	115	5.0	N/A	510
53375	75"	33"	36"	1417	(1)21" (2)24"	115	5.0	N/A	535
53378	78"	33"	36"	1455	(3)24"	115	5.0	N/A	550
53381	81"	33"	36"	1492	(2)24" (1)27"	115	5.0	N/A	565
53387	87"	33"	36"	1567	(3)27"	115	5.0	N/A	595
533102	102"	33"	36"	1939	(4)24"	115	5.0	N/A	655
533114	114"	33"	36"	2090	(4)27"	115	5.0	N/A	700

¹ 6" coil housing is included.

² Drawers are available as an option.

³ 6" mechanical housing is included.

Installation

**FAILURE TO FOLLOW INSTALLATION
GUIDELINES AND RECOMMENDATIONS MAY
VOID THE WARRANTY ON YOUR UNIT.**

SELECTING A LOCATION FOR YOUR NEW UNIT

The following conditions should be considered when selecting a location for your unit:

1. **Floor and Countertop Load:** The area on which the unit will rest must be level, free of vibration, and suitably strong enough to support the combined weights of the unit plus the maximum product load weight.
2. **Clearance:** Clearance must be a combined total of at least 3" on all sides and back of unit. Do not place any object that can block the ventilation exhaust from the machine compartment register.
3. **Ventilation:** The air cooled self-contained unit requires a sufficient amount of cool clean air. Avoid surrounding your equipment stand around other heat generating equipment and out of direct sunlight. Also, avoid locating in an unheated room or where the room temperature may drop below 55°F or above 86°F.

INSTALLATION CHECKLIST

After the final location has been determined, refer to the following checklist prior to start-up:

1. Check all exposed refrigeration lines to ensure that they are not kinked, dented, or rubbing together.
2. Check that the condenser and evaporator fans rotate freely without striking any stationary members.
3. Unit must be properly leveled; check all legs or casters to ensure they all are in contact with the floor while maintaining a level work surface. Adjusting bullet feet heights or shimming casters may be necessary if the floor is not level. **NOTE:** Damage to equipment may result if not followed. Randell is not responsible for damage to equipment if improperly installed.
4. Plug in unit and turn on main on/off power switch. The main power switch is located in the compressor mechanical housing.
5. Allow unit time to cool down to temperature. If temperature adjustments are required, the temperature control is located on the evaporator coil within the refrigerated base (refer to page 10). Confirm that the unit is holding the desired temperature.
6. Refer to the front of this manual for serial number location. Please record this information in your manual on page 2 now. It will be necessary when ordering replacement parts or requesting warranty service.
7. Before putting in food, allow your unit to operate for approximately two (2) hours so that interior of the unit is cooled down to storage temperature.
8. Check doors to ensure there is proper sealing and alignment.
9. For units with self-closing doors: Check doors to ensure they open and shut freely.
Note: All motors are oiled and sealed
Note: All self-contained models are shipped from the factory with the service valves open and ready for operation.

Installation

IT IS IMPORTANT THAT A VOLTAGE READING BE MADE AT THE COMPRESSOR MOTOR ELECTRICAL CONNECTIONS, WHILE THE UNIT IS IN OPERATION TO VERIFY THE CORRECT VOLTAGE REQUIRED BY THE COMPRESSOR IS BEING SUPPLIED. LOW OR HIGH VOLTAGE CAN DETRIMENTALLY AFFECT OPERATION AND THEREBY VOID ITS WARRANTY.

IT IS IMPORTANT THAT YOUR UNIT HAS ITS OWN DEDICATED LINE. CONDENSING UNITS ARE DESIGNED TO OPERATE WITH A VOLTAGE FLUCTUATION OF PLUS OR MINUS 10% OF THE VOLTAGE INDICATED ON THE UNIT DATA TAG. BURN OUT OF A CONDENSING UNIT DUE TO EXCEEDING VOLTAGE LIMITS WILL VOID THE WARRANTY.

ELECTRICAL SUPPLY

Any wiring should be done by a qualified electrician in accordance with local electrical codes. A properly wired and grounded outlet will assure proper operation. Please consult the data tag attached to the compressor to ascertain the correct electrical requirements. Supply voltage and amperage requirements are located on the serial number tag located inside the mechanical housing.

BULLET-FEET ADJUSTMENT

The legs are equipped with bullet-type leveling bolts. Turn bolts clockwise or counterclockwise until the unit is level (both right to left and front to back). This can be done by hand or with an open end wrench.

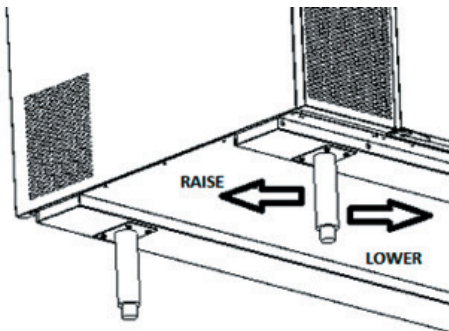

Operation



Allow unit to operate for approximately two (2) hours before placing in food.

AMBIENT CONDITIONS

This unit is designed for indoor operation in a room with maximum ambient 86°F and 55% relative humidity or less. It should never be used outside or located in direct sunlight.

Randell has attempted to preset the temperature control to ensure that your unit runs at an optimum temperature, but due to varying ambient conditions, including elevation, food type and your type of operation, you may need to alter this temperature using control adjustment until desired temperature is reached.

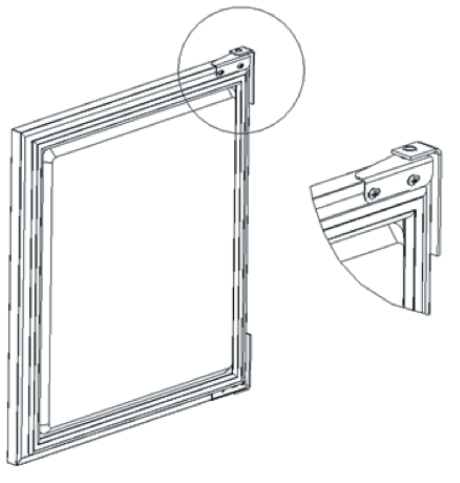

BEFORE MAKING TEMPERATURE ADJUSTMENTS

1. Make sure that you are allowing adequate time for the cabinet temperature to equalize. When initially started or when first loaded, it can take a long time for temperatures in the display area to stabilize.
2. Make sure that unit operation is not being effected by room ambient conditions. (See Ambient Conditions section above). If there are any significant ambient issues, adjusting the temperature setting may not help.

TO RAISE TEMPERATURE

1. Turn knob counterclockwise, keeping the arrow on the knob pointed within the arc.
2. Turning counterclockwise beyond the arc can result in shutting off of the compressor.

TO LOWER TEMPERATURE

1. Turn knob clockwise, keeping the arrow on the knob pointed within the arc.
2. Turning clockwise beyond the arc can result in freeze-up.

DOOR ADJUSTMENT

The doors are mounted to the cabinet with two screws on the upper hinge, and a hinge pin on the bottom. To adjust the door, first open it to 90° and loosen the two screws enough to reposition the door. Once repositioned, retighten all screws.

Maintenance

DO NOT USE SHARP UTENSILS AND/OR OBJECTS.

BRUSH COIL IN DIRECTION OF FINS, NORMALLY VERTICALLY AS TO NOT DAMAGE OR RESTRICT AIR FROM PASSING THROUGH CONDENSER.

DO NOT USE STEEL PADS, WIRE BRUSHES, SCRAPERS, OR CHLORIDE CLEANERS TO CLEAN YOUR STAINLESS STEEL.

**CAUTION
DO NOT USE ABRASIVE CLEANING SOLVENTS, AND NEVER USE HYDROCHLORIC ACID (MURIATIC ACID) ON STAINLESS STEEL.**

DO NOT PRESSURE WASH EQUIPMENT AS DAMAGE TO ELECTRICAL COMPONENTS MAY RESULT.

Randell strongly suggests a preventive maintenance program which would include the following **Monthly** procedures:

1. Cleaning of all condenser coils. Condenser coils are a critical component in the life of the compressor and must remain clean to assure proper air flow and heat transfer. Failure to maintain this heat transfer will affect unit performance and eventually destroy the compressor. Clean the condenser coils with coil cleaner and/or a vacuum, cleaner and brush. Use of any filter over the condenser coil may result in poor performance of the equipment. The factory does not recommend any auxiliary filter be used on the condenser coil. Any failures of the unit as a result of an auxiliary filter will not be covered under warranty.
2. Clean fan blade on the condensing unit and evaporator assembly.
3. Clean and disinfect drain, drain lines and evaporator pan with a solution of warm water and mild detergent.
4. Clean all gaskets on a weekly if not daily basis with a solution of warm water and a mild detergent to extend gasket life.
5. Lubricate door hinges with lithium grease.
6. Clean drawer tracks of any debris.
7. The drawer module may be removed from the cabinet for cleaning by loosening the two $\frac{3}{4}$ " round screws on rear anchor bracket. Once loosened the drawer cartridge may be removed from the cabinet to clean the interior of the cabinet. Clean with mild soap and warm water mixture. Re-install the drawer cartridge by properly aligning the cartridge to the bracket and tightening the $\frac{3}{4}$ " round screws.
8. Inspect all silicone seams at interior of the base cabinet on a monthly basis. Re-apply food grade silicone sealant as needed to any seams where silicone has peeled away or cracked. Apply silicone to a clean dry surface. Allow sufficient drying time to assure best adhesion of sealant.

RECOMMENDED CLEANERS FOR YOUR STAINLESS STEEL INCLUDE THE FOLLOWING:

JOB	CLEANING AGENT	COMMENTS
Routine cleaning	Soap, ammonia, detergent Medallion	Apply with a sponge or cloth
Fingerprints and smears	Arcal 20, Lac-O-Nu, Ecoshine	Provides a barrier film
Stubborn stains and discoloration	Cameo, Talc, Zud, First Impression	Rub in the direction of the polish lines
Greasy and fatty acids, blood, burnt-on foods	Easy-Off, Degrease It, Oven Aid	Excellent removal on all finishes
Grease and Oil	Any good commercial detergent	Apply with a sponge or cloth
Restoration/Preservation	Benefit, Super Sheen	Good idea monthly

Reference: Nickel Development Institute, Diversey Lever, Savin, Ecolab, NAFEM

Maintenance

To remove and re-install drawer tracks, please refer to figure below for instructions.

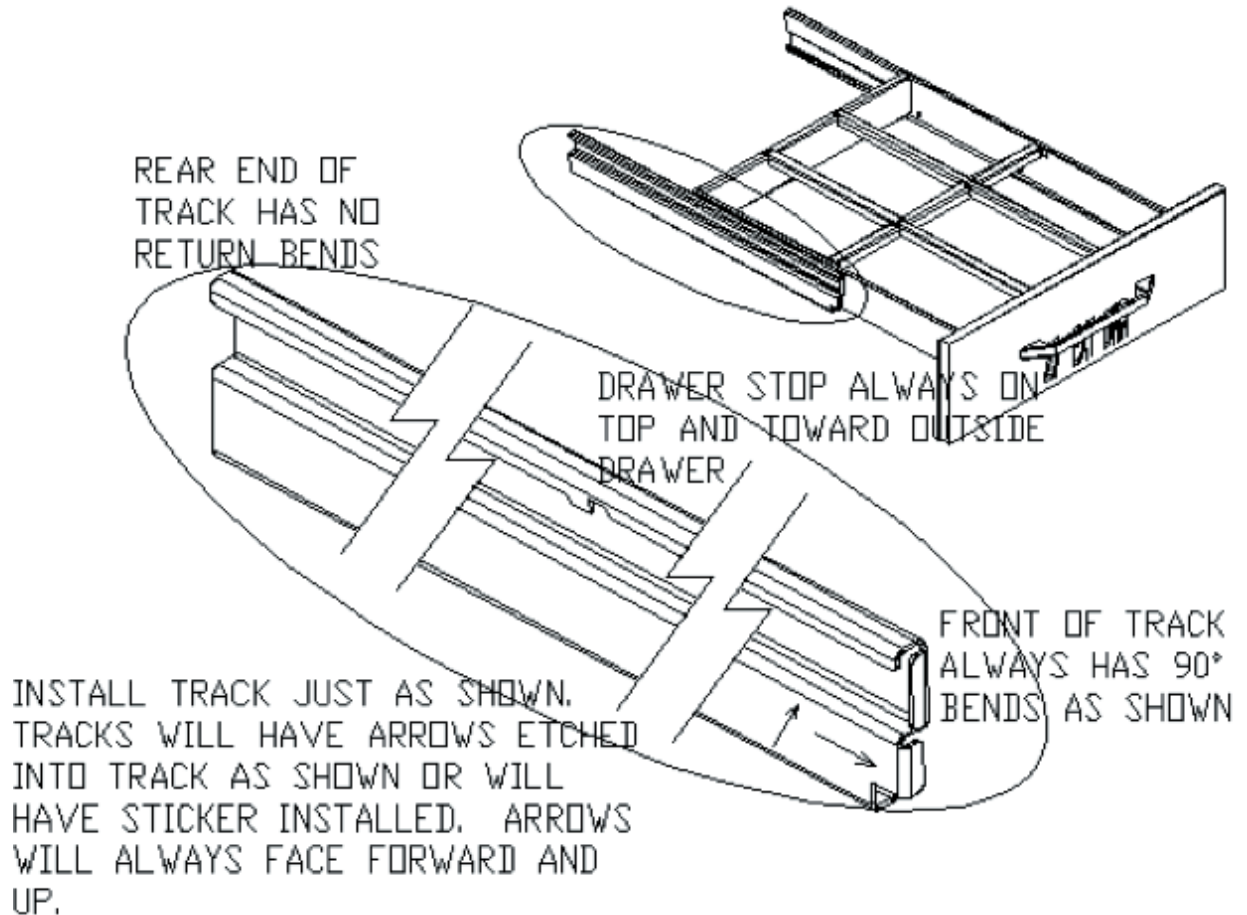

Proper maintenance of equipment is the ultimate necessity in preventing costly repairs. By evaluating each unit on a regular schedule, you can often catch and repair minor problems before they completely disable the unit and become burdensome on your entire operation.

For more information on preventive maintenance, consult your local service company or CFESA member. Most repair companies offer this service at very reasonable rates to allow you the time you need to run your business along with the peace of mind that all your equipment will last throughout its expected life. These services often offer guarantees as well as the flexibility in scheduling or maintenance for your convenience.

For a complete listing of current Randell ASAs, please visit www.unifiedbrands.net.

Randell believes strongly in the products it manufactures and backs those products with one of the best warranties in the industry. We believe with the proper maintenance and use, you will realize a profitable return on your investment and years of satisfied service.

Troubleshooting

This unit is designed to operate smoothly and efficiently if properly maintained. However, the following is a list of checks to make in the event of a problem. Wiring diagrams are found at the end of this manual.

SYMPTOM	POSSIBLE CAUSE	PROCEDURE
Unit does not run	<ol style="list-style-type: none"> 1. No power to unit 2. Temperature control turned off 3. Temperature control faulty 4. Compressor overheated 5. Condenser fan faulty 6. Overload protector faulty 7. Compressor relay faulty 8. Compressor faulty 	<ol style="list-style-type: none"> 1. Plug in unit 2. Check temperature control 3. Test temperature control 4. Clean condenser coil 5. Service condenser fan 6. Test overload 7. Test relay 8. Call for service at 888-994-7636
Unit short cycles	<ol style="list-style-type: none"> 1. Condenser coil dirty 2. Condenser fan faulty 3. Compressor faulty 4. Overload repeatedly tripping 	<ol style="list-style-type: none"> 1. Clean coil 2. Service fan and motor. 3. Call for service at 888-994-7636 4. Check outlet voltage
Unit runs constantly	<ol style="list-style-type: none"> 1. Condenser coil dirty 2. Condenser fan faulty 	<ol style="list-style-type: none"> 1. Clean coil 2. Service condenser motor
Unit not cold enough	<ol style="list-style-type: none"> 1. Temperature control set too high 2. Temperature control faulty 3. Condenser coil dirty 4. Refrigerant leaking or contaminated 	<ol style="list-style-type: none"> 1. Adjust control to lower setting 2. Test control 3. Clean coil 4. Call for service at 888-994-7636
Unit too cold	<ol style="list-style-type: none"> 1. Temperature control set too low 2. Temperature control faulty 	<ol style="list-style-type: none"> 1. Adjust control to raise setting 2. Test control
Drawer Issues	<ol style="list-style-type: none"> 1. Drawer tracks backwards 2. Roller bearings loose 	<ol style="list-style-type: none"> 1. Check installation of drawer track – page 12 2. Tighten bearings
Unit noisy	<ol style="list-style-type: none"> 1. Compressor mountings loose or hardened 2. Condenser fan damaged or hitting fan shroud 	<ol style="list-style-type: none"> 1. Tighten or replace compressor mountings 2. Inspect condenser fan
Moisture around door or frame	<ol style="list-style-type: none"> 1. Breaker strip faulty 2. Frame heater faulty 3. Temperature control set too low 	<ol style="list-style-type: none"> 1. Inspect strips 2. Call for service at 888-994-7636 3. Adjust control to raise setting
Ice in drain pan or water in bottom of unit or floor	<ol style="list-style-type: none"> 1. Drain tube clogged 2. Unit not level 	<ol style="list-style-type: none"> 1. Clean drain 2. Adjust leveling feet

When in doubt, turn unit off and call for service and call for service at 888-994-7636.

Troubleshooting

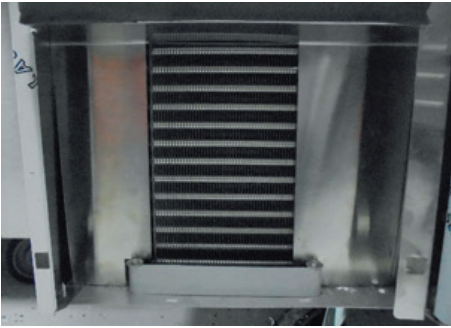

CLEANING CONDENSOR COIL

An accumulation of dirt and dust prevents the condenser coil from removing, making your unit cool poorly, run constantly, or even stop completely if the compressor overheats. Clean coil using a vacuum cleaner with wand attachment. If the coil is greasy, wash it with a solution of warm water the mild detergent using a bristle brush. Take care not to drip water onto other parts of the condensing unit.



CLEANING DRAIN AND DRAIN PAN

Clean the drain using an oven baster to force a solution of hot water and baking soda or bleach into the drain opening. To clear a stubborn clog, insert a length of 1/4" round plastic tubing into the drain and push it gently through to the drain pan; pull back out. Wash the drain pan regularly with a solution of warm water and baking soda.

CHECKING THE DOOR SEAL

Open the door and examine all four sides of the door gasket for any tears. Feel the gasket for brittleness and/or cracks. If the gasket shows damage, then it must be replaced. If no damage is observed, close the door and check the seal between the gasket and the cabinet for obvious gaps. Next open the door and close it on a dollar bill. Slowly pull the dollar bill out from the door. If the gasket seals properly, you will feel tension as it grips the bill. Repeat this test all around the door. If the gasket does not seal tightly, replace the gasket after first checking the door for any sagging or warping.



SERVICING THE CONDENSER FAN

Inspect the condenser fan motor by removing the mechanical housing cover to gain access. Unplug the unit. Clean the fan blade, and turn it to see if the blade rotates freely. If the motor binds, replace it. If any damage to the blade is observed, unscrew the retaining nut that holds the blade to the motor shaft and pull the blade off the shaft. Install a new fan blade, replacing any washers, and tighten the retaining nut. To test the condenser fan motor, disconnect the wires to the fan motor. Using a multimeter set at RX10, touch one probe to each terminal. The multimeter needle should show approximately 45 to 50 ohms resistance. A lower reading indicates the motor is faulty and needs to be replaced.



Next, set the multimeter at RX1000 and touch one probe to the motor terminals and the other probe to any unpainted metal part of the unit. If the multimeter needle moves, the motor is grounded and needs to be replaced. To remove the motor, unscrew the bracket that holds the fan motor to its housing. Slide the motor out of the housing. Remove the fan blade from the old motor and attach to the new motor, replacing any washers. Install the new motor in its housing by screwing the bracket into place. Reattach the wires to the motor terminals and reconnect the ground wire.

Troubleshooting



SERVICING THE COMPRESSOR

The compressor is part of the sealed refrigeration system and should be replaced by a professional service technician. You can, however, test the compressor and certain components. Prior to testing, unplug the unit and remove the access cover to the mechanical housing. A small box mounted on the side of the compressor protects the relay, overload protector, and capacitor. Release the wire retaining clip that holds the cover in place and slip off the cover and the clip.

To test the compressor relay, pull the relay straight off the compressor without twisting or damaging it. If the relay has an external wire coil, hold the relay so that the word TOP is up. Using a multimeter set at RX1, place the probes on terminals S and M. The multimeter needle should not move. Remove the probe from terminal M and place it on the side terminal marked L. The multimeter needle should not move. Remove the probe from terminal S and place it on terminal M. The multimeter needle should sweep across the scale, indicating full continuity.

Turn the relay upside down. Using a multimeter set at RX1, place the probes on terminals S and M. The multimeter needle should sweep across the scale, indicating full continuity. Remove the probe from terminal M and place it on the side terminal marked L. The multimeter needle should sweep across the scale, indicating fully continuity. Remove the probe from terminal S and place it on terminal M. The multimeter needle should not move. If the relay fails any of the tests listed above, the relay is faulty and needs to be replaced. Push a new relay onto the compressor terminals and replace the terminal cover. If the relay passes all the tests listed above, proceed to testing of the overload protector.

To remove the overload protector, use a screwdriver to gently pry open the circular spring clip that secures the overload protector to the compressor and snap out the overload protector. Pull the two wire connectors off the terminals. Using a multimeter set at RX1, touch a probe to each overload protector terminal. The multimeter needle should sweep across the scale, indicating full continuity. If the overload protector passes this test, proceed to testing of the compressor. If the overload protector fails this test, the overload protector is faulty and needs to be replaced. Reattach the push-on connectors to the new overload protector, clip it in place on the compressor, and replace the terminal cover.

For testing the compressor, use a multimeter set at RX1 to test each of the three terminal pins against each of the other two terminal pins. Each pair should show continuity. Then, with the multimeter set at RX1000, place one probe against the metal housing of the compressor (if necessary, scrape off a small amount of paint to ensure contact with bare metal). Place the other probe on each of the three terminals in turn. If any of the three terminals shows continuity with the housing, the compressor is grounded. If the compressor fails either test, call for service at 888-994-7636. If the compressor passes the tests, reinstall the overload protector, relay, terminal cover, and mechanical housing cover.

Parts List

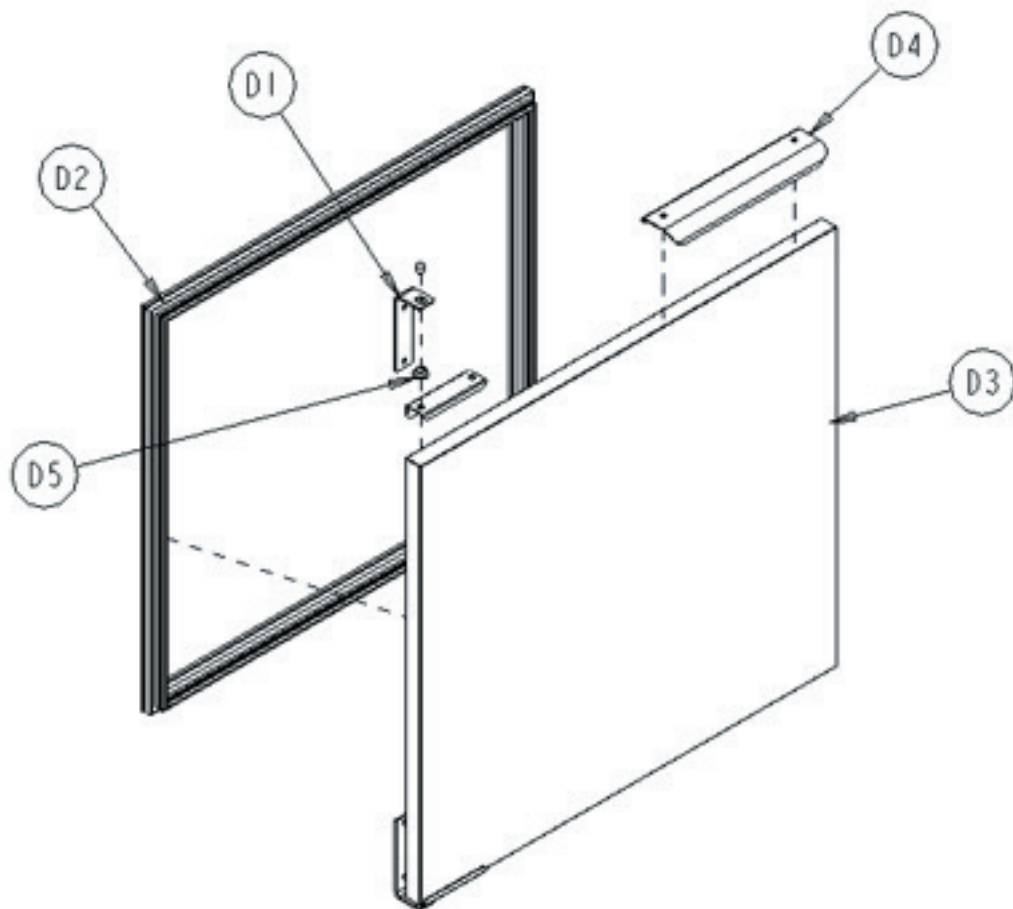

ITEM	DESCRIPTION	PART NUMBER	51347	51347PT	51362	51368	51368PT	51386	51395
D1	DOOR HINGE – NON-SELF CLOSING	RP HNG9900	X	X	X	X	X	X	X
D2	DOOR GASKET – 18.5 X 22.5	IN GSK1006							
D2	DOOR GASKET – 21.75 X 22.5	IN GSK1010			X			X	
D2	DOOR GASKET – 24.5 X 22.5	IN GSK1015	X	X		X	X		X
D3	DOOR LEFT HAND – 21 X 24.5	RP DOR0012							
D3	DOOR LEFT HAND – 24 X 24.5	RP DOR0015			X			X	
D3	DOOR LEFT HAND – 27 X 24.5	RP DOR0016	X	X		X	X		X
D3	DOOR RIGHT HAND – 21 X 24.5	RP DOR0013							
D3	DOOR RIGHT HAND – 24 X 24.5	RP DOR0017			X			X	X
D3	DOOR RIGHT HAND – 27 X 24.5	RP DOR0018	X	X		X	X		X
D4	DOOR HANDLE	RP HDL037	X	X	X	X	X	X	X
D5	DOOR HINGE BUSHING	HD BSH050	X	X	X	X	X	X	X

Parts List

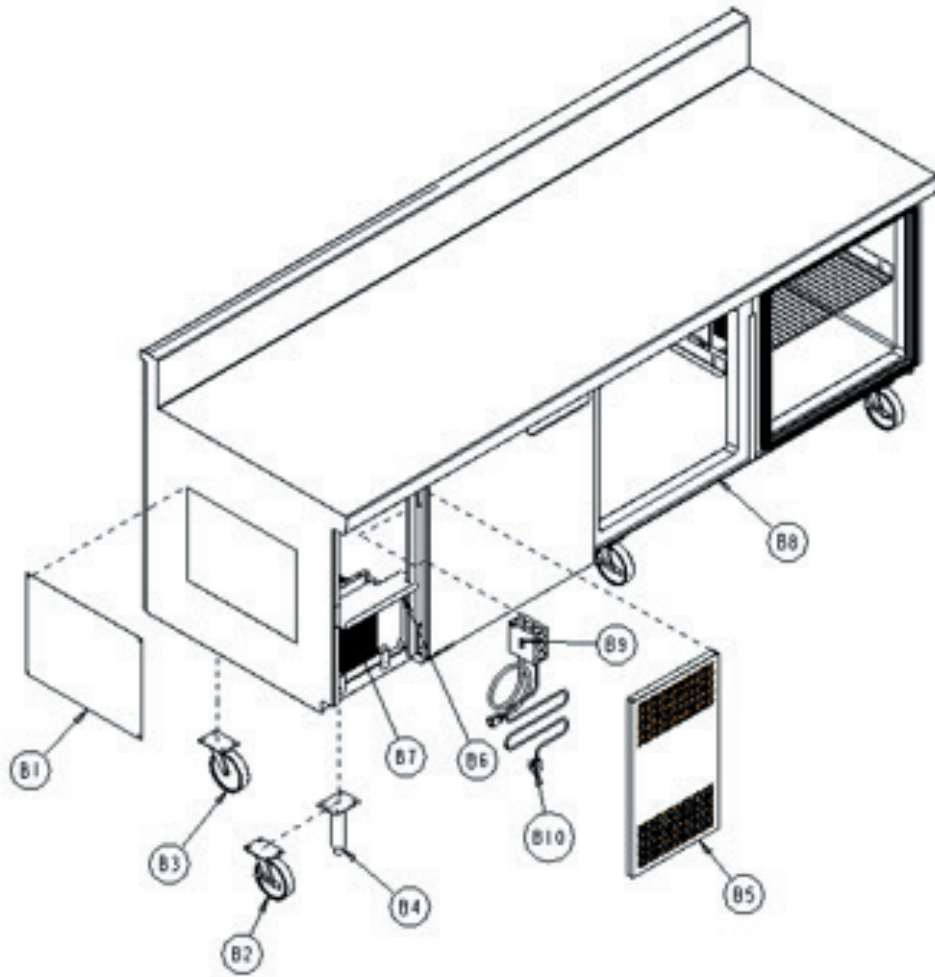

Parts List

ITEM	DESCRIPTION	PART NUMBER	51347	51347PT	51362	51368	51368PT	51386	51395
B2	CASTER W/BREAK – 4" (OPTION)	HD CST040HD	X	X	X	X	X	X	X
B2	CASTER W/BREAK – 6" (OPTION)	HD CST060	X	X	X	X	X	X	X
B3	CASTER W/O BREAK – 4" (OPTION)	HD CST041HD	X	X	X	X	X	X	X
B3	CASTER W/O BREAK – 6" (OPTION)	HD CST061	X	X	X	X	X	X	X
B4	LEG W/BULLET FOOT – 6"	HD LEG9902	X	X	X	X	X	X	X
B5	LOUVER	CALL FACTORY	X	X	X	X	X	X	X
B5*	LOUVER MAGNET	HD CTH9901	X	X	X	X	X	X	X
B5*	LOUVER MAGNET STRIKE	HD STR9901	X	X	X	X	X	X	X
B5*	LOUVER MOUNT HINGE BRACKET	RP BRK0109	X	X	X	X	X	X	X
B7	COMPRESSOR (AE4425Y AFTER AUG 2016)	RF CMP1608	X		X	X			
B7	COMPRESSOR (AE4430Y AFTER AUG 2016)	RF CMP1406						X	X
B7	COMPRESSOR (AE4430Y BEFORE AUG 2016)	RF CMP1406	X		X	X			
B7	COMPRESSOR (AE4440Y BEFORE AUG 2016)	RF CMP1402						X	
B7	COMPRESSOR (AE4450Y BEFORE AUG 2016)	RF CMP1403							X
B7	CONDENSING UNIT (AE4425Y AFTER AUG 2016)	RF CON1504	X		X	X			
B7	CONDENSING UNIT (AE4430Y BEFORE AUG 2016)	RF CON1404	X	X	X	X	X		
B7	CONDENSING UNIT (AE4430Y AFTER AUG 2016)	RF CON1404-HLS						X	X
B7	CONDENSING UNIT (AE4440Y BEFORE AUG 2016)	RF CON1414						X	
B7	CONDENSING UNIT (AE4450Y BEFORE AUG 2016)	RF CON1412							X
B7	CONDENSER FAN MOTOR W/BLADE	RF ASY1200P	X	X	X	X	X	X	
B7	CONDENSER FAN BLADE	RF BLD0101	X	X	X	X	X	X	X
B7	CONDENSER FAN MOTOR	RF MTR0104	X	X	X	X	X	X	X
B7	FILTER DRIER	RF FLT251	X	X	X	X	X	X	X
B7*	POWER CORD (CONDENSING UNIT)	EL WIR470	X	X	X	X	X	X	X
B7*	TXV (BASE)	RF VLV200	X	X	X	X	X	X	X
B9	SWITCH, ROCKER ON/OFF	EL SWT0502	X	X	X	X	X	X	X
B10	POWER CORD 16/3 – 9'	EL WIR461-90	X	X	X	X	X	X	X
*	TRAY RACK	1120	X		X	X		X	X

Parts List

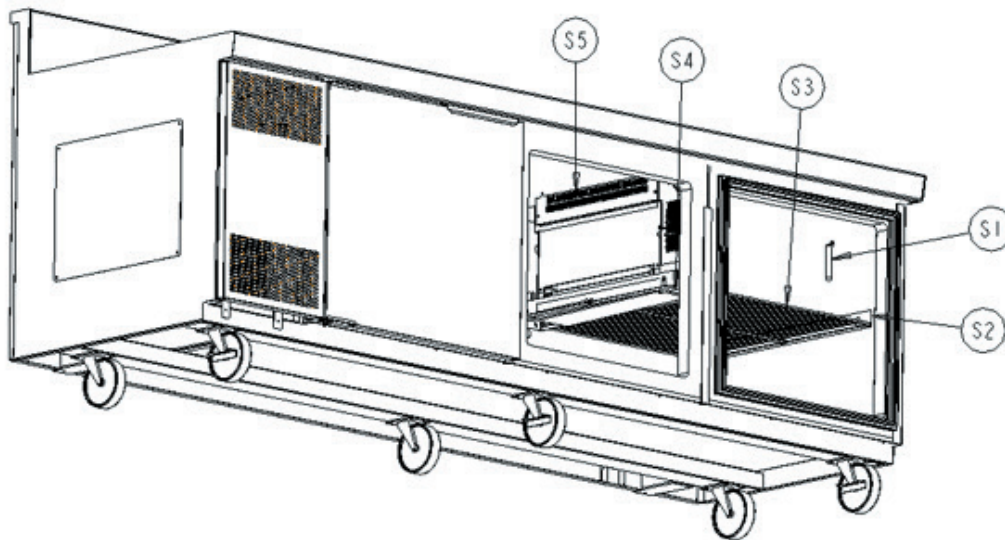

ITEM	DESCRIPTION	PART NUMBER	51347	51347PT	51362	51368	51368PT	51386	51395
S1	HANGING THERMOMETER – 4”	HD THR100	X	X	X	X	X	X	X
S2	SHELF SUPPORT – BETWEEN DOORS	RP BRK0108	X		X	X		X	X
S2	SHELF SUPPORT – FRONT & BACK	RP BRK0107		X			X	X	X
S2	SHELF SUPPORT – PASS THRU 52”	CALL FACTORY		X			X		
S2*	SHELF SUPPORT PIN	HD PIN0102	X		X	X		X	X
S3	SHELF – 16.15 X 25	HD SHL9912							
S3	SHELF – 19 X 25	HD SHL160							
S3	SHELF – 22 X 25	HD SHL180		X (35 DEPTH)			X (35 DEPTH)		
S3	SHELF – 22-1/8 X 21-1/4	HD SHL184		X (52 DEPTH)			X (52 DEPTH)		
S4	BULB, LED, EDISON BASE, 3 WATTS	EL LGT1411	X	X	X	X	X	X	X
S5	EVAPORATOR COIL ASSEMBLY	RF CSY0106LR-D14			X	X			
S5	EVAPORATOR COIL ASSEMBLY (AFTER AUGUST 2016)	RF CSY0106LR-D17	X						
S5	EVAPORATOR COIL ASSEMBLY (BEFORE AUGUST 2016)	RF CSY0106LR-D14	X						
S5	EVAPORATOR COIL ASSEMBLY, W/CONTROL (AFTER AUGUST 2016)	RF CSY0106-D17						X	X
S5	EVAPORATOR COIL ASSEMBLY, W/CONTROL (BEFORE AUGUST 2016)	RF CSY0106-D14						X	X
S5	EVAPORATOR COIL ASSEMBLY, W/O CONTROL (AFTER AUGUST 2016)	RF CSY0702-D17						X	X
S5	EVAPORATOR COIL ASSEMBLY, W/O CONTROL (BEFORE AUGUST 2016)	RF CSY0702-D14						X	X
S5	EVAPORATOR COIL ASSEMBLY (AFTER DECEMBER 2016)	RF CSY5147PT-52-D17		X					
S5	EVAPORATOR COIL ASSEMBLY (AFTER DECEMBER 2016)	RF CSY5168PT-52-D17					X (52 DEPTH)		
S5	EVAPORATOR COIL ASSEMBLY (AFTER MARCH 2017)	RF CST5168PT-35-D17					X (35 DEPTH)		

Parts List

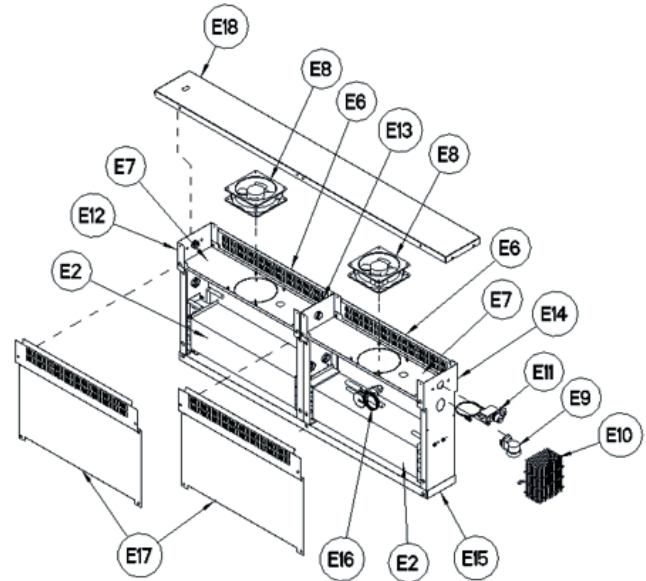
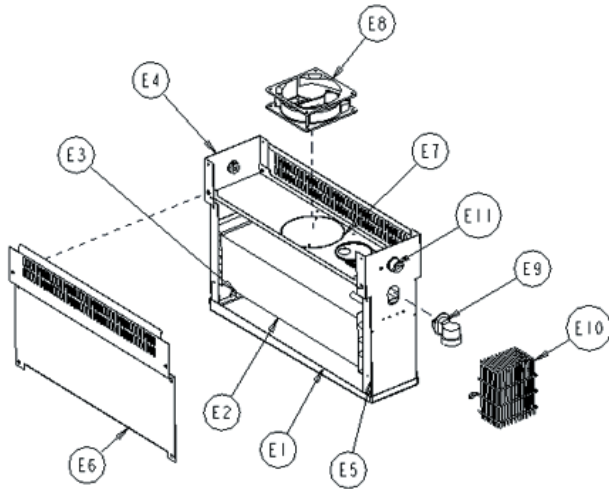

ITEM	DESCRIPTION	PART NUMBER	51347	51347PT	51362	51368	51368PT	51386	51395
E1	EVAPORATOR DRIP PAN – PLASTIC	RD DRP107	X	X	X	X		X	X
E2	EVAPORATOR COIL	RF COI107	X	X	X	X	X	X	X
E3	EVAPORATOR COIL DRAIN TUBE	PL TBG075	X	X	X	X	X	X	X
E4	EVAPORATOR COIL HOUSING – REAR PANEL	RP PNL108	X		X	X		X	X
E5	EVAPORATOR COIL HOUSING – FRONT PANEL	RP PNL109	X		X	X		X	X
E6	EVAPORATOR COIL HOUSING – SIDE	RP PNL107	X	X	X	X		X	X
E6	EVAPORATOR COIL HOUSING – SIDE (W/O PERFS, 13” – NOT SHOWN)	RP PNL1617		X					
E7	EVAPORATOR FAN MOUNTING SHROUD (SINGLE FAN)	RP SHD1602	X	X	X	X	X	X	X
E8	EVAPORATOR FAN MOTOR – AXIAL 119MM X 38MM, 115V	RF FAN1401	X		X	X			
E9	EVAPORATOR FAN MOTOR – AXIAL 119MM X 38MM, 12VDC (AFTER AUGUST 2016)	RF FAN1402		X			X	X	X
E9	SOCKET, LIGHT	EL LGT360	X	X	X	X	X	X	X
E10	GUARD, WIRE - LIGHT	HD GRD1159	X	X	X	X	X	X	X
E11	THERMOSTAT/CONTROL	HD CNT1401	X	X	X	X	X	X	X
E12	EVAPORATOR COIL HOUSING – END PLATE W/LIGHT CUTOUT	RP PNL1616		X			X		
E13	EVAPORATOR COIL HOUSING – CENTER PLATE	CALL FACTORY					X		
E14	EVAPORATOR COIL HOUSING – END PLATE W/O LIGHT CUTOUT	RP PNL1615		X			X		
E15	EVAPORATOR COIL HOUSING – DRAIN PAN	RP PNL1601					X		
E16	TXV VALVE	RF VLV200		X			X		
E17	EVAPORATOR COIL HOUSING – SIDE (W/ PERFS, 13”)	RP PNL1614		X			X		
*	EVAPORATOR COIL MOUNTING BRACKET	RP BRK007	X		X	X		X	X
*	EVAPORATOR COIL MOUNTING BRACKET	CALL FACTORY		X					
E18	EVAPORATOR COIL MOUNTING BRACKET	CALL FACTORY					X		

ALL MODELS:
EXCLUDING 51386, 51395
& PASS THRU UNITS

Electrical Schematic

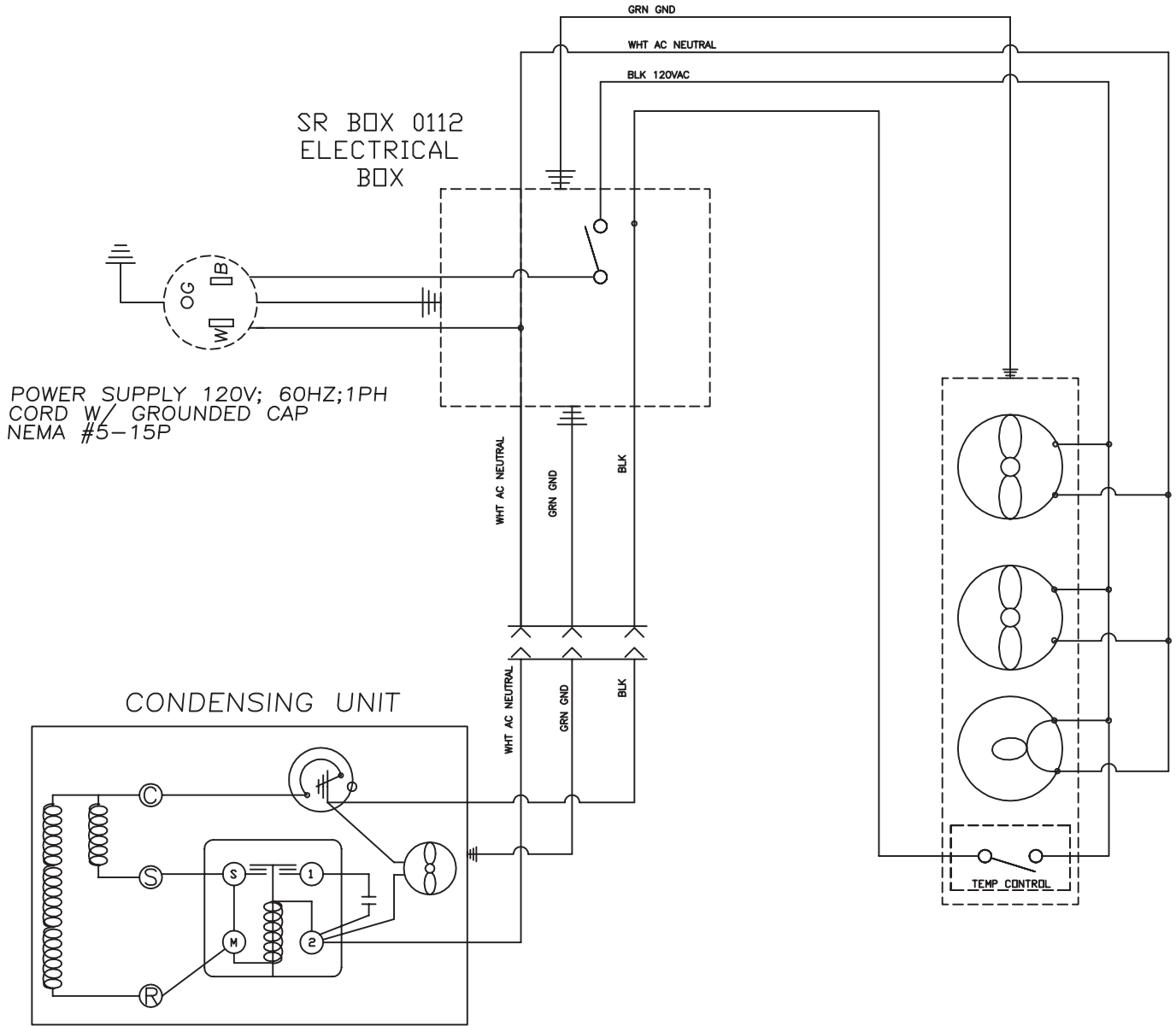

MODELS:
51386 & 51395

Electrical Schematic

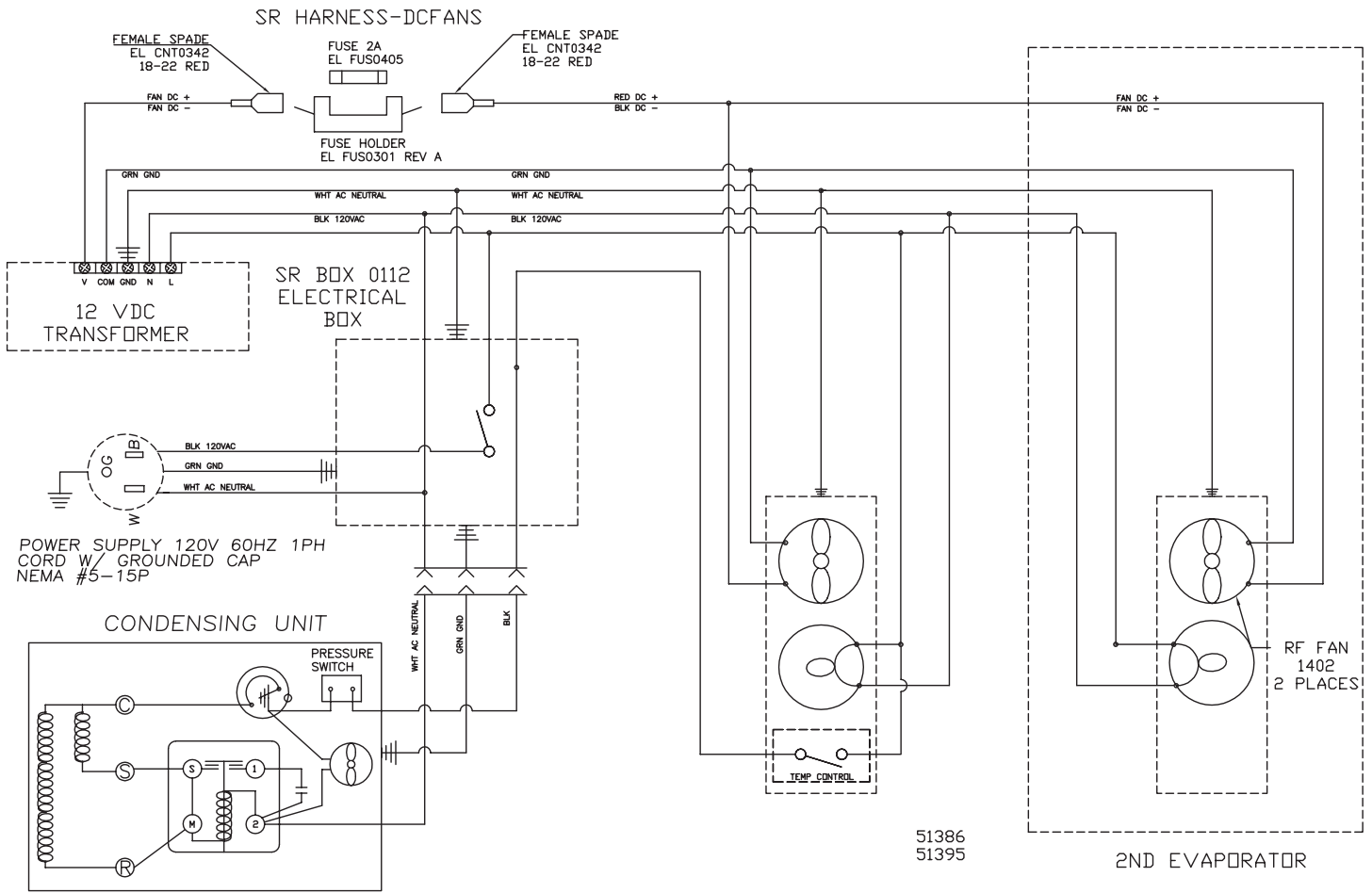

ALL PASS THRU MODELS:
51347PT-35 / -52 & 51368PT-35 / -52

Electrical Schematic

