



OPERATOR MANUAL

IMPORTANT INFORMATION, KEEP FOR OPERATOR

888-994-7636, fax 888-864-7636
randell.com

THIS MANUAL MUST BE RETAINED FOR FUTURE REFERENCE. READ, UNDERSTAND AND FOLLOW THE INSTRUCTIONS AND WARNINGS CONTAINED IN THIS MANUAL.

FOR YOUR SAFETY Do not store or use gasoline or other flammable vapors and liquids in the vicinity of this or any other appliance.

NOTIFY CARRIER OF DAMAGE AT ONCE It is the responsibility of the consignee to inspect the container upon receipt of same and to determine the possibility of any damage, including concealed damage. Randell suggests that if you are suspicious of damage to make a notation on the delivery receipt. It will be the responsibility of the consignee to file a claim with the carrier. We recommend that you do so at once.

Manufacture Service/Questions 888-994-7636.

This manual provides information for:

DPTSK SERIES INTEGRATED WEIGH SCALE KIT

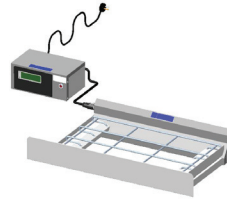

RETAIN THIS MANUAL FOR FUTURE REFERENCE

NOTICE: Due to a continuous program of product improvement, Randell reserves the right to make changes in design and specifications without prior notice.

NOTICE: Please read the entire manual carefully before installation. If certain recommended procedures are not followed, warranty claims will be denied.

MODEL NUMBER _____

SERIAL NUMBER _____

INSTALLATION DATE _____

The serial number is located on the back of the control box. An example is shown here.

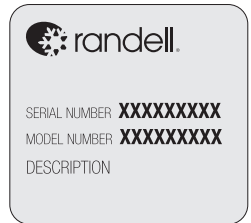

EQUIPMENT DESCRIPTION

MODEL	SCALE PLATFORM			SCALE DISPLAY CONTROL			VOLT	AMPS	NEMA	SHIP WT.
	L	D	H	L	D	H				
DPTSK	29.8"	18"	5"	10"	6"	4.5"	115/60/1	1	5-15P	40



Information contained in this document is known to be current and accurate at the time of printing/creation. Reference our product line website for the most updated product information and specifications. © 2026 Electrolux Professional, Inc. All Rights Reserved.

INSTALLATION

WARNING: FAILURE TO FOLLOW INSTALLATION GUIDELINES AND RECOMMENDATIONS MAY VOID THE WARRANTY ON YOUR UNIT.

INSTALLATION CHECKLIST

After the final location has been determined, refer to the following checklist prior to start-up:

1. Integrated Scale Platform parts lists: (Illustration 1)
(1) Scale Platform, (1) Control Box with Power Cord & Cord to Platform, (1) Stainless Steel Wire Grate, (2) Wire Grate Brackets

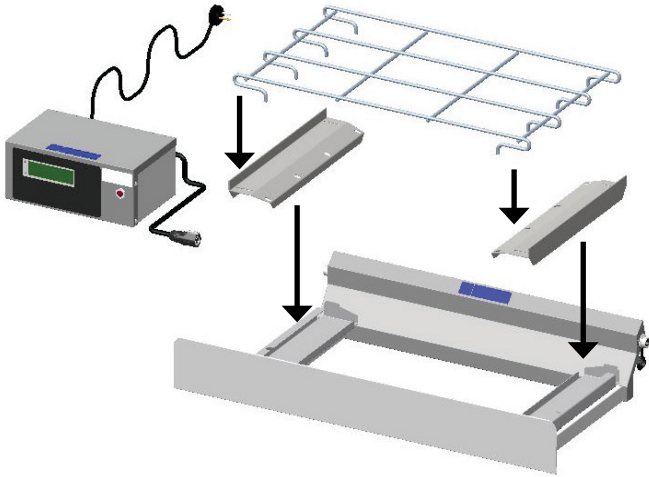

2. Refer to the front of this manual for serial number location. Please record this information in your manual on page 1 now. It will be necessary when ordering replacement parts or requesting warranty service.

ELECTRICAL SUPPLY

The wiring should be done by a qualified electrician in accordance with local electrical codes. A properly wired and grounded outlet will assure proper operation. Supply voltage and amperage requirements are located on the serial number tag on the back of the display control box.

INSTALLATION INSTRUCTIONS

1. Determine the location left or right that the cheesing operation will be completed. The Scale Platform is designed with (2) Receptacles one on each side. If the Scale Platform is placed on the left of the preparation table the left receptacle will be used. If on the right the right receptacle is used.



Scale Platform for left to right operation

2. Remove existing grate and install Scale Platform into the refrigerated catch pan work surface.

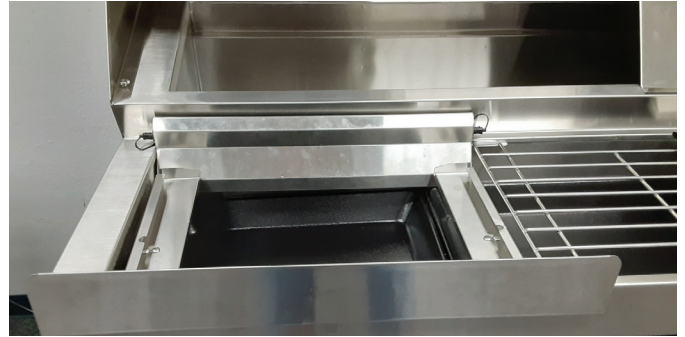

3. Remove dust cap from receptacle.



4. The Scale Plug and Power Cord exits from the back of the Control Box.



Scale plug



Power cord

5. Plug in the Platform Plug/Cord into the Receptacle. Line up the plug latch to the receptacle catch as shown and push until it clicks into place.



Align latch and catch, push to "click".

6. Control Box may be placed on the work surface of the adjacent work table or on top of the hood cover if one is provided.

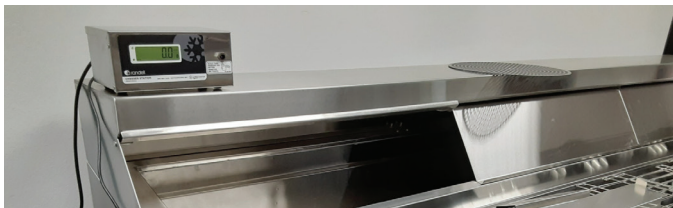

Control box on hood cover

7. Plug in Power Cord into the 120V receptacle.
8. Weight Display on the Control Box will display several start up configurations and then indicate "0.0". The Scale Platform is ready to use.



OPERATION

INTEGRATED WEIGHT SCALE KIT

1. Assure all the parts are placed on the Scale Platform with the Wire Grate brackets sitting securely on the locating mounting bars.

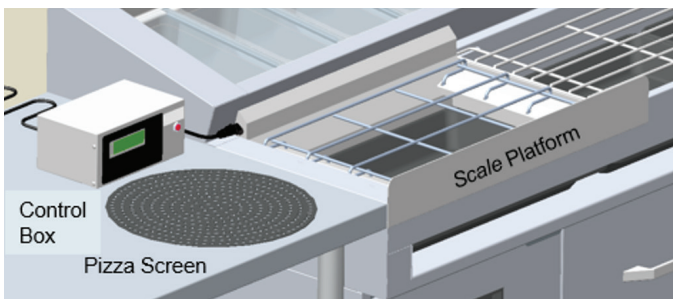

2. Route Platform Cord to the Control Box away from work area.

3. Prepare flattened dough on pizza pan or screen and sauce on work surface area as shown in #1.

4. Move pizza to the right (or left in right to left operations) so that the pizza is fully on the wire grate. Make sure the pizza and pan/screen does not touch the front or back walls of the Scale Platform to assure accurate weight results.

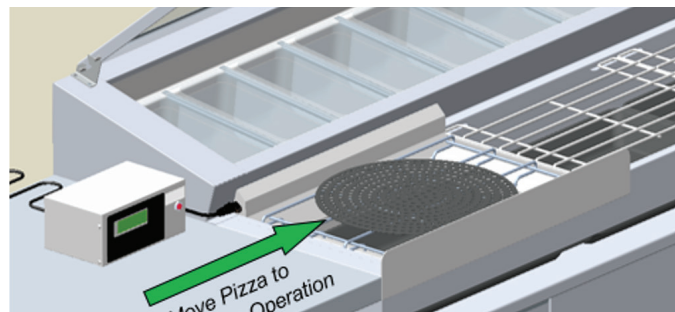

5. Tare the weight to "0.0" by waving hand approximately 3" in front of sensor located on the front of the Control Box. The sensor does not need to be touched.



6. Apply the cheese to the proper weight requirements as indicated on the Weight Indicator Display.

7. Move the pizza to the next topping operation.

8. Repeat steps 3-7.

PHOTO-SENSOR ADJUSTMENT

WARNING: THE CONTROL BOX CONTAINS ELECTRICAL WIRING AND SHOULD BE ONLY OPENED BY A QUALIFIED ELECTRICIAN.

1. Open front cover of the control box by removing (6) screws as shown below.

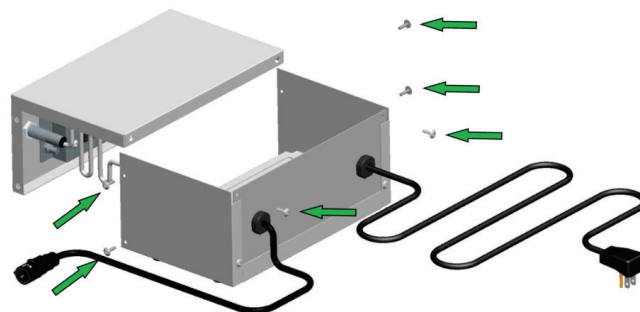

2. Control must be energized to adjust tare distance of the photo-sensor.
3. Locate sensor on the right side of control box front cover.

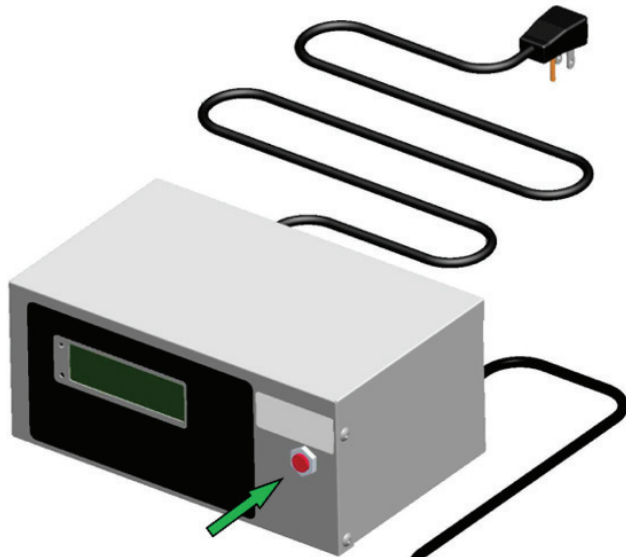

MAINTENANCE

WARNING: DO NOT USE SHARP UTENSILS AND/OR OBJECTS.

WARNING: DO NOT USE STEEL PADS, WIRE BRUSHES, SCRAPERS, OR CHLORIDE CLEANERS TO CLEAN YOUR STAINLESS STEEL.

CAUTION: DO NOT USE ABRASIVE CLEANING SOLVENTS, AND NEVER USE HYDROCHLORIC ACID (MURIATIC ACID) ON STAINLESS STEEL.

WARNING: DO NOT PRESSURE WASH EQUIPMENT AS DAMAGE TO ELECTRICAL COMPONENTS MAY RESULT.

REQUIRED DAILY CLEANING INSTRUCTIONS

If a failure of the equipment is a direct result of any of the Required Daily Cleaning Instruction guidelines being neglected, the repairs and parts replacements will not be covered under warranty.

1. Remove Wire Grate and Brackets from the Scale Platform. Wash these items in the wash sink.

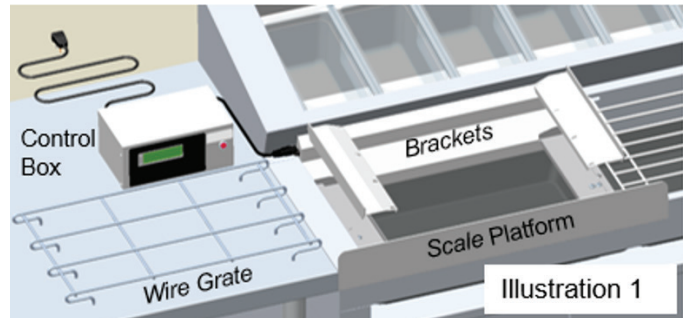

2. Disconnect the Platform Cord from the Receptacle on the Scale Platform.
 - Push down on the latch of the scale plug/cord. The latch is marked “push”.
 - Pull gently away from receptacle to un-plug.
 - Install dust cap on receptacle when not in use.



3. Lift Scale Platform out of refrigerated catch pan area and place on work surface adjacent to the Makeline.

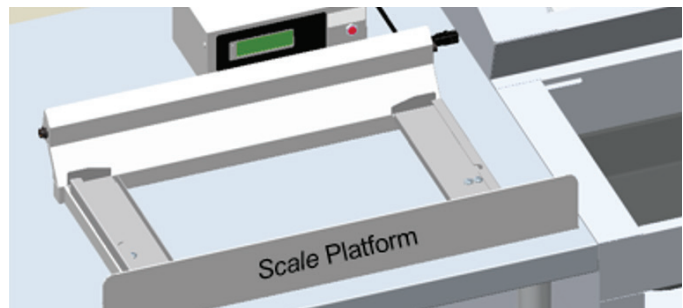

4. Clean the Scale Platform and Control Box with a clean damp cloth and Sanitize. DO NOT SUBMERSE THESE PARTS IN WATER.

4. Behind the front cover, locate the back of the photo-sensor. When you wave your hand in front of the photo-sensor you will see (2) lights.
5. Located towards the cord is the set button. Press this button and hold your hand at the desired tare activation distance in front of the photo-sensor for about 4-5 seconds.



6. Test the tare distance by waving your hand in front of the photo-sensor to make sure it is at the distance required.
7. Re-install front cover of control box.

- Cleaning between the Wire Grate Bracket locating bars can be accomplished by inserting a clean damp cloth as shown in below. Complete this cleaning action from the back as shown and then the front.

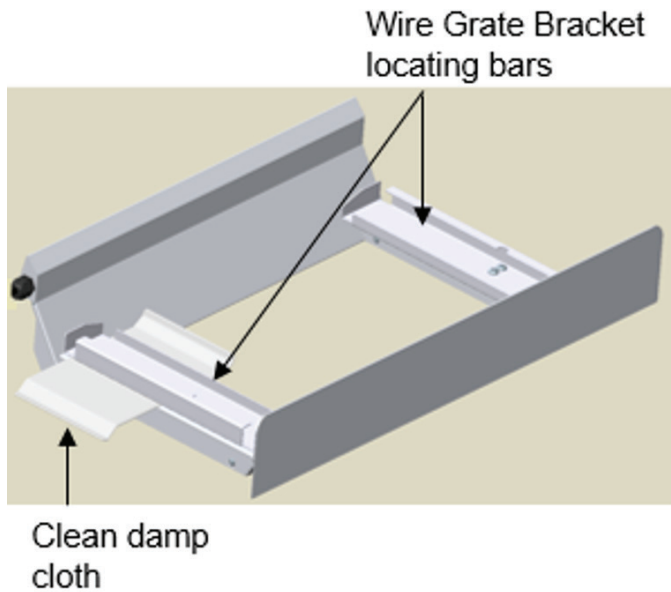

SERVICE

CAUTION: COMPONENT PARTS SHALL BE REPLACED WITH FACTORY OEM PARTS. SERVICE WORK SHALL BE DONE BY FACTORY AUTHORIZED SERVICE PERSONNEL.

CAUTION: BEFORE MAKING ANY REPAIRS, ENSURE THE UNIT IS DISCONNECTED FROM ITS POWER SOURCE.

Randell believes strongly in the products it manufactures and backs those products with one of the best warranties in the industry. We believe with the proper cleaning maintenance and use, you will realize a profitable return on your investment and years of satisfied service.

REPLACEMENT PARTS

To order parts, contact your Authorized Service Agent. Supply the model designation, serial number, part description, part number, quantity, and when applicable, voltage and phase.

CONTACT US

If you have questions pertaining to the content in this manual, contact Randell at 888-994-7636.

TROUBLESHOOTING

This unit is designed to operate smoothly and efficiently if properly maintained. However, the following is a list of checks to make in the event of a problem. Wiring diagrams are found at the end of this manual. When in doubt, turn unit off and contact service at 888-994-7636.

SYMPTOM	POSSIBLE CAUSE	PROCEDURE
Unit does not run	No power to unit	Plug in unit
	Faulty control	Call for service at 888-994-7636
Display is blank	No power to unit	Plug in unit
	Faulty control	Call for service at 888-994-7636
Weight shown on display is not accurate	Wire grate and grate brackets are installed incorrectly	Reinstall rack brackets and wire rack so that those parts are not touching other parts of the scale platform
	Food particles between the wire grate bracket locating bars	Remove wire grate and brackets and clean between the locating bars and support bars as shown in the Maintenance section of this manual
	Faulty control	Call for service at 888-994-7636
Weight shown on display is fluctuating and does not show a specific weight	Wire grate and grate brackets are installed incorrectly	Reinstall rack brackets and wire rack so that those parts are not touching other parts of the scale platform
	Food particles between the wire grate bracket locating bars	Remove wire grate and brackets and clean between the locating bars and support bars as shown in the Maintenance section of this manual
	Faulty control	Call for service at 888-994-7636

ELECTRICAL BOX

CALL FACTORY FOR REPLACEMENT PARTS:
888-994-7636

Parts List

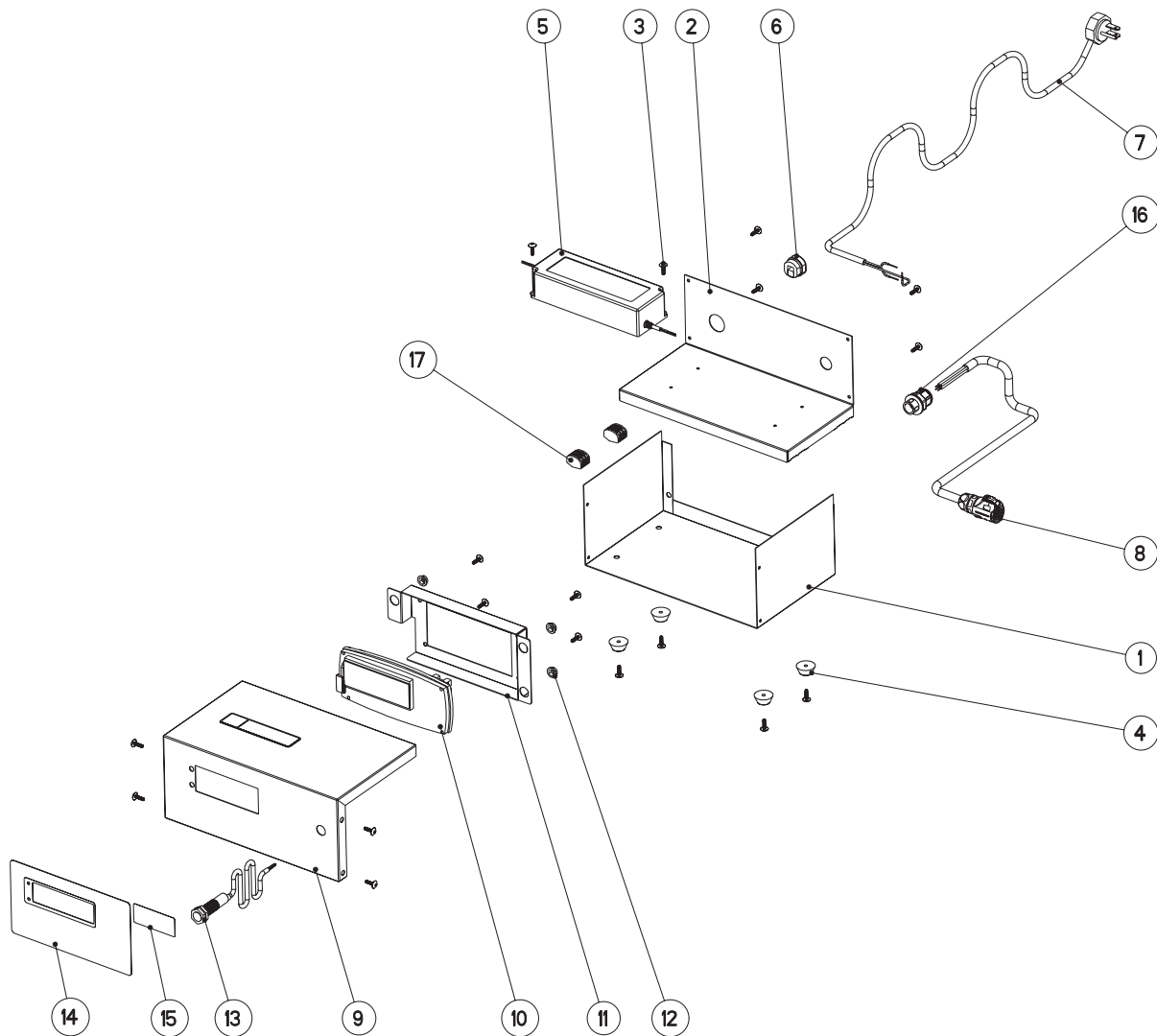

ITEM	QUANTITY	SERVICE PART	DESCRIPTION
P	1	DO SCL2002	CONTROL BOX, SCALE PLATFORM ASSEMBLY
1	1	DO SCL2012	PANEL, CONTROL BOX
2	1	DO SCL2011	BRACKET, MOUNTING CONTROL TRANSFORMER
3	18	FA BLT2040	BOLT, 8-32X1/2 T/H/P "F" 410 GKXJ PHILLIPS TRUSS STAINLESS
4	4	HD BMP010	BUMPER, RECESSED RUBBER Q20-2095
5	1	EL TRN1801	TRANSFORMER, 90W CONSTANT VOLTAGE, CURRENT CLASS 2 LPF-90-24
6	1	EL GRM300	GROMMET, 7/8" BLK SQUEEZE RD SR7K-2 (MP-MP07K20) 1240 N*
7	1	EL WIR1703	POWER CORD, 9' 16/3 W/90*-45* ANGLE PLUG (SJTO WIRE)
8	1	EL PLG2101	PLUG, CIRCULAR CONNECTOR 4 SOCKET 16IN 18/4 SJE00W CORD
9	1	DO SCL2010	PANEL, CONTROL
10	1	EL SCL2001	SCALE CONTROL DISPLAY BOARD W/TERMINATION CONNECTOR
11	1	DO SCL2013	BRACKET, WEIGH SCALE DISPLAY BOARD
12	3	FA NUT0305	NUT, 10-24 SHEET METAL SPEED Q32-1024
13	1	EL SEN1801	SENSOR, PHOTOELECTRIC SWITCH 12M CYLINDRICAL DC 10-30V DATA
14	1	PP LBL1813	LABEL, CONTROL-DISPLAY SCALE
15	1	PP LBL1956	LABEL, SCALE TARE SENSOR 1X3 UNIVERSAL
16	1	EL GRM2101	GROMMET, CABLE GLAND BLACK 5-9MM WIRE SNAP-IN HOLE 16.3MM
17	2	EL CNT1803	CONNECTOR,SPLICE, WAGO 222-413, 3-WIRE

SCALE PLATFORM

CALL FACTORY FOR REPLACEMENT PARTS:
888-994-7636

Parts List

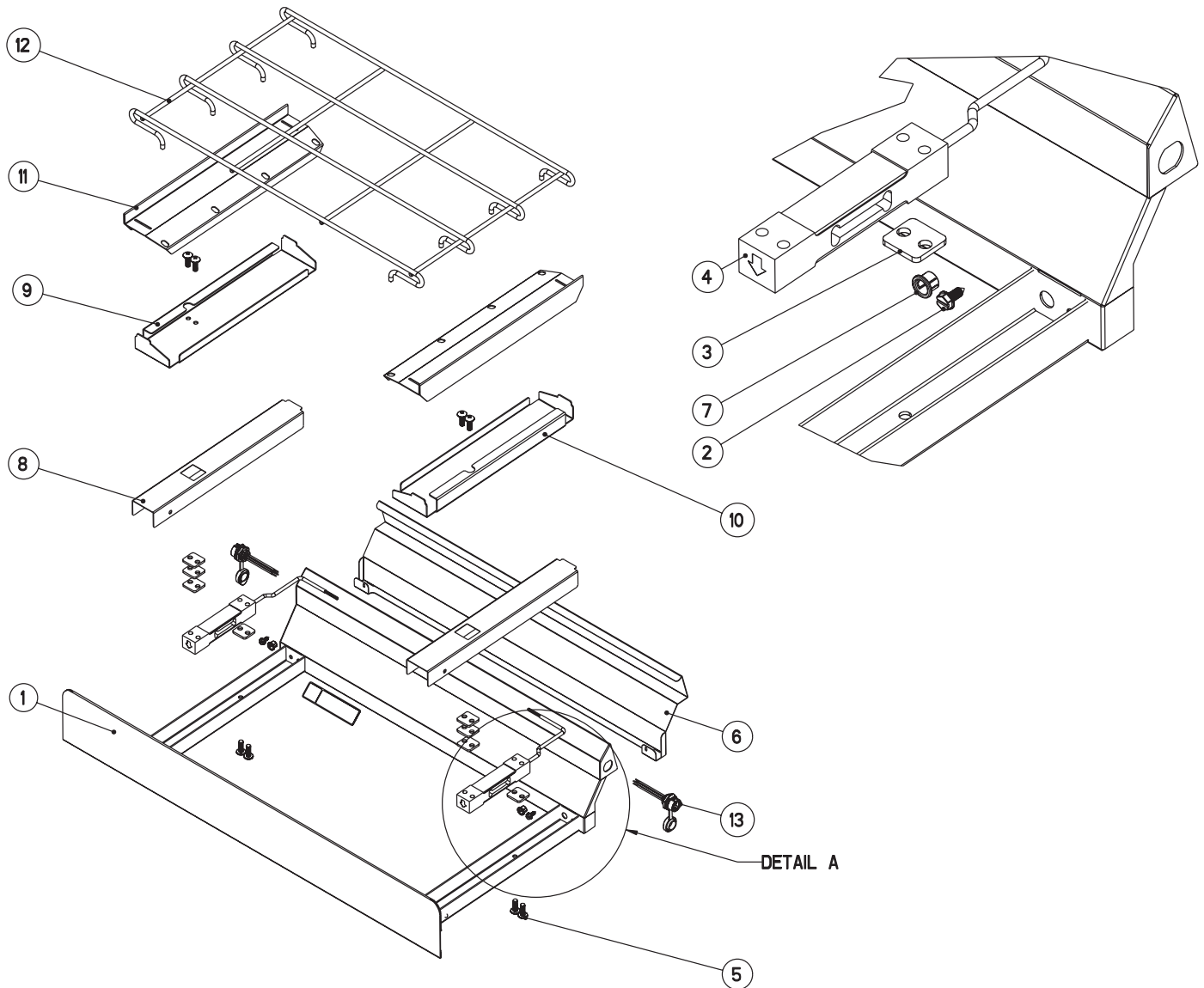

ITEM	QUANTITY	SERVICE PART	DESCRIPTION
P	1	DO SCL2001	SCALE PLATFORM ASSEMBLY
1	1	DO SCL2003	SCALE PLATFORM WELDED ASSEMBLY ONLY
2	2	EL GRM050	GROMMET, 1/2" HOLE BLACK
3	6	DO SCL2004	SPACER PLATE
4	2	EL SCL2301	SCALE, WEIGH SENSOR LAUMAS - AFTER DEC 2023
4	2	EL SCL1802	SCALE, WEIGH SENSOR GERHART
5	8	FA BLT0106	BOLT, 1/4-20 X 3/4 T/H/P 18-8 M6KF WITH LIGHT NYLON PATCH
6	1	DO SCL2005	COVER, CHASE SCALE BACK
7	2	FA SCW3045	SCREW, 10X1/2"HWH TYP A 410 10X1/2" SLOTTED HWH 410 SS
8	2	DO SCL2006	CAP SCALE LOAD CELL BRACKET
9	1	DO SCL2007	MOUNTING SCALE BRACKET, LEFT
10	1	DO SCL2008	MOUNTING SCALE BRACKET, RIGHT
11	1	DO SCL2009	MOUNTING BRACKET, RACK
12	1	HD RCK1903	RACK, SS PREP 23.25" X 13" X 0.25" ROD
13	2	EL REC2101	RECEPTACLE, 4 PIN MALE 24 IN 18 GA WIRE LEADS

Wiring Diagram

