

SEPARATED-COMBUSTION DUCT FURNACE INSTALLATION, OPERATION, AND MAINTENANCE

MODEL SC



⚠ DANGER ⚠

FIRE OR EXPLOSION HAZARD

- Failure to follow safety warnings exactly could result in serious injury, death, or property damage.
- Improper installation, adjustment, alteration, service, or maintenance can cause serious injury, death, or property damage.
- Installation and service must be performed by a qualified installer, service agency, or the gas supplier.
- Be sure to read and understand the installation, operation, and service instructions in this manual.
- Do not store or use gasoline or other flammable vapors and liquids in the vicinity of this or any other appliance.

WHAT TO DO IF YOU SMELL GAS

- Do not try to light any appliance.
- Do not touch any electrical switch; do not use any phone in your building.
- Leave the building immediately.
- Immediately call your gas supplier from a phone remote from the building. Follow the gas supplier's instructions.
- If you cannot reach your gas supplier, call the fire department.

DO NOT DESTROY. PLEASE READ CAREFULLY. KEEP IN A SAFE PLACE FOR FUTURE REFERENCE.

TABLE OF CONTENTS

GENERAL INFORMATION	3
References	3
Important Safety Information	4
Separated Combustion	4
Installation Codes	5
Special Installations (Aircraft Hangars/Garages)	5
Warranty	5
Dimensions	5
Weights	7
Clearances	7
Location	7
Hazards of Chlorine	7
INSTALLATION	8
Uncrating/Unpacking	8
Shipped-Separate Parts	8
Reversing Airflow by Changing Direction of Heat Exchanger Air Baffles	9
Suspension	9
Mounting	10
Duct Connections	11
Requirements and Suggestions for Connecting and Installing Ducts	11
Discharge Air Temperature Sensor Installation	12
Duct Furnace Airflow	15
Field-Supplied Blower Connections	15
Bypass Duct Construction	17
Venting/Combustion Air Connections	18
Specific Venting Requirements: Piping	18
Specific Venting Requirements: Venter Outlet and Combustion Air Inlet Connections	19
Specific Venting Requirements: Joints and Sealing	19
Specific Venting Requirements: Support	20
Specific Venting Requirements: Clearance	20
Specific Venting Requirements: Concentric Adapter Box	20
Specific Venting Requirements: Concentric Adapter Box Pipe Connections	21
Vent Terminal Options	22
Vertical Vent Terminal (Option CC2) Installation	23
Horizontal Vent Terminal (Option CC6) Installation	28
Piping Connections	32
Gas Supply Pressure	32
Gas Supply Piping	33
Supply Piping Connections	33
Condensate Drain Installation	34
Electrical Connections	35
Control Wiring	35
CONTROLS	36
Thermostat	36
Combustion Air Proving Switch	36
Blower Fan Control	37
Limit Control	37
Variable Frequency Drive	37
Combination Gas Valve	37
Optional Two-Stage Control (Heating Only Application)	37
Optional Two-Stage Control (Makeup Air Application)	38
Optional Ductstat with Capillary Tubing (Option AG3)	38
Optional Ductstat with Electronic Remote Setpoint Module (Option AG15)	39

TABLE OF CONTENTS—CONTINUED

Optional Electronic Modulation	39
Electronic Modulation Between 50% and 100% Firing Rate (Option AG7, AG8, or AG9)	39
Computer-Controlled Electronic Modulation Between 50% and 100% Firing Rate (Option AG21)	40
Electronic Modulation Between 20–28% and 100% Firing Rate (Option AG39)	40
Electronic Modulation Between 20–28% and 100% Firing Rate (Option AG40)	41
Pilot and Ignition Systems	43
Burners, Burner Orifices, and Carryover System	43
OPERATION	44
Pre-Startup Checklist	44
Startup	45
Post-Startup Checklist	46
ADJUSTMENTS	46
Measure and Adjust Manifold (Outlet) Gas Pressure	46
High Elevation (>2,000 Feet/609 Meters) Installations	47
Conversion to LP (Propane)	49
Burner Air Shutter Adjustment	49
MAINTENANCE	49
Service Checklist	50
Maintenance Procedures	50
Combination Gas Valve Maintenance	50
Vent/Combustion Air System Maintenance	51
Burner Rack Maintenance	51
Cleaning Pilot and Burners	52
Spark Ignition System Maintenance	53
Cleaning Heat Exchanger	54
Venter Motor Maintenance	54
TROUBLESHOOTING	54
INSTALLATION RECORD (TO BE COMPLETED BY INSTALLER)	56

GENERAL INFORMATION

- This unit has been tested for capacity and efficiency so as to provide many years of safe and dependable comfort providing it is properly installed and maintained. With regular maintenance, this unit will operate satisfactorily year after year. Abuse, improper use, and/or improper maintenance can shorten the life of the appliance and create unsafe hazards.
- To achieve optimum performance and minimize equipment failure, it is recommended that periodic maintenance be performed on this unit. The ability to properly perform maintenance on this equipment requires certain tools and mechanical skills.
- The indoor duct furnace models in this manual are design-certified to ANSI and CSA standards by the Canadian Standards Association. All models are approved for installation in the United States and in Canada. All furnaces are approved for use with either natural gas or propane. The type of gas for which the furnace is equipped and the correct firing rate are shown on the rating plate attached to the unit. Electrical characteristics are shown on the unit rating plate.

References

Table 1. Related Technical Manuals Available from Factory Distributor

Type	Form*	PN
Replacement parts	SC-SCE-SSCBL-SSCDBL-RPL	269822
Vent/combustion air kit installation	OPT-CC2-CC6	205892
Maxitrol amplifier replacement kit installation	OPT-AG7,8,9,9H	262319
Ignition controller replacement kit installation	OPT-IGN-CNTRL	134704
Gas conversion	OPT-GC	143147

*Also available at www.reznorhvac.com.

GENERAL INFORMATION—CONTINUED

Important Safety Information

Please read all information in this manual thoroughly and become familiar with the capabilities and use of your appliance before attempting to operate or maintain this unit. Pay attention to all dangers, warnings, cautions, and notes highlighted in this manual. Safety markings should not be ignored and are used frequently throughout to designate a degree or level of seriousness.

DANGER: A danger statement describes a potentially hazardous situation that if not avoided, will result in severe personal injury or death and/or property damage.

WARNING: A warning statement describes a potentially hazardous situation that if not avoided, can result in severe personal injury and/or property damage.

CAUTION: A caution statement describes a potentially hazardous situation that if not avoided, can result in minor or moderate personal injury and/or property damage.

NOTE: A note provides important information that should not be ignored.

DANGER

Gas-fired appliances are not designed for use in hazardous atmospheres containing flammable vapors or combustible dust, in atmospheres containing chlorinated or halogenated hydrocarbons, or in applications with airborne silicone substances.

WARNING

For your safety, read the warning labels on the unit.

NOTES:

- **Installation should be done by a qualified agency in accordance with the instructions in this manual and in compliance with all codes and requirements of authorities having jurisdiction.**
- **The instructions in this manual apply only to model SC duct furnaces.**
- **Model SC units are not certified as residential heating equipment and should not be used as such.**

Separated Combustion

- This separated-combustion unit is designed and manufactured in accordance with the ANSI definition of separated combustion, which reads, “Separated Combustion System Appliance: A system consisting of an appliance and a vent cap(s) supplied by the manufacturer, and (1) combustion air connections between the appliance and the outside atmosphere, and (2) flue gas connections between the appliance and vent cap, of a type(s) specified by the manufacturer but supplied by the installer, constructed so that, when installed in accordance with the manufacturer’s instructions, air for combustion is obtained from the outside atmosphere and flue gases are discharged to the outside atmosphere.”
- Separated-combustion units are designed to separate air for combustion and flue products from the environment of the building in which the unit is installed. Separated-combustion appliances are recommended for use in dust-laden and some corrosive-fume environments.

Installation Codes

- These units must be installed in accordance with local building codes. In the absence of local codes, in the United States, the unit must be installed in accordance with the *National Fuel Gas Code* NFPA/ANSI Z223.1 (latest edition). A Canadian installation must be in accordance with the *CSA B149.1 Natural Gas and Propane Installation Code*. This code is available from CSA Information Services, 1-800-463-6727. Local authorities having jurisdiction should be consulted before installation is made to verify local codes and installation procedure requirements.
- These gas-fired products are certified by ANSI Z83 family of standards governing the safe usage of heating equipment in the industrial/commercial marketplace. This includes using the heaters in makeup air applications to supply corridor pressurization in commercial buildings such as office structures and apartment complexes.
- The heaters are not certified as residential heating equipment and should not be used as such.
- Clearances from the heater and vent to combustible construction or material in storage must conform with the *National Fuel Gas Code* ANSI Z223.1 (latest edition) pertaining to gas-burning devices, and such material must not attain a temperature over 160°F (71°C) by continued operation of the heater.

Special Installations (Aircraft Hangars/Garages)

Installations in aircraft hangars should be in accordance with NFPA No. 409 (latest edition), *Standard for Aircraft Hangars*, in public garages in accordance with NFPA No. 88A (latest edition), *Standard for Parking Structures*, and for repair garages in accordance with NFPA No. 88B (latest edition), *Standard for Repair Garages*. In Canada, installations in aircraft hangars, repair garages, and parking garages should be in accordance with the requirements of the enforcing authorities and in accordance with CSA B149 codes.

Warranty

NOTE: These duct furnaces are not certified or approved for use in drying or process applications. If a duct furnace is to be used in a drying or process application, contact the factory for application guidelines and manufacturer's authorization. Without factory authorization, the warranty is void, and the manufacturer disclaims any responsibility for the duct furnace and/or the application.

Refer to the limited warranty information on the warranty card in the owner's envelope. Warranty is void if:

- a. Separated-combustion heaters are used in atmospheres containing flammable vapors or atmospheres containing chlorinated or halogenated hydrocarbons or any contaminant (silicone, aluminum oxide, etc.) that adheres to the spark ignition flame sensing probe.
- b. Wiring is not in accordance with the diagram furnished with the heater.
- c. Unit is installed without proper clearance to combustible materials.
- d. Furnace air throughput is not adjusted within the range specified on the rating plate.
- e. Duct furnace is installed in a process or drying application without factory authorization. Any use in a process or drying application voids agency certification.

GENERAL INFORMATION—CONTINUED

Dimensions

NOTES:

Inches (mm)

Standard airflow may be reversed by changing direction of heat exchanger air baffles.

Burner and control access shown left-hand side. Specify right-hand side for opposite access and connections.

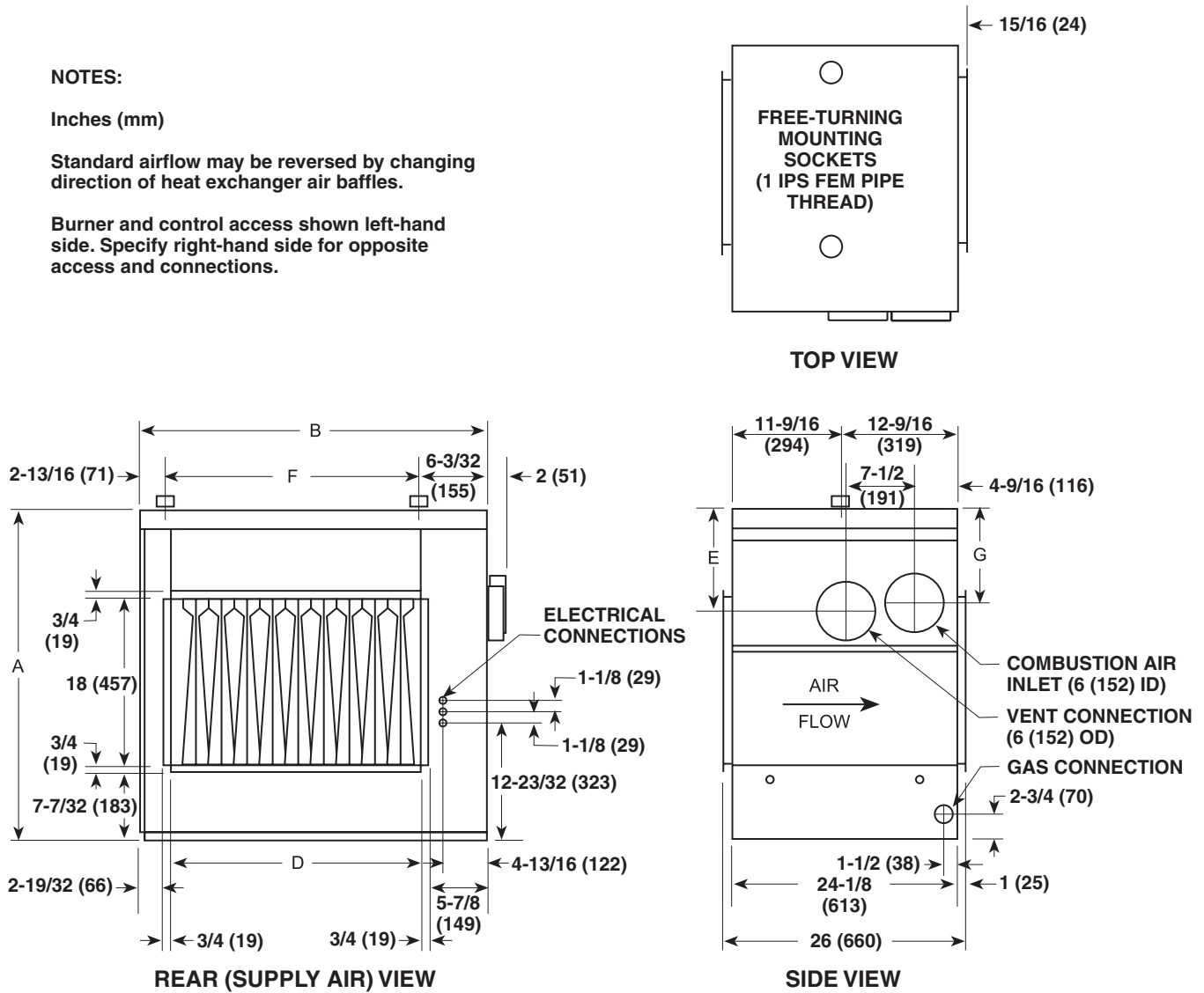

Figure 1. Dimensions (Refer to Table 2)

Table 2. Dimensions							
Dimension (See Figure 1)	Unit Size						
	100	125	150, 175	200, 225	250, 300	350	400
	Inches (mm)						
A	32-1/4 (819)			35-1/4 (895)			
B	22-15/32 (571)	25-7/32 (641)	30-23/32 (780)	36-7/32 (920)	44-15/32 (1130)	49-31/32 (1269)	55-15/32 (1409)
D	12-1/2 (318)	15-1/4 (387)	20-3/4 (527)	26-1/4 (667)	34-1/2 (876)	40 (1016)	45-1/2 (1156)
E	8-1/8 (206)			10-3/4 (273)			
F	13-9/16 (344)	16-15/16 (430)	21-13/16 (554)	27-5/16 (694)	35-9/16 (903)	41-1/16 (1043)	46-9/16 (1183)
G	6-15/16 (176)			9-15/16 (252)			

Weights

Unit Size						
100	125	150, 175	200, 225	250, 300	350	400
Net Weight (Pounds (kg))						
158 (72)	178 (81)	203 (92)	283 (128)	321 (146)	350 (159)	410 (186)

Clearances

Clearance to combustibles is defined as the minimum distance—from the heater to a surface or object—that is necessary to ensure that a surface temperature of 90°F (50°C) above the surrounding ambient temperature is not exceeded. For safety and convenience, ensure that the clearances listed in **Table 4** are provided. Minimum clearances are also listed on the heater rating plate.

Unit Surface	Minimum Clearance (Inches (mm))
Top	6 (152)
Control side	6 (152) + width of unit
Side opposite controls	6 (152)
Bottom, to combustibles	6 (152)
Bottom, to noncombustibles	0 (0)

Location

⚠ CAUTION ⚠

Do not locate the unit where it may be exposed to water spray, rain, or dripping water.

- A duct furnace is designed for connection to an inlet and an outlet duct and depends on an external air handler. The location must comply with the clearances listed in **Table 4**. There are a variety of factors, such as system application, building structure, dimensions, and weight, that contribute to selecting the location. Read the installation information in this manual and select a location that complies with the requirements.
- For best results, the heater should be placed with certain rules in mind. In general, a unit should be located from 8–12 feet (2.6–3.6 meters) above the floor. Units should always be arranged to blow toward or along exposed wall surfaces, if possible. Where two or more units are installed in the same room, a general scheme of air circulation should be maintained.
- Suspended heaters are most effective when located as close to the working zone as possible, and this fact should be kept in mind when determining the mounting heights to be used. However, avoid directing the discharged air directly on the room occupants.
- Partitions, columns, counters, or other obstructions should be taken into consideration when locating the unit heater, so that a minimum quantity of airflow will be deflected by such obstacles. When units are located in the center of the space to be heated, the air should be discharged toward the exposed walls. In large areas, units should be located to discharge air along exposed walls with extra units provided to discharge air in toward the center of the area.
- At those points where infiltration of cold air is excessive, such as at entrance doors and shipping doors, it is desirable to locate the unit so that it will discharge directly toward the source of cold air from a distance of 15–20 feet (4.5–6 meters).

Hazards of Chlorine

⚠ WARNING ⚠

SC series separated-combustion units are not designed or approved for use in atmospheres containing flammable vapors or atmospheres highly-laden with chlorinated vapors.

GENERAL INFORMATION—CONTINUED

Hazards of Chlorine—Continued

NOTE: Remember, chlorine is heavier than air. This fact should be kept in mind when determining the installation location of heaters and building exhaust systems.

The presence of chlorine vapors in the combustion air of heating equipment presents a potential corrosion hazard. Chlorine, found usually in the form of Freon or degreaser vapors, when exposed to flame will precipitate from the compound and form a solution with any condensation present in the heat exchanger or associated parts. The result is hydrochloric acid, which readily attacks all metals, including 300 grade stainless steel. Care should be taken to separate these vapors from the combustion process. This may be done by wise location of the unit with regard to exhausters or prevailing wind directions.

INSTALLATION

NOTE: Before installation, make preparations for necessary supplies, tools, and manpower.

Uncrating/Unpacking

- Immediately upon uncrating, check the gas specifications and electrical characteristics on the unit's rating plate to be sure that they agree with the gas and electric supply at the installation site.
- The furnace was test-operated and inspected at the factory prior to crating and was in operating condition. Check the unit for any damage that may have been incurred during shipment. If damage is found, document the damage with the transporting agency and immediately contact your Distributor. If you are an authorized Distributor, follow the FOB freight policy procedures.

NOTE: After removing the shipping clips that fasten the unit to the crate, it is required that the bolts that attach the shipping clips be reinstalled for support.

- The bottom corners are fastened to the crate using angled shipping clips. Remove the bolts from the shipping clips and remove the clips. Reinstall the bolts on the heater legs to support the corner leg and the heater bottom.
- **Concentric adapter box:** The concentric adapter box assembly in the venting/combustion air kit (option CC2 or CC6) is required on all separated-combustion models. Ensure that the concentric adapter box carton is at the installation site (refer to parts list in [Table 11](#) or [Table 13](#)).

Shipped-Separate Parts

Some gas control options have parts that are either shipped loose—with the heater—or shipped separate. Before beginning installation, ensure that any shipped-separate parts ordered are available at the site. Shipped-separate options could include a shutoff valve, a condensate drain kit, a [thermostat](#), a remote console, a disconnect switch, or high-temperature vent sealing tape. Also, if your unit is equipped with any of the gas control options listed in [Table 5](#), ensure that these parts are available at the job site.

Table 5. Shipped-Separate Parts for Gas Control Options

Application	Option	Part(s)
Heating	AG7	Thermostat (PN 48033)
Makeup air	AG3	Control switch (PN 29054)
	AG8	Control switch (PN 29054); sensor and mixing tube (PN 48041)
	AG9	Control switch (PN 29054); remote temperature selector (PN 48042); sensor and mixing tube (PN 48041)
	AG15	Control switch (PN 29054); remote temperature selector (PN 115848); stage adder module (PN 115849); discharge air sensor holder (PN 115850); discharge air sensor holder bracket (PN 213612)
	AG39	Remote temperature selector (PN 174849); temperature sensor (PN 133228); mixing tube (PN 90323)

NOTE: If an optional remote console is ordered, the control switch and temperature selector may be mounted on the console.

Reversing Airflow by Changing Direction of Heat Exchanger Air Baffles

Duct furnaces are equipped with directional air baffles between the heat exchanger tubes. When facing the control compartment of the furnace, the standard direction of airflow is from left to right. Installations requiring direction of airflow from right to left when facing the control compartment will require repositioning the directional air baffles at the installation site. Change the position of the baffles as follows:

1. Remove A screws (see [Figure 2](#)) and lift each baffle slightly and slide forward, removing each baffle from heat exchanger.
2. Remove C screws (see [Figure 2](#)) and remove bottom baffle support and brackets from heat exchanger.
3. Remove B screws (see [Figure 2](#)) and remove top baffle support. Install top baffle support on opposite end of heat exchanger using B screws.
4. Re-install bottom baffle support and brackets on opposite end of heat exchanger using C screws.
5. Re-install each baffle using A screws.

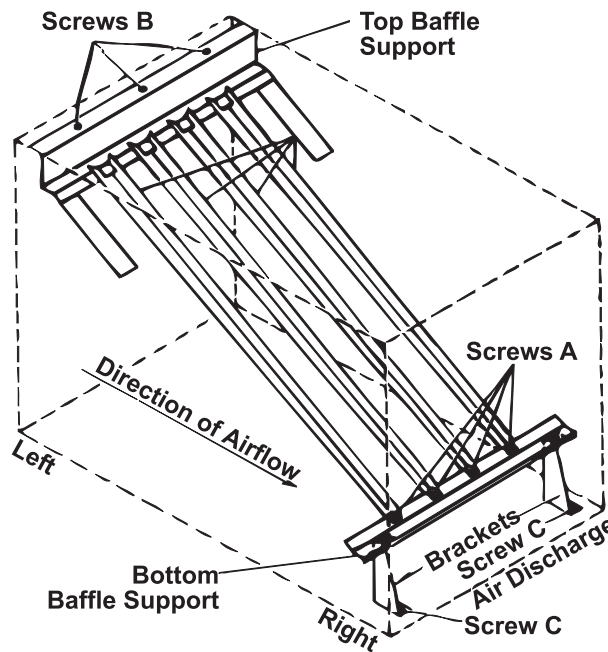

Figure 2. Heat Exchanger Air Baffles

Suspension

⚠ WARNING ⚠

- Before installation, check the supporting structure to ensure that it has sufficient load-carrying capacity to support the weight of the unit.
- Units must be level for proper operation. Do not place additional weight on or add additional weight to the suspended unit.

The unit has two-point suspension (see hanger center line dimensions shown in [Figure 1](#)). At each suspension point, the unit is factory-equipped with a free-turning, female, 1-inch NPT pipe hanger. Suspend the unit by connecting the pipe hanger to a 1-inch threaded pipe. See [Figure 2](#) for the standard and alternative suspension methods. The factory-installed pipe hanger may be removed and the heater may be suspended as shown in the right view of [Figure 2](#).

INSTALLATION—CONTINUED

Suspension—Continued

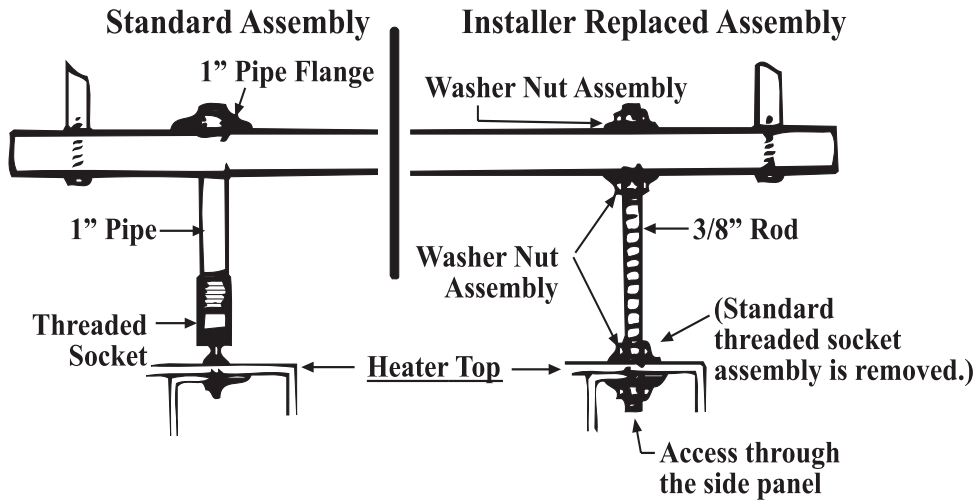

Figure 3. Suspension Methods

Mounting

Most furnaces will be suspended. If the installation requires the furnace to be mounted, see [Figure 4](#), which shows the requirements for field-fabricating support feet.

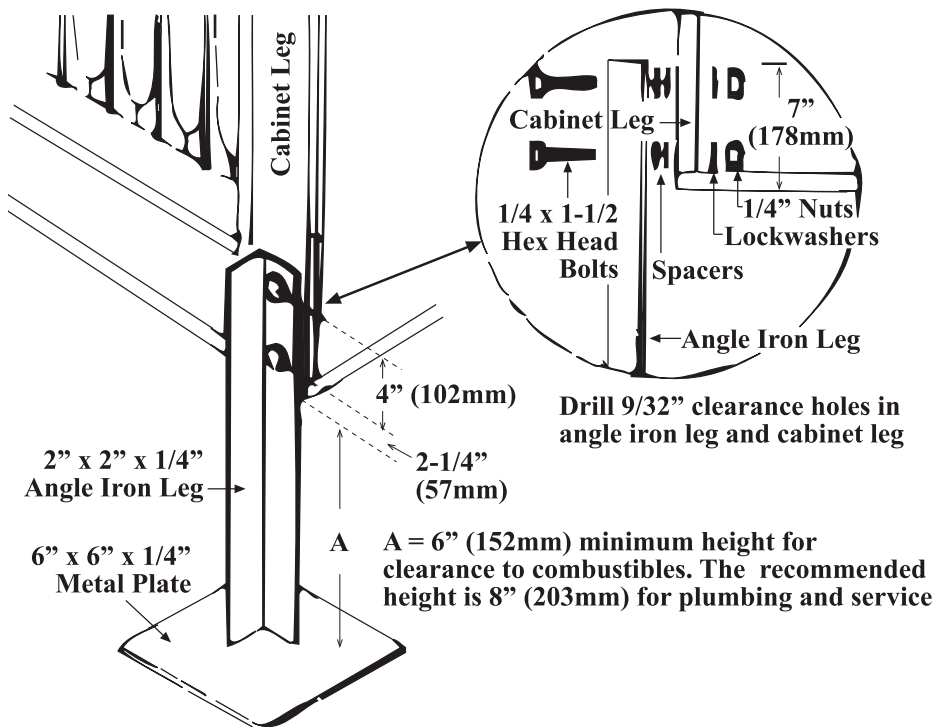

Figure 4. Corner Mounting Supports

Duct Connections

NOTE: Make adjustments to ductwork as necessary to obtain a temperature rise and static pressure within the ranges specified on the heater rating plate.

Refer to **Table 6** for duct connection dimensions.

Table 6. Duct Connection Dimensions						
Unit Size						
100	125	150, 175	200, 225	250, 300	350	400
Dimension G (Inches (mm))*						
12-1/2 (318)	15-1/4 (387)	20-3/4 (527)	26-1/4 (667)	34-1/2 (876)	40 (1016)	45-1/2 (1156)

*See **Figure 5**.

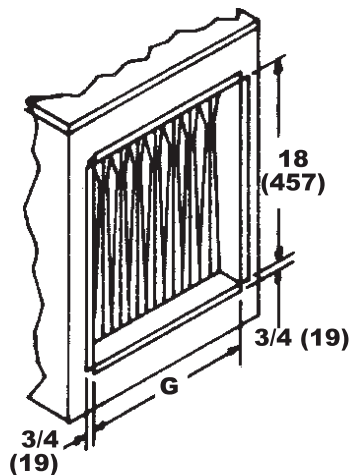

Figure 5. Duct Connection Dimensions

Requirements and Suggestions for Connecting and Installing Ducts

- **Type of ductwork:** The type of duct installation to be used depends in part on the construction type of the roof—whether wood or steel bar joist, steel truss, or pre-cast concrete—and the ceiling—whether hung, flush, etc.
- **Ductwork material:** Rectangular duct should be constructed of galvanized iron—not lighter than No. 26 US gauge—or aluminum—No. 24 B&S gauge.
- **Ductwork structure:** All duct sections 24 inches (610 mm) or wider and over 48 inches (1,219 mm) in length should be cross-broken on top and bottom and should have standing seams or angle-iron braces. Joints should be S and drive strip or locked.
- **Through masonry walls:** No warm air duct should come in contact with masonry walls. Insulate around all air duct through masonry walls with 1-inch (not less than 1/2-inch) of insulation.
- **Through unheated space:** Insulate all exposed warm air ducts passing through an unheated space with 1-inch (not less than 1/2-inch) of insulation.
- **Duct supports:** Suspend all ducts securely from adjacent buildings members. Do not support ducts from unit duct connections.
- **Duct sizing:** Proper sizing of the supply air ductwork is necessary to ensure a satisfactory heating installation. The recognized authority for duct size is the Air Conditioning Contractor's Association, 2800 Shirlington Road, Suite 300, Arlington, VA 22206 (www.acca.org). A manual covering duct sizing in detail may be purchased directly from them.

⚠ CAUTION ⚠

To prevent possible motor overloading, ensure that the external duct system static pressure is within the limits shown on the rating plate and that the motor pulley and belt are properly adjusted.

INSTALLATION—CONTINUED

Duct Connections—Continued

- **Horizontal discharge duct length:** To reduce losses at the furnace outlet, a minimum horizontal duct run of 24 inches (610 mm) is recommended before turns or branches are made in the duct system.

⚠ CAUTION ⚠

The joint where the supply air duct attaches to the furnace must be sealed securely to prevent air leakage into draft hood or burner rack area. Leakage can cause poor combustion and pilot problems, can shorten heat exchanger life, and can cause poor performance.

- **Supply air duct/furnace horizontal connection:** The seal between the furnace and the duct must be mechanical using U-type flanges on the top and bottom of the connecting duct to ensure tight joints and an airtight fit. Refer to **Figure 6** and perform the following steps:
 - a. Ensure that flanges on the furnace (heat exchanger) turn out as shown.
 - b. Shape duct connection as shown: U-type on top and bottom and L-type on sides.
 - c. Slide U-channels over furnace top and bottom flanges making connection.
 - d. Form U-channels to seal sides (see DETAIL A) and drill and lock with sheet metal screws.
- **Access panels:** Install removable access panels (see **Figure 6**) on both the upstream and downstream sides of the furnace. The access panels must be accessible when the furnace is in service and should be a minimum of 6 × 10 inches (152 × 254 mm) in size so smoke or reflected light may be observed inside the casing to indicate the presence of leaks in the heat exchanger. Ensure that the access panels are installed in such a manner so as to prevent leakage.
- **Return air duct/furnace connection:** All return air ducts should be attached and sealed to the return air flanges to provide airtight connections.
- **Return air duct/grill size:** Ensure that return air ducting or grills have a free area equal to the size of the return duct connection.

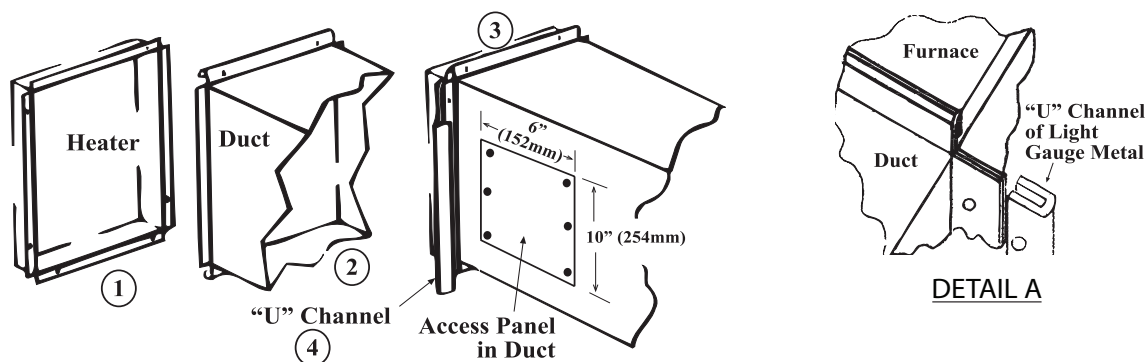

Figure 6. Connecting Ductwork to Furnace

Discharge Air Temperature Sensor Installation

- All makeup air options (options AG3, AG8, AG9, AG15, AG39, and AG40) require field-installation of the discharge air temperature sensor in the discharge ductwork.
- On units with option AG3, the factory-installed unit-mounted ductstat has a capillary tube with a sensor bulb that must be moved out the way—before installing the ductwork—and then field-installed in the discharge duct.
- On units with option AG8, AG9, or AG39, the discharge sensor includes a sensor and mixing tube.
- On units with option AG15, the discharge sensor includes a box and sensor holder.
- On units with option AG40, the discharge sensor is field-supplied.
- Install the sensor in the ductwork as follows:

1. Determine distance of sensor from unit:
 - a. For sensor with capillary tubing (option AG3), select ductwork location so that minimum length of capillary tubing will be inside ductwork.
 - b. Ensure that there is sufficient distance from outlet to have good mixture of discharge air temperature.

NOTES:

- According to the latest edition of AMCA Standard 201, in straight ducts, the air is typically well mixed a minimum of five equivalent duct diameters from the discharge of the unit with equivalent duct diameter defined as equal to the square root of $4AB/3.14$ (A and B are duct cross-sectional dimensions).
- Locate the sensor a minimum of 96 inches (2,435 mm) from the outlet of the unit.
- If the length of the discharge duct is less than 8 feet (2.4 meters), a mixing vane is recommended for mixing the discharge air. Do not mount the sensor in the ductwork after a split in the supply as this will cause loss of control in the duct that does not house the sensor.

- c. Refer to following formula for calculating sensor placement. This example assumes cross-sectional dimensions for supply ductwork of 24 × 12 inches (610 × 305 mm):

$$5 \text{ equivalent duct diameters} \times \sqrt{\frac{4 \times 12 \times 24}{3.14}} = 96 \text{ inches}$$

$$5 \text{ equivalent duct diameters} \times \sqrt{\frac{4 \times 305 \times 610}{3.14}} = 2435 \text{ millimeters}$$

2. Determine orientation of sensor:
 - a. In horizontal ductwork, position sensor in top-middle of duct with sensor probe extending vertically down into center of air stream.
 - b. In vertical ductwork, position sensor in middle of duct that corresponds with top-middle of discharge outlet.
3. Secure sensor in ductwork:
 - a. For units with option AG3:
 - (1) Ductstat and sensor are connected by permanently-attached capillary tube. Before connecting ductwork, remove capillary tube sensor bulb with bracket from its shipping position on furnace (see [Figure 7](#), DETAIL A).

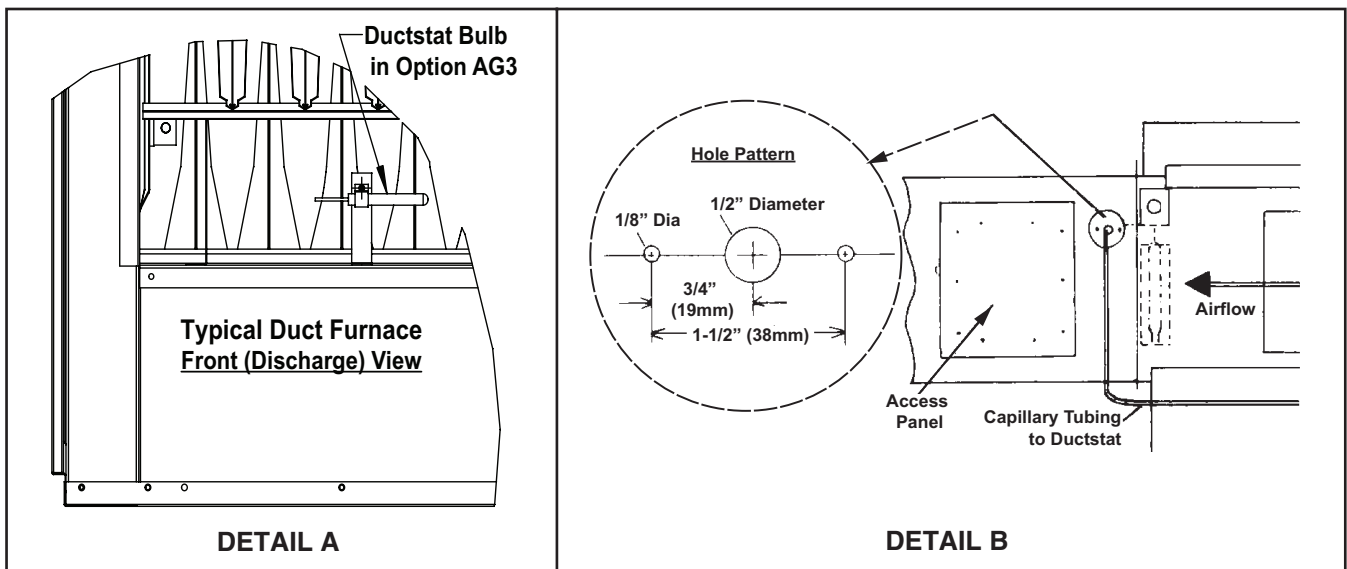

Figure 7. Capillary Sensor Bulb Installation (Option AG3)

INSTALLATION—CONTINUED

Duct Connections—Continued

Discharge Air Temperature Sensor Installation—Continued

NOTE: Because the sensor is larger than the tubing, a gasket and gasket retainer plate are needed to plug the hole and to protect the capillary tubing where it passes through the ductwork. These parts are shipped loose with the furnace (refer to [Table 5](#)). Two field-supplied sheet metal screws are needed to secure the plate.

- (2) Drill holes in ductwork in accordance with hole pattern shown in [Figure 7](#), DETAIL B.
 - (3) Remove ductwork access panel (see [Figure 7](#), DETAIL A).
 - (4) Remove sensor bulb from bracket and push sensor through 1/2-inch hole. While reaching through access hole, use retaining clip to reinstall sensor to bracket.
 - (5) Slide gasket (cut slit) and hole retainer plate over capillary tubing. With gasket next to ductwork, install hole retaining plate and secure using field-supplied sheet metal screws.
 - (6) Close ductwork access panel.
- b. For units with option AG8, AG9, AG15, or AG39:
- (1) Position of sensor in duct is also important—mixing tube shown in [Figure 8](#), DETAIL A is 12 inches (305 mm) long and holder shown in [Figure 8](#), DETAIL B extends 9-3/16 inches (233 mm) into ductwork.
 - (2) Turn holder so that element is shielded from direct airflow and will sense air temperature as it flows through holes in holder.
 - (3) At selected ductwork location, mark diamond-shaped hole—approximately 1 × 1 inch (25 × 25 mm—required for sensor holder or round hole required for mixing tube and cut hole no larger than necessary.
 - (4) For units with option AG8 or AG9, slide mixing tube (see [Figure 8](#), DETAIL A) into ductwork and attach sensor.
 - (5) For units with AG15, push element into clip in holder (see [Figure 8](#), DETAIL B), slide holder into ductwork, and position holder so that it shields sensor from direct airflow. Secure box portion of holder to ductwork using four field-supplied #6 sheet metal screws.

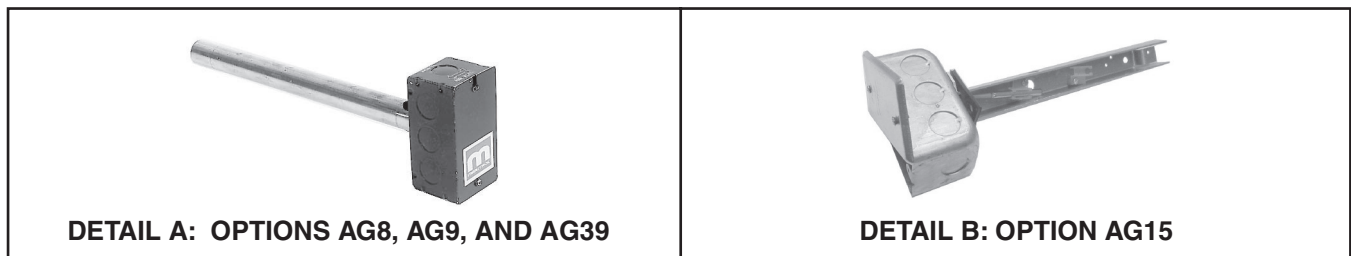

Figure 8. Discharge Air Temperature Sensor and Holder

- c. For units with option AG40, install field-supplied sensor in accordance with instructions provided with sensor.
4. Connect sensor wires:
- a. For units with option AG15:
 - (1) Determine where sensor wire should enter box and remove knockout.
 - (2) Secure field-supplied cable connector to box, connect sensor wire, and install box cover.
 - b. For all options, ensure that all sensor wires are connected in accordance with wiring diagram provided with unit.

Duct Furnace Airflow

The duct furnace must be installed on the positive pressure side of the field-supplied blower. Air throughput must be within the CFM range stated on the heater rating plate. The air distribution must be even over the entire heat exchanger. To determine temperature rise, the inlet and outlet air temperatures should be measured at points not affected by heat radiating from the heat exchanger. Refer to the [Table 7](#) section for the approved temperature rise range with the required CFM and the internal pressure drop for each size of unit. Refer to the [Field-Supplied Blower Connections](#) section for suggested blower connections that include turning vanes used in elbows or turns in the air inlet to ensure proper air distribution. If it is determined that the blower CFM is greater than that which is allowed or desirable, refer to the [Bypass Duct Construction](#) section for instructions on determining the correct size of bypass duct required.

Table 7. Temperature Rise, CFM, and Pressure Drop

Temperature Rise	Unit Size																			
	100		125		150		175		200		225		250		300		350		400	
	CFM	PD*	CFM	PD*	CFM	PD*	CFM	PD*	CFM	PD*	CFM	PD*	CFM	PD*	CFM	PD*	CFM	PD*	CFM	PD*
Model SC Series 6 (80% Thermal Efficient)																				
30°F	2465	1.38	3085	1.39	3700	1.00	4320	1.49	4935	1.14	5555	1.48	6170	1.17	7400	1.61	8640	1.87	9875	1.87
40°F	1850	0.78	2310	0.78	2775	0.56	3240	0.81	3700	0.64	4165	0.83	4630	0.66	5555	0.91	6480	1.05	7400	1.05
50°F	1480	0.50	1850	0.50	2220	0.36	2590	0.52	2960	0.41	3330	0.53	3700	0.42	4440	0.58	5185	0.67	5925	0.67
55°F	1345	0.34	1680	0.41	2020	0.30	2355	0.43	2690	0.34	3030	0.44	3365	0.35	4040	0.48	4710	0.55	5385	0.55
60°F	1235	0.29	1540	0.34	1850	0.26	2160	0.36	2465	0.28	2775	0.37	3085	0.30	3700	0.40	4320	0.46	4935	0.46
70°F	1055	0.21	1320	0.25	1585	0.19	1850	0.26	2115	0.21	2380	0.27	2645	0.22	3175	0.30	3700	0.34	4230	0.34
80°F	925	0.16	1155	0.19	1385	0.14	1620	0.20	1850	0.17	2080	0.21	2315	0.20	2775	0.23	3240	0.26	3700	0.26
85°F	870	0.14	1085	0.18	1305	0.13	1525	0.18	1740	0.15	1960	0.19	2175	0.20	2610	0.22	3050	0.23	3485	0.23
90°F	820	0.12	1025	0.16	1235	0.12	1440	0.16	1645	0.13	1850	0.17	2055	0.18	2465	0.20	2880	0.21	3290	0.21

*PD = internal pressure drop (IN WC).

Field-Supplied Blower Connections

⚠ WARNING ⚠

The furnace must be installed on the positive pressure side of the air-circulating blower.

Blower connection requirements are as follows:

- Blowers should be bottom horizontal discharge when coupled to the duct furnace.
- When a top horizontal discharge blower is connected to the ductwork, ensure that the duct is of sufficient length to permit the even flow of air at the end of the duct. Alternatively, baffles may be inserted between the blower and the heater to assure an even flow of air across the heat exchanger.
- If a higher CFM is required through the furnace within the limits listed in [Table 8](#), install the high CFM conversion kit (PN [263309](#)) that is shipped with the unit.

Table 8. High Air Throughput with High CFM Kit (PN [263309](#))

Unit Size	Maximum	Minimum
	CFM	
100	3700	980
125	4630	1230
150	5555	1480
175	6480	1725
200	7405	1975
225	8330	2220
250	9255	2465
300	11,110	2960
350	12,900	3455
400	14,815	3950

INSTALLATION—CONTINUED

Duct Connections—Continued

Field-Supplied Blower Connections—Continued

- Proper arrangements of the blower and the duct furnace with respect to the angle of approach of the duct connection and the arrangement of the discharge opening of the blower are shown in [Figure 9](#).

⚠ CAUTION ⚠

Abrupt angle approaches shown in [Figure 9](#) can be detrimental to unit life. Ensure that ample air is directed at the base of the tube section by using turning vanes as shown.

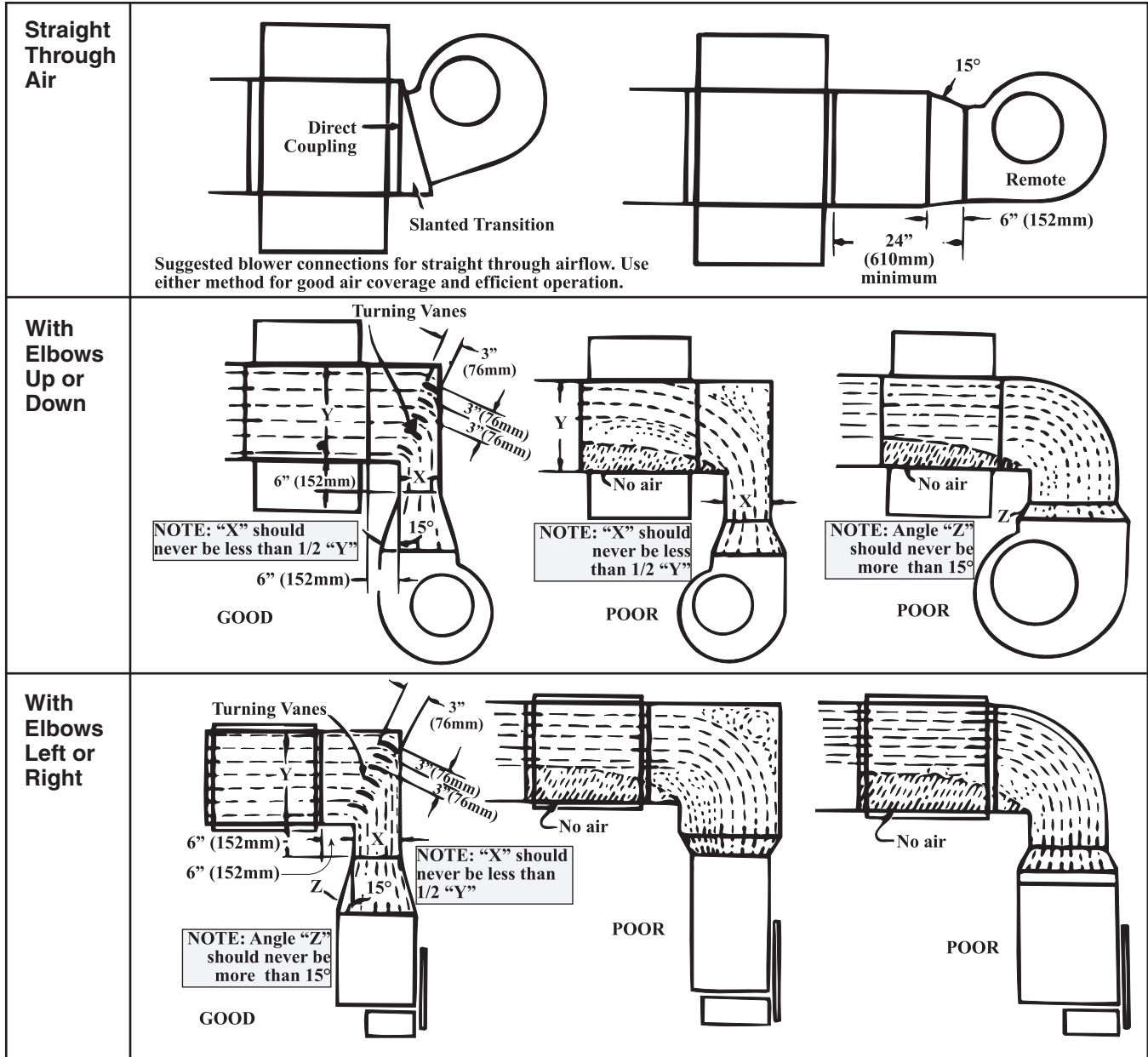

Figure 9. Suggested Blower Connections

Bypass Duct Construction

When the CFM of air throughput is greater than that which is desirable or permissible for the unit, a bypass duct (see [Figure 10](#)) may be constructed. Determine the correct size of the bypass duct as follows:

1. Refer to [Table 7](#) to determine pressure drop and allowable CFM for furnace being installed (e.g., standard size SC250 @ 50°F temperature rise: pressure drop = 0.36 and allowable CFM = 2,220).
2. Subtract allowable CFM from **actual** CFM to determine how much air must be diverted through bypass duct (e.g., **actual** CFM = 3,000: $3,000 - 2,220 = 780$ (bypass CFM)).
3. Refer to [Table 9](#) to determine duct size based on closest bypass CFM value in column topped by closest pressure drop value (e.g., pressure drop = 0.36 (go to 0.35 column) and bypass CFM = 780 (830 is closest value in that column), therefore, bypass duct A dimension (see [Figure 10](#)) = 3 inches (76 mm).

NOTES:

- The depth of the bypass duct is 18 inches on both inlet and outlet ends. The bypass duct must be located on the side opposite the controls and 2 inches from the heat exchanger side panel.
- Not all capacities are covered in [Table 9](#). If your installation is not covered, the correct size may be determined by consulting your Factory Representative.

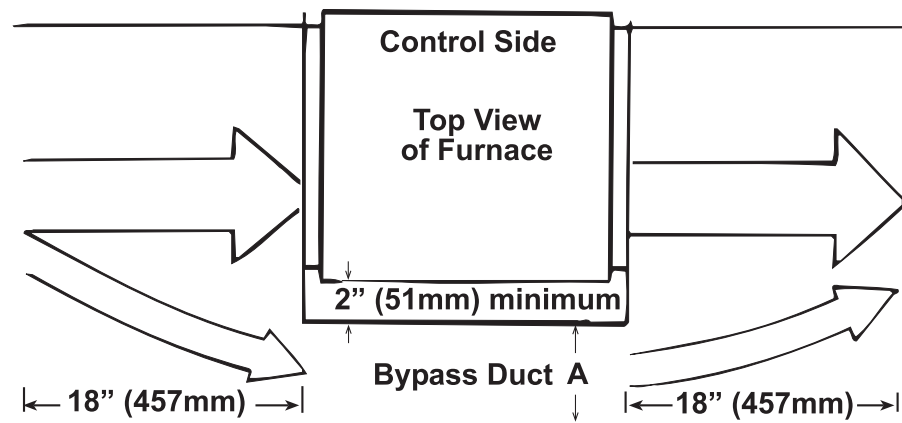

Figure 10. Bypass Duct

Table 9. Bypass Duct Sizing

Dimension A (Inches (mm))*	Pressure Drop (IN WC)								
	0.10	0.15	0.20	0.25	0.30	0.35	0.40	0.45	0.50
	Bypass CFM								
3 (76)	490	530	610	700	780	830	900	960	1010
4 (102)	630	750	870	980	1090	1160	1250	1310	1400
5 (127)	850	1010	1190	1300	1410	1520	1640	1730	1810
6 (152)	1050	1290	1480	1650	1800	1940	2090	2200	2320
7 (178)	1250	1510	1760	1960	2180	2320	2500	2650	2800
8 (203)	1490	1810	2100	2350	2560	2760	2940	3110	3290
9 (229)	1700	2100	2400	2700	2970	3200	3400	3600	3800
10 (254)	1920	2350	2760	3090	3650	4020	4300	4550	4800

*See [Figure 10](#).

INSTALLATION—CONTINUED

Venting/Combustion Air Connections

⚠ WARNING ⚠

Do not use an existing venting system. This heater requires installation of the combustion air/vent system ordered with the unit (either option CC2 or CC6). Vent installation to be any listed vent system manufacturer. Do not intermix different vent system parts from different manufacturers in the same venting system.

- All separated-combustion, power-vented units **MUST BE** equipped with both combustion air and exhaust piping to the outdoors. The unique concentric adapter box designed for use with this heater allows for both combustion air and exhaust piping with only one horizontal or vertical penetration hole in the building.
- These instructions apply to installation and use of the concentric adapter and vent/combustion air kit (option CC2 or CC6) designed for use with all Reznor separated-combustion products. The systems illustrated in this manual are the only venting/combustion air systems approved for these separated-combustion units. Do not use this concentric adapter box with any other products.
- Installation should be done by a qualified agency in accordance with these instructions. The service agency installing this separated-combustion system is responsible for the installation.

Specific Venting Requirements: Piping

All pipe is field-supplied. Requirements for both the vent pipe and the combustion air inlet pipe are as follows:

- **Vent pipe:** Vent pipe approved for a Category III appliance OR single-wall, 26-gauge or heavier galvanized (or a material of equivalent durability and corrosion resistance) vent pipe is required between the heater and the concentric adapter box. Double-wall (Type B) vent pipe is required for the vent terminal section. The length of vent pipe that extends through the box and runs concentric through the combustion air pipe must be one piece with no joints.
- **Combustion air pipe:** Sealed, single-wall galvanized pipe is recommended for combustion air.
- **Pipe length and diameter:** Vent pipe diameters and maximum indoor vent lengths apply to both horizontal and vertical vents. Pipe diameter and length requirements listed for the indoor sections of pipe—between the heater and the concentric adapter box—are listed in [Table 10](#).

NOTE: Add all straight sections and equivalent lengths for elbows. The total length of the straight sections and elbows must not exceed the maximum length.

- **Outdoor concentric pipes length and diameter:** The lengths of the outside (terminal) concentric pipes depend on the installation. The diameters are 8 inches (203 mm) for the inlet air pipe and 5 inches (127 mm) for the vent pipe.

Diameter/Length	Unit Size			
	100	125–175	200–300	350, 400
Diameters (Inches (mm))				
Vent pipe	6 (152)			
	—		7 (178)	
Inlet air pipe	6 (152)			
	—		7 (178)	
Lengths (Feet (Meters))				
Minimum	5 (1.5)			
Maximum, 6-inch pipe	40 (12)	50 (15)		30 (9)
Maximum, 7-inch pipe	—		70 (21)	
Equivalent straight length for 45-degree elbow	4 (1.2)			
Equivalent straight length for 90-degree elbow	8 (2.4)			

Specific Venting Requirements: Venter Outlet and Combustion Air Inlet Connections

⚠ DANGER ⚠

All separated-combustion units **MUST BE** equipped with both combustion air and exhaust piping to the outdoors.

Model SC heaters have both an inlet air and a venter outlet connection. Both are 6 inches (152 mm) in diameter for all unit sizes.

NOTE: If using 7-inch pipe on unit sizes 200–400, use a tapered 6- to 7-inch enlarger to attach the vent pipe and a 7- to 6-inch reducer to attach the combustion air pipe.

Specific Venting Requirements: Joints and Sealing

Seal pipe joints as follows:

- **To seal joints in Category III vent pipe:** Follow the pipe manufacturer's instructions for joining and sealing Category III vent pipe sections.
- **To seal joints in single-wall vent or combustion air pipe:** Secure slip-fit pipe connections using sheet metal screws or rivets. Seal all joints with aluminum tape or silicone sealant.
- **To seal the joint in the terminal section of double-wall vent pipe (allowed ONLY ABOVE the concentric pipes on a VERTICAL vent):** Follow the pipe manufacturer's instructions for joining and sealing double-wall vent pipe sections.
- **To seal the joint between the terminal section of double-wall vent pipe and the vent cap:** Follow the illustrated step-by-step instructions in [Figure 11](#).
- **To seal the joint between the terminal section of double-wall vent pipe and a single-wall or Category III vent pipe:** follow the illustrated step-by-step instructions in [Figure 12](#). Make this connection no more than 6 inches (152 mm) from the concentric adapter box.

NOTE: Pipes and vent caps may not look exactly as shown in the illustrations. Instructions apply to both horizontal and vertical vent kits.

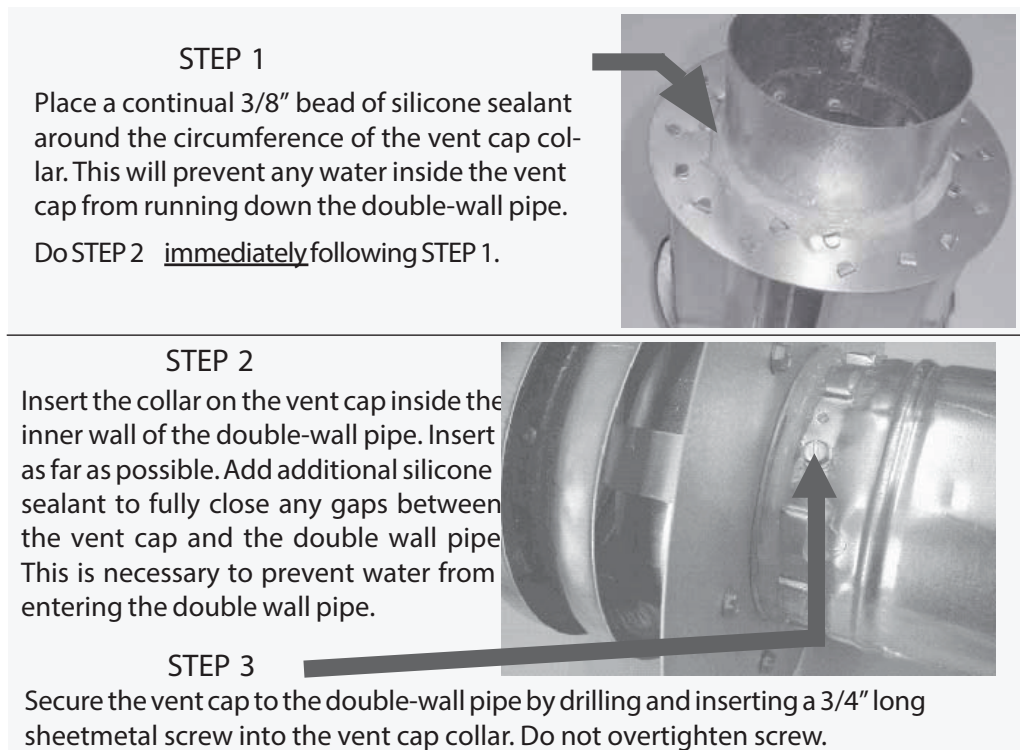

Figure 11. Joining Double-Wall (Type B) Pipe to Vent Terminal Cap (Horizontal or Vertical)

INSTALLATION—CONTINUED

Venting/Combustion Air Connections—Continued

Specific Venting Requirements: Joints and Sealing—Continued

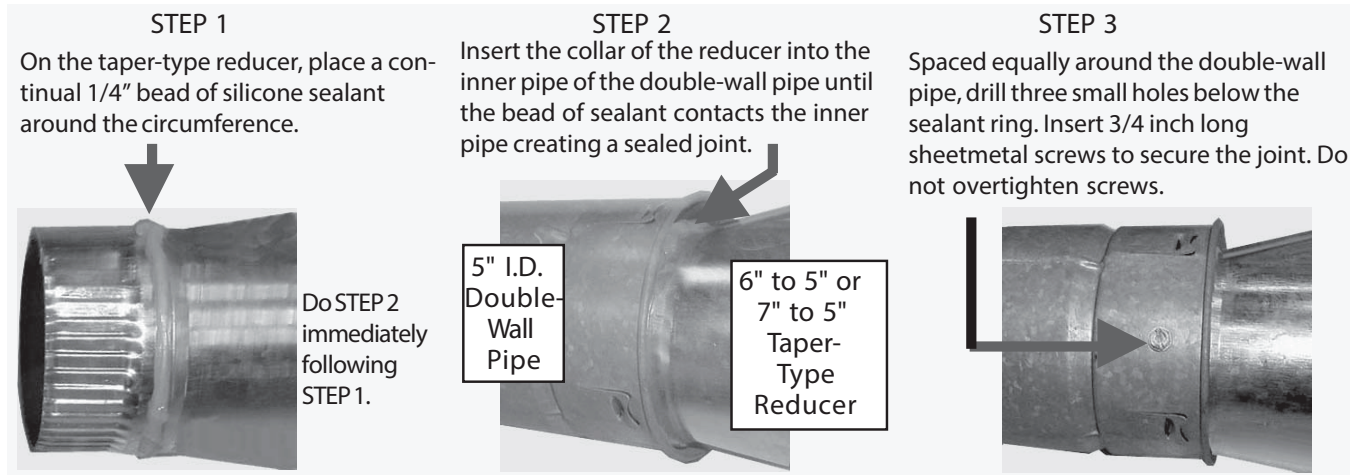

Figure 12. Joining Double-Wall (Type B) Pipe to Single-Wall or Category III Vent Pipe Using Tapered Reducer

Specific Venting Requirements: Support

Support horizontal runs every six feet (1.8 meters). Support vertical runs of Type B double-wall or Category III vent pipe in accordance with the requirements of the pipe manufacturer. Support single-wall vertical pipe in accordance with accepted industry practices. Do not rely on the heater or the adapter box for support of either horizontal or vertical pipes. Use noncombustible supports on vent pipe.

NOTE: The double-wall vent terminal pipe does not attach to the concentric adapter box and must be supported during installation.

Specific Venting Requirements: Clearance

Do not enclose the vent pipe or place pipe closer than 6 inches (152 mm) to combustible material.

Specific Venting Requirements: Concentric Adapter Box

The concentric adapter box (PN [205885](#)) is included in the vent/combustion air kit. Installation instructions depend on whether the vent system is horizontal (option CC6) or vertical (option CC2). All separated-combustion installations require a concentric adapter box as shown in [Figure 13](#).

View of Heater Connection Side

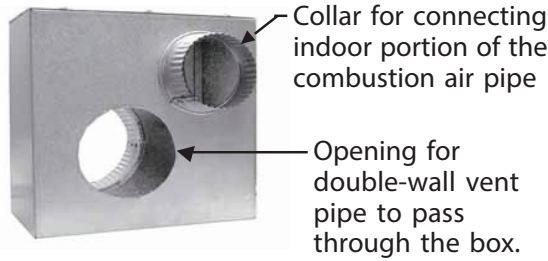

View of Vent Terminal Connection Side

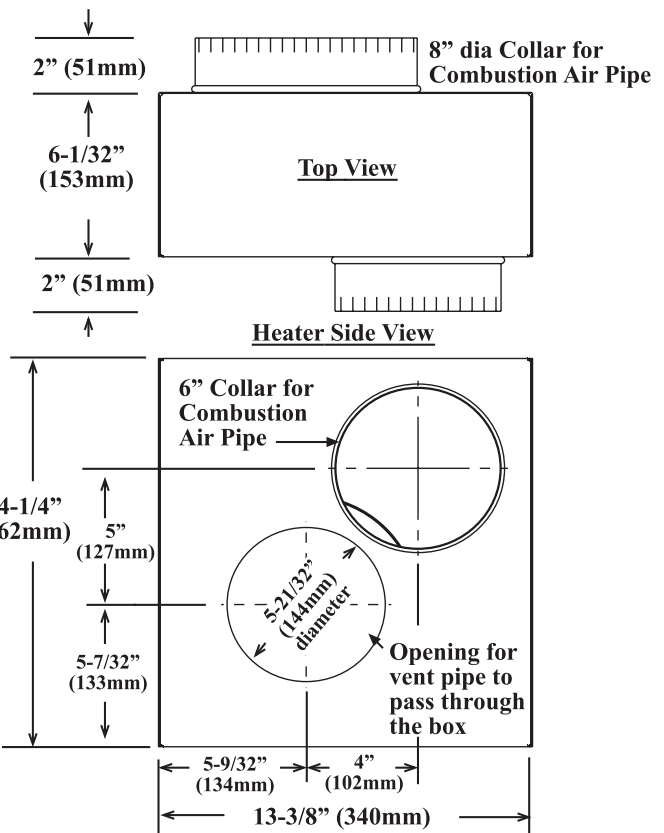
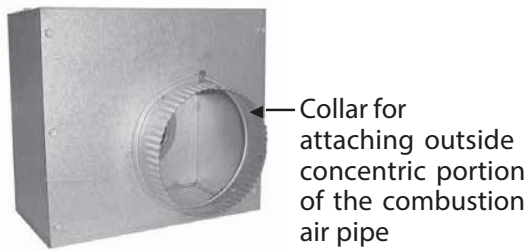

Concentric Adapter Box Airflow

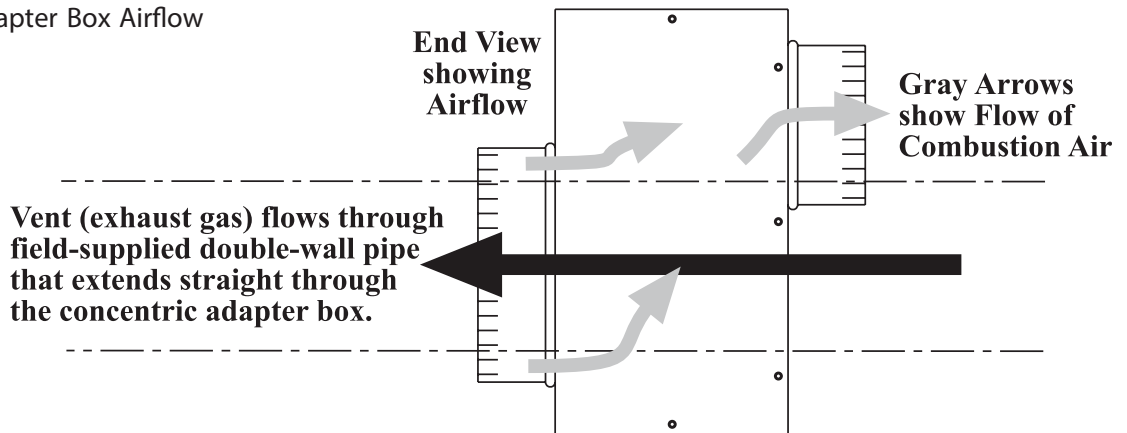

Figure 13. Concentric Adapter Box

Specific Venting Requirements: Concentric Adapter Box Pipe Connections

NOTE: Do NOT make actual connections until after reading the instructions and length requirements for installing the vent/combustion air kit. The connection requirements are the same for both vertical and horizontal systems, but the length of the double-wall pipe will vary.

When pipe diameters differ, depending on direction of airflow, join the pipes with either a tapered reducer or enlarger as shown in [Figure 14](#).

INSTALLATION—CONTINUED

Venting/Combustion Air Connections—Continued

Specific Venting Requirements: Concentric Adapter Box Pipe Connections—Continued

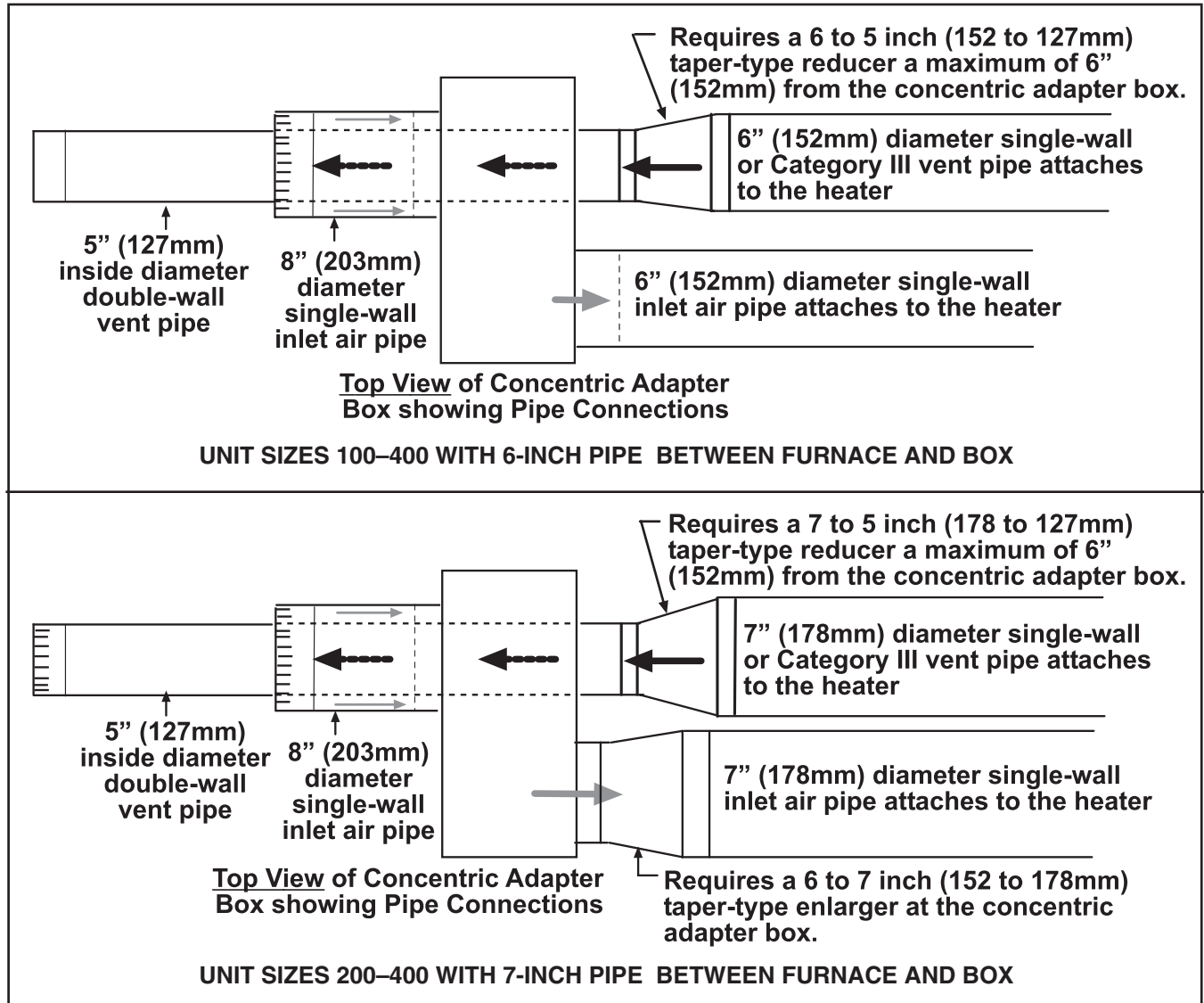

Figure 14. Concentric Adapter Box Connections

Vent Terminal Options

Vent terminal options CC2 (vertical vent configuration) and CC6 (horizontal vent configuration) are shown in [Figure 15](#).

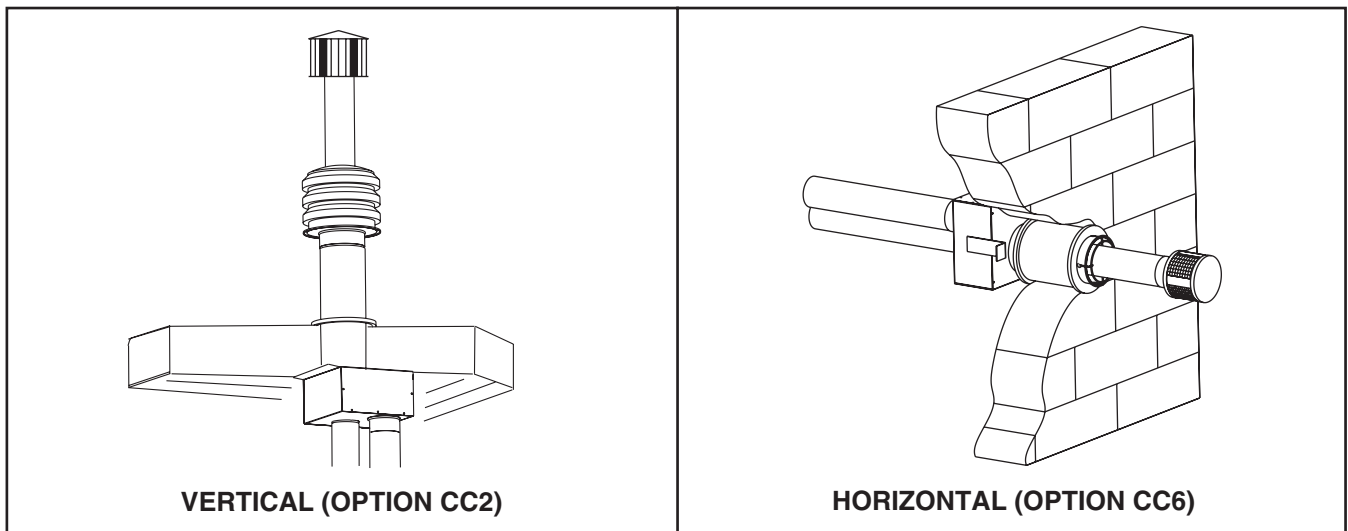

Figure 15. Horizontal and Vertical Venting Options

Vertical Vent Terminal (Option CC2) Installation

- Field-supplied components required for installation of the vertical vent kit are as follows:
 - a. Vent and combustion air piping in accordance with [Table 10](#)
 - b. Tapered vent pipe diameter reducers and/or increasers, as required
 - c. Thimble (not required if wall is of non-combustible construction)
 - d. Flashing
 - e. Sheet metal screws, tape, and sealant, as required
- Factory-supplied components for installation of the vertical vent kit are listed in [Table 11](#).

Table 11. Vertical Vent Terminal/Combustion Air Package (Option CC2) Components		
PN	Description	Quantity
205896	Kit package	1
205885	Concentric adapter box (see Figure 13)	1
110052	Exhaust vent terminal assembly (see Figure 16)	1
53330	Combustion air inlet assembly (see Figure 16)	1
207232	Concentric adapter box bracket	2
53335	High-temperature silicone sealant, tube	1

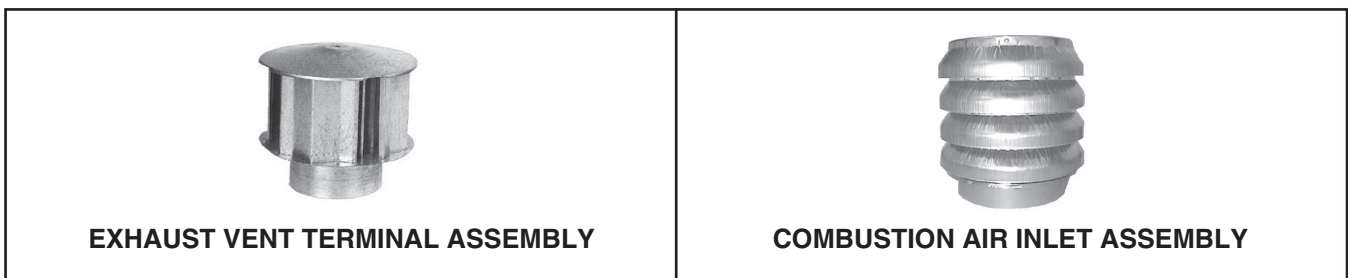

Figure 16. Option CC2 Components

INSTALLATION—CONTINUED

Venting/Combustion Air Connections—Continued

Vertical Vent Terminal (Option CC2) Installation—Continued

⚠ DANGER ⚠

To prevent combustion products from entering the occupied space, all vent terminals must be positioned or located away from fresh air intakes, doors, and windows. Failure to comply could result in severe personal injury or death and/or property damage.

1. Determine vent terminal location on roof:
 - a. If more than one vertical vent terminal is being installed, minimum spacing between vent center lines is determined by minimum outdoor design temperature (coldest outdoor condition at installation site). Refer to [Table 12](#) to ensure that location complies with minimum outdoor design temperature requirements.

Minimum Outdoor Design Temperature	Minimum Spacing Between Center Lines of Vertical Vent Pipes (Inches (mm))
≥31°F (≥0°C)	36 (914)
-10 to 30°F (-23 to -1°C)	60 (1524)
< -10°F (< -23°C)	84 (2134)

- b. Select location away from fresh air intakes, allowing space for concentric adapter box inside. Vent terminal must be located away from adjacent buildings as shown in [Figure 17](#).
2. Install vent pipe and combustion air pipe runs:
 - a. Connect piping to heater in accordance with specifications listed in [Specific Venting Requirements: Piping and Specific Venting Requirements: Venter Outlet and Combustion Air Inlet Connections](#) sections.
 - b. Seal all joints in accordance with specifications listed in [Specific Venting Requirements: Joints and Sealing](#) section. Due to high temperature considerations, do not enclose exhaust pipe or place pipe closer than 6 inches (152 mm) to combustible material.
 - c. Extend piping runs close to roof at location selected in step 1 and support piping in accordance with specifications listed in [Specific Venting Requirements: Support](#) section.

NOTE: The vent pipe will extend through the roof after the concentric adapter box is installed. The indoor combustion air pipe will end at the box.

3. Cut hole through roof for combustion air pipe.
 - a. Ensure that location and orientation of concentric adapter box are correct and mark and cut hole.
 - b. Ensure that hole accommodates 8-inch (203-mm) combustion air pipe. Thimble may be required depending on building construction and/or local codes. Larger diameter combustion air pipe serves as clearance for vent pipe on non-combustible construction.

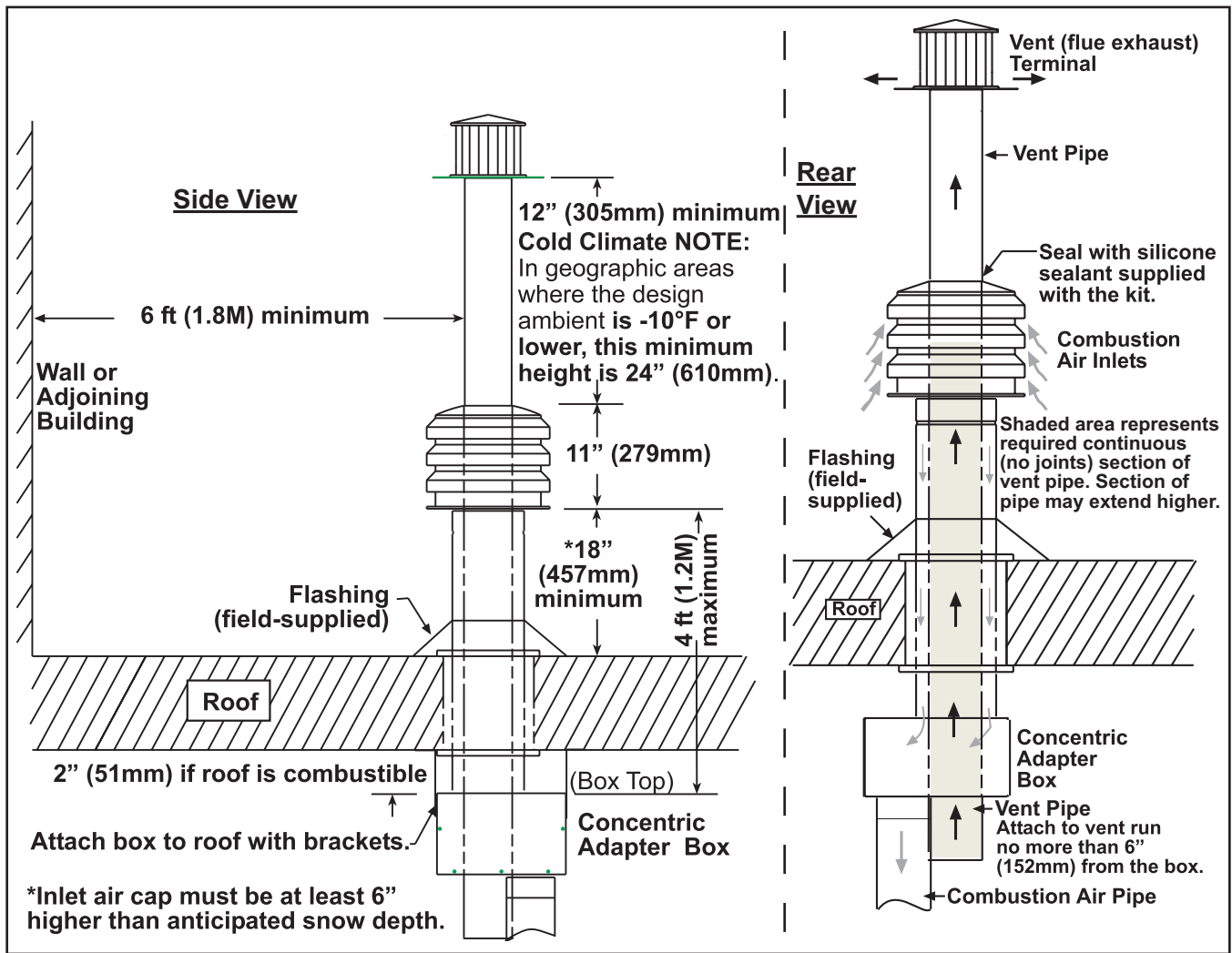

Figure 17. Option CC2 Installation

- Secure longer angles on concentric adapter box brackets (see [Figure 18](#)) to concentric adapter box.

NOTE: The longer angle of the concentric adapter box bracket has five 7/32-inch holes that allow the position of the bracket on the box to be adjusted. The shorter angle has three 7/32-inch holes that allow adjustment to construction.

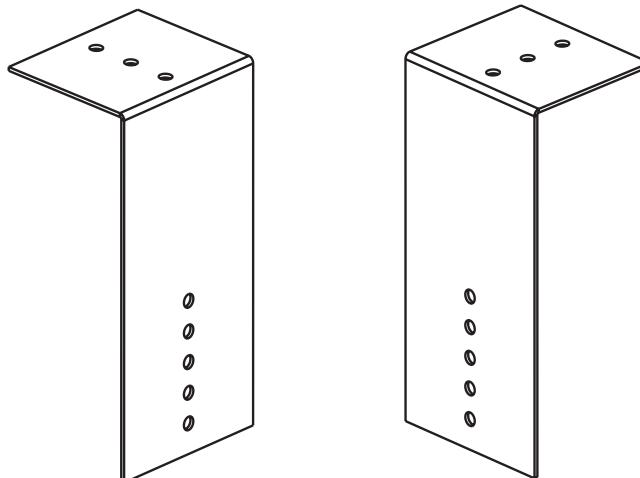

Figure 18. Concentric Adapter Box Brackets

INSTALLATION—CONTINUED

Venting/Combustion Air Connections—Continued

Vertical Vent Terminal (Option CC2) Installation—Continued

5. Connect outside section of combustion air pipe to concentric adapter box (see **Figure 19**):
 - a. Determine length of combustion air pipe so that dimension X in **Figure 19** is equal to bracket length plus roof thickness and plus anticipated snow depth. Ensure that length of combustion air pipe does not exceed 48 inches (1,219 mm) or does not extend **less than** 18 inches (457 mm) above roof.
 - b. Secure inlet air pipe to collar of concentric adapter box using sheet metal screws. Seal joint and seam using tape or sealant.

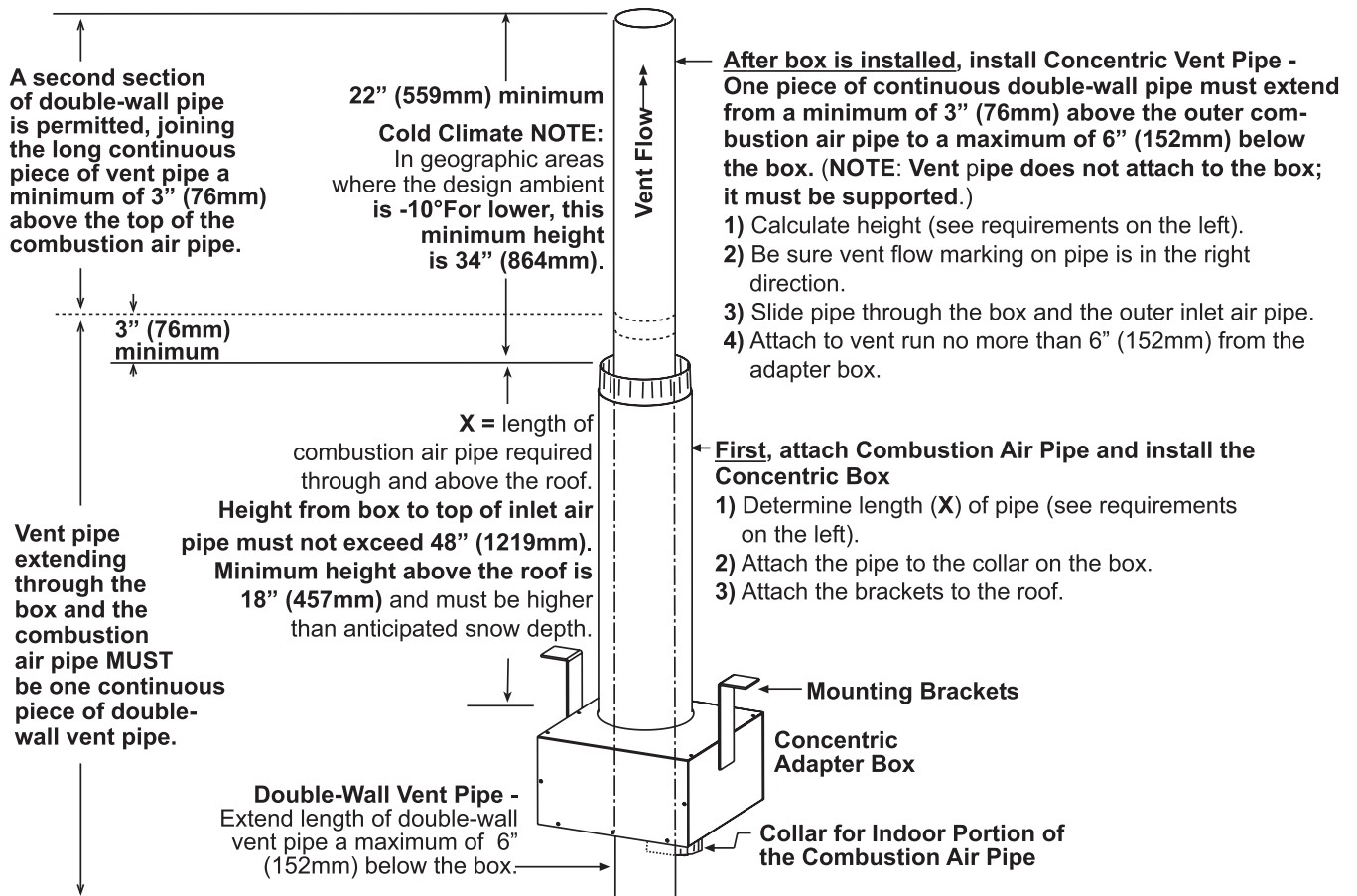

Figure 19. Combustion Air Pipe Installation

6. Secure concentric adapter box to underside of roof (see **Figure 19**):

⚠ CAUTION ⚠

- If the roof is combustible, ensure that brackets are positioned to allow a 2-inch (51 mm) clearance between the concentric adapter box and the roof.
- If any holes are made in the concentric adapter box in error, ensure that they are sealed.

- a. Insert combustion air pipe through roof as shown in **Figure 20**.
- b. Position concentric adapter box to match pipe runs and secure short angles of concentric adapter brackets (see **Figure 18**) to underside of roof using field-supplied hardware.
- c. Install field-supplied flashing around combustion air pipe on roof outside.

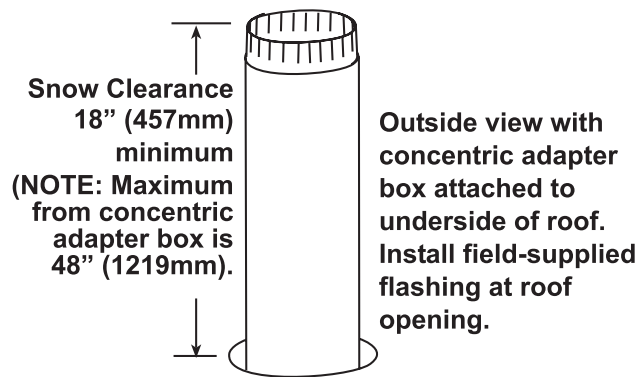

Figure 20. Combustion Air Pipe Through Roof

7. Install double-wall terminal vent pipe:

NOTE: The length of the vent pipe is determined by the installation within maximum and minimum requirements. The vent pipe extending through the box and the inlet air pipe must be one piece of double-wall vent pipe without joints.

- a. Refer to [Figure 19](#) to determine lengths of each pipe segment and to calculate total length required. Determine minimum length by adding requirements:
 - (1) Starting at bottom, vent pipe can extend maximum of 6 inches (152 mm) below box
 - (2) Plus 6 inches (152 mm) through box
 - (3) Plus length of brackets above box
 - (4) Plus width of roof
 - (5) Plus height of outside combustion air pipe above roof
 - (6) Plus minimum of 3 inches (76 mm) beyond top of inlet air pipe
 - (7) Total is minimum length of vent pipe section—if actual piece of vent pipe is longer, extend it farther above combustion air pipe—do not extend it more than 6 inches (152 mm) below box
- b. Ensure that double-wall terminal vent pipe is in proper direction and slide end of pipe into box and out through combustion air pipe. Position vent pipe to lengths determined above.

NOTE: The double-wall vent pipe does not attach to the box. The installer must provide support.

- c. Connect double-wall vent pipe to single-wall or Category III vent pipe run using tapered reducer in accordance with [Figure 12](#).
 - d. Seal completely around circumference of pipe and opening of box using silicone sealant.
8. Install combustion air inlet (see [Figure 21](#)):
- a. On outside, slide combustion air inlet over vent pipe and fasten collar to combustion air pipe using sheet metal screws.
 - b. Seal opening at top between vent pipe and combustion air inlet to prevent water leakage using silicone sealant.
9. Install exhaust vent terminal (see [Figure 21](#)) in accordance with [Figure 11](#).
10. Install indoor combustion air pipe:
- a. Secure single-wall combustion air pipe run to collar on concentric adapter box using sheet metal screws. If using 7-inch piping (unit sizes 200–400), install tapered enlarger as shown in [Figure 14](#).
 - b. Seal pipe joints with tape or sealant.
11. Verify compliance with [Figure 17](#) and with all specific venting requirements listed above.

INSTALLATION—CONTINUED

Venting/Combustion Air Connections—Continued

Vertical Vent Terminal (Option CC2) Installation—Continued

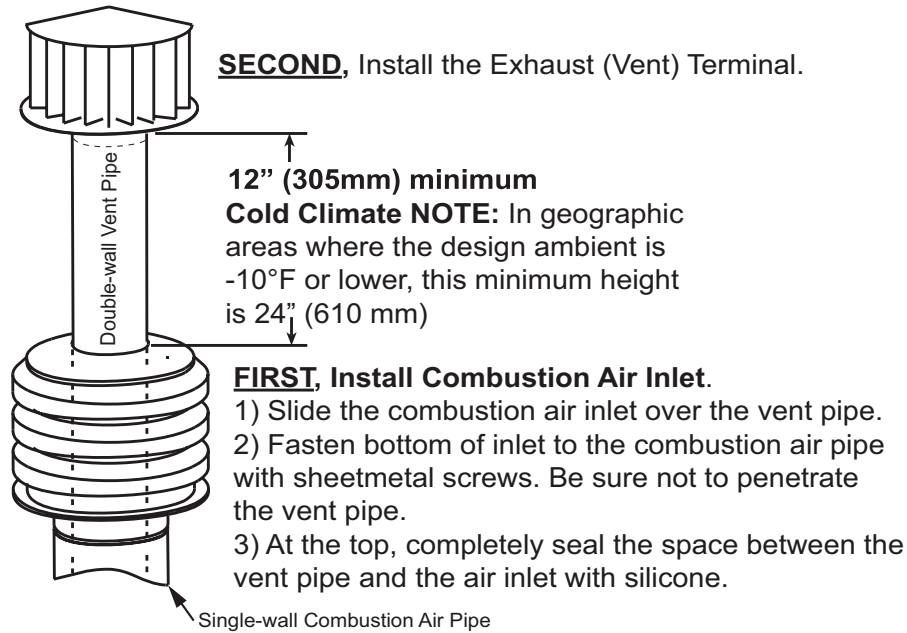

Figure 21. Combustion Air Inlet and Vent Terminal Installation

Horizontal Vent Terminal (Option CC6) Installation

- Field-supplied components required for installation of the horizontal vent kit are as follows:
 - a. Vent and combustion air piping in accordance with [Table 10](#)
 - b. Tapered vent pipe diameter reducers and/or increasers, as required
 - c. Thimble (not required if wall is of non-combustible construction)
 - d. Flashing
 - e. Sheet metal screws, tape, and sealant, as required
- Factory-supplied components for installation of the horizontal vent kit are listed in [Table 13](#).

PN	Description	Quantity
205883	Kit package	1
205885	Concentric adapter box (see Figure 13)	1
53316	Assembly, screened exhaust (see Figure 22)	1
205894	Inlet guard (see Figure 22)	1
37661	Screw, sheet metal, #10-16 × 1/2	4
207232	Concentric adapter box bracket	2
53335	High-temperature silicone sealant, tube	1

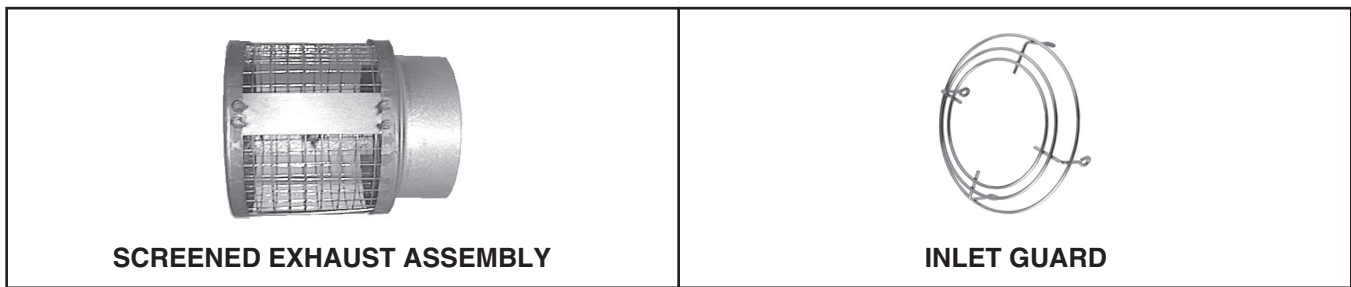

Figure 22. Option CC6 Components

⚠ DANGER ⚠

- To prevent combustion products from entering the occupied space, all vent terminals must be positioned or located away from fresh air intakes, doors, and windows. Failure to comply could result in severe personal injury or death and/or property damage.
- In climates with below freezing temperatures, condensate may form icicles on the vent terminal. Locate the terminal where falling icicles do not present a hazard.
- Consider local snow depth conditions. The vent must be at least 6 inches (152 mm) above the anticipated snow depth.

1. Determine vent terminal location on outside wall:
 - a. Refer to [Table 10](#) to ensure that location complies with vent length requirements.
 - b. For most applications, ensure that vent terminal is level with heater mounting height.
 - c. Allow downward pitch of 1/4-inch per foot (6 mm per 305 mm) for condensate drain.

NOTE: Local codes supersede all provisions in these instructions and in *National Fuel Gas Code Z223.1*.

- d. Ensure that distance of vent terminal from adjacent public walkways and buildings and window and building openings complies with local codes. Absent any local codes, distance must comply with *National Fuel Gas Code Z223.1*.

⚠ WARNING ⚠

Avoid positioning the vent terminal above a walkway as there may be a small amount of condensate that drips from the end of the vent/combustion air terminal. In cold climates, the condensate may form ice.

⚠ CAUTION ⚠

Products of combustion can cause discoloration of some building finishes and deterioration of masonry materials. A clear silicone sealant normally used to protect concrete driveways may be used to protect masonry materials from discoloration and deterioration. If discoloration is an esthetic problem relocate the vent or install a vertical vent.

- e. Refer to [Table 14](#) to ensure that location complies with minimum clearance requirements.

INSTALLATION—CONTINUED

Venting/Combustion Air Connections—Continued

Horizontal Vent Terminal (Option CC6) Installation—Continued

Component/Structure	Minimum Clearance, All Directions Unless Specified (Feet (Meters))
Forced air inlet within 10 feet (3.1 meters)*	3 (0.9) above
Combustion air inlet of another appliance	6 (1.8)
Mechanical air supply inlet to any building	Canada: 6 (1.8)
Any building opening (door, window, or gravity air inlet)	4 (1.2) horizontal and below
	1 (0.3) above
Gas meter,** electric meter, and relief equipment	US: 4 (1.2) horizontal
	Canada: 6 (1.8) horizontal
Gas regulator**	US: 3 (0.9) horizontal
	Canada: 6 (1.8) horizontal
Adjoining building or parapet	6 (1.8)
Adjacent public walkway	7 (2.1) above
Grade (ground level)	3 (0.9) above
*Does not apply to the inlet of a direct vent appliance.	
**Do not terminate the vent directly above a gas meter or service regulator.	

2. Install vent pipe and combustion air pipe runs:
 - a. Connect piping to heater in accordance with specifications listed in [Specific Venting Requirements: Piping](#) and [Specific Venting Requirements: Venter Outlet and Combustion Air Inlet Connections](#) sections.
 - b. Seal all joints in accordance with specifications listed in [Specific Venting Requirements: Joints and Sealing](#) section. Due to high temperature considerations, do not enclose exhaust pipe or place pipe closer than 6 inches (152 mm) to combustible material.
 - c. Extend piping runs close to wall location selected in step 1 and support piping in accordance with specifications listed in [Specific Venting Requirements: Support](#) section.
3. Cut hole through outside wall for combustion air pipe.
 - a. Ensure that outside wall construction thickness is between 1 inch (25 mm) minimum and 48 inches (1,219 mm) maximum.
 - b. Ensure that hole accommodates 8-inch (203-mm) combustion air pipe. Thimble may be required depending on building construction and/or local codes. Larger diameter combustion air pipe serves as clearance for vent pipe on noncombustible construction.
4. Secure longer angles on concentric adapter box brackets (see [Figure 18](#)) to concentric adapter box.

NOTE: The longer angle of the concentric adapter box bracket has five 7/32-inch holes that allow the position of the bracket on the box to be adjusted. The shorter angle has three 7/32-inch holes that allow adjustment to construction.

5. Connect outside section of combustion air pipe to concentric adapter box (see [Figure 23](#)):
 - a. Determine length of combustion air pipe as follows:
 - (1) Bracket length from box to wall
 - (2) Plus wall thickness
 - (3) Plus 2 inches (51 mm) beyond wall
 - b. Secure inlet air pipe to collar of concentric adapter box using sheet metal screws. Seal joint and seam using tape or sealant.
6. Secure concentric adapter box to wall (see [Figure 23](#)):

⚠ CAUTION ⚠

- If the wall is combustible, ensure that brackets are positioned to allow a 2-inch (51 mm) clearance between the concentric adapter box and the wall.
- If any holes are made in the concentric adapter box in error, ensure that they are sealed.

- a. Insert combustion air pipe out through wall.
- b. Secure short angles (see [Figure 18](#)) of concentric adapter box brackets to wall.
- c. Seal or flash inlet air pipe on outside using sealant and/or field-supplied flashing.

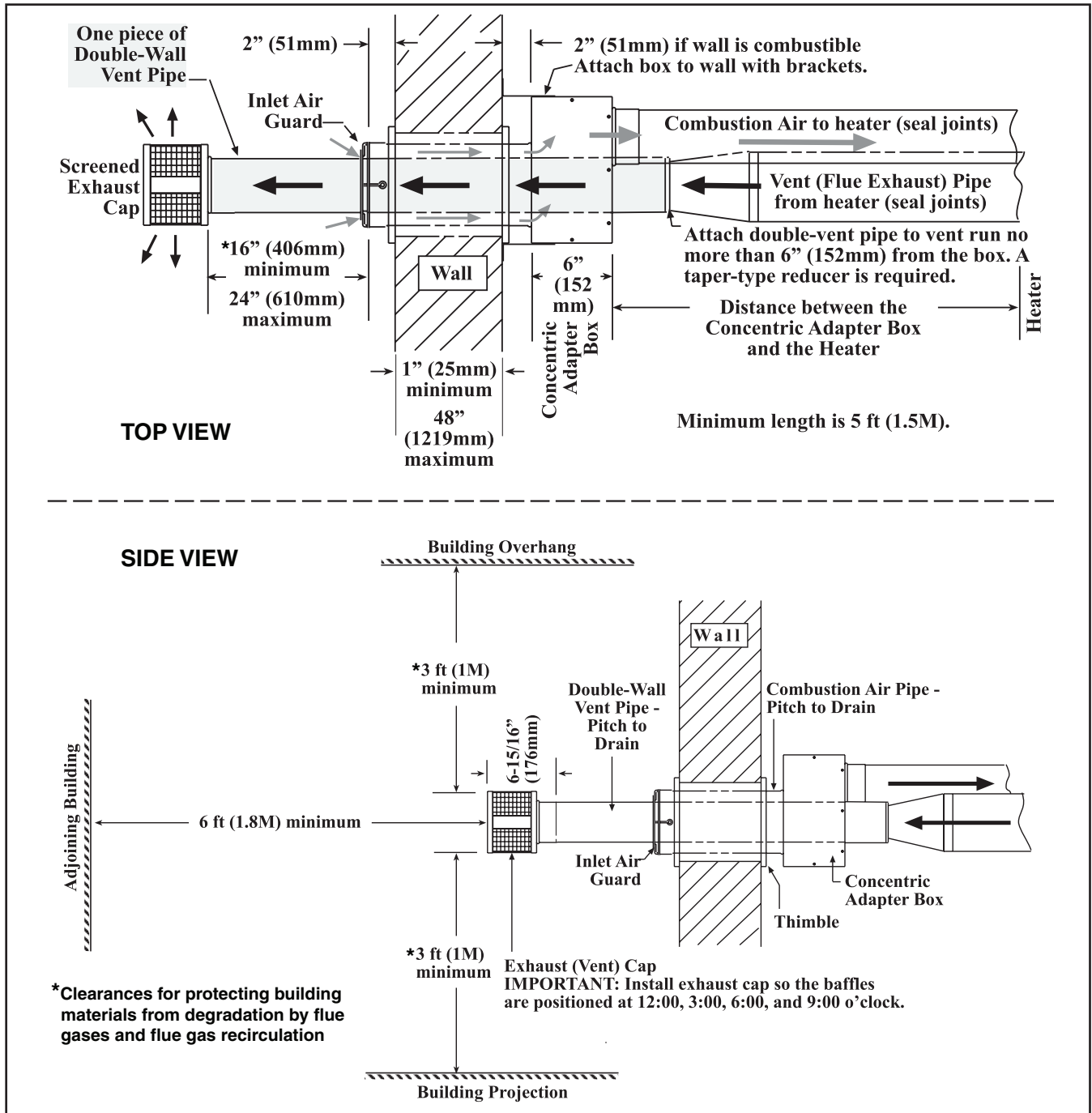

Figure 23. Option CC6 Installation

INSTALLATION—CONTINUED

Venting/Combustion Air Connections—Continued

Horizontal Vent Terminal (Option CC6) Installation—Continued

7. Install inlet guard:

- a. Position inlet guard over end of combustion air pipe in accordance with [Figure 23](#).
- b. Secure air inlet guard to inlet air pipe using four 1/2-inch-long screws provided.

NOTE: If vent pipe is inserted from outside, the exhaust cap may be attached before the double-wall vent pipe is installed. If cap is attached first, ensure that the baffle strips are positioned correctly when attaching the vent terminal pipe to the vent run (refer to step 8d below).

8. Install double-wall terminal vent pipe:

NOTE: The length of the vent pipe is determined by the installation within maximum and minimum requirements. The vent pipe extending through the box and the inlet air pipe must be one piece of double-wall vent pipe without joints.

- a. Refer to [Figure 23](#) to determine lengths of each pipe segment and to calculate total length required. Transition to single-wall or Category III vent pipe run must be made maximum of 6 inches (152 mm) from heater side of box.
- b. Ensure that double-wall terminal vent pipe is in proper direction and slide end of pipe through box. Position pipe so that it will extend between 16–24 inches (406–610 mm) past end of combustion air pipe and no more than 6 inches (152 mm) out of box toward heater.

NOTE: The double-wall vent pipe does not attach to the box. The installer must provide support.

- c. Connect 5-inch double-wall vent pipe to 6- or 7-inch single-wall or Category III vent pipe run using tapered reducer (see [Figure 12](#)).
 - d. Ensure that exhaust cap is aligned so that its baffle strips are positioned on horizontal and vertical center lines (see [Figure 23](#)). Install cap in accordance with [Figure 11](#).
 - e. Ensure that double-wall section of vent pipe has slight downward drop of 1/4-inch per foot (6 mm per 305 mm) toward vent terminal end.
 - f. Seal completely around circumference of pipe and opening of box using silicone sealant.
9. Install indoor section of combustion air pipe:
- a. Secure single-wall combustion air pipe run to collar on concentric adapter box using sheet metal screws. If using 7-inch piping (unit sizes 200–400), install tapered enlarger as shown in [Figure 14](#).
 - b. Seal pipe joints with tape or sealant.
10. Verify compliance with [Figure 23](#) and with all specific venting requirements listed above.

Piping Connections

Gas Supply Pressure

The unit is equipped for a maximum gas supply pressure of 1/2 psi, 3.5 kPa, or 14 IN WC.

NOTES:

Supply pressure higher than 1/2 psi requires the installation of an additional service regulator external to the unit.

PRESSURE TESTING SUPPLY PIPING

- Test pressures *above* 1/2 psi—disconnect the heater and manual valve from the gas supply line to be tested. Cap or plug the supply line.
 - Test pressures *below* 1/2 psi—before testing, close the manual valve on the heater.
-

⚠ DANGER ⚠

- All components of a gas supply system must be leak tested prior to placing equipment in service. NEVER TEST FOR LEAKS WITH AN OPEN FLAME. Failure to comply could result in personal injury, property damage, or death.
- Pipe joint compounds (pipe dope) shall be resistant to the action of liquefied petroleum gas or any other chemical constituents of the gas being supplied.

- All piping must be in accordance with requirements outlined in the *National Fuel Gas Code* ANSI/Z223.1 (latest edition) or the *Natural Gas and Propane Installation Code* CSA B149.1 (refer to [Installation Codes](#) section).
- Gas supply piping installation should conform with good practice and with local codes.
- The heater is orificed for operation with natural gas having a heating value of 1,000 (±50) BTU per cubic foot or with propane gas having a heating value of 2,550 (±100) BTU per cubic foot. Sizing of gas supply lines depends on piping capacity and is based on cubic feet per hour based on a 0.3 IN WC pressure drop, a 0.6 specific gravity for natural gas at 1,000 BTU per cubic feet, and a 1.6 specific gravity for propane at 2,550 BTU per cubic feet. If the gas at the installation does not meet this specification, consult the factory for proper orificing.
- Variables for sizing gas supply lines are listed in [Table 15](#). When sizing supply lines, consider possibilities of future expansion and increased requirements. Refer to *National Fuel Gas Code* for additional information on line sizing.

Table 15. Gas Supply Line Sizes

Length of Pipe (Feet)	Diameter of Pipe (Inches)											
	1/2		3/4		1		1-1/4		1-1/2		2	
	Natural Gas	Propane Gas	Natural Gas	Propane Gas	Natural Gas	Propane Gas	Natural Gas	Propane Gas	Natural Gas	Propane Gas	Natural Gas	Propane Gas
Cubic Feet per Hour												
20	92	56	190	116	350	214	730	445	1100	671	2100	1281
30	73	45	152	93	285	174	590	360	890	543	1650	1007
40	63	38	130	79	245	149	500	305	760	464	1450	885
50	56	34	115	70	215	131	440	268	670	409	1270	775
60	50	31	105	64	195	119	400	244	610	372	1105	674
70	46	28	96	59	180	110	370	226	560	342	1050	641
80	43	26	90	55	170	104	350	214	530	323	990	604
90	40	24	84	51	160	98	320	195	490	299	930	567
100	38	23	79	48	150	92	305	186	460	281	870	531
125	34	21	72	44	130	79	275	168	410	250	780	476
150	31	19	64	39	120	73	250	153	380	232	710	433
175	28	17	59	36	110	67	225	137	350	214	650	397
200	26	16	55	34	100	61	210	128	320	195	610	372

Supply Piping Connections

- Gas connections are shown in [Figure 24](#) and gas connections sizes are listed in [Table 16](#).
- Install a ground joint union and manual shutoff valve upstream of the unit control system. The 1/8-inch plugged tapping in the shutoff valve provides connection for the supply line pressure test gauge. *The National Fuel Gas Code* requires the installation of a trap with a minimum 3-inch drip leg. Local codes may require a longer drip leg, typically 6-inch (see [Figure 24](#)).
- Seal the opening for the gas supply pipe with the grommet provided.
- After all connections are made, disconnect the pilot supply at the control valve and bleed the system of all air. Reconnect the pilot line and leak test all connections by brushing on a soap solution.

INSTALLATION—CONTINUED

Piping Connections—Continued

Supply Piping Connections—Continued

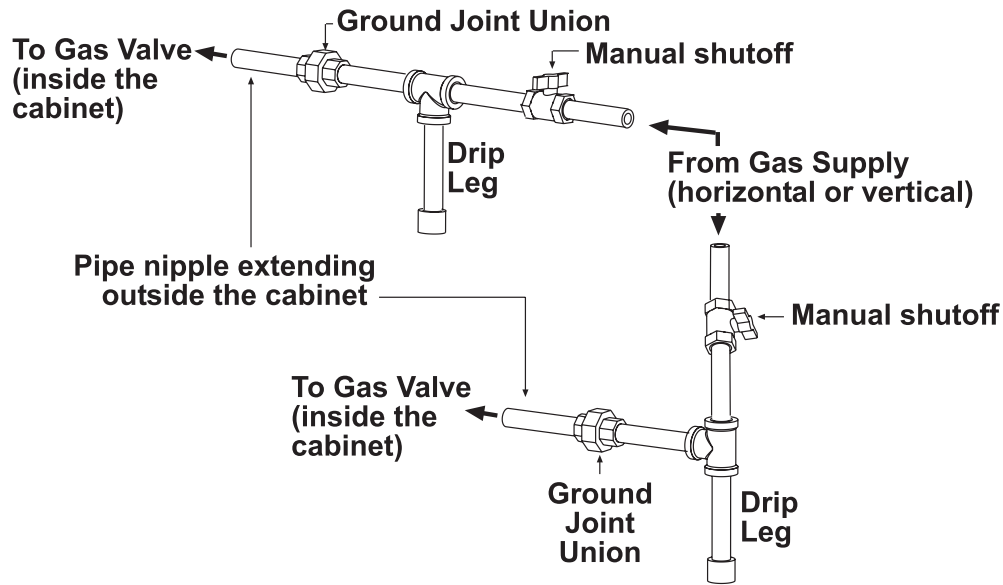

Figure 24. Gas Connections

Table 16. Gas Connection Sizes

Gas Type	Unit Size	
	125–250	300–400
	Connection Size (Inches)	
Natural gas	1/2	3/4
Propane	1/2	

NOTE: The above are not supply line sizes. They are gas connection sizes for a standard unit.

Condensate Drain Installation

Model SC furnaces are certified for installation upstream or downstream from a cooling coil. When installed downstream from a refrigeration system, condensation will form and, therefore, adequate provision must be made to dispose of condensate.

NOTE: A 4-inch (102-mm) minimum clearance is required under the furnace if a 90-degree street elbow is used.

1. Install drain flange (option CS1, PN 31765) in bottom of furnace casing as shown in [Figure 25](#) and secure using two machine screws (#10-32 × 1-inch-long) and nuts.
2. Install 3/4-inch waste pipe nut in drain flange.
3. Seal all corners and four square holes in bottom pan edge using RTV sealant.
4. Terminate drain outside of building and provide trap to prevent air from entering combustion zone.

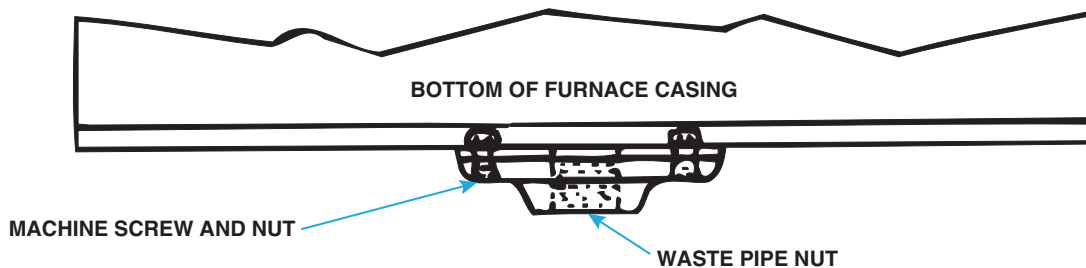

Figure 25. Condensate Drain Connection

NOTE: Periodic cleaning of the condensate collector and disposal system is required.

Electrical Connections

⚠ CAUTION ⚠

If any of the original wire as supplied with the appliance must be replaced, it must be replaced with wiring material having a temperature rating of at least 105°C, except for the sensor lead and the optional bypass damper combustion air safety circuit (option AG39 or AG40) wires, which must be rated at 150°C.

NOTES:

- Ensure that all wiring is in accordance with the wiring diagram provided with the unit. A specific wiring diagram can be found in the heater junction box. Electrical options are identified on this wiring diagram.
- Refer to separate instruction sheets for any optional equipment provided.
- All electrical wiring must be completed in accordance with local, state, and national codes and regulations and with the *National Electric Code* (ANSI/NFPA 70) or, in Canada, the *Canadian Electric Code*, Part 1 (CSA C.22.1).
- Check any local ordinances or gas company requirements that apply.
- Check the rating plate on the heater for the supply voltage and for current requirements. A separate line voltage supply with fused disconnect switch should be run directly from the main electrical panel to the unit, making connections in the junction box.
- Seal all electrical entrance openings with field-supplied bushings (see [Figure 1](#)). Refer to [Table 17](#) for field-supplied wiring sizes—from disconnect to electrical box—for connection to the motor contactor or starter.

Table 17. Field-Supplied Wiring Sizes

Voltage/Phase	Motor HP	Wire Gauge	BX Cable
120/1	1/4– 1/2	14	3/8
208–230/1	1	12	3/8
	1–1-1/2	14	3/8
208–230/3	1/4–3	14	3/8
460/3	5	12	3/8
	1/4–5	14	3/8
575/3	1/2–5	14	3/8

- A disconnect switch is available as optional equipment or may be provided locally. When installing the disconnect switch, ensure that the conduit and switch housing are clear of all service panels. Allow at least 4 feet (1.2 meters) of service room between the disconnect switch and any removable service panels. When providing or replacing fuses in a fusible disconnect switch, use dual-element time delay fuses sized at 1.25 × maximum total input amps.

Control Wiring

- The heater is equipped with a low-voltage (24V) control circuit. Refer to [Table 18](#) for field-supplied control wiring sizes.

Table 18. Field-Supplied Control Wiring Sizes

Distance from Unit to Control (Feet (Meters))	Minimum Recommended Wire Gauge (AWG)	Total Wire Length (Feet (Meters))
75 (23)	#18	150 (46)
125 (38)	#16	250 (76)
175 (53)	#14	350 (107)

INSTALLATION—CONTINUED

Electrical Connections—Continued

Control Wiring—Continued

- Refer to [Table 19](#) for amp ratings of optional controls.

Control	Ampere Rating (Amps)
Fan control coil	0.12
Time delay heater	0.14
RBM relay coil	0.12
Contactor coil	0.45
Spark ignition system	0.10
Maxitrol gas control system	0.51
Honeywell gas valve	0.50
White-Rodgers gas valve	0.60

CONTROLS

Thermostat

⚠ CAUTION ⚠

Control circuit amps should be within the anticipator amp rating of the thermostat used.

- A thermostat is not provided with the furnace. Use either an optional or a field-provided low-voltage (24V) thermostat. Install the thermostat according to the manufacturer's instructions.
- A low-voltage thermostat is equipped with a heat anticipator that levels out unit cycling for optimum temperature control. Set the anticipator at 1.0 amps for standard controls.

Combustion Air Proving Switch

⚠ DANGER ⚠

Safe operation requires proper venting flow. Never bypass the combustion air proving switch or attempt to operate the unit without the venter running and proper flow in the vent system. Hazardous conditions could result.

- The combustion air proving switch ensures that proper combustion airflow is available. The switch is a single-pole, double-throw switch that senses pressure caused by the flow of combustion air from the venter. The switch is designed to close when a decreasing pressure is sensed in the outlet duct of the gas collection box.
- At startup when the furnace is cold, the sensing pressure is at the most negative level. As the furnace and the flue system warm up, the sensing pressure becomes less negative. After the system has reached equilibrium (approximately 20 minutes), the sensing pressure levels off. If a restriction or if excessive flue length or turns cause the sensing pressure to become less than the switch setpoint, the pressure switch will function to shut off the main burners. The main burners will remain off until the system has cooled and/or the flue system resistance is reduced. Refer to [Table 20](#) for approximate water column negative pressure readings and combustion air proving switch setpoints for sea level operating conditions.

Unit Size	Factory Setpoint	Startup Cold	Equilibrium
Units Without Option AG39 or AG40			
All	-0.58 (±0.05) IN WC	-1.0 IN WC	-0.70 IN WC
Units with Option AG39 or AG40			
100–225	-0.80 (±0.05) IN WC	-1.30 (±0.20) IN WC	-1.05 (±0.10) IN WC
250, 300, 400	-0.70 (±0.05) IN WC	-1.20 (±0.20) IN WC	-0.95 (±0.10) IN WC

Blower Fan Control

NOTE: For units manufactured before *before* OCT 2003, the fan control was optional. To replace the blower fan control on units manufactured *before* NOV 2004, a replacement kit (PN 209184) is required.

The field-supplied blower fan is controlled as follows:

- After the gas valve opens, there is a time delay of blower fan operation to prevent the discharge of cold air.
- Blower fan operation continues after the [thermostat](#) is satisfied, as determined by the fan time delay.
- To ensure that the blower fan can continue to operate, the power supply to the furnace MUST NOT be interrupted except for when servicing the unit.

NOTE: If the customer wants the furnace off at night, the gas valve circuit SHOULD BE OPENED by a single-pole switch wired in series with the [thermostat](#). Some thermostats are provided with this feature. Multiple units controlled from a single [thermostat](#) are shut off in the same manner. For proper operation, ensure that the blower fan control is wired correctly.

Limit Control

All models are equipped with an automatic, non-adjustable, reset limit control that acts to interrupt the electric supply to the redundant main operating valve in case of motor failure or lack of airflow due to restrictions at the inlet or outlet.

Variable Frequency Drive

- If the system is equipped with an optional variable frequency drive, the motor will operate at speeds determined by the electrical frequency: 60 Hertz (Hz) is maximum speed. Speed must be within the temperature rise range of a model SCE series 6 heater: 30–90°F.
- Follow the variable frequency controller manufacturer's instructions that are packaged with the heater (in the owner's envelope) to program the variable frequency drive settings. The formula for motor speed is $N = 120 \times f/p$ where N = speed, f = frequency, p = number of poles, a 3,600-rpm motor has two poles, and an 1800-rpm motor has four poles. For example, for an 1,800-rpm motor at 60Hz, $N = 120 \times 60/4 = 1800$ (1,800 = synchronous speed, assume 2% slip).
- The motor will run between 1,750 and 1,790 rpm at full load depending on design. For the same motor run at 45Hz, $120 \times 45/4 = 1350$ (1,350 rpm less 2% slip = about 1,300 rpm).

Combination Gas Valve

WARNING

The combination gas valve is the prime safety shutoff. To ensure positive closure, all gas supply lines must be free of dirt or scale before connecting them to the unit.

All furnaces are equipped with a 24V combination gas valve that includes the automatic electric ON/OFF valve controlled by the room [thermostat](#), the pressure regulator, the safety pilot valve, and the manual shutoff valve. The standard combination gas valve allows for single-stage control from a single-stage, 24V [thermostat](#).

Optional Two-Stage Control (Heating Only Application)

The standard combination control valve is replaced with a two-stage combination gas control valve providing for low fire or high fire operation controlled by a two-stage [thermostat](#). The first stage (low fire) is factory-set (not field-adjustable). Both low fire and high fire stages are controlled by a Servo regulator that maintains constant gas input under wide variations in gas supply pressure. Refer to the instructions provided with the unit for gas valve specifications, wiring, and operating instructions.

CONTROLS—CONTINUED

Optional Two-Stage Control (Makeup Air Application)

- Two-stage makeup air units are equipped with a two-stage gas valve, but instead of control from a two-stage room [thermostat](#), the outlet air temperature is monitored and controlled by a two-stage ductstat. When discharge air temperature drops to the setpoint, low fire is energized. If low fire cannot satisfy the ductstat setting, high fire is energized.
- Makeup air applications are usually adjusted to maintain discharge air temperature between 65°F and 75°F. In all applications, the allowable temperature rise of the furnace in the installation dictates the limits of the ductstat temperature setting.
- Depending on the option selection, the factory-installed sensor is either field-connected by capillary tubing to the unit-mounted ductstat (see [Figure 26](#)), which is factory-set at 70°F, or electrically-connected to a remote electronic temperature selector (see [Figure 27](#)).



Figure 26. Unit-Mounted Ductstat (Option AG3)

Optional Ductstat with Capillary Tubing (Option AG3)

The unit-mounted ductstat shown in [Figure 26](#) has an adjustable range between 0°F and 100°F with a fixed differential of 3°F. Due to different cfm settings and outside air temperatures, the average downstream outlet temperature may not match the ductstat setting exactly. After the installation is complete, adjust the setpoint of the ductstat to achieve the desired average outlet air temperature.



A = TEMPERATURE-SELECTING MODULE
B = ONE-STAGE ADDER MODULE

Figure 27. Remote Temperature Selector (Option AG15)

Optional Ductstat with Electronic Remote Setpoint Module (Option AG15)

The sensing probe is field-wired to the remote temperature selector shown in [Figure 27](#), which has a temperature operating range to 120°F. The remote modules and sensing probe are shipped separately for field-installation. Follow the wiring diagram provided with the unit and the manufacturer's instructions for wiring and installation. One module is for selecting temperature and the other is a one-stage adder module.

⚠ CAUTION ⚠

Ensure that the heat/cool selector switch on the remote temperature selector is positioned to *Heat*.

Optional Electronic Modulation

NOTE: Unit sizes 350 and 400 with electronic modulation require a minimum natural gas supply pressure of 6 IN WC.

- Depending on heat requirements established by the thermistor sensor, the burner modulates between 100% and 50% firing. The thermistor is a resistor that is temperature sensitive in that as the surrounding temperature changes, the resistance (ohms) changes through the thermistor. This change is monitored by the solid-state control center (amplifier), which provides a varying DC current to the modulating valve to adjust the gas input.
- Each modulating valve is basically a regulator with electrical means of raising and lowering discharge pressure. When no DC current is available to this device, it functions as a gas pressure regulator that supplies 3.5 IN WC pressure to the main operating valve.
- Refer to the wiring diagram provided with the furnace for proper wiring connections for the electronic modulation system.
- The type and capability of the electronic modulation system, depend on the option selected.

Electronic Modulation Between 50% and 100% Firing Rate (Option AG7, AG8, or AG9)

- Electronic modulation for heating that is controlled by a specially-designed room [thermostat](#) (60–85°F) is identified as option AG7.
- Electronic modulation for makeup air application that is controlled by a duct sensor and temperature selector (55–90°F) is identified as option AG8 or AG9. The temperature selector setting for option AG8 is on the amplifier (see [Figure 28](#)). Option AG9 has a remote temperature selector. Both systems are available with an override [thermostat](#).



AMPLIFIER

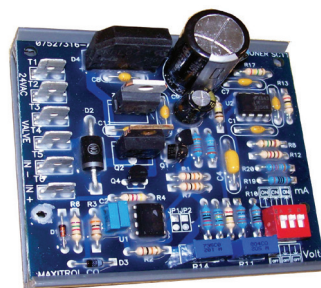

SIGNAL CONDITIONER

Figure 28. Maxitrol Amplifier and Signal Conditioner

CONTROLS—CONTINUED

Optional Electronic Modulation—Continued

Computer-Controlled Electronic Modulation Between 50% and 100% Firing Rate (Option AG21)

- With option AG21, the furnace is equipped with a Maxitrol signal conditioner (see [Figure 28](#)) that operates much the same way as the amplifier above to control the regulator valve. The signal conditioner accepts an input signal of either 4–20 milliamps or 0–10V from a customer-supplied control device such as a computer.
- With the dip switches on the conditioner positioned to ON, the conditioner accepts a 4–20 milliamp signal. With the dip switches on the conditioner positioned to OFF, the conditioner accepts a 0–10V signal. The conditioner converts the signal to the 0–20V DC current required to control the modulating valve.

Electronic Modulation Between 20–28% and 100% Firing Rate (Option AG39)

NOTE: Option AG39 (US Patent 6,109,255) is available only with natural gas and is not available on unit size 350.

- Depending on its size, a furnace equipped with option AG39 has a 20–28% turndown ratio. The furnace will ignite at any input rate in the available range and will maintain average thermal efficiencies equal to or greater than the thermal efficiency at full fire.
- The gas train (see [Figure 29](#)) includes a single-stage gas valve, a modulating valve, and two gas pressure switches. The burner rack is equipped with one flash carryover and a regulated gas lighter tube system. The carryover lighter tube receives its gas supply through the regulator simultaneously with the gas to the burner. Control of the system is through a Maxitrol amplifier (see [Figure 28](#)) with a corresponding remote temperature dial.

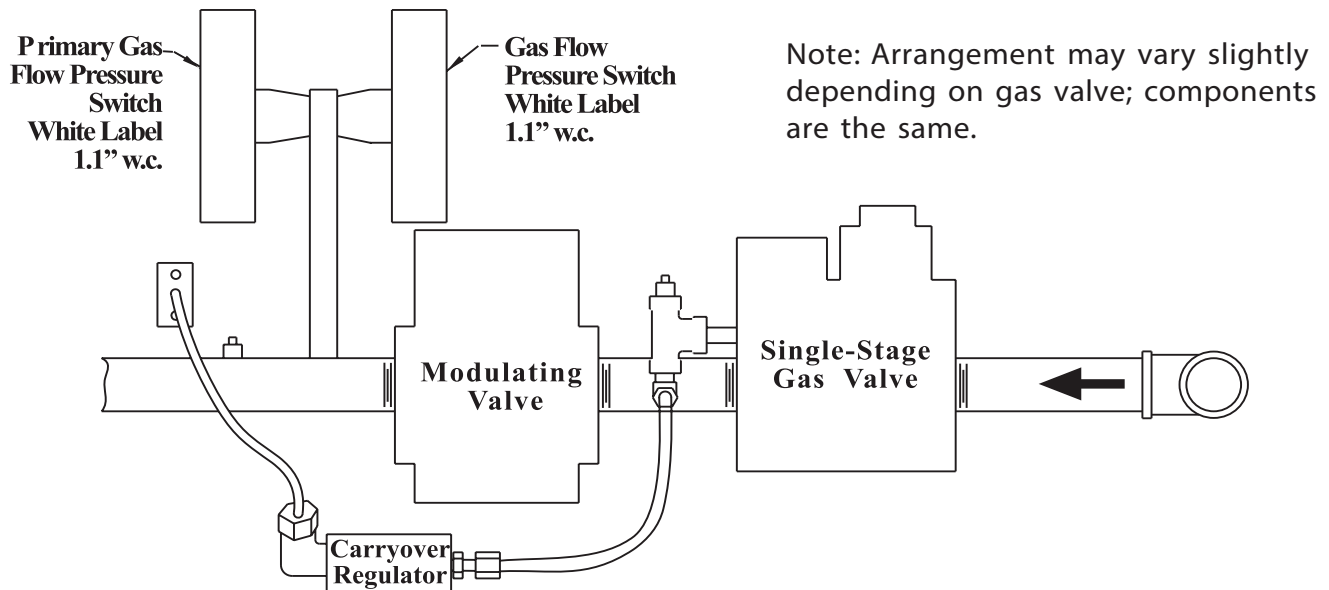

Figure 29. Option AG39 Manifold Arrangement

- The gas supply (refer to pressure requirements in **Table 21**) connects to the single-stage gas valve. To compensate for additional pressure loss through the modulating valve, the single-stage gas valve has a custom outlet pressure setting higher than when it is used on a standard gas manifold. The pilot tubing connects to the pilot port on the single-stage gas valve.
- When the valve receives a call for heat from the amplifier and pilot is established, gas flow from the single-stage valve goes to both the modulating valve and the regulated lighter tube system. When the signal from the amplifier to the modulating valve requires less-than-high fire operation, the modulating valve functions to lessen the gas flow to the burner to reduce the input rate to that which is necessary to maintain the desired temperature. When the input rate is reduced enough to decrease the gas pressure to 1.1 IN WC, the primary gas pressure switch in the manifold activates the gear motor that controls the bypass damper in the venter/combustion air system. The bypass damper opens to divert some of the incoming air directly into the flue duct to reduce air flow through the burner. Safety switches monitor the position of the bypass damper. When the gas pressure rises to >1.1 IN WC, the bypass damper closes.
- **Sensor location:** The duct temperature sensor is shipped loose for field installation (refer to **CONTROLS** section to determine sensor location).
- This uniquely-designed modulation system requires combustion air pressure settings different from the standard system. Refer to **Table 20** for the approximate combustion air proving switch settings at sea-level operation.

Electronic Modulation Between 20–28% and 100% Firing Rate (Option AG40)

NOTE: Option AG40 (US Patent 6,109,255) is available only with natural gas and is not available on unit size 350.

- With option AG40, the furnace is equipped with a Maxitrol signal conditioner (see **Figure 28**) that receives an input signal of either 4–20 milliamps or 0–10V from a customer-supplied control device such as a computer. With the dip switches on the conditioner positioned to ON, the conditioner accepts a 4–20 milliamp signal. With the dip switches on the conditioner positioned to OFF, the conditioner accepts a 0–10V signal. The conditioner converts the signal to the 0–20V DC current required to control the modulating valve. The heater functions and is equipped in the same way as option AG39 except that with computer control, the temperatures are selected through the software and there is no temperature selector or duct sensor.
- Refer to **Table 21** for option AG40 pressure requirements and to **Figure 30** for troubleshooting option AG40.
- This uniquely-designed modulation system requires combustion air pressure settings different from the standard system. Refer to **Table 20** for the approximate combustion air proving switch settings at sea-level operation.

Table 21. Options AG39 and AG40 Pressure Requirements

Unit Size	Maximum Turndown (%)	Input Range (MBH)	Factory-Set Inlet Pressure to Modulating Valve (IN WC)	Required Gas Supply Pressure (IN WC)
100	20	20–100	3.8	5.0
125	20	25–125	3.9	5.0
150	27	40.3–150	3.7	5.0
175	23	40.3–175	3.7	5.0
200	26	51.8–200	3.9	5.0
225	23	51.8–225	3.9	5.0
250	28	69–250	4.0	5.0
300	23	69–300	4.0	5.0
400	25	100–400	4.4	6.0

CONTROLS—CONTINUED

Optional Electronic Modulation—Continued

Electronic Modulation Between 20–28% and 100% Firing Rate (Option AG40)—Continued

General Instructions: For each step, check to ensure that the wiring is not defective and that the wiring connections are secure.

Symptom - Part 1:

Main burners are inoperative. Assumes that 24 volts is available between Terminal 2 and Terminal 7.

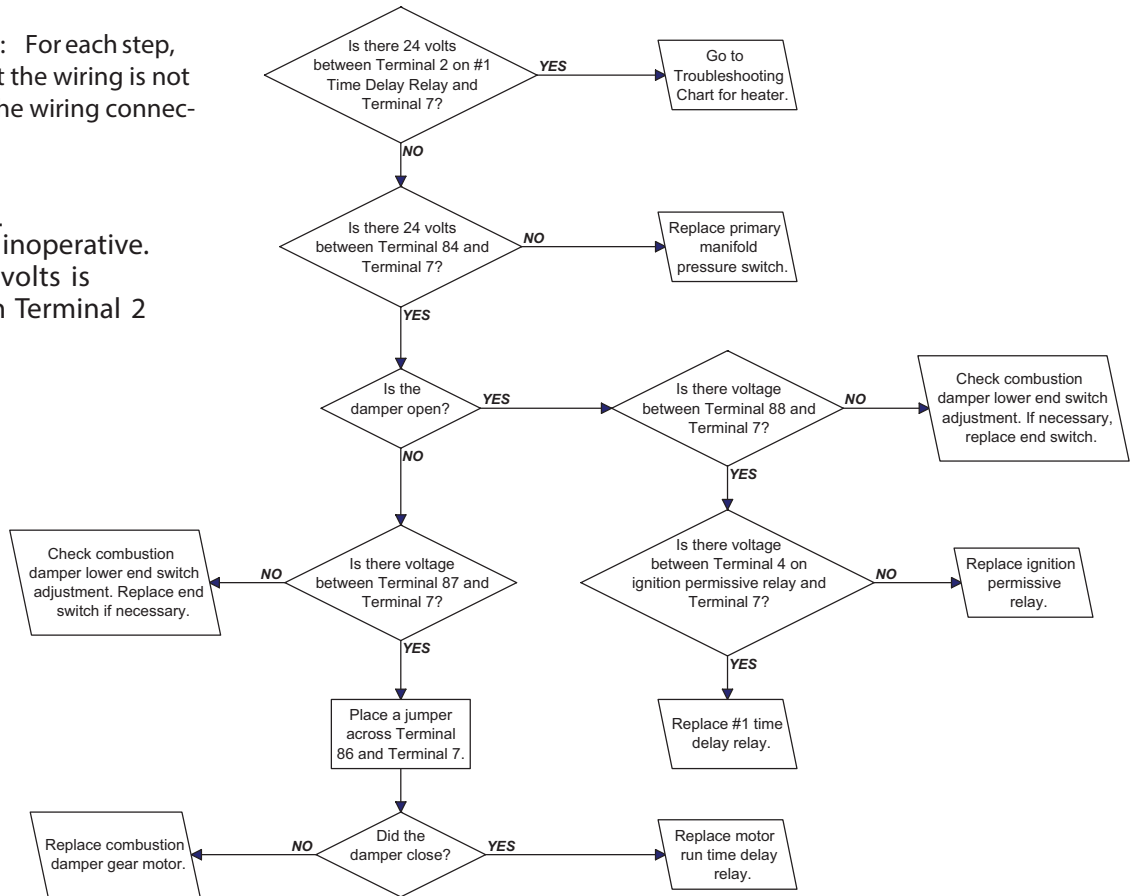

Symptom - Part 2:

Steady call for heat - burner cycles.

Assumes that 24 volts is available between Terminals 11 and 7 and Terminals 2 and 7.

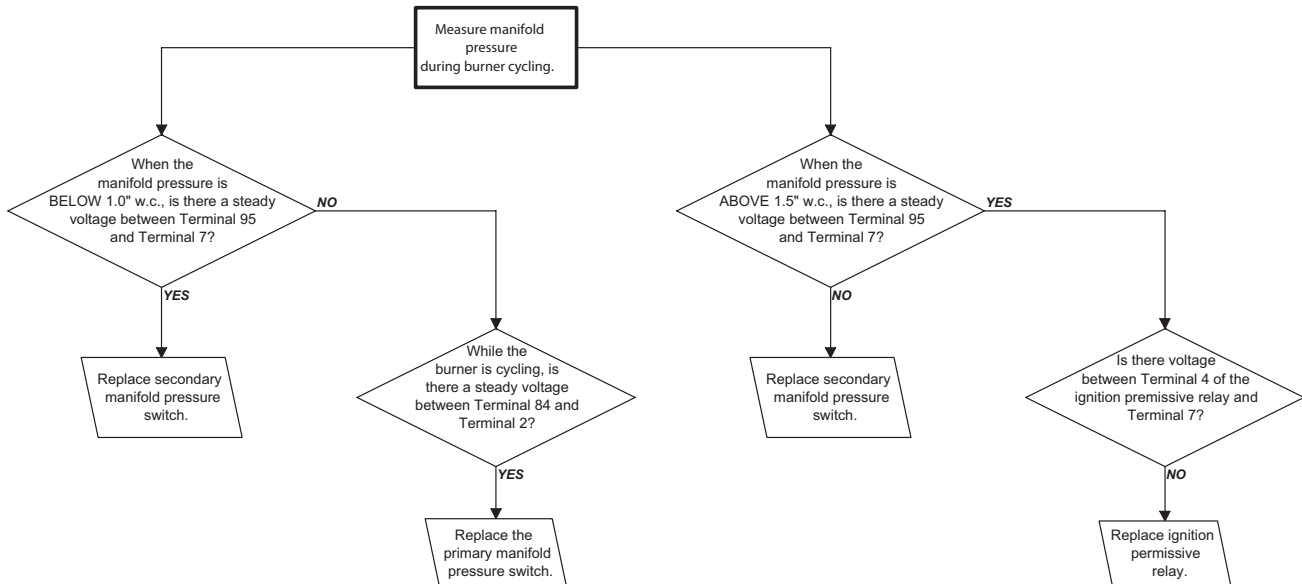

Figure 30. Troubleshooting Guide for Checking Bypass Combustion Air Damper Safety Circuit on Units with Option AG39 or AG40

Pilot and Ignition Systems

⚠ WARNING ⚠

Due to high voltage on the pilot spark wire and pilot electrode, do not touch when energized.

- **Pilot:** All pilots are vertical, target-type with a lint-free feature. Pilot flame should be approximately 1-1/4 inches in length. Pilot gas pressure should be the same as the supply line pressure. Pilot gas is supplied through the combination valve. Pilot gas flow is controlled by an adjustment screw located in the valve body. For maintenance, refer to [Burner Rack Maintenance](#) and [Cleaning Pilot and Burners](#) sections.
- **Ignition system:** Natural gas units are equipped with a spark-ignited intermittent safety pilot system that shuts off the pilot gas flow between heat cycles. Propane units (or as an option on natural gas units) require a lockout device that stops the gas flow to the pilot if the pilot fails to light in 120 seconds. The lockout device has a 1-hour retry or can be manually reset by interruption of the [thermostat](#) circuit. Refer to the wiring diagram provided with the unit for pilot system identification and proper wiring. Pilot with lockout is option AH3. Spark pilot without lockout is option AH2.
- **Ignition controller:** As part of the intermittent safety pilot system, the ignition controller provides high voltage spark to ignite pilot gas and also acts as the flame safety device. After ignition of the pilot gas, the ignition controller electronically senses the pilot flame. A low voltage DC electrical signal is imposed on the separate metal probe in the pilot assembly. The metal probe is electrically insulated from ground. The pilot flame acts as a conduction path to ground to complete the DC circuit and prove pilot flame. Proper operation of the electronic spark ignition system requires a minimum flame signal of 0.2 microamps, as measured by a microampmeter. With pilot flame proven, the ignition controller energizes the main gas valve.

Burners, Burner Orifices, and Carryover System

NOTE: Natural gas units have a dual flash carryover system and do not require a carryover orifice.

- **Burners:** Individually-formed steel burners capable of operating on either natural or propane gas are used in this heater. These burners have accurate, machine-formed ports to provide controlled flame stability and operation without lifting or flashback. All burners are lightweight and are factory-mounted in an assembly that permits all of the burners to be removed as a unit for inspection or service.
- **Burner orifices:** Heaters are shipped with burner orifices of proper size and type for the specified gas. Refer to [Table 22](#) for burner and carryover orifice specifications.

Table 22. Burner and Carryover Orifice Specifications

Unit Size	Burner Orifice						Carryover Orifice	
	Quantity	Natural Gas		Propane Gas		Propane Gas		
		PN	Drill Size	PN	Drill Size	PN	Drill Size	
100	4	11792	#41	61652	1.45 mm	9870	#70	
125	5	84437	#42	61652	1.45 mm	9870	#70	
150	7	11833	#44	11830	#55	9680	#65	
175	7	84437	#42	61652	1.45 mm	9680	#65	
200	9	11828	#43	11830	#55	9680	#65	
225	9	84437	#42	61652	1.45 mm	9680	#65	
250	12	11833	#44	11830	#55	10370	#59	
300	12	84437	#42	61652	1.45 mm	10370	#59	
350	14	84437	#42	61652	1.45 mm	9791	#56	
400	16	84437	#42	61652	1.45 mm	9791	#56	

- **Burner Carryover Systems:** All natural gas burners, except when equipped with electronic modulation option AG39 or AG40, are equipped with two flash carryover systems—one on each end of the burner rack.

CONTROLS—CONTINUED

Burners, Burner Orifices, and Carryover System—Continued

NOTE: Natural gas burner racks on furnaces manufactured *before* series 6 units have a gas lighter tube carryover and one flash carryover. All propane gas burners are equipped with one flash carryover and a regulated gas tube system. The carryover lighter tube receives its gas supply through a regulator simultaneously with the gas to the burner orifices.

- During regular service, check the main burner ports, the carryover assemblies, and the orifices for cleanliness.
- Typical natural gas and propane gas burner racks are shown in [Figure 31](#).

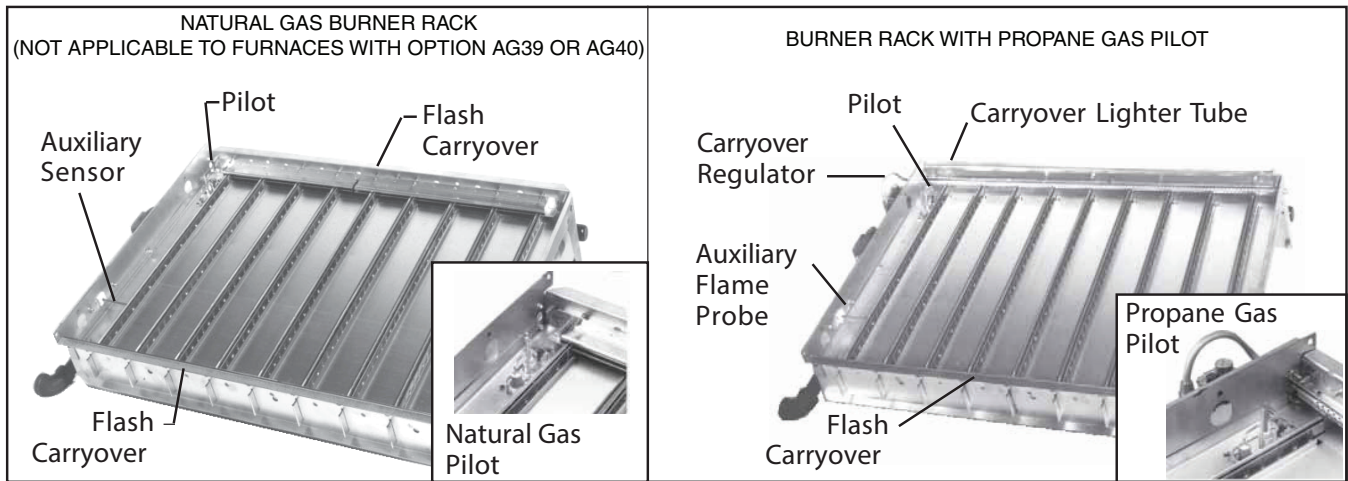

Figure 31. Typical Burner Rack

OPERATION

⚠ WARNING ⚠

To ensure safety, follow the lighting instructions located on the outlet box cover.

Pre-Startup Checklist

• Installation checks:

- Verify suspension/mounting methods and clearances (refer to [Suspension](#), [Mounting](#), and [Clearances](#) sections)
- Verify that bolts removed from shipping clips have been returned to heater cabinet (refer to [Uncrating/Unpacking](#) section)
- Check duct connections (refer to [Duct Connections](#) section)
- Check venting (refer to [Specific Venting Requirements: Piping](#) section) and ensure that flue discharge and combustion air openings are free of obstructions
- Ensure that electrical entrance and gas supply pipe openings are sealed
- Ensure that all condensate drains are open (refer to [Condensate Drain Installation](#) section)

• **Electrical checks:**

- Ensure that electrical supply is in accordance with voltage rating on unit's rating plate
- Ensure that all field wiring is in accordance with wiring diagram and that wire gauges are as required for electrical load
- Ensure that fuses or circuit breakers are in place and are sized correctly

• **Gas supply checks:**

- Check piping for leaks and proper gas line pressure and bleed trapped air from gas lines (refer to **Supply Piping Connections** section)
 - a. Turn OFF manual shutoff valve.
 - b. Turn ON gas supply.
 - c. Observe gas meter for movement or attach pressure gauge readable to 0.1 IN WC and, after turning gas ON for 10 seconds, turn OFF gas supply—no change in pressure should occur over 3-minute period.
 - d. If step c indicates leak, locate leak by brushing soapy solution on all fittings—bubbles will appear at any leaks.
 - e. Repair any leaks and repeat test.

Startup

1. Close all panels tightly.
2. Turn ON electric and gas supply to furnace.
3. Adjust **thermostat** or ductstat so that call for heat exists.
4. Observe for complete sequencing of safety pilot and ignition (refer to **Table 23**).

NOTE: On units equipped with a controller that includes lockout control, if the pilot is not established within 120 seconds (approximately), the unit locks out for 1 hour or must be reset by interrupting the power to the control circuit (refer to lighting instructions on unit).

Table 23. Sequence of Operation

Step	Action	Observe
1	Set thermostat at its lowest setting	
2	Turn ON electric and gas supply to furnace	
3	Turn ON manual gas valves	
4	Set thermostat at desired setting— thermostat calls for heat	Venter motor is energized after 15-second (approximate) time delay
		Venter flow switches from NC to NO contacts to energize pilot gas valve and spark gap to produce pilot flame on each operating cycle
		Sensing probe proves presence of pilot flame and energizes safety switch portion of control to deenergize spark gap and energize main valve
		Main gas ignites and unit fires at full rate
	If flame is extinguished during main burner operation, safety switch closes main valve and recycles spark gap	Thermostat is satisfied
		Solenoid gas valve is deenergized
Pilot gas valve is deenergized		
	Ignition controller is deenergized	
	Time delay relay keeps venter motor on for approximately 1 minute (post-purge)	
5	To shut down, set thermostat to lowest setting	

OPERATION—CONTINUED

Post-Startup Checklist

- ❑ Observe burner flame at full fire. Natural gas flame should be about 1-1/2 inches in height with blue coloring. Propane gas flame should be approximately same height with blue coloring. Yellow tipping may appear on propane gas. If yellow extends beyond 1/2- to 3/4-inch, adjust air shutters (refer to [Burner Air Shutter Adjustment](#) section). If shutter adjustment does not reduce yellowing, check for gas leaks at control manifold or orifice fitting.
- ❑ Turn unit OFF and ON, pausing 2 minutes between each cycle. Observe to verify smooth ignition. On two-stage or modulating burner systems, manipulate temperature adjustment slowly up and down to see if control is sequencing or modulating properly. Raising temperature setting drives burner on or to full fire.
- ❑ Using manometer or slant gauge readable up to 14 IN WC, check orifice manifold for operating pressure on full fire. Natural gas should be 3.5 IN WC at this point. Propane gas should be 10 IN WC at this point. Variations from these pressures are not recommended as ignition and efficiency performance can be adversely affected by improper pressure adjustment (refer to [Measure and Adjust Manifold \(Outlet\) Gas Pressure](#) section).
- ❑ Place owner's envelope containing Limited Warranty Card, this manual, and any optional information in accessible location near heater. Follow instructions on envelope.

⚠ DANGER ⚠

- **The gas burner in this gas-fired equipment is designed and equipped to provide safe, controlled, complete combustion. However, if the installation does not permit the burner to receive the proper supply of combustion air, complete combustion may not occur. The result is incomplete combustion, which produces carbon monoxide, a poisonous gas that can cause death.**
- **Safe operation of separated-combustion, indirect-fired gas burning equipment requires a sealed, properly-operating vent system that vents all flue products to the outside atmosphere. FAILURE TO PROVIDE PROPER VENTING WILL RESULT IN A HEALTH HAZARD THAT COULD CAUSE SERIOUS PERSONAL INJURY OR DEATH.**
- **Install either the horizontal (see [Figure 23](#)) or vertical (see [Figure 17](#)) combustion air/vent system using the concentric adapter provided. Always comply with the combustion air requirements in the installation codes and instructions.**
- **Combustion air at the burner should be regulated only by manufacturer-provided equipment. NEVER RESTRICT OR OTHERWISE ALTER THE SUPPLY OF COMBUSTION AIR TO ANY HEATER. CHECK THE COMBUSTION AIR/VENT SYSTEM FOR SOUNDNESS AND FUNCTION AND MAINTAIN IT IN PROPER OPERATING CONDITION.**

ADJUSTMENTS

Measure and Adjust Manifold (Outlet) Gas Pressure

Measuring manifold gas pressure cannot be done until the heater is in operation (refer to [OPERATION](#) section).

- **For natural gas:** When the heater leaves the factory, the combination valve is set so that the outlet gas pressure of a single-stage valve or high fire of a two-stage valve is regulated to 3.5 IN WC. Low fire on a two-stage valve is set to 1.8 IN WC. Inlet supply pressure to the valve must be a minimum of 5 IN WC or as noted on the rating plate and a maximum of 14 IN WC.

NOTE: Always check the rating plate for minimum gas supply pressure.

- **Minimum natural gas supply pressure:** Requirements vary based on size of burner and the gas control option. Most units require a minimum of 5 IN WC natural gas as stated above, but sizes 350 and 400 with electronic modulation require a minimum of 6 IN WC natural gas supply pressure.

- **For propane gas:** When the heater leaves the factory, the combination valve is set so that the outlet gas pressure of a single-stage valve or high fire of a two-stage valve is 10 IN WC. Low fire on a two-stage valve is set to 5 IN WC. Inlet pressure to the valve must be a minimum of 11 IN WC and a maximum of 14 IN WC.

⚠ WARNING ⚠

- **Manifold gas pressure must never exceed 3.5 IN WC for natural gas or 10 IN WC for propane gas.**
 - **Before attempting to measure or adjust manifold gas pressure, the inlet (supply) pressure must be within the specified range for the gas being used, both when the heater is in operation and when it is on standby. Incorrect inlet pressure could cause excessive manifold gas pressure immediately or at some future time.**
-

NOTE: A manometer (fluid-filled gauge) is recommended rather than a spring-type gauge due to the difficulty of maintaining calibration of a spring-type gauge.

1. With the manual valve (on the combination valve) positioned to prevent flow to the main burners, connect a manometer to the 1/8-inch pipe outlet pressure tap in the valve.
 2. Open the valve and operate the heater. Measure the gas pressure to the manifold. To measure the low-stage pressure on units equipped with a two-stage valve, disconnect the wire from the HI terminal on the valve. Be sure to reconnect the wire.
-

⚠ CAUTION ⚠

DO NOT bottom out the gas valve regulator screw. This can result in excessive overfire and heat exchanger failure due to unregulated manifold pressure.

3. Normally, adjustments to the factory-preset regulator should not be necessary. If adjustment is necessary, set pressure to correct settings by turning the regulator screw IN (clockwise) to increase pressure or OUT (counterclockwise) to decrease pressure. Consult the valve manufacturer's literature provided with the furnace for more detailed information.
-

High Elevation (>2,000 Feet/609 Meters) Installations

NOTES:

- **High elevation (>2,000 feet/609 meters) application with this unit depends on the installation elevation and the heating value of the gas. At high elevations, the heating value of natural gas is always lower than the heating value at sea level.**
 - **Deration is necessary to compensate for low atmospheric pressure at high elevations. Generally this will require obtaining the gas heating value from the local gas utility and replacing the burner orifices.**
-

For high elevation (>2,000 feet/609 meters) installations that require orifice replacement, replace the burner orifices as follows:

1. Determine model number and rated input (BTUh) from unit's rating plate.
2. Determine appropriate orifice replacement (refer to [Table 24](#)) for installation elevation.

ADJUSTMENTS—CONTINUED

Measure and Adjust Manifold (Outlet) Gas Pressure—Continued

High Elevation (>2,000 Feet/609 Meters) Installations—Continued

Installation Elevation (Feet (Meters))	Installation Location	Unit Size	Natural Gas		Propane	
			PN	Orifice Size	PN	Orifice Size
2001–3000 (611–915)	US	100, 125, 175, 225, 300, 350, 400	84437	#42	11834	#54
		150, 250	38678	#45	11830	#55
		200	11833	#44	11830	#55
2001–4500 (611–1373)	Canada	100	84437	#42	11834	#54
		125, 175, 225, 300, 350, 400	11828	#43	11834	#54
		150, 250	38678	#45	11830	#55
3001–4000 (916–1220)	US	100	84437	#42	11834	#54
		125, 175, 225, 300, 350, 400	11828	#43	11834	#54
		150, 250	38678	#45	11830	#55
4001–5000 (1221–1525)	US	200	11833	#44	11830	#55
		100	84437	#42	11834	#54
		125, 175, 225, 300, 350, 400	11828	#43	11834	#54
5001–6000 (1526–1830)	US	150, 250	38678	#45	11830	#55
		100, 125, 175, 225, 300, 350, 400	11828	#43	97360	1.35 mm
		200	38678	#45	39658	#56
6001–7000 (1831–2135)	US	100	11828	#43	97360	1.35 mm
		125, 175, 225, 300, 350, 400	11833	#44	97360	1.35 mm
		150, 250	84853	#47	39658	#56
7001–8000 (2136–2440)	US	200	38678	#45	39658	#56
		100, 125, 175, 225, 300, 350, 400	11833	#44	11830	#55
		150, 250	84853	#47	39658	#56
8001–9000 (2441–2745)	US	200	16590	#46	39658	#56
		100	11833	#44	11830	#55
		125, 175, 225, 300, 350, 400	38678	#45	11830	#55
9001–10,000 (2746–3045)	US	150, 250	40414	#48	39658	#56
		200	84853	#47	39658	#56
		100	38678	#45	11830	#55
	US	125, 175, 225, 300, 350, 400	16590	#46	11830	#55
		150, 250	40414	#48	39658	#56
		200	84853	#47	39658	#56

3. Unthread existing gas orifices from gas manifold.

⚠ DANGER ⚠

- Do not use Teflon tape or pipe joint compound on the orifice threads. The hole in the orifice may become blocked and may cause fire, explosion, property damage, carbon monoxide poisoning, personal injury, or death.
- Use only using factory-supplied orifices. Do not attempt to drill out orifices in the field. Improperly drilled orifices may cause fire, explosion, carbon monoxide poisoning, personal injury, or death.

4. Thread replacement gas orifices into gas manifold. To prevent cross-threading, hand-tighten orifices into gas manifold until snug and then tighten one-half to one turn using wrench.

⚠ DANGER ⚠

DO NOT use an open flame to check for gas leaks.

5. Check all connections for gas leaks using commercial leak-detecting fluid or rich soap and water solution. Leaks are indicated by presence of bubbles. If leak is detected, tighten connection. If leak cannot be stopped by tightening connection, replace part(s).

Conversion to LP (Propane)

⚠ DANGER ⚠

Conversion to LP (propane) gas must be performed by qualified service personnel using a factory-supplied conversion kit. Failure to use the proper conversion kit can cause fire, explosion, property damage, carbon monoxide poisoning, personal injury, or death.

If LP (propane) conversion is required, convert the unit in accordance with form **OPT-GC** listed in **Table 1**. When conversion is complete, verify that the input rate is correct.

Burner Air Shutter Adjustment

⚠ DANGER ⚠

Failure to adjust air shutters according to directions could cause property damage, personal injury, and/or death.

- Air shutters are required on propane gas units but are optional on natural gas units. A slotted burner air adjustment screw on the end manifold bracket (see **Figure 32**) moves the air shutters and adjusts all burners simultaneously. Turn the adjustment screw clockwise to open the air shutter or counterclockwise to close the air shutter.
- After the furnace has been in operation for 15 minutes, close the air shutter until the flame turns yellow. Open the shutter until yellow disappears.

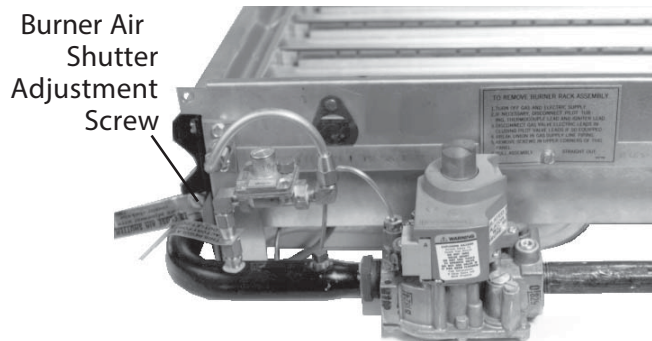

Figure 32. Burner Air Shutter Adjustment Screw

MAINTENANCE

⚠ WARNING ⚠

If you turn OFF the power supply, turn OFF the gas.

NOTE: Use only factory-authorized replacement parts.

This unit will operate with a minimum of maintenance. To ensure long life and satisfactory performance, a furnace that is operating under normal conditions should be inspected every 4 months. If the furnace is operating in an area where an unusual amount of dust, soot, or other impurities are present in the air, more frequent inspection is recommended.

MAINTENANCE—CONTINUED

Service Checklist

The following section is designed to aid a qualified service person in maintaining and servicing this equipment. At a minimum, perform the following annually:

- Check gas valve to ensure that gas flow is being shut off completely
- Clean heat exchanger both internally and externally
- Check pilot burner and main burners for scale, dust, or lint accumulation and clean as needed
- Check vent/combustion air system, inspect all joints, and replace any parts that do not appear sound
- Check main burner ports, carryover assemblies, and orifices for cleanliness
- Check wiring for any damaged wire—replace damaged wiring (refer to [Electrical Connections](#) section for wiring requirements)

Maintenance Procedures

Combination Gas Valve Maintenance

⚠ WARNING ⚠

The combination gas valve is the prime safety shutoff. To ensure positive closure, all gas supply lines must be free of dirt or scale before connecting them to the unit.

Remove external dirt accumulation and check wiring connections. The combination gas valve must be checked annually as follows to ensure that the valve is completely shutting off gas flow.

1. Locate 1/8-inch FPT INLET pressure tap on combination gas valve (see [Figure 33](#)).

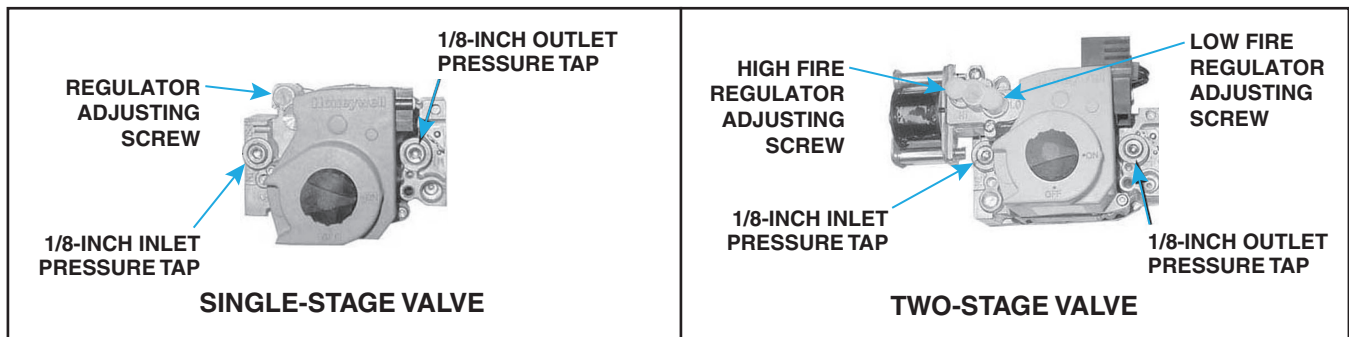

Figure 33. Combination Gas Valve Test Connections

NOTE: A manometer (fluid-filled gauge) with an inches water column scale is recommended.

2. With field-installed manual valve closed to prevent flow to gas valve, connect manometer to 1/8-inch FPT INLET pressure tap (see [Figure 33](#)).
3. With field-installed manual valve closed, turn up [thermostat](#) to fire unit and to allow unit to go through one trial for ignition.

4. Reset [thermostat](#) to shut OFF unit and observe manometer for 2 to 3 minutes for indication of gas pressure. No pressure should be indicated on manometer. If manometer indicates gas pressure, field-installed manual gas valve must be replaced or repaired before combination gas valve can be checked.
5. If manometer does not indicate gas pressure, slowly open field-installed manual gas valve. After manometer indicates that gas pressure has reached equilibrium, close manual shutoff valve.

NOTE: Refer to [Gas Supply Pressure](#) section for operational pressure settings and instructions for checking pressure settings.

6. Observe gas pressure on manometer. There should be no loss of gas pressure. If manometer indicates loss of gas pressure, replace combination gas valve before placing heater in operation.

Vent/Combustion Air System Maintenance

Check vent/combustion air system at least once a year. Inspect all joints, seams, and terminal caps. Clean grills and screens. Replace any defective parts.

Burner Rack Maintenance

Remove, disassemble, clean, reassemble, and re-install burner rack as follows:

1. Remove burner rack:
 - a. Turn OFF gas and electric supply.
 - b. Remove control access side panel.
 - c. Disconnect any pilot lines and flame sensor leads.
 - d. Mark and disconnect electric valve leads.
 - e. Uncouple union in gas supply.
 - f. Remove sheet metal screws in top corners of burner rack assembly.
 - g. Pull drawer-type burner rack out of furnace.
2. Disassemble burner rack:

NOTE: Natural gas burner racks manufactured *before* Series 6 may have a lighter tube carryover system. Break the lighter tube connection at the orifice and remove the supply tubing, the drip shield, and the lighter tube.

- a. For natural gas burner rack, remove flash carryover system from manifold end of burner rack.
 - b. For propane gas burner rack:
 - (1) Break lighter tube connection at regulator and remove lighter tube orifice supply tubing.
 - (2) Remove retaining screws in drip shield and remove shield.
 - (3) Remove retaining screws and slide out lighter tube.
 - c. Pull main burners horizontally away from injection opening and lift out.
 - d. Remove manifold bracket screws and remove manifold.
 - e. Remove burner orifices.
 - f. Remove screws and lift out pilot burner.
3. Clean burner rack in accordance with instructions in [Cleaning Pilot and Burners](#) section.
 4. Re-assemble and re-install burner rack by reversing above steps, being careful not to create any unsafe conditions.

MAINTENANCE—CONTINUED

Maintenance Procedures—Continued

Cleaning Pilot and Burners

⚠ WARNING ⚠

To prevent injury when cleaning pilot and burners, wearing eye protection is recommended.

⚠ CAUTION ⚠

To prevent damage to pilot orifice, do not ream the orifice.

If the pilot flame appears short and/or yellow, check the pilot orifice for blockage caused by lint or dust accumulation:

1. Remove the pilot orifice and clean it using compressed air.
2. Check and clean the aeration slot in the pilot burner.
3. Clean the metal sensing probe and the pilot hood with an emery cloth and wipe off the ceramic insulator.
4. Check the spark gap (see [Figure 34](#)), which should be maintained to 0.100 inch (2.5 mm).

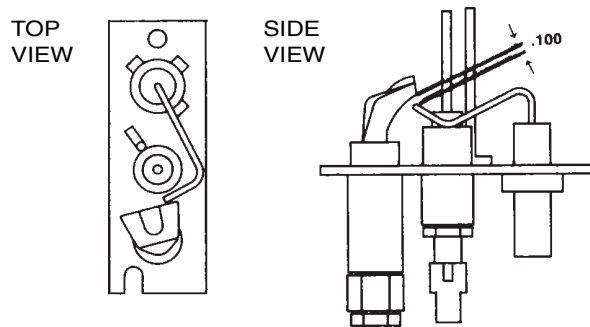

Figure 34. Pilot Assembly Spark Gap

5. After the pilot is cleaned, blow away any dirt using compressed air.
6. Clean the main burners and burner orifices using compressed air.

⚠ CAUTION ⚠

When cleaning burner ports, do not use anything that might change the port size.

7. Use an air nozzle to blow out scale and dust accumulation from the burner ports. Alternate blowing compressed air through the burner ports and then through the venturi. Use a fine wire to dislodge any stubborn particles from the burner ports.
8. Clean the burner rack carryover systems using compressed air.

⚠ WARNING ⚠

Due to high voltage on pilot spark wire and pilot electrode, do not touch when energized.

NOTE: When checking for spark with the pilot burner assembly removed from the burner rack, the pilot assembly must be grounded to the heater for proper spark.

1. If no spark occurs, check the following:
 - a. Using microammeter, measure voltage between terminals TH and 7 on ignition controller. Voltage should be at least 20V and no higher than 32V. Refer to **TROUBLESHOOTING** section if no voltage is observed.
 - b. Check for short to ground in high tension lead and/or ceramic insulator.
 - c. Verify that pilot spark gap (see **Figure 34**) is approximately 0.100 inch (2.5 mm).
 - d. If the above conditions are normal and no spark occurs, replace the ignition controller.

NOTE: If replacing an earlier model of ignition controller (see **Figure 35), order a replacement kit (PN **257472** for a unit with recycling gas control option AH2 or PN **257473** for a unit with gas control with lockout option AH3). Option codes are listed on the unit wiring diagram.**



RECYCLING IGNITION CONTROLLER FOR GAS CONTROL OPTION AH2, UTEC MODEL 1003-638A (PN **257009**): REPLACE WITH REPLACEMENT KIT (PN **257472**)



IGNITION CONTROLLER WITH LOCKOUT FOR GAS CONTROL OPTION AH3, UTEC MODEL 1003-514 (PN **257010**): REPLACE WITH REPLACEMENT KIT (PN **257473**)

Figure 35. Obsolete Ignition Controllers

2. If the main gas valve fails to open with a normal full-size pilot flame established, check the following:
 - a. If voltage between black and brown leads on main gas valve is 20–32 VAC and there is no main gas flow with built-in manual valve in FULL OPEN position, main valve is defective.
 - b. If there is no voltage between black and brown leads on main gas valve, check for disconnected or shorted flame sensor lead or flame sensor probe.
3. If the above conditions are normal and main gas flow is still off, the ignition controller is probably defective. Do not attempt to service the ignition controller as it does not contain any replaceable components.

MAINTENANCE—CONTINUED

Maintenance Procedures—Continued

Cleaning Heat Exchanger

1. Clean outer surfaces (circulating air side):
 - a. Remove inspection panels in ductwork or remove ductwork.
 - b. Remove baffles between heat exchanger tubes. If heater has been converted for high CFM (look for conversion label), these baffles will have already been removed.
 - (1) Remove A screws (see [Figure 2](#)).
 - (2) Slide each baffle forward.
 - c. Use brush and/or air hose to remove accumulated dust and grease deposits from heat exchanger tubes and baffles.
 - d. Re-install baffles:
 - (1) Slide baffles into slot in other end of heat exchanger.
 - (2) Replace A screws (see [Figure 2](#)).
 - e. Secure ductwork as necessary.
2. Clean inner surfaces (combustion gas side):
 - a. Remove burner rack assembly in accordance with [Burner Rack Maintenance](#) section to allow access to inside of heat exchanger tubes.
 - b. Use mirror and flashlight to examine narrow section of each tube.
 - c. Use 1/2-inch diameter furnace brush to scrub tube walls.
 - d. Use brush and/or air hose (18-to 24-inch) to remove any accumulated dust, rust, and/or soot.
 - e. Re-assemble furnace and check for proper operation.

Venter Motor Maintenance

Power venter motors are permanently lubricated. No oiling is required.

TROUBLESHOOTING

NOTE: If the furnace is equipped with electronic modulation option AG39 or AG40, see [Figure 30](#) for additional troubleshooting guidelines.

Refer to [Table 25](#) to troubleshoot the unit.

Table 25. General Troubleshooting

Symptom	Probable Cause	Remedy
A. Venter motor will not start	1. No power to furnace	Turn ON power and check supply fuses or circuit breaker
	2. No 24V power to venter relay	Turn up thermostat and check control transformer output Check for loose or improper wire connections
	3. Defective venter relay	Replace defective part
	4. Defective motor or capacitor	Replace defective part
B. Pilot will not light with venter operating	1. Manual valve not open	Open manual valve
	2. Air in gas line	Bleed gas line
	3. Dirt in pilot orifice	Remove pilot orifice and clean with compressed air or solvent
	4. Gas pressure too high or too low	Adjust gas pressure (refer to Measure and Adjust Manifold (Outlet) Gas Pressure section)
	5. Kinked pilot tubing	Replace tubing
	6. Pilot valve does not open	If 24V power is available at valve, replace valve
	7. No spark	
	a. Loose wire connections	Ensure that all wires connections are solid
	b. Transformer failure	Ensure that 24V power is available
	c. Incorrect spark gap	Maintain spark gap at 0.100 inch
	d. Spark cable shorted to ground	Replace worn or grounded spark cable
	e. Spark electrode shorted to ground	Replace pilot if ceramic spark electrode is cracked or grounded
	f. Drafts affecting pilot	Ensure that all panels are in place and are tightly secured to prevent drafts at pilot
	g. Ignition control not grounded	Ensure that ignition control is grounded to furnace chassis
	h. Faulty ignition controller	If 24V power is available to ignition controller and all other causes have been eliminated, replace ignition control
	8. Optional lockout device interrupting control circuit due to above causes	Reset lockout by interrupting control at thermostat
9. Faulty combustion air proving switch	Replace combustion air proving switch	
C. Pilot lights but main valve will not open	1. Manual valve not open	Open manual valve
	2. Main valve not operating	
	a. Defective valve	If 24V power is available at valve connections and valve remains closed, replace valve
	b. Loose wire connections	Check and tighten all wiring connections
	3. Ignition control does not power main valve	
	a. Loose wire connections	Check and tighten all wiring connections
	b. Flame sensor grounded, pilot lights, and spark continues	Ensure that flame sensor lead is not grounded and that insulation or ceramic is not cracked; replace as required
	c. Incorrect gas pressure	Adjust gas pressure (refer to Measure and Adjust Manifold (Outlet) Gas Pressure section)
	d. Cracked ceramic at sensor	Replace sensor
	e. Faulty ignition controller	If all checks listed in Spark Ignition System Maintenance section indicate no other cause, replace ignition controller (do not attempt to repair ignition controller, which has no field-replaceable parts)
D. Insufficient heat with heater operating	1. Dirty filters in field-supplied blower system	Clean or replace filters
	2. Incorrect manifold pressure	Check manifold pressure (refer to Measure and Adjust Manifold (Outlet) Gas Pressure section)
	3. Limit control cycling on	Check air throughput
	4. Improper thermostat location or adjustment	Refer to thermostat manufacturer's instructions
	5. Belt slipping on field-supplied blower	Adjust belt tension in accordance with manufacturer's instructions
	6. Fan control improperly wired	Ensure that wiring connections are in accordance with wiring diagram
	7. Defective fan control	Replace fan control
	8. Field-supplied blower set for too low temperature rise	Decrease blower speed or increase static pressure

INSTALLATION RECORD (TO BE COMPLETED BY INSTALLER)

Installer:

Name _____
Company _____
Address _____

Phone _____

Distributor (company from which the unit was purchased):

Company _____
Contact _____
Address _____

Phone _____

Model _____ **Serial No.** _____ **Date of Installation** _____

Specific installation notes (i.e., location, amps, gas pressure, temperature, voltage, adjustments, warranty, etc.):

BUILDING OWNER OR MAINTENANCE PERSONNEL:

For service or repair:

Contact the Installer listed above.

If you need additional assistance, contact the Distributor listed above.

For more information, contact your Factory Representative.

