

SEPARATED-COMBUSTION PACKAGED FURNACE/BLOWER INSTALLATION, OPERATION, AND MAINTENANCE

MODEL SCE



⚠ DANGER ⚠

FIRE OR EXPLOSION HAZARD

- Failure to follow safety warnings exactly could result in serious injury, death, or property damage.
- Improper installation, adjustment, alteration, service, or maintenance can cause serious injury, death, or property damage.
- Installation and service must be performed by a qualified installer, service agency, or the gas supplier.
- Be sure to read and understand the installation, operation, and service instructions in this manual.
- Do not store or use gasoline or other flammable vapors and liquids in the vicinity of this or any other appliance.

WHAT TO DO IF YOU SMELL GAS

- Do not try to light any appliance.
- Do not touch any electrical switch; do not use any phone in your building.
- Leave the building immediately.
- Immediately call your gas supplier from a phone remote from the building. Follow the gas supplier's instructions.
- If you cannot reach your gas supplier, call the fire department.

DO NOT DESTROY. PLEASE READ CAREFULLY. KEEP IN A SAFE PLACE FOR FUTURE REFERENCE.

TABLE OF CONTENTS

GENERAL INFORMATION	3
References	4
Important Safety Information	4
Separated Combustion	5
Installation Codes	5
Special Installations (Aircraft Hangars/Garages)	5
Warranty	5
Dimensions	6
Weights	7
Clearances	7
Location	7
Hazards of Chlorine	7
INSTALLATION	8
Uncrating/Unpacking	8
Shipped-Separate Parts	8
Suspension	9
Mounting	9
Duct Connections	10
Requirements and Suggestions for Connecting and Installing Ducts	11
Venting/Combustion Air Connections	12
Specific Venting Requirements: Piping	12
Specific Venting Requirements: Venter Outlet and Combustion Air Inlet Connections	13
Specific Venting Requirements: Joints and Sealing	13
Specific Venting Requirements: Support	14
Specific Venting Requirements: Clearance	15
Specific Venting Requirements: Concentric Adapter Box	15
Specific Venting Requirements: Concentric Adapter Box Pipe Connections	15
Vent Terminal Options	16
Vertical Vent Terminal (Option CC2) Installation	17
Horizontal Vent Terminal (Option CC6) Installation	22
Piping Connections	26
Gas Supply Pressure	26
Gas Supply Piping	27
Supply Piping Connections	27
Condensate Drain Installation	28
Electrical Connections	29
Control Wiring	29
CONTROLS	30
Thermostat	30
Combustion Air Proving Switch	30
Blower Fan Control	31
Limit Control	31
Variable Frequency Drive	31
Combination Gas Valve	31
Optional Two-Stage Control (Heating Only Application)	32
Optional Two-Stage Control (Makeup Air Application)	32
Optional Ductstat with Capillary Tubing (Option AG3)	32
Optional Ductstat with Electronic Remote Setpoint Module (Option AG15 or AG16)	33
Optional Electronic Modulation	33
Electronic Modulation Between 50% and 100% Firing Rate (Option AG7, AG8, or AG9)	33
Computer-Controlled Electronic Modulation Between 50% and 100% Firing Rate (Option AG21)	34
Electronic Modulation Between 20–28% and 100% Firing Rate (Option AG39)	34
Electronic Modulation Between 20–28% and 100% Firing Rate (Option AG40)	35

TABLE OF CONTENTS—CONTINUED

Pilot and Ignition Systems	37
Burners, Burner Orifices, and Carryover System	37
Dampers and Damper Controls	38
Dirty Filter Switch	39
OPERATION	39
Pre-Startup Checklist	39
Startup	40
Post-Startup Checklist	40
ADJUSTMENTS.	41
Belts, Blowers, and Drives	41
Checking and Adjusting Belt Tension	41
Adjusting Blower Speed	41
Reversing Blower Rotation	42
Motor Load and Amp Adjustment	42
Measure and Adjust Manifold (Outlet) Gas Pressure	43
High Elevation (>2,000 Feet/609 Meters) Installations	44
Conversion to LP (Propane)	45
Burner Air Shutter Adjustment	46
Damper Linkage Adjustment.	46
Dirty Filter Switch Adjustment.	47
MAINTENANCE.	48
Service Checklist	48
Maintenance Procedures	48
Combination Gas Valve Maintenance	48
Vent/Combustion Air System Maintenance.	49
Burner Rack Maintenance.	49
Cleaning Pilot and Burners	50
Spark Ignition System Maintenance	51
Cleaning Heat Exchanger	52
Venter Motor Maintenance	52
Air Circulation System Maintenance	52
TROUBLESHOOTING	52
INSTALLATION RECORD (TO BE COMPLETED BY INSTALLER).	56

GENERAL INFORMATION

- This unit has been tested for capacity and efficiency so as to provide many years of safe and dependable comfort providing it is properly installed and maintained. With regular maintenance, this unit will operate satisfactorily year after year. Abuse, improper use, and/or improper maintenance can shorten the life of the appliance and create unsafe hazards.
- To achieve optimum performance and minimize equipment failure, it is recommended that periodic maintenance be performed on this unit. The ability to properly perform maintenance on this equipment requires certain tools and mechanical skills.
- This unit has been design-certified by the Canadian Standards Association to ANSI Standards and is available for use with either natural or propane gas. The type of gas, the rate, and the electrical characteristics are on the unit rating plate.

GENERAL INFORMATION—CONTINUED

References

Type	Form*	PN
Replacement parts	SC-SCE-SSCBL-SSCDBL-RPL	269822
Vent/combustion air kit installation	OPT-CC2-CC6	205892
Maxitrol amplifier replacement kit installation	OPT-AG7,8,9,9H	262319
Ignition controller replacement kit installation	OPT-IGN-CNTRL	134704
Gas conversion	OPT-GC	143147

*Also available at www.reznorhvac.com.

Important Safety Information

Please read all information in this manual thoroughly and become familiar with the capabilities and use of your appliance before attempting to operate or maintain this unit. Pay attention to all dangers, warnings, cautions, and notes highlighted in this manual. Safety markings should not be ignored and are used frequently throughout to designate a degree or level of seriousness.

DANGER: A danger statement describes a potentially hazardous situation that if not avoided, will result in severe personal injury or death and/or property damage.

WARNING: A warning statement describes a potentially hazardous situation that if not avoided, can result in severe personal injury and/or property damage.

CAUTION: A caution statement describes a potentially hazardous situation that if not avoided, can result in minor or moderate personal injury and/or property damage.

NOTE: A note provides important information that should not be ignored.

DANGER

Gas-fired appliances are not designed for use in hazardous atmospheres containing flammable vapors or combustible dust, in atmospheres containing chlorinated or halogenated hydrocarbons, or in applications with airborne silicone substances.

WARNING

For your safety, read the warning labels on the unit.

NOTES:

- Installation should be done by a qualified agency in accordance with the instructions in this manual and in compliance with all codes and requirements of authorities having jurisdiction.
- The instructions in this manual apply only to the model SCE blower-type unit heater with blower cabinet.
- Model SCE units are not certified for residential use.

Separated Combustion

- This separated-combustion unit is designed and manufactured in accordance with the ANSI definition of separated combustion, which reads, “Separated Combustion System Appliance: A system consisting of an appliance and a vent cap(s) supplied by the manufacturer, and (1) combustion air connections between the appliance and the outside atmosphere, and (2) flue gas connections between the appliance and vent cap, of a type(s) specified by the manufacturer but supplied by the installer, constructed so that, when installed in accordance with the manufacturer’s instructions, air for combustion is obtained from the outside atmosphere and flue gases are discharged to the outside atmosphere.”
- Separated-combustion units are designed to separate air for combustion and flue products from the environment of the building in which the unit is installed. Separated-combustion appliances are recommended for use in dust-laden and some corrosive-fume environments or in buildings with negative pressure (up to 0.15 IN WC). As the definition states, all separated-combustion, power-vented equipment must be equipped with both combustion-air and exhaust piping to the outdoors.

Installation Codes

- These units must be installed in accordance with local building codes. In the absence of local codes, in the United States, the unit must be installed in accordance with the *National Fuel Gas Code* NFPA/ANSI Z223.1 (latest edition). A Canadian installation must be in accordance with the *CSA B149.1 Natural Gas and Propane Installation Code*. These codes are available from CSA Information Services, 1-800-463-6727. Local authorities having jurisdiction should be consulted before installation is made to verify local codes and installation procedure requirements.
- These gas-fired products are certified by ANSI Z83 family of standards governing the safe usage of heating equipment in the industrial/commercial marketplace. This includes using the heaters in makeup air applications to supply corridor pressurization in commercial buildings such as office structures and apartment complexes.
- The heaters are not certified as residential heating equipment and should not be used as such.
- Clearances from the heater and vent to combustible construction or material in storage must conform with the *National Fuel Gas Code* ANSI Z223.1 (latest edition) pertaining to gas-burning devices, and such material must not attain a temperature over 160°F (71°C) by continued operation of the heater.

Special Installations (Aircraft Hangars/Garages)

Installations in aircraft hangars should be in accordance with NFPA No. 409 (latest edition), *Standard for Aircraft Hangars*; in public garages in accordance with NFPA No. 88A (latest edition), *Standard for Parking Structures*; and for repair garages in accordance with NFPA No. 88B (latest edition), *Standard for Repair Garages*. In Canada, installations in aircraft hangars, repair garages, and parking garages should be in accordance with the requirements of the enforcing authorities and in accordance with CSA B149 codes.

Warranty

Refer to the limited warranty information on the warranty card in the owner’s envelope. Warranty is void if:

- a. Separated-combustion heaters are used in atmospheres containing flammable vapors or atmospheres containing chlorinated or halogenated hydrocarbons or any contaminant (silicone, aluminum oxide, etc.) that adheres to the spark ignition flame sensing probe.
- b. Wiring is not in accordance with the diagram furnished with the heater.
- c. Unit is installed without proper clearance to combustible materials.

GENERAL INFORMATION—CONTINUED

Dimensions

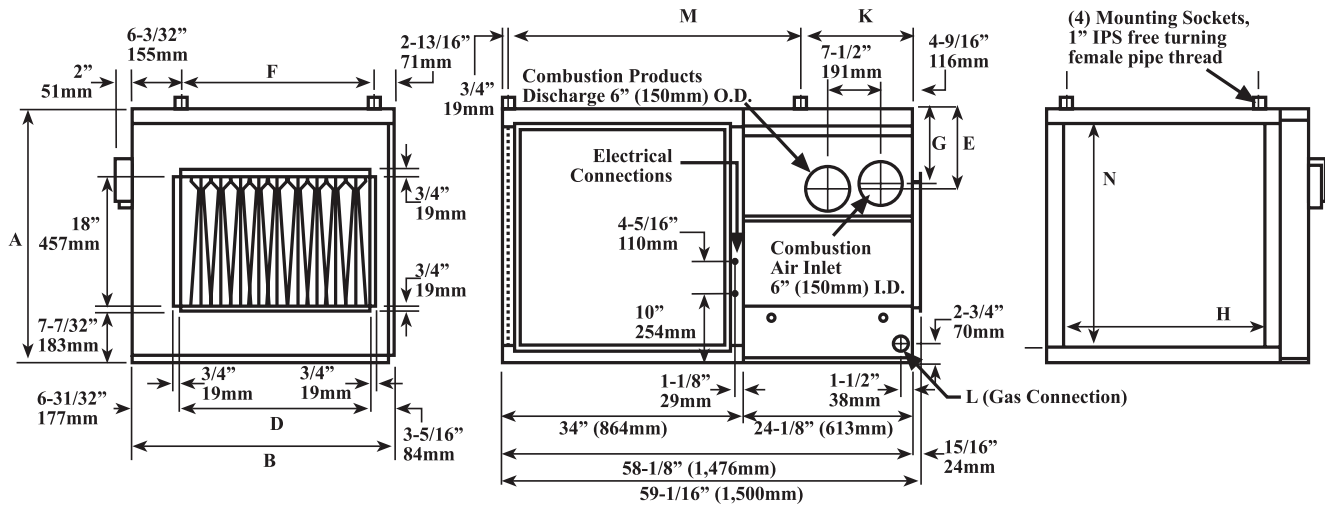

STANDARD MODEL SCE

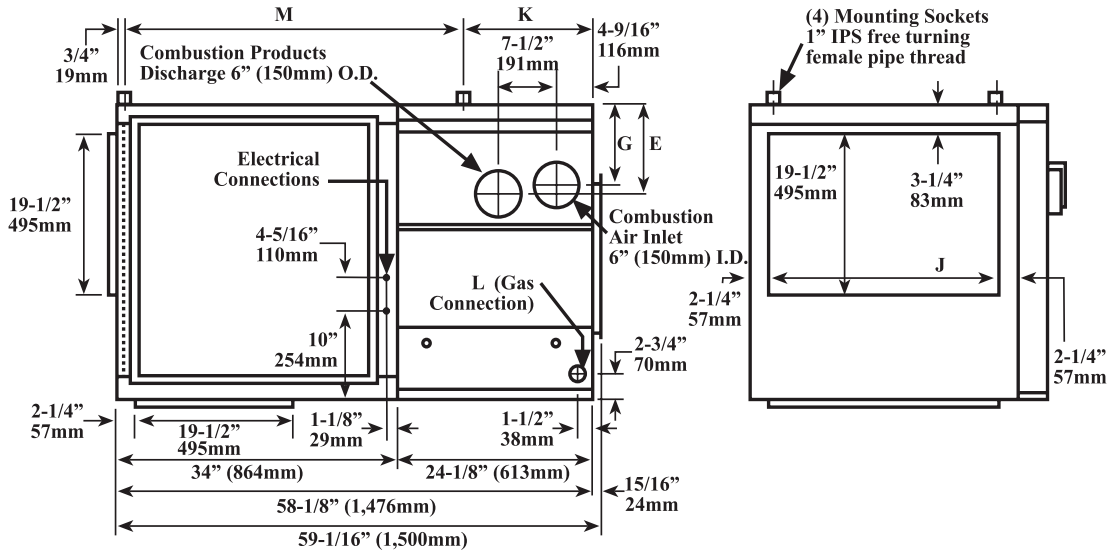

MODEL SCE WITH OPTIONAL HORIZONTAL INLET WITH DUCT FLANGES

Figure 1. Model SCE Dimensions

Table 2. Dimensions							
Dimension (See Figure 1)	Unit Size						
	125	150, 175	200, 225	250	300	350	400
	Inches ±1/8 (mm ±3)						
A	32-1/4 (819)			35-1/4 (895)			
B	25-1/4 (641)	30-3/4 (781)	36-1/4 (921)	43-1/2 (1105)	44-1/2 (1130)	50 (1270)	55-1/2 (1410)
D	15-1/4 (387)	20-3/4 (527)	26-1/4 (667)	33-1/2 (851)	34-1/2 (876)	40 (1016)	45-1/2 (1156)
E	8-1/8 (206)		10-3/4 (273)	9-3/4 (248)	10-3/4 (273)		
F	16-1/4 (413)	21-3/4 (552)	27-1/4 (692)	34-1/2 (876)	35-1/2 (902)	41 (1041)	46-1/2 (1181)
G	7 (178)		10 (254)	9 (229)	10 (254)		
H	17-3/4 (451)	23-1/4 (591)	28-3/4 (730)	36 (914)	37 (940)	42-1/2 (1080)	48 (1219)
J	17-3/8 (441)	22-7/8 (581)	28-3/8 (721)	35-5/8 (905)	38-5/8 (930)	42-1/8 (1070)	47-5/8 (1210)
K	17 (432)	18-3/8 (467)	17 (432)	16 (406)	17 (432)	18-3/8 (467)	17 (432)
L	1/2 (13)			3/4 (19)			
M	40-1/4 (1022)	39 (991)	40-1/4 (1022)	39-1/4 (997)	40-1/4 (1022)	39 (991)	40-1/4 (1022)
N	27-3/4 (705)			30-3/4 (781)			

Weights

Before installation, check the supporting structure to ensure that it has sufficient load-carrying capacity to support the weight of the unit. Refer to **Table 3**, which lists unit weight based on unit size.

Table 3. Weights					
Unit Size					
125	150, 175	200, 225	250, 300	350	400
Net Weight (Pounds (kg))					
313 (142)	358 (162)	382 (173)	482 (219)	498 (226)	560 (254)

Clearances

Clearance to combustibles is defined as the minimum distance—from the heater to a surface or object—that is necessary to ensure that a surface temperature of 90°F (50°C) above the surrounding ambient temperature is not exceeded. For safety and convenience, ensure that the clearances listed in **Table 4** are provided. Minimum clearances are also listed on the heater rating plate.

Table 4. Clearances	
Unit Surface	Minimum Clearances (Inches (mm))
Top	6 (152)
Control side	6 (152) + width of unit
Side opposite controls	6 (152)
Bottom, to combustibles	6 (152)
Bottom, to noncombustibles	0 (0)

Location

⚠ CAUTION ⚠

Do not locate the unit where it may be exposed to water spray, rain, or dripping water.

- For best results, the heater should be placed with certain rules in mind. In general, a unit should be located from 8–12 feet (2.6–3.6 meters) above the floor. Units should always be arranged to blow toward or along exposed wall surfaces, if possible. Where two or more units are installed in the same room, a general scheme of air circulation should be maintained.
- Suspended heaters are most effective when located as close to the working zone as possible, and this fact should be kept in mind when determining the mounting heights to be used. However, avoid directing the discharged air directly on the room occupants.
- Partitions, columns, counters, or other obstructions should be taken into consideration when locating the unit heater, so that a minimum quantity of airflow will be deflected by such obstacles. When units are located in the center of the space to be heated, the air should be discharged toward the exposed walls. In large areas, units should be located to discharge air along exposed walls with extra units provided to discharge air in toward the center of the area.
- At those points where infiltration of cold air is excessive, such as at entrance doors and shipping doors, it is desirable to locate the unit so that it will discharge directly toward the source of cold air from a distance of 15–20 feet (4.5–6 meters).

Hazards of Chlorine

⚠ WARNING ⚠

SC series separated-combustion units are not designed or approved for use in atmospheres containing flammable vapors or atmospheres highly-laden with chlorinated vapors.

GENERAL INFORMATION—CONTINUED

Hazards of Chlorine—Continued

NOTE: Remember, chlorine is heavier than air. This fact should be kept in mind when determining the installation location of heaters and building exhaust systems.

The presence of chlorine vapors in the combustion air of heating equipment presents a potential corrosion hazard. Chlorine, found usually in the form of Freon or degreaser vapors, when exposed to flame will precipitate from the compound and form a solution with any condensation present in the heat exchanger or associated parts. The result is hydrochloric acid, which readily attacks all metals, including 300 grade stainless steel. Care should be taken to separate these vapors from the combustion process. This may be done by wise location of the unit with regard to exhausters or prevailing wind directions.

INSTALLATION

NOTE: Before installation, make preparations for necessary supplies, tools, and manpower.

Uncrating/Unpacking

- The furnace is shipped completely-assembled. Immediately upon uncrating, check the gas specifications and electrical characteristics on the unit's rating plate to be sure that they agree with the gas and electric supply at the installation site.
- Check the unit for any damage that may have been incurred during shipment. If damage is found, document the damage with the transporting agency and immediately contact your Distributor. If you are an authorized Distributor, follow the FOB freight policy procedures.

NOTE: After removing the shipping clips that fasten the unit to the crate, it is required that the bolts that attach the shipping clips be reinstalled for support.

- The bottom corners are fastened to the crate using angled shipping clips. Remove the bolts from the shipping clips and remove the clips. Reinstall the bolts on the heater legs to support the corner leg and the heater bottom.
- To protect the unit during shipping, blower models have special supports that must be removed before installation. Remove the special supports as follows:
- **Blower support legs:** Remove the blower support legs and screws.
- **Motor shipping block:** Remove the wooden block located under the motor bracket. Find the two rubber pads shipped in the instruction envelope. Place these pads on the ends of the motor bracket bolts.
- **Motor shipping plate:** Units equipped with motors of 1-1/2 HP or less have a metal shipping plate attached between the motor and the blower housing. The shipping plate must be removed and the plate and screws discarded. On a unit factory-equipped with an optional belt guard, the belt guard must be removed to reach the shipping plate.
- **Concentric adapter box:** The concentric adapter box assembly in the venting/combustion air kit (option CC2 or CC6) is required on all separated-combustion models. Ensure that the concentric adapter box carton is at the installation site (refer to parts list in [Table 8](#) or [Table 10](#)).

Shipped-Separate Parts

Some gas control options have parts that are either shipped loose—with the heater—or shipped separate. Before beginning installation, ensure that any shipped-separate parts ordered are available at the site. Shipped-separate options could include a shutoff valve, a condensate drain kit, a [thermostat](#), a remote console, a disconnect switch, or high-temperature vent sealing tape. Also, if your unit is equipped with any of the gas control options listed in [Table 5](#), ensure that these parts are available at the job site.

Table 5. Shipped-Separate Parts for Gas Control Options

Application	Option	Part(s)
Heating	AG7	Thermostat (PN 48033)
Makeup air	AG3	Control switch (PN 29054)
	AG8	Control switch (PN 29054); sensor and mixing tube (PN 48041)
	AG9	Control switch (PN 29054); remote temperature selector (PN 48042); sensor and mixing tube (PN 48041)
	AG15, AG16	Control switch (PN 29054); remote temperature selector (PN 115848); stage adder module (PN 115849); discharge air sensor holder (PN 115850); discharge air sensor holder bracket (PN 213612); AG16 also includes temperature display (PN 115852)
	AG39	Remote temperature selector (PN 174849); temperature sensor (PN 133228); mixing tube (PN 90323)

NOTE: If an optional remote console is ordered, the control switch and temperature selector may be mounted on the console.

Suspension

⚠ WARNING ⚠

Units must be level for proper operation. Do not place additional weight on or add additional weight to the suspended unit.

The unit has four-point suspension (see hanger center line dimensions shown in [Figure 1](#)). At each suspension point, the unit is factory-equipped with a free-turning, female, 1-inch NPT pipe hanger. Suspend the unit by connecting the pipe hanger to a 1-inch threaded pipe. See [Figure 2](#) for the standard and alternative suspension methods. The factory-installed pipe hanger may be removed and the heater may be suspended as shown in the right view of [Figure 2](#).

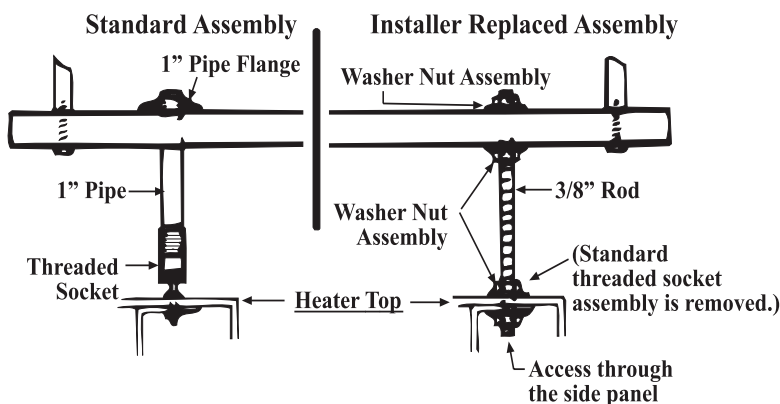

Figure 2. Suspension Methods

Mounting

NOTE: Support is required where furnace and blower cabinets meet.

- Model SCE requires six mounting support locations—three on each side—as shown in [Figure 3](#).

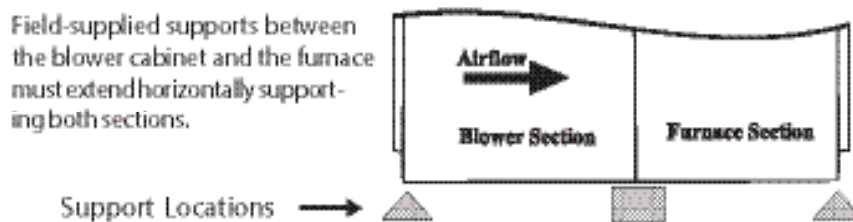

Figure 3. Support Locations

INSTALLATION—CONTINUED

Mounting—Continued

- Supports (PN 74487) available from the manufacturer or field-fabricated legs, as shown in **Figure 4**, may be used at the four corner support locations. Do not use this type of support at the center support locations between the furnace and the blower section. At the center locations, a field-fabricated angle-iron brace support must extend horizontally, jointly supporting a portion of both the furnace and the blower cabinet. All supports must be noncombustible.

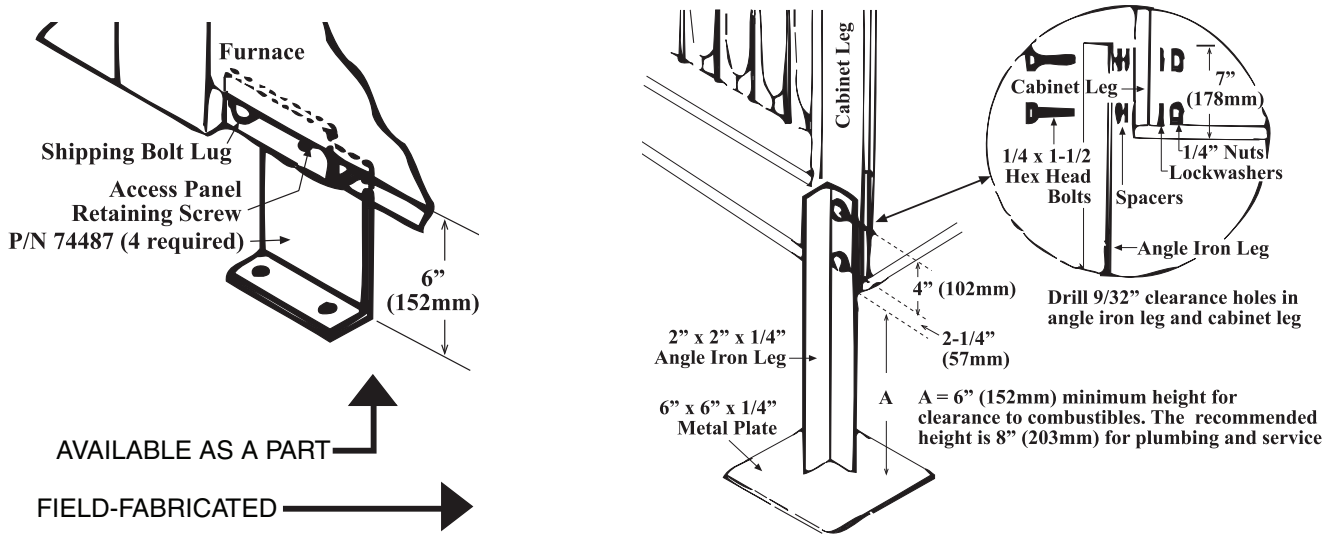

Figure 4. Corner Mounting Supports

Duct Connections

Refer to **Table 6** for duct connection dimensions.

Table 6. Duct Connection Dimensions					
Unit Size					
125	150, 175	200, 225	250, 300	350	400
Dimension G (Inches (mm))*					
15-1/4 (387)	20-3/4 (527)	26-1/4 (667)	34-1/2 (876)	40 (1016)	45-1/2 (1156)

*See **Figure 5**.

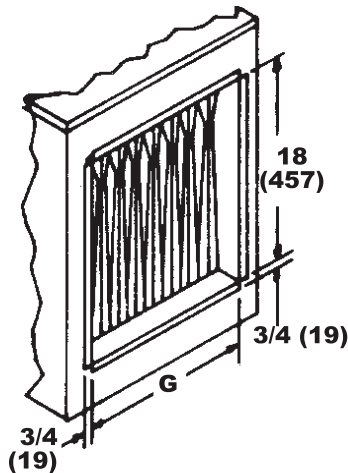

Figure 5. Duct Connection Dimensions

Requirements and Suggestions for Connecting and Installing Ducts

- **Type of ductwork:** The type of duct installation to be used depends in part on the construction type of the roof—whether wood or steel bar joist, steel truss, or pre-cast concrete—and the ceiling—whether hung, flush, etc.
- **Ductwork material:** Rectangular duct should be constructed of galvanized iron—not lighter than No. 26 US gauge—or aluminum—No. 24 B&S gauge.
- **Ductwork structure:** All duct sections 24 inches (610 mm) or wider and over 48 inches (1,219 mm) in length should be cross-broken on top and bottom and should have standing seams or angle-iron braces. Joints should be S and drive strip or locked.
- **Through masonry walls:** No warm air duct should come in contact with masonry walls. Insulate around all air duct through masonry walls with 1-inch (not less than 1/2-inch) of insulation.
- **Through unheated space:** Insulate all exposed warm air ducts passing through an unheated space with 1-inch (not less than 1/2-inch) of insulation.
- **Duct supports:** Suspend all ducts securely from adjacent buildings members. Do not support ducts from unit duct connections.
- **Duct sizing:** Proper sizing of the supply air ductwork is necessary to ensure a satisfactory heating installation. The recognized authority for duct size is the Air Conditioning Contractor's Association, 2800 Shirlington Road, Suite 300, Arlington, VA 22206 (www.acca.org). A manual covering duct sizing in detail may be purchased directly from them.

⚠ CAUTION ⚠

To prevent possible motor overloading, ensure that the external duct system static pressure is within the limits shown on the rating plate and that the motor pulley and belt are properly adjusted.

- **Horizontal discharge duct length:** To reduce losses at the furnace outlet, a minimum horizontal duct run of 24 inches (610 mm) is recommended before turns or branches are made in the duct system.

⚠ CAUTION ⚠

The joint where the supply air duct attaches to the furnace must be sealed securely to prevent air leakage into draft hood or burner rack area. Leakage can cause poor combustion and pilot problems, can shorten heat exchanger life, and can cause poor performance.

- **Supply air duct/furnace horizontal connection:** The seal between the furnace and the duct must be mechanical using U-type flanges on the top and bottom of the connecting duct to ensure tight joints and an airtight fit. Refer to [Figure 6](#) and perform the following steps:
 - a. Ensure that flanges on the furnace (heat exchanger) turn out as shown.
 - b. Shape duct connection as shown: U-type on top and bottom and L-type on sides.
 - c. Slide U-channels over furnace top and bottom flanges making connection.
 - d. Form U-channels to seal sides (see DETAIL A) and drill and lock with sheet metal screws.
- **Access panels:** Install removable access panels (see [Figure 6](#)) on both the upstream and downstream sides of the furnace. The access panels must be accessible when the furnace is in service and should be a minimum of 6 × 10 inches (152 × 254 mm) in size so smoke or reflected light may be observed inside the casing to indicate the presence of leaks in the heat exchanger. Ensure that the access panels are installed in such a manner so as to prevent leakage.
- **Return air duct/furnace connection:** All return air ducts should be attached and sealed to the return air flanges to provide airtight connections.
- **Return air duct/grill size:** Ensure that return air ducting or grills have a free area equal to the size of the return duct connection.

INSTALLATION—CONTINUED

Duct Connections—Continued

Requirements and Suggestions for Connecting and Installing Ducts—Continued

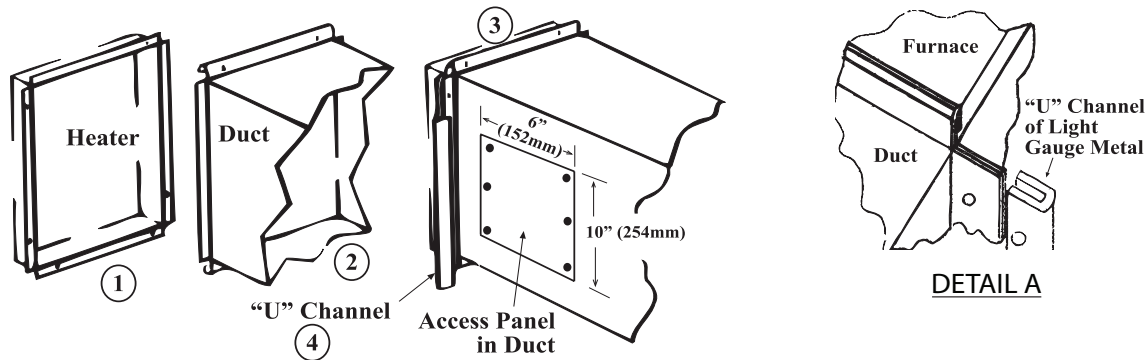

Figure 6. Connecting Ductwork to Furnace

Venting/Combustion Air Connections

⚠ WARNING ⚠

Do not use an existing venting system. This heater requires installation of the combustion air/vent system ordered with the unit (either option CC2 or CC6). Vent installation to be any listed vent system manufacturer. Do not intermix different vent system parts from different manufacturers in the same venting system.

- All separated-combustion, power-vented units **MUST BE** equipped with both combustion air and exhaust piping to the outdoors. The unique concentric adapter box designed for use with this heater allows for both combustion air and exhaust piping with only one horizontal or vertical penetration hole in the building.
- These instructions apply to installation and use of the concentric adapter and vent/combustion air kit (option CC2 or CC6) designed for use with all Reznor separated-combustion products. The systems illustrated in this manual are the only venting/combustion air systems approved for these separated-combustion units. Do not use this concentric adapter box with any other products.
- Installation should be done by a qualified agency in accordance with these instructions. The service agency installing this separated-combustion system is responsible for the installation.

Specific Venting Requirements: Piping

All pipe is field-supplied. Requirements for both the vent pipe and the combustion air inlet pipe are as follows:

- **Vent pipe:** Vent pipe approved for a Category III appliance OR single-wall, 26-gauge or heavier galvanized (or a material of equivalent durability and corrosion resistance) vent pipe is required between the heater and the concentric adapter box. Double-wall (Type B) vent pipe is required for the vent terminal section. The length of vent pipe that extends through the box and runs concentric through the combustion air pipe must be one piece with no joints.
- **Combustion air pipe:** Sealed, single-wall galvanized pipe is recommended for combustion air.
- **Pipe length and diameter:** Vent pipe diameters and maximum indoor vent lengths apply to both horizontal and vertical vents. Pipe diameter and length requirements listed for the indoor sections of pipe—between the heater and the concentric adapter box—are listed in [Table 7](#).

NOTE: Add all straight sections and equivalent lengths for elbows. The total length of the straight sections and elbows must not exceed the maximum length.

- **Outdoor concentric pipes length and diameter:** The lengths of the outside (terminal) concentric pipes depend on the installation. The diameters are 8 inches (203 mm) for the inlet air pipe and 5 inches (127 mm) for the vent pipe.

Diameter/Length	Unit Size	
	125–175	200–400
Diameters (Inches (mm))		
Vent pipe	6 (152)	
	—	7 (178)
Inlet air pipe	6 (152)	
	—	7 (178)
Lengths (Feet (Meters))		
Minimum	5 (1.5)	
Maximum, 6-inch pipe	50 (15)	
Maximum, 7-inch pipe	—	70 (21)
Equivalent straight length for 45-degree elbow	4 (1.2)	
Equivalent straight length for 90-degree elbow	8 (2.4)	

Specific Venting Requirements: Venter Outlet and Combustion Air Inlet Connections



All separated-combustion units MUST BE equipped with both combustion air and exhaust piping to the outdoors.

Model SCE heaters have both an inlet air and a venter outlet connection. Both are 6 inches (152 mm) in diameter for all unit sizes.

NOTE: If using 7-inch pipe on unit sizes 200–400, use a tapered 6- to 7-inch enlarger to attach the vent pipe and a 7- to 6-inch reducer to attach the combustion air pipe.

Specific Venting Requirements: Joints and Sealing

Seal pipe joints as follows:

- **To seal joints in Category III vent pipe:** Follow the pipe manufacturer’s instructions for joining and sealing Category III vent pipe sections.
- **To seal joints in single-wall vent or combustion air pipe:** Secure slip-fit pipe connections using sheet metal screws or rivets. Seal all joints with aluminum tape or silicone sealant.
- **To seal the joint in the terminal section of double-wall vent pipe (allowed ONLY ABOVE the concentric pipes on a VERTICAL vent):** Follow the pipe manufacturer’s instructions for joining and sealing double-wall vent pipe sections.
- **To seal the joint between the terminal section of double-wall vent pipe and the vent cap:** Follow the illustrated step-by-step instructions in [Figure 7](#).
- **To seal the joint between the terminal section of double-wall vent pipe and a single-wall or Category III vent pipe:** follow the illustrated step-by-step instructions in [Figure 8](#). Make this connection no more than 6 inches (152 mm) from the concentric adapter box.

NOTE: Pipes and vent caps may not look exactly as shown in the illustrations. Instructions apply to both horizontal and vertical vent kits.

INSTALLATION—CONTINUED

Venting/Combustion Air Connections—Continued

Specific Venting Requirements: Joints and Sealing—Continued

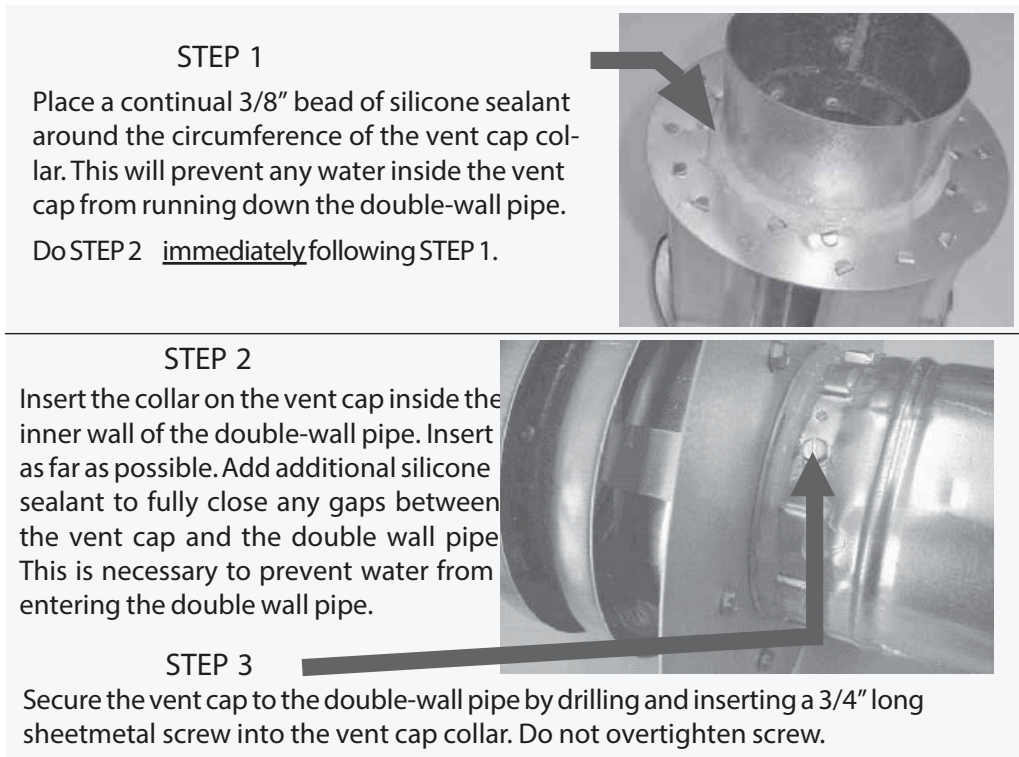

Figure 7. Joining Double-Wall (Type B) Pipe to Vent Terminal Cap (Horizontal or Vertical)

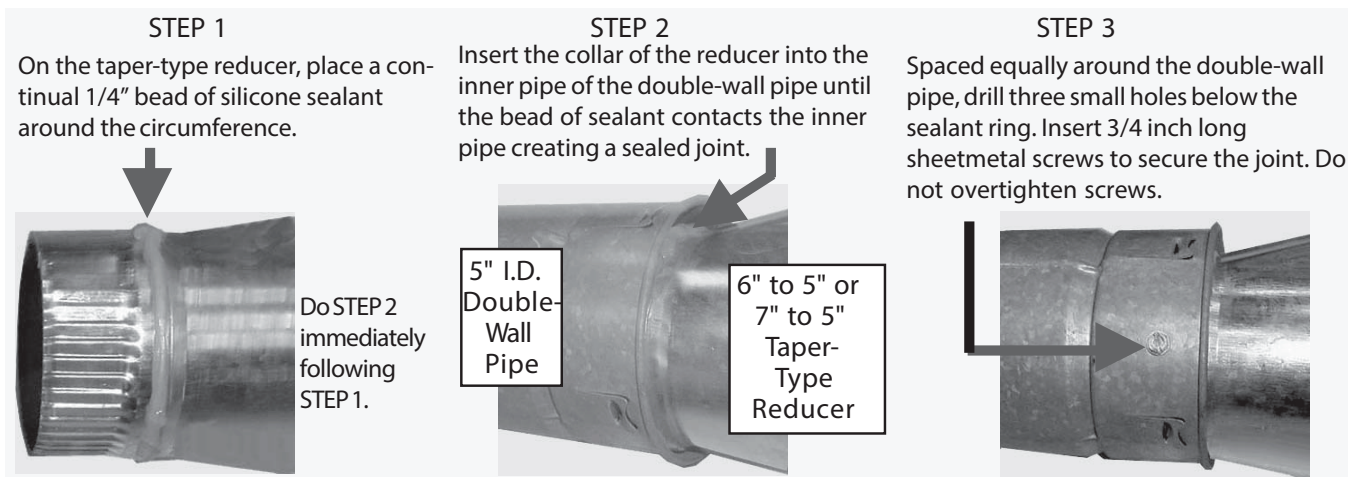

Figure 8. Joining Double-Wall (Type B) Pipe to Single-Wall or Category III Vent Pipe Using Tapered Reducer

Specific Venting Requirements: Support

Support horizontal runs every six feet (1.8 meters). Support vertical runs of Type B double-wall or Category III vent pipe in accordance with the requirements of the pipe manufacturer. Support single-wall vertical pipe in accordance with accepted industry practices. Do not rely on the heater or the adapter box for support of either horizontal or vertical pipes. Use noncombustible supports on vent pipe.

NOTE: The double-wall vent terminal pipe does not attach to the concentric adapter box and must be supported during installation.

Specific Venting Requirements: Clearance

Do not enclose the vent pipe or place pipe closer than 6 inches (152 mm) to combustible material.

Specific Venting Requirements: Concentric Adapter Box

The concentric adapter box (PN 205885) is included in the vent/combustion air kit. Installation instructions depend on whether the vent system is horizontal (option CC6) or vertical (option CC2). All separated-combustion installations require a concentric adapter box as shown in [Figure 9](#).

View of Heater Connection Side

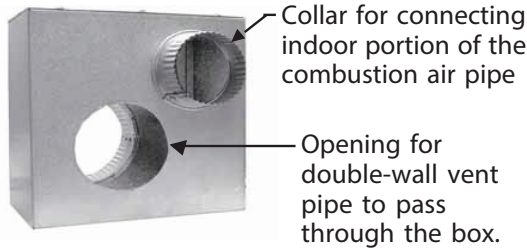

View of Vent Terminal Connection Side

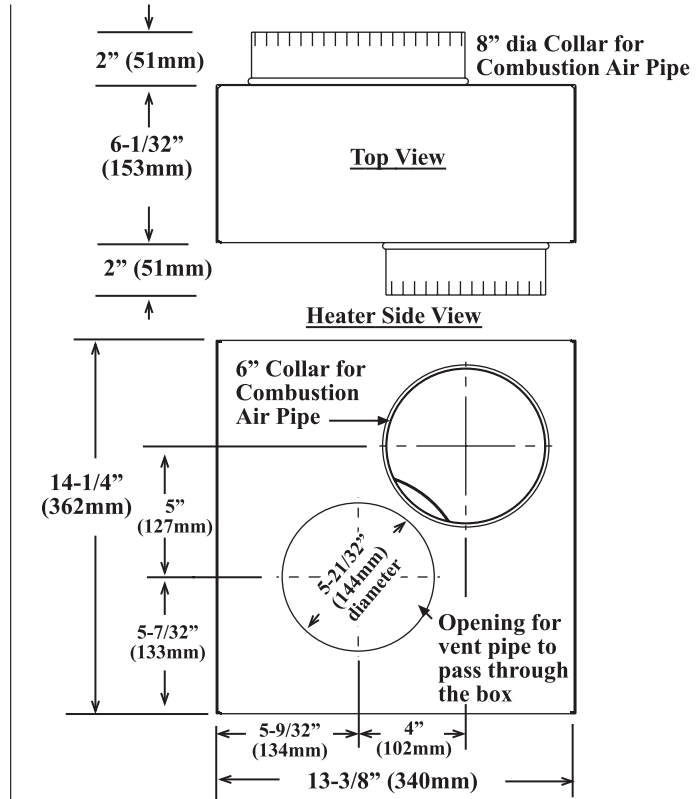
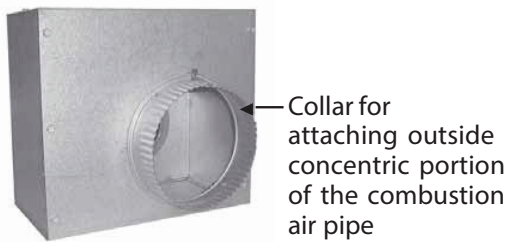

Concentric Adapter Box Airflow

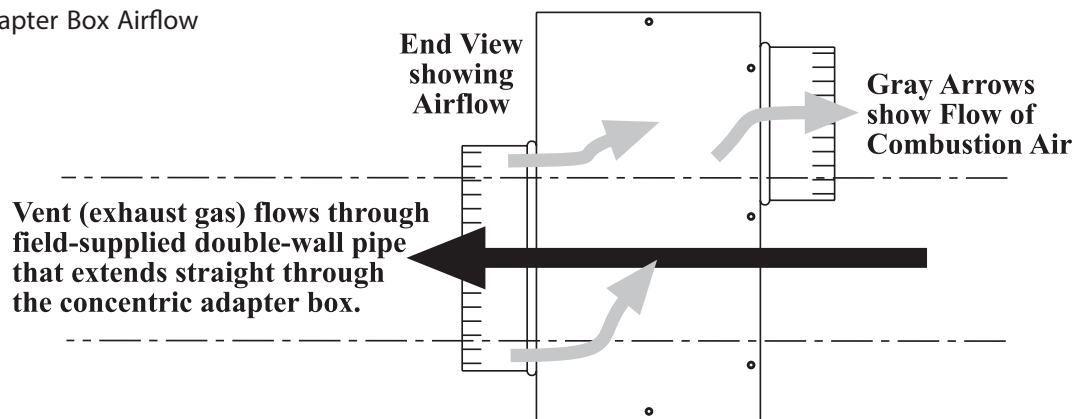

Figure 9. Concentric Adapter Box

Specific Venting Requirements: Concentric Adapter Box Pipe Connections

NOTE: Do NOT make actual connections until after reading the instructions and length requirements for installing the vent/combustion air kit. The connection requirements are the same for both vertical and horizontal systems, but the length of the double-wall pipe will vary.

When pipe diameters differ, depending on direction of airflow, join the pipes with either a tapered reducer or enlarger as shown in [Figure 10](#).

INSTALLATION—CONTINUED

Venting/Combustion Air Connections—Continued

Specific Venting Requirements: Concentric Adapter Box Pipe Connections—Continued

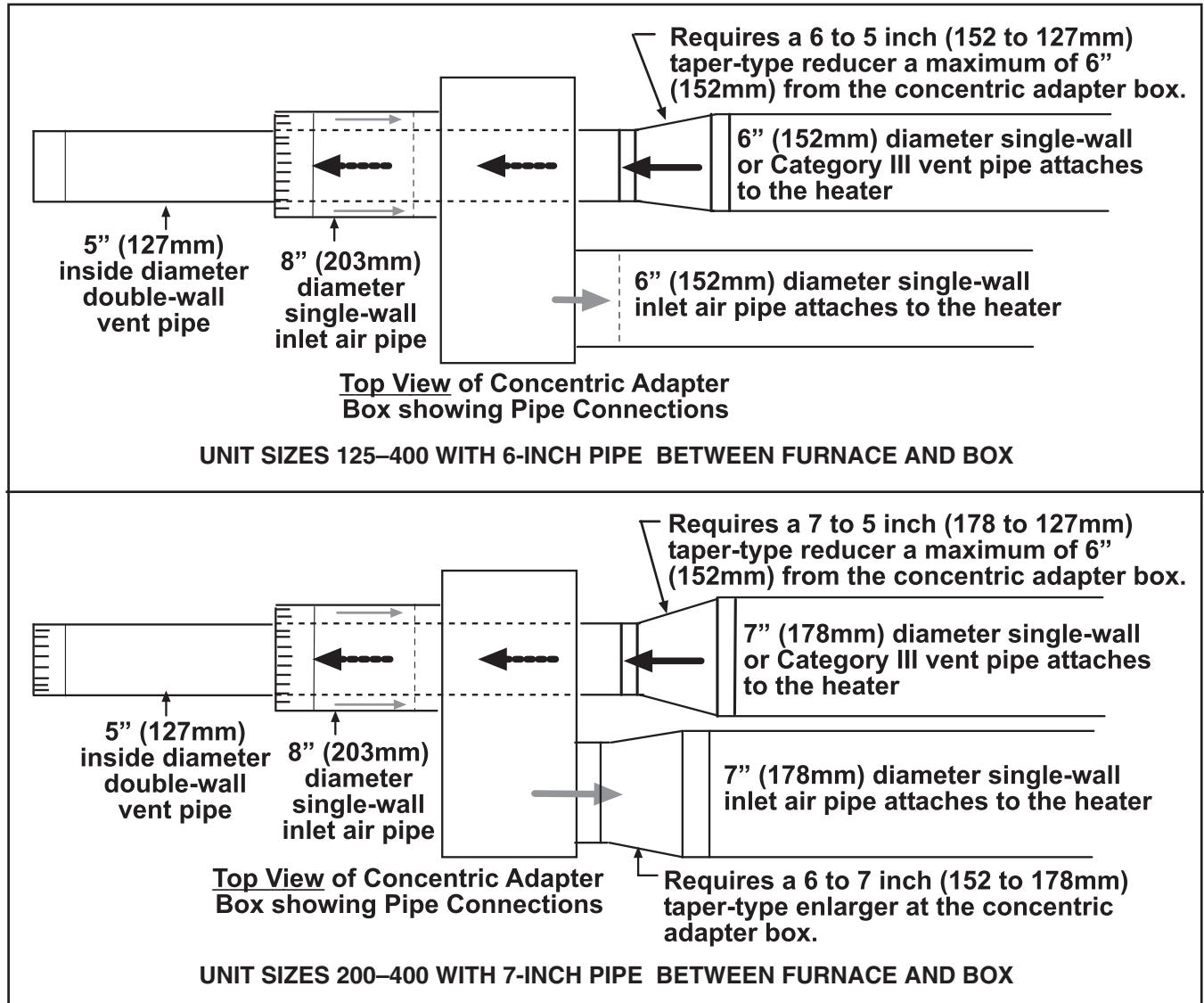

Figure 10. Concentric Adapter Box Connections

Vent Terminal Options

Vent terminal options CC2 (vertical vent configuration) and CC6 (horizontal vent configuration) are shown in [Figure 11](#).

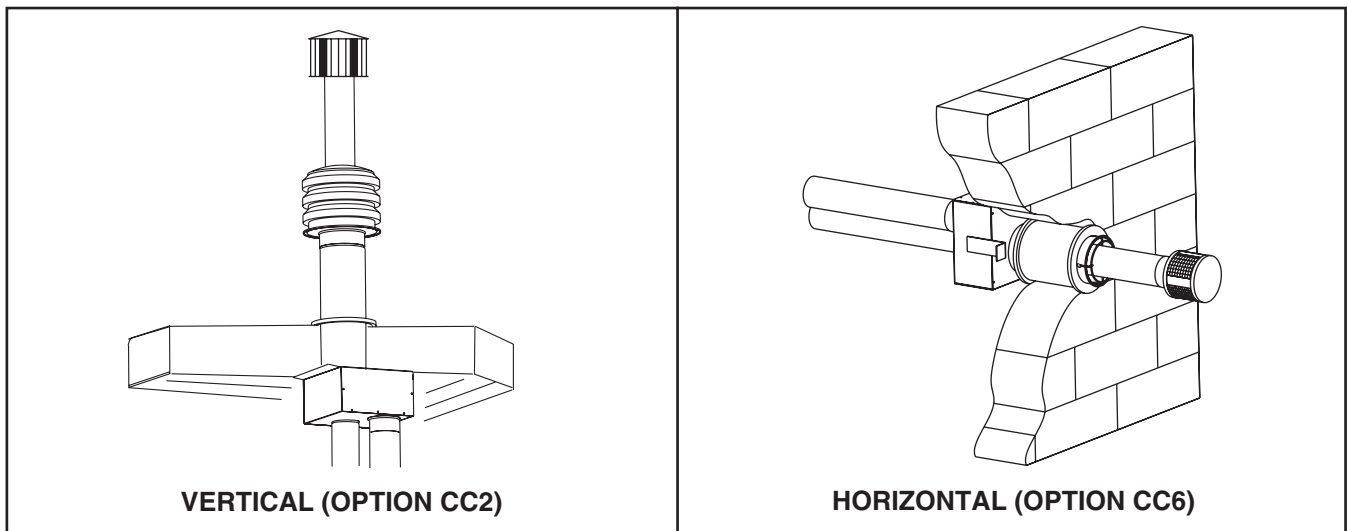

Figure 11. Horizontal and Vertical Venting Options

Vertical Vent Terminal (Option CC2) Installation

- Field-supplied components required for installation of the vertical vent kit are as follows:
 - a. Vent and combustion air piping in accordance with [Table 7](#)
 - b. Tapered vent pipe diameter reducers and/or increasers, as required
 - c. Thimble (not required if wall is of non-combustible construction)
 - d. Flashing
 - e. Sheet metal screws, tape, and sealant, as required
- Factory-supplied components for installation of the vertical vent kit are listed in [Table 8](#).

Table 8. Vertical Vent Terminal/Combustion Air Package (Option CC2) Components		
PN	Description	Quantity
205896	Kit package	1
205885	Concentric adapter box (see Figure 9)	1
110052	Exhaust vent terminal assembly (see Figure 12)	1
53330	Combustion air inlet assembly (see Figure 12)	1
207232	Concentric adapter box bracket	2
53335	High-temperature silicone sealant, tube	1

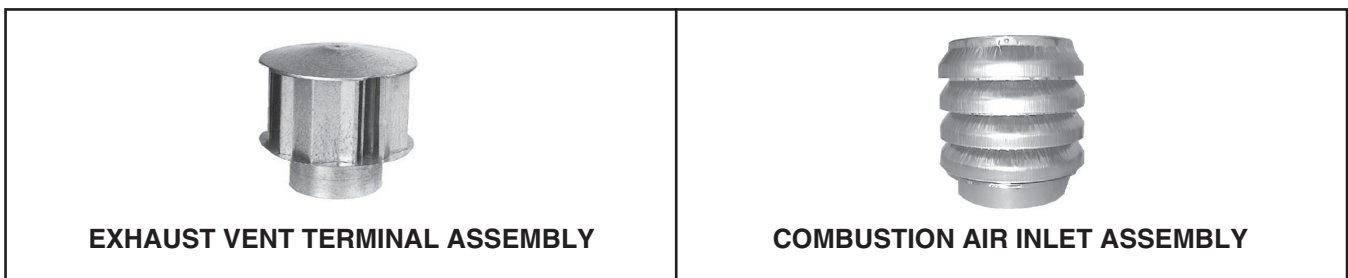

Figure 12. Option CC2 Components

INSTALLATION—CONTINUED

Venting/Combustion Air Connections—Continued

Vertical Vent Terminal (Option CC2) Installation—Continued

⚠ DANGER ⚠

To prevent combustion products from entering the occupied space, all vent terminals must be positioned or located away from fresh air intakes, doors, and windows. Failure to comply could result in severe personal injury or death and/or property damage.

1. Determine vent terminal location on roof:
 - a. If more than one vertical vent terminal is being installed, minimum spacing between vent center lines is determined by minimum outdoor design temperature (coldest outdoor condition at installation site). Refer to [Table 9](#) to ensure that location complies with minimum outdoor design temperature requirements.

Minimum Outdoor Design Temperature	Minimum Spacing Between Center Lines of Vertical Vent Pipes (Inches (mm))
≥31°F (≥0°C)	36 (914)
-10 to 30°F (-23 to -1°C)	60 (1524)
< -10°F (< -23°C)	84 (2134)

- b. Select location away from fresh air intakes, allowing space for concentric adapter box inside. Vent terminal must be located away from adjacent buildings as shown in [Figure 13](#).
2. Install vent pipe and combustion air pipe runs:
 - a. Connect piping to heater in accordance with specifications listed in [Specific Venting Requirements: Piping](#) and [Specific Venting Requirements: Venter Outlet and Combustion Air Inlet Connections](#) sections.
 - b. Seal all joints in accordance with specifications listed in [Specific Venting Requirements: Joints and Sealing](#) section. Due to high temperature considerations, do not enclose exhaust pipe or place pipe closer than 6 inches (152 mm) to combustible material.
 - c. Extend piping runs close to roof at location selected in step 1 and support piping in accordance with specifications listed in [Specific Venting Requirements: Support](#) section.

NOTE: The vent pipe will extend through the roof after the concentric adapter box is installed. The indoor combustion air pipe will end at the box.

3. Cut hole through roof for combustion air pipe.
 - a. Ensure that location and orientation of concentric adapter box are correct and mark and cut hole.
 - b. Ensure that hole accommodates 8-inch (203-mm) combustion air pipe. Thimble may be required depending on building construction and/or local codes. Larger diameter combustion air pipe serves as clearance for vent pipe on non-combustible construction.

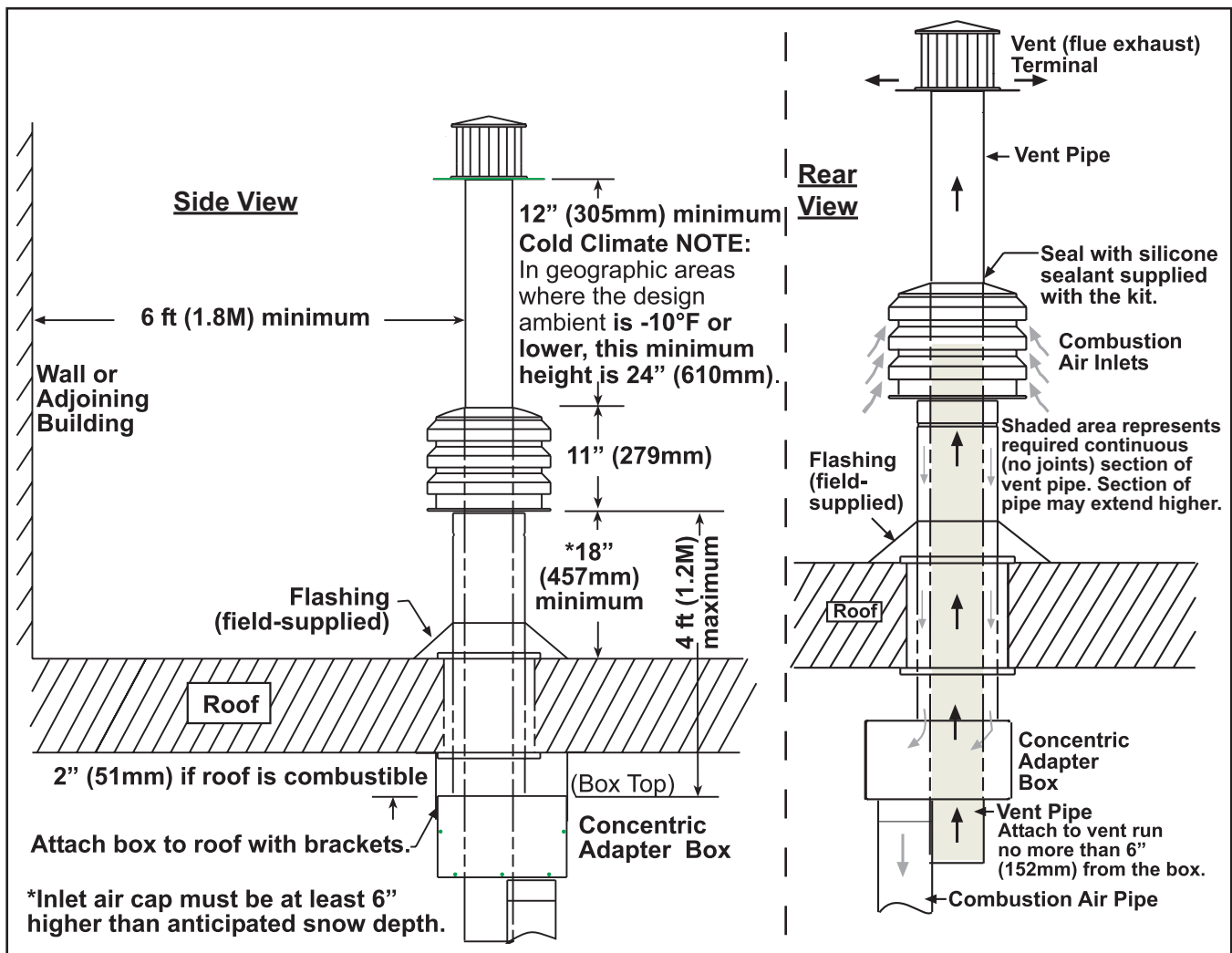

Figure 13. Option CC2 Installation

- Secure longer angles on concentric adapter box brackets (see [Figure 14](#)) to concentric adapter box.

NOTE: The longer angle of the concentric adapter box bracket has five 7/32-inch holes that allow the position of the bracket on the box to be adjusted. The shorter angle has three 7/32-inch holes that allow adjustment to construction.

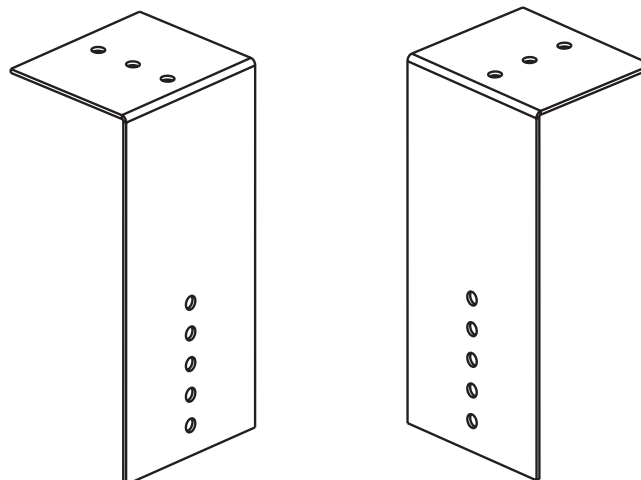

Figure 14. Concentric Adapter Box Brackets

INSTALLATION—CONTINUED

Venting/Combustion Air Connections—Continued

Vertical Vent Terminal (Option CC2) Installation—Continued

5. Connect outside section of combustion air pipe to concentric adapter box (see **Figure 15**):
 - a. Determine length of combustion air pipe so that dimension X in **Figure 15** is equal to bracket length plus roof thickness and plus anticipated snow depth. Ensure that length of combustion air pipe does not exceed 48 inches (1,219 mm) or does not extend **less than** 18 inches (457 mm) above roof.
 - b. Secure inlet air pipe to collar of concentric adapter box using sheet metal screws. Seal joint and seam using tape or sealant.

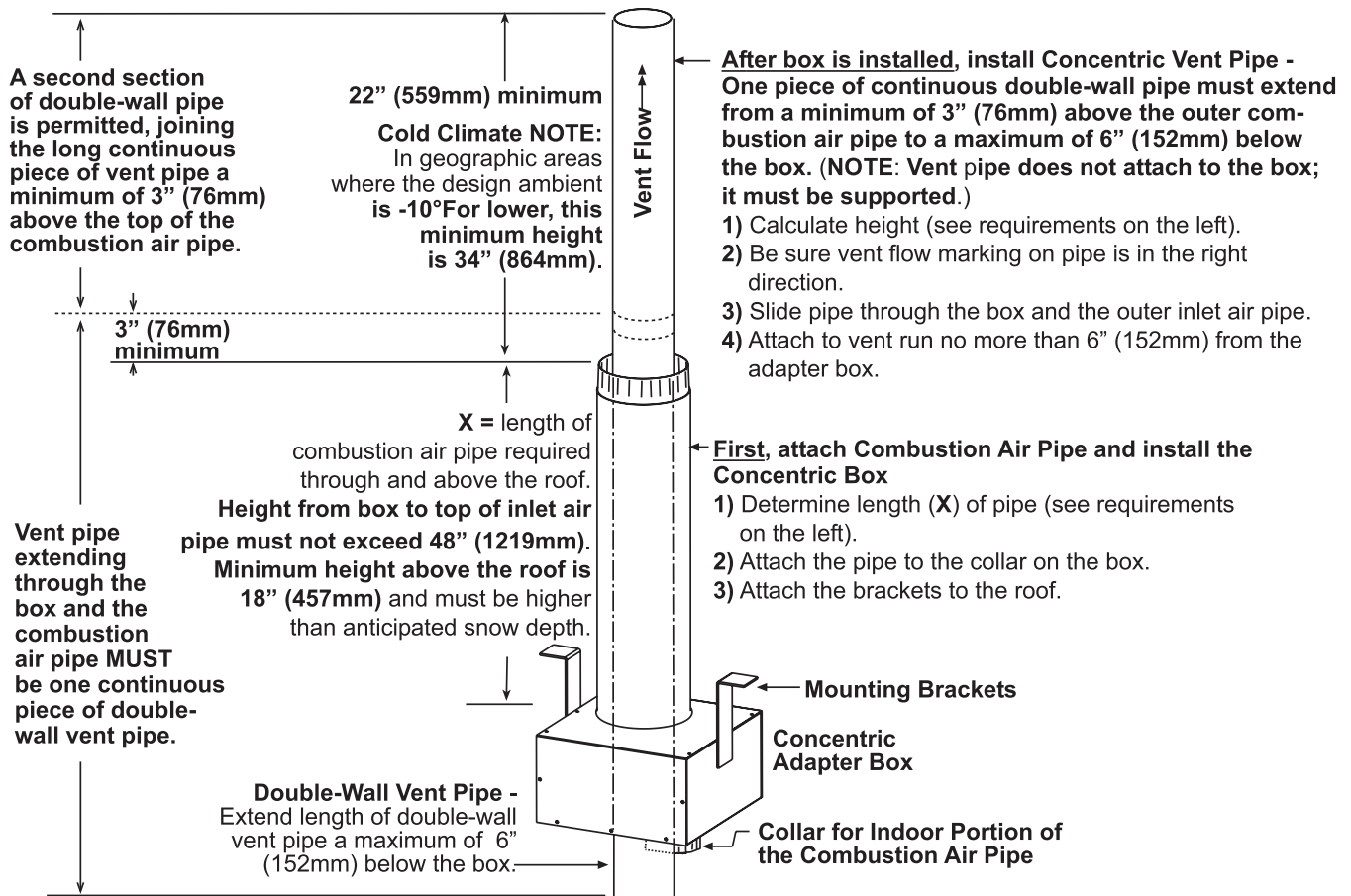

Figure 15. Combustion Air Pipe Installation

6. Secure concentric adapter box to underside of roof (see **Figure 15**):

⚠ CAUTION ⚠

- If the roof is combustible, ensure that brackets are positioned to allow a 2-inch (51 mm) clearance between the concentric adapter box and the roof.
- If any holes are made in the concentric adapter box in error, ensure that they are sealed.

- a. Insert combustion air pipe through roof as shown in **Figure 16**.
- b. Position concentric adapter box to match pipe runs and secure short angles of concentric adapter brackets (see **Figure 14**) to underside of roof using field-supplied hardware.
- c. Install field-supplied flashing around combustion air pipe on roof outside.

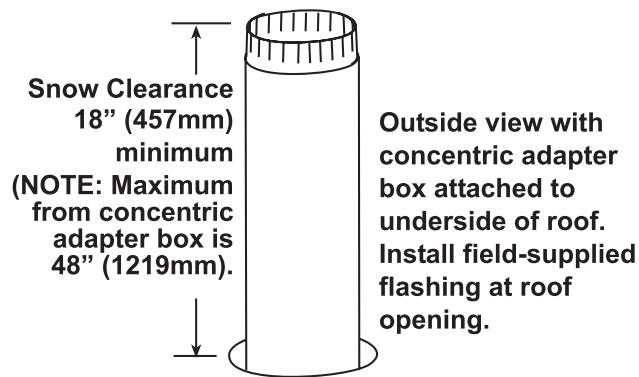

Figure 16. Combustion Air Pipe Through Roof

7. Install double-wall terminal vent pipe:

NOTE: The length of the vent pipe is determined by the installation within maximum and minimum requirements. The vent pipe extending through the box and the inlet air pipe must be one piece of double-wall vent pipe without joints.

- a. Refer to [Figure 15](#) to determine lengths of each pipe segment and to calculate total length required. Determine length by adding requirements:
 - (1) Starting at bottom, vent pipe can extend maximum of 6 inches (152 mm) below box
 - (2) Plus 6 inches (152 mm) through box
 - (3) Plus length of brackets above box
 - (4) Plus width of roof
 - (5) Plus height of outside combustion air pipe above roof
 - (6) Plus minimum of 3 inches (76 mm) beyond top of inlet air pipe
 - (7) Total is minimum length of vent pipe section—if actual piece of vent pipe is longer, extend it farther above combustion air pipe—do not extend it more than 6 inches (152 mm) below box
- b. Ensure that double-wall terminal vent pipe is in proper direction and slide end of pipe into box and out through combustion air pipe. Position vent pipe to lengths determined above.

NOTE: The double-wall vent pipe does not attach to the box. The installer must provide support.

- c. Connect double-wall vent pipe to single-wall or Category III vent pipe run using tapered reducer in accordance with [Figure 8](#).
 - d. Seal completely around circumference of pipe and opening of box using silicone sealant.
8. Install combustion air inlet (see [Figure 17](#)):
- a. On outside, slide combustion air inlet over vent pipe and fasten collar to combustion air pipe using sheet metal screws.
 - b. Seal opening at top between vent pipe and combustion air inlet to prevent water leakage using silicone sealant.
9. Install exhaust vent terminal (see [Figure 17](#)) in accordance with [Figure 7](#).
10. Install indoor combustion air pipe:
- a. Secure single-wall combustion air pipe run to collar on concentric adapter box using sheet metal screws. If using 7-inch piping (unit sizes 200–400), install tapered enlarger as shown in [Figure 10](#).
 - b. Seal pipe joints with tape or sealant.
11. Verify compliance with [Figure 13](#) and with all specific venting requirements listed above.

INSTALLATION—CONTINUED

Venting/Combustion Air Connections—Continued

Vertical Vent Terminal (Option CC2) Installation—Continued

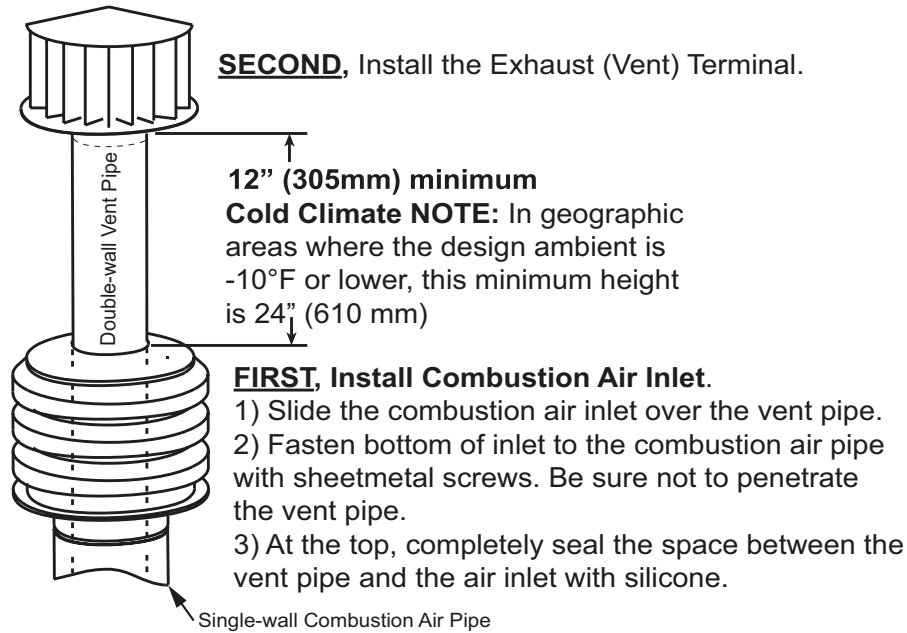

Figure 17. Combustion Air Inlet and Vent Terminal Installation

Horizontal Vent Terminal (Option CC6) Installation

- Field-supplied components required for installation of the horizontal vent kit are as follows:
 - a. Vent and combustion air piping in accordance with [Table 7](#)
 - b. Tapered vent pipe diameter reducers and/or increasers, as required
 - c. Thimble (not required if wall is of non-combustible construction)
 - d. Flashing
 - e. Sheet metal screws, tape, and sealant, as required
- Factory-supplied components for installation of the horizontal vent kit are listed in [Table 10](#).

Table 10. Horizontal Vent Terminal/Combustion Air Package (Option CC6) Components		
PN	Description	Quantity
205883	Kit package	1
205885	Concentric adapter box (see Figure 9)	1
53316	Assembly, screened exhaust (see Figure 18)	1
205894	Inlet guard (see Figure 18)	1
37661	Screw, sheet metal, #10-16 × 1/2	4
207232	Concentric adapter box bracket	2
53335	High-temperature silicone sealant, tube	1

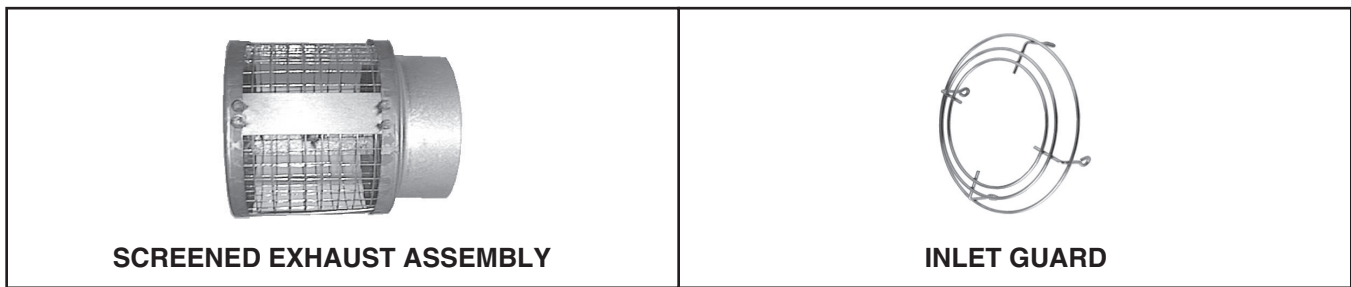

Figure 18. Option CC6 Components

⚠ DANGER ⚠

- To prevent combustion products from entering the occupied space, all vent terminals must be positioned or located away from fresh air intakes, doors, and windows. Failure to comply could result in severe personal injury or death and/or property damage.
- In climates with below freezing temperatures, condensate may form icicles on the vent terminal. Locate the terminal where falling icicles do not present a hazard.
- Consider local snow depth conditions. The vent must be at least 6 inches (152 mm) above the anticipated snow depth.

1. Determine vent terminal location on outside wall:
 - a. Refer to [Table 7](#) to ensure that location complies with vent length requirements.
 - b. For most applications, ensure that vent terminal is level with heater mounting height.
 - c. Allow downward pitch of 1/4-inch per foot (6 mm per 305 mm) for condensate drain.

NOTE: Local codes supersede all provisions in these instructions and in *National Fuel Gas Code Z223.1*.

- d. Ensure that distance of vent terminal from adjacent public walkways and buildings and window and building openings complies with local codes. Absent any local codes, distance must comply with *National Fuel Gas Code Z223.1*.

⚠ WARNING ⚠

Avoid positioning the vent terminal above a walkway as there may be a small amount of condensate that drips from the end of the vent/combustion air terminal. In cold climates, the condensate may form ice.

⚠ CAUTION ⚠

Products of combustion can cause discoloration of some building finishes and deterioration of masonry materials. A clear silicone sealant normally used to protect concrete driveways may be used to protect masonry materials from discoloration and deterioration. If discoloration is an esthetic problem relocate the vent or install a vertical vent.

- e. Refer to [Table 11](#) to ensure that location complies with minimum clearance requirements.

INSTALLATION—CONTINUED

Venting/Combustion Air Connections—Continued

Horizontal Vent Terminal (Option CC6) Installation—Continued

Table 11. Minimum Clearance Requirements for Horizontal Vent Terminal	
Component/Structure	Minimum Clearance, All Directions Unless Specified (Feet (Meters))
Forced air inlet within 10 feet (3.1 meters)*	3 (0.9) above
Combustion air inlet of another appliance	6 (1.8)
Mechanical air supply inlet to any building	Canada: 6 (1.8)
Any building opening (door, window, or gravity air inlet)	4 (1.2) horizontal and below
	1 (0.3) above
Gas meter,** electric meter, and relief equipment	US: 4 (1.2) horizontal
	Canada: 6 (1.8) horizontal
Gas regulator**	US: 3 (0.9) horizontal
	Canada: 6 (1.8) horizontal
Adjoining building or parapet	6 (1.8)
Adjacent public walkway	7 (2.1) above
Grade (ground level)	3 (0.9) above
*Does not apply to the inlet of a direct vent appliance.	
**Do not terminate the vent directly above a gas meter or service regulator.	

2. Install vent pipe and combustion air pipe runs:
 - a. Connect piping to heater in accordance with specifications listed in [Specific Venting Requirements: Piping](#) and [Specific Venting Requirements: Venter Outlet and Combustion Air Inlet Connections](#) sections.
 - b. Seal all joints in accordance with specifications listed in [Specific Venting Requirements: Joints and Sealing](#) section. Due to high temperature considerations, do not enclose exhaust pipe or place pipe closer than 6 inches (152 mm) to combustible material.
 - c. Extend piping runs close to wall location selected in step 1 and support piping in accordance with specifications listed in [Specific Venting Requirements: Support](#) section.
3. Cut hole through outside wall for combustion air pipe.
 - a. Ensure that outside wall construction thickness is between 1 inch (25 mm) minimum and 48 inches (1,219 mm) maximum.
 - b. Ensure that hole accommodates 8-inch (203-mm) combustion air pipe. Thimble may be required depending on building construction and/or local codes. Larger diameter combustion air pipe serves as clearance for vent pipe on noncombustible construction.
4. Secure longer angles on concentric adapter box brackets (see [Figure 14](#)) to concentric adapter box.

NOTE: The longer angle of the concentric adapter box bracket has five 7/32-inch holes that allow the position of the bracket on the box to be adjusted. The shorter angle has three 7/32-inch holes that allow adjustment to construction.

5. Connect outside section of combustion air pipe to concentric adapter box (see [Figure 19](#)):
 - a. Determine length of combustion air pipe as follows:
 - (1) Bracket length from box to wall
 - (2) Plus wall thickness
 - (3) Plus 2 inches (51 mm) beyond wall
 - b. Secure inlet air pipe to collar of concentric adapter box using sheet metal screws. Seal joint and seam using tape or sealant.
6. Secure concentric adapter box to wall (see [Figure 19](#)):

⚠ CAUTION ⚠

- If the wall is combustible, ensure that brackets are positioned to allow a 2-inch (51 mm) clearance between the concentric adapter box and the wall.
- If any holes are made in the concentric adapter box in error, ensure that they are sealed.

- a. Insert combustion air pipe out through wall.
- b. Secure short angles (see [Figure 14](#)) of concentric adapter box brackets to wall.
- c. Seal or flash inlet air pipe on outside using sealant and/or field-supplied flashing.

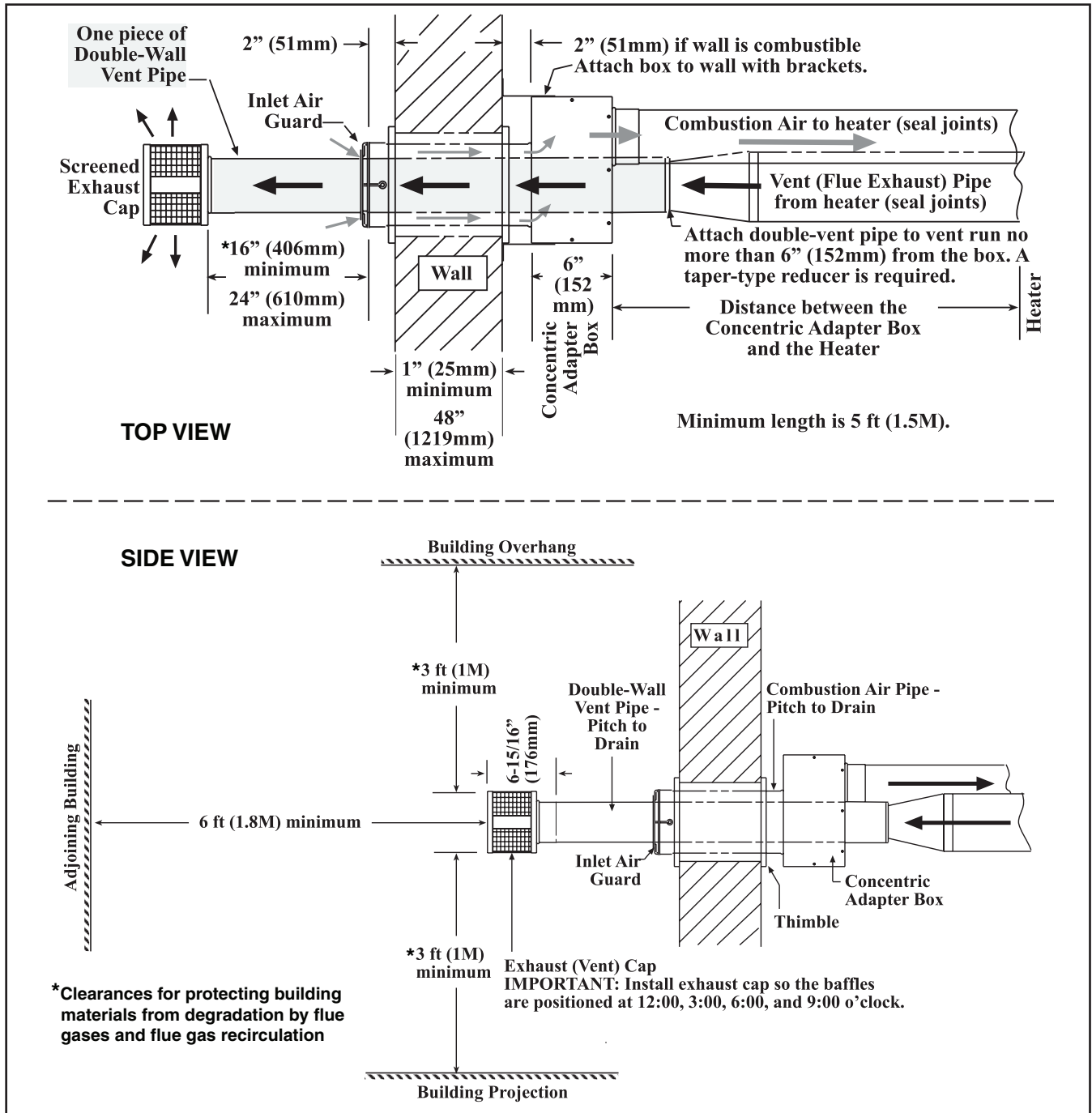

Figure 19. Option CC6 Installation

INSTALLATION—CONTINUED

Venting/Combustion Air Connections—Continued

Horizontal Vent Terminal (Option CC6) Installation—Continued

7. Install inlet guard:
 - a. Position inlet guard over end of combustion air pipe in accordance with [Figure 19](#).
 - b. Secure air inlet guard to inlet air pipe using four 1/2-inch-long screws provided.

NOTE: If vent pipe is inserted from outside, the exhaust cap may be attached before the double-wall vent pipe is installed. If cap is attached first, ensure that the baffle strips are positioned correctly when attaching the vent terminal pipe to the vent run (refer to step 8d below).

8. Install double-wall terminal vent pipe:

NOTE: The length of the vent pipe is determined by the installation within maximum and minimum requirements. The vent pipe extending through the box and the inlet air pipe must be one piece of double-wall vent pipe without joints.

- a. Refer to [Figure 19](#) to determine lengths of each pipe segment and to calculate total length required. Transition to single-wall or Category III vent pipe run must be made maximum of 6 inches (152 mm) from heater side of box.
- b. Ensure that double-wall terminal vent pipe is in proper direction and slide end of pipe through box. Position pipe so that it will extend between 16–24 inches (406–610 mm) past end of combustion air pipe and no more than 6 inches (152 mm) out of box toward heater.

NOTE: The double-wall vent pipe does not attach to the box. The installer must provide support.

- c. Connect 5-inch double-wall vent pipe to 6- or 7-inch single-wall or Category III vent pipe run using tapered reducer (see [Figure 8](#)).
 - d. Ensure that exhaust cap is aligned so that its baffle strips are positioned on horizontal and vertical center lines (see [Figure 19](#)). Install cap in accordance with [Figure 7](#).
 - e. Ensure that double-wall section of vent pipe has slight downward drop of 1/4-inch per foot (6 mm per 305 mm) toward vent terminal end.
 - f. Seal completely around circumference of pipe and opening of box using silicone sealant.
9. Install indoor section of combustion air pipe:
 - a. Secure single-wall combustion air pipe run to collar on concentric adapter box using sheet metal screws. If using 7-inch piping (unit sizes 200–400), install tapered enlarger as shown in [Figure 10](#).
 - b. Seal pipe joints with tape or sealant.
 10. Verify compliance with [Figure 19](#) and with all specific venting requirements listed above.

Piping Connections

Gas Supply Pressure

The unit is equipped for a maximum gas supply pressure of 1/2 psi, 3.5 kPa, or 14 IN WC.

NOTES:

Supply pressure higher than 1/2 psi requires the installation of an additional service regulator external to the unit.

PRESSURE TESTING SUPPLY PIPING

- Test pressures *above* 1/2 psi—disconnect the heater and manual valve from the gas supply line to be tested. Cap or plug the supply line.
 - Test pressures *below* 1/2 psi—before testing, close the manual valve on the heater.
-

⚠ DANGER ⚠

- All components of a gas supply system must be leak tested prior to placing equipment in service. NEVER TEST FOR LEAKS WITH AN OPEN FLAME. Failure to comply could result in personal injury, property damage, or death.
- Pipe joint compounds (pipe dope) shall be resistant to the action of liquefied petroleum gas or any other chemical constituents of the gas being supplied.

- All piping must be in accordance with requirements outlined in the *National Fuel Gas Code* ANSI/Z223.1 (latest edition) or the *Natural Gas and Propane Installation Code* CSA B149.1 (refer to [Installation Codes](#) section).
- Gas supply piping installation should conform with good practice and with local codes.
- The heater is orificed for operation with natural gas having a heating value of 1,000 (±50) BTU per cubic foot or with propane gas having a heating value of 2,550 (±100) BTU per cubic foot. Sizing of gas supply lines depends on piping capacity and is based on cubic feet per hour based on a 0.3 IN WC pressure drop, a 0.6 specific gravity for natural gas at 1,000 BTU per cubic feet, and a 1.6 specific gravity for propane at 2,550 BTU per cubic feet. If the gas at the installation does not meet this specification, consult the factory for proper orificing.
- Variables for sizing gas supply lines are listed in [Table 12](#). When sizing supply lines, consider possibilities of future expansion and increased requirements. Refer to *National Fuel Gas Code* for additional information on line sizing.

Table 12. Gas Supply Line Sizes

Length of Pipe (Feet)	Diameter of Pipe (Inches)											
	1/2		3/4		1		1-1/4		1-1/2		2	
	Natural Gas	Propane Gas	Natural Gas	Propane Gas	Natural Gas	Propane Gas	Natural Gas	Propane Gas	Natural Gas	Propane Gas	Natural Gas	Propane Gas
Cubic Feet per Hour												
20	92	56	190	116	350	214	730	445	1100	671	2100	1281
30	73	45	152	93	285	174	590	360	890	543	1650	1007
40	63	38	130	79	245	149	500	305	760	464	1450	885
50	56	34	115	70	215	131	440	268	670	409	1270	775
60	50	31	105	64	195	119	400	244	610	372	1105	674
70	46	28	96	59	180	110	370	226	560	342	1050	641
80	43	26	90	55	170	104	350	214	530	323	990	604
90	40	24	84	51	160	98	320	195	490	299	930	567
100	38	23	79	48	150	92	305	186	460	281	870	531
125	34	21	72	44	130	79	275	168	410	250	780	476
150	31	19	64	39	120	73	250	153	380	232	710	433
175	28	17	59	36	110	67	225	137	350	214	650	397
200	26	16	55	34	100	61	210	128	320	195	610	372

Supply Piping Connections

- Gas connections are shown in [Figure 20](#) and gas connections sizes are listed in [Table 13](#).
- Install a ground joint union and manual shutoff valve upstream of the unit control system. The 1/8-inch plugged tapping in the shutoff valve provides connection for the supply line pressure test gauge. The *National Fuel Gas Code* requires the installation of a trap with a minimum 3-inch drip leg. Local codes may require a longer drip leg, typically 6-inch (see [Figure 20](#)).
- Seal the opening for the gas supply pipe with the grommet provided.
- After all connections are made, disconnect the pilot supply at the control valve and bleed the system of all air. Reconnect the pilot line and leak test all connections by brushing on a soap solution.

INSTALLATION—CONTINUED

Piping Connections—Continued

Supply Piping Connections—Continued

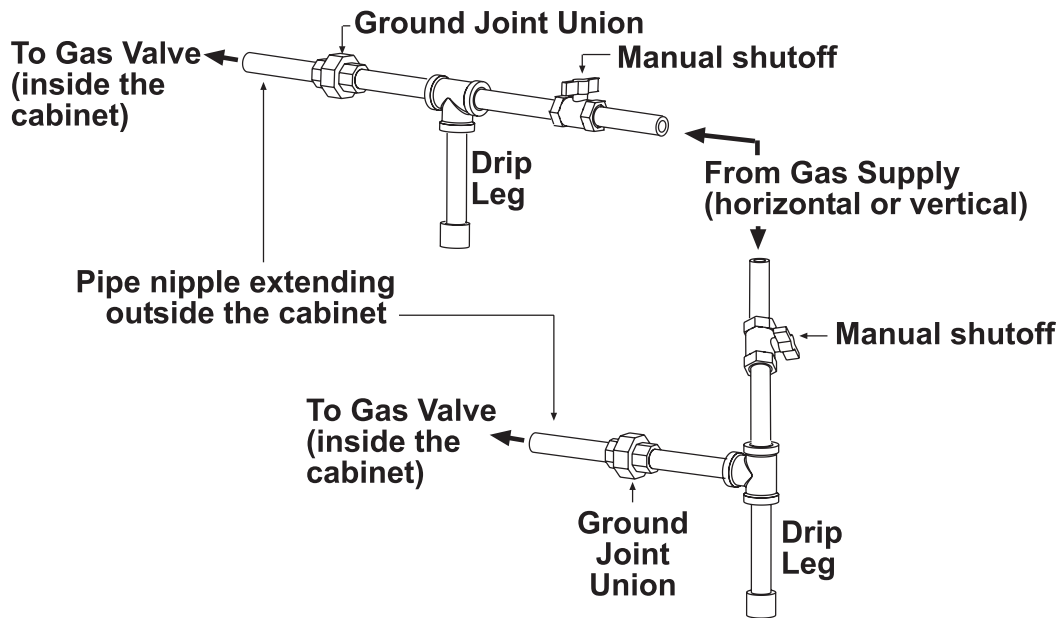

Figure 20. Gas Connections

Table 13. Gas Connection Sizes

Gas Type	Unit Size	
	125–250	300–400
	Connection Size (Inches)	
Natural gas	1/2	3/4
Propane	1/2	

NOTE: The above are not supply line sizes. They are gas connection sizes for a standard unit.

Condensate Drain Installation

Model SCE furnaces are certified for installation upstream or downstream from a cooling coil. When installed downstream from a refrigeration system, condensation will form and, therefore, adequate provision must be made to dispose of condensate.

NOTE: A 4-inch (102-mm) minimum clearance is required under the furnace if a 90-degree street elbow is used.

1. Install drain flange (option CS1, PN 31765) in bottom of furnace casing as shown in [Figure 21](#) and secure using two machine screws (#10-32 × 1-inch-long) and nuts.
2. Install 3/4-inch waste pipe nut in drain flange.
3. Seal all corners and four square holes in bottom pan edge using RTV sealant.
4. Terminate drain outside of building and provide trap to prevent air from entering combustion zone.

NOTE: Periodic cleaning of the condensate collector and disposal system is required.

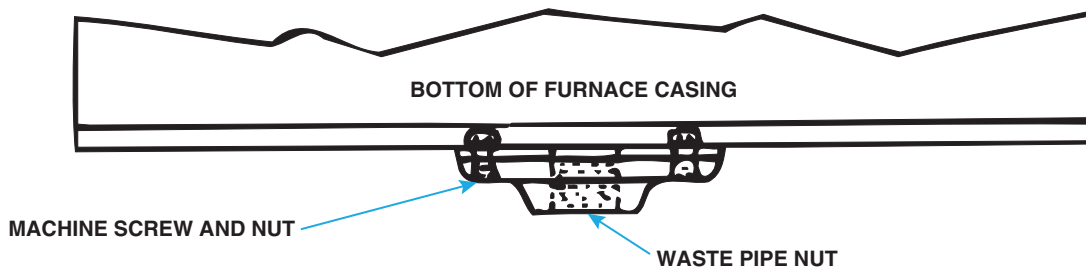

Figure 21. Condensate Drain Connection

Electrical Connections

⚠ CAUTION ⚠

If any of the original wire as supplied with the appliance must be replaced, it must be replaced with wiring material having a temperature rating of at least 105°C, except for the sensor lead and the optional bypass damper combustion air safety circuit (option AG39 or AG40) wires, which must be rated at 150°C.

NOTES:

- Ensure that all wiring is in accordance with the wiring diagram provided with the unit. A specific wiring diagram can be found in the heater junction box. Electrical options are identified on this wiring diagram.
- Refer to separate instruction sheets for any optional equipment provided.
- All electrical wiring must be completed in accordance with local, state, and national codes and regulations and with the *National Electric Code* (ANSI/NFPA 70) or, in Canada, the *Canadian Electric Code*, Part 1 (CSA C.22.1).
- Check any local ordinances or gas company requirements that apply.
- Check the rating plate on the heater for the supply voltage and for current requirements. A separate line voltage supply with fused disconnect switch should be run directly from the main electrical panel to the unit, making connections in the junction box (see [Figure 1](#)).
- Seal all electrical entrance openings with field-supplied bushings. Refer to [Table 14](#) for field-supplied wiring sizes—from disconnect to electrical box—for connection to the motor contactor or starter.

Table 14. Field-Supplied Wiring Sizes

Voltage/Phase	Motor HP	Wire Gauge	BX Cable
120/1	1/4– 1/2	14	3/8
208–230/1	1	12	
	1–1-1/2	14	
208–230/3	1/4–3	14	
460/3	5	12	
	1/4–5	14	
575/3	1/2–5	14	

- A disconnect switch is available as optional equipment or may be provided locally. When installing the disconnect switch, ensure that the conduit and switch housing are clear of all service panels. Allow at least 4 feet (1.2 meters) of service room between the disconnect switch and any removable service panels. When providing or replacing fuses in a fusible disconnect switch, use dual-element time delay fuses sized at 1.25 × maximum total input amps.

Control Wiring

- The heater is equipped with a low-voltage (24V) control circuit. Refer to [Table 15](#) for field-supplied control wiring sizes.

INSTALLATION—CONTINUED

Electrical Connections—Continued

Control Wiring—Continued

Distance from Unit to Control (Feet (Meters))	Minimum Recommended Wire Gauge (AWG)	Total Wire Length (Feet (Meters))
75 (23)	#18	150 (46)
125 (38)	#16	250 (76)
175 (53)	#14	350 (107)

- Refer to [Table 16](#) for amp ratings of optional controls.

Control	Ampere Rating (Amps)
Fan control coil	0.12
Time delay heater	0.14
RBM relay coil	0.12
Contactor coil	0.45
Spark ignition system	0.10
Maxitrol gas control system	0.51
Honeywell gas valve	0.50
White-Rodgers gas valve	0.60

CONTROLS

Thermostat

⚠ CAUTION ⚠

Control circuit amps should be within the anticipator amp rating of the [thermostat](#) used.

- A [thermostat](#) is not provided with the furnace. Use either an optional or a field-provided low-voltage (24V) [thermostat](#). Install the [thermostat](#) according to the manufacturer's instructions.
- A low-voltage [thermostat](#) is equipped with a heat anticipator that levels out unit cycling for optimum temperature control. Set the anticipator at 1.0 amps for standard controls.

Combustion Air Proving Switch

⚠ DANGER ⚠

Safe operation requires proper venting flow. Never bypass the combustion air proving switch or attempt to operate the unit without the venter running and proper flow in the vent system. Hazardous conditions could result.

- The combustion air proving switch ensures that proper combustion airflow is available. The switch is a single-pole, double-throw switch that senses pressure caused by the flow of combustion air from the venter. The switch is designed to close when a decreasing pressure is sensed in the outlet duct of the gas collection box.
- At startup when the furnace is cold, the sensing pressure is at the most negative level. As the furnace and the flue system warm up, the sensing pressure becomes less negative. After the system has reached equilibrium (approximately 20 minutes), the sensing pressure levels off. If a restriction or if excessive flue length or turns cause the sensing pressure to become less than the switch setpoint, the pressure switch will function to shut off the main burners. The main burners will remain off until the system has cooled and/or the flue system resistance is reduced. Refer to [Table 17](#) for approximate water column negative pressure readings and combustion air proving switch setpoints for sea level operating conditions.

Table 17. Combustion Air Proving Switch Settings at Sea Level Operating Conditions			
Unit Size	Factory Setpoint	Startup Cold	Equilibrium
Units Without Option AG39 or AG40			
All	-0.58 (±0.05) IN WC	-1.0 IN WC	-0.70 IN WC
Units with Option AG39 or AG40			
125–225	-1.00 (±0.02) IN WC	-1.30 (±0.20) IN WC	-1.05 (±0.10) IN WC
250, 300, 400	-0.70 (±0.05) IN WC	-1.20 (±0.20) IN WC	-0.95 (±0.10) IN WC

Blower Fan Control

NOTE: To replace the blower fan control on units manufactured *before* NOV 2004, a replacement kit (PN [209184](#)) is required.

The blower fan is controlled as follows:

- After the gas valve opens, there is a time delay of blower fan operation to prevent the discharge of cold air.
- Blower fan operation continues after the [thermostat](#) is satisfied, as determined by the fan time delay.
- To ensure that the blower fan can continue to operate, the power supply to the furnace MUST NOT be interrupted except for when servicing the unit.

NOTE: If the customer wants the furnace off at night, the gas valve circuit SHOULD BE OPENED by a single-pole switch wired in series with the [thermostat](#). Some thermostats are provided with this feature. Multiple units controlled from a single [thermostat](#) are shut off in the same manner. For proper operation, ensure that the blower fan control is wired correctly.

Limit Control

All models are equipped with an automatic, non-adjustable, reset limit control that acts to interrupt the electric supply to the redundant main operating valve in case of motor failure or lack of airflow due to restrictions at the inlet or outlet.

Variable Frequency Drive

- If the system is equipped with an optional variable frequency drive, the motor will operate at speeds determined by the electrical frequency: 60 Hertz (Hz) is maximum speed. Speed must be within the temperature rise range of a model SCE series 6 heater: 30–90°F.
- Follow the variable frequency controller manufacturer's instructions that are packaged with the heater (in the owner's envelope) to program the variable frequency drive settings. The formula for motor speed is $N = 120 \times f/p$ where N = speed, f = frequency, p = number of poles, a 3,600-rpm motor has two poles, and an 1800-rpm motor has four poles. For example, for an 1,800-rpm motor at 60Hz, $N = 120 \times 60/4 = 1800$ (1,800 = synchronous speed, assume 2% slip).
- The motor will run between 1,750 and 1,790 rpm at full load depending on design. For the same motor run at 45Hz, $120 \times 45/4 = 1350$ (1,350 rpm less 2% slip = about 1,300 rpm).

Combination Gas Valve

⚠ WARNING ⚠

The combination gas valve is the prime safety shutoff. To ensure positive closure, all gas supply lines must be free of dirt or scale before connecting them to the unit.

All furnaces are equipped with a 24V combination gas valve that includes the automatic electric ON/OFF valve controlled by the room [thermostat](#), the pressure regulator, the safety pilot valve, and the manual shutoff valve. The standard combination gas valve allows for single-stage control from a single-stage, 24V [thermostat](#).

CONTROLS—CONTINUED

Optional Two-Stage Control (Heating Only Application)

The standard combination control valve is replaced with a two-stage combination gas control valve providing for low fire or high fire operation controlled by a two-stage [thermostat](#). The first stage (low fire) is factory-set (not field-adjustable). Both low fire and high fire stages are controlled by a Servo regulator that maintains constant gas input under wide variations in gas supply pressure. Refer to the instructions provided with the unit for gas valve specifications, wiring, and operating instructions.

Optional Two-Stage Control (Makeup Air Application)

- Two-stage makeup air units are equipped with a two-stage gas valve, but instead of control from a two-stage room [thermostat](#), the outlet air temperature is monitored and controlled by a two-stage ductstat. When discharge air temperature drops to the setpoint, low fire is energized. If low fire cannot satisfy the ductstat setting, high fire is energized.
- Makeup air applications are usually adjusted to maintain discharge air temperature between 65°F and 75°F. In all applications, the allowable temperature rise of the furnace in the installation dictates the limits of the ductstat temperature setting.
- Depending on the option selection, the factory-installed sensor is either field-connected by capillary tubing to the unit-mounted ductstat (see [Figure 22](#)), which is factory-set at 70°F, or electrically-connected to a remote electronic temperature selector (see [Figure 23](#)), which is available with or without a display module.

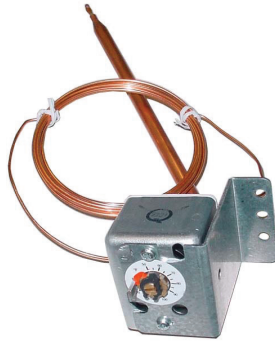

Figure 22. Unit-Mounted Ductstat (Option AG3)



A = TEMPERATURE-SELECTING MODULE
B = ONE-STAGE ADDER MODULE

Figure 23. Remote Temperature Selector (Option AG15 or AG16)

Optional Ductstat with Capillary Tubing (Option AG3)

The unit-mounted ductstat shown in [Figure 22](#) has an adjustable range between 0°F and 100°F with a fixed differential of 3°F. Due to different cfm settings and outside air temperatures, the average downstream outlet temperature may not match the ductstat setting exactly. After the installation is complete, adjust the setpoint of the ductstat to achieve the desired average outlet air temperature.

Optional Ductstat with Electronic Remote Setpoint Module (Option AG15 or AG16)

- The field-installed sensing probe is field-wired to the remote temperature selector shown in [Figure 23](#), which has a temperature operating range to 130°F. The remote modules and sensing probe are shipped separately for field-installation. Follow the wiring diagram provided with the unit and the manufacturer's instructions for wiring and installation. One module is for selecting temperature, one module is a one-stage adder module, and the digital display module is optional.

⚠ CAUTION ⚠

Ensure that the heat/cool selector switch on the remote temperature selector is positioned to *Heat*.

- [Figure 24](#) shows how to access the factory-installed sensor with either the unit-mounted ductstat (see [Figure 22](#)) or the remote temperature selector (see [Figure 23](#)).

1. Remove access panel in ductwork adjacent to control compartment access panel.
2. Element is retained by spring clips.
3. Round gasket and metal retaining plate provide airtight seal for capillary and must be removed to remove the element.

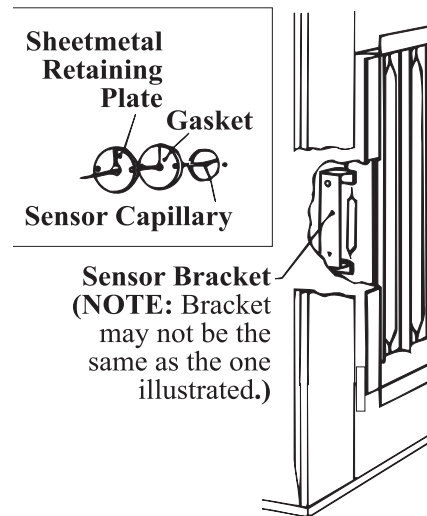

Figure 24. Duct Temperature Sensor Location

Optional Electronic Modulation

NOTE: Unit sizes 350 and 400 with electronic modulation require a minimum natural gas supply pressure of 6 IN WC.

- Depending on heat requirements established by the thermistor sensor, the burner modulates up to 100% firing. The thermistor is a resistor that is temperature sensitive in that as the surrounding temperature changes, the resistance (ohms) changes through the thermistor. This change is monitored by the solid-state control center (amplifier), which provides a varying DC current to the modulating valve to adjust the gas input.
- Each modulating valve is basically a regulator with electrical means of raising and lowering discharge pressure. When no DC current is available to this device, it functions as a gas pressure regulator that supplies 3.5 IN WC pressure to the main operating valve.
- Refer to the wiring diagram provided with the furnace for proper wiring connections for the electronic modulation system.
- The type and capability of the electronic modulation system, depend on the option selected.

Electronic Modulation Between 50% and 100% Firing Rate (Option AG7, AG8, or AG9)

- Electronic modulation for heating that is controlled by a specially-designed room [thermostat](#) (60–85°F) is identified as option AG7.
- Electronic modulation for makeup air application that is controlled by a duct sensor and temperature selector (55–90°F) is identified as option AG8 or AG9. The temperature selector setting for option AG8 is on the amplifier (see [Figure 25](#)). Option AG9 has a remote temperature selector. Both systems are available with an [override thermostat](#).

CONTROLS—CONTINUED

Optional Electronic Modulation—Continued

Electronic Modulation Between 50% and 100% Firing Rate (Option AG7, AG8, or AG9)—Continued



AMPLIFIER

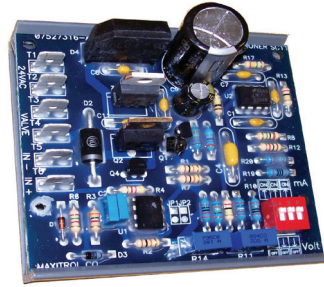

SIGNAL CONDITIONER

Figure 25. Maxitrol Amplifier and Signal Conditioner

Computer-Controlled Electronic Modulation Between 50% and 100% Firing Rate (Option AG21)

- With option AG21, the furnace is equipped with a Maxitrol signal conditioner (see [Figure 25](#)) that operates much the same way as the amplifier above to control the regulator valve. The signal conditioner accepts an input signal of either 4–20 milliamps or 0–10V from a customer-supplied control device such as a computer.
- With the dip switches on the conditioner positioned to ON, the conditioner accepts a 4–20 milliamp signal. With the dip switches on the conditioner positioned to OFF, the conditioner accepts a 0–10V signal. The conditioner converts the signal to the 0–20V DC current required to control the modulating valve.

Electronic Modulation Between 20–28% and 100% Firing Rate (Option AG39)

NOTE: Option AG39 (US Patent 6,109,255) is available only with natural gas and is not available on unit size 350.

- Depending on its size, a furnace equipped with option AG39 has a 20–28% turndown ratio. The furnace will ignite at any input rate in the available range and will maintain average thermal efficiencies equal to or greater than the thermal efficiency at full fire.
- The gas train (see [Figure 26](#)) includes a single-stage gas valve, a modulating valve, and two gas pressure switches. The burner rack is equipped with one flash carryover and a regulated gas lighter tube system. The carryover lighter tube receives its gas supply through the regulator simultaneously with the gas to the burner. Control of the system is through a Maxitrol amplifier (see [Figure 25](#)) with a corresponding remote temperature dial.

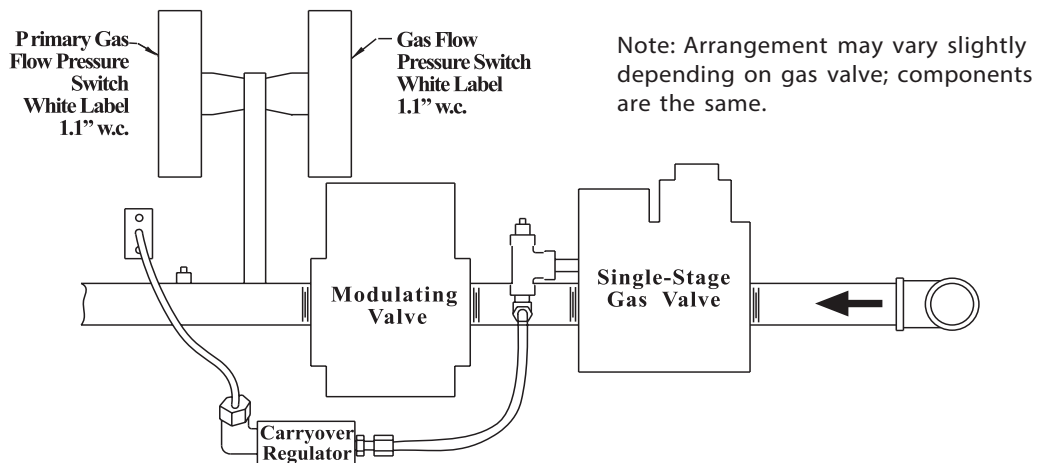

Figure 26. Option AG39 Manifold Arrangement

- The gas supply (refer to pressure requirements in [Table 18](#)) connects to the single-stage gas valve. To compensate for additional pressure loss through the modulating valve, the single-stage gas valve has a custom outlet pressure setting higher than when it is used on a standard gas manifold. The pilot tubing connects to the pilot port on the single-stage gas valve.
- When the valve receives a call for heat from the amplifier and pilot is established, gas flow from the single-stage valve goes to both the modulating valve and the regulated lighter tube system. When the signal from the amplifier to the modulating valve requires less-than-high fire operation, the modulating valve functions to lessen the gas flow to the burner to reduce the input rate to that which is necessary to maintain the desired temperature. When the input rate is reduced enough to decrease the gas pressure to 1.1 IN WC, the primary gas pressure switch in the manifold activates the gear motor that controls the bypass damper in the venter/combustion air system. The bypass damper opens to divert some of the incoming air directly into the flue duct to reduce air flow through the burner. Safety switches monitor the position of the bypass damper. When the gas pressure rises to >1.1 IN WC, the bypass damper closes.
- **Sensor location:** For the convenience of the installer, the duct temperature sensor is factory-installed in the cabinet leg (see [Figure 24](#)). Although the sensor has a mixing tube, at this distance from the discharge it does not receive a true mix, so the temperature read by the sensor will be slightly higher than the actual air entering the ductwork. The system will provide comfort level heat if the selector is set slightly higher to compensate for this reading. If a direct correlation of these two temperatures is required, move the duct sensor to a location in the ductwork about 10–12 feet (3–3.7 meters) from the furnace discharge.
- This uniquely-designed modulation system requires combustion air pressure settings different from the standard system. Refer to [Table 17](#) for the approximate combustion air proving switch settings at sea-level operation.

Electronic Modulation Between 20–28% and 100% Firing Rate (Option AG40)

NOTE: Option AG40 (US Patent 6,109,255) is available only with natural gas and is not available on unit size 350.

- With option AG40, the furnace is equipped with a Maxitrol signal conditioner (see [Figure 25](#)) that receives an input signal of either 4–20 milliamps or 0–10V from a customer-supplied control device such as a computer. With the dip switches on the conditioner positioned to ON, the conditioner accepts a 4–20 milliamp signal. With the dip switches on the conditioner positioned to OFF, the conditioner accepts a 0–10V signal. The conditioner converts the signal to the 0–20V DC current required to control the modulating valve. The heater functions and is equipped in the same way as option AG39 except that with computer control, the temperatures are selected through the software and there is no temperature selector or duct sensor.
- Refer to [Table 18](#) for option AG40 pressure requirements and to [Figure 27](#) for troubleshooting option AG40.
- This uniquely-designed modulation system requires combustion air pressure settings different from the standard system. Refer to [Table 17](#) for the approximate combustion air proving switch settings at sea-level operation.

Table 18. Options AG39 and AG40 Pressure Requirements

Unit Size	Maximum Turndown (%)	Input Range (MBH)	Factory-Set Inlet Pressure to Modulating Valve (IN WC)	Required Gas Supply Pressure (IN WC)
125	20	25–125	3.9	5.0
150	27	40.3–150	3.7	5.0
175	23	40.3–175	3.7	5.0
200	26	51.8–200	3.9	5.0
225	23	51.8–225	3.9	5.0
250	28	69–250	4.0	5.0
300	23	69–300	4.0	5.0
400	25	100–400	4.4	6.0

CONTROLS—CONTINUED

Optional Electronic Modulation—Continued

Electronic Modulation Between 20–28% and 100% Firing Rate (Option AG40)—Continued

General Instructions: For each step, check to ensure that the wiring is not defective and that the wiring connections are secure.

Symptom - Part 1:

Main burners are inoperative. Assumes that 24 volts is available between Terminal 2 and Terminal 7.

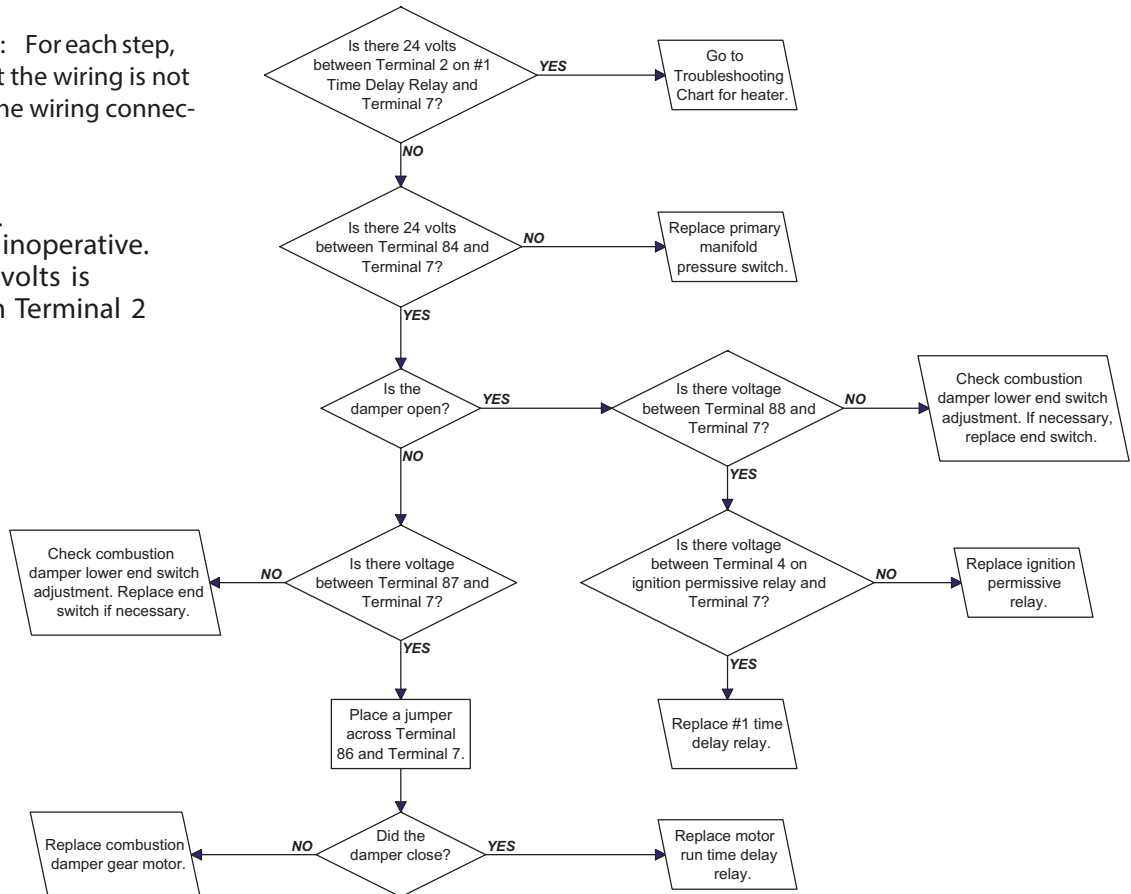

Symptom - Part 2:

Steady call for heat - burner cycles.

Assumes that 24 volts is available between Terminals 11 and 7 and Terminals 2 and 7.

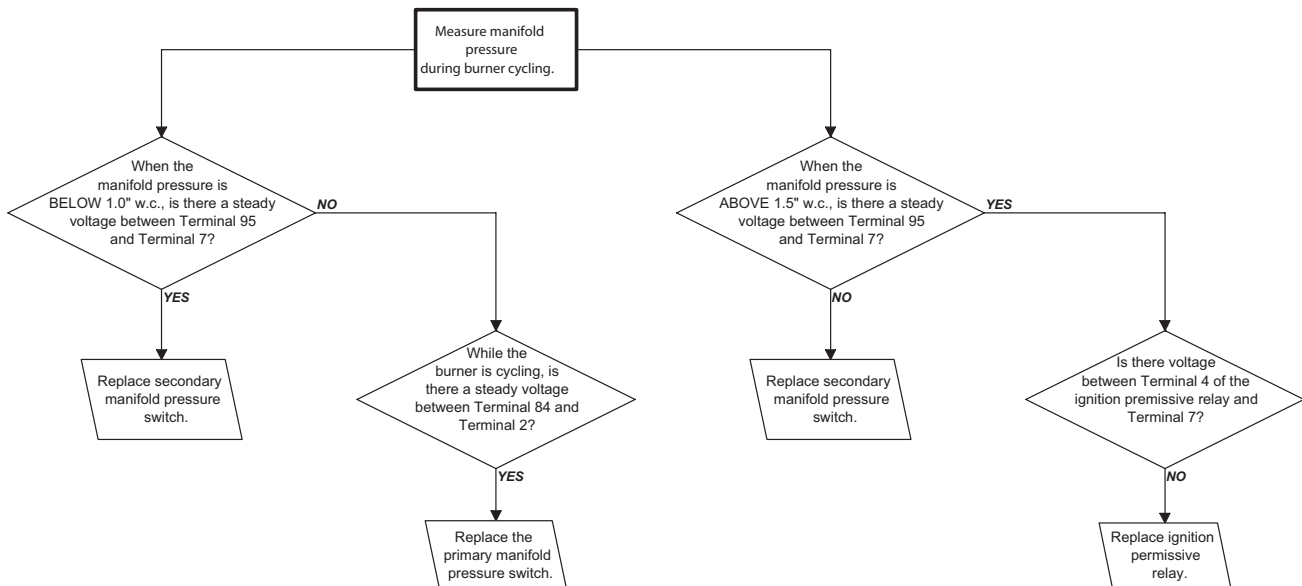

Figure 27. Troubleshooting Guide for Checking Bypass Combustion Air Damper Safety Circuit on Units with Option AG39 or AG40

Pilot and Ignition Systems

⚠ WARNING ⚠

Due to high voltage on the pilot spark wire and pilot electrode, do not touch when energized.

- **Pilot:** All pilots are vertical, target-type with a lint-free feature. Pilot flame should be approximately 1-1/4 inches in length. Pilot gas pressure should be the same as the supply line pressure. Pilot gas is supplied through the combination valve. Pilot gas flow is controlled by an adjustment screw located in the valve body. For maintenance, refer to [Burner Rack Maintenance](#) and [Cleaning Pilot and Burners](#) sections.
- **Ignition system:** Natural gas units are equipped with a spark-ignited intermittent safety pilot system that shuts off the pilot gas flow between heat cycles. Propane units (or as an option on natural gas units) require a lockout device that stops the gas flow to the pilot if the pilot fails to light in 120 seconds. The lockout device has a 1-hour retry or can be manually reset by interruption of the [thermostat](#) circuit. Refer to the wiring diagram provided with the unit for pilot system identification and proper wiring. Pilot with lockout is option AH3. Spark pilot without lockout is option AH2.
- **Ignition controller:** As part of the intermittent safety pilot system, the ignition controller provides high voltage spark to ignite pilot gas and also acts as the flame safety device. After ignition of the pilot gas, the ignition controller electronically senses the pilot flame. A low voltage DC electrical signal is imposed on the separate metal probe in the pilot assembly. The metal probe is electrically insulated from ground. The pilot flame acts as a conduction path to ground to complete the DC circuit and prove pilot flame. Proper operation of the electronic spark ignition system requires a minimum flame signal of 0.2 microamps, as measured by a microammeter. With pilot flame proven, the ignition controller energizes the main gas valve.

Burners, Burner Orifices, and Carryover System

NOTE: Natural gas units have a dual flash carryover system and do not require a carryover orifice.

- **Burners:** Individually-formed steel burners capable of operating on either natural or propane gas are used in this heater. These burners have accurate, machine-formed ports to provide controlled flame stability and operation without lifting or flashback. All burners are lightweight and are factory-mounted in an assembly that permits all of the burners to be removed as a unit for inspection or service.
- **Burner orifices:** Heaters are shipped with burner orifices of proper size and type for the specified gas. Refer to [Table 19](#) for burner and carryover orifice specifications.

Table 19. Burner and Carryover Orifice Specifications

Unit Size	Burner Orifice						Carryover Orifice	
	Quantity	Natural Gas		Propane Gas		Propane Gas		
		PN	Drill Size	PN	Drill Size	PN	Drill Size	
125	5	84437	#42	61652	1.45 mm	9870	#70	
150	7	11833	#44	11830	#55	9680	#65	
175	7	84437	#42	61652	1.45 mm	9680	#65	
200	9	11828	#43	11830	#55	9680	#65	
225	9	84437	#42	61652	1.45 mm	9680	#65	
250	12	11833	#44	11830	#55	10370	#59	
300	12	84437	#42	61652	1.45 mm	10370	#59	
350	14	84437	#42	61652	1.45 mm	9791	#56	
400	16	84437	#42	61652	1.45 mm	9791	#56	

- **Burner Carryover Systems:** All natural gas burners, except when equipped with electronic modulation option AG39 or AG40, are equipped with two flash carryover systems—one on each end of the burner rack.

CONTROLS—CONTINUED

Burners, Burner Orifices, and Carryover System—Continued

NOTE: Natural gas burner racks on furnaces manufactured *before* series 6 units have a gas lighter tube carryover and one flash carryover. All propane gas burners are equipped with one flash carryover and a regulated gas tube system. The carryover lighter tube receives its gas supply through a regulator simultaneously with the gas to the burner orifices.

- During regular service, check the main burner ports, the carryover assemblies, and the orifices for cleanliness.
- Typical natural gas and propane gas burner racks are shown in [Figure 28](#).

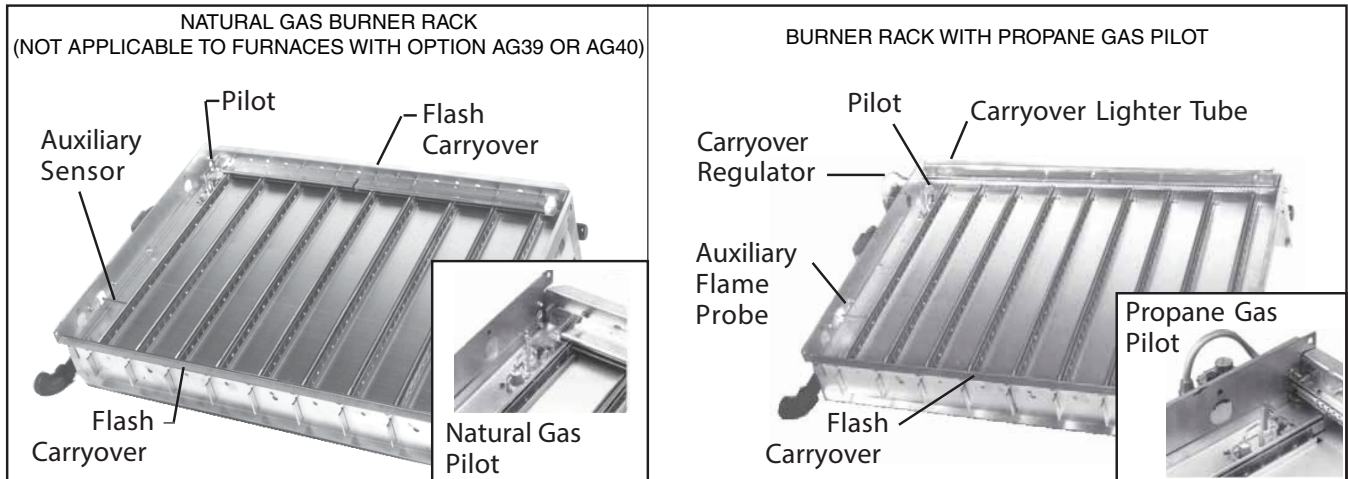
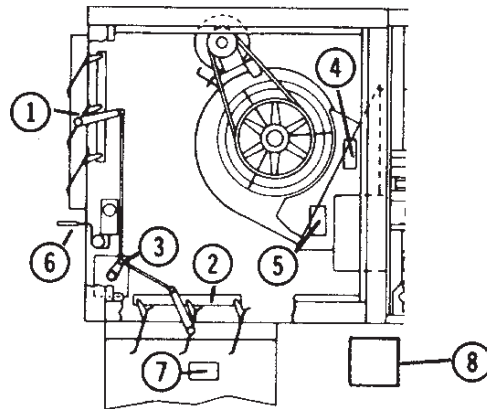

Figure 28. Typical Burner Rack

Dampers and Damper Controls

For information on damper control options (see [Figure 29](#)), refer to the wiring diagram provided with the unit. To adjust dampers, refer to the [Damper Linkage Adjustment](#) section.



- | | |
|------------------------|--------------------------|
| (1) Outside Air Damper | (5) Potentiometer |
| (2) Return Air Damper | (6) Mixed Air Controller |
| (3) Damper Motor | (7) Warmup Control |
| (4) Potentiometer | (8) Remote Potentiometer |

Figure 29. Typical Damper Controls

Dirty Filter Switch

The optional dirty filter pressure switch is used to provide warning to the user by energizing an indicator light on an optional remote console. The light indicates that the filters are in need of cleaning or changing. The adjustable, single-pole/normally-open differential switch closes when an increase in pressure differential above the setpoint, is sensed across the filter bank. The dirty filter switch is located in the furnace section. To adjust the dirty filter switch, refer to the [Dirty Filter Switch Adjustment](#) section.

OPERATION

⚠ WARNING ⚠

To ensure safety, follow the lighting instructions located on the outlet box cover.

Pre-Startup Checklist

• Installation checks:

- Verify suspension/mounting methods and clearances (refer to [Suspension](#), [Mounting](#), and [Clearances](#) sections)
- Verify that bolts removed from shipping clips have been returned to heater cabinet (refer to [Uncrating/Unpacking](#) section)
- Check duct connections (refer to [Duct Connections](#) section)
- Check venting (refer to [Venting/Combustion Air Connections](#) section) and ensure that flue discharge and combustion air openings are free of obstructions
- Ensure that electrical entrance and gas supply pipe openings are sealed
- Ensure that all condensate drains are open (refer to [Condensate Drain Installation](#) section)

• Electrical checks:

- Ensure that electrical supply is in accordance with voltage rating on unit's rating plate
- Ensure that all field wiring is in accordance with wiring diagram and that wire gauges are as required for electrical load
- Ensure that fuses or circuit breakers are in place and are sized correctly

• Gas supply checks:

- Check piping for leaks and proper gas line pressure and bleed trapped air from gas lines (refer to [Supply Piping Connections](#) section)
 - a. Turn OFF manual shutoff valve.
 - b. Turn ON gas supply.
 - c. Observe gas meter for movement or attach pressure gauge readable to 0.1 IN WC and, after turning gas ON for 10 seconds, turn OFF gas supply—no change in pressure should occur over 3-minute period.
 - d. If step c indicates leak, locate leak by brushing soapy solution on all fittings—bubbles will appear at any leaks.
 - e. Repair any leaks and repeat test.

• Blower checks:

- Check blower pulley and motor pulley to ensure that they are secure to shafts and check belt tension and alignment (refer to [Checking and Adjusting Belt Tension](#) section)
- Check blower rotation (refer to [Reversing Blower Rotation](#) section)
- Verify removal of all shipping supports (refer to [Uncrating/Unpacking](#) section)
- Check damper linkage (refer to [Damper Linkage Adjustment](#) section)

OPERATION—CONTINUED

Startup

1. Close all panels tightly.
2. Turn ON electric and gas supply to furnace.
3. Adjust [thermostat](#) or ductstat so that call for heat exists.
4. Observe for complete sequencing of safety pilot and ignition (refer to [Table 20](#)).

NOTE: On units equipped with a controller that includes lockout control, if the pilot is not established within 120 seconds (approximately), the unit locks out for 1 hour or must be reset by interrupting the power to the control circuit (refer to lighting instructions on unit).

Table 20. Sequence of Operation

Step	Action	Observe
1	Set thermostat at its lowest setting	
2	Turn ON electric and gas supply to furnace	
3	Turn ON manual gas valves	
4	Set thermostat at desired setting— thermostat calls for heat	Venter motor is energized after 15-second (approximate) time delay
		Venter flow switches from NC to NO contacts to energize pilot gas valve and spark gap to produce pilot flame on each operating cycle
		Sensing probe proves presence of pilot flame and energizes safety switch portion of control to deenergize spark gap and energize main valve
		Main gas ignites and unit fires at full rate
	If flame is extinguished during main burner operation, safety switch closes main valve and recycles spark gap	Blower motor operates from fan time delay
		Thermostat is satisfied
		Solenoid gas valve is deenergized
		Pilot gas valve is deenergized
		Ignition controller is deenergized
		Time delay relay keeps venter motor on for approximately 1 minute (post-purge)
5	To shut down, set thermostat to lowest setting	Blower motor remains on as determined by fan time delay

Post-Startup Checklist

- Observe burner flame at full fire. Natural gas flame should be about 1-1/2 inches in height with blue coloring. Propane gas flame should be approximately same height with blue coloring. Yellow tipping may appear on propane gas. If yellow extends beyond 1/2- to 3/4-inch, adjust air shutters (refer to [Burner Air Shutter Adjustment](#) section). If shutter adjustment does not reduce yellowing, check for gas leaks at control manifold or orifice fitting.
- Turn unit OFF and ON, pausing 2 minutes between each cycle. Observe to verify smooth ignition. On two-stage or modulating burner systems, manipulate temperature adjustment slowly up and down to see if control is sequencing or modulating properly. Raising temperature setting drives burner on or to full fire.
- Using manometer or slant gauge readable up to 14 IN WC, check orifice manifold for operating pressure on full fire. Natural gas should be 3.5 IN WC at this point. Propane gas should be 10 IN WC at this point. Variations from these pressures are not recommended as ignition and efficiency performance can be adversely affected by improper pressure adjustment (refer to [Measure and Adjust Manifold \(Outlet\) Gas Pressure](#) section).
- If system is equipped with optional dirty filter switch, refer to [Dirty Filter Switch Adjustment](#) section for instructions to set switch.
- Place owner's envelope containing Limited Warranty Card, this manual, and any optional information in accessible location near heater. Follow instructions on envelope.

⚠ DANGER ⚠

- The gas burner in this gas-fired equipment is designed and equipped to provide safe, controlled, complete combustion. However, if the installation does not permit the burner to receive the proper supply of combustion air, complete combustion may not occur. The result is incomplete combustion, which produces carbon monoxide, a poisonous gas that can cause death.
- Safe operation of separated-combustion, indirect-fired gas burning equipment requires a sealed, properly-operating vent system that vents all flue products to the outside atmosphere. **FAILURE TO PROVIDE PROPER VENTING WILL RESULT IN A HEALTH HAZARD THAT COULD CAUSE SERIOUS PERSONAL INJURY OR DEATH.**
- Install either the horizontal (see [Figure 19](#)) or vertical (see [Figure 13](#)) combustion air/vent system using the concentric adapter provided. Always comply with the combustion air requirements in the installation codes and instructions.
- Combustion air at the burner should be regulated only by manufacturer-provided equipment. **NEVER RESTRICT OR OTHERWISE ALTER THE SUPPLY OF COMBUSTION AIR TO ANY HEATER. CHECK THE COMBUSTION AIR/VENT SYSTEM FOR SOUNDNESS AND FUNCTION AND MAINTAIN IT IN PROPER OPERATING CONDITION.**

ADJUSTMENTS

Belts, Blowers, and Drives

Checking and Adjusting Belt Tension

- Proper belt tension is important to the long life of the belt and motor. A loose belt will cause wear and slippage. Too much tension will cause excessive motor and blower bearing wear. Check belt tension as shown in [Figure 30](#).
- If the belt cannot be depressed 3/4 inches (19 mm), as shown in [Figure 30](#), adjust the belt tension as follows:
 - a. Ensure that belt is aligned in pulley grooves properly and is not angled from pulley to pulley.
 - b. Loosen adjusting screw locknut on motor base and turn adjusting screw until belt can be depressed 3/4 inches (19 mm).
 - c. When correct belt tension is achieved, retighten adjusting screw locknut.

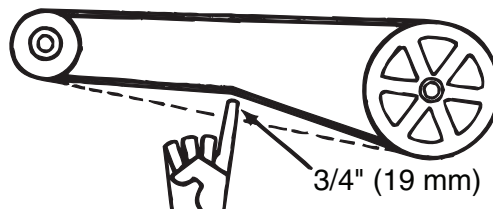

Figure 30. Checking Belt Tension

Adjusting Blower Speed

- Blower speed may be adjusted to achieve the desired outlet temperature as long as the adjustment is within the temperature rise and static pressure limits shown on the furnace rating plate. Motors are factory-set between maximum and minimum blower speeds.
- If the duct resistance is low, the blower may deliver too high an air volume. If the resistance is very low, the blower may deliver excess air to overload the motor, causing the overload protector to cycle the motor. Reducing the blower speed will correct these conditions. If ductwork is added to an installation, it may be necessary to increase the blower speed. Decreasing blower speed increases outlet temperature. Increasing blower speed decreases outlet temperature.

ADJUSTMENTS—CONTINUED

Belts, Blowers, and Drives—Continued

Adjusting Blower Speed—Continued

- At final adjustment, amperes should not exceed motor nameplate amp rating. The installation must be adjusted to obtain a temperature rise within the range specified on the furnace rating plate.
- The belt drive on these units is equipped with an adjustable pulley that permits blower speed adjustment. Adjust the blower speed as follows:
 - a. Shut OFF gas and electric power.
 - b. Loosen belt tension and remove belt.
 - c. Loosen setscrew on side of pulley away from motor.
 - d. To increase blower speed and decrease outlet temperature, turn adjustable half of pulley inward. To decrease blower speed and increase outlet temperature, turn adjustable half of pulley outward. One turn of pulley changes speed 8–10%.
 - e. Tighten setscrew on flat portion of pulley shaft.
 - f. Replace belt and adjust belt tension in accordance with [Checking and Adjusting Belt Tension](#) section.
 - g. Turn on gas and electric power and light heater in accordance with instructions on lighting instruction plate.
 - h. Check motor amps using ammeter (maximum motor amp rating on motor nameplate must not be exceeded).
 - i. When adjustment is complete, check for proper operation.

Reversing Blower Rotation

Each blower housing is marked for proper rotation. Rotation may be changed on single-phase motors by rewiring in the motor terminal box. Rotation may be changed on three-phase motors by interchanging two wires on the three-phase supply connections.

Motor Load and Amp Adjustment

- Amps may be adjusted downward by reducing blower rpm or by increasing duct system static pressure. Use an ammeter to check blower motor amps.
- See the motor rating plate for exact motor specifications. Do not exceed the amp rating on the motor nameplate.
- Venter motor amps are 1.5 amps for a 115V or 575V unit or 0.8 amps for a 208V, 230V, or 460V unit.
- [Table 21](#), which lists the Full Load Amps (FLA) of blower motors (open) based on Horsepower (HP) and Voltage (V), can be used for sizing line wiring but should not be interpreted as the exact motor amps.

Table 21. FLA of Blower Motors (Open, Single-Speed, Average Values)									
Voltage/Phase	HP								
	1/4	1/3	1/2	3/4	1	1-1/2	2	3	5
	FLA								
115V/1PH	4.60	5.60	8.80	11.00	13.00	18.20	20.40	24.80	—
208V/1PH	2.50	3.10	5.10	6.10	7.20	10.10	11.30	13.70	28.00
230V/1PH	2.30	2.80	4.40	5.50	6.50	9.10	10.20	12.40	26.00
208V/3PH	1.70	1.80	2.20	2.90	3.60	5.80	7.30	9.30	14.60
230V/3PH	1.50	1.60	2.00	2.60	3.20	5.20	6.60	8.40	13.20
460V/3PH	0.75	0.80	1.00	1.30	1.60	2.60	3.30	4.20	6.60
575V/3PH	—	—	—	—	1.30	2.10	2.60	3.40	5.30

Measure and Adjust Manifold (Outlet) Gas Pressure

Measuring manifold gas pressure cannot be done until the heater is in operation (refer to **OPERATION** section).

- **For natural gas:** When the heater leaves the factory, the combination valve is set so that the outlet gas pressure of a single-stage valve or high fire of a two-stage valve is regulated to 3.5 IN WC. Low fire on a two-stage valve is set to 1.8 IN WC. Inlet supply pressure to the valve must be a minimum of 5 IN WC or as noted on the rating plate and a maximum of 14 IN WC.

NOTE: Always check the rating plate for minimum gas supply pressure.

- **Minimum natural gas supply pressure:** Requirements vary based on size of burner and the gas control option. Most units require a minimum of 5 IN WC natural gas as stated above, but sizes 350 and 400 with electronic modulation require a minimum of 6 IN WC natural gas supply pressure.
- **For propane gas:** When the heater leaves the factory, the combination valve is set so that the outlet gas pressure of a single-stage valve or high fire of a two-stage valve is 10 IN WC. Low fire on a two-stage valve is set to 5 IN WC. Inlet pressure to the valve must be a minimum of 11 IN WC and a maximum of 14 IN WC.

WARNING

- **Manifold gas pressure must never exceed 3.5 IN WC for natural gas or 10 IN WC for propane gas.**
 - **Before attempting to measure or adjust manifold gas pressure, the inlet (supply) pressure must be within the specified range for the gas being used, both when the heater is in operation and when it is on standby. Incorrect inlet pressure could cause excessive manifold gas pressure immediately or at some future time.**
-

NOTE: A manometer (fluid-filled gauge) is recommended rather than a spring-type gauge due to the difficulty of maintaining calibration of a spring-type gauge.

1. With the manual valve (on the combination valve) positioned to prevent flow to the main burners, connect a manometer to the 1/8-inch pipe outlet pressure tap in the valve.
 2. Open the valve and operate the heater. Measure the gas pressure to the manifold. To measure the low-stage pressure on units equipped with a two-stage valve, disconnect the wire from the HI terminal on the valve. Be sure to reconnect the wire.
-

CAUTION

DO NOT bottom out the gas valve regulator screw. This can result in excessive overfire and heat exchanger failure due to unregulated manifold pressure.

3. Normally, adjustments to the factory-preset regulator should not be necessary. If adjustment is necessary, set pressure to correct settings by turning the regulator screw IN (clockwise) to increase pressure or OUT (counterclockwise) to decrease pressure. Consult the valve manufacturer's literature provided with the furnace for more detailed information.

ADJUSTMENTS—CONTINUED

Measure and Adjust Manifold (Outlet) Gas Pressure—Continued

High Elevation (>2,000 Feet/609 Meters) Installations

NOTES:

- **High elevation (>2,000 feet/609 meters) application with this unit depends on the installation elevation and the heating value of the gas. At high elevations, the heating value of natural gas is always lower than the heating value at sea level.**
 - **Deration is necessary to compensate for low atmospheric pressure at high elevations. Generally this will require obtaining the gas heating value from the local gas utility and replacing the burner orifices.**
-

For high elevation (>2,000 feet/609 meters) installations that require orifice replacement, replace the burner orifices as follows:

1. Determine model number and rated input (BTUh) from unit's rating plate.
2. Determine appropriate orifice replacement (refer to [Table 22](#)) for installation elevation.
3. Unthread existing gas orifices from gas manifold.

⚠ DANGER ⚠

- **Do not use Teflon tape or pipe joint compound on the orifice threads. The hole in the orifice may become blocked and may cause fire, explosion, property damage, carbon monoxide poisoning, personal injury, or death.**
 - **Use only using factory-supplied orifices. Do not attempt to drill out orifices in the field. Improperly drilled orifices may cause fire, explosion, carbon monoxide poisoning, personal injury, or death.**
-
4. Thread replacement gas orifices into gas manifold. To prevent cross-threading, hand-tighten orifices into gas manifold until snug and then tighten one-half to one turn using wrench.

⚠ DANGER ⚠

DO NOT use an open flame to check for gas leaks.

5. Check all connections for gas leaks using commercial leak-detecting fluid or rich soap and water solution. Leaks are indicated by presence of bubbles. If leak is detected, tighten connection. If leak cannot be stopped by tightening connection, replace part(s).

Table 22. High Elevation Burner Orifices

Installation Elevation (Feet (Meters))	Installation Location	Unit Size	Natural Gas		Propane	
			PN	Orifice Size	PN	Orifice Size
2001–3000 (611–915)	US	100, 125, 175, 225, 300, 350, 400	84437	#42	11834	#54
		150, 250	38678	#45	11830	#55
		200	11833	#44	11830	#55
2001–4500 (611–1373)	Canada	100	84437	#42	11834	#54
		125, 175, 225, 300, 350, 400	11828	#43	11834	#54
		150, 250	38678	#45	11830	#55
3001–4000 (916–1220)	US	200	11833	#44	11830	#55
		100	84437	#42	11834	#54
		125, 175, 225, 300, 350, 400	11828	#43	11834	#54
4001–5000 (1221–1525)	US	150, 250	38678	#45	11830	#55
		200	11833	#44	11830	#55
		100	84437	#42	11834	#54
5001–6000 (1526–1830)	US	125, 175, 225, 300, 350, 400	11828	#43	11834	#54
		100	84437	#42	11834	#54
		150, 250	38678	#45	11830	#55
6001–7000 (1831–2135)	US	200	11833	#44	11830	#55
		100, 125, 175, 225, 300, 350, 400	11828	#43	97360	1.35 mm
		150, 250	38678	#45	39658	#56
7001–8000 (2136–2440)	US	200	11833	#44	11830	#55
		100	11828	#43	97360	1.35 mm
		125, 175, 225, 300, 350, 400	11833	#44	97360	1.35 mm
8001–9000 (2441–2745)	US	150, 250	84853	#47	39658	#56
		200	38678	#45	39658	#56
		100, 125, 175, 225, 300, 350, 400	11833	#44	11830	#55
9001–10,000 (2746–3045)	US	150, 250	16590	#46	39658	#56
		200	16590	#46	39658	#56
		100	11833	#44	11830	#55
		125, 175, 225, 300, 350, 400	38678	#45	11830	#55
		150, 250	40414	#48	39658	#56
		200	84853	#47	39658	#56

Conversion to LP (Propane)



Conversion to LP (propane) gas must be performed by qualified service personnel using a factory-supplied conversion kit. Failure to use the proper conversion kit can cause fire, explosion, property damage, carbon monoxide poisoning, personal injury, or death.

If LP (propane) conversion is required, convert the unit in accordance with form **OPT-GC** listed in **Table 1**. When conversion is complete, verify that the input rate is correct.

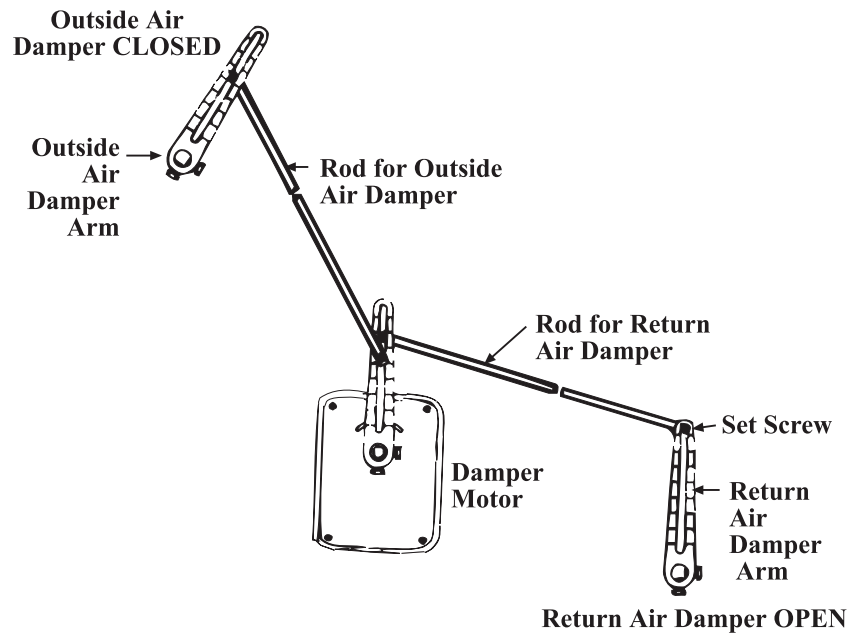

Figure 32. Damper Linkage

Dirty Filter Switch Adjustment

After the unit is started but before continuous operation, the dirty filter switch must be set as follows:

1. With clean filters in place, blower doors closed, and blower operating, decrease pressure setting by adjusting setscrew on switch (see [Figure 33](#)) clockwise until indicator light is energized or setscrew is bottomed out.
2. At that point, adjust setscrew three full turns counterclockwise or until setscrew is top-ended.
3. At that setpoint, indicator light will be activated at approximately 50% filter blockage.

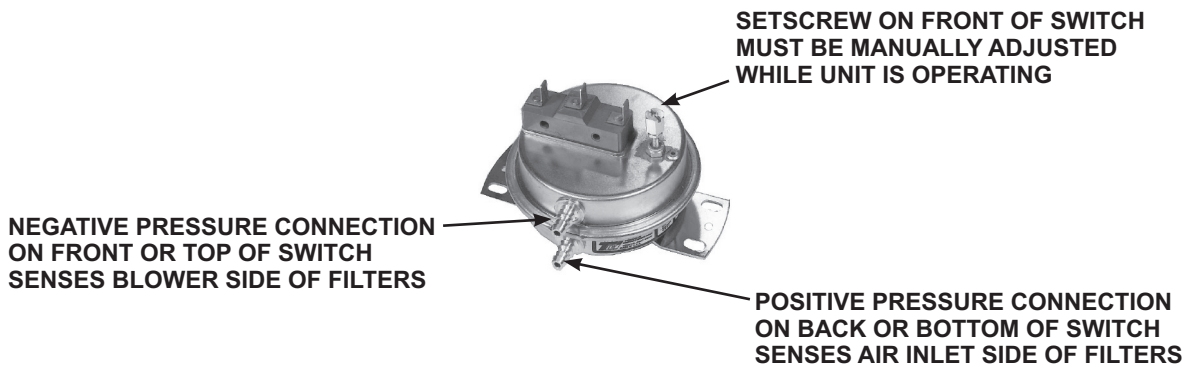

Figure 33. Dirty Filter Switch

MAINTENANCE

⚠ WARNING ⚠

If you turn OFF the power supply, turn OFF the gas.

NOTE: Use only factory-authorized replacement parts.

This unit will operate with a minimum of maintenance. To ensure long life and satisfactory performance, a furnace that is operating under normal conditions should be inspected every 4 months. If the furnace is operating in an area where an unusual amount of dust, soot, or other impurities are present in the air, more frequent inspection is recommended.

Service Checklist

The following section is designed to aid a qualified service person in maintaining and servicing this equipment. At a minimum, perform the following annually:

- Check gas valve to ensure that gas flow is being shut off completely
- Clean heat exchanger both internally and externally
- Check pilot burner and main burners for scale, dust, or lint accumulation and clean as needed
- Check vent/combustion air system, inspect all joints, and replace any parts that do not appear sound
- Check main burner ports, carryover assemblies, and orifices for cleanliness
- Check wiring for any damaged wire—replace damaged wiring (refer to [Electrical Connections](#) section for wiring requirements)

Maintenance Procedures

Combination Gas Valve Maintenance

⚠ WARNING ⚠

The combination gas valve is the prime safety shutoff. To ensure positive closure, all gas supply lines must be free of dirt or scale before connecting them to the unit.

Remove external dirt accumulation and check wiring connections. The combination gas valve must be checked annually as follows to ensure that the valve is completely shutting off gas flow.

1. Locate 1/8-inch FPT INLET pressure tap on combination gas valve (see [Figure 34](#)).

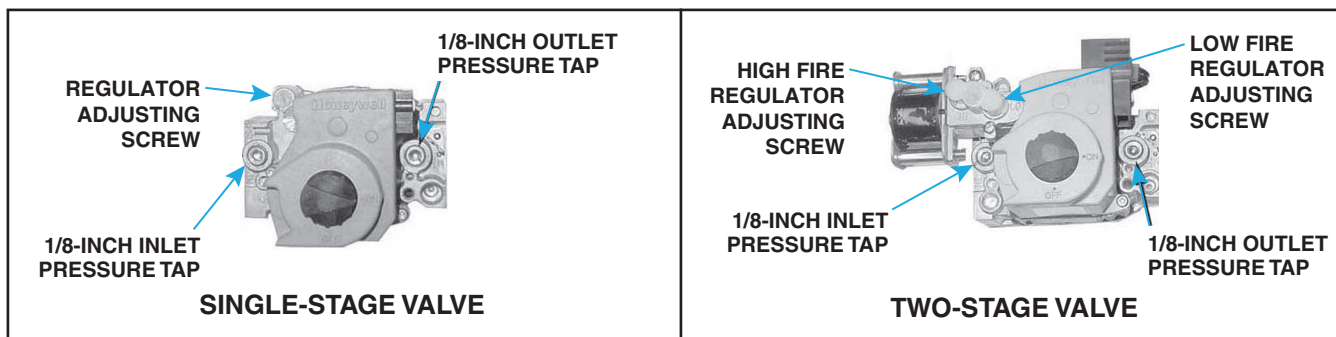

Figure 34. Combination Gas Valve Test Connections

NOTE: A manometer (fluid-filled gauge) with an inches water column scale is recommended.

2. With field-installed manual valve closed to prevent flow to gas valve, connect manometer to 1/8-inch FPT INLET pressure tap (see [Figure 34](#)).
3. With field-installed manual valve closed, turn up [thermostat](#) to fire unit and to allow unit to go through one trial for ignition.
4. Reset [thermostat](#) to shut OFF unit and observe manometer for 2 to 3 minutes for indication of gas pressure. No pressure should be indicated on manometer. If manometer indicates gas pressure, field-installed manual gas valve must be replaced or repaired before combination gas valve can be checked.
5. If manometer does not indicate gas pressure, slowly open field-installed manual gas valve. After manometer indicates that gas pressure has reached equilibrium, close manual shutoff valve.

NOTE: Refer to [Gas Supply Pressure](#) section for operational pressure settings and instructions for checking pressure settings.

6. Observe gas pressure on manometer. There should be no loss of gas pressure. If manometer indicates loss of gas pressure, replace combination gas valve before placing heater in operation.

Vent/Combustion Air System Maintenance

Check vent/combustion air system at least once a year. Inspect all joints, seams, and terminal caps. Clean grills and screens. Replace any defective parts.

Burner Rack Maintenance

Remove, disassemble, clean, reassemble, and re-install burner rack as follows:

1. Remove burner rack:
 - a. Turn OFF gas and electric supply.
 - b. Remove control access side panel.
 - c. Disconnect any pilot lines and flame sensor leads.
 - d. Mark and disconnect electric valve leads.
 - e. Uncouple union in gas supply.
 - f. Remove sheet metal screws in top corners of burner rack assembly.
 - g. Pull drawer-type burner rack out of furnace.
2. Disassemble burner rack:

NOTE: Natural gas burner racks manufactured *before* Series 6 may have a lighter tube carryover system. Break the lighter tube connection at the orifice and remove the supply tubing, the drip shield, and the lighter tube.

- a. For natural gas burner rack, remove flash carryover system from manifold end of burner rack.
- b. For propane gas burner rack:
 - (1) Break lighter tube connection at regulator and remove lighter tube orifice supply tubing.
 - (2) Remove retaining screws in drip shield and remove shield.
 - (3) Remove retaining screws and slide out lighter tube.
- c. Pull main burners horizontally away from injection opening and lift out.
- d. Remove manifold bracket screws and remove manifold.
- e. Remove burner orifices.
- f. Remove screws and lift out pilot burner.

MAINTENANCE—CONTINUED

Maintenance Procedures—Continued

Burner Rack Maintenance—Continued

3. Clean burner rack in accordance with instructions in [Cleaning Pilot and Burners](#) section.
4. Re-assemble and re-install burner rack by reversing above steps, being careful not to create any unsafe conditions.

Cleaning Pilot and Burners

⚠ WARNING ⚠

To prevent injury when cleaning pilot and burners, wearing eye protection is recommended.

⚠ CAUTION ⚠

To prevent damage to pilot orifice, do not ream the orifice.

If the pilot flame appears short and/or yellow, check the pilot orifice for blockage caused by lint or dust accumulation.

1. Remove the pilot orifice and clean it using compressed air.
2. Check and clean the aeration slot in the pilot burner.
3. Clean the metal sensing probe and the pilot hood with an emery cloth and wipe off the ceramic insulator.
4. Check the spark gap (see [Figure 35](#)), which should be maintained to 0.100 inch (2.5 mm).

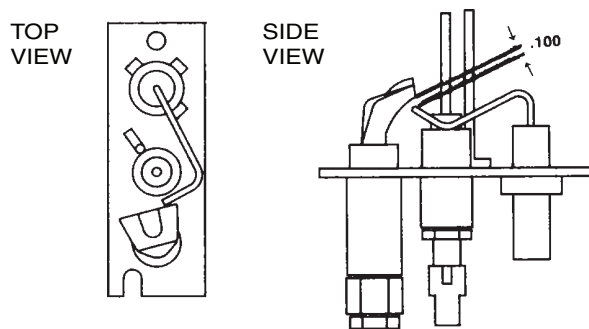

Figure 35. Pilot Assembly Spark Gap

5. After the pilot is cleaned, blow away any dirt using compressed air.
6. Clean the main burners and burner orifices using compressed air.

⚠ CAUTION ⚠

When cleaning burner ports, do not use anything that might change the port size.

7. Use an air nozzle to blow out scale and dust accumulation from the burner ports. Alternate blowing compressed air through the burner ports and then through the venturi. Use a fine wire to dislodge any stubborn particles from the burner ports.
8. Clean the burner rack carryover systems using compressed air.

⚠ WARNING ⚠

Due to high voltage on pilot spark wire and pilot electrode, do not touch when energized.

NOTE: When checking for spark with the pilot burner assembly removed from the burner rack, the pilot assembly must be grounded to the heater for proper spark.

1. If no spark occurs, check the following:
 - a. Using microammeter, measure voltage between terminals TH and 7 on ignition controller. Voltage should be at least 20V and no higher than 32V. Refer to **TROUBLESHOOTING** section if no voltage is observed.
 - b. Check for short to ground in high tension lead and/or ceramic insulator.
 - c. Verify that pilot spark gap (see **Figure 35**) is approximately 0.100 inch (2.5 mm).
 - d. If the above conditions are normal and no spark occurs, replace the ignition controller.

NOTE: If replacing an earlier model of ignition controller (see **Figure 36), order a replacement kit (PN **257472** for a unit with recycling gas control option AH2 or PN **257473** for a unit with gas control with lockout option AH3). Option codes are listed on the unit wiring diagram.**



RECYCLING IGNITION CONTROLLER FOR GAS CONTROL OPTION AH2, UTEC MODEL 1003-638A (PN **257009**): REPLACE WITH REPLACEMENT KIT (PN **257472**)



IGNITION CONTROLLER WITH LOCKOUT FOR GAS CONTROL OPTION AH3, UTEC MODEL 1003-514 (PN **257010**): REPLACE WITH REPLACEMENT KIT (PN **257473**)

Figure 36. Obsolete Ignition Controllers

2. If the main gas valve fails to open with a normal full-size pilot flame established, check the following:
 - a. If voltage between black and brown leads on main gas valve is 20–32 VAC and there is no main gas flow with built-in manual valve in FULL OPEN position, main valve is defective.
 - b. If there is no voltage between black and brown leads on main gas valve, check for disconnected or shorted flame sensor lead or flame sensor probe.
3. If the above conditions are normal and main gas flow is still off, the ignition controller is probably defective. Do not attempt to service the ignition controller as it does not contain any replaceable components.

MAINTENANCE—CONTINUED

Maintenance Procedures—Continued

Cleaning Heat Exchanger

1. Remove the burner rack assembly in accordance with [Burner Rack Maintenance](#) section to allow access to the inside of the heat exchanger tubes.
2. Use mirror and flashlight to examine narrow section of each tube.
3. Use 1/2-inch diameter furnace brush to scrub tube walls.
4. Use brush and/or air hose (18-to 24-inch) to remove any accumulated dust, rust, and/or soot.
5. Re-assemble furnace and check for proper operation.

Venter Motor Maintenance

Power venter motors are permanently lubricated. No oiling is required.

Air Circulation System Maintenance

Check blower pulley and motor pulley to ensure that they are secured to the shaft. Check belt condition and belt tension (refer to [Checking and Adjusting Belt Tension](#) section).

TROUBLESHOOTING

NOTE: If the furnace is equipped with electronic modulation option AG39 or AG40, see [Figure 27](#) for additional troubleshooting guidelines.

Refer to [Table 23](#) to troubleshoot the unit.

Table 23. General Troubleshooting

Symptom	Probable Cause	Remedy	
A. Venter motor will not start	1. No power to furnace	Turn ON power and check supply fuses or circuit breaker	
	2. No 24V power to venter relay	Turn up thermostat and check control transformer output	
		Check for loose or improper wire connections	
	3. Defective venter relay	Replace defective part	
4. Defective motor or capacitor	Replace defective part		
B. Pilot will not light with venter operating	1. Manual valve not open	Open manual valve	
	2. Air in gas line	Bleed gas line	
	3. Dirt in pilot orifice	Remove pilot orifice and clean with compressed air or solvent	
	4. Gas pressure too high or too low	Adjust gas pressure (refer to Measure and Adjust Manifold (Outlet) Gas Pressure section)	
	5. Kinked pilot tubing	Replace tubing	
	6. Pilot valve does not open	If 24V power is available at valve, replace valve	
	7. No spark		
	a. Loose wire connections	Ensure that all wires connections are solid	
	b. Transformer failure	Ensure that 24V power is available	
	c. Incorrect spark gap	Maintain spark gap at 0.100 inch	
	d. Spark cable shorted to ground	Replace worn or grounded spark cable	
	e. Spark electrode shorted to ground	Replace pilot if ceramic spark electrode is cracked or grounded	
	f. Drafts affecting pilot	Ensure that all panels are in place and are tightly secured to prevent drafts at pilot	
	g. Ignition control not grounded	Ensure that ignition control is grounded to furnace chassis	
	h. Faulty ignition controller	If 24V power is available to ignition controller and all other causes have been eliminated, replace ignition control	
	8. Optional lockout device interrupting control circuit due to above causes	Reset lockout by interrupting control at thermostat	
	9. Faulty combustion air proving switch	Replace combustion air proving switch	
	C. Pilot lights but main valve will not open	1. Manual valve not open	Open manual valve
		2. Main valve not operating	If 24V power is available at valve connections and valve remains closed, replace valve
Check and tighten all wiring connections			
3. Ignition control does not power main valve		Check and tighten all wiring connections	
		Ensure that flame sensor lead is not grounded and that insulation or ceramic is not cracked; replace as required	
c. Incorrect gas pressure		Adjust gas pressure (refer to Measure and Adjust Manifold (Outlet) Gas Pressure section)	
d. Cracked ceramic at sensor		Replace sensor	
e. Faulty ignition controller		If all checks listed in Spark Ignition System Maintenance section indicate no other cause, replace ignition controller (do not attempt to repair ignition controller, which has no field-replaceable parts)	

TROUBLESHOOTING—CONTINUED

Table 23. General Troubleshooting—Continued		
Symptom	Probable Cause	Remedy
D. Insufficient heat with heater operating	1. Dirty filters in blower system	Clean or replace filters
	2. Incorrect manifold pressure	Check manifold pressure (refer to Measure and Adjust Manifold (Outlet) Gas Pressure section)
	3. Limit control cycling on	Check air throughput
	4. Improper thermostat location or adjustment	Refer to thermostat manufacturer's instructions
	5. Belt slipping on blower	Adjust belt tension (refer to Checking and Adjusting Belt Tension section)
	6. Fan control improperly wired	Ensure that wiring connections are in accordance with wiring diagram
	7. Defective fan control	Replace fan control
	8. Blower set for too low temperature rise	Decrease blower speed (refer to Adjusting Blower Speed section) or increase static pressure
E. Motor will not run	1. Circuit open	Check wiring and connections
	2. Inoperative fan control	Replace fan control
	3. Fan control improperly wired	Ensure that wiring connections are in accordance with wiring diagram
	4. Inoperative contactor	Replace contactor
	5. Defective motor	Replace motor
F. Motor turns on and off while burner is operating	1. Motor overload device cycling	Verify motor load against motor rating plate Replace motor or overload device
	2. Three-phase motor rotating in opposite direction	Interchange two legs of supply connections
G. Motor cuts out on overload	1. Improper motor pulley adjustment	Ensure that motor pulley is properly-adjusted (refer to Adjusting Blower Speed section)
	2. Improper static pressure on duct system	Adjust dampers in duct system
	3. Low voltage	Check power supply

NOTES

INSTALLATION RECORD (TO BE COMPLETED BY INSTALLER)

Installer:

Name _____
Company _____
Address _____

Phone _____

Distributor (company from which the unit was purchased):

Company _____
Contact _____
Address _____

Phone _____

Model _____ **Serial No.** _____ **Date of Installation** _____

Specific installation notes (i.e., location, amps, gas pressure, temperature, voltage, adjustments, warranty, etc.):

BUILDING OWNER OR MAINTENANCE PERSONNEL:

For service or repair:

Contact the Installer listed above.

If you need additional assistance, contact the Distributor listed above.

For more information, contact your Factory Representative.

