

OVEN WIRING

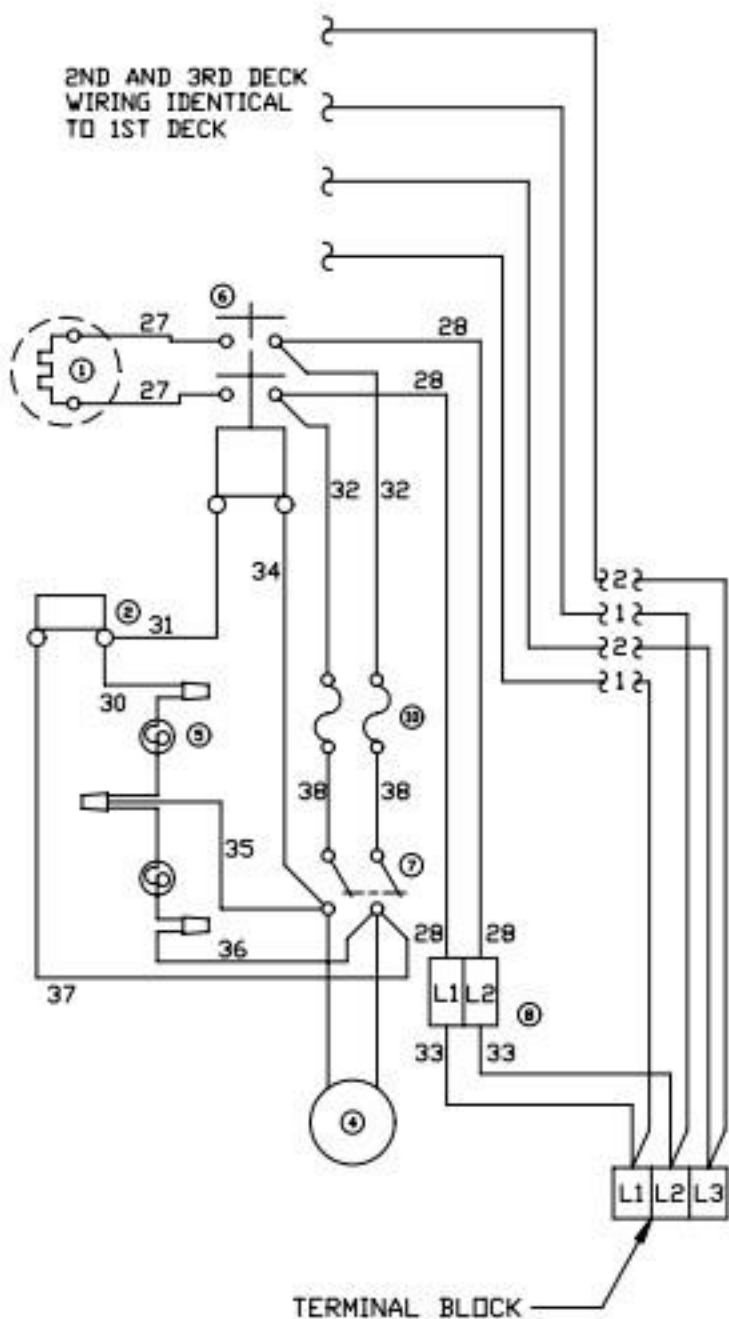

TERMINAL BLOCK

MODEL DESIGNATION

TOP ARRANGEMENT

MODEL DESIGNATION	TOP ARRANGEMENT		
	SEC-1	SEC-2	SEC-3
RF219-A	A	A	C
RF219-C	B	B	B
RF219-D	B	B	C
RF219-G	A	A	A
RF219-H	C	C	C

- ① HEAT ELEMENT
- ② THERMOSTAT
- ③ 6 HEAT SWITCH
- ④ MOTOR
- ⑤ PILOT LAMP
- ⑥ CONTACTOR
- ⑦ POWER SWITCH
- ⑧ CIRCUIT BREAKER
- ⑨ SPEED UNIT
- ⑩ FUSE

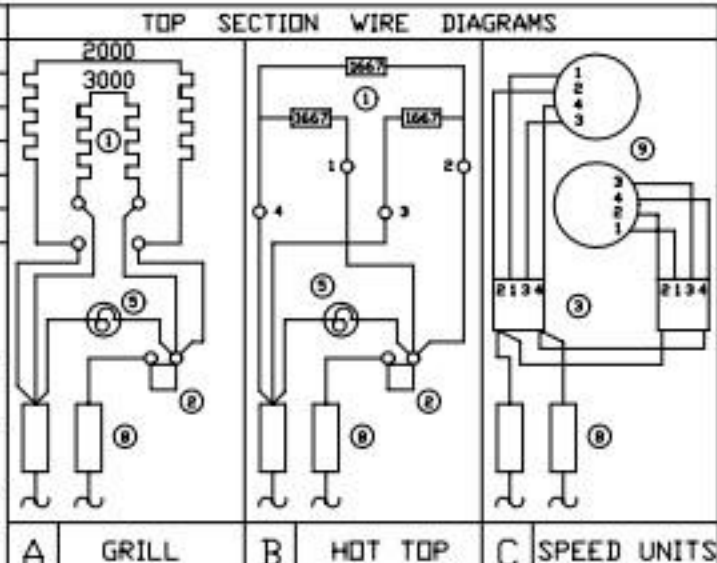

CONNECT WIRES FROM RANGE TOP OR ADDITIONAL DECKS TO LOWER OVEN TERMINAL BLOCK AS SHOWN AT RIGHT

ELECTRICAL CONNECTIONS

POWER SUPPLY	TERMINAL BLOCK	RANGE TOP	OVEN		
			1st DECK	2nd DECK	3rd DECK
SINGLE PHASE	L1	1-3-5	1	1	1
	L2	2-4-6	2	2	2
THREE PHASE	L1	3	1	1	-
	L2	1-5	2	-	1
	L3	2-4-6	-	2	2

ELECTRICAL DATA

MODEL NUMBER	LOADING					KW TOTAL	THREE PHASE AMPS						SINGLE PHASE AMPS	
	KW PER PHASE						208 VOLT			240 VOLT			208V	240V
	L1	L2	L2 L3	L3 L1	L3 L1		L1	L2	L3	L1	L2	L3		
RF-21S	6.6	10.0	5.0	21.6	48.3	69.2	62.5	41.9	59.9	54.2	103.8	90.0		
1F-6S	6.6	0.0	0.0	6.6	31.7	31.7	00.0	27.5	27.5	0.0	31.7	27.5		
2F-6S	6.6	0.0	6.6	13.2	55.0	31.7	31.7	47.7	27.5	27.5	63.5	55.0		
3F-6S	6.6	6.6	6.6	19.8	55.0	55.0	55.0	47.7	47.7	47.7	95.2	82.5		

USE ON ALL E SERIAL NUMBERS

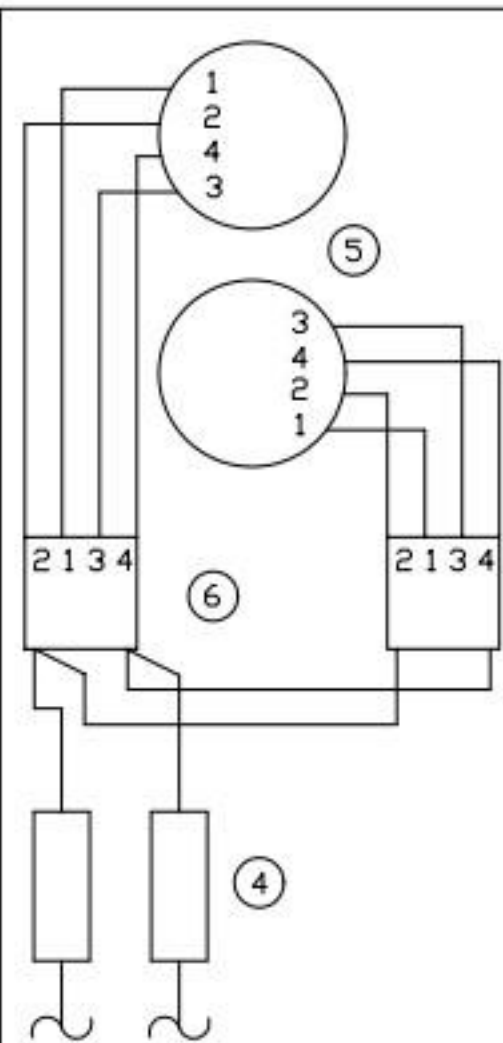
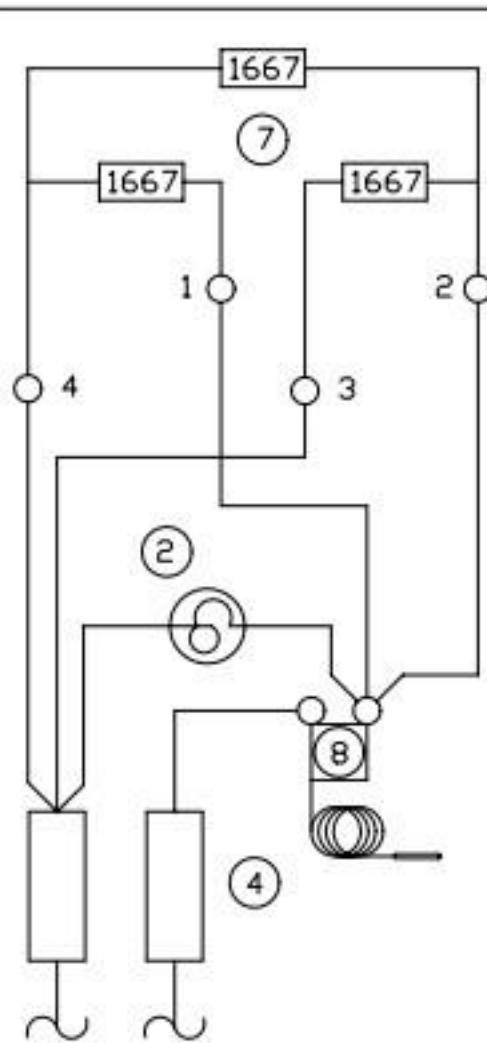
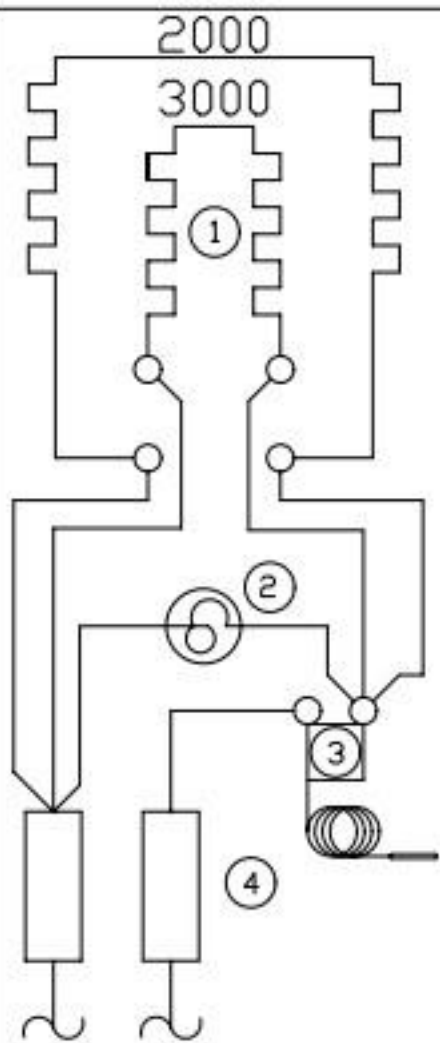

OVEN WIRING

2ND AND 3RD DECK  
WIRING IDENTICAL  
TO 1ST DECK

1ST DECK  
TERMINAL BLOCK

1 2 3

2ND DECK  
TERMINAL BLOCK

1 2 3

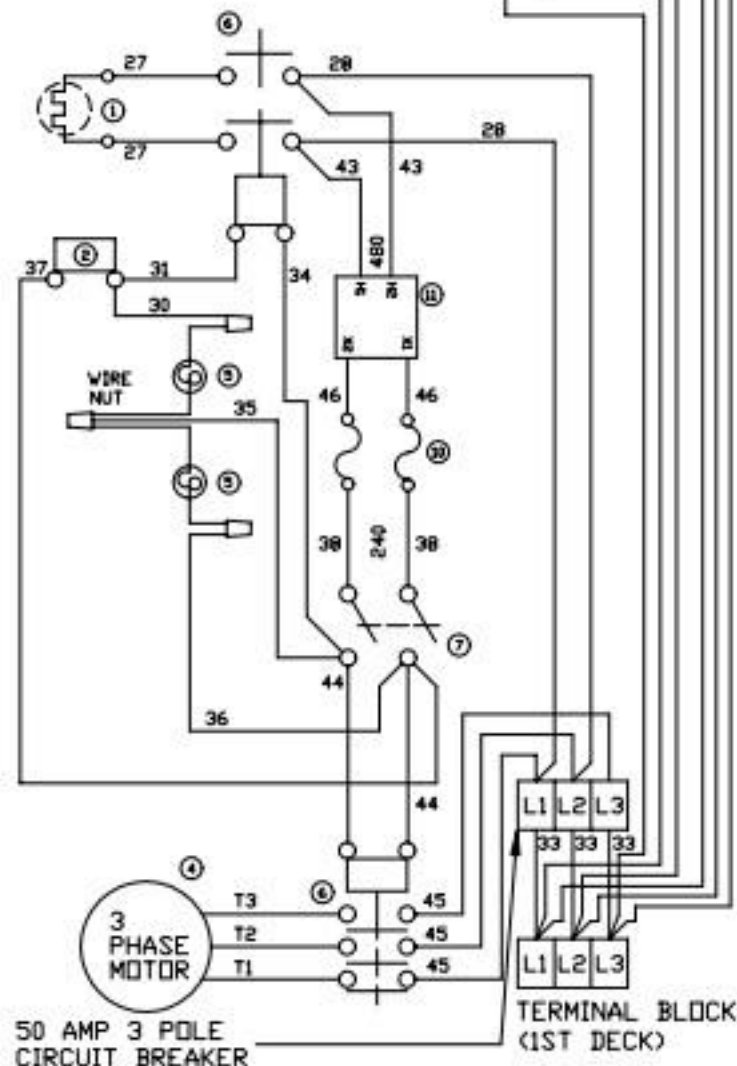

MODEL DESIGNATION	TOP ARRANGEMENT			TOP SECTION WIRE DIAGRAMS		
	SEC-1	SEC-2	SEC-3	2000	3000	TO BREAKER
RF21S-A	A	A	C			
RF21S-C	B	B	B			
RF21S-D	B	B	C			
RF21S-G	A	A	A			
RF21S-H	C	C	C			
RF21S-H	C	C	C			

- ① HEAT ELEMENT
- ② THERMOSTAT
- ③ 6 HEAT SWITCH
- ④ MOTOR
- ⑤ PILOT LAMP
- ⑥ CONTACTOR
- ⑦ POWER SWITCH
- ⑨ SPEED UNIT
- ⑩ FUSE
- ⑪ TRANSFORMER

OVEN 3 POLE  
CIRCUIT  
BREAKER

A GRILL B HOT TOP C SPEED UNITS

ELECTRICAL CONNECTIONS

CONNECT WIRE FROM RANGE  
TOP TO OVEN CIRCUIT  
BREAKER. CONNECT WIRES  
FROM ADDITIONAL DECKS  
TO LOWER OVEN TERMINAL  
BLOCK

POWER SUPPLY	RANGE TOP CONNECT TO OVEN CIRCUIT BREAKER	UPPER OVENS CONNECT TO BOTTOM DECK TERMINAL BLOCK		
		1st DECK	2nd DECK	3rd DECK
THREE PHASE	L1	3	1	2
	L2	1-5	2	3
	L3	2-4-6	3	1

CONVECTION OVEN/RANGE ELECTRICAL DATA

MODEL NUMBER	LOADING						TOTAL CONN. LOAD	AMPS THREE PHASE 480 VAC		
	KW/PHASE							L1	L2	L3
	L1	L2	L2	L3	L3	L1				
RF-21S	6.2	10.2	5.2	21.6	20.1	29.5	27.7			
1F-6S	6.2	0.2	0.2	6.6	13.2	13.2	.66			
2F-6S	6.4	0.4	6.4	13.2	23	13.9	13.9			
3F-6S	6.6	6.6	6.6	19.8	23.6	23.6	23.6			

CAUTION: CHECK OVEN FOR PROPER  
DIRECTION OF FAN ROTATION  
CHANGE PHASING OF POWER IF  
NECESSARY TO CORRECT

USE ON ALL E SERIAL NUMBERS