



# RGEA14

Parts List  
22-December-2021



*This parts list is current as of the above revision date.  
See <http://www.rheempartslists.net/92-42800-RGEA14.pdf> for the current revision.*

Package Gas-Electric

# Table of Contents

Model Explanation .....	Page 3
<b>Parts Numbers</b>	
Panels - Miscellaneous 024-036 (A Series) .....	Page 4
Panels - Miscellaneous 042-060 (A Series) .....	Page 5
Panels - Miscellaneous 036-048 (B Series) .....	Page 6
Panels - Miscellaneous 060 (C Series) .....	Page 7
Electrical Group (1) .....	Page 8
Electrical Group (2) .....	Page 9
Electrical Group (3) .....	Page 10
Electrical Group (4) .....	Page 11
Fan Group .....	Page 12
Blower Group (1) .....	Page 13
Blower Group (2) .....	Page 14
Blower Group (3) .....	Page 15
Coil Parts (1) .....	Page 16
Coil Parts (2) .....	Page 17
Coil Parts (3) .....	Page 18
Coil Parts (4) .....	Page 19
Compressor Group (1) .....	Page 20
Compressor Group (2) .....	Page 21
Compressor Group (3) .....	Page 22
Heat Exchanger-Burner Group (1) .....	Page 23
Heat Exchanger-Burner Group (2) .....	Page 24
Heat Exchanger-Burner Group (3) .....	Page 25
Heat Exchanger-Burner Group (4) .....	Page 26
Heat Exchanger-Burner Group (5) .....	Page 27
Gas Controls .....	Page 28
Accessories .....	Page 28
Orifice Selection Chart .....	Page 29
<b>Drawings/Photographs</b>	
Exploded View .....	Page 30
Control Access Panel, Evap Coil .....	Page 31
Evaporator Coil .....	Page 31
Electrical Control Box .....	Page 32
Bushings - Bulkhead Wiring .....	Page 33
Blower Assembly .....	Page 34
Coil Frames, Drainpan .....	Page 35
Condenser Coil 2 Ton .....	Page 36
Condenser Coil 2.5 - 3 Ton .....	Page 37
Condenser Coil 3.5 - 4 - 5 Ton .....	Page 38
Compressor and Refrigeration Components .....	Page 39
Heat Exchanger Assembly .....	Page 40
Collector Box - Heat Exchanger .....	Page 41
Burner Assembly .....	Page 42
Evaporator Coil Gaskets .....	Page 43
Notes/Disclaimer .....	Page 44

**MODEL NUMBER EXPLANATION**

R	G	E	A	1	4	0	3	6	A	J	D	00	1	A	A	-
(1)	(2)	(3)	(4)	(5)			(6)	(7)	(8)	(9)	(10)	(11)	(12)	(13)		

**(1) TRADENAME IDENTIFICATION**

**(2) PRODUCT CLASSIFICATION**

GE = Package Gas Electric

**(3) CABINET TYPE**

A = Residential Package

**(4) SERIES**

14 = 14 SEER

**(5) COOLING CAPACITY (Ton)**

024 = 2 ton                      042 = 3.5 ton  
 030 = 2.5 ton                    048 = 4 ton  
 036 = 3 ton                        060 = 5 ton

**(6) MAJOR SERIES**

A = 1st Design  
 B = 2nd Design  
 C = 3rd Design

**(7) ELECTRICAL DESIGNATION**

J = 208/230V - 1 PH - 60 HZ  
 C = 208/230V - 3 PH - 60 HZ  
 D = 460V - 3 PH - 60 HZ  
 Y = 575 - 3 PH - 60 HZ  
 S = 200V - 1 PH - 50 HZ  
 T = 220/240V - 1 PH - 50 HZ  
 P = 200/220V - 3 PH - 50 HZ  
 N = 380/415V - 3 PH - 50 HZ  
 V = 380V - 3 PH - 60 HZ

**(8) DRIVE PACKAGE**

A = Belt - Low Static  
 B = Belt - Medium Static  
 C = Belt - High Static  
 D = Direct Drive (PSC)  
 E = Direct Drive VFD  
 F = Belt VFD - Low Static  
 G = Belt VFD - Medium Static  
 H = Belt VFD - High Static  
 T = Constant Torque  
 V = Variable Speed

**(9) HEATING CAPACITY - (MBH)**

00 = no heat  
 04 = 40,000  
 06 = 60,000  
 08 = 80,000  
 10 = 100,000

**(10) HEAT CONFIGURATION**

1 = Single Stage  
 2 = Two Stage  
 X = Single Stage NOX  
 T = Two Stage NOX  
 0 = No Heat

**(11) CONTROL**

A = Non-Communicating  
 C = Clear Control

**(12) MINOR SERIES**

A = 1st Design  
 B = 2nd Design  
 C = 3rd Design

**(13) Option Code**

**SERIAL NUMBER EXPLANATION**

F	0	8	1	3	9	9	9	9
(1)	(2)	(3)	(4)					

**(1) PLANT CODE**

**(2) WEEK (DATE CODE)**

**(3) YEAR**

**(4) PRODUCTION NUMBER**

**Note: For Compressor Identification Number, see Compressor Code on Rating Plate  
 For Gas Code, see Control System Gas Code on Rating Plate**

No.	Notes	MODEL	RGEA14	RGEA14	RGEA14
		COOLING CAPACITY MAJOR SERIES	024 A	030 A	036 A
<b>SHEET METAL PARTS, MISCELLANEOUS</b>					
1		Front Base Pan	AS-58628-07H	AS-58628-07H	AS-58628-07H
2		Base Rail (2)	AE-58562-03	AE-58562-03	AE-58562-03
3		Base Rail (2)	AE-58562-04	AE-58562-04	AE-58562-04
4		Back Base Pan	AS-58607-64	AS-58607-64	AS-58607-64
5		Blower Shelf	AS-58630-01	AS-58630-01	AS-58630-01
6		Blower Shelf Transition	AS-58607-19	AS-58607-19	AS-58607-19
7		Divider Panel	AS-58607-03	AS-58607-03	AS-58607-03
8		Bulkhead Assembly	AS-58607-68	AS-58607-62	AS-58607-62
9		Exhaust Hood	AS-58629-01H	AS-58629-01H	AS-58629-01H
10		Combustion Air Inlet Hood	AS-58599-01H	AS-58599-01H	AS-58599-01H
11		Corner Post	AS-58607-40H	AS-58607-40H	AS-58607-40H
12		Blower Access Panel	AS-58607-09H	AS-58607-09H	AS-58607-09H
13		End Panel	AS-58607-04H	AS-58607-04H	AS-58607-04H
14		Supply Cover - Downflow	AS-58607-06H	AS-58607-06H	AS-58607-06H
14		Supply Cover - Side Option	AS-58607-35H	AS-58607-35H	AS-58607-35H
15		Return Cover - Downflow	AS-58607-05H	AS-58607-05H	AS-58607-05H
15		Return Cover - Side Option	AS-58607-34H	AS-58607-34H	AS-58607-34H
16		Top Panel	AS-58607-67H	AS-58607-67H	AS-58607-67H
17		Grille	<a href="#">95-100906-08</a>	<a href="#">95-100906-08</a>	<a href="#">95-100906-08</a>
18		Filter Access Panel	AS-58607-08H	AS-58607-08H	AS-58607-08H
19		Condenser Louver Panel	AS-58607-61H	AS-58607-61H	AS-58607-61H
20		Center Post	AS-58569-05H	AS-58569-05H	AS-58569-05H
21		Control Access Panel	AS-58607-20H	AS-58607-20H	AS-58607-20H
22		Control Box (w/o components)	AE-58597-01	AE-58597-01	AE-58597-01
23		Control Box Cover	AE-58598-01	AE-58598-01	AE-58598-01
24		Furnace Shelf	AS-58607-11	AS-58607-11	AS-58607-11
25		Burner Floor	AE-58594-01	AE-58594-01	AE-58594-01
26		Exhaust Transition	<a href="#">AS-58607-36</a>	<a href="#">AS-58607-36</a>	<a href="#">AS-58607-36</a>
27		Bulkhead Valve (2)	<a href="#">61-22369-04</a>	<a href="#">61-22369-04</a>	<a href="#">61-22369-04</a>
28		Bulkhead Valve Locknut (2)	63-22368-01	63-22368-01	63-22368-01
		Bulkhead Valve Cap (2)	83-100635-01	83-100635-01	83-100635-01
		Heat Exchanger Tube Support	AE-58590-01	AE-58590-01	AE-58590-01
		Grommet - Gas Supply Piping	56-22114-01	56-22114-01	56-22114-01
A		Star Bushing	45-18515-01	45-18515-01	45-18515-01
B		Nylon Snap Bushing	45-17057-02	45-17057-02	45-17057-02
C		Strain Relief Bushing	45-17055-11	45-17055-11	45-17055-11
D		Neoprene Gasket - 1/8 x 1/2	68-22079-04	68-22079-04	68-22079-04
E		Neoprene Gasket - 1/4 x 1/2	68-22079-06	68-22079-06	68-22079-06
F		Gasket 3/8 x 3/4	68-20243-02	68-20243-02	68-20243-02
G		Gasket 1/2 x 3/4	68-20243-01	68-20243-01	68-20243-01

No.	Notes	MODEL	RGEA14	RGEA14	RGEA14
		COOLING CAPACITY MAJOR SERIES	042 A	048 A	060 A
<b>SHEET METAL PARTS, MISCELLANEOUS</b>					
1		Front Base Pan	AS-58628-07H	AS-58628-07H	AS-58628-07H
2		Base Rail (2)	AE-58562-03	AE-58562-03	AE-58562-03
3		Base Rail (2)	AE-58562-04	AE-58562-04	AE-58562-04
4		Back Base Pan	AS-58607-64	AS-58607-64	AS-58607-64
5		Blower Shelf	AS-58630-01	AS-58630-01	AS-58630-01
6		Blower Shelf Transition	AS-58607-19	AS-58607-19	AS-58607-19
7		Divider Panel	AS-58607-03	AS-58607-03	AS-58607-03
8		Bulkhead Assembly	AS-58607-55	AS-58607-57	AS-58607-57
9		Exhaust Hood	AS-58629-01H	AS-58629-01H	AS-58629-01H
10		Combustion Air Inlet Hood	AS-58599-01H	AS-58599-01H	AS-58599-01H
11		Corner Post	AS-58607-40H	AS-58607-46H	AS-58607-46H
12		Blower Access Panel	AS-58607-09H	AS-58607-47H	AS-58607-47H
13		End Panel	AS-58607-04H	AS-58607-48H	AS-58607-48H
14		Supply Cover - Downflow	AS-58607-06H	AS-58607-06H	AS-58607-06H
14		Supply Cover - Side Option	AS-58607-35H	AS-58607-35H	AS-58607-35H
15		Return Cover - Downflow	AS-58607-05H	AS-58607-05H	AS-58607-05H
15		Return Cover - Side Option	AS-58607-34H	AS-58607-34H	AS-58607-34H
16		Top Panel	AS-58607-67H	AS-58607-67H	AS-58607-67H
17		Grille	<a href="#">95-100906-08</a>	<a href="#">95-100906-08</a>	<a href="#">95-100906-08</a>
18		Filter Access Panel	AS-58607-08H	AS-58607-49H	AS-58607-49H
19		Condenser Louver Panel	AS-58607-61H	AS-58607-56H	AS-58607-56H
20		Center Post	AS-58569-05H	AS-58569-07H	AS-58569-07H
21		Control Access Panel	AS-58607-20H	AS-58607-50H	AS-58607-50H
22		Control Box (w/o components)	AE-58597-01	AE-58597-01	AE-58597-01
23		Control Box Cover	AE-58598-01	AE-58598-01	AE-58598-01
24		Furnace Shelf	AS-58607-11	AS-58607-11	AS-58607-11
25		Burner Floor	AE-58594-01	AE-58594-01	AE-58594-01
26		Exhaust Transition	<a href="#">AS-58607-36</a>	<a href="#">AS-58607-36</a>	<a href="#">AS-58607-36</a>
27		Bulkhead Valve (2)	<a href="#">61-22369-04</a>	<a href="#">61-22369-04</a>	<a href="#">61-22369-04</a>
28		Bulkhead Valve Locknut (2)	63-22368-01	63-22368-01	63-22368-01
		Bulkhead Valve Cap (2)	83-100635-01	83-100635-01	83-100635-01
		Heat Exchanger Tube Support	AE-58590-01	AE-58590-01	AE-58590-01
		Grommet - Gas Supply Piping	56-22114-01	56-22114-01	56-22114-01
A		Star Bushing	45-18515-01	45-18515-01	45-18515-01
B		Nylon Snap Bushing	45-17057-02	45-17057-02	45-17057-02
C		Strain Relief Bushing	45-17055-11	45-17055-11	45-17055-11
D		Neoprene Gasket - 1/8 x 1/2	68-22079-04	68-22079-04	68-22079-04
E		Neoprene Gasket - 1/4 x 1/2	68-22079-06	68-22079-06	68-22079-06
F		Gasket 3/8 x 3/4	68-20243-02	68-20243-02	68-20243-02
G		Gasket 1/2 x 3/4	68-20243-01	68-20243-01	68-20243-01

No.	Notes	MODEL COOLING CAPACITY MAJOR SERIES	RGEA14 036 B	RGEA14 048 B	RGEA14 060 B
<b>SHEET METAL PARTS, MISCELLANEOUS</b>					
1		Front Base Pan	10-58628-07HT	10-58628-07HT	10-58628-07HT
2		Base Rail (2)	AE-58562-03	AE-58562-03	AE-58562-03
3		Base Rail (2)	AE-58562-04	AE-58562-04	AE-58562-04
4		Back Base Pan	AS-58607-64	AS-58607-64	AS-58607-64
5		Blower Shelf	AS-58630-01	AS-58630-01	AS-58630-01
6		Blower Shelf Transition	AS-58607-19	AS-58607-19	AS-58607-19
7		Divider Panel	AS-58607-03	AS-58607-03	AS-58607-03
8		Bulkhead Assembly	AS-58607-62	AS-58607-57	AS-58607-57
9		Exhaust Hood	AS-104910-01	AS-104910-01	AS-104910-01
10		Combustion Air Inlet Hood	AE-58599-01H T	AE-58599-01H T	AE-58599-01H T
11		Corner Post	AS-58607-40H T	AS-58607-46H T	AS-58607-46H T
12		Blower Access Panel	AS-58607-09H T	AS-58607-47H T	AS-58607-47H T
13		End Panel	AS-58607-04H T	AS-58607-48H T	AS-58607-48H T
14		Supply Cover - Side Option	AS-58607-35H T	AS-58607-35H T	AS-58607-35H T
15		Return Cover - Side Option	AS-58607-34H T	AS-58607-34H T	AS-58607-34H T
16		Top Panel	AS-58607-67H T	AS-58607-67H T	AS-58607-67H T
17		Grille	95-100906-08	95-100906-08	95-100906-08
18		Filter Access Panel	AS-58607-08H T	AS-58607-49H T	AS-58607-49H T
19		Condenser Louver Panel	AS-58607-61H T	AS-58607-56H T	AS-58607-56H T
20		Center Post	AE-58569-05H T	AE-58569-07H T	AE-58569-07H T
21		Control Access Panel	AS-58607-20H T	AS-58607-50H T	AS-58607-50H T
22		Control Box (w/o components)	AE-58597-01	AE-58597-01	AE-58597-01
23		Control Box Cover	AE-58598-01	AE-58598-01	AE-58598-01
24		Furnace Shelf	AS-58607-11	AS-58607-11	AS-58607-11
25		Burner Floor	AE-58594-01	AE-58594-01	AE-58594-01
26		Exhaust Transition	AS-58607-36	AS-58607-36	AS-58607-36
27		Bulkhead Valve (2)	61-22369-04	61-22369-04	61-22369-04
28		Bulkhead Valve Locknut (2)	63-22368-01	63-22368-01	63-22368-01
		Bulkhead Valve Cap (2)	83-100635-01	83-100635-01	83-100635-01
		Heat Exchanger Tube Support	AE-58590-01	AE-58590-01	AE-58590-01
		Grommet - Gas Supply Piping	56-22114-01	56-22114-01	56-22114-01
A		Star Bushing	45-18515-01	45-18515-01	45-18515-01
B		Nylon Snap Bushing	45-17057-02	45-17057-02	45-17057-02
C		Strain Relief Bushing	45-17055-11	45-17055-11	45-17055-11
D		Neoprene Gasket - 1/8 x 1/2	68-22079-04	68-22079-04	68-22079-04
E		Neoprene Gasket - 1/4 x 1/2	68-22079-06	68-22079-06	68-22079-06
F		Gasket 3/8 x 3/4	68-20243-02	68-20243-02	68-20243-02
G		Gasket 1/2 x 3/4	68-20243-01	68-20243-01	68-20243-01

No.	Notes	MODEL COOLING CAPACITY MAJOR SERIES	RGEA14 060 C		
<b>SHEET METAL PARTS, MISCELLANEOUS</b>					
1		Front Base Pan	10-58628-07HT		
2		Base Rail (2)	AE-58562-03		
3		Base Rail (2)	AE-58562-04		
4		Back Base Pan	AS-58607-64		
5		Blower Shelf	AS-58630-01		
6		Blower Shelf Transition	AS-58607-19		
7		Divider Panel	AS-58607-03		
8		Bulkhead Assembly	AS-58607-57		
9		Exhaust Hood	AS-104910-01		
10		Combustion Air Inlet Hood	AE-58599-01H T		
11		Corner Post	AS-58607-46H T		
12		Blower Access Panel	AS-58607-47H T		
13		End Panel	AS-58607-48H T		
14		Supply Cover - Side Option	AS-58607-35H T		
15		Return Cover - Side Option	AS-58607-34H T		
16		Top Panel	AS-58607-67H T		
17		Grille	<a href="#">95-100906-08</a>		
18		Filter Access Panel	AS-58607-49H T		
19		Condenser Louver Panel	AS-58607-56H T		
20		Center Post	AE-58569-07H T		
21		Control Access Panel	AS-58607-50H T		
22		Control Box (w/o components)	AE-58597-01		
23		Control Box Cover	AE-58598-01		
24		Furnace Shelf	AS-58607-11		
25		Burner Floor	AE-58594-01		
26		Exhaust Transition	<a href="#">AS-58607-36</a>		
27		Bulkhead Valve (2)	<a href="#">61-22369-04</a>		
28		Bulkhead Valve Locknut (2)	63-22368-01		
		Bulkhead Valve Cap (2)	83-100635-01		
		Heat Exchanger Tube Support	AE-58590-01		
		Grommet - Gas Supply Piping	56-22114-01		
A		Star Bushing	45-18515-01		
B		Nylon Snap Bushing	45-17057-02		
C		Strain Relief Bushing	45-17055-11		
D		Neoprene Gasket - 1/8 x 1/2	68-22079-04		
E		Neoprene Gasket - 1/4 x 1/2	68-22079-06		
F		Gasket 3/8 x 3/4	68-20243-02		
G		Gasket 1/2 x 3/4	68-20243-01		

No.	Notes	MODEL COOLING CAPACITY MAJOR SERIES ELECTRICAL DESIGNATION MINOR SERIES	RGEA14	RGEA14	RGEA14	RGEA14		RGEA14
			036 A C A	042 A C A	048 A C A	060 A C A	042 A C B	
<b>ELECTRICAL GROUP</b>								
31	Stk	Induced Draft Blower w/Gasket	70-23641-01	70-23641-01	70-23641-01	70-23641-01		70-23641-05
31a	Stk	Gasket - Induced Draft Blower	68-23643-01	68-23643-01	68-23643-01	68-23643-01		68-23643-01
32	Stk	Comfort Alert	N/A	N/A	N/A	N/A		N/A
33	Stk	Contactator	42-102664-08	42-102664-08	42-102664-08	42-102664-08		42-102664-08
34	Stk	Pressure Switch	42-24335-20	42-24335-20	42-24335-20	42-24335-20		42-105601-20
35	Stk	Transformer	46-18788-05	46-18788-05	46-18788-05	46-18788-05		46-18788-05
36		Ground Lug	45-19000-01	45-19000-01	45-19000-01	45-19000-01		45-19000-01
39		Integrated Furnace Control Board (IFC)	See Gas Controls					
57	Stk	Blower Relay	N/A	42-101208-02	42-101208-02	42-101208-02		42-101208-02
73		Capacitor - Compressor/Fan	See Compressor Group					
84		Limit Control - Blower Shelf	See Heat Exchanger-Burner Group					
88		Limit Control - Roll Out	See Heat Exchanger-Burner Group					
		Compressor Wiring Harness (Molded Plug)	See Compressor Group					
		Wiring Harness - 9 pin to 9 insulated terminals	AS-102393-02	AS-102393-02	AS-102393-02	AS-102393-02		45-102393-02
		Leadwire - from Flame Sensor to 9 pin Wiring Harness Plug	45-25323-02	45-25323-02	45-25323-02	45-25323-02		45-25323-02
		Capacitor Adaptor Plate (2 in. round capacitor)	AE-54609-01	AE-54609-01	AE-54609-01	AE-54609-01		N/A
		Capacitor Adaptor Plate (2 in. X 1-1/4 in. oval capacitor)	AE-54609-02	AE-54609-02	AE-54609-02	AE-54609-02		AE-54609-02

No.	Notes	MODEL COOLING CAPACITY MAJOR SERIES ELECTRICAL DESIGNATION MINOR SERIES	RGEA14	RGEA14	RGEA14			
			036 A D A	048 A D A	060 A D A			
<b>ELECTRICAL GROUP</b>								
31	Stk	Induced Draft Blower w/Gasket	70-23641-02	70-23641-02	70-23641-02			
31a	Stk	Gasket - Induced Draft Blower	68-23643-01	68-23643-01	68-23643-01			
32	Stk	Comfort Alert	NA	N/A	N/A			
33	Stk	Contactator	42-102664-08	42-102664-08	42-102664-08			
34	Stk	Pressure Switch	42-24335-20	42-24335-20	42-24335-20			
35	Stk	Transformer	46-102027-01	46-102027-01	46-102027-01			
36		Ground Lug	45-19000-01	45-19000-01	45-19000-01			
39		Integrated Furnace Control Board (IFC)	See Gas Controls					
57	Stk	Blower Relay	N/A	42-21571-08	42-21571-08			
73		Capacitor - Compressor/Fan	See Compressor Group					
84		Limit Control - Blower Shelf	See Heat Exchanger-Burner Group					
88		Limit Control - Roll Out	See Heat Exchanger-Burner Group					
		Compressor Wiring Harness (Molded Plug)	See Compressor Group					
		Wiring Harness - 9 pin to 9 insulated terminals	AS-102393-02	AS-102393-02	AS-102393-02			
		Leadwire - from Flame Sensor to 9 pin Wiring Harness Plug	45-25323-02	45-25323-02	45-25323-02			
		Capacitor Adaptor Plate (2 in. round capacitor)	AE-54609-01	AE-54609-01	AE-54609-01			
		Capacitor Adaptor Plate (2 in. X 1-1/4 in. oval capacitor)	AE-54609-02	AE-54609-02	AE-54609-02			

No.	Notes	MODEL COOLING CAPACITY MAJOR SERIES ELECTRICAL DESIGNATION MINOR SERIES	RGEA14	RGEA14	RGEA14	RGEA14	RGEA14	RGEA14
			024 A J A	030 A J A	036 A J A	042 A J A	048 A J A	060 A J A
<b>ELECTRICAL GROUP</b>								
31	Stk	Induced Draft Blower w/Gasket	70-23641-01	70-23641-01	70-23641-01	70-23641-01	70-23641-01	70-23641-01
31a	Stk	Gasket - Induced Draft Blower	68-23643-01	68-23643-01	68-23643-01	68-23643-01	68-23643-01	68-23643-01
32	Stk	Comfort Alert	N/A	N/A	N/A	N/A	N/A	N/A
33	Stk	Contactator	42-102664-06	42-102664-06	42-102664-06	42-102664-06	42-102664-06	42-102664-06
34	Stk	Pressure Switch	42-24335-20	42-24335-20	42-24335-20	42-24335-20	42-24335-20	42-24335-20
35	Stk	Transformer	46-18788-05	46-18788-05	46-18788-05	46-18788-05	46-18788-05	46-18788-05
36		Ground Lug	45-19000-01	45-19000-01	45-19000-01	45-19000-01	45-19000-01	45-19000-01
39		Integrated Furnace Control Board (IFC)	See Gas Controls					
57	Stk	Blower Relay	N/A	N/A	N/A	42-101208-02	42-101208-02	42-101208-02
73		Capacitor - Compressor/Fan	See Compressor Group					
84		Limit Control - Blower Shelf	See Heat Exchanger-Burner Group					
88		Limit Control - Roll Out	See Heat Exchanger-Burner Group					
		Compressor Wiring Harness (Molded Plug)	See Compressor Group					
		Wiring Harness - 9 pin to 9 insulated terminals	AS-102393-02	AS-102393-02	AS-102393-02	AS-102393-02	AS-102393-02	AS-102393-02
		Leadwire - from Flame Sensor to 9 pin Wiring Harness Plug	45-25323-02	45-25323-02	45-25323-02	45-25323-02	45-25323-02	45-25323-02
		Capacitor Adaptor Plate (2 in. round capacitor)	AE-54609-01	AE-54609-01	AE-54609-01	AE-54609-01	AE-54609-01	AE-54609-01
		Capacitor Adaptor Plate (2 in. X 1-1/4 in. oval capacitor)	AE-54609-02	AE-54609-02	AE-54609-02	AE-54609-02	AE-54609-02	AE-54609-02

No.	Notes	MODEL COOLING CAPACITY MAJOR SERIES ELECTRICAL DESIGNATION MINOR SERIES	RGEA14	RGEA14	RGEA14	RGEA14	RGEA14	RGEA14
			024 A J B / C	030 A J B / C	036 A J B / C	042 A J B / C	048 A J B	060 A J B
<b>ELECTRICAL GROUP</b>								
31	Stk	Induced Draft Blower w/Gasket	70-23641-05	70-23641-05	70-23641-05	70-23641-05	70-23641-05	70-23641-05
31a	Stk	Gasket - Induced Draft Blower	68-23643-01	68-23643-01	68-23643-01	68-23643-01	68-23643-01	68-23643-01
32	Stk	Comfort Alert	N/A	N/A	N/A	N/A	N/A	42-101504-05
33	Stk	Contactator	42-102664-06	42-102664-06	42-102664-06	42-102664-06	42-102664-06	42-102664-06
34	Stk	Pressure Switch	42-105601-20	42-105601-20	42-105601-20	42-105601-20	42-105601-20	42-105601-20
35	Stk	Transformer	46-18788-05	46-18788-05	46-18788-05	46-18788-05	46-18788-05	46-18788-05
36		Ground Lug	45-19000-01	45-19000-01	45-19000-01	45-19000-01	45-19000-01	45-19000-01
39		Integrated Furnace Control Board (IFC)	See Gas Controls					
57	Stk	Blower Relay	42-101208-02	42-101208-02	42-101208-02	42-101208-02	42-101208-02	42-101208-02
73		Capacitor - Compressor/Fan	See Compressor Group					
84		Limit Control - Blower Shelf	See Heat Exchanger-Burner Group					
88		Limit Control - Roll Out	See Heat Exchanger-Burner Group					
		Compressor Wiring Harness (Molded Plug)	See Compressor Group					
		Wiring Harness - 9 pin to 9 insulated terminals	45-102393-02	45-102393-02	45-102393-02	45-102393-02	45-102393-02	45-102393-02
		Leadwire - from Flame Sensor to 9 pin Wiring Harness Plug	45-25323-02	45-25323-02	45-25323-02	45-25323-02	45-25323-02	45-25323-02

No.	Notes	MODEL COOLING CAPACITY MAJOR SERIES ELECTRICAL DESIGNATION MINOR SERIES	RGEA14	RGEA14	RGEA14			
			036 B C A / B	048 B C A	060 B C A			
<b>ELECTRICAL GROUP</b>								
31	Stk	Induced Draft Blower w/Gasket	70-23641-05	70-23641-05	70-23641-05			
31a	Stk	Gasket - Induced Draft Blower	68-23643-01	68-23643-01	68-23643-01			
32	Stk	Comfort Alert	N/A	N/A	42-101504-03			
33	Stk	Contactora	42-102664-08	42-102664-08	42-102664-08			
34	Stk	Pressure Switch	42-105601-20	42-105601-20	42-105601-20			
35	Stk	Transformer	46-18788-05	46-18788-05	46-18788-05			
36		Ground Lug	45-19000-01	45-19000-01	45-19000-01			
39		Integrated Furnace Control Board (IFC)	See Gas Controls					
57	Stk	Blower Relay	42-101208-02	42-101208-02	42-101208-02			
73		Capacitor - Compressor/Fan	See Compressor Group					
84		Limit Control - Blower Shelf	See Heat Exchanger-Burner Group					
88		Limit Control - Roll Out	See Heat Exchanger-Burner Group					
		Compressor Wiring Harness (Molded Plug)	See Compressor Group					
		Wiring Harness - 9 pin to 9 insulated terminals	45-102393-02	45-102393-02	45-102393-02			
		Leadwire - from Flame Sensor to 9 pin Wiring Harness Plug	45-25323-02	45-25323-02	45-25323-02			

No.	Notes	MODEL COOLING CAPACITY MAJOR SERIES ELECTRICAL DESIGNATION MINOR SERIES	RGEA14	RGEA14	RGEA14			
			036 B D A / B	048 B D A	060 B D A			
<b>ELECTRICAL GROUP</b>								
31	Stk	Induced Draft Blower w/Gasket	70-23641-02	70-23641-02	70-23641-02			
31a	Stk	Gasket - Induced Draft Blower	68-23643-01	68-23643-01	68-23643-01			
		Relay - Induced Draft Blower	42-19736-04	42-19736-04	42-19736-04			
32	Stk	Comfort Alert	N/A	N/A	42-101504-03			
33	Stk	Contactora	42-102664-08	42-102664-08	42-102664-08			
34	Stk	Pressure Switch	42-105601-20	42-105601-20	42-105601-20			
35	Stk	Transformer	46-102027-01	46-102027-01	46-102027-01			
36		Ground Lug	45-19000-01	45-19000-01	45-19000-01			
39		Integrated Furnace Control Board (IFC)	See Gas Controls					
57	Stk	Blower Relay	42-21571-08	42-21571-08	42-21571-08			
73		Capacitor - Compressor/Fan	See Compressor Group					
84		Limit Control - Blower Shelf	See Heat Exchanger-Burner Group					
88		Limit Control - Roll Out	See Heat Exchanger-Burner Group					
		Compressor Wiring Harness (Molded Plug)	See Compressor Group					
		Wiring Harness - 9 pin to 9 insulated terminals	45-102393-02	45-102393-02	45-102393-02			
		Leadwire - from Flame Sensor to 9 pin Wiring Harness Plug	45-25323-02	45-25323-02	45-25323-02			

No.	Notes	MODEL	RGEA14	RGEA14	RGEA14
		COOLING CAPACITY	060	060	060
		MAJOR SERIES	C	C	C
		ELECTRICAL DESIGNATION	J	C	D
		MINOR SERIES	A	A	A
<b>ELECTRICAL GROUP</b>					
31	Stk	Induced Draft Blower w/Gasket	70-23641-05	70-23641-05	70-23641-02
31a	Stk	Gasket - Induced Draft Blower	<a href="#">68-23643-01</a>	<a href="#">68-23643-01</a>	<a href="#">68-23643-01</a>
32	Stk	Comfort Alert	42-101504-05	42-101504-03	42-101504-03
33	Stk	Contactora	42-102664-06	42-102664-08	42-102664-08
34	Stk	Pressure Switch	<a href="#">42-105601-20</a>	<a href="#">42-105601-20</a>	<a href="#">42-105601-20</a>
35	Stk	Transformer	46-18788-05	46-18788-05	<a href="#">46-102027-01</a>
36		Ground Lug	45-19000-01	45-19000-01	45-19000-01
39		Integrated Furnace Control Board (IFC)	See Gas Controls		
57	Stk	Blower Relay	<a href="#">42-101208-02</a>	<a href="#">42-101208-02</a>	<a href="#">42-21571-08</a>
73		Capacitor - Compressor/Fan	See Compressor Group		
84		Limit Control - Blower Shelf	See Heat Exchanger-Burner Group		
88		Limit Control - Roll Out	See Heat Exchanger-Burner Group		
		Compressor Wiring Harness (Molded Plug)	See Compressor Group		
		Wiring Harness - 9 pin to 9 insulated terminals	45-102393-02	45-102393-02	45-102393-02
		Leadwire - from Flame Sensor to 9 pin Wiring Harness Plug	<a href="#">45-25323-02</a>	<a href="#">45-25323-02</a>	<a href="#">45-25323-02</a>

No.	Notes	MODEL COOLING CAPACITY MAJOR SERIES ELECTRICAL DESIGNATION	RGEA14 036 A C	RGEA14 042 A C	RGEA14 048 A C	RGEA14 060 A C		
<b>FAN GROUP</b>								
37	Stk	Fan Motor "Minor Series A"	51-100999-24	51-100999-24	51-100998-29	51-100998-29		
		Fan Motor "Minor Series B"	N/A	51-100998-24	N/A	N/A		
38	Stk	Fan Blade	70-101323-19	70-101323-19	70-23594-02	70-23594-03		
73	Stk	Capacitor - Fan Motor	43-100496-04	43-100496-04	43-100496-12	43-100496-12		

No.	Notes	MODEL COOLING CAPACITY MAJOR SERIES ELECTRICAL DESIGNATION	RGEA14 036 A D	RGEA14 048 A D	RGEA14 060 A D			
<b>FAN GROUP</b>								
37	Stk	Fan Motor	51-100998-26	51-100998-20	51-100998-20			
38	Stk	Fan Blade	70-101323-19	70-23594-02	70-23594-03			
73	Stk	Capacitor - Fan Motor	43-100496-04	43-100496-39	43-100496-39			

No.	Notes	MODEL COOLING CAPACITY MAJOR SERIES ELECTRICAL DESIGNATION	RGEA14 024 A J	RGEA14 030 A J	RGEA14 036 A J	RGEA14 042 A J	RGEA14 048 A J	RGEA14 060 A J	
<b>FAN GROUP</b>									
37	Stk	Fan Motor "Minor Series A"	51-100999-24	51-100999-24	51-100999-24	51-100998-24	51-100998-29	51-100998-29	
		Fan Motor "Minor Series B"	51-100998-24	51-100998-24	51-100998-24	51-100998-24	51-100998-29	51-100998-29	
		Fan Motor "Minor Series C"	51-100998-24	51-100998-24	51-100998-24	51-100998-24	N/A	N/A	
38	Stk	Fan Blade	70-101323-19	70-101323-19	70-101323-19	70-101323-19	70-23594-02	70-23594-03	
73		Capacitor - Compressor/Fan Motor	See Compressor Group						

No.	Notes	MODEL COOLING CAPACITY MAJOR SERIES ELECTRICAL DESIGNATION	RGEA14 036 B C	RGEA14 048 B C	RGEA14 060 B C				
<b>FAN GROUP</b>									
37	Stk	Fan Motor "Minor Series A"	51-100998-24	51-100998-29	51-100998-29				
		Fan Motor "Minor Series B"	51-100998-24	N/A	N/A				
38	Stk	Fan Blade	70-101323-19	70-23594-02	70-23594-03				
73	Stk	Capacitor - Compressor/Fan Motor	See Compressor Group						

No.	Notes	MODEL COOLING CAPACITY MAJOR SERIES ELECTRICAL DESIGNATION	RGEA14 036 B D	RGEA14 048 B D	RGEA14 060 B D				
<b>FAN GROUP</b>									
37	Stk	Fan Motor "Minor Series A"	51-100998-26	51-100998-20	51-100998-20				
		Fan Motor "Minor Series B"	51-100998-26	N/A	N/A				
38	Stk	Fan Blade	70-101323-19	70-23594-02	70-23594-03				
73	Stk	Capacitor - Compressor/Fan Motor	See Compressor Group						

No.	Notes	MODEL COOLING CAPACITY MAJOR SERIES ELECTRICAL DESIGNATION	RGEA14 060 C J		RGEA14 060 C C		RGEA14 060 C D		
<b>FAN GROUP</b>									
37	Stk	Fan Motor	51-100998-29		51-100998-29		51-100998-20		
38	Stk	Fan Blade	70-23594-03		70-23594-03		70-23594-03		
73	Stk	Capacitor - Compressor/Fan Motor	See Compressor Group						

No.	Notes	MODEL	RGEA14	RGEA14	RGEA14	RGEA14			
		COOLING CAPACITY	036	042	048	060			
		MAJOR SERIES	A	A	A	A			
		ELECTRICAL DESIGNATION	C	C	C	C			
		DRIVE PACKAGE	D	T	T	T			
MINOR SERIES	A	A / B	A	A					
BLOWER GROUP									
	Stk	Blower Assembly (Includes items 51-56)	AS-58662-55	AS-58662-56	AS-58662-57	AS-58662-58			
51		Housing w/Wheel	70-100840-02	70-100840-02	70-100840-02	70-100840-03			
51a		Transition	AE-102207-05	AE-102207-05	AE-102207-05	AE-102207-13			
51b		Transition - Back	AE-102207-06	AE-102207-06	AE-102207-06	AE-102207-14			
52	Stk	Blower Wheel	703016	703016	703016	PD706266			
53		Cut-Off	N/A	N/A	N/A	N/A			
54	Stk	Blower Motor	51-100837-04	51-101920-25	51-101920-26	51-101984-17			
54a		Capacitor - Blower Motor	43-100496-42	N/A	N/A	N/A			
55		Motor Band	70-19927-03	70-19927-03	70-19927-03	70-19927-03			
56		Motor Arm Assembly	70-19929-09	70-19929-09	70-19929-09	70-19929-09			
56a		Hex Washer Screw (3)	63-20072-05	63-20072-05	63-20072-05	63-20072-05			
57		Blower Relay	See Electrical Group						

No.	Notes	MODEL	RGEA14	RGEA14	RGEA14				
		COOLING CAPACITY	036	048	060				
		MAJOR SERIES	A	A	A				
		ELECTRICAL DESIGNATION	D	D	D				
		DRIVE PACKAGE	D	T	T				
MINOR SERIES	A	A	A						
BLOWER GROUP									
	Stk	Blower Assembly (Includes items 51-56)	AS-58662-60	AS-58662-61	AS-58662-62				
51		Housing w/Wheel	70-100840-02	70-100840-02	70-100840-03				
51a		Transition	AE-102207-05	AE-102207-05	AE-102207-13				
51b		Transition - Back	AE-102207-06	AE-102207-06	AE-102207-14				
52	Stk	Blower Wheel	703016	703016	PD706266				
53		Cut-Off	N/A	N/A	N/A				
54	Stk	Blower Motor	51-100837-08	51-103253-07	51-103624-09				
54a		Capacitor - Blower Motor	43-100496-42	N/A	N/A				
55		Motor Band	70-19927-03	70-19927-03	70-19927-03				
56		Motor Arm Assembly	70-19929-09	70-19929-09	70-19929-09				
56a		Hex Washer Screw (3)	63-20072-05	63-20072-05	63-20072-05				
57		Blower Relay	See Electrical Group						

No.	Notes	MODEL	RGEA14	RGEA14	RGEA14	RGEA14	RGEA14	RGEA14	
		COOLING CAPACITY	024	030	036	042	048	060	
		MAJOR SERIES	A	A	A	A	A	A	
		ELECTRICAL DESIGNATION	J	J	J	J	J	J	
		DRIVE PACKAGE	D	D	D	T	T	T	
MINOR SERIES	A	A	A	A	A	A			
BLOWER GROUP									
	Stk	Blower Assembly (Includes items 51-56)	AS-58662-01	AS-58662-05	AS-58662-55	AS-58662-95	AS-58662-57	AS-58662-58	
51		Housing	AS-58619-01	AS-58619-02	N/A	N/A	N/A		
51		Housing w/Wheel	N/A	N/A	70-100840-02	70-100840-02	70-100840-02	70-100840-03	
51a		Transition	N/A	N/A	AE-102207-05	AE-102207-05	AE-102207-05	AE-102207-13	
51b		Transition - Back	N/A	N/A	AE-102207-06	AE-102207-06	AE-102207-06	AE-102207-14	
52	Stk	Blower Wheel	70-20218-01	70-18625-03	703016	703016	703016	PD706266	
53		Cut-Off	AE-64401-10	AE-64401-06	N/A	N/A	N/A	N/A	
54	Stk	Blower Motor	51-23608-02	51-23609-04	51-100837-04	51-101920-44	51-101920-26	51-101984-17	
54a		Capacitor - Blower Motor	43-100496-04	43-100496-12	43-100496-42	N/A	N/A	N/A	
		Motor Mounting Bracket Assembly (includes 55, 56)	AS-53148-03	AS-53148-03	N/A	N/A	N/A	N/A	
55		Motor Band	70-19927-01	70-19927-01	70-19927-03	70-19927-03	70-19927-03	70-19927-03	
56		Motor Arm Assembly (3)	70-19929-02	70-19929-02	70-19929-09	70-19929-09	70-19929-09	70-19929-09	
56a		Hex Washer Screw (3)	63-20072-05	63-20072-05	63-20072-05	63-20072-05	63-20072-05	63-20072-05	
57		Blower Relay	See Electrical Group						

No.	Notes	MODEL	RGEA14	RGEA14	RGEA14	RGEA14	RGEA14	RGEA14
		COOLING CAPACITY	024	030	036	042	048	060
		MAJOR SERIES	A	A	A	A	A	A
		ELECTRICAL DESIGNATION	J	J	J	J	J	J
		DRIVE PACKAGE	T	T	T	T	T	T
		MINOR SERIES	B / C	B / C	B / C	B / C	B	B
<b>BLOWER GROUP</b>								
	Stk	Blower Assembly (Includes items 51-56)	AS-58662-92	AS-58662-93	AS-58662-94	AS-58662-95	AS-58662-68	AS-58662-96
51		Housing	AS-58619-02	AS-58619-02	N/A	N/A	N/A	N/A
51		Housing w/Wheel	N/A	N/A	70-100840-02	70-100840-02	70-100840-02	70-100840-03
51a		Transition	N/A	N/A	AE-102207-05	AE-102207-05	AE-102207-05	AE-102207-13
51b		Transition - Back	N/A	N/A	AE-102207-06	AE-102207-06	AE-102207-06	AE-102207-14
52	Stk	Blower Wheel	70-18625-03	70-18625-03	703016	703016	703016	PD706266
53		Cut-Off	AE-64401-06	AE-64401-06	N/A	N/A	N/A	N/A
54	Stk	Blower Motor	51-101879-21	51-101880-33	51-101984-21	51-101920-44	51-101920-27	51-101984-17
54a		Capacitor - Blower Motor	N/A	N/A	N/A	N/A	N/A	N/A
		Motor Mounting Bracket Assembly (includes 55, 56)	AS-53148-13	AS-53148-13	N/A	N/A	N/A	N/A
55		Motor Band	70-19927-01	70-19927-01	70-19927-03	70-19927-03	70-19927-03	70-19927-03
56		Motor Arm Assembly	70-19929-02	70-19929-02	70-19929-09	70-19929-09	70-19929-09	70-19929-09
56a		Hex Washer Screw (3)	63-20072-05	63-20072-05	63-20072-05	63-20072-05	63-20072-05	63-20072-05
57		Blower Relay	See Electrical Group					

No.	Notes	MODEL	RGEA14	RGEA14	RGEA14			
		COOLING CAPACITY	036	048	060			
		MAJOR SERIES	B	B	B			
		ELECTRICAL DESIGNATION	C	C	C			
		DRIVE PACKAGE	T	T	T			
		MINOR SERIES	A / B	A	A			
<b>BLOWER GROUP</b>								
	Stk	Blower Assembly (Includes items 51-56)	AS-58662-66	AS-58662-68	AS-58662-58			
51		Housing	N/A	N/A	N/A			
51		Housing w/Wheel	70-100840-02	70-100840-02	70-100840-03			
51a		Transition	AE-102207-05	AE-102207-05	AE-102207-13			
51b		Transition - Back	AE-102207-06	AE-102207-06	AE-102207-14			
52	Stk	Blower Wheel	703016	703016	PD706266			
53		Cut-Off	N/A	N/A	N/A			
54	Stk	Blower Motor	51-101880-22	51-101920-27	51-104361-17			
54a		Capacitor - Blower Motor	N/A	N/A	N/A			
		Motor Mounting Bracket Assembly (includes 55, 56)	N/A	N/A	N/A			
55		Motor Band	70-19927-03	70-19927-03	70-19927-03			
56		Motor Arm Assembly	70-19929-09	70-19929-09	70-19929-09			
56a		Hex Washer Screw (3)	63-20072-05	63-20072-05	63-20072-05			
57		Blower Relay	See Electrical Group					

No.	Notes	MODEL	RGEA14	RGEA14	RGEA14			
		COOLING CAPACITY	036	048	060			
		MAJOR SERIES	B	B	B			
		ELECTRICAL DESIGNATION	D	D	D			
		DRIVE PACKAGE	T	T	T			
		MINOR SERIES	A / B	A	A			
<b>BLOWER GROUP</b>								
	Stk	Blower Assembly (Includes items 51-56)	AS-58662-67	AS-58662-69	AS-58662-62			
51		Housing	N/A	N/A	N/A			
51		Housing w/Wheel	70-100840-02	70-100840-02	70-100840-03			
51a		Transition	AE-102207-05	AE-102207-05	AE-102207-13			
51b		Transition - Back	AE-102207-06	AE-102207-06	AE-102207-14			
52	Stk	Blower Wheel	703016	703016	PD706266			
53		Cut-Off	N/A	N/A	N/A			
54	Stk	Blower Motor	51-103623-04	51-103253-08	51-103624-09			
54a		Capacitor - Blower Motor	N/A	N/A	N/A			
		Motor Mounting Bracket Assembly (includes 55, 56)	N/A	N/A	N/A			
55		Motor Band	70-19927-03	70-19927-03	70-19927-03			
56		Motor Arm Assembly	70-19929-09	70-19929-09	70-19929-09			
56a		Hex Washer Screw (3)	63-20072-05	63-20072-05	63-20072-05			
57		Blower Relay	See Electrical Group					

No.	Notes	MODEL	RGEA14		RGEA14		RGEA14	
		COOLING CAPACITY	060		060		060	
		MAJOR SERIES	C		C		C	
		ELECTRICAL DESIGNATION	J		C		D	
		DRIVE PACKAGE	T		T		T	
		MINOR SERIES	A		A		A	
<b>BLOWER GROUP</b>								
	Stk	Blower Assembly (Includes items 51-56)	AS-58662-96		AS-58662-96		AS-58662-62	
51		Housing	N/A		N/A		N/A	
51		Housing w/Wheel	70-100840-03		70-100840-03		70-100840-03	
51a		Transition	AE-102207-13		AE-102207-13		AE-102207-13	
51b		Transition - Back	AE-102207-14		AE-102207-14		AE-102207-14	
52	Stk	Blower Wheel	PD706266		PD706266		PD706266	
53		Cut-Off	N/A		N/A		N/A	
54	Stk	Blower Motor	51-101984-17		51-101984-17		51-103624-09	
54a		Capacitor - Blower Motor	N/A		N/A		N/A	
		Motor Mounting Bracket Assembly (includes 55, 56)	N/A		N/A		N/A	
55		Motor Band	70-19927-03		70-19927-03		70-19927-03	
56		Motor Arm Assembly	70-19929-09		70-19929-09		70-19929-09	
56a		Hex Washer Screw (3)	63-20072-05		63-20072-05		63-20072-05	
57		Blower Relay	See Electrical Group					

No.	Notes	MODEL COOLING CAPACITY MAJOR SERIES ELECTRICAL DESIGNATION MINOR SERIES	RGEA14	RGEA14	RGEA14	RGEA14
			036 A C A	042 A C A	048 A C A	060 A C A
<b>COIL GROUP</b>						
<b>CONDENSER COIL:</b>						
61	Stk	Condenser Coil (Coil Only)	AS-104395-05	AS-104395-06	AS-104395-07	AS-104395-03
61b		Pad - Bottom Coil	68-104248-03 (4)	68-104248-03 (5)	68-104248-03 (5)	68-104248-03 (5)
61c		Coil Filler Plate (2)	AS-104545-01H	AS-104545-01H	AS-104545-02H	AS-104545-02H
61d		Coil Mount	AE-101781-01	N/A	N/A	N/A
		Access Valve Body (2)	61-18542-01	61-18542-01	61-18542-01	61-18542-01
		Access Valve Core (4)	61-18551-01	61-18551-01	61-18551-01	61-18551-01
		Bulkhead Valve (2)	<a href="#">61-22369-04</a>	<a href="#">61-22369-04</a>	<a href="#">61-22369-04</a>	<a href="#">61-22369-04</a>
78	Stk	Filter Drier - Liquid Line	83-22755-05	83-22755-05	83-22755-05	83-22755-05
<b>EVAPORATOR COIL:</b>						
62	Stk	Evaporator Coil (Coil Only)	65-104387-01	65-104387-01	65-104387-02	65-104387-03
63		Drain Pan Grommet	56-23601-01	56-23601-01	56-23601-01	56-23601-01
64	Stk	Drain Pan (Before date code F2521)	68-23602-03	68-23602-03	68-23602-03	68-23602-03
		Drain Pan (On or After date code F2521)	68-108460-01	68-108460-01	68-108460-01	68-108460-01
64a		Water Block-Off (Before date code F2521)	68-104901-01	68-104901-01	68-104901-01	68-104901-01
		Water Block-Off (On or After date code F2521)	68-108461-01	68-108461-01	68-108461-01	68-108461-01
64b		Drain Trap (Attached to Drain Pan)	68-23603-01	68-23603-01	68-23603-01	68-23603-01
		Auxiliary Drain Pipe	82-58611-02	82-58611-02	82-58611-02	82-58611-02
	Stk	TXV	61-102211-37	61-102211-37	61-102211-41	<a href="#">61-102211-39</a>
67a		Frame - Coil Back Air Stop	AE-104569-01	AE-104569-01	AE-104569-02	AE-104569-02
67b		Frame - Coil Top Air Stop	AE-104571-01	AE-104571-01	AE-104571-02	AE-104571-02
68a		Frame - Coil Front Air Stop	AS-104570-01H	AS-104570-01H	AS-104570-02H	AS-104570-02H
68b		Frame - Coil Front Support	AE-104572-01	AE-104572-01	AE-104572-02	AE-104572-02

No.	Notes	MODEL COOLING CAPACITY MAJOR SERIES ELECTRICAL DESIGNATION MINOR SERIES	RGEA14		RGEA14	RGEA14	RGEA14
			042 A C B		036 A D A	048 A D A	060 A D A
<b>COIL GROUP</b>							
<b>CONDENSER COIL:</b>							
61	Stk	Condenser Coil (Coil Only)	AS-104395-13		AS-104395-05	AS-104395-07	AS-104395-03
61b		Pad - Bottom Coil	68-104248-03 (5)		68-104248-03 (4)	68-104248-03 (5)	68-104248-03 (5)
61c		Coil Filler Plate (2)	AE-104545-01H T		AS-104545-01H	AS-104545-02H	AS-104545-02H
61d		Coil Mount	N/A		AE-101781-01	N/A	N/A
		Access Valve Body (2)	61-18542-01		61-18542-01	61-18542-01	61-18542-01
		Access Valve Core (4)	61-18551-01		61-18551-01	61-18551-01	61-18551-01
		Bulkhead Valve (2)	<a href="#">61-22369-04</a>		<a href="#">61-22369-04</a>	<a href="#">61-22369-04</a>	<a href="#">61-22369-04</a>
78	Stk	Filter Drier - Liquid Line	83-104826-03		83-22755-05	83-22755-05	83-22755-05
<b>EVAPORATOR COIL:</b>							
62	Stk	Evaporator Coil (Coil Only)	65-104387-04		65-104387-01	65-104387-02	65-104387-03
63		Drain Pan Grommet	56-23601-01		56-23601-01	56-23601-01	56-23601-01
64	Stk	Drain Pan (Before date code F2521)	68-23602-03		68-23602-03	68-23602-03	68-23602-03
		Drain Pan (On or After date code F2521)	68-108460-01		68-108460-01	68-108460-01	68-108460-01
64a		Water Block-Off (Before date code F2521)	68-104901-01		68-104901-01	68-104901-01	68-104901-01
		Water Block-Off (On or After date code F2521)	68-108461-01		68-108461-01	68-108461-01	68-108461-01
64b		Drain Trap (Attached to Drain Pan)	68-23603-01		68-23603-01	68-23603-01	68-23603-01
		Auxiliary Drain Pipe	82-58611-02		82-58611-02	82-58611-02	82-58611-02
	Stk	TXV	61-102211-58		61-102211-37	61-102211-41	<a href="#">61-102211-39</a>
67a		Frame - Coil Back Air Stop	AE-104569-01		AE-104569-01	AE-104569-02	AE-104569-02
67b		Frame - Coil Top Air Stop	AE-104571-01		AE-104571-01	AE-104571-02	AE-104571-02
68a		Frame - Coil Front Air Stop	AE-104570-01H T		AS-104570-01H	AS-104570-02H	AS-104570-02H
68b		Frame - Coil Front Support	AE-104572-01		AE-104572-01	AE-104572-02	AE-104572-02

No.	Notes	MODEL COOLING CAPACITY MAJOR SERIES ELECTRICAL DESIGNATION MINOR SERIES	RGEA14	RGEA14	RGEA14	RGEA14
			024 A J A / B	030 A J A / B	036 A J A / B	042 A J A / B
<b>COIL GROUP</b>						
<b>CONDENSER COIL:</b>						
61	Stk	Condenser Coil (Coil Only)	AS-104395-01	AS-104395-02	AS-104395-05	AS-104395-06
61b		Pad - Bottom Coil	68-104248-03 (4)	68-104248-03 (4)	68-104248-03 (4)	68-104248-03 (5)
61c		Coil Filler Plate (2)	AS-104545-01H	AS-104545-01H	AS-104545-01H	AS-104545-01H
61d		Coil Mount	AE-101781-03	AE-101781-01	AE-101781-01	N/A
		Access Valve Body (2)	61-18542-01	61-18542-01	61-18542-01	61-18542-01
		Access Valve Core (4)	61-18551-01	61-18551-01	61-18551-01	61-18551-01
		Bulkhead Valve (2)	61-22369-04	61-22369-04	61-22369-04	61-22369-04
78	Stk	Filter Drier - Liquid Line (Before W2215)	83-22755-05	83-22755-05	83-22755-05	83-22755-05
78	Stk	Filter Drier - Liquid Line (On or After W2215)	83-22755-06	83-22755-06	83-22755-06	83-22755-06
<b>EVAPORATOR COIL:</b>						
62	Stk	Evaporator Coil (Coil Only)	65-104387-01	65-104387-01	65-104387-01	65-104387-01
63		Drain Pan Grommet	56-23601-01	56-23601-01	56-23601-01	56-23601-01
64	Stk	Drain Pan (Before date code F2521)	68-23602-03	68-23602-03	68-23602-03	68-23602-03
		Drain Pan (On or After date code F2521)	68-108460-01	68-108460-01	68-108460-01	68-108460-01
64a		Water Block-Off (Before date code F2521)	68-104901-01	68-104901-01	68-104901-01	68-104901-01
		Water Block-Off (On or After date code F2521)	68-108461-01	68-108461-01	68-108461-01	68-108461-01
64b		Drain Trap (Attached to Drain Pan)	68-23603-01	68-23603-01	68-23603-01	68-23603-01
		Auxiliary Drain Pipe	82-58611-02	82-58611-02	82-58611-02	82-58611-02
	Stk	TXV	61-102211-35	61-102211-36	61-102211-37	61-102211-37
67a		Frame - Coil Back Air Stop	AE-104569-01	AE-104569-01	AE-104569-01	AE-104569-01
67b		Frame - Coil Top Air Stop	AE-104571-01	AE-104571-01	AE-104571-01	AE-104571-01
68a		Frame - Coil Front Air Stop	AS-104570-01H	AS-104570-01H	AS-104570-01H	AS-104570-01H
68b		Frame - Coil Front Support	AE-104572-01	AE-104572-01	AE-104572-01	AE-104572-01

No.	Notes	MODEL COOLING CAPACITY MAJOR SERIES ELECTRICAL DESIGNATION MINOR SERIES	RGEA14	RGEA14	RGEA14
			048 A J A	060 A J A / B	048 A J B
<b>COIL GROUP</b>					
<b>CONDENSER COIL:</b>					
61	Stk	Condenser Coil (Coil Only)	AS-104395-07	AS-104395-03	AS-104395-03
61b		Pad - Bottom Coil	68-104248-03 (5)	68-104248-03 (5)	68-104248-03 (5)
61c		Coil Filler Plate (2)	AS-104545-02H	AS-104545-02H	AS-104545-02H
61d		Coil Mount	N/A	N/A	N/A
		Access Valve Body (2)	61-18542-01	61-18542-01	61-18542-01
		Access Valve Core (4)	61-18551-01	61-18551-01	61-18551-01
		Bulkhead Valve (2)	61-22369-04	61-22369-04	61-22369-04
78	Stk	Filter Drier - Liquid Line (Before W2215)	83-22755-05	83-22755-05	83-22755-05
78	Stk	Filter Drier - Liquid Line (On or After W2215)	83-22755-06	83-22755-06	83-22755-06
<b>EVAPORATOR COIL:</b>					
62	Stk	Evaporator Coil (Coil Only)	65-104387-02	65-104387-03	65-104387-03
63		Drain Pan Grommet	56-23601-01	56-23601-01	56-23601-01
64	Stk	Drain Pan (Before date code F2521)	68-23602-03	68-23602-03	68-23602-03
		Drain Pan (On or After date code F2521)	68-108460-01	68-108460-01	68-108460-01
64a		Water Block-Off (Before date code F2521)	68-104901-01	68-104901-01	68-104901-01
		Water Block-Off (On or After date code F2521)	68-108461-01	68-108461-01	68-108461-01
64b		Drain Trap (Attached to Drain Pan)	68-23603-01	68-23603-01	68-23603-01
		Auxiliary Drain Pipe	82-58611-02	82-58611-02	82-58611-02
	Stk	TXV	61-102211-41	61-102211-39	61-102211-38
67a		Frame - Coil Back Air Stop	AE-104569-02	AE-104569-02	AE-104569-02
67b		Frame - Coil Top Air Stop	AE-104571-02	AE-104571-02	AE-104571-02
68a		Frame - Coil Front Air Stop	AS-104570-02H	AS-104570-02H	AS-104570-02H
68b		Frame - Coil Front Support	AE-104572-02	AE-104572-02	AE-104572-02

No.	Notes	MODEL COOLING CAPACITY MAJOR SERIES ELECTRICAL DESIGNATION MINOR SERIES	RGEA14	RGEA14	RGEA14	RGEA14
			024 A J C	030 A J C	036 A J C	042 A J C
<b>COIL GROUP</b>						
<b>CONDENSER COIL:</b>						
61	Stk	Condenser Coil (Coil Only)	AS-104395-08	AS-104395-09	AS-104395-10	AS-104395-13
61b		Pad - Bottom Coil	68-104248-03 (4)	68-104248-03 (4)	68-104248-03 (4)	68-104248-03 (5)
61c		Coil Filler Plate (2)	AE-104545-01H T	AE-104545-01H T	AE-104545-01H T	AE-104545-01H T
61d		Coil Mount	AE-101781-03	AE-101781-01	AE-101781-01	N/A
		Access Valve Body (2)	61-18542-01	61-18542-01	61-18542-01	61-18542-01
		Access Valve Core (4)	61-18551-01	61-18551-01	61-18551-01	61-18551-01
		Bulkhead Valve (2)	61-22369-04	61-22369-04	61-22369-04	61-22369-04
78	Stk	Filter Drier - Liquid Line	83-104826-03	83-104826-03	83-104826-03	83-104826-03
<b>EVAPORATOR COIL:</b>						
62	Stk	Evaporator Coil (Coil Only)	65-104387-04	65-104387-04	65-104387-04	65-104387-04
63		Drain Pan Grommet	56-23601-01	56-23601-01	56-23601-01	56-23601-01
64	Stk	Drain Pan (Before date code F2521)	68-23602-03	68-23602-03	68-23602-03	68-23602-03
		Drain Pan (On or After date code F2521)	68-108460-01	68-108460-01	68-108460-01	68-108460-01
64a		Water Block-Off (Before date code F2521)	68-104901-01	68-104901-01	68-104901-01	68-104901-01
		Water Block-Off (On or After date code F2521)	68-108461-01	68-108461-01	68-108461-01	68-108461-01
64b		Drain Trap (Attached to Drain Pan)	68-23603-01	68-23603-01	68-23603-01	68-23603-01
		Auxiliary Drain Pipe	82-58611-02	82-58611-02	82-58611-02	82-58611-02
	Stk	TXV	61-102211-55	61-102211-56	61-102211-57	61-102211-58
67a		Frame - Coil Back Air Stop	AE-104569-01	AE-104569-01	AE-104569-01	AE-104569-01
67b		Frame - Coil Top Air Stop	AE-104571-01	AE-104571-01	AE-104571-01	AE-104571-01
68a		Frame - Coil Front Air Stop	AE-104570-01H T	AE-104570-01H T	AE-104570-01H T	AE-104570-01H T
68b		Frame - Coil Front Support	AE-104572-01	AE-104572-01	AE-104572-01	AE-104572-01

No.	Notes	MODEL COOLING CAPACITY MAJOR SERIES ELECTRICAL DESIGNATION MINOR SERIES	RGEA14	RGEA14	RGEA14	RGEA14
			036 B C A	048 B C A	060 B C A	036 B C B
<b>COIL GROUP</b>						
<b>CONDENSER COIL:</b>						
61	Stk	Condenser Coil (Coil Only)	AS-104395-05	AS-104395-03	AS-104395-03	AS-104395-10
61b		Pad - Bottom Coil	68-104248-03 (4)	68-104248-03 (5)	68-104248-03 (5)	68-104248-03 (4)
61c		Coil Filler Plate (2)	AE-104545-01H T	AE-104545-02H T	AE-104545-02H T	AE-104545-01H T
61d		Coil Mount	AE-101781-01	AE-104544-02H T	AE-104544-02H T	AE-101781-01
		Access Valve Body (2)	61-18542-01	61-18542-01	61-18542-01	61-18542-01
		Access Valve Core (4)	61-18551-01	61-18551-01	61-18551-01	61-18551-01
		Bulkhead Valve (2)	61-22369-04	61-22369-04	61-22369-04	61-22369-04
78	Stk	Filter Drier - Liquid Line	83-22755-06	83-22755-06	83-22755-06	83-104826-03
<b>EVAPORATOR COIL:</b>						
62	Stk	Evaporator Coil (Coil Only)	65-104387-01	65-104387-03	65-104387-03	65-104387-04
63		Drain Pan Grommet	56-23601-01	56-23601-01	56-23601-01	56-23601-01
64	Stk	Drain Pan (Before date code F2521)	68-23602-03	68-23602-03	68-23602-03	68-23602-03
		Drain Pan (On or After date code F2521)	68-108460-01	68-108460-01	68-108460-01	68-108460-01
64a		Water Block-Off (Before date code F2521)	68-104901-01	68-104901-01	68-104901-01	68-104901-01
		Water Block-Off (On or After date code F2521)	68-108461-01	68-108461-01	68-108461-01	68-108461-01
64b		Drain Trap (Attached to Drain Pan)	68-23603-01	68-23603-01	68-23603-01	68-23603-01
		Auxiliary Drain Pipe	82-58611-02	82-58611-02	82-58611-02	82-58611-02
	Stk	TXV	61-102211-37	61-102211-38	61-102211-39	61-102211-57
67a		Frame - Coil Back Air Stop	AE-104569-01	AE-104569-02	AE-104569-02	AE-104569-01
67b		Frame - Coil Top Air Stop	AE-104571-01	AE-104571-02	AE-104571-02	AE-104571-01
68a		Frame - Coil Front Air Stop	AE-104570-01H T	AE-104570-02H T	AE-104570-02H T	AE-104570-01H T
68b		Frame - Coil Front Support	AE-104572-01	AE-104572-02	AE-104572-02	AE-104572-01

No.	Notes	MODEL COOLING CAPACITY MAJOR SERIES ELECTRICAL DESIGNATION MINOR SERIES	RGEA14	RGEA14	RGEA14	RGEA14
			036 B D A	048 B D A	060 B D A	036 B D B
<b>COIL GROUP</b>						
<b>CONDENSER COIL:</b>						
61	Stk	Condenser Coil (Coil Only)	AS-104395-05	AS-104395-03	AS-104395-03	AS-104395-10
61b		Pad - Bottom Coil	68-104248-03 (4)	68-104248-03 (5)	68-104248-03 (5)	68-104248-03 (4)
61c		Coil Filler Plate (2)	AE-104545-01H T	AE-104545-02H T	AE-104545-02H T	AE-104545-01H T
61d		Coil Mount	AE-101781-01	AE-104544-02H T	AE-104544-02H T	AE-101781-01
		Access Valve Body (2)	61-18542-01	61-18542-01	61-18542-01	61-18542-01
		Access Valve Core (4)	61-18551-01	61-18551-01	61-18551-01	61-18551-01
		Bulkhead Valve (2)	61-22369-04	61-22369-04	61-22369-04	61-22369-04
78	Stk	Filter Drier - Liquid Line	83-22755-06	83-22755-06	83-22755-06	83-104826-03
<b>EVAPORATOR COIL:</b>						
62	Stk	Evaporator Coil (Coil Only)	65-104387-01	65-104387-03	65-104387-03	65-104387-04
63		Drain Pan Grommet	56-23601-01	56-23601-01	56-23601-01	56-23601-01
64	Stk	Drain Pan (Before date code F2521)	68-23602-03	68-23602-03	68-23602-03	68-23602-03
		Drain Pan (On or After date code F2521)	68-108460-01	68-108460-01	68-108460-01	68-108460-01
64a		Water Block-Off (Before date code F2521)	68-104901-01	68-104901-01	68-104901-01	68-104901-01
		Water Block-Off (On or After date code F2521)	68-108461-01	68-108461-01	68-108461-01	68-108461-01
64b		Drain Trap (Attached to Drain Pan)	68-23603-01	68-23603-01	68-23603-01	68-23603-01
		Auxiliary Drain Pipe	82-58611-02	82-58611-02	82-58611-02	82-58611-02
	Stk	TXV	61-102211-37	61-102211-38	61-102211-39	61-102211-57
67a		Frame - Coil Back Air Stop	AE-104569-01	AE-104569-02	AE-104569-02	AE-104569-01
67b		Frame - Coil Top Air Stop	AE-104571-01	AE-104571-02	AE-104571-02	AE-104571-01
68a		Frame - Coil Front Air Stop	AE-104570-01H T	AE-104570-02H T	AE-104570-02H T	AE-104570-01H T
68b		Frame - Coil Front Support	AE-104572-01	AE-104572-02	AE-104572-02	AE-104572-01

No.	Notes	MODEL COOLING CAPACITY MAJOR SERIES ELECTRICAL DESIGNATION MINOR SERIES	RGEA14	RGEA14	RGEA14	RGEA14
			060 C J A		060 C C A	060 C D A
<b>COIL GROUP</b>						
<b>CONDENSER COIL:</b>						
61	Stk	Condenser Coil (Coil Only)	AS-104395-03		AS-104395-03	AS-104395-03
61b		Pad - Bottom Coil	68-104248-03 (5)		68-104248-03 (5)	68-104248-03 (5)
61c		Coil Filler Plate (2)	AE-104545-02H T		AE-104545-02H T	AE-104545-02H T
61d		Coil Mount	AE-104544-02H T		AE-104544-02H T	AE-104544-02H T
		Access Valve Body (2)	61-18542-01		61-18542-01	61-18542-01
		Access Valve Core (4)	61-18551-01		61-18551-01	61-18551-01
		Bulkhead Valve (2)	61-22369-04		61-22369-04	61-22369-04
78	Stk	Filter Drier - Liquid Line	83-22755-06		83-22755-06	83-22755-06
<b>EVAPORATOR COIL:</b>						
62	Stk	Evaporator Coil (Coil Only)	65-104387-03		65-104387-03	65-104387-03
63		Drain Pan Grommet	56-23601-01		56-23601-01	56-23601-01
64	Stk	Drain Pan (Before date code F2521)	68-23602-03		68-23602-03	68-23602-03
		Drain Pan (On or After date code F2521)	68-108460-01		68-108460-01	68-108460-01
64a		Water Block-Off (Before date code F2521)	68-104901-01		68-104901-01	68-104901-01
		Water Block-Off (On or After date code F2521)	68-108461-01		68-108461-01	68-108461-01
64b		Drain Trap (Attached to Drain Pan)	68-23603-01		68-23603-01	68-23603-01
		Auxiliary Drain Pipe	82-58611-02		82-58611-02	82-58611-02
	Stk	TXV	61-102211-51		61-102211-51	61-102211-51
67a		Frame - Coil Back Air Stop	AE-104569-02		AE-104569-02	AE-104569-02
67b		Frame - Coil Top Air Stop	AE-104571-02		AE-104571-02	AE-104571-02
68a		Frame - Coil Front Air Stop	AE-104570-02H T		AE-104570-02H T	AE-104570-02H T
68b		Frame - Coil Front Support	AE-104572-02		AE-104572-02	AE-104572-02

No.	Notes	MODEL	RGEA14	RGEA14	RGEA14	RGEA14	RGEA14	
		COOLING CAPACITY	036	042	048	060	042	
		MAJOR SERIES	A	A	A	A	A	
		ELECTRICAL DESIGNATION	C	C	C	C	C	
		MINOR SERIES	A	A	A	A	B	
<b>COMPRESSOR GROUP</b>								
		<b>Compressor ID:</b>	<b>8811</b>	<b>8814</b>	<b>8817</b>	<b>8820</b>	<b>9672</b>	
71	Stk	Compressor	55-102045-90S	55-102045-19S	55-102045-08S	55-102045-117S	55-102045-19S	
72		Grommet (4)	56-18518-16	56-18518-16	56-18518-06	56-18518-06	56-18518-06	
73	Stk	Capacitor - Fan	See Fan Group					
74	Stk	Start Capacitor	N/A	N/A	N/A	N/A	N/A	
75	Stk	Start Relay	N/A	N/A	N/A	N/A	N/A	
76		High Pressure Control	47-102290-01	47-102290-01	47-102290-01	47-102290-01	47-102290-04	
77		Low Pressure Control	See Accessories Group					
	Stk	Compressor Wiring Harness (Low Voltage - Molded Plug)	N/A	N/A	N/A	N/A	N/A	
	Stk	Compressor Wiring Harness (Molded Plug)	45-100834-80	45-100834-80	45-100834-80	45-100834-80	45-100834-80	

No.	Notes	MODEL	RGEA14	RGEA14	RGEA14			
		COOLING CAPACITY	036	048	060			
		MAJOR SERIES	A	A	A			
		ELECTRICAL DESIGNATION	D	D	D			
		MINOR SERIES	A	A	A			
<b>COMPRESSOR GROUP</b>								
		<b>Compressor ID:</b>	<b>8812</b>	<b>8818</b>	<b>8821</b>			
71	Stk	Compressor	55-102045-91S	55-102045-07S	55-102045-118S			
72		Grommet (4)	56-18518-16	56-18518-06	56-18518-06			
73	Stk	Capacitor - Fan	See Fan Group					
74	Stk	Start Capacitor	N/A	N/A	N/A			
75	Stk	Start Relay	N/A	N/A	N/A			
76		High Pressure Control	47-102290-01	47-102290-01	47-102290-01			
77		Low Pressure Control	See Accessories Group					
	Stk	Compressor Wiring Harness (Low Voltage - Molded Plug)	N/A	N/A	N/A			
	Stk	Compressor Wiring Harness (Molded Plug)	45-100834-80	45-100834-80	45-100834-80			

No.	Notes	MODEL	RGEA14	RGEA14	RGEA14	RGEA14	RGEA14	RGEA14	
		COOLING CAPACITY	024	030	036	042	048	060	
		MAJOR SERIES	A	A	A	A	A	A	
		ELECTRICAL DESIGNATION	J	J	J	J	J	J	
		MINOR SERIES	A	A	A	A	A	A	
<b>COMPRESSOR GROUP</b>									
		<b>Compressor ID:</b>	<b>8808</b>	<b>8809</b>	<b>8810</b>	<b>8813</b>	<b>8816</b>	<b>8819</b>	
71	Stk	Compressor	55-102045-97S	55-102045-31S	55-102045-66S	55-102045-15S	55-102045-06S	55-102045-102S	
72		Grommet (4)	56-18518-16	56-18518-16	56-18518-16	56-18518-16	56-18518-06	56-18518-06	
73	Stk	Capacitor - Compressor/Fan	43-101665-44	43-101665-26	43-101665-41	43-101665-41	43-101665-48	43-101665-47	
74	Stk	Start Capacitor	N/A	N/A	N/A	N/A	N/A	N/A	
75	Stk	Start Relay	N/A	N/A	N/A	N/A	N/A	N/A	
76		High Pressure Control	47-102290-01	47-102290-01	47-102290-01	47-102290-01	47-102290-01	47-102290-01	
77		Low Pressure Control	See Accessories Group						
	Stk	Compressor Wiring Harness (Low Voltage - Molded Plug)	N/A	N/A	N/A	N/A	N/A	N/A	
	Stk	Compressor Wiring Harness (Molded Plug)	45-100834-80	45-100834-80	45-100834-80	45-100834-80	45-100834-80	45-100834-80	

No.	Notes	MODEL	RGEA14	RGEA14	RGEA14	RGEA14	RGEA14	RGEA14
		COOLING CAPACITY	024	030	036	042	048	060
		MAJOR SERIES	A	A	A	A	A	A
		ELECTRICAL DESIGNATION	J	J	J	J	J	J
		MINOR SERIES	B	B	B	B	B	
COMPRESSOR GROUP								
		Compressor ID:	8822	8823	8824	8813	8830	8833
71	Stk	Compressor	55-102045-97S	55-102045-31S	55-102045-66S	55-102045-15S	55-102045-06S	55-23156-34S
72		Grommet (4)	56-18518-16	56-18518-16	56-18518-16	56-18518-16	56-18518-06	56-18518-06
73	Stk	Capacitor - Compressor/Fan	43-101665-44	43-101665-26	43-101665-41	43-101665-41	43-101665-48	43-101665-36
74	Stk	Start Capacitor	N/A	N/A	N/A	N/A	N/A	43-17075-04
75	Stk	Start Relay	N/A	N/A	N/A	N/A	N/A	42-100491-26
76		High Pressure Control	47-102290-01	47-102290-01	47-102290-01	47-102290-01	47-102290-01	47-102290-01
77		Low Pressure Control	See Accessories Group					
	Stk	Compressor Wiring Harness (Low Voltage - Molded Plug) "Includes Rectifier"	N/A	N/A	N/A	N/A	N/A	45-101723-01
	Stk	Compressor Wiring Harness (Molded Plug)	45-100834-03	45-100834-03	45-100834-03	45-100834-03	45-100834-03	45-100834-03

No.	Notes	MODEL	RGEA14	RGEA14	RGEA14	RGEA14		
		COOLING CAPACITY	024	030	036	042		
		MAJOR SERIES	A	A	A	A		
		ELECTRICAL DESIGNATION	J	J	J	J		
		MINOR SERIES	C	C	C	C		
COMPRESSOR GROUP								
		Compressor ID:	9666	9667	9668	9671		
71	Stk	Compressor	55-102045-97S	55-102045-31S	55-102045-66S	55-102045-15S		
72		Grommet (4)	56-18518-16	56-18518-16	56-18518-16	56-18518-06		
73	Stk	Capacitor - Compressor/Fan	43-101665-44	43-101665-26	43-101665-41	43-101665-41		
74	Stk	Start Capacitor	N/A	N/A	N/A	N/A		
75	Stk	Start Relay	N/A	N/A	N/A	N/A		
76		High Pressure Control	47-102290-04	47-102290-04	47-102290-04	47-102290-04		
77		Low Pressure Control	See Accessories Group					
	Stk	Compressor Wiring Harness (Low Voltage - Molded Plug) "Includes Rectifier"	N/A	N/A	N/A	N/A		
	Stk	Compressor Wiring Harness (Molded Plug)	45-100834-03	45-100834-03	45-100834-03	45-100834-03		

No.	Notes	MODEL	RGEA14	RGEA14	RGEA14		RGEA14	
		COOLING CAPACITY	036	048	060		036	
		MAJOR SERIES	B	B	B		B	
		ELECTRICAL DESIGNATION	C	C	C		C	
		MINOR SERIES	A	A	A		B	
COMPRESSOR GROUP								
		Compressor ID:	8825	8831	8834		9669	
71	Stk	Compressor	55-102045-90S	55-102045-08S	55-23156-43		55-102045-90S	
72		Grommet (4)	56-18518-16	56-18518-06	56-18518-06		56-18518-16	
73	Stk	Capacitor - Compressor/Fan	43-100496-04	43-100496-12	43-100496-12		43-100496-04	
74	Stk	Start Capacitor	N/A	N/A	43-17075-04		N/A	
75	Stk	Start Relay	N/A	N/A	42-100491-26		N/A	
76		High Pressure Control	47-102290-01	47-102290-01	47-102290-01		47-102290-04	
77		Low Pressure Control	See Accessories Group		47-101529-09		See Accessories Group	
	Stk	Compressor Wiring Harness (Low Voltage - Molded Plug) "Includes Rectifier"	N/A	N/A	45-101723-01		N/A	
	Stk	Compressor Wiring Harness (Molded Plug)	45-100834-03	45-100834-03	45-100834-03		45-100834-03	

No.	Notes	MODEL	RGEA14	RGEA14	RGEA14		RGEA14
		COOLING CAPACITY	036	048	060		036
		MAJOR SERIES	B	B	B		B
		ELECTRICAL DESIGNATION	D	D	D		D
		MINOR SERIES	A	A	A		B
COMPRESSOR GROUP							
		Compressor ID:	8826	8832	8835		9670
71	Stk	Compressor	55-102045-91S	55-102045-07S	55-23156-44		55-102045-91S
72		Grommet (4)	56-18518-16	56-18518-06	56-18518-06		56-18518-16
73	Stk	Capacitor - Compressor/Fan	43-100496-04	43-100496-39	43-100496-39		43-100496-04
74	Stk	Start Capacitor	N/A	N/A	<a href="#">43-17075-04</a>		N/A
75	Stk	Start Relay	N/A	N/A	42-100491-26		N/A
76		High Pressure Control	<a href="#">47-102290-01</a>	<a href="#">47-102290-01</a>	<a href="#">47-102290-01</a>		47-102290-04
77		Low Pressure Control	See Accessories Group		<a href="#">47-101529-09</a>		See Accessories Group
	Stk	Compressor Wiring Harness (Low Voltage - Molded Plug) "Includes Rectifier"	N/A	N/A	45-101723-01		N/A
	Stk	Compressor Wiring Harness (Molded Plug)	45-100834-03	45-100834-03	45-100834-03		45-100834-03

No.	Notes	MODEL	RGEA14		RGEA14		RGEA14	
		COOLING CAPACITY	060		060		060	
		MAJOR SERIES	C		C		C	
		ELECTRICAL DESIGNATION	J		C		D	
		MINOR SERIES	A		A		A	
COMPRESSOR GROUP								
		Compressor ID:	9607		9586		9587	
71	Stk	Compressor	55-23156-69		55-23156-73		55-23156-72	
72		Grommet (4)	56-18518-06		56-18518-06		56-18518-06	
73	Stk	Capacitor - Compressor/Fan	43-101665-36		43-100496-12		43-100496-39	
74	Stk	Start Capacitor	<a href="#">43-17075-04</a>		N/A		N/A	
75	Stk	Start Relay	42-100491-26		N/A		N/A	
76		High Pressure Control	<a href="#">47-102290-01</a>		<a href="#">47-102290-01</a>		<a href="#">47-102290-01</a>	
77		Low Pressure Control	See Accessories Group					
	Stk	Compressor Wiring Harness (Low Voltage - Molded Plug)	45-101723-01		45-101723-01		45-101723-01	
	Stk	Compressor Wiring Harness (Molded Plug)	45-100834-03		45-100834-03		45-100834-03	

No.	Notes	MODEL COOLING CAPACITY MAJOR SERIES ELECTRICAL DESIGNATION DRIVE PACKAGE HEATING CAPACITY HEAT CONFIGURATION	RGEA14	RGEA14	RGEA14			
			036 A C D 06 1	036 A C D 08 1	036 A C D 10 1			
<b>HEAT EXCHANGER, BURNER / MANIFOLD</b>								
81	Stk	Heat Exchanger (Includes Center Panel and Turbulators)	AS-58632-02	AS-58632-03	AS-58632-04			
82		Turbulators	AE-58591-02 (3)	AE-58591-02 (4)	AE-58591-02 (5)			
83		Collector Box	AE-58588-01	AE-58588-01	AE-58588-01			
83a		Collector Box Gasket	68-23644-01	68-23644-01	68-23644-01			
84	Stk	Limit Control - Blower Shelf	47-102436-01	47-102436-06	47-102436-01			
85		NOX Insert Assembly	N/A	N/A	N/A			
86		Lower Burner Shield (NOX)	N/A	N/A	N/A			
87		Radiation Shield	AE-58595-01	AE-58595-01	AE-58595-01			
88	Stk	Limit - Manual Reset (Burner Compartment)	47-22861-02	47-22861-02	47-22861-02			
89	Stk	Burner Assembly (One-piece)	AS-60993-03	AS-60993-04	AS-60993-05			
90		Burner Support Bracket (2)	AE-61588-02	AE-61588-02	AE-61588-02			
91		Burner Support - (Holds Burners between Burner Support Brackets)	AE-102438-01	AE-102438-01	AE-102438-01			
92		Manifold Assembly	81-101154-01	81-101154-01	81-101154-01			
93		Burner Orifice - Natural Gas	See Orifice Selection Chart					
93		Burner Orifice - LP	See Orifice Selection Chart					
93		Number of Orifices	(3)	(4)	(5)			
94		Square Head Plug (Used on Manifold to plug extra holes)	81-23593-01 (2)	81-23593-01 (1)	N/A			
95	Stk	Flame Sensor	62-23543-02	62-23543-02	62-23543-02			
96	Stk	Ignition Electrode/Cable Assembly	62-23556-01	62-23556-01	62-23556-01			
97		Bushing	45-42519-01	45-42519-01	45-42519-01			

No.	Notes	MODEL COOLING CAPACITY MAJOR SERIES ELECTRICAL DESIGNATION DRIVE PACKAGE HEATING CAPACITY HEAT CONFIGURATION	RGEA14	RGEA14	RGEA14	RGEA14	RGEA14	
			042 A C T 08 1	042 A C T 10 1	048 A C T 08 1	048 A C T 10 1	060 A C T 10 1	
<b>HEAT EXCHANGER, BURNER / MANIFOLD</b>								
81	Stk	Heat Exchanger (Includes Center Panel and Turbulators)	AS-58632-03	AS-58632-04	AS-58632-03	AS-58632-04	AS-58632-04	
81	Stk	Heat Exchanger, AJA Stainless Steel Option (Includes Center Panel and Turbulators)	AS-58632-07	AS-58632-08	AS-58632-07	AS-58632-08	AS-58632-08	
81a		Extension Panel (w/insulation)	N/A	N/A	AS-58607-42	AS-58607-42	AS-58607-42	
82		Turbulators	AE-58591-02 (4)	AE-58591-02 (5)	AE-58591-02 (4)	AE-58591-02 (5)	AE-58591-02 (5)	
83		Collector Box	AE-58588-01	AE-58588-01	AE-58588-01	AE-58588-01	AE-58588-01	
83a		Collector Box Gasket	68-23644-01	68-23644-01	68-23644-01	68-23644-01	68-23644-01	
84	Stk	Limit Control - Blower Shelf	47-102436-06	47-102436-06	47-102436-06	47-102436-04	47-102436-07	
85		NOX Insert Assembly	N/A	N/A	N/A	N/A	N/A	
86		Lower Burner Shield (NOX)	N/A	N/A	N/A	N/A	N/A	
87		Radiation Shield	AE-58595-01	AE-58595-01	AE-58595-01	AE-58595-01	AE-58595-01	
88	Stk	Limit - Manual Reset (Burner Compartment)	47-22861-02	47-22861-02	47-22861-02	47-22861-02	47-22861-02	
89	Stk	Burner Assembly (One-piece)	AS-60993-04	AS-60993-05	AS-60993-04	AS-60993-05	AS-60993-05	
90		Burner Support Bracket (2)	AE-61588-02	AE-61588-02	AE-61588-02	AE-61588-02	AE-61588-02	
91		Burner Support - (Holds Burners between Burner Support Brackets)	AE-102438-01	AE-102438-01	AE-102438-01	AE-102438-01	AE-102438-01	
92		Manifold Assembly	81-101154-01	81-101154-01	81-101154-01	81-101154-01	81-101154-01	
93		Burner Orifice - Natural Gas	See Orifice Selection Chart					
93		Burner Orifice - LP	See Orifice Selection Chart					
93		Number of Orifices	(4)	(5)	(4)	(5)	(5)	
94		Square Head Plug (Used on Manifold to plug extra holes)	81-23593-01 (1)	N/A	81-23593-01 (1)	N/A	N/A	
95	Stk	Flame Sensor	62-23543-02	62-23543-02	62-23543-02	62-23543-02	62-23543-02	
96	Stk	Ignition Electrode/Cable Assembly	62-23556-01	62-23556-01	62-23556-01	62-23556-01	62-23556-01	
97		Bushing	45-42519-01	45-42519-01	45-42519-01	45-42519-01	45-42519-01	

No.	Notes	MODEL	RGEA14	RGEA14	RGEA14	RGEA14	RGEA14	
		COOLING CAPACITY	036	036	036	048	060	
		MAJOR SERIES	A	A	A	A	A	
		ELECTRICAL DESIGNATION	D	D	D	D	D	
		DRIVE PACKAGE	D	D	D	T	T	
		HEATING CAPACITY	06	08	10	10	10	
		HEAT CONFIGURATION	1	1	1	1	1	
<b>HEAT EXCHANGER, BURNER / MANIFOLD</b>								
81	Stk	Heat Exchanger (Includes Center Panel and Turbulators)	AS-58632-02	AS-58632-03	AS-58632-04	AS-58632-04	AS-58632-04	
81a		Extension Panel Extension (w/insulation)	N/A	N/A	N/A	AS-58607-42	AS-58607-42	
82		Turbulators	AE-58591-02 (3)	AE-58591-02 (4)	AE-58591-02 (5)	AE-58591-02 (5)	AE-58591-02 (5)	
83		Collector Box	AE-58588-01	AE-58588-01	AE-58588-01	AE-58588-01	AE-58588-01	
83a		Collector Box Gasket	68-23644-01	68-23644-01	68-23644-01	68-23644-01	68-23644-01	
84	Stk	Limit Control - Blower Shelf	47-102436-01	47-102436-06	47-102436-01	47-102436-04	47-102436-07	
85		NOX Insert Assembly	N/A	N/A	N/A	N/A	N/A	
86		Lower Burner Shield (NOX)	N/A	N/A	N/A	N/A	N/A	
87		Radiation Shield	AE-58595-01	AE-58595-01	AE-58595-01	AE-58595-01	AE-58595-01	
88	Stk	Limit - Manual Reset (Burner Compartment)	47-22861-02	47-22861-02	47-22861-02	47-22861-02	47-22861-02	
89	Stk	Burner Assembly (One-piece)	AS-60993-03	AS-60993-04	AS-60993-05	AS-60993-05	AS-60993-05	
90		Burner Support Bracket (2)	AE-61588-02	AE-61588-02	AE-61588-02	AE-61588-02	AE-61588-02	
91		Burner Support - (Holds Burners between Burner Support Brackets)	AE-102438-01	AE-102438-01	AE-102438-01	AE-102438-01	AE-102438-01	
92		Manifold Assembly	81-101154-01	81-101154-01	81-101154-01	81-101154-01	81-101154-01	
93		Burner Orifice - Natural Gas	See Orifice Selection Chart					
93		Burner Orifice - LP	See Orifice Selection Chart					
93		Number of Orifices	(3)	(4)	(5)	(5)	(5)	
94		Square Head Plug (Used on Manifold to plug extra holes)	81-23593-01 (2)	81-23593-01 (1)	N/A	N/A	N/A	
95	Stk	Flame Sensor	62-23543-02	62-23543-02	62-23543-02	62-23543-02	62-23543-02	
96	Stk	Ignition Electrode/Cable Assembly	62-23556-01	62-23556-01	62-23556-01	62-23556-01	62-23556-01	
97		Bushing	45-42519-01	45-42519-01	45-42519-01	45-42519-01	45-42519-01	

No.	Notes	MODEL	RGEA14	RGEA14	RGEA14	RGEA14	RGEA14	RGEA14
		COOLING CAPACITY	024	024	030	030	036	036
		MAJOR SERIES	A	A	A	A	A	A
		ELECTRICAL DESIGNATION	J	J	J	J	J	J
		DRIVE PACKAGE	D	D	D	D	D	D
		HEATING CAPACITY	04	06	06	08	06	08
		HEAT CONFIGURATION	1,X	1,X	1,X	1,X	1,X	1,X
<b>HEAT EXCHANGER, BURNER / MANIFOLD</b>								
81	Stk	Heat Exchanger (Includes Center Panel and Turbulators)	AS-58632-01	AS-58632-02	AS-58632-02	AS-58632-03	AS-58632-02	AS-58632-03
82		Turbulators	AE-58591-02 (2)	AE-58591-02 (3)	AE-58591-02 (3)	AE-58591-02 (4)	AE-58591-02 (3)	AE-58591-02 (4)
83		Collector Box	AE-58588-01	AE-58588-01	AE-58588-01	AE-58588-01	AE-58588-01	AE-58588-01
83a		Collector Box Gasket	68-23644-01	68-23644-01	68-23644-01	68-23644-01	68-23644-01	68-23644-01
84	Stk	Limit Control - Blower Shelf	47-102436-08	47-102436-01	47-102436-01	47-102436-06	47-102436-01	47-102436-06
85		NOX Insert Assembly	75-23684-01 (2)	75-23684-01 (3)	75-23684-01 (3)	75-23684-01 (4)	75-23684-01 (3)	75-23684-01 (4)
86		Lower Burner Shield (NOX)	AE-59148-01	AE-59148-01	AE-59148-01	AE-59148-01	AE-59148-01	AE-59148-01
87		Radiation Shield	AE-58595-01	AE-58595-01	AE-58595-01	AE-58595-01	AE-58595-01	AE-58595-01
88	Stk	Limit - Manual Reset (Burner Compartment)	47-22861-02	47-22861-02	47-22861-02	47-22861-02	47-22861-02	47-22861-02
89	Stk	Burner Assembly (One-piece)	AS-60993-02	AS-60993-03	AS-60993-03	AS-60993-04	AS-60993-03	AS-60993-04
90		Burner Support Bracket (2)	AE-61588-02	AE-61588-02	AE-61588-02	AE-61588-02	AE-61588-02	AE-61588-02
91		Burner Support - (Holds Burners between Burner Support Brackets)	AE-102438-01	AE-102438-01	AE-102438-01	AE-102438-01	AE-102438-01	AE-102438-01
92		Manifold Assembly	81-101154-01	81-101154-01	81-101154-01	81-101154-01	81-101154-01	81-101154-01
93		Burner Orifice - Natural Gas	See Orifice Selection Chart					
93		Burner Orifice - LP	See Orifice Selection Chart					
93		Number of Orifices	(2)	(3)	(3)	(4)	(3)	(4)
94		Square Head Plug (Used on Manifold to plug extra holes)	81-23593-01 (3)	81-23593-01 (2)	81-23593-01 (2)	81-23593-01 (1)	81-23593-01 (2)	81-23593-01 (1)
95	Stk	Flame Sensor	62-23543-02	62-23543-02	62-23543-02	62-23543-02	62-23543-02	62-23543-02
96	Stk	Ignition Electrode/Cable Assembly	62-23556-01	62-23556-01	62-23556-01	62-23556-01	62-23556-01	62-23556-01
97		Bushing	45-42519-01	45-42519-01	45-42519-01	45-42519-01	45-42519-01	45-42519-01

No.	Notes	MODEL COOLING CAPACITY MAJOR SERIES ELECTRICAL DESIGNATION DRIVE PACKAGE HEATING CAPACITY HEAT CONFIGURATION	RGEA14	RGEA14	RGEA14	RGEA14	RGEA14	RGEA14
			036 A J D 10 1,X	024 A J T 06 1,X	024 A J T 08 1,X	030 A J T 06 1,X	030 A J T 08 1,X	036 A J T 06 1,X
<b>HEAT EXCHANGER, BURNER / MANIFOLD</b>								
81	Stk	Heat Exchanger (Includes Center Panel and Turbulators)	AS-58632-04	AS-58632-02	AS-58632-03	AS-58632-02	AS-58632-03	AS-58632-02
81	Stk	Heat Exchanger, AJA Stainless Steel Option (Includes Center Panel and Turbulators)	N/A	AS-58632-06	AS-58632-07	AS-58632-06	AS-58632-07	AS-58632-06
82		Turbulators	AE-58591-02 (5)	AE-58591-02 (2)	AE-58591-02 (4)	AE-58591-02 (2)	AE-58591-02 (4)	AE-58591-02 (2)
83		Collector Box	AE-58588-01	AE-58588-01	AE-58588-01	AE-58588-01	AE-58588-01	AE-58588-01
83a		Collector Box Gasket	68-23644-01	68-23644-01	68-23644-01	68-23644-01	68-23644-01	68-23644-01
84	Stk	Limit Control - Blower Shelf	47-102436-01	47-102436-01	47-102436-06	47-102436-01	47-102436-06	47-102436-01
85		NOX Insert Assembly	75-23684-01 (5)	75-23684-01 (2)	75-23684-01 (4)	75-23684-01 (2)	75-23684-01 (4)	75-23684-01 (2)
86		Lower Burner Shield (NOX)	AE-59148-01	AE-59148-01	AE-59148-01	AE-59148-01	AE-59148-01	AE-59148-01
87		Radiation Shield	AE-58595-01	AE-58595-01	AE-58595-01	AE-58595-01	AE-58595-01	AE-58595-01
88	Stk	Limit - Manual Reset (Burner Compartment)	47-22861-02	47-22861-02	47-22861-02	47-22861-02	47-22861-02	47-22861-02
89	Stk	Burner Assembly (One-piece)	AS-60993-05	AS-60993-03	AS-60993-04	AS-60993-03	AS-60993-04	AS-60993-03
90		Burner Support Bracket (2)	AE-61588-02	AE-61588-02	AE-61588-02	AE-61588-02	AE-61588-02	AE-61588-02
91		Burner Support - (Holds Burners between Burner Support Brackets)	AE-102438-01	AE-102438-01	AE-102438-01	AE-102438-01	AE-102438-01	AE-102438-01
92		Manifold Assembly	81-101154-01	81-101154-01	81-101154-01	81-101154-01	81-101154-01	81-101154-01
93		Burner Orifice - Natural Gas	See Orifice Selection Chart					
93		Burner Orifice - LP	See Orifice Selection Chart					
93		Number of Orifices	(5)	(3)	(4)	(3)	(4)	(3)
94		Square Head Plug (Used on Manifold to plug extra holes)	N/A	81-23593-01 (3)	81-23593-01 (1)	81-23593-01 (3)	81-23593-01 (1)	81-23593-01 (3)
95	Stk	Flame Sensor	62-23543-02	62-23543-02	62-23543-02	62-23543-02	62-23543-02	62-23543-02
96	Stk	Ignition Electrode/Cable Assembly	62-23556-01	62-23556-01	62-23556-01	62-23556-01	62-23556-01	62-23556-01
97		Bushing	45-42519-01	45-42519-01	45-42519-01	45-42519-01	45-42519-01	45-42519-01

No.	Notes	MODEL COOLING CAPACITY MAJOR SERIES ELECTRICAL DESIGNATION DRIVE PACKAGE HEATING CAPACITY HEAT CONFIGURATION	RGEA14	RGEA14	RGEA14	RGEA14	RGEA14	RGEA14
			036 A J T 08 1,X	036 A J T 10 1,X	042 A J T 08 1,X	042 A J T 10 1,X	048 A J T 08 1,X	048 A J T 10 1,X
<b>HEAT EXCHANGER, BURNER / MANIFOLD</b>								
81	Stk	Heat Exchanger (Includes Center Panel and Turbulators)	AS-58632-03	AS-58632-04	AS-58632-03	AS-58632-04	AS-58632-03	AS-58632-04
81	Stk	Heat Exchanger, AJA Stainless Steel Option (Includes Center Panel and Turbulators)	AS-58632-07	AS-58632-08	AS-58632-07	AS-58632-08	AS-58632-07	AS-58632-08
81a		Extension Panel (w/insulation)	N/A	N/A	N/A	N/A	AS-58607-42	AS-58607-42
82		Turbulators	AE-58591-02 (4)	AE-58591-02 (5)	AE-58591-02 (4)	AE-58591-02 (5)	AE-58591-02 (4)	AE-58591-02 (5)
83		Collector Box	AE-58588-01	AE-58588-01	AE-58588-01	AE-58588-01	AE-58588-01	AE-58588-01
83a		Collector Box Gasket	68-23644-01	68-23644-01	68-23644-01	68-23644-01	68-23644-01	68-23644-01
84	Stk	Limit Control - Blower Shelf	47-102436-06	47-102436-06	47-102436-06	47-102436-06	47-102436-06	47-102436-06
85		NOX Insert Assembly	75-23684-01 (4)	75-23684-01 (5)	75-23684-01 (4)	75-23684-01 (5)	75-23684-01 (4)	75-23684-01 (5)
86		Lower Burner Shield (NOX)	AE-59148-01	AE-59148-01	AE-59148-01	AE-59148-01	AE-59148-01	AE-59148-01
87		Radiation Shield	AE-58595-01	AE-58595-01	AE-58595-01	AE-58595-01	AE-58595-01	AE-58595-01
88	Stk	Limit - Manual Reset (Burner Compartment)	47-22861-02	47-22861-02	47-22861-02	47-22861-02	47-22861-02	47-22861-02
89	Stk	Burner Assembly (One-piece)	AS-60993-04	AS-60993-05	AS-60993-04	AS-60993-05	AS-60993-04	AS-60993-05
90		Burner Support Bracket (2)	AE-61588-02	AE-61588-02	AE-61588-02	AE-61588-02	AE-61588-02	AE-61588-02
91		Burner Support - (Holds Burners between Burner Support Brackets)	AE-102438-01	AE-102438-01	AE-102438-01	AE-102438-01	AE-102438-01	AE-102438-01
92		Manifold Assembly	81-101154-01	81-101154-01	81-101154-01	81-101154-01	81-101154-01	81-101154-01
93		Burner Orifice - Natural Gas	See Orifice Selection Chart					
93		Burner Orifice - LP	See Orifice Selection Chart					
93		Number of Orifices	(4)	(5)	(4)	(5)	(4)	(5)
94		Square Head Plug (Used on Manifold to plug extra holes)	81-23593-01 (1)	N/A	81-23593-01 (1)	N/A	81-23593-01 (1)	N/A
95	Stk	Flame Sensor	62-23543-02	62-23543-02	62-23543-02	62-23543-02	62-23543-02	62-23543-02
96	Stk	Ignition Electrode/Cable Assembly	62-23556-01	62-23556-01	62-23556-01	62-23556-01	62-23556-01	62-23556-01
97		Bushing	45-42519-01	45-42519-01	45-42519-01	45-42519-01	45-42519-01	45-42519-01

No.	Notes	MODEL COOLING CAPACITY MAJOR SERIES ELECTRICAL DESIGNATION DRIVE PACKAGE HEATING CAPACITY HEAT CONFIGURATION	RGEA14	RGEA14	RGEA14	RGEA14	RGEA14	RGEA14
			060 A J T 10 1,X	036 B C T 06 1,X	036 B C T 08 1,X	036 B C T 10 1,X	048 B C T 08 1,X	048 B C T 10 1,X
<b>HEAT EXCHANGER, BURNER / MANIFOLD</b>								
81	Stk	Heat Exchanger (Includes Center Panel and Turbulators)	AS-58632-04	AS-58632-02	AS-58632-03	AS-58632-04	AS-58632-03	AS-58632-04
81	Stk	Heat Exchanger, AJA Stainless Steel Option (Includes Center Panel and Turbulators)	AS-58632-08	AS-58632-06	AS-58632-07	AS-58632-08	AS-58632-07	AS-58632-08
81a		Extension Panel (w/insulation)	AS-58607-42	N/A	N/A	N/A	AS-58607-42	AS-58607-42
82		Turbulators	AE-58591-02 (5)	AE-58591-02 (2)	AE-58591-02 (4)	AE-58591-02 (5)	AE-58591-02 (4)	AE-58591-02 (5)
83		Collector Box	AE-58588-01	AE-58588-01	AE-58588-01	AE-58588-01	AE-58588-01	AE-58588-01
83a		Collector Box Gasket	68-23644-01	68-23644-01	68-23644-01	68-23644-01	68-23644-01	68-23644-01
84	Stk	Limit Control - Blower Shelf	47-102436-07	47-102436-01	47-102436-06	47-102436-06	47-102436-06	47-102436-04
85		NOX Insert Assembly	75-23684-01 (5)	75-23684-01 (2)	75-23684-01 (4)	75-23684-01 (5)	75-23684-01 (4)	75-23684-01 (5)
86		Lower Burner Shield (NOX)	AE-59148-01	AE-59148-01	AE-59148-01	AE-59148-01	AE-59148-01	AE-59148-01
87		Radiation Shield	AE-58595-01	AE-58595-01	AE-58595-01	AE-58595-01	AE-58595-01	AE-58595-01
88	Stk	Limit - Manual Reset (Burner Compartment)	47-22861-02	47-22861-02	47-22861-02	47-22861-02	47-22861-02	47-22861-02
89	Stk	Burner Assembly (One-piece)	AS-60993-05	AS-60993-03	AS-60993-04	AS-60993-05	AS-60993-04	AS-60993-05
90		Burner Support Bracket (2)	AE-61588-02	AE-61588-02	AE-61588-02	AE-61588-02	AE-61588-02	AE-61588-02
91		Burner Support - (Holds Burners between Burner Support Brackets)	AE-102438-01	AE-102438-01	AE-102438-01	AE-102438-01	AE-102438-01	AE-102438-01
92		Manifold Assembly	81-101154-01	81-101154-01	81-101154-01	81-101154-01	81-101154-01	81-101154-01
93		Burner Orifice - Natural Gas	See Orifice Selection Chart					
93		Burner Orifice - LP	See Orifice Selection Chart					
93		Number of Orifices	(5)	(3)	(4)	(5)	(4)	(5)
94		Square Head Plug (Used on Manifold to plug extra holes)	N/A	81-23593-01 (3)	81-23593-01 (1)	N/A	81-23593-01 (1)	N/A
95	Stk	Flame Sensor	62-23543-02	62-23543-02	62-23543-02	62-23543-02	62-23543-02	62-23543-02
96	Stk	Ignition Electrode/Cable Assembly	62-23556-01	62-23556-01	62-23556-01	62-23556-01	62-23556-01	62-23556-01
97		Bushing	45-42519-01	45-42519-01	45-42519-01	45-42519-01	45-42519-01	45-42519-01

No.	Notes	MODEL COOLING CAPACITY MAJOR SERIES ELECTRICAL DESIGNATION DRIVE PACKAGE HEATING CAPACITY HEAT CONFIGURATION	RGEA14					
			060 B C T 10 1,X					
<b>HEAT EXCHANGER, BURNER / MANIFOLD</b>								
81	Stk	Heat Exchanger (Includes Center Panel and Turbulators)	AS-58632-04					
81	Stk	Heat Exchanger, AJA Stainless Steel Option (Includes Center Panel and Turbulators)	AS-58632-08					
81a		Extension Panel (w/insulation)	AS-58607-42					
82		Turbulators	AE-58591-02 (5)					
83		Collector Box	AE-58588-01					
83a		Collector Box Gasket	68-23644-01					
84	Stk	Limit Control - Blower Shelf	47-102436-07					
85		NOX Insert Assembly	75-23684-01 (2)					
86		Lower Burner Shield (NOX)	AE-59148-01					
87		Radiation Shield	AE-58595-01					
88	Stk	Limit - Manual Reset (Burner Compartment)	47-22861-02					
89	Stk	Burner Assembly (One-piece)	AS-60993-05					
90		Burner Support Bracket (2)	AE-61588-02					
91		Burner Support - (Holds Burners between Burner Support Brackets)	AE-102438-01					
92		Manifold Assembly	81-101154-01					
93		Burner Orifice - Natural Gas	See Orifice Selection Chart					
93		Burner Orifice - LP	See Orifice Selection Chart					
93		Number of Orifices	(5)					
94		Square Head Plug (Used on Manifold to plug extra holes)	N/A					
95	Stk	Flame Sensor	62-23543-02					
96	Stk	Ignition Electrode/Cable Assembly	62-23556-01					
97		Bushing	45-42519-01					

No.	Notes	MODEL COOLING CAPACITY MAJOR SERIES ELECTRICAL DESIGNATION DRIVE PACKAGE HEATING CAPACITY HEAT CONFIGURATION	RGEA14	RGEA14	RGEA14	RGEA14	RGEA14
			036 B D T 06 1,X	036 B D T 08 1,X	036 B D T 10 1,X	048 B D T 10 1,X	060 B D T 10 1,X
<b>HEAT EXCHANGER, BURNER / MANIFOLD</b>							
81	Stk	Heat Exchanger (Includes Center Panel and Turbulators)	AS-58632-02	AS-58632-03	AS-58632-04	AS-58632-04	AS-58632-04
81	Stk	Heat Exchanger, AJA Stainless Steel Option (Includes Center Panel and Turbulators)	AS-58632-06	AS-58632-07	AS-58632-08	AS-58632-08	AS-58632-08
81a		Extension Panel (w/insulation)	N/A	N/A	N/A	AS-58607-42	AS-58607-42
82		Turbulators	AE-58591-02 (2)	AE-58591-02 (4)	AE-58591-02 (5)	AE-58591-02 (5)	AE-58591-02 (5)
83		Collector Box	AE-58588-01	AE-58588-01	AE-58588-01	AE-58588-01	AE-58588-01
83a		Collector Box Gasket	68-23644-01	68-23644-01	68-23644-01	68-23644-01	68-23644-01
84	Stk	Limit Control - Blower Shelf	47-102436-01	47-102436-06	47-102436-06	47-102436-04	47-102436-07
85		NOX Insert Assembly	75-23684-01 (2)	75-23684-01 (4)	75-23684-01 (5)	75-23684-01 (5)	75-23684-01 (5)
86		Lower Burner Shield (NOX)	AE-59148-01	AE-59148-01	AE-59148-01	AE-59148-01	AE-59148-01
87		Radiation Shield	AE-58595-01	AE-58595-01	AE-58595-01	AE-58595-01	AE-58595-01
88	Stk	Limit - Manual Reset (Burner Compartment)	47-22861-02	47-22861-02	47-22861-02	47-22861-02	47-22861-02
89	Stk	Burner Assembly (One-piece)	AS-60993-03	AS-60993-04	AS-60993-05	AS-60993-05	AS-60993-05
90		Burner Support Bracket (2)	AE-61588-02	AE-61588-02	AE-61588-02	AE-61588-02	AE-61588-02
91		Burner Support - (Holds Burners between Burner Support Brackets)	AE-102438-01	AE-102438-01	AE-102438-01	AE-102438-01	AE-102438-01
92		Manifold Assembly	81-101154-01	81-101154-01	81-101154-01	81-101154-01	81-101154-01
93		Burner Orifice - Natural Gas	See Orifice Selection Chart				
93		Burner Orifice - LP	See Orifice Selection Chart				
93		Number of Orifices	(3)	(4)	(5)	(5)	(5)
94		Square Head Plug (Used on Manifold to plug extra holes)	81-23593-01 (3)	81-23593-01 (1)	N/A	N/A	N/A
95	Stk	Flame Sensor	62-23543-02	62-23543-02	62-23543-02	62-23543-02	62-23543-02
96	Stk	Ignition Electrode/Cable Assembly	62-23556-01	62-23556-01	62-23556-01	62-23556-01	62-23556-01
97		Bushing	45-42519-01	45-42519-01	45-42519-01	45-42519-01	45-42519-01

No.	Notes	MODEL COOLING CAPACITY MAJOR SERIES ELECTRICAL DESIGNATION DRIVE PACKAGE HEATING CAPACITY HEAT CONFIGURATION	RGEA14		RGEA14		RGEA14
			060 C J T 10 1,X		060 C C T 10 1,X		060 C D T 10 1,X
<b>HEAT EXCHANGER, BURNER / MANIFOLD</b>							
81	Stk	Heat Exchanger (Includes Center Panel and Turbulators)	AS-58632-04		AS-58632-04		AS-58632-04
81	Stk	Heat Exchanger, AJA Stainless Steel Option (Includes Center Panel and Turbulators)	AS-58632-08		AS-58632-08		AS-58632-08
81a		Extension Panel (w/insulation)	AS-58607-42		AS-58607-42		AS-58607-42
82		Turbulators	AE-58591-02 (5)		AE-58591-02 (5)		AE-58591-02 (5)
83		Collector Box	AE-58588-01		AE-58588-01		AE-58588-01
83a		Collector Box Gasket	68-23644-01		68-23644-01		68-23644-01
84	Stk	Limit Control - Blower Shelf	47-102436-07		47-102436-07		47-102436-07
85		NOX Insert Assembly	75-23684-01 (5)		75-23684-01 (5)		75-23684-01 (5)
86		Lower Burner Shield (NOX)	AE-59148-01		AE-59148-01		AE-59148-01
87		Radiation Shield	AE-58595-01		AE-58595-01		AE-58595-01
88	Stk	Limit - Manual Reset (Burner Compartment)	47-22861-02		47-22861-02		47-22861-02
89	Stk	Burner Assembly (One-piece)	AS-60993-05		AS-60993-05		AS-60993-05
90		Burner Support Bracket (2)	AE-61588-02		AE-61588-02		AE-61588-02
91		Burner Support - (Holds Burners between Burner Support Brackets)	AE-102438-01		AE-102438-01		AE-102438-01
92		Manifold Assembly	81-101154-01		81-101154-01		81-101154-01
93		Burner Orifice - Natural Gas	See Orifice Selection Chart				
93		Burner Orifice - LP	See Orifice Selection Chart				
93		Number of Orifices	(5)		(5)		(5)
94		Square Head Plug (Used on Manifold to plug extra holes)	N/A		N/A		N/A
95	Stk	Flame Sensor	62-23543-02		62-23543-02		62-23543-02
96	Stk	Ignition Electrode/Cable Assembly	62-23556-01		62-23556-01		62-23556-01
97		Bushing	45-42519-01		45-42519-01		45-42519-01

No.	Notes	MODEL GAS CODE	RGEA14 2G	RGEA14 2U	RGEA14 2W
<b>GAS CONTROLS</b>					
39	Stk	Integrated Furnace Control Board (IFC)	62-23599-04	62-23599-04	62-23599-04
40	Stk, 2	Gas Valve - Natural Gas (See Note 2 for the "2W" Gas Code)	60-100394-02	<a href="#">60-105055-01</a>	<a href="#">60-105055-01</a>
	Stk,1,2	Gas Valve - LP (See Note 1, 2)	See Note 1	See Note 1	See Note 1
	Stk,1,2	LP Conversion Kit (See Note 1, 2)	EP-85H	EP-85H	<a href="#">EP-94D</a>

No.	Notes	MODEL VARIATIONS			RGEA14 ALL
<b>OPTIONS AND ACCESSORIES</b>					
		Economizer - Downflow, 3 Position			AXRE-CAA30
		Economizer - Downflow, Fully Modulating			AXRD-CAM10
		Economizer - Horizontal, 3 Position			AXRE-CCA30
		Economizer - Horizontal, Fully Modulating			AXRD-CCM10
		Fresh Air Damper - Fixed, 35%			AXRF-FAA1
		Fresh Air Damper - Motorized, 35%			AXRF-FAB1
		Low Ambient Control			RXRZ-B01
76		High Pressure Control			RXAB-E01
77		Low Pressure Control			RXAC-C01

**PACKAGE EQUIPMENT - ORIFICE SELECTION CHART - NATURAL GAS**

**CAUTION:** Selection of the correct Natural Gas Orifice requires the following information for the specific installation:

- 1) Furnace Input Rating (BTU/HR)
- 2) Number of Burners
- 2) Altitude (ft.)

For detailed information and instructions for Orifice selection, see the Gas Furnace LP Conversion Kit Index 92-21519-47 and the latest edition of the National Fuel Gas Code Handbook, or the National Standard of Canada, Natural Gas and Propane Installation Code, CAN B149.1.

**CAUTION:** This information is provided for replacement purposes only. Conversion for operation at High Altitude must be done using the kit specified on the product specification sheet for the unit.

NOTE: This Orifice sizing chart is based on a Natural Gas heating value of 1075 BTU/cu. ft and a pressure setting of 3.5 in. water column.

NOTE: Factory installed orifices are calculated and sized based on a Natural Gas heating value of 1075 BTU/cu. ft. and an elevation of 0 - 2000 ft.

Furnace Input Rating (BTU/HR)	Canadian High Altitude Derated Input (BTU/HR)	Number of Burners	Elevation (ft.)					
			Country					
			0 - 2000 U.S.	2001 - 4000 U.S.	4001 - 6000 U.S.	8000+ U.S.	0 - 2000 Canada	2001 - 4500 Canada
40,000	36,000	2	62-22175-45	62-22175-47	62-22175-48	62-22175-49	62-22175-45	62-22175-15
60,000	54,000	3	62-22175-45	62-22175-47	62-22175-48	62-22175-49	62-22175-45	62-22175-15
72,000	N/A	4	62-22175-15	62-22175-49	62-22175-50	62-22175-51	62-22175-15	N/A
80,000	72,000	4	62-22175-45	62-22175-47	62-22175-48	62-22175-49	62-22175-45	62-22175-15
90,000	N/A	5	62-22175-15	62-22175-49	62-22175-50	62-22175-51	62-22175-15	N/A
100,000	90,000	5	62-22175-45	62-22175-47	62-22175-48	62-22175-49	62-22175-45	62-22175-15
120,000	108,000	6	62-22175-45	62-22175-47	62-22175-48	62-22175-49	62-22175-45	62-22175-15
135,000	121,500	6	62-22175-44	62-22175-45	62-22175-47	62-22175-48	62-22175-44	62-22175-45
150,000	135,000	6	62-22175-42	62-22175-43	62-22175-44	62-22175-45	62-22175-42	62-22175-44
180,000	N/A	9	62-22175-45	62-22175-47	62-22175-48	62-22175-49	62-22175-45	N/A
210,000	N/A	9	62-22175-43	62-22175-44	62-22175-45	62-22175-47	62-22175-43	N/A
210,000	N/A	10	62-22175-45	62-22175-47	62-22175-48	62-22175-49	62-22175-45	N/A
225,000	202,500	9	62-22175-42	62-22175-43	62-22175-44	62-22175-45	62-22175-42	62-22175-44
250,000	225,000	10	62-22175-42	62-22175-43	62-22175-44	62-22175-45	62-22175-42	62-22175-44
252,000	225,000	9	62-22175-40	62-22175-42	62-22175-43	62-22175-44	62-22175-40	62-22175-42
252,000	N/A	12	62-22175-45	62-22175-47	62-22175-48	62-22175-49	62-22175-45	N/A
290,000	N/A	14	62-22175-45	62-22175-47	62-22175-48	62-22175-49	62-22175-45	N/A
300,000	270,000	12	62-22175-42	62-22175-43	62-22175-44	62-22175-45	62-22175-42	62-22175-44
330,000	N/A	14	62-22175-43	62-22175-44	62-22175-45	62-22175-47	62-22175-43	N/A
350,000	315,000	14	62-22175-42	62-22175-43	62-22175-44	62-22175-45	62-22175-42	62-22175-44
400,000	360,000	14	62-22175-40	62-22175-42	62-22175-43	62-22175-44	62-22175-40	62-22175-42

**PACKAGE EQUIPMENT - ORIFICE SELECTION CHART - LP**

**CAUTION:** Selection of the correct LP Orifice requires the following information for the specific installation:

- 1) Furnace Input Rating (BTU/HR)
- 2) Number of Burners
- 2) Altitude (ft.)

For detailed information and instructions for Orifice selection, see the Gas Furnace LP Conversion Kit Index 92-21519-47 and the latest edition of the National Fuel Gas Code Handbook, or the National Standard of Canada, Natural Gas and Propane Installation Code, CAN B149.1.

**CAUTION:** This information is provided for replacement purposes only. Conversion to LP or for operation at High Altitude should be done using the kit(s) specified on the product specification sheet for the unit.

NOTE: This Orifice sizing chart is developed using the specified pressure setting of 10 in. water column instead of the 11.0 in water column used by the NFG and CANB149.1.

NOTE: Orifices supplied in the LP Conversion Kit are calculated and sized based on a heating value of 2500 BTU/cu. ft. and an elevation of 0 - 2000 ft.

Furnace Input Rating (BTU/HR)	Canadian High Altitude Derated Input (BTU/HR)	Number of Burners	Elevation (ft.)					
			Country					
			0 - 2000 U.S.	2001 - 4000 U.S.	4001 - 6000 U.S.	8000+ U.S.	0 - 2000 Canada	2001 - 4500 Canada
40,000	36,000	2	62-22175-55	62-22175-55	62-22175-56	62-22175-56	62-22175-55	62-22175-13
60,000	54,000	3	62-22175-55	62-22175-55	62-22175-56	62-22175-56	62-22175-55	62-22175-13
72,000	N/A	4	62-22175-13	62-22175-57	62-22175-57	62-22175-59	62-22175-13	N/A
80,000	72,000	4	62-22175-55	62-22175-55	62-22175-56	62-22175-56	62-22175-55	62-22175-13
90,000	N/A	5	62-22175-13	62-22175-57	62-22175-57	62-22175-59	62-22175-13	N/A
100,000	90,000	5	62-22175-55	62-22175-55	62-22175-56	62-22175-56	62-22175-55	62-22175-13
120,000	108,000	6	62-22175-55	62-22175-55	62-22175-56	62-22175-56	62-22175-55	62-22175-13
135,000	121,500	6	62-22175-54	62-22175-55	62-22175-55	62-22175-56	62-22175-54	62-22175-55
150,000	135,000	6	62-22175-54	62-22175-55	62-22175-55	62-22175-56	62-22175-54	62-22175-54
180,000	N/A	9	62-22175-55	62-22175-55	62-22175-56	62-22175-56	62-22175-55	N/A
210,000	N/A	9	62-22175-54	62-22175-55	62-22175-55	62-22175-56	62-22175-54	N/A
210,000	N/A	10	62-22175-55	62-22175-55	62-22175-56	62-22175-56	62-22175-55	N/A
225,000	202,500	9	62-22175-54	62-22175-55	62-22175-55	62-22175-56	62-22175-54	62-22175-54
250,000	225,000	10	62-22175-54	62-22175-55	62-22175-55	62-22175-56	62-22175-54	62-22175-54
252,000	225,000	9	62-22175-53	62-22175-54	62-22175-54	62-22175-55	62-22175-53	62-22175-54
252,000	N/A	12	62-22175-55	62-22175-55	62-22175-56	62-22175-56	62-22175-55	N/A
290,000	N/A	14	62-22175-55	62-22175-55	62-22175-56	62-22175-56	62-22175-55	N/A
300,000	270,000	12	62-22175-54	62-22175-55	62-22175-55	62-22175-56	62-22175-54	62-22175-54
330,000	N/A	14	62-22175-54	62-22175-55	62-22175-55	62-22175-56	62-22175-54	N/A
350,000	315,000	14	62-22175-54	62-22175-55	62-22175-55	62-22175-56	62-22175-54	62-22175-54
400,000	360,000	14	62-22175-53	62-22175-54	62-22175-54	62-22175-55	62-22175-53	62-22175-54

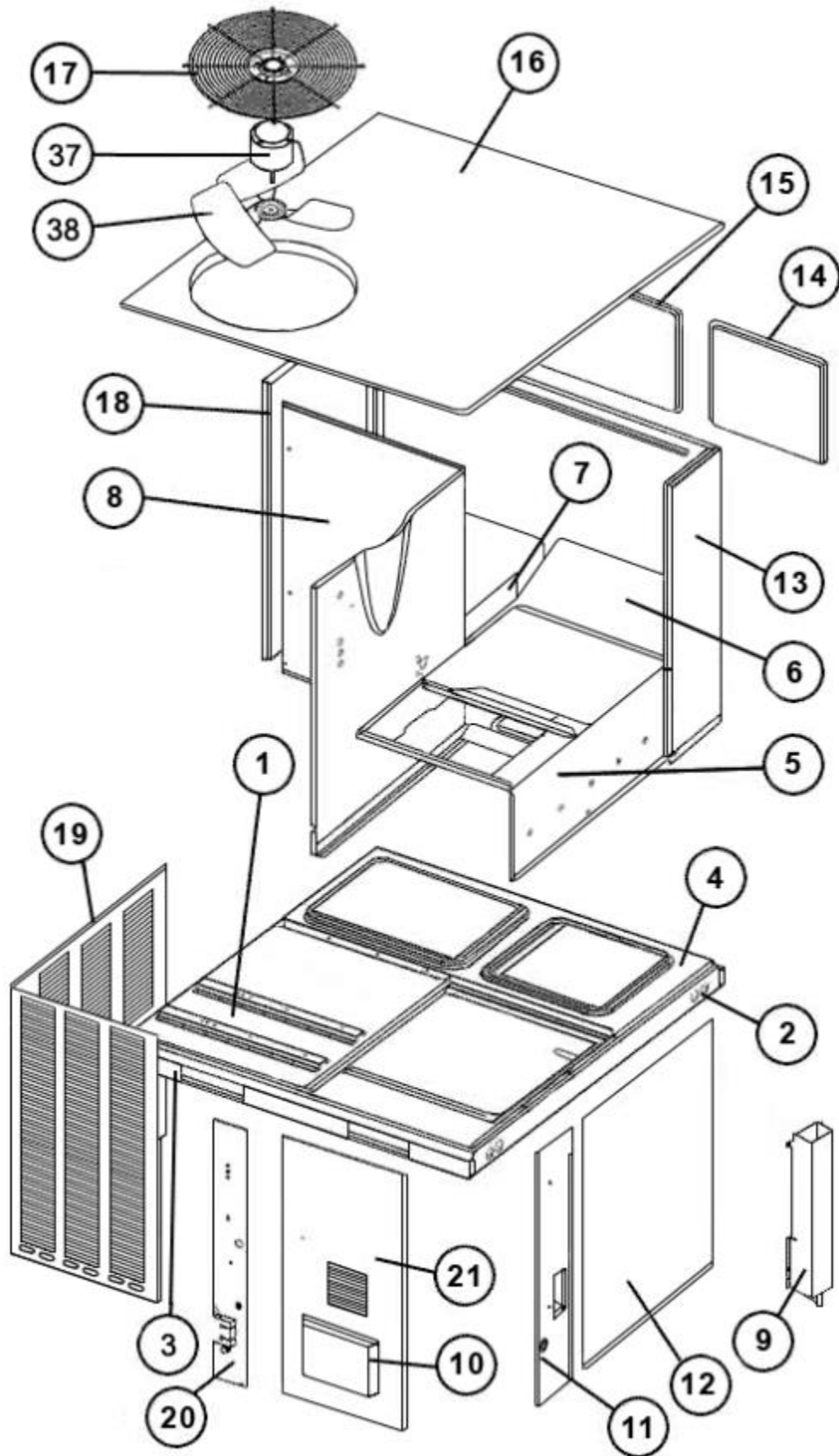

Exploded View

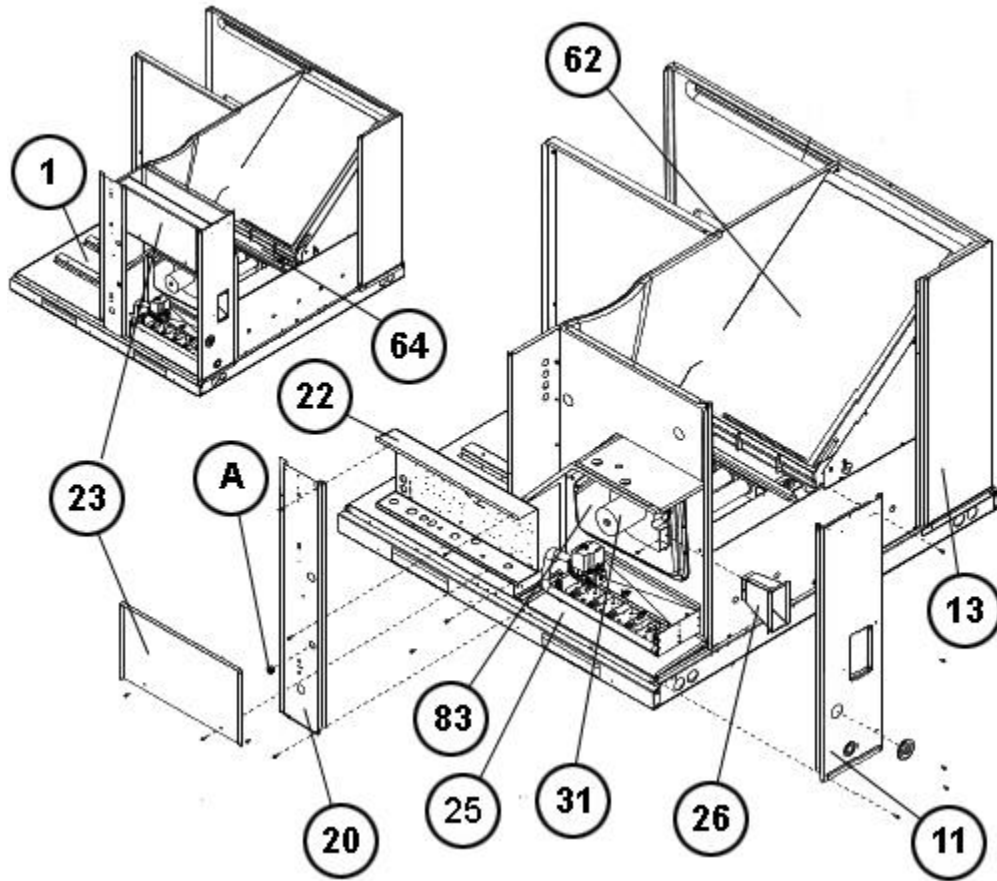

Control Access Panel, Evap Coil

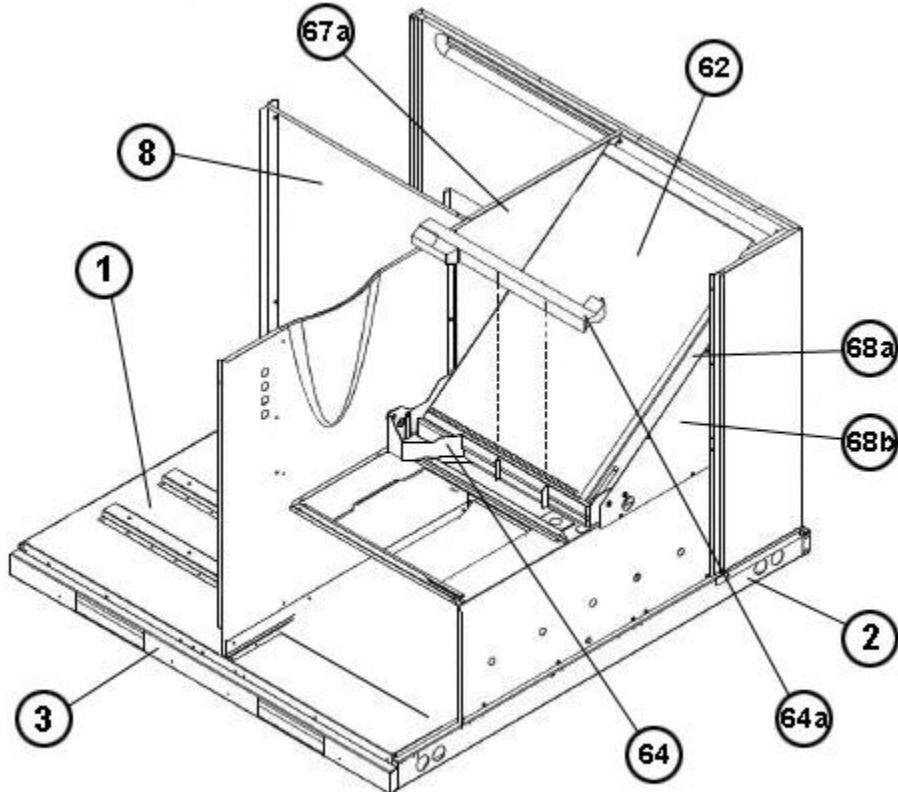

Evaporator Coil

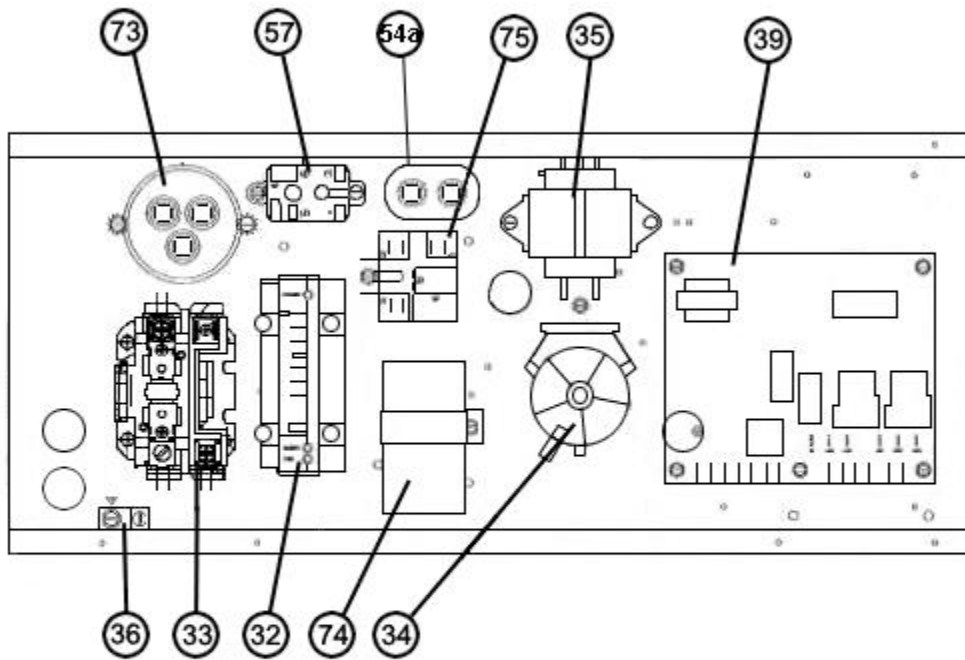

Electrical Control Box

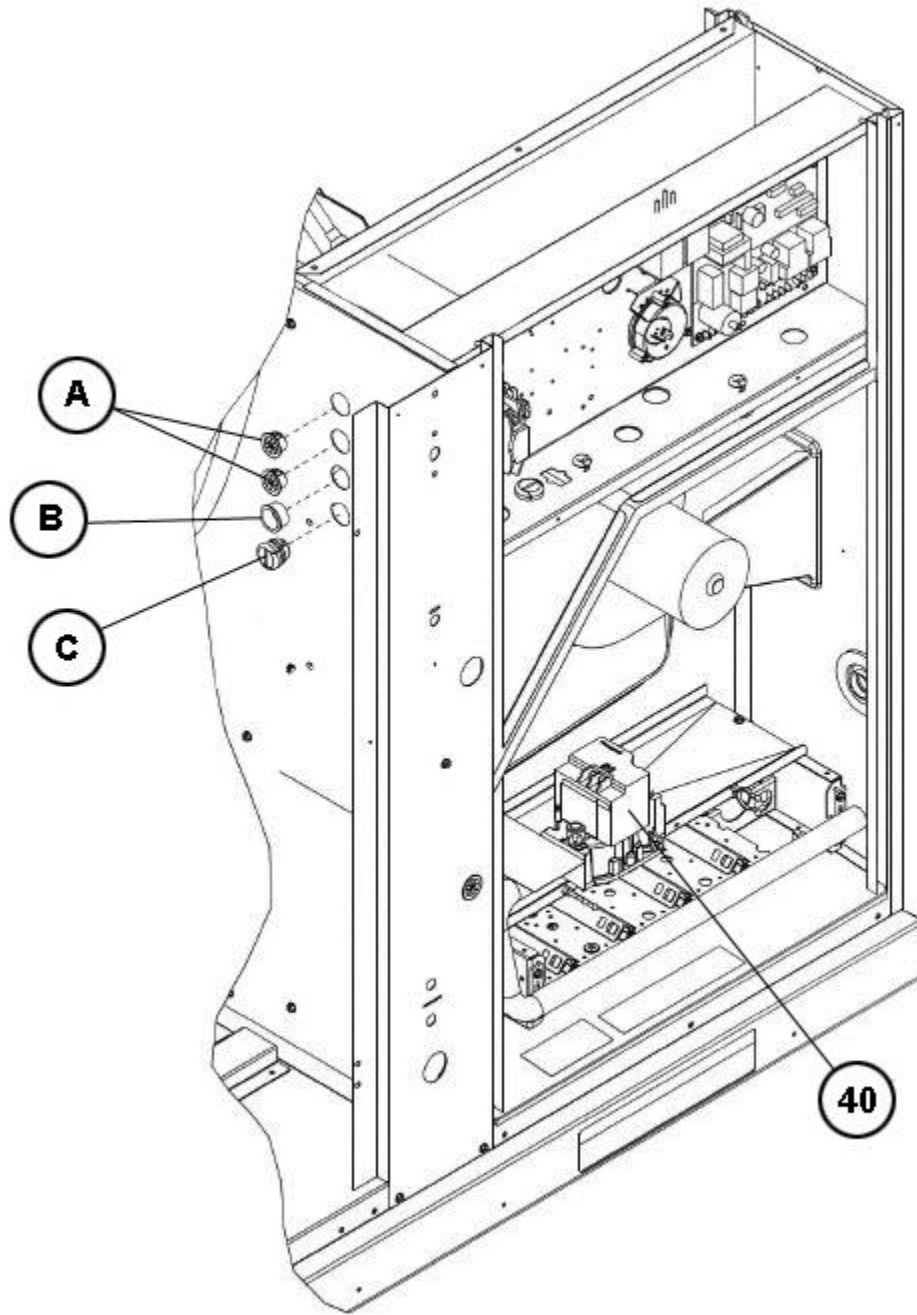

Bushings - Bulkhead Wiring

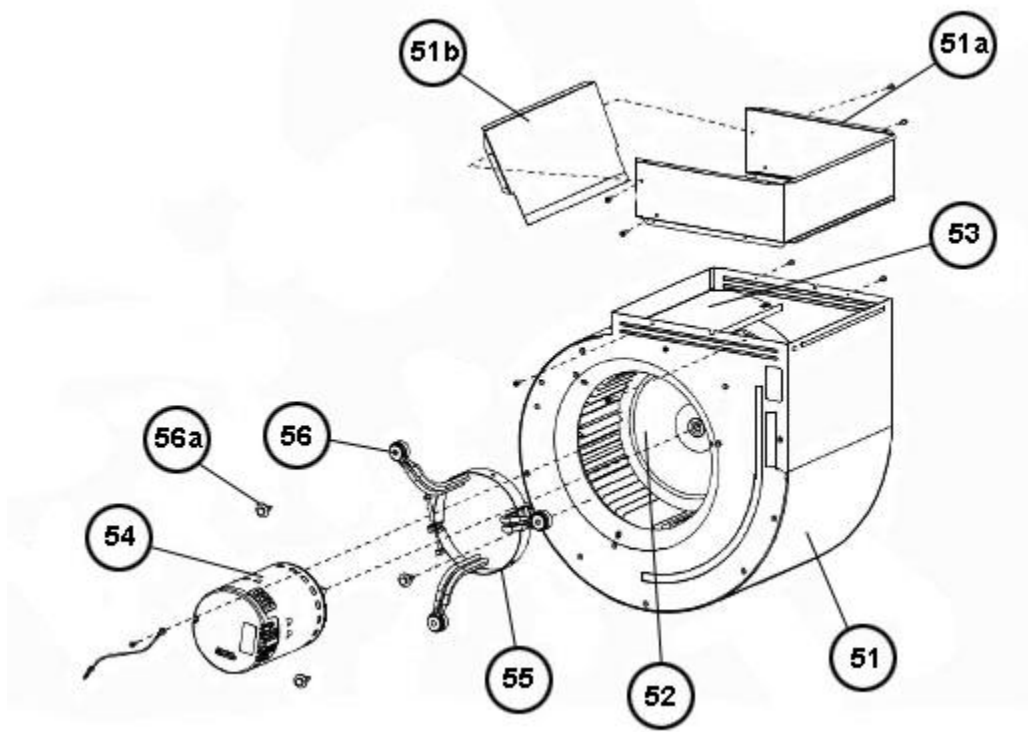

Blower Assembly

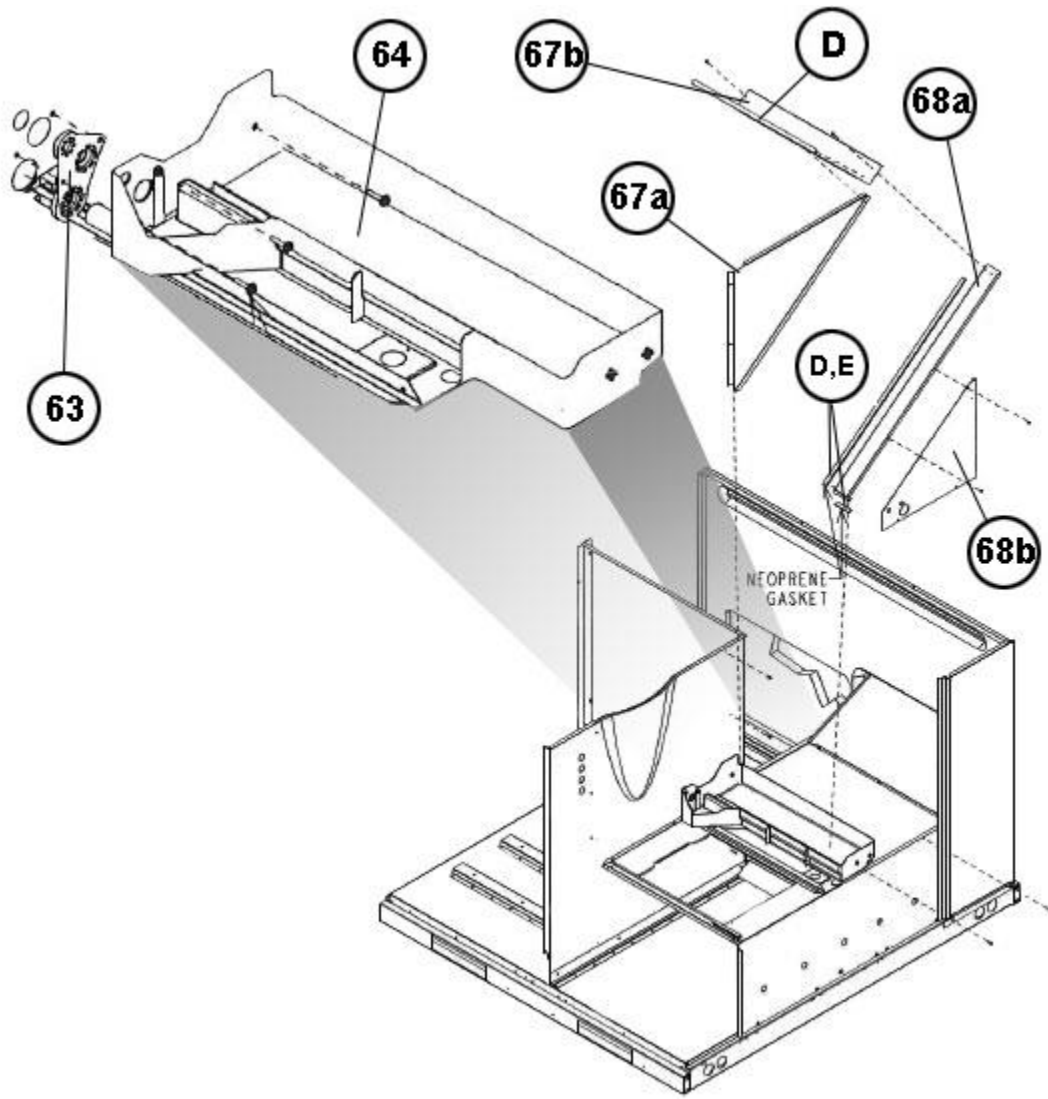

Coil Frames, Drainpan

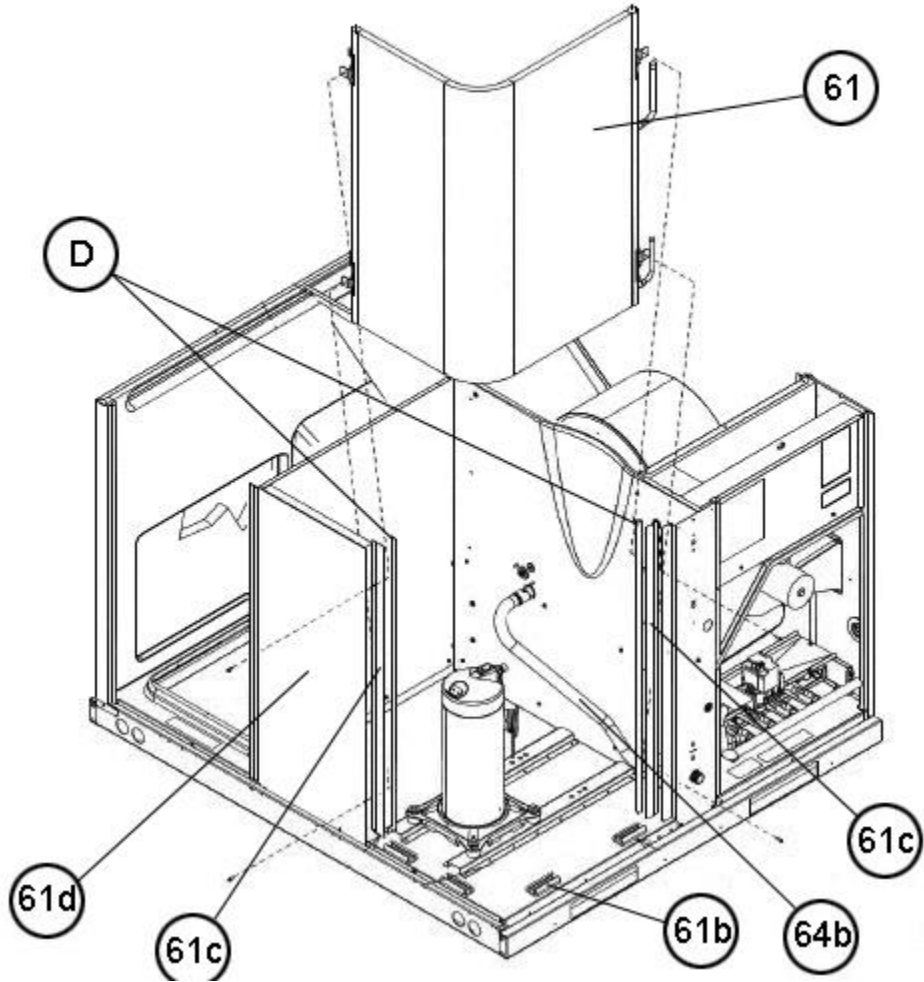

Condenser Coil 2 Ton

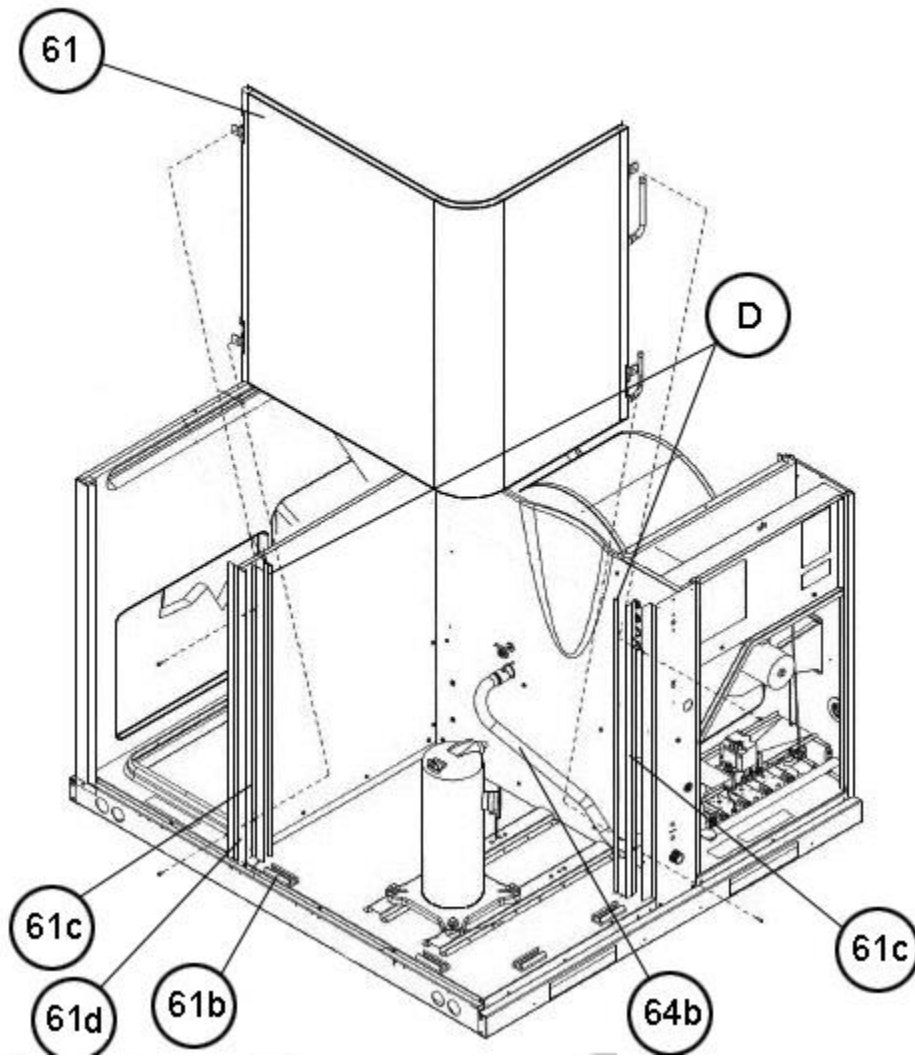

Condenser Coil 2.5 - 3 Ton

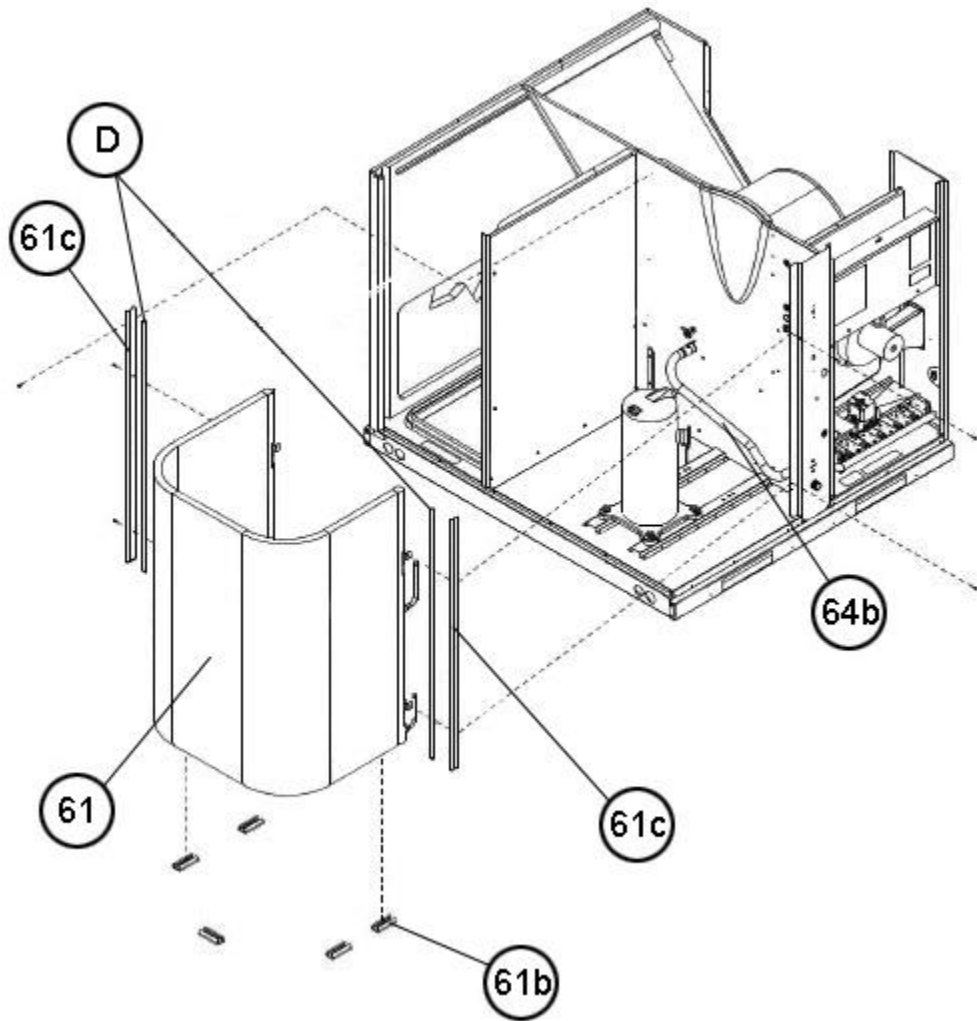

Condenser Coil 3.5 - 4 - 5 Ton

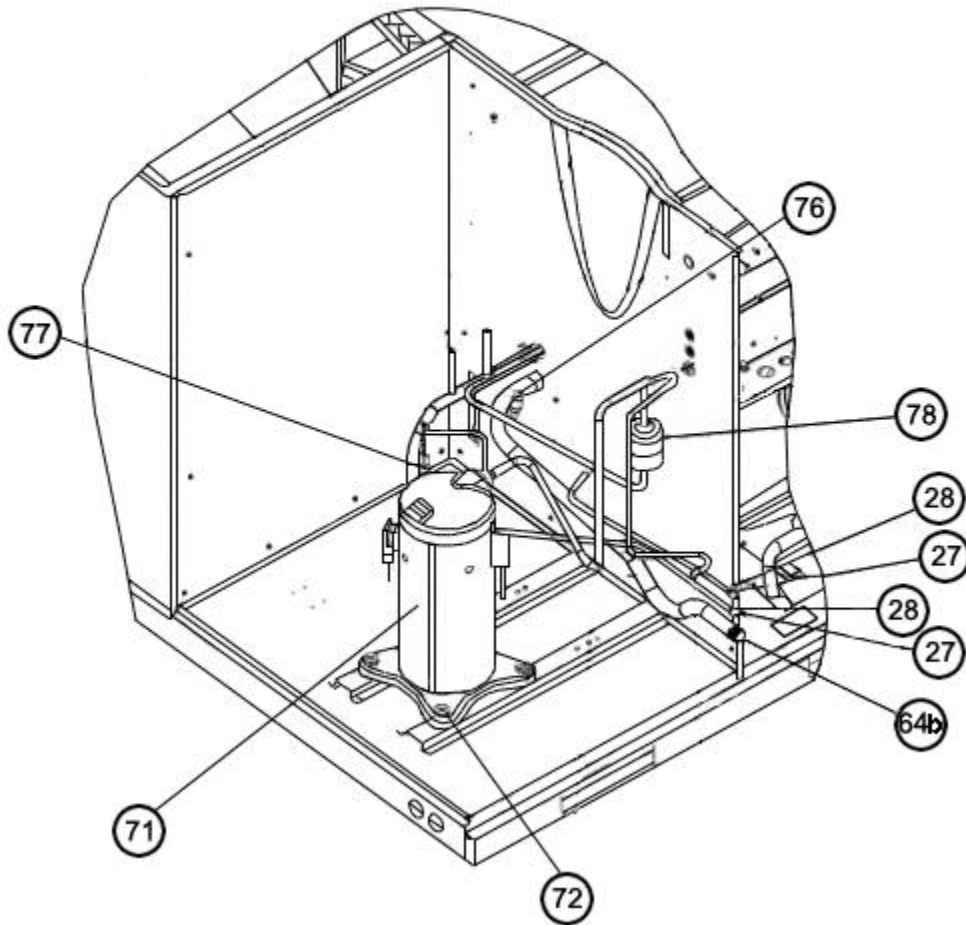

Compressor and Refrigeration Components

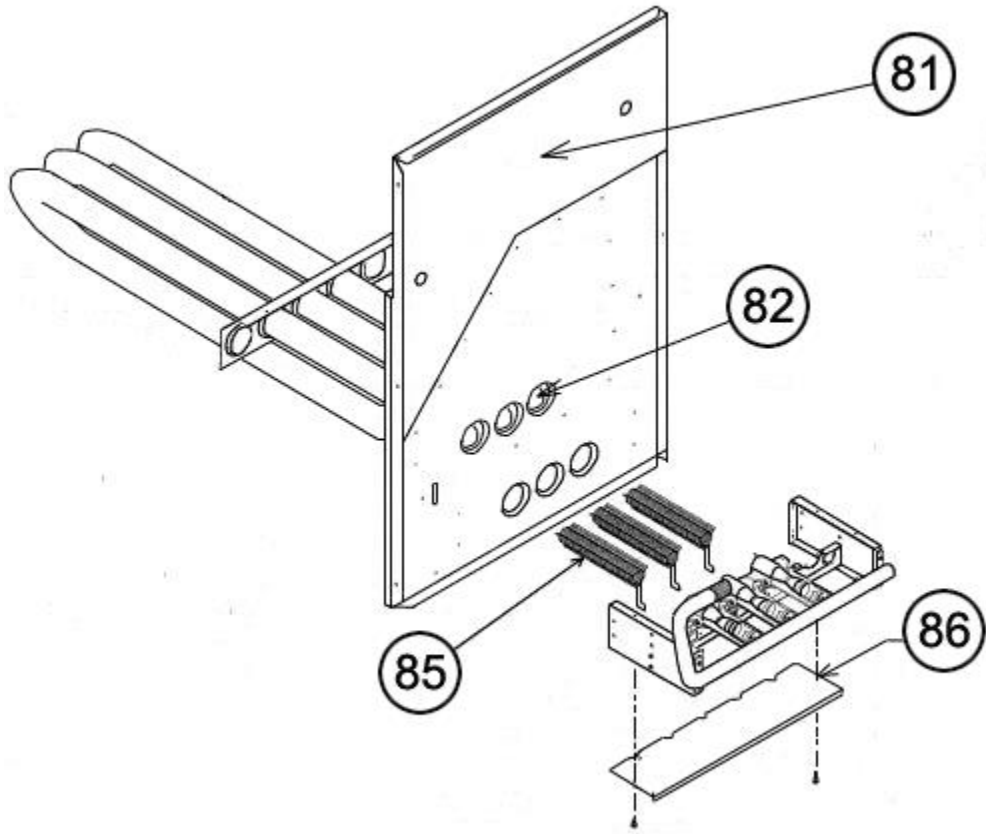

Heat Exchanger Assembly

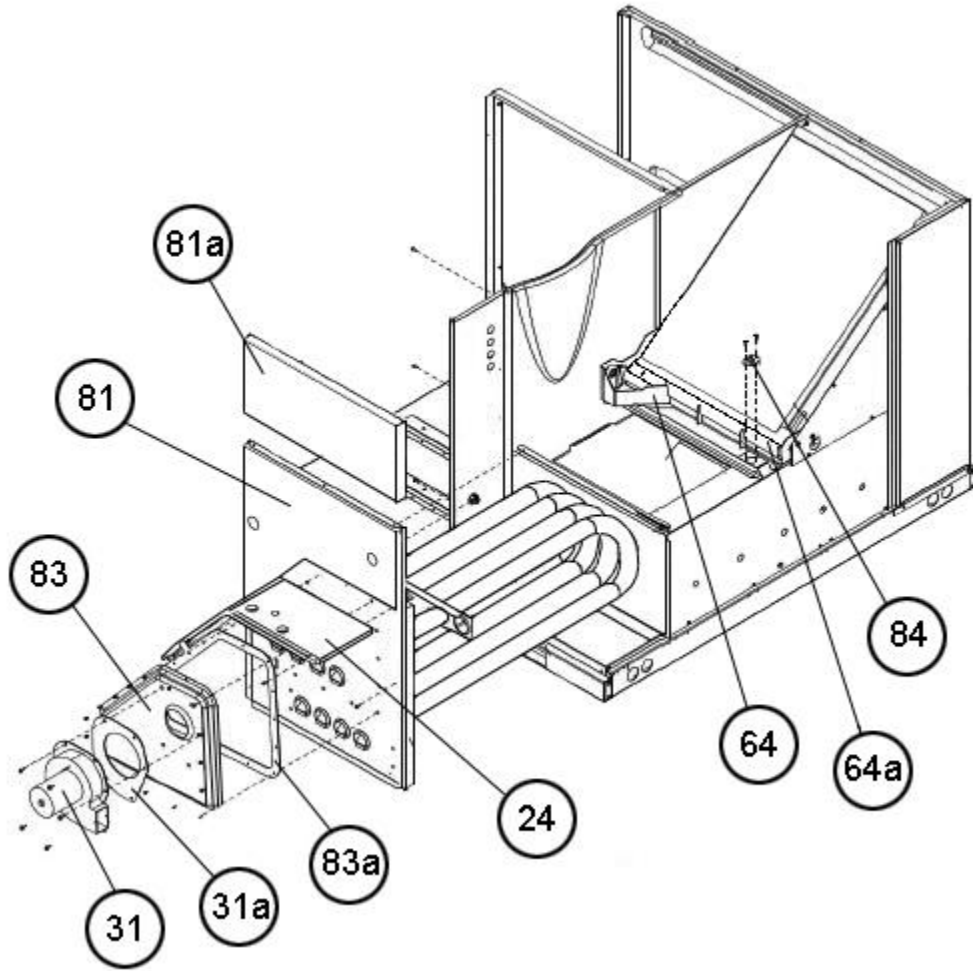

Collector Box - Heat Exchanger

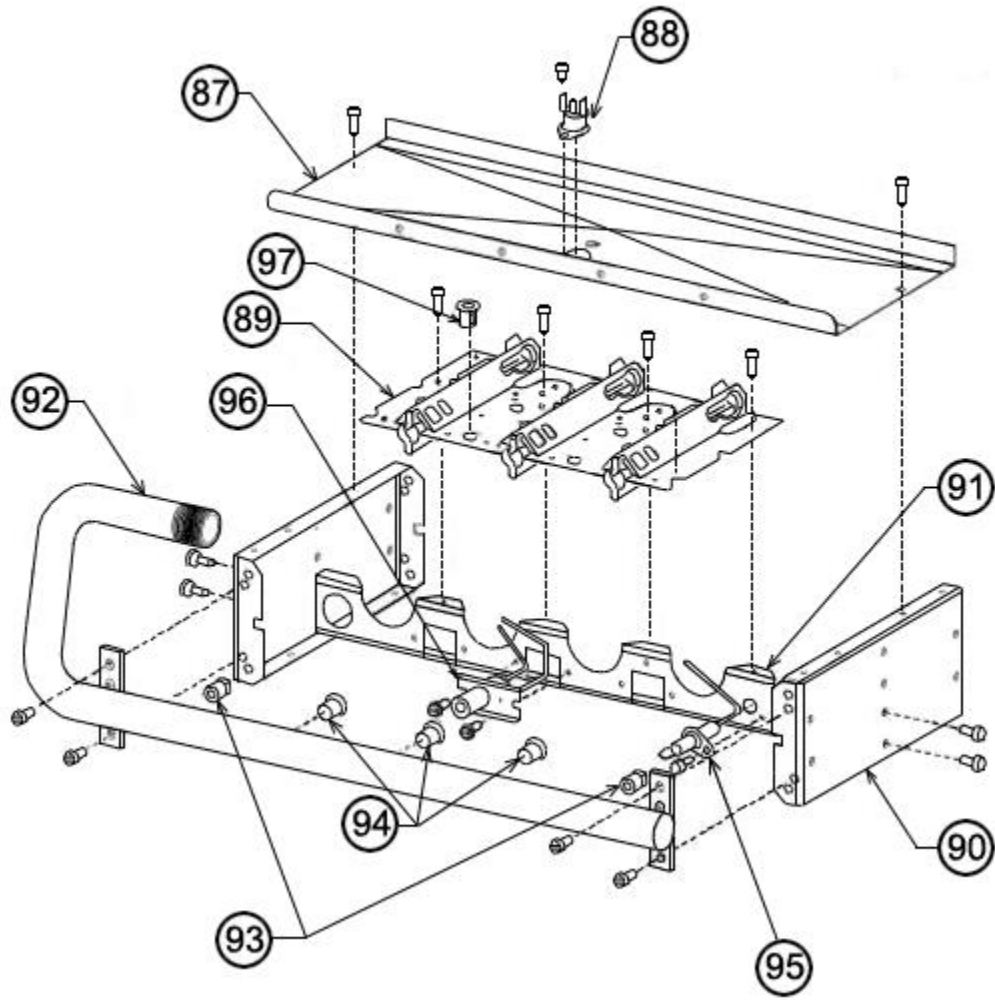

Burner Assembly

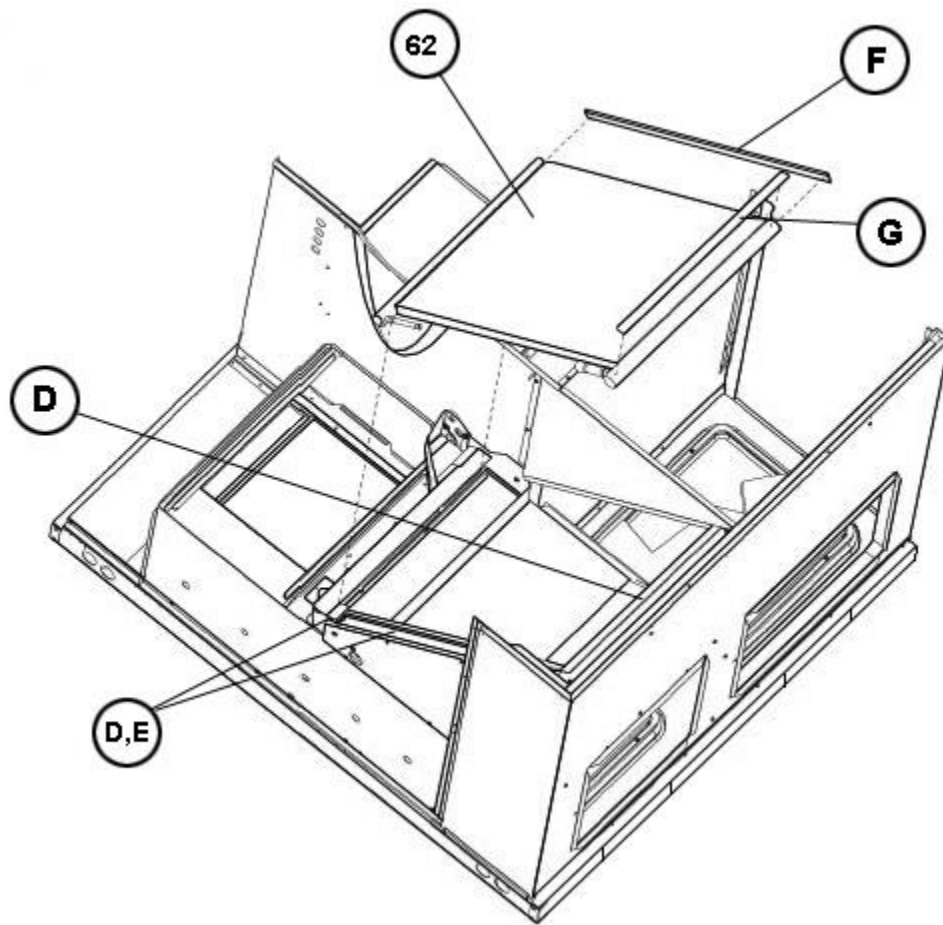

Evaporator Coil Gaskets

# NOTES

Stk It is recommended that stock be maintained for this part.

N/A Not Applicable

- 1 Order Gas Valve for Natural Gas along with LP Conversion Kit. (If the original valve has been replaced, order the spring kit for the replacement valve.)
- 2 The original factory installed gas valve used on the 2W gas code was the White-Rodgers [60-106207-01](#). The approved factory replacement has been identified as the Honeywell [60-105055-01](#). If you need a LP conversion for either of the [60-106207-01](#) or [60-105055-01](#) please order part number [EP-94D](#).

**DISCLAIMER:** This document is intended to provide general replacement parts information to aid qualified service personnel in the repair of these models. The complete Model and Serial Number of the unit under repair should be specified when selecting and ordering replacement parts. Specifications and illustrations are subject to change without notice. Document 92-42800-RGEA14 supersedes all previous parts lists for these models. See <http://www.rheempartslists.net/92-42800-RGEA14> for the latest revision of this document. The manufacturer assumes no obligation for errors or omissions. Service personnel must verify the proper and safe operation of equipment after the replacement of any original components.