

# INSTALLATION INSTRUCTIONS

## FOR 4 POSITION CONDENSING TWO-STAGE, COMMUNICATING GAS FURNACES W/ECM BLOWER

(-)96V SERIES

& (-)(-)96MDV SERIES

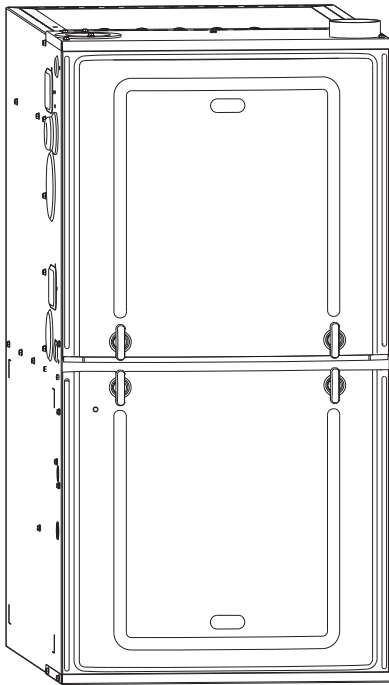

**RECOGNIZE THIS SYMBOL AS AN INDICATION OF IMPORTANT SAFETY INFORMATION!**

### ▲ WARNING

IF THE INFORMATION IN THESE INSTRUCTIONS IS NOT FOLLOWED EXACTLY, A FIRE OR EXPLOSION MAY RESULT, CAUSING PROPERTY DAMAGE, PERSONAL INJURY OR DEATH.

### ▲ WARNING

THESE INSTRUCTIONS ARE INTENDED AS AN AID TO QUALIFIED SERVICE PERSONNEL FOR PROPER INSTALLATION, ADJUSTMENT AND OPERATION OF THIS UNIT. READ THESE INSTRUCTIONS THOROUGHLY BEFORE ATTEMPTING INSTALLATION OR OPERATION. FAILURE TO FOLLOW THESE INSTRUCTIONS MAY RESULT IN IMPROPER INSTALLATION, ADJUSTMENT, SERVICE OR MAINTENANCE, POSSIBLY RESULTING IN FIRE, ELECTRICAL SHOCK, CARBON MONOXIDE POISONING, EXPLOSION, PROPERTY DAMAGE, PERSONAL INJURY OR DEATH.

### ▲ WARNING

**PROPOSITION 65 WARNING: THIS PRODUCT CONTAINS CHEMICALS KNOWN TO THE STATE OF CALIFORNIA TO CAUSE CANCER, BIRTH DEFECTS OR OTHER REPRODUCTIVE HARM.**

### ▲ WARNING

- Do not store or use gasoline or other flammable vapors and liquids, or other combustible materials in the vicinity of this or any other appliance.
- WHAT TO DO IF YOU SMELL GAS
  - Do not try to light any appliance.
  - Do not touch any electrical switch; do not use any phone in your building.
  - Immediately call your gas supplier from a neighbor's phone. Follow the gas supplier's instructions.
  - If you cannot reach your gas supplier, call the fire department.
  - Do not return to your home until authorized by the gas supplier or fire department.
- DO NOT RELY ON SMELL ALONE TO DETECT LEAKS. DUE TO VARIOUS FACTORS, YOU MAY NOT BE ABLE TO SMELL FUEL GASES.
  - U.L. and/or C.S.A. recognized fuel gas and CO (carbon monoxide) detectors are recommended in all applications, and their installation should be in accordance with the manufacturer's recommendations and/or local laws, rules, regulations, or customs.
- Improper installation, adjustment, alteration, service or maintenance can cause injury, property damage or death. Refer to this manual. Installation and service must be performed by a qualified installer, service agency or the gas supplier. In the commonwealth of Massachusetts, installation must be performed by a licensed plumber or gas fitter for appropriate fuel.

**DO NOT DESTROY THIS MANUAL. PLEASE READ CAREFULLY AND KEEP IN A SAFE PLACE FOR FUTURE REFERENCE BY A SERVICEMAN.**



← Factory Use Only

92-24161-124-03  
SUPERSEDES 92-24161-124-02

# TABLE OF CONTENTS

<b>1</b>	<b>TABLE OF CONTENTS</b> .....	<b>2</b>
<b>2</b>	<b>GENERAL INFORMATION</b> .....	<b>3</b>
	Receiving .....	4
	California Proposition 65 Note .....	4
	Checklist .....	5
<b>3</b>	<b>SAFETY INFORMATION</b> .....	<b>6</b>
	Warnings .....	6
	Important Information About Efficiency and Quality ..	7
	Commonwealth of Massachusetts Note .....	8
<b>4</b>	<b>LOCATION REQUIREMENTS</b> .....	<b>9</b>
	Freeze Protection .....	9
	Site Selection .....	10
	Clearance Accessibility .....	10
	Clearance Table .....	11
<b>5</b>	<b>FIELD CONVERSION</b> .....	<b>12</b>
	General Conversion Instructions and Tips .....	12
	Lists of Materials for Parts Bag and Conversion Kits .....	13
	Conversion Table of Contents .....	14
	Upflow with Vertical Vent .....	15-16
	Upflow with Left Side Vent .....	17-18
	Downflow with Right Vent (Non Zero Clearance) ..	19-22
	Downflow Zero-Clearance .....	23-27
	Horizontal Right with Right Vent .....	28-30
	Horizontal Right with Vertical Vent .....	31-33
	Horizontal Left with Right Vent .....	34-38
	Horizontal Left with Left Vent .....	39-41
<b>6</b>	<b>DUCTING</b> .....	<b>42</b>
<b>7</b>	<b>VENTING</b> .....	<b>45</b>
	General Venting Requirements and Guidelines (All Instructions) .....	45
	Venting and Combustion Air Piping Requirements .....	45
	Piping Requirements .....	46
	Vent Pipe Sizing and Maximum Lengths .....	48-49
	Equivalent Vent Length .....	48
	Polypropylene Vent Products .....	50
	Termination Requirements .....	51
	<b>Non-Direct Venting</b> .....	<b>52</b>
	Non-Direct Venting in an Unconfined Space .....	52
	Non-Direct Venting in a Confined Space .....	52
	Non-Direct Venting Terminations .....	55
	Non-Direct Venting Termination Clearances .....	57
	<b>Direct Venting</b> .....	<b>58</b>
	<u>Option 1</u> : Standard Vertical Direct Vent Termination .....	58
	<u>Option 2</u> : Standard Horizontal Direct Vent Termination .....	60
	<u>Option 3</u> : Variants of Standard Horizontal Direct Vent Termination .....	60
	<u>Option 4</u> : Alternate Horizontal Direct Vent Termination .....	61
	<u>Option 5</u> : Variants of Alternate Horizontal Direct Vent Termination .....	61
	Optional Termination Angles for Alt. Horizontal and Variant of Alt. Horizontal Direct-Vent Terminations (Options 4 and 5) ..	62
	<u>Option 6 &amp; 7</u> : Vertical and Horizontal Concentric Vent Termination (RXGY-E02A and RXGY-E03A) .....	63
	<u>Options 8 &amp; 9</u> : Sidewall Vent Kit for Direct Vent Termination (RXGY-G02 & RXGY-G01) .....	64
	Direct Venting Termination Clearances .....	65
	Multiventing of Direct Vent Furnaces .....	66
<b>8</b>	<b>CONDENSATE DRAIN AND DRAIN NEUTRALIZER</b> .....	<b>67</b>
<b>9</b>	<b>GAS SUPPLY AND PIPING</b> .....	<b>69</b>
	Gas Supply .....	69
	Gas Piping .....	70
	Gas Pressure .....	73
	Gas Valve .....	73
<b>10</b>	<b>LP CONVERSION</b> .....	<b>74</b>
<b>11</b>	<b>Setting the Gas Pressure</b> .....	<b>75</b>
<b>12</b>	<b>ELECTRICAL WIRING</b> .....	<b>76</b>
	Reversing the Electrical Connection .....	76
	Thermostat .....	77
<b>13</b>	<b>ACCESSORIES</b> .....	<b>78</b>
	Electronic Air Cleaner .....	78
	Humidifier .....	78
	Filter .....	78
<b>14</b>	<b>TWINNING (NOT PERMITTED)</b> .....	<b>78</b>
<b>15</b>	<b>HIGH ALTITUDE INSTALLATIONS</b> .....	<b>80</b>
	Natural Gas at High Altitudes .....	80
	LP Gas at High Altitudes .....	82
<b>16</b>	<b>STARTUP</b> .....	<b>83</b>
<b>17</b>	<b>SEQUENCE OF OPERATIONS</b> .....	<b>83</b>
<b>18</b>	<b>INTEGRATED FURNACE CONTROL</b> .....	<b>84</b>
<b>19</b>	<b>HUMIDIFICATION/DEHUMIDIFICATION</b> .....	<b>86</b>
<b>20</b>	<b>DIPSWITCHES</b> .....	<b>89</b>
<b>21</b>	<b>MODEL DATA CARD</b> .....	<b>92</b>
<b>22</b>	<b>DUAL 7-SEGMENT DISPLAY</b> .....	<b>92</b>
<b>23</b>	<b>PUSHBUTTON</b> .....	<b>95</b>
<b>24</b>	<b>SUPPLY &amp; OUTDOOR AIR TEMP SENSORS</b> .....	<b>97</b>
<b>25</b>	<b>AUXILIARY INPUTS</b> .....	<b>98</b>
<b>26</b>	<b>THERMOSTAT WIRING DIAGRAMS</b> .....	<b>99</b>
	Communicating .....	99
	Legacy (Non-Communicating) .....	101
<b>27</b>	<b>FUSE</b> .....	<b>102</b>
<b>28</b>	<b>TIMING DIAGRAM</b> .....	<b>103</b>
<b>29</b>	<b>ADJUSTING AND CHECKING FURNACE INPUT RATE</b> .....	<b>103</b>
<b>30</b>	<b>SETTING INPUT RATE</b> .....	<b>104</b>
<b>31</b>	<b>AIRFLOW</b> .....	<b>105</b>
<b>32</b>	<b>MAINTENANCE</b> .....	<b>106</b>
	Filters .....	106
	Lubrication .....	106
	Annual Inspection .....	107
<b>33</b>	<b>REPLACEMENT PARTS</b> .....	<b>107</b>
<b>34</b>	<b>DIAGNOSTICS AND TROUBLESHOOTING</b> .....	<b>108</b>
	Normal Operation Codes .....	108
	Fault Codes with Descriptions and Solutions .....	109
	Lockout .....	118
	Replacing the Furnace Control .....	118
	Diagnosing Blower Motor Issues .....	119
	Troubleshooting Chart .....	121
	Wiring Diagram .....	123

# GENERAL INFORMATION

**NOTE:** A heat loss calculation should be performed to properly determine the required furnace BTU size for the structure. Also, the duct must be properly designed and installed for proper airflow. Existing ductwork must be inspected for proper size and to make sure that it is properly sealed. Proper airflow is necessary for both user comfort and equipment performance.

**Before opening the furnace carton, verify that the data tags on the carton specify the furnace model number that was ordered from the distributor and are correct for the installation. If not, return the unit without opening the carton. If the model number is correct, open the carton and verify that the furnace rating label specifies the same furnace model number that is specified on the carton label. If the model numbers do not match, return the furnace to the distributor.**

**IMPORTANT:** Proper application, installation and maintenance of this furnace and system is a must if consumers are to receive the full benefits for which they have paid.

The (-)96V and (-)(-)96MDV series furnaces are design-certified by CSA for use with natural and propane gases as follows:

1. As non-direct vent central forced air furnaces taking combustion air from the installation area or using air ducted from the outside.
2. As direct vent central forced air furnaces with all combustion air supplied directly to the furnace burners through a special air intake system outlined in these instructions. Install this furnace in accordance with the American National Standard Z223.1 – latest edition entitled “National Fuel Gas Code” (NFPA54) or, for Canada, CSA B149.1; Canadian Natural Gas and Propane Installation Code and requirements or codes of the local utilities or other authorities having jurisdiction. This is available from the following:

National Fire Protection Association, Inc.  
 Batterymarch Park  
 Quincy, MA 02269

CSA-INTERNATIONAL  
 5060 Spectrum Way  
 Mississauga, Ontario  
 Canada L4W5N6  
 Online: www.csa.ca

**FIGURE 1  
 FURNACE COMPONENTS**

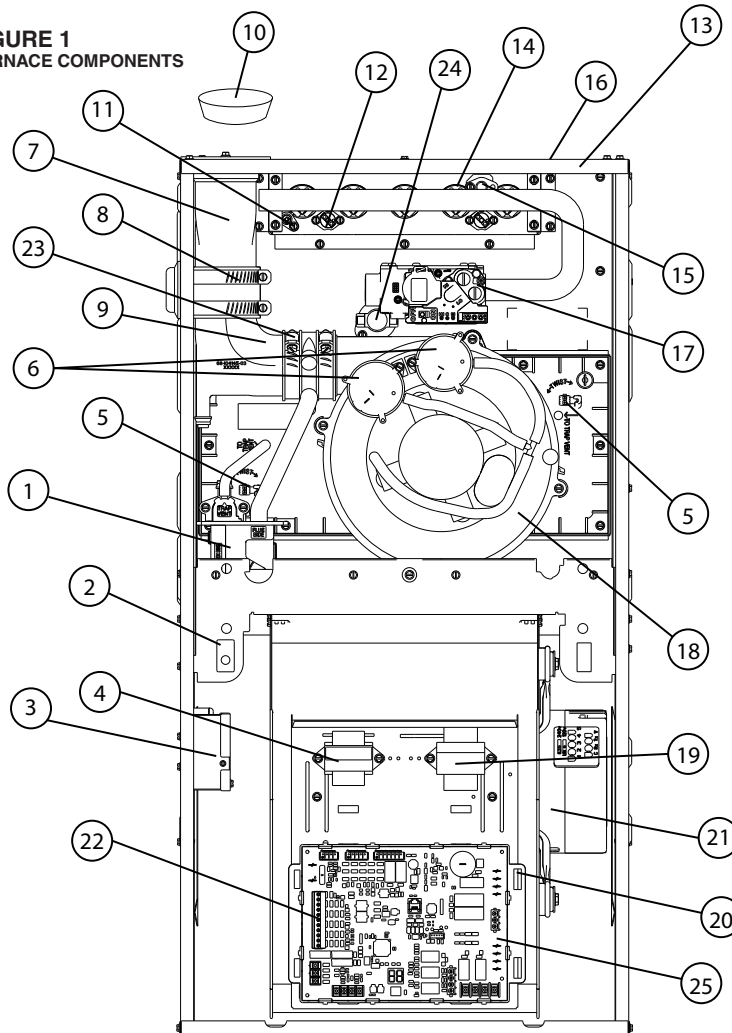

ITEM NO.	DESCRIPTION
1	CONDENSATE TRAP
2	DOOR SWITCH
3	JUNCTION BOX
4	TRANSFORMER
5	WATER SENSOR (2)
6	PRESSURE SWITCHES, HIGH & LOW STAGE
7	EXHAUST TRANSITION
8	COUPLING (ELBOW TO TRANSITION)
9	EXHAUST
10	SHIPPING PLUG
11	FLAME SENSOR
12	OVER TEMPERATURE SWITCH
13	TOP PLATE
14	BURNER
15	IGNITER
16	COMBUSTION AIR INLET
17	GAS VALVE
18	INDUCED DRAFT BLOWER (IDB)
19	POWER FACTOR CORRECTION CHOKE (PFC) (EXCEPT 56KBTU AND 70KBTU)
20	CONTROL MOUNTING PLATE
21	BLOWER
22	LOW VOLTAGE TERMINAL
23	COUPLING (IDB TO ELBOW)
24	FURNACE CONTROL
25	

ST-A1205-01

# GENERAL INFORMATION (cont.)

In Canada installations must comply with CSA B149.1.

Install units in Canada in accordance with CSA-B149, local installation codes and authorities having jurisdiction. CSA-B149.1 is available from:

CSA INTERNATIONAL  
5060 Spectrum Way  
Mississauga, Ontario  
Canada L4W 5N6

online: [www.csa.ca](http://www.csa.ca)

**NOTICE:** Any equipment immersed in water (including by flooding) must be replaced. Equipment and products immersed in water will have operation adversely affected thereby voiding the warranty.

## RECEIVING

Immediately upon receipt, all cartons and contents should be inspected for transit damage. Units with damaged cartons should be opened immediately. If damage is found, it should be noted on the delivery papers, and a damage claim filed with the last carrier.

- After unit has been delivered to job site, remove carton taking care not to damage unit.
- Check the unit rating plate to be sure equipment matches job specifications.
- Read the entire instructions before starting the installation.
- Install the unit in such a way as to allow necessary access for service.
- Always remove the solid metal base pan from the top of the furnace. The base pan is installed in this location for shipping purposes only and should never remain in the as-shipped location after installation.
- Install the unit with a 1/4" to 1/2" forward slope (toward front) to ensure proper drainage.
- Install the unit in accordance with any local code which may apply and the national codes. Latest editions are available from: "National Fire Protection Association, Inc., Batterymarch Park, Quincy, MA 02269." These publications are:
  - ANSI/NFPA No. 70-(Latest Edition) National Electrical Code.
  - NFPA90A Installation of Air Conditioning and Ventilating Systems.
  - NFPA90B Installation of warm air heating and air conditioning systems.
  - In Canada CSA 22.2 Canadian Electrical Code.
  - In Canada CSA B149.1; Canadian Natural Gas and Propane Installation Code.

## CALIFORNIA RESIDENTS ONLY

**IMPORTANT:** All manufacturer products meet current Federal OSHA Guidelines for safety. California Proposition 65 warnings are required for certain products, which are not covered by the OSHA standards.

California's Proposition 65 requires warnings for products sold in California that contain, or produce, any of over 600 listed chemicals known to the State of California to cause cancer or birth defects such as fiberglass insulation, lead in brass, and combustion products from natural gas.

All "new equipment" shipped for sale in California will have labels stating that the product contains and/or produces Proposition 65 chemicals. Although we have not changed our processes, having the same label on all our products facilitates manufacturing and shipping. We cannot always know "when, or if" products will be sold in the California market.

You may receive inquiries from customers about chemicals found in, or produced by, some of our heating and air-conditioning equipment, or found in natural gas used with some of our products. Listed below are those chemicals and substances commonly associated with similar equipment in our industry and other manufacturers.

- Glass Wool (Fiberglass) Insulation
- Carbon Monoxide (CO)
- Formaldehyde
- Benzene

More details are available at the Websites for OSHA (Occupational Safety and Health Administration), at [www.osha.gov](http://www.osha.gov) and the State of California's OEHHA (Office of Environmental Health Hazard Assessment), at [www.oehha.org](http://www.oehha.org). Consumer education is important since the chemicals and substances on the list are found in our daily lives. Most consumers are aware that products present safety and health risks, when improperly used, handled and maintained.

**Installation Instructions remain with the furnace as a reference guide to the servicing contractor. We recommend that performance and installation data be recorded for future reference on this sheet to meet service and warranty obligations so that job site information is available when required.**

## Installation Checklist

REFER TO INSTALLATION INSTRUCTIONS

### GAS SUPPLY

- \_\_\_\_\_ Correct pipe size (record size)
- \_\_\_\_\_ Correct supply pressure (during furnace operation) (record pressure)
- \_\_\_\_\_ Manifold pressure (record upstream pressure)
- \_\_\_\_\_ No gas leaks
- \_\_\_\_\_ L.P. Kit Number (if applicable) (record kit number)

### ELECTRICAL

- \_\_\_\_\_ 115 V.A.C. supply (Dedicated Circuit) (record voltage)
- \_\_\_\_\_ Polarity observed
- \_\_\_\_\_ Furnace properly grounded
- \_\_\_\_\_ Correct wire size (record type and gauge)

### FURNACE INSTALLATION

- \_\_\_\_\_ Correct clearance to combustibles (record clearance)
- \_\_\_\_\_ Correct clearance for service (at front) (record clearance)

### DUCT STATIC PRESSURE

- \_\_\_\_\_ in. w.c. on heating speed (record static pressure)
- \_\_\_\_\_ in. w.c. on cooling speed (record static pressure)
- \_\_\_\_\_ Air temperature rise in heat (record air temperature rise)
- \_\_\_\_\_ Air temperature rise in cool (record air temperature rise)

### CONDENSATE LINE

- \_\_\_\_\_ Trap filled with water
- \_\_\_\_\_ Vented
- \_\_\_\_\_ Sloped toward drain
- \_\_\_\_\_ Condensate drain line hoses connected and clamped
- \_\_\_\_\_ Freeze protection (if necessary)

### VENTING – DIRECT VENT

- \_\_\_\_\_ in. diameter – intake pipe (record diameter)
- \_\_\_\_\_ in. diameter – exhaust pipe (record diameter)
- \_\_\_\_\_ ft. of pipe – intake air (record length)
- \_\_\_\_\_ no. of elbows – intake air (record number of elbows)

- \_\_\_\_\_ ft. of pipe – exhaust pipe (record length)
- \_\_\_\_\_ no. of elbows – exhaust pipe (record number of elbows)
- \_\_\_\_\_ Exhaust Vent Temperature (record temperature)

### TERMINATIONS – DIRECT VENT

#### VERTICAL

- \_\_\_\_\_ Intake – 12" [305mm] min. above roof/snow level (record height above anticipated snow level) or, in Canada, intake and exhaust vents conform with CSA B149.1; Canadian Natural Gas and Propane Installation Code
- \_\_\_\_\_ Correct relationship – exhaust to intake

#### HORIZONTAL/VERTICAL – CONCENTRIC (RXGY-E03A)

- \_\_\_\_\_ Intake – 12" [305mm] min. above roof/snow level (record height above anticipated snow level) or, in Canada, intake and exhaust vents conform with CSA B149.1; Canadian Natural Gas and Propane Installation Code
- \_\_\_\_\_ Exhaust sloped down toward furnace
- \_\_\_\_\_ Correct distances (horizontal and vertical) – exhaust to intake
- \_\_\_\_\_ 12" [305mm] min. above grade/snow level (record height above anticipated snow level) or, in Canada, intake and exhaust vents conform with CSA B149.1; Canadian Natural Gas and Propane Installation Code
- \_\_\_\_\_ Above anticipated snow level (record maximum anticipated snow level)

### VENTING – NON-DIRECT VENT

- \_\_\_\_\_ in. diameter – exhaust pipe (record diameter)
- \_\_\_\_\_ ft. of pipe – exhaust (record length)
- \_\_\_\_\_ no. of elbows (record number of elbows)

### TERMINATION – NON-DIRECT VENT

#### VERTICAL

- \_\_\_\_\_ 12" [305mm] min. above roof/snow level (record height above anticipated snow level) or, in Canada, intake and exhaust vents conform with CSA B149.1; Canadian Natural Gas and Propane Installation Code

#### HORIZONTAL – STANDARD

- \_\_\_\_\_ 12" [305mm] min. above grade/snow level (record height above anticipated snow level) or, in Canada, intake and exhaust vents conform with CSA B149.1; Canadian Natural Gas and Propane Installation Code

# SAFETY INFORMATION

## WARNING

DO NOT INSTALL THIS FURNACE IN A MOBILE HOME!! THIS FURNACE IS NOT APPROVED FOR INSTALLATION IN A MOBILE HOME. DOING SO COULD CAUSE FIRE, PROPERTY DAMAGE, PERSONAL INJURY OR DEATH.

## WARNING

INSTALL THIS FURNACE ONLY IN A LOCATION AND POSITION AS SPECIFIED IN THE LOCATION REQUIREMENTS AND CONSIDERATIONS SECTION OF THESE INSTRUCTIONS.

## WARNING

IMPROPER INSTALLATION, OR INSTALLATION NOT MADE IN ACCORDANCE WITH THE CSA INTERNATIONAL (CSA) CERTIFICATION OR THESE INSTRUCTIONS, CAN RESULT IN UNSATISFACTORY OPERATION AND/OR DANGEROUS CONDITIONS AND ARE NOT COVERED BY THE MANUFACTURER'S WARRANTY.

## WARNING

DO NOT BYPASS, JUMPER, OR REMOVE ANY SAFETY SWITCH FROM THE FURNACE CONTROL CIRCUIT. IF A SAFETY SWITCH CAUSES THE FURNACE TO SHUT DOWN OR OPERATE INTERMITTENTLY, IT IS AN INDICATION OF A POTENTIAL SAFETY HAZARD THAT MUST BE ADDRESSED BY A QUALIFIED TECHNICIAN, SERVICE AGENCY OR THE GAS SUPPLIER. DO NOT RESET SAFETY CONTROLS WITHOUT CORRECTIVE ACTION AND/OR VERIFICATION OF PROPER SAFE OPERATION BY A QUALIFIED INSTALLER, SERVICE AGENCY OR THE GAS SUPPLIER.

REPLACE ANY SAFETY CONTROL COMPONENT ONLY WITH IDENTICAL OEM REPLACEMENT PARTS. WHEN A NEW SAFETY SWITCH IS INSTALLED, IT MUST BE TESTED FOR A MINIMUM OF 15 MINUTES WITH THE FURNACE OPERATING AT MAXIMUM INPUT RATE AND WITH BOTH BLOWER AND BURNER DOOR INSTALLED. IF THE FURNACE IS INSTALLED IN A CLOSET, THE CLOSET DOOR MUST ALSO BE CLOSED FOR THIS TEST. REPEAT THE TEST AT THE MINIMUM INPUT RATE IF THE FURNACE IS A MULTI-STAGE FURNACE.

## WARNING

USE ONLY WITH THE TYPE OF GAS APPROVED FOR THIS FURNACE. REFER TO THE FURNACE RATING PLATE.

## WARNING

NEVER TEST FOR GAS LEAKS WITH AN OPEN FLAME. USE A COMMERCIALY AVAILABLE SOAP SOLUTION MADE SPECIFICALLY FOR THE DETECTION OF LEAKS TO CHECK ALL CONNECTIONS, AS SPECIFIED IN GAS SUPPLY AND PIPING SECTION OF THESE INSTRUCTIONS.

## WARNING

COMBUSTION AND VENTILATION AIR MUST BE PROVIDED TO THE FURNACE AS REQUIRED BY THE NATIONAL FUEL-GAS CODE (U.S.) AND CSA B149.1 (CANADA) AND THE COMBUSTION AND VENTILATION AIR SECTION OF THESE INSTRUCTIONS.

## WARNING

COMBUSTION PRODUCTS MUST BE DISCHARGED OUTDOORS. CONNECT THIS FURNACE TO AN APPROVED VENT SYSTEM ONLY, AS SPECIFIED IN THE VENT PIPE INSTALLATION SECTION OF THESE INSTRUCTIONS.

## WARNING

WHEN A FURNACE IS INSTALLED SO THAT SUPPLY DUCTS CARRY AIR CIRCULATED BY THE FURNACE TO AREAS OUTSIDE THE SPACE CONTAINING THE FURNACE, THE RETURN AIR SHALL ALSO BE HANDLED BY DUCT(S) SEALED TO THE FURNACE CASING AND TERMINATING OUTSIDE THE SPACE CONTAINING THE FURNACE.

## WARNING

WHENEVER THE FACTORY RETURN-AIR CONNECTION IS NOT USED IT MUST BE SEALED. A SOLID METAL BASE PLATE MUST BE INSTALLED AND SEALED. FACTORY BASE PLATES ARE AVAILABLE AS ACCESSORY ITEMS. (PART NUMBERS ARE LISTED IN THE SPEC SHEET FOR THE FURNACE.) FAILURE TO INSTALL AND SEAL THE BASE PLATE AND RETURN AIR DUCT CONNECTIONS MAY ALLOW CARBON MONOXIDE AND OTHER CONTAMINANTS TO BE DRAWN INTO THE CONDITIONED AIR SPACE AND DISTRIBUTED THROUGHOUT THE HEATED SPACE.

## WARNING

DO NOT OPERATE THE SYSTEM WITHOUT FILTERS. A PORTION OF THE DUST ENTRAINED IN THE AIR MAY TEMPORARILY LODGE IN THE AIR DUCT RUNS AND AT THE SUPPLY REGISTERS. ANY CIRCULATED DUST PARTICLES WILL BE HEATED AND CHARRED BY CONTACT WITH THE FURNACE HEAT EXCHANGER. THIS SOOTY RESIDUE WILL SOIL CEILINGS, WALLS, DRAPES, CARPETS AND OTHER HOUSEHOLD ARTICLES. SOOT DAMAGE MAY ALSO RESULT WITH, OR WITHOUT, FILTERS IN PLACE, WHEN CERTAIN TYPES OF CANDLES ARE BURNED, OR CANDLEWICKS ARE LEFT UNTRIMMED.

## WARNING

IN COMPLIANCE WITH RECOGNIZED CODES, IT IS RECOMMENDED THAT AN AUXILIARY DRAIN PAN BE INSTALLED UNDER THIS FURNACE AND ANY INSTALLED EVAPORATOR COIL THAT IS LOCATED IN ANY AREA OF A STRUCTURE WHERE DAMAGE TO THE BUILDING OR BUILDING CONTENTS MAY OCCUR AS A RESULT OF AN OVERFLOW OF THE FURNACE CONDENSATE DISPOSAL SYSTEM OR THE COIL DRAIN PAN OR A STOPPAGE IN THE PRIMARY CONDENSATE DRAIN PIPING.

# SAFETY

## **⚠ WARNING**

ALWAYS INSTALL THE FURNACE TO OPERATE WITHIN THE FURNACE'S INTENDED TEMPERATURE-RISE RANGE WITH A DUCT SYSTEM WHICH HAS AN EXTERNAL STATIC PRESSURE WITHIN THE ALLOWABLE RANGE, AS SPECIFIED IN THE DUCTING SECTION OF THESE INSTRUCTIONS. SEE ALSO FURNACE RATING PLATE.

THE FURNACE MAY BE USED FOR HEATING OF BUILDINGS OR STRUCTURES UNDER CONSTRUCTION.

INSTALLATION MUST COMPLY WITH ALL INSTALLATION INSTRUCTIONS INCLUDING:

- PROPER VENT INSTALLATION;
- FURNACE OPERATING UNDER THERMOSTAT CONTROL;
- RETURN AIR DUCT SEALED TO THE FURNACE; AIR FILTERS IN PLACE;
- SET FURNACE INPUT RATE AND TEMPERATURE RISE PER RATING PLATE MARKINGS;
- MEANS FOR PROVIDING OUTDOOR AIR REQUIRED FOR COMBUSTION;
- RETURN AIR TEMPERATURE MAINTAINED BETWEEN 55°F (13°C) AND 80°F (27°C); AND
- CLEAN FURNACE, DUCT WORK AND COMPONENTS UPON SUBSTANTIAL COMPLETION OF THE CONSTRUCTION PROCESS, AND VERIFY THAT THE FURNACE OPERATING CONDITIONS INCLUDING IGNITION, INPUT RATE, TEMPERATURE RISE AND VENTING, ACCORDING TO THE INSTRUCTIONS AND CODES.

## **⚠ WARNING**

DUCT LEAKS CAN CREATE AN UNBALANCED SYSTEM AND DRAW POLLUTANTS SUCH AS DIRT, DUST, FUMES AND ODORS INTO THE HOME CAUSING PROPERTY DAMAGE. FUMES AND ODORS FROM TOXIC, VOLATILE OR FLAMMABLE CHEMICALS, AS WELL AS AUTOMOBILE EXHAUST AND CARBON MONOXIDE (CO), CAN BE DRAWN INTO THE LIVING SPACE THROUGH LEAKING DUCTS AND UNBALANCED DUCT SYSTEMS CAUSING PERSONAL INJURY OR DEATH (SEE FIGURE 2).

- IF AIR-MOVING EQUIPMENT OR DUCTWORK IS LOCATED IN GARAGES OR OFF-GARAGE STORAGE AREAS - ALL JOINTS, SEAMS, AND OPENINGS IN THE EQUIPMENT AND DUCT MUST BE SEALED TO LIMIT THE MIGRATION OF TOXIC FUMES AND ODORS INCLUDING CARBON MONOXIDE FROM MIGRATING INTO THE LIVING SPACE.
- IF AIR-MOVING EQUIPMENT OR DUCTWORK IS LOCATED IN SPACES CONTAINING FUEL BURNING APPLIANCES SUCH AS WATER HEATERS OR BOILERS - ALL JOINTS, SEAMS, AND OPENINGS IN THE EQUIPMENT AND DUCT MUST ALSO BE SEALED TO PREVENT DEPRESSURIZATION OF THE SPACE AND POSSIBLE MIGRATION OF COMBUSTION BYPRODUCTS INCLUDING CARBON MONOXIDE INTO THE LIVING SPACE.

## IMPORTANT INFORMATION ABOUT EFFICIENCY AND INDOOR AIR QUALITY

Central cooling and heating equipment is only as efficient as the duct system that carries the cooled or heated air. To maintain efficiency, comfort and good indoor air quality, it is important to have the proper balance between the air supplied to each room and the air returning to the cooling and heating equipment.

Proper balance and sealing of the duct system improves the efficiency of the heating and air conditioning system and improves the indoor air quality of the home by reducing the amount of airborne pollutants that enter homes from spaces where the ductwork and / or equipment is located. The manufacturer and the U.S. Environmental Protection Agency's Energy Star Program recommend that central duct systems be checked by a qualified contractor for proper balance and sealing.

**FIGURE 2**  
MIGRATION OF DANGEROUS SUBSTANCES, FUMES, AND ODORS INTO LIVING SPACES

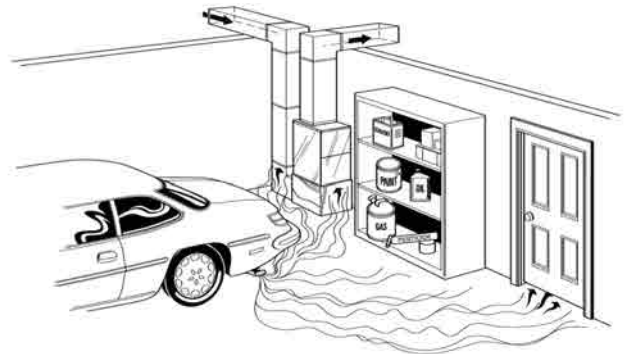

Adapted from *Residential Duct Diagnostics and Repair*, with permission of Air Conditioning Contractors of America (ACCA).

# COMMONWEALTH OF MASSACHUSETTS NOTE

## **IMPORTANT! THE COMMONWEALTH OF MASSACHUSETTS REQUIRES COMPLIANCE WITH REGULATION 248 CMR 4.00 AND 5.00 FOR INSTALLATION OF THROUGH-THE-WALL VENTED GAS APPLIANCES AS FOLLOWS:**

(a) For all side wall horizontally vented gas fueled equipment installed in every dwelling, building or structure used in whole or in part for residential purposes, including those owned or operated by the Commonwealth and where the side wall exhaust vent termination is less than seven (7) feet above finished grade in the area of the venting, including but not limited to decks and porches, the following requirements shall be satisfied:

**1. INSTALLATION OF CARBON MONOXIDE DETECTORS.** At the time of installation of the side wall horizontal vented gas fueled equipment, the installing plumber or gasfitter shall observe that a hard wired carbon monoxide detector with an alarm and battery back-up is installed on the floor level where the gas equipment is to be installed. In addition, the installing plumber or gasfitter shall observe that a battery operated or hard wired carbon monoxide detector with an alarm is installed on each additional level of the dwelling, building or structure served by the side wall horizontal vented gas fueled equipment. It shall be the responsibility of the property owner to secure the services of qualified licensed professionals for the installation of hard wired carbon monoxide detectors.

a. In the event that the side wall horizontally vented gas fueled equipment is installed in a crawl space or an attic, the hard wired carbon monoxide detector with alarm and battery back-up may be installed on the next adjacent floor level.

b. In the event that the requirements of this subdivision can not be met at the time of completion of installation, the owner shall have a period of thirty (30) days to comply with the above requirements; provided, however, that during said thirty (30) day period, a battery operated carbon monoxide detector with an alarm shall be installed.

**2. APPROVED CARBON MONOXIDE DETECTORS.** Each carbon monoxide detector as required in accordance with the above provisions shall comply with NFPA 720 and be ANSI/UL 2034 listed and IAS certified.

**3. SIGNAGE.** A metal or plastic identification plate shall be permanently mounted to the exterior of the building at a minimum height of eight (8) feet above grade directly in line with the exhaust vent terminal for the horizontally vented gas fueled heating appliance or equipment. The sign shall read, in print size no less than one-half (1/2) inch in size, **“GAS VENT DIRECTLY BELOW. KEEP CLEAR OF ALL OBSTRUCTIONS”**.

**4. INSPECTION.** The state or local gas inspector of the side wall horizontally vented gas fueled equipment shall not approve the installation unless, upon inspection, the inspector observes carbon monoxide detectors and signage installed in accordance with the provisions of 248 CMR 5.08(2)(a) 1 through 4.

(b) **EXEMPTIONS:** The following equipment is exempt from 248 CMR 5.08(2)(a)1 through 4:

1. The equipment listed in Chapter 10 entitled “Equipment Not Required To Be Vented” in the most current edition of NFPA 54 as adopted by the Board; and

2. Product Approved side wall horizontally vented gas fueled equipment installed in a room or structure separate from the dwelling, building or structure used in whole or in part for residential purposes.

(c) **MANUFACTURER REQUIREMENTS – GAS EQUIPMENT VENTING SYSTEM PROVIDED.** When the manufacturer of Product Approved side wall horizontally vented gas equipment provides a venting system design or venting system components with the equipment, the instructions provided by the manufacturer for installation of the equipment and the venting system shall include:

1. Detailed instructions for the installation of the venting system design or the venting system components; and
2. A complete parts list for the venting system design or venting system.

(d) **MANUFACTURER REQUIREMENTS – GAS EQUIPMENT VENTING SYSTEM NOT PROVIDED.** When the manufacturer of a Product Approved side wall horizontally vented gas fueled equipment does not provide the parts for venting the flue gases, but identifies “special venting systems”, the following requirements shall be satisfied by the manufacturer:

1. The referenced “special venting system” instructions shall be included with the appliance or equipment installation instructions; and
2. The “special venting systems” shall be Product Approved by the Board, and the instructions for that system shall include a parts list and detailed installation instructions.

(e) A copy of all installation instructions for all Product Approved side wall horizontally vented gas fueled equipment, all venting instructions, all parts lists for venting instructions, and/or all venting design instructions shall remain with the appliance or equipment at the completion of the installation.

# LOCATION REQUIREMENTS

## GENERAL INFORMATION

### **⚠ WARNING**

**WHEN THIS FURNACE IS INSTALLED IN A RESIDENTIAL GARAGE, IT MUST BE INSTALLED SO THE BURNERS AND IGNITION SOURCE ARE LOCATED NO LESS THAN 18 INCHES [450MM] ABOVE THE FLOOR. THIS IS TO PREVENT THE RISK OF IGNITING FLAMMABLE VAPORS WHICH MAY BE PRESENT IN A GARAGE. ALSO, THE FURNACE MUST BE LOCATED OR PROTECTED TO AVOID PHYSICAL DAMAGE BY VEHICLES. FAILURE TO FOLLOW THESE WARNINGS CAN CAUSE A FIRE OR EXPLOSION, RESULTING IN PROPERTY DAMAGE, PERSONAL INJURY OR DEATH.**

1. **IMPORTANT:** If installing the unit over a finished ceiling or living area, be certain to install an auxiliary condensate drain pan under the entire unit. This auxiliary drain pan should extend under any evaporator coil installed with the furnace and the open portion of the condensate drain assembly. See “Condensate Drain/Neutralizer” section for more details.
2. **IMPORTANT:** If using a cooling evaporator coil with this furnace, be sure the air passes over the heat exchanger before passing over the cooling coil. The cooled air passing over the warm ambient air inside the heat exchanger tubes can cause condensation inside the tubes resulting in corrosion and eventual failure.

If these are manual dampers, they must be equipped to prevent heating or cooling operation unless the damper is in the full heat or cool position.

3. **IMPORTANT:** Furnace must be installed level from front-to-back or with a slight tilt such that the back of the furnace is up to 1/2" higher than the front of the furnace as shown in Figure 3.

**NOTE:** These furnaces are approved for installation in attics, as well as alcoves, utility rooms, closets and crawlspaces. Provisions must be made to prevent freezing of condensate.

### FREEZE PROTECTION

For installations where the furnace may reach temperatures below 32°F (0°C) (such as an alcove or attic installation), the installer must take precautions to ensure that the drain trap and connected drain pipe do not freeze. Local codes and practices should be followed in order to prevent freezing.

If the drain trap is installed within the furnace cabinet, no freeze protection is required. When the trap is mounted outside or partially outside the cabinet, it must be pro-

tected from freezing. Regardless of the location of the drain trap, any exposed drain piping must be protected from freezing as required by local practices or codes. A UL or CSA listed heat tape or UL or CSA approved heating cable with a rating of 3-6 watts per foot is acceptable protection when installed and maintained in accordance with the manufacturer’s instructions. Good installation practices necessitate that the installer verify heat tape operation in accordance with the manufacturer’s instructions at the time of installation.

**IMPORTANT:** Support this unit when installed. Since this furnace is suitable for attic or crawl space installation, it may be installed on combustible wood flooring or by using support brackets.

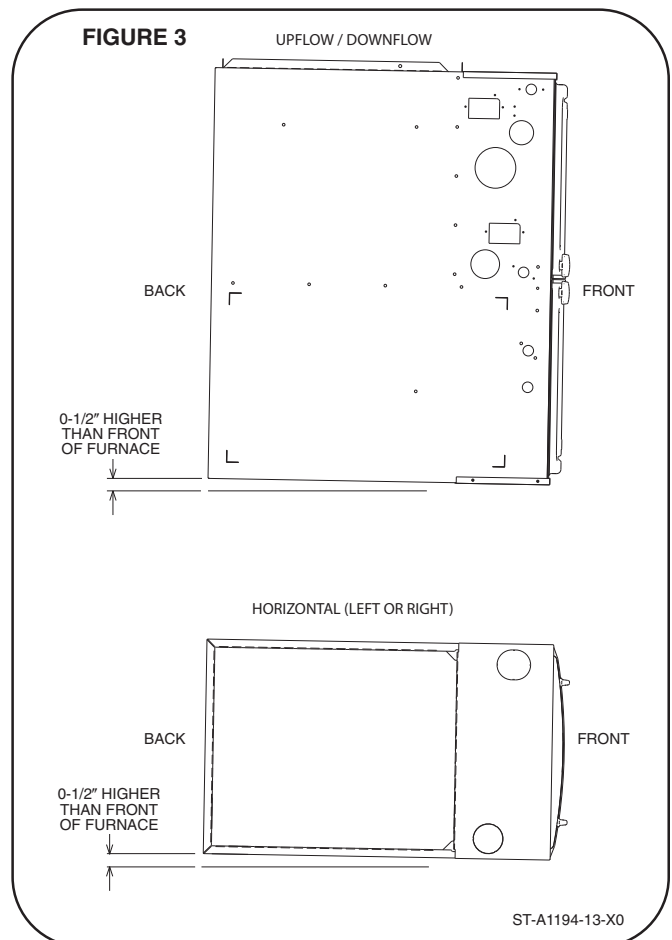

# LOCATION REQUIREMENTS

## GENERAL INFORMATION (cont.)

### **⚠ WARNING**

THIS FURNACE IS NOT APPROVED OR RECOMMENDED FOR INSTALLATION ON ITS BACK, WITH ACCESS DOORS FACING UPWARDS.

### SITE SELECTION

1. Select a site in the building near the center of the proposed, or existing, duct system.
2. Give consideration to the vent system piping when selecting the furnace location. Be sure the venting system can get from the furnace to the termination with minimal length and elbows.
3. Locate the furnace near the existing gas piping. Or, if running a new gas line, locate the furnace to minimize the length and elbows in the gas piping. See Figure 5.
4. Locate the furnace to maintain proper clearance to combustibles as shown in following Figure 6.

### **⚠ WARNING**

DO NOT LIFT THE UNIT BY THE HEAT EXCHANGER TUBES. DOING SO CAN DAMAGE THE HEAT EXCHANGER ASSEMBLY.

### CLEARANCE – ACCESSIBILITY

The design of forced air furnaces with input ratings as listed in the tables under Figure 6 are certified by CSA-International for the clearances to combustibles shown in inches.

See name/rating plate and clearance label for specific model number and clearance information.

Service clearance of at least 24 inches (30 cm) is recommended in front of all furnaces.

**NOTE:** Use recommended 24" (30 cm) clearance if accessibility clearances are greater than fire protection clearances.

For downflow non-zero clearance furnace installations, the minimum clearance required on the right side of the furnace is shown in Figure 4. If this clearance cannot be maintained, a downflow zero-clearance kit; [RXGY-ZK](#) will need to be installed.

### **⚠ WARNING**

UPFLOW FURNACES ARE DESIGN- CERTIFIED FOR INSTALLATION ON COMBUSTIBLE FLOORS. NOTE, HOWEVER, THAT FURNACES MUST NOT BE INSTALLED DIRECTLY ON CARPETING, TILE OR OTHER COMBUSTIBLE MATERIAL OTHER THAN WOOD FLOORING. INSTALLATION ON A COMBUSTIBLE MATERIAL CAN RESULT IN FIRE, CAUSING PROPERTY DAMAGE, PERSONAL INJURY OR DEATH.

### **⚠ WARNING**

COMBUSTIBLE MATERIAL MUST NOT BE PLACED ON OR AGAINST THE FURNACE JACKET. THE AREA AROUND THE FURNACE MUST BE KEPT CLEAR AND FREE OF ALL COMBUSTIBLE MATERIALS INCLUDING GASOLINE AND OTHER FLAMMABLE VAPORS AND LIQUIDS. PLACEMENT OF COMBUSTIBLE MATERIALS ON, AGAINST OR AROUND THE FURNACE JACKET CAN CAUSE AN EXPLOSION OR FIRE RESULTING IN PROPERTY DAMAGE, PERSONAL INJURY OR DEATH. THE HOMEOWNER SHOULD BE CAUTIONED THAT THE FURNACE AREA MUST NOT BE USED AS A BROOM CLOSET OR FOR ANY OTHER STORAGE PURPOSES.

**FIGURE 4** CLEARANCE FLUE VENT TO WALL

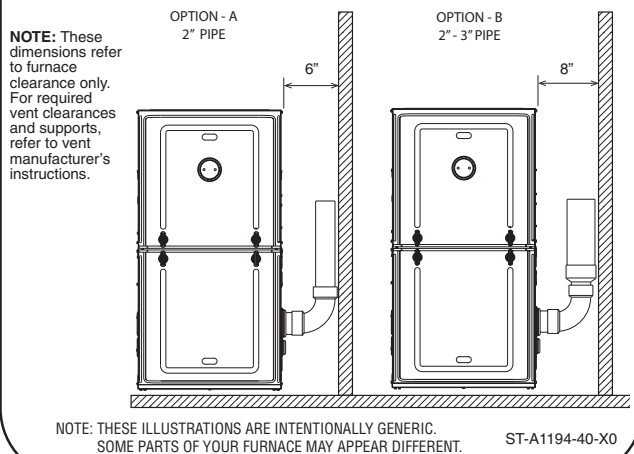

**FIGURE 5**

**NOTE:** HORIZONTAL LEFT ORIENTATION DEPICTED IN ILLUSTRATION. HORIZONTAL RIGHT ORIENTATION IS SIMILAR IN INSTALLATION.

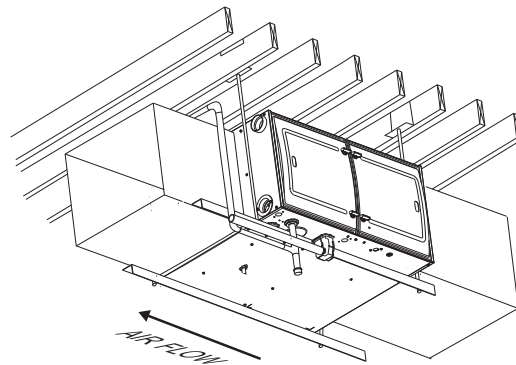

ST-A1194-05-X0

**FIGURE 6**  
UNIT DIMENSIONS (CLEARANCE TO COMBUSTIBLES)

**UNIT DIMENSIONS  
(CLEARANCE TO COMBUSTIBLES)**

MODEL	MINIMUM CLEARANCE (IN.)				SHIPPING WEIGHTS	
	LEFT SIDE	RIGHT	BACK	TOP		
(-)96VA060 & (-)96MDV060	0	0	0	1	2	0
(-)96VA070 & (-)96MDV070	0	0	0	1	2	0
(-)96VA085 & (-)96MDV085	0	0	0	1	2	0
(-)96VA100 & (-)96MDV100	0	0	0	1	2	0

\*A SERVICE CLEARANCE OF AT LEAST 24" IS RECOMMENDED IN FRONT OF ALL FURNACES

FLANGE DIMENSIONS		
A	B	C
17 1/2	16 13/64	16 13/64
21	19 49/64	19 49/64
24 1/2	23 17/64	23 13/64

SUPPLY AND RETURN DEPICTED AS UPFLOW CONFIGURATION.  
FLANGE CONFIGURATION WILL VARY DEPENDING ON INSTALLATION ORIENTATION.

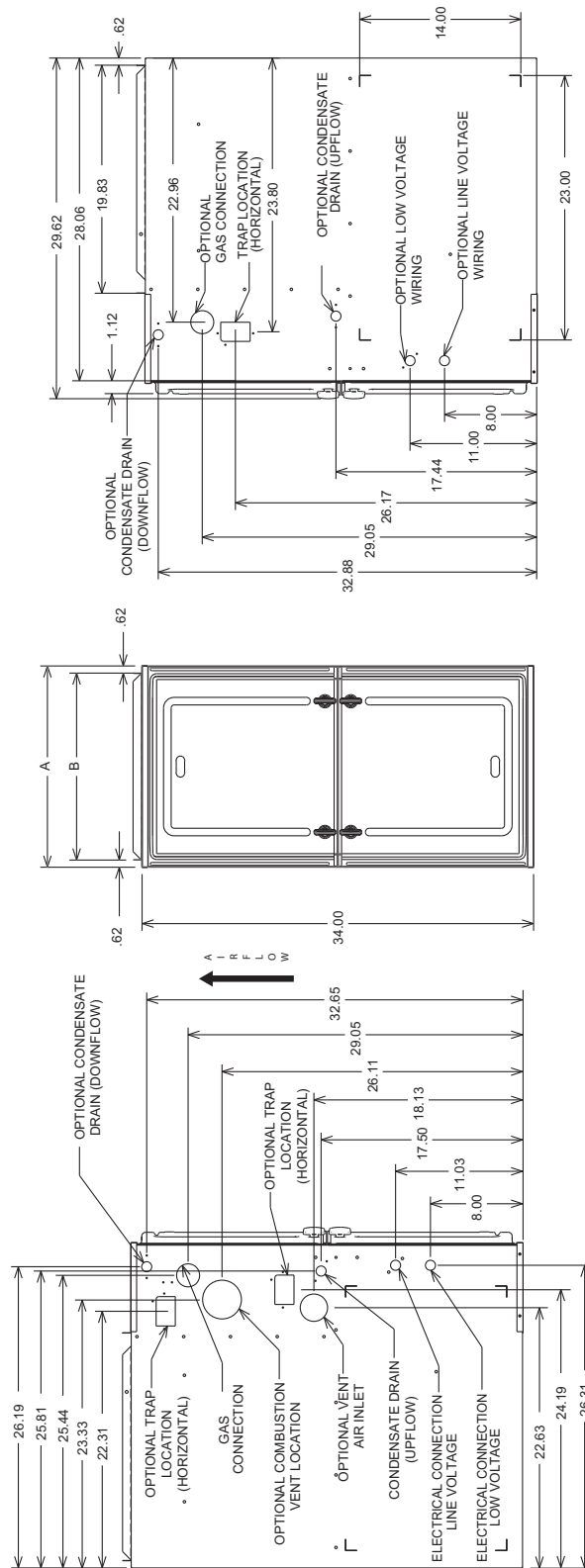
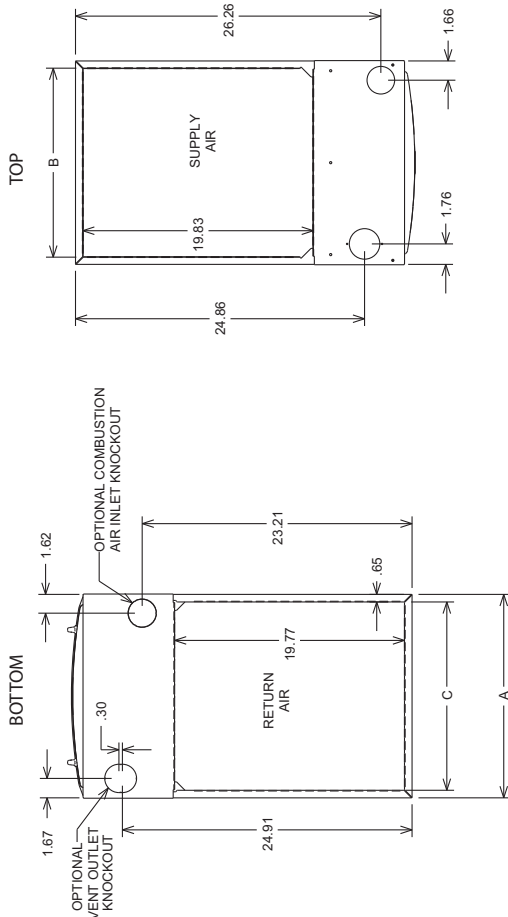

ST-A194-01-X0

RIGHT SIDE

FRONT

LEFT SIDE

# FIELD CONVERSIONS

## GENERAL CONVERSION INSTRUCTIONS

### CONDENSATE PVC/HOSE OPTIONS

#### CONDENSATE DRAIN COUPLING

CONDENSATE DRAINAGE HAS OPTIONS FOR 3/4" OR 1/2" PVC CONNECTIONS. THE CONDENSATE DRAIN COUPLING CONNECTS THE RUBBER HOSES FROM INSIDE THE UNIT TO THE PVC PIPE EXTERIOR OF THE UNIT. PVC PIPE CAN BE CEMENTED DIRECTLY TO THE COUPLING AND THE TRAP WITH PROPER PVC CEMENT AND PRIMER.

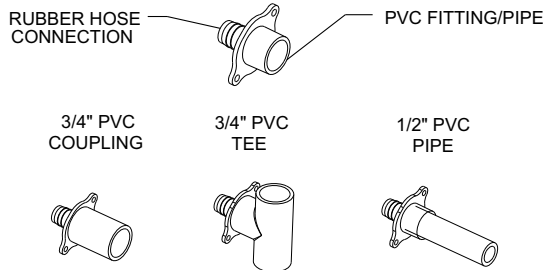

#### CONDENSATE TRAP

IN ADDITION TO PVC CONNECTIONS, THE CONDENSATE TRAP CAN ACCOMMODATE A 5/8" RUBBER HOSE WITH A HOSE CLAMP WHEN LOCATED INSIDE THE UNIT.

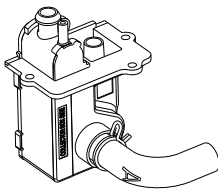

THE CONDENSATE TRAP HAS 2 SIDES PLEASE NOTE THEIR LOCATIONS FOR DRAIN CONNECTIONS DURING CONVERSION.

**NOTE: IMPROPER HOSE CONNECTIONS WILL PREVENT CONDENSATE FROM DRAINING AND MAY DAMAGE FURNACE.**

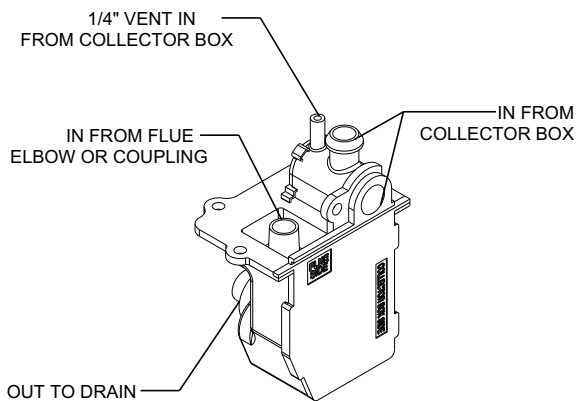

### CONVERSION AND INSTALLATION CONSIDERATIONS

**ALL CONVERSIONS REQUIRE THE CONDENSATE PLUMBING TO HAVE DECLINE IN THE DIRECTION OF THE WATER FLOW.**

WHEN INSTALLING AND MOVING CONDENSATE PLUMBING THE HOSES SHOULD BE FREE OF KINKS FOR PROPER WATER FLOW.

WHEN DRAIN HOSE OR CONDENSATE TRAP HOSE ROUTING CHANGES ARE NECESSARY BE SURE TO PLUG OR CAP ANY UNUSED HOSE TAPS.

THE INDUCER COUPLING COMES FROM THE FACTORY WITH A 10° TILT FOR UP FLOW INSTALLATIONS. WHEN CONVERTED TO DOWN FLOW THE COUPLING REQUIRES A ROTATION A MINIMUM OF 10° FROM HORIZONTAL AS SHOWN.

#### 10-20° TILT ON INDUCER COUPLING

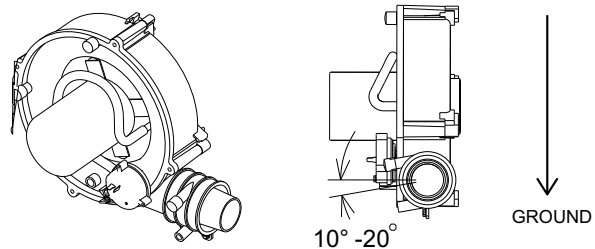

**HORIZONTAL INSTALLATIONS REQUIRE CONDENSATE TRAP TO BE MOUNTED EXTERNALLY BELOW THE UNIT:**

-USE CAUTION: MOUNT THE TRAP AFTER THE UNIT IS AT THE POINT OF INSTALLATION TO PREVENT DAMAGE TO THE TRAP DURING TRANSPORT.

-HAND TIGHTEN SCREWS WHEN MOUNTING THE TRAP OR THE CONDENSATE DRAIN COUPLING TO THE CABINET TO PREVENT DAMAGE TO THE MOUNTING FLANGE.

-USE PROPER FREEZE PROTECTION IF REQUIRED.

-ALLOW MINIMUM OF 6" BELOW THE FURNACE FOR CLEARANCE.

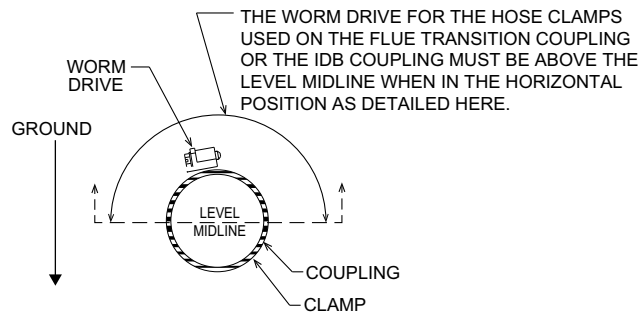

#### NOTE:

IF THE IDB COUPLING IS REMOVED, IT MUST BE REPLACED IN THE PROPER ORIENTATION. AN ARROW IS PRESENT ON THE COUPLING TO INDICATE THE DIRECTION OF EXHAUST FLOW. MAKE SURE THE ARROW POINTS IN THE CORRECT DIRECTION.

# FIELD CONVERSIONS

## GENERAL PARTS REQUIRED FOR CONVERSIONS

SEE PAGE 14 FOR DETAILS ON KIT APPLICATIONS

### PARTS BAG (PROVIDED WITH UNIT)

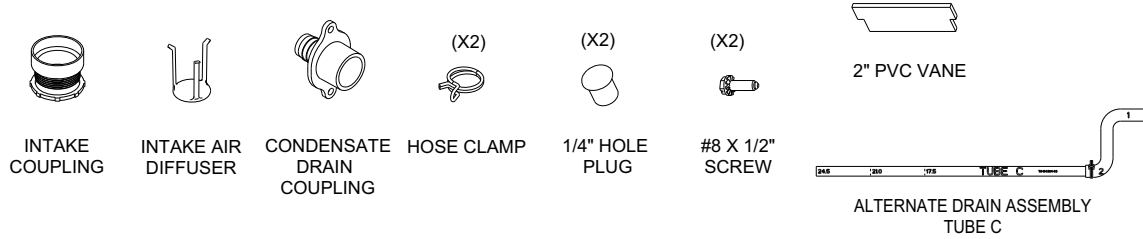

### CONVERSION KIT **RXGY-CK**

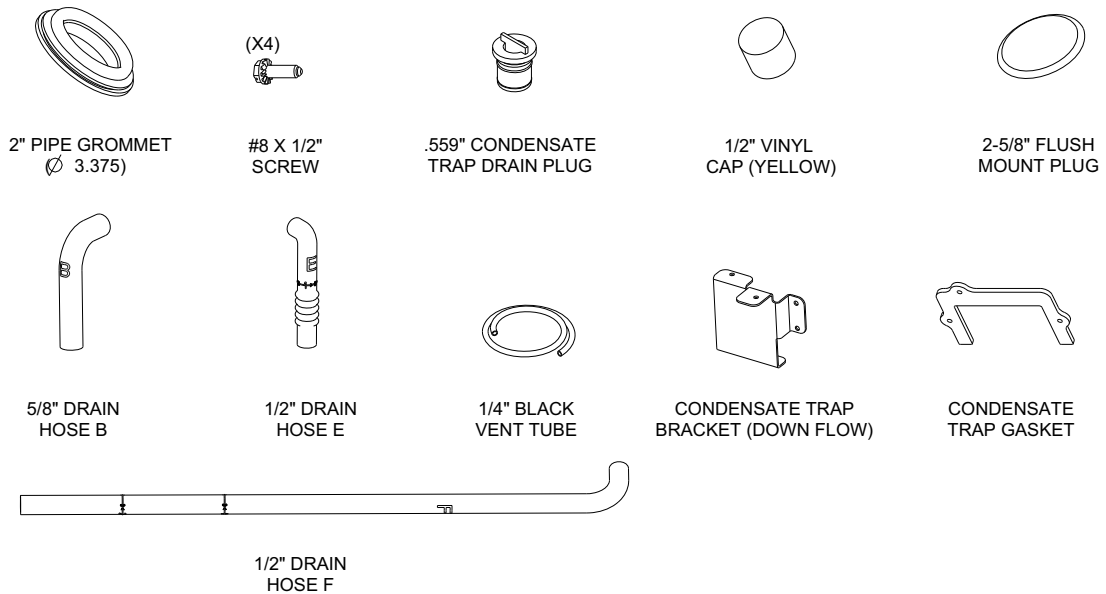

### CONVERSION KIT **RXGY-ZK**

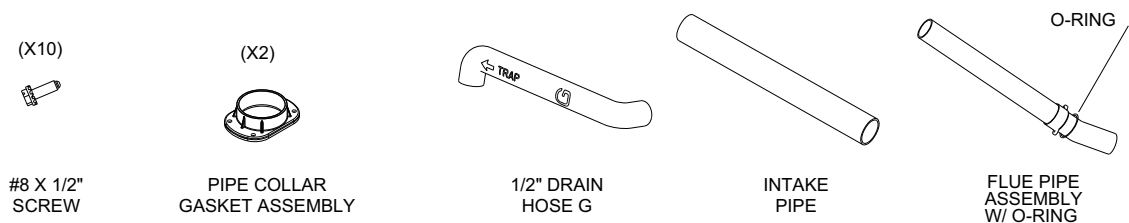

SEE NEXT PAGE FOR APPLICABLE CONFIGURATIONS

# FIELD CONVERSIONS

## FIELD CONVERSION TO VARIOUS CONFIGURATIONS

Furnaces can be converted in the field from upflow (as-shipped) to downflow, horizontal left or horizontal right as necessary. In addition, there are different venting options, including a zero-clearance option, to give the installer flexibility in locating the venting for this furnace.

LISTS OF MATERIALS FOR PARTS BAGS AND CONVERSION KITS. . . . . Pg 12

GENERAL CONVERSION INSTRUCTIONS AND TIPS . . . . . Pg 13

UPFLOW WITH VERTICAL VENT. . . . . Pg 15-16

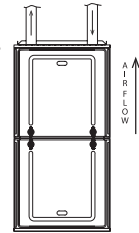

UPFLOW WITH LEFT SIDE VENT.  
(REQUIRES CONVERSION KIT RXGY-CK) . . . . . Pg 17-18

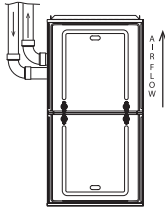

DOWNFLOW WITH RIGHT VENT (NON-ZERO CLEARANCE).  
(REQUIRES CONVERSION KIT RXGY-CK) . . . . . Pg 19-22

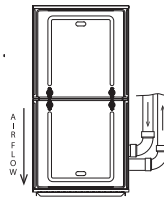

DOWNFLOW ZERO-CLEARANCE  
(REQUIRES CONVERSION KIT RXGY-CK AND ZERO-CLEARANCE KIT RXGY-ZK) . . . . . Pg 23-27

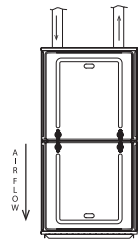

HORIZONTAL RIGHT WITH RIGHT VENT  
(REQUIRES CONVERSION KIT RXGY-CK) . . . . . Pg 28-30

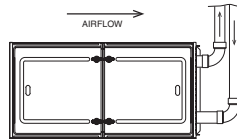

HORIZONTAL RIGHT WITH VERTICAL VENT  
(REQUIRES CONVERSION KIT RXGY-CK) . . . . . Pg 31-33

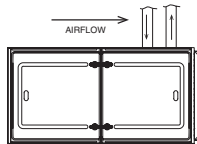

HORIZONTAL LEFT WITH RIGHT VENT.  
(REQUIRES CONVERSION KIT RXGY-CK AND ZERO-CLEARANCE KIT RXGY-ZK) . . . . . Pg 34-38

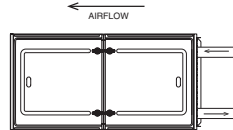

HORIZONTAL LEFT WITH LEFT VENT  
(REQUIRES CONVERSION KIT RXGY-CK) . . . . . Pg 39-41

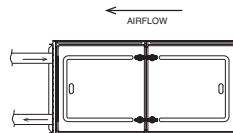

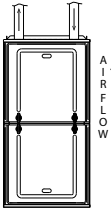

# UPFLOW VERTICAL VENT

## PARTS NEEDED:

**⚠** PARTS NEEDED FOR THIS CONVERSION REQUIRE ITEMS FROM THE **PARTS BAG ONLY**. NO OTHER CONVERSION KITS ARE NEEDED.

FROM PARTS BAG (PROVIDED WITH UNIT)  
TUBE C

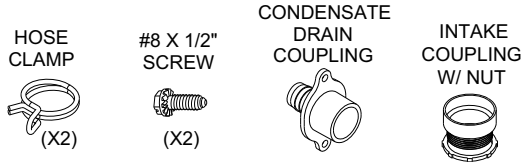

## TOOLS/MATERIALS NEEDED:

ELECTRIC DRILL    1/8" DRILL BIT    PLIERS  
1/4" HEX HEAD DRIVER    TUBE CUTTER

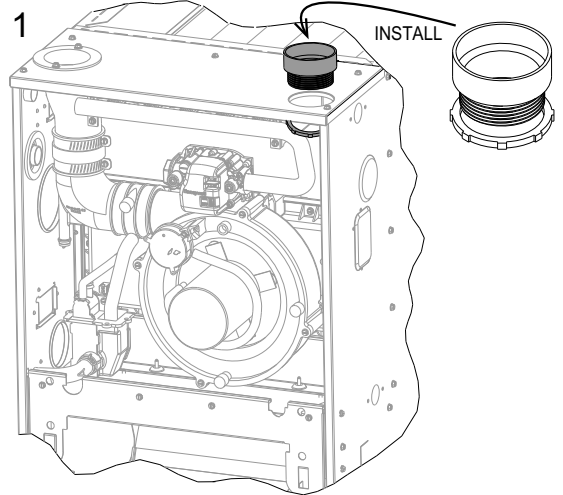

INSTALL INTAKE COUPLING IN TOP PLATE.

NOTE: THESE CONVERSION INSTRUCTIONS ARE INTENTIONALLY GENERIC, SOME PARTS MAY BE DIFFERENT IN YOUR FURNACE

## 2 OPTION DRAIN LEFT

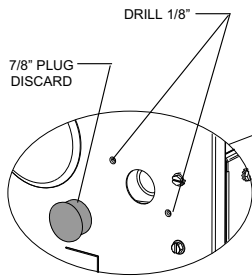

DETERMINE RIGHT OR LEFT DRAIN OPTION.  
LOCATE 7/8" HOLE IN JACKET SIDE.  
REMOVE PLUG - DISCARD.  
DRILL (2)  $\varnothing$  1/8" HOLES FOR THE CONDENSATE DRAIN COUPLING.

## OPTION DRAIN RIGHT

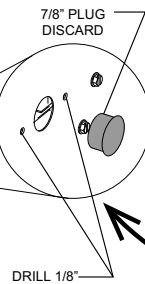

## 3

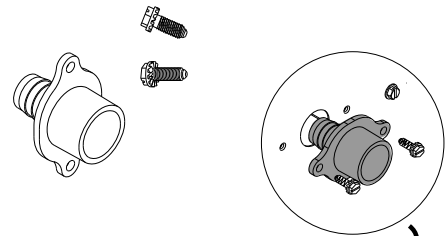

INSTALL

INSTALL CONDENSATE DRAIN COUPLING USING (2) SCREWS. INSTALL IN JACKET WITH THE BARBED FITTING POINTED INTO THE VESTIBULE.

## 4A

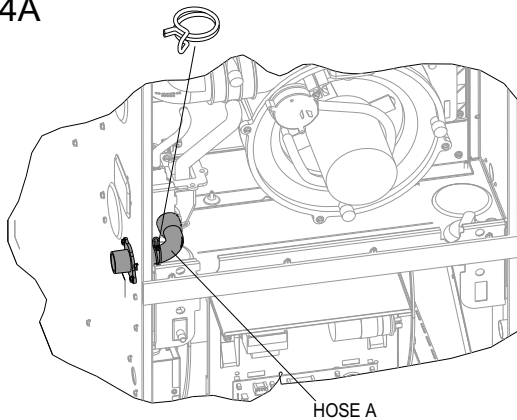

### 4a - LEFT SIDE DRAIN OPTION

ATTACH HOSE A (PRE-INSTALLED) TO CONDENSATE DRAIN COUPLING. INSTALL HOSE CLAMP ON HOSE OVER CONDENSATE DRAIN COUPLING.

**NOTE:**  
USE SOAPY WATER TO FACILITATE EASY HOSE AND TUBE ASSEMBLY

## 4B

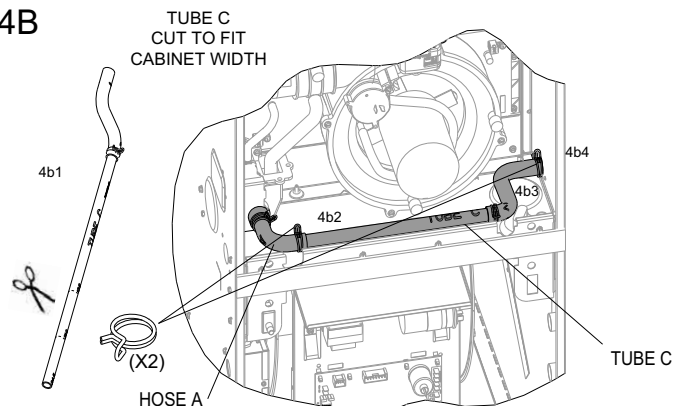

### 4b - RIGHT SIDE DRAIN OPTION

4b1 - CUT TUBE C TO FIT CORRESPONDING CABINET WIDTH.  
4b2 - INSTALL TUBE C WITH HOSE CLAMP AS SHOWN TO HOSE A (PRE-INSTALLED).  
4b3 - ATTACH TUBE C ASSEMBLY TO CONDENSATE DRAIN COUPLING AS SHOWN.  
4b4 - INSTALL HOSE CLAMP OVER HOSE ON CONDENSATE DRAIN COUPLING.

**NOTE:**  
USE SOAPY WATER TO FACILITATE EASY HOSE AND TUBE ASSEMBLY

ST-A1194-28-X0



## Checklist:

- \_\_\_\_\_ VERIFY ALL HOSES ARE SECURE AND FULLY SEATED.
- \_\_\_\_\_ CONFIRM THAT ALL HOSES ARE FREE OF KINKS
- \_\_\_\_\_ CONFIRM ALL HOSES AND OTHER DRAIN PARTS HAVE A SLOPE IN DIRECTION OF WATER FLOW
- \_\_\_\_\_ ALL CLAMPS AND COUPLINGS ARE TIGHTENED
- \_\_\_\_\_ ALL DRAIN PORTS ARE PLUGGED
- \_\_\_\_\_ UNIT HAS FORWARD PITCH
- \_\_\_\_\_ HEAT TAPE INSTALLED(IF REQUIRED)

---

## Notes:

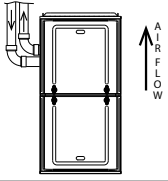

# UPFLOW LEFT VENT

## PARTS NEEDED:

FROM PARTS BAG (PROVIDED W/UNIT)

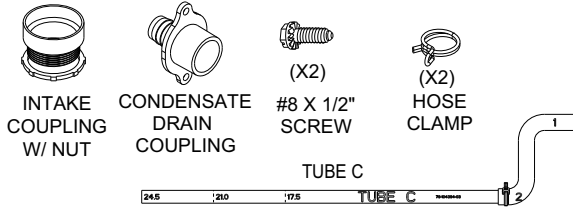

FROM CONVERSION KIT **RXGY-CK**

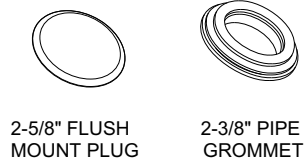

**!** PARTS NEEDED FOR THIS CONVERSION REQUIRE THE OUTLINED ITEMS FROM THE PARTS BAG AND CONVERSION KIT **RXGY-CK**. YOU MUST HAVE THESE PARTS BEFORE PROCEEDING.

## TOOLS/MATERIALS NEEDED:

- ELECTRIC DRILL
- PLIERS
- 5/16 HEX HEAD DRIVER
- TUBING CUTTER
- 1/8" DRILL BIT
- FLAT HEAD SCREWDRIVER
- 1/4" HEX HEAD DRIVER

NOTE: THESE CONVERSION INSTRUCTIONS ARE INTENTIONALLY GENERIC, SOME PARTS MAY BE DIFFERENT IN YOUR FURNACE

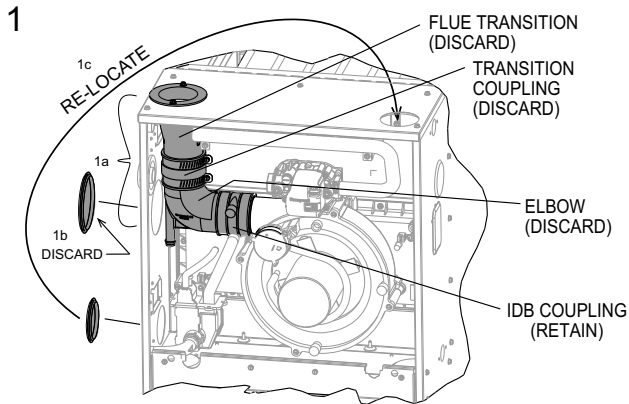

- 1a - REMOVE FLUE TRANSITION, TRANSITION COUPLING, AND ELBOW. (NOTE: REMOVE INDUCER COUPLING W/ELBOW FOR EASIER REMOVAL).
- 1b - REMOVE 2-3/8" FLUSH MOUNT PLUG FROM JACKET - DISCARD.
- 1c - RELOCATE 2-3/8" FLUSH MOUNT PLUG FROM JACKET TO TOP PLATE.

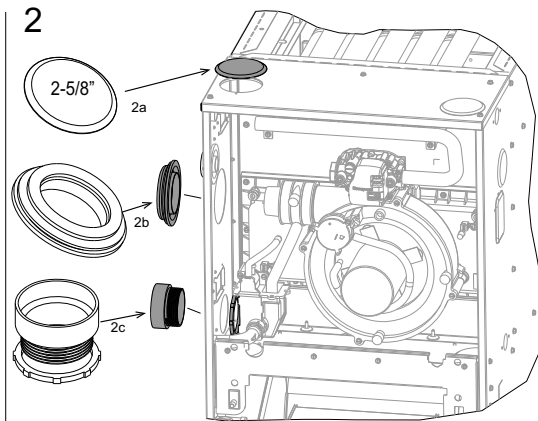

NOTE: IF THE IDB COUPLING IS REMOVED, IT MUST BE REPLACED IN THE PROPER ORIENTATION. AN ARROW IS PRESENT ON THE COUPLING TO INDICATE THE DIRECTION OF EXHAUST FLOW. MAKE SURE THE ARROW POINTS IN THE CORRECT DIRECTION.

- 2a - INSTALL 2-5/8" FLUSH MOUNT PLUG IN TOP PLATE.
- 2b - INSTALL 2" PIPE GROMMET AS SHOWN.
- 2c - INSTALL INTAKE COUPLING AS SHOWN.

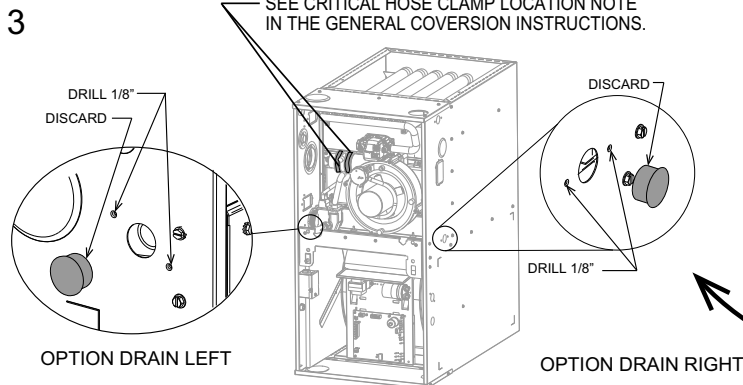

DETERMINE RIGHT OR LEFT DRAIN OPTION. LOCATE 7/8" HOLE IN JACKET SIDE. REMOVE PLUG - DISCARD. DRILL (2)  $\phi$ 1/8" HOLES FOR THE CONDENSATE DRAIN COUPLING.

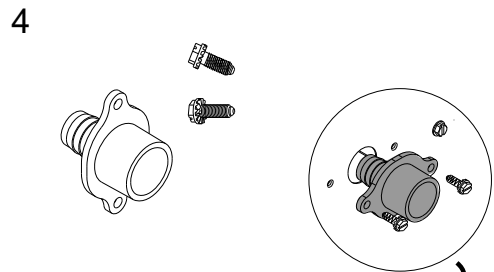

INSTALL CONDENSATE DRAIN COUPLING USING (2) SCREWS. INSTALL IN JACKET WITH THE BARBED FITTING POINTED INTO THE VESTIBULE.

Field Conversions

5A

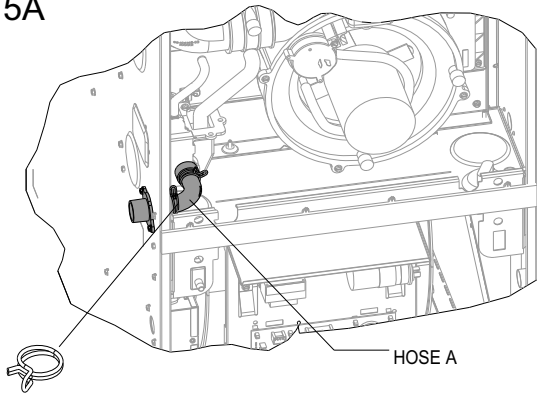

**NOTE:**  
USE SOAPY WATER TO FACILITATE EASY  
HOSE AND TUBE ASSEMBLY

5a - LEFT SIDE DRAIN OPTION

ATTACH HOSE A (PRE-INSTALLED) TO CONDENSATE DRAIN  
COUPLING. PLACE CLAMP OVER HOSE ON CONDENSATE  
DRAIN COUPLING.

5B

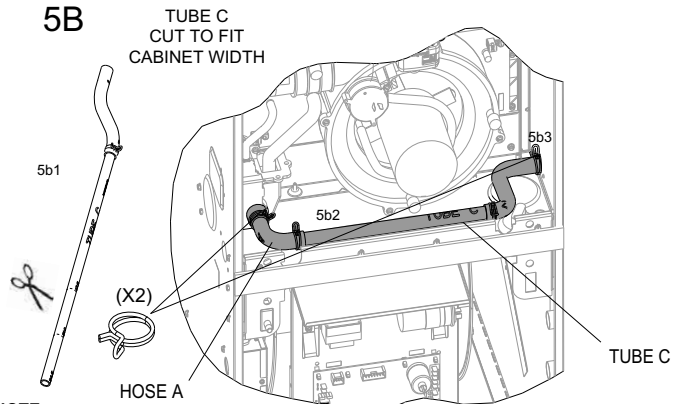

**NOTE:**  
USE SOAPY WATER TO FACILITATE EASY  
HOSE AND TUBE ASSEMBLY

5b - RIGHT SIDE DRAIN OPTION

5b1 - CUT TUBE C TO FIT CORRESPONDING CABINET WIDTH.  
5b2 - INSTALL TUBE C WITH HOSE CLAMP AS SHOWN TO HOSE A (PRE-INSTALLED).  
5b3 - ATTACH TUBE C ASSEMBLY TO CONDENSATE DRAIN COUPLING AS SHOWN.  
5b4 - INSTALL HOSE CLAMP OVER HOSE ON CONDENSATE DRAIN COUPLING.

## Checklist:

- \_\_\_ VERIFY ALL HOSES ARE SECURE AND FULLY SEATED.
- \_\_\_ CONFIRM THAT ALL HOSES ARE FREE OF KINKS.
- \_\_\_ CONFIRM ALL HOSES AND OTHER DRAIN PARTS HAVE A SLOPE IN DIRECTION OF WATER FLOW
- \_\_\_ BOTH WORM DRIVES ON THE HOSE CLAMPS OF THE IDB COUPLING MUST BE LOCATED ON THE TOP OF THE COUPLING. SEE LOCATION DETAIL IN THE GENERAL CONVERSION INSTRUCTIONS AT THE BEGINNING OF THIS SECTION.
- \_\_\_ ALL CLAMPS AND COUPLINGS ARE TIGHTENED
- \_\_\_ ALL DRAIN PORTS ARE PLUGGED
- \_\_\_ UNIT HAS FORWARD PITCH
- \_\_\_ HEAT TAPE INSTALLED(IF REQUIRED)

## Notes:

# DOWNFLOW W/ RIGHT VENT (NON-ZERO CLEARANCE)

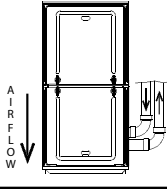

PARTS NEEDED FOR THIS CONVERSION REQUIRE ITEMS FROM THE PARTS BAG AND CONVERSION KIT **RXGY-CK**. YOU MUST HAVE THE PARTS OUTLINED BELOW BEFORE PROCEEDING.

## PARTS NEEDED:

FROM PARTS BAG (PROVIDED WITH UNIT)

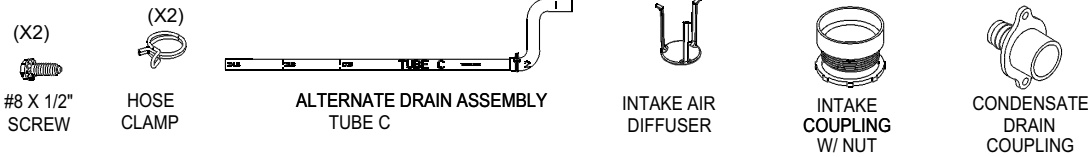

FROM CONVERSION KIT **RXGY-CK**



## TOOLS/MATERIALS NEEDED:

- ELECTRIC DRILL (1) 1/8" DRILL BIT
- (1) 3/16" DRILL BIT
- (1) 1/4" HEX HEAD DRIVER
- (1) 5/16" HEX HEAD DRIVER
- FLAT HEAD SCREWDRIVER
- TUBE CUTTER

NOTE: THESE CONVERSION INSTRUCTIONS ARE INTENTIONALLY GENERIC, SOME PARTS MAY BE DIFFERENT IN YOUR FURNACE  
NOTE: STEPS 1- 5 SHOWN WITH FURNACE IN "AS SHIPPED CONFIGURATION"

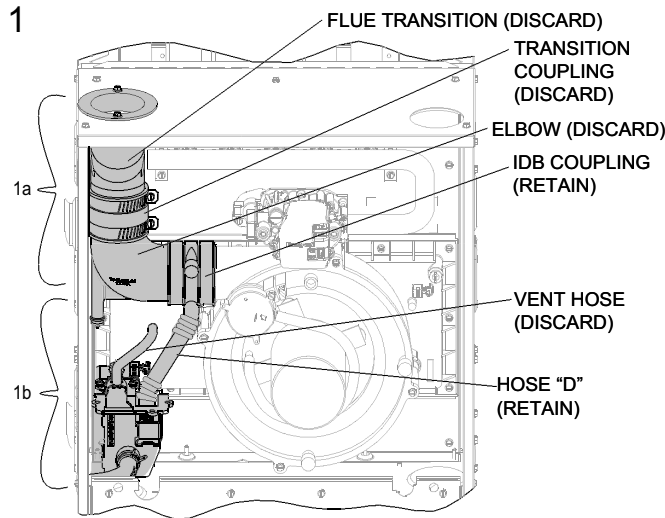

- 1a - REMOVE FLUE TRANSITION, TRANSITION COUPLING, AND ELBOW. (NOTE: REMOVE COUPLING ON INDUCER WITH ELBOW FOR EASIER REMOVAL).
- 1b - REMOVE TRAP AND HOSES. RETAIN HOSE D FOR LATER USE. (NOTE: TO REMOVE TRAP REMOVE (2) SCREWS AND PULL STRAIGHT OUT).

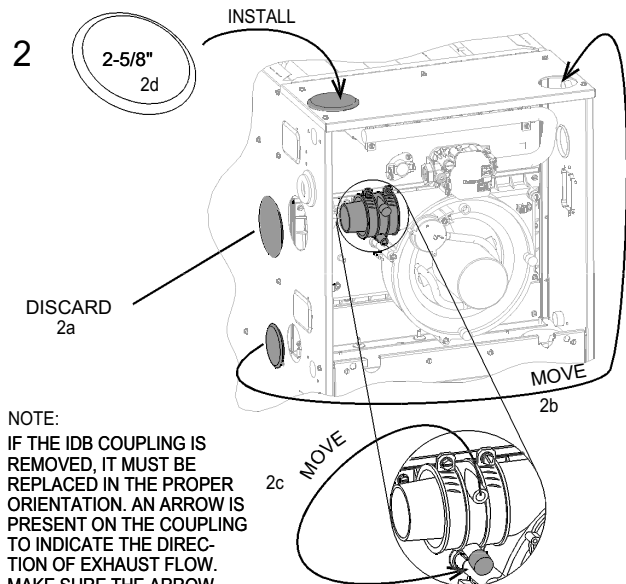

NOTE: IF THE IDB COUPLING IS REMOVED, IT MUST BE REPLACED IN THE PROPER ORIENTATION. AN ARROW IS PRESENT ON THE COUPLING TO INDICATE THE DIRECTION OF EXHAUST FLOW. MAKE SURE THE ARROW POINTS IN THE CORRECT DIRECTION.

- 2a-REMOVE 3-3/8" FLUSH MOUNT PLUG FROM JACKET - DISCARD.
- 2b-RELOCATE 2-3/8" FLUSH MOUNT PLUG FROM JACKET TO TOP PLATE.
- 2c-RELOCATE 1/2" VINYL CAP (YELLOW) IN INDUCER COUPLING.
- 2d-INSTALL 2-5/8" FLUSH PLUG IN TOP PLATE.

Field Conversions

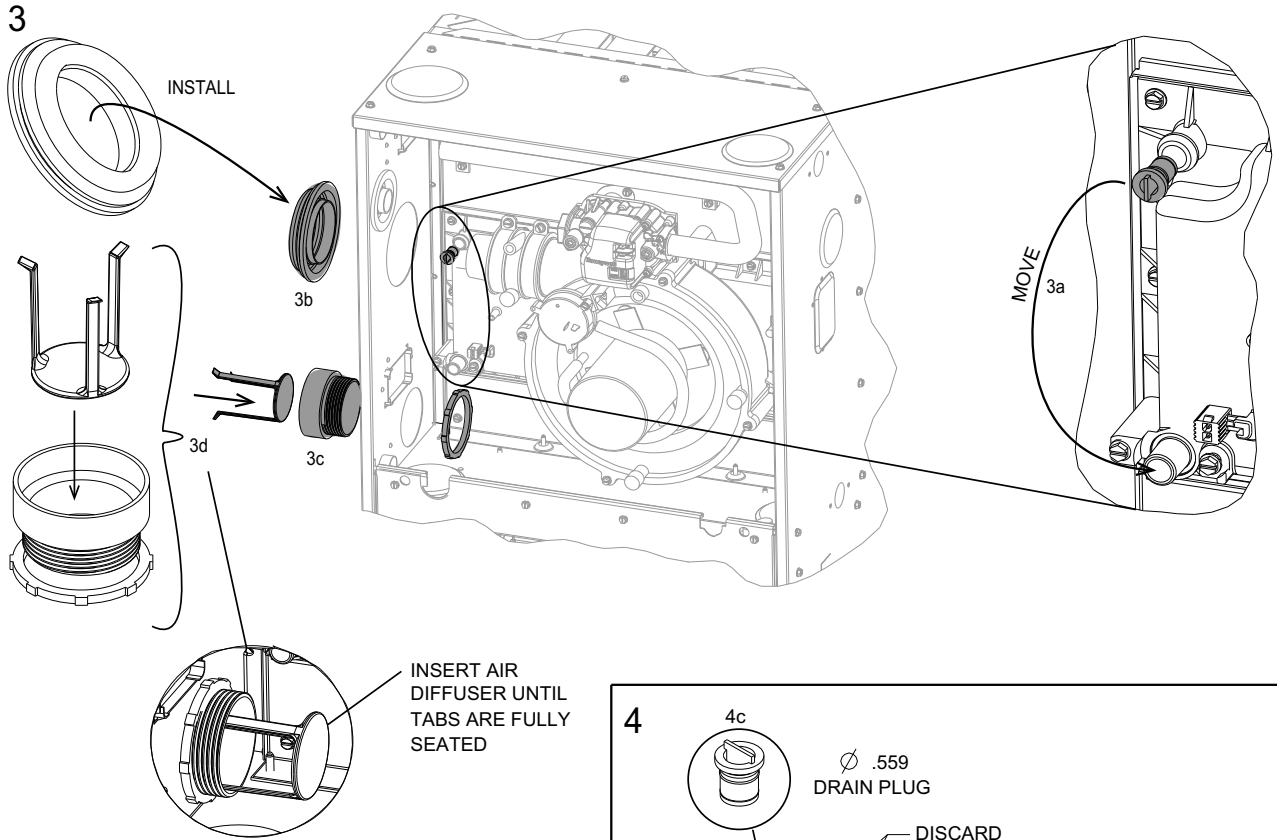

**NOTE:**  
DIFFUSER MAY HAVE A TENDENCY TO FALL OUT OF THE COUPLING AT THIS STEP. THE INSTALLER MAY ELECT TO INSTALL THE DIFFUSER AFTER ROTATING THE FURNACE TO THE HORIZONTAL POSITION.

- 3a - RELOCATE .403" DRAIN PLUG IN THE COLLECTOR BOX.
- 3b - INSTALL 2" PIPE GROMMET
- 3c - INTAKE COUPLING IN JACKET AS SHOWN.
- 3d - INSERT AIR DIFFUSER INTO COUPLING UNTIL TABS ARE SEATED.

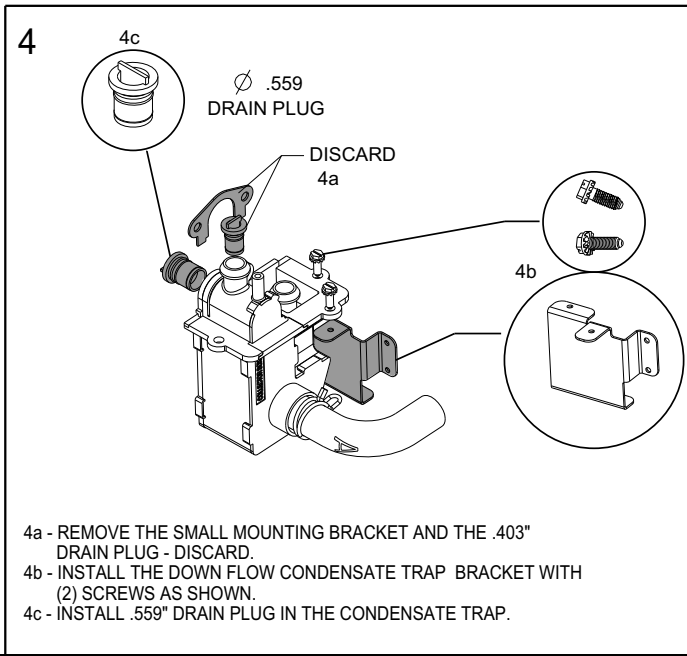

- 4a - REMOVE THE SMALL MOUNTING BRACKET AND THE .403" DRAIN PLUG - DISCARD.
- 4b - INSTALL THE DOWN FLOW CONDENSATE TRAP BRACKET WITH (2) SCREWS AS SHOWN.
- 4c - INSTALL .559" DRAIN PLUG IN THE CONDENSATE TRAP.

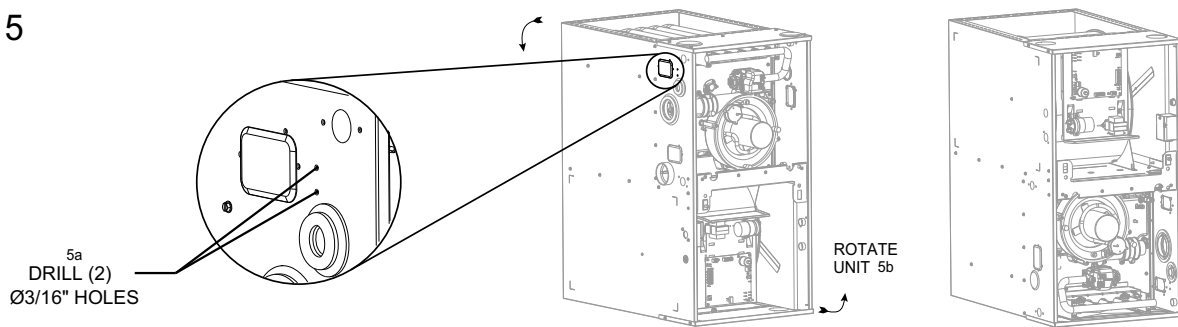

- 5a - PRE-DRILL (2) Ø 3/16" HOLES IN JACKET AS SHOWN FOR CONDENSATE TRAP BRACKET.
- 5b - ROTATE UNIT 180°

**NOTE: REMAINING STEPS SHOWN WITH FURNACE IN DOWN FLOW ORIENTATION**

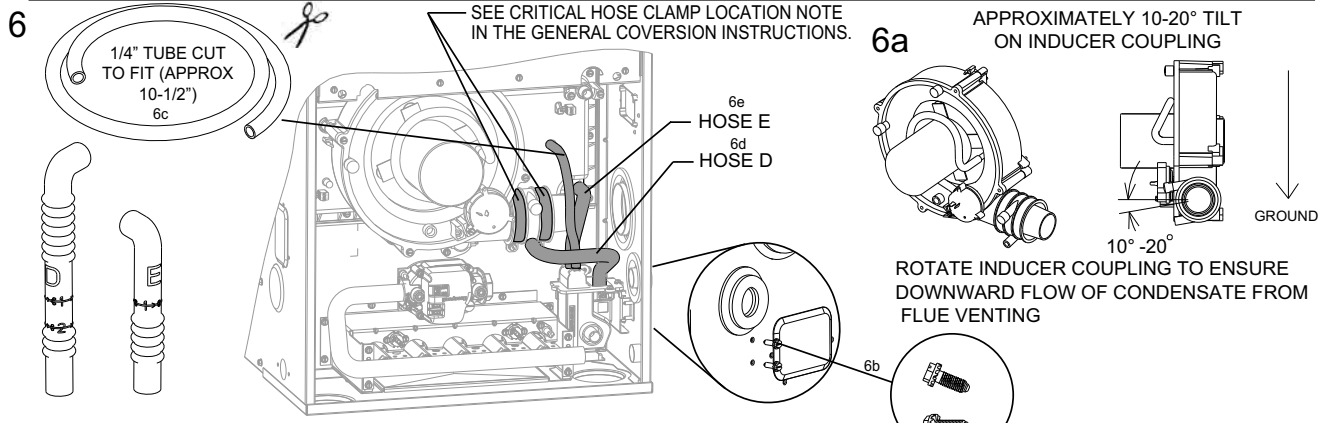

- 6b - INSTALL CONDENSATE TRAP BY MOUNTING BRACKET TO JACKET USING (2) SCREWS
- 6c - CUT 1/4" VENT TUBE TO FIT (APPROX. 10-1/2"). INSTALL AS SHOWN.
- 6d - INSTALL HOSE D (REMOVED IN STEP 1) FROM INDUCER COUPLING TO THE FLUE TAP IN THE CONDENSATE TRAP.
- 6e - INSTALL HOSE E FROM COLLECTOR BOX TO TOP OF CONDENSATE TRAP.

**NOTE:**  
USE SOAPY WATER TO FACILITATE EASY HOSE AND TUBE ASSEMBLY

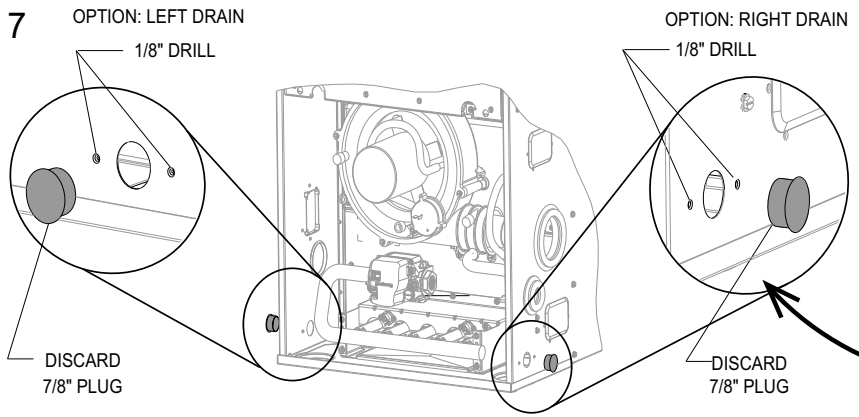

DETERMINE RIGHT OR LEFT DRAIN OPTION.  
LOCATE 7/8" HOLE IN JACKET SIDE AND REMOVE PLUG - DISCARD.  
DRILL (2) Ø 1/8" HOLES FOR CONDENSATE DRAIN COUPLING.

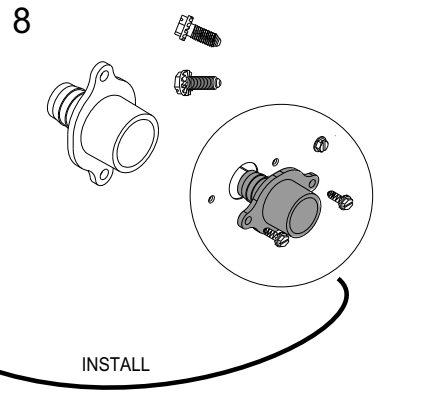

INSTALL CONDENSATE DRAIN COUPLING USING (2) SCREWS. INSTALL IN JACKET WITH THE BARBED FITTING POINTED INTO THE VESTIBULE.

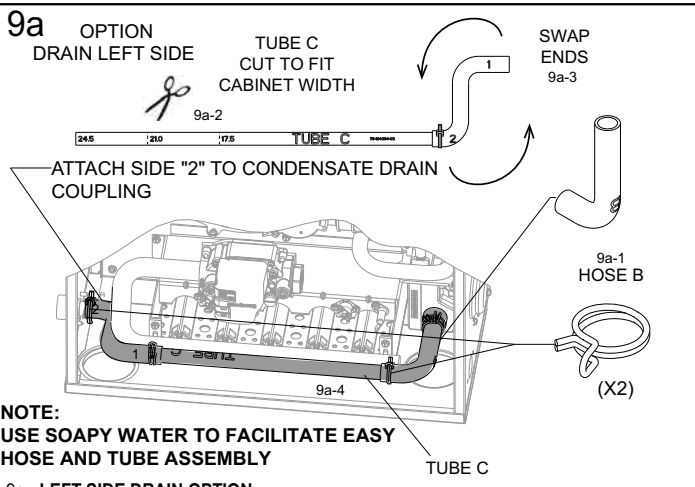

**NOTE:**  
USE SOAPY WATER TO FACILITATE EASY HOSE AND TUBE ASSEMBLY

- 9a - LEFT SIDE DRAIN OPTION
- 9a-1- REMOVE HOSE A (FACTORY INSTALLED ON CONDENSATE TRAP) & REPLACE WITH HOSE B REUSING SUPPLIED CLAMP.
- 9a-2- CUT TUBE C ON MARKED LINES CORRESPONDING TO CABINET WIDTH.
- 9a-3- ROTATE RUBBER HOSE ON TUBE C SO THAT SIDE "1" CONNECTS TO PVC & SIDE "2" TO CONDENSATE DRAIN COUPLING. INSTALL CLAMP OVER HOSE ON CONDENSATE DRAIN COUPLING.
- 9a-4- INSTALL TUBE C USING HOSE CLAMP.

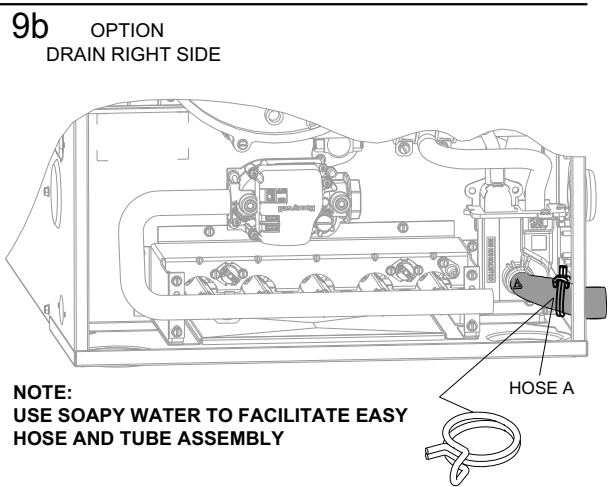

**NOTE:**  
USE SOAPY WATER TO FACILITATE EASY HOSE AND TUBE ASSEMBLY

- 9b - RIGHT SIDE DRAIN OPTION
- ATTACH HOSE A (FACTORY INSTALLED) TO CONDENSATE DRAIN COUPLING. INSTALL CLAMP OVER HOSE ON CONDENSATE DRAIN COUPLING.

ST-A1194-30-X0

Field Conversions

## Checklist:

- \_\_\_\_\_ VERIFY ALL HOSES ARE SECURE AND FULLY SEATED.
  - \_\_\_\_\_ ALL DRAIN PORTS ARE PLUGGED
  - \_\_\_\_\_ UNIT HAS FORWARD PITCH
  - \_\_\_\_\_ HEAT TAPE INSTALLED(IF REQUIRED)
  - \_\_\_\_\_ CONFIRM THAT ALL HOSES ARE FREE OF KINKS
  - \_\_\_\_\_ CONFIRM ALL HOSES AND OTHER DRAIN PARTS HAVE A SLOPE IN DIRECTION OF WATER FLOW
  - \_\_\_\_\_ BOTH WORM DRIVES ON THE HOSE CLAMPS OF THE IDB COUPLING MUST BE LOCATED ON THE TOP OF THE COUPLING. SEE LOCATION DETAIL IN THE GENERAL CONVERSION INSTRUCTIONS AT THE BEGINNING OF THIS SECTION
  - \_\_\_\_\_ ALL CLAMPS AND COUPLINGS ARE TIGHTENED
  - \_\_\_\_\_ DOUBLE CHECK DIFFUSER IS INSTALLED IN INTAKE COUPLING
- 

## Notes:

# DOWN FLOW ZERO CLEARANCE

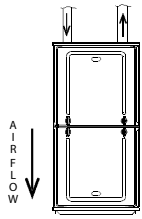

PARTS NEEDED FOR THIS CONVERSION REQUIRE ITEMS FROM THE **PARTS BAG**, CONVERSION KIT **RXGY-CK** AND **RXGY-ZK**. YOU MUST HAVE THE OUTLINED PARTS FROM THESE KITS BEFORE PROCEEDING.

## PARTS NEEDED:

FROM PARTS BAG (PROVIDED W/UNIT)

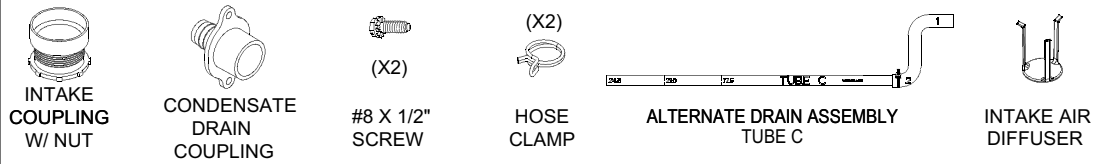

FROM CONVERSION KIT **RXGY-CK**

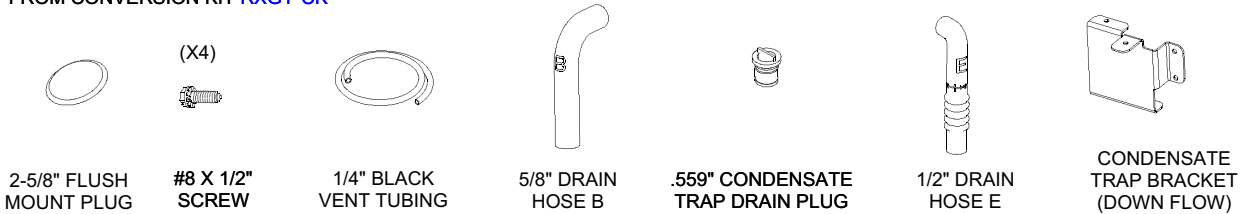

FROM ZERO-CLEARANCE CONVERSION KIT **RXGY-ZK**

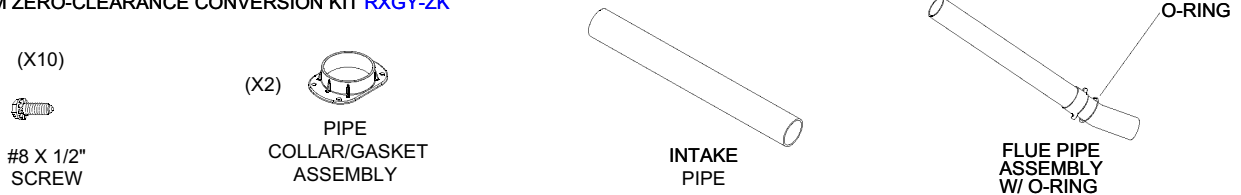

## TOOLS/MATERIALS NEEDED:

ELECTRIC DRILL  
1/8" DRILL BIT

3/16" DRILL BIT  
PLIERS

TUBING CUTTER  
1/4" HEX HEAD DRIVER  
5/16" HEX HEAD DRIVER

PVC GLUE AND PRIMER  
HAMMER  
FLAT HEAD SCREWDRIIVER

**NOTE: THESE CONVERSION INSTRUCTIONS ARE INTENTIONALLY GENERIC, SOME PARTS MAY BE DIFFERENT IN YOUR FURNACE**  
**NOTE: STEPS 1- 4 SHOWN WITH FURNACE IN "AS SHIPPED CONDITION"**

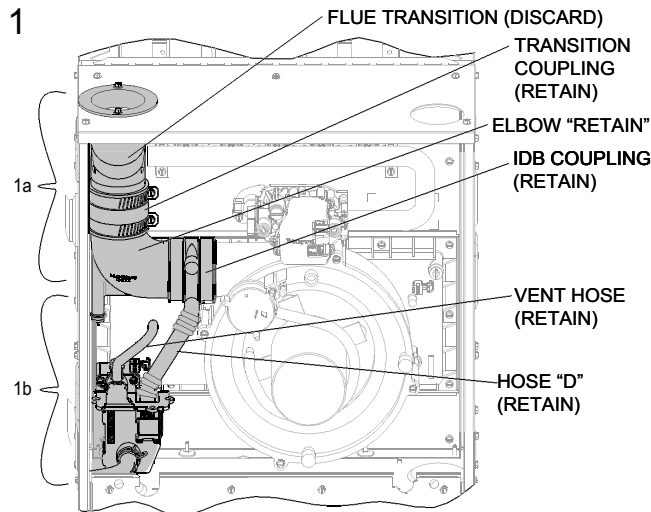

1a - REMOVE ELBOW, (2) COUPLINGS, AND FLUE TRANSITION. (RETAIN ELBOW AND COUPLINGS FOR LATER USE.) (NOTE: REMOVE COUPLING ON INDUCER WITH ELBOW FOR EASIER REMOVAL).

1b - REMOVE TRAP AND HOSES. RETAIN HOSE D FOR LATER USE. (NOTE: TO REMOVE TRAP REMOVE (2) SCREWS AND PULL STRAIGHT OUT).

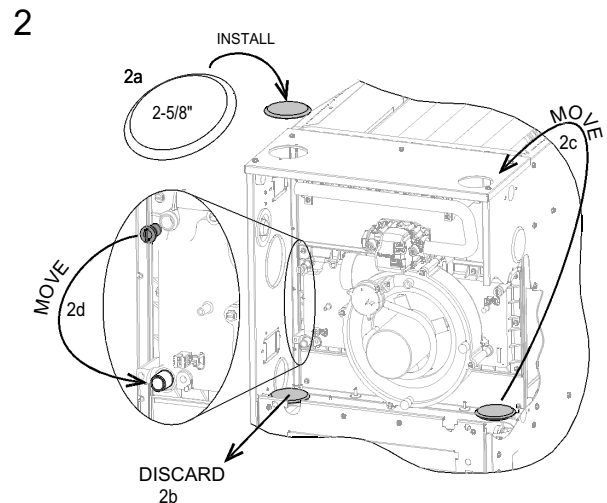

2a - INSTALL 2-5/8" FLUSH MOUNT PLUG.

2b - REMOVE LEFT 2-3/8" FLUSH PLUG IN BLOWER SHELF - DISCARD.

2c - RELOCATE RIGHT 2-3/8" FLUSH MOUNT PLUG FROM BLOWER SHELF TO TOP PLATE.

2d - RELOCATE .403" DRAIN PLUG IN THE COLLECTOR BOX.

ST-A1194-31-02

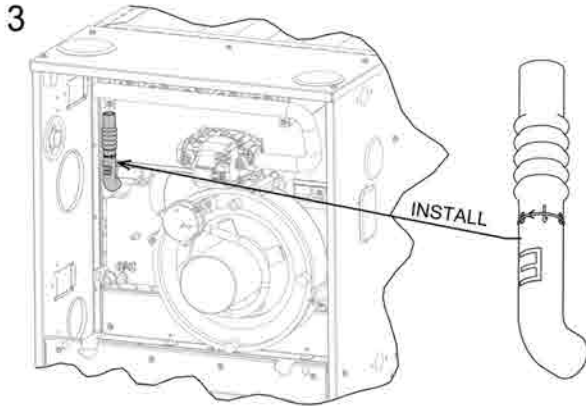

INSTALL HOSE E ON COLLECTOR BOX AS SHOWN. LET THE OPEN END HANG FREE UNTIL STEP 11.

**NOTE:**  
USE SOAPY WATER TO FACILITATE EASY HOSE AND TUBE ASSEMBLY

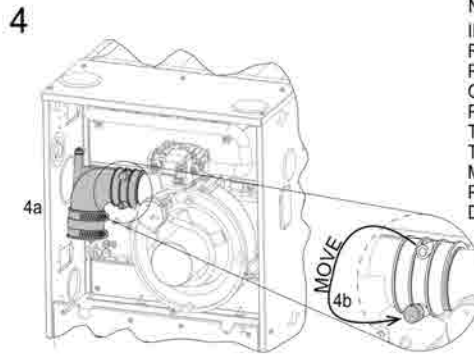

4a - RE-INSTALL ELBOW AND COUPLINGS (REMOVED IN STEP 1) IN THE ORIENTATION AS SHOWN.

4b - RELOCATE 1/2" VINYL CAP (YELLOW) ON INDUCER COUPLING TO OPPOSITE SIDE.

**NOTE:** LEAVE COUPLING CLAMP CONNECTIONS LOOSE UNTIL STEP 11.

**NOTE:**  
IF THE IDB COUPLING IS REMOVED, IT MUST BE REPLACED IN THE PROPER ORIENTATION. AN ARROW IS PRESENT ON THE COUPLING TO INDICATE THE DIRECTION OF EXHAUST FLOW. MAKE SURE THE ARROW POINTS IN THE CORRECT DIRECTION.

**NOTE: REMAINING STEPS SHOWN W/ FURNACE IN DOWN FLOW ORIENTATION**

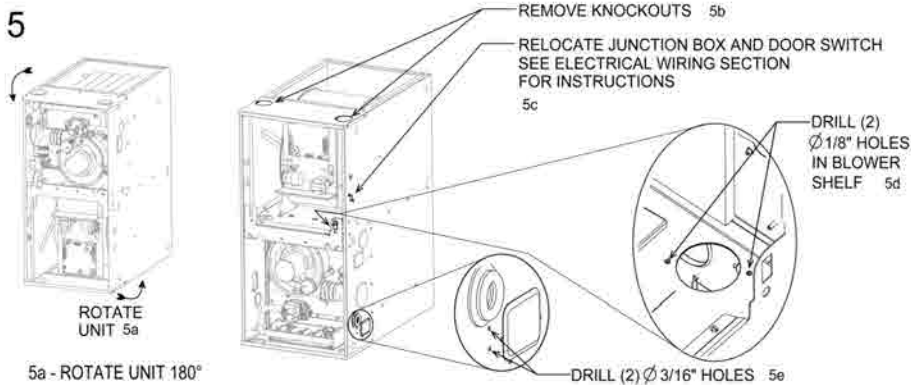

5a - ROTATE UNIT 180°

5b - REMOVE KNOCKOUTS WITH HAMMER AND FLAT HEAD SCREWDRIVER.

5c - THE JUNCTION BOX WILL HAVE TO BE RELOCATED FOR FLUE PIPE INSTALLATION. SEE ELECTRICAL WIRING SECTION FOR INSTRUCTIONS.

5d - RE-DRILL (2) Ø1/8" HOLES IN BLOWER SHELF AS SHOWN FOR FLUE PIPE ASSEMBLY.

5e - PRE-DRILL (2) Ø3/16" HOLES IN JACKET AS SHOWN FOR CONDENSATE TRAP BRACKET.

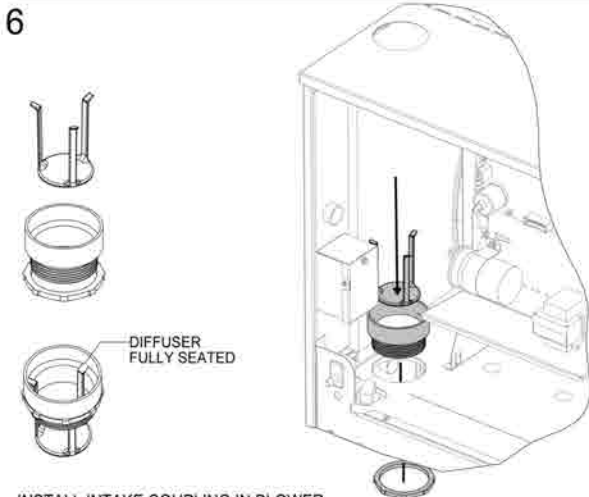

INSTALL INTAKE COUPLING IN BLOWER SHELF HOLE AS SHOWN. INSERT AIR DIFFUSER INTO COUPLING UNTIL TABS ARE SEATED.

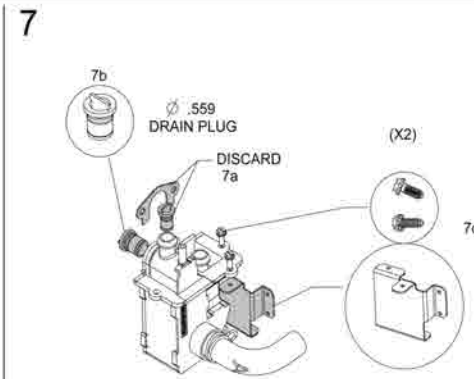

7a - REMOVE THE SMALL MOUNTING BRACKET AND THE .403" DRAIN PLUG - DISCARD.

7b - INSTALL .559" DRAIN PLUG IN CONDENSATE TRAP.

7c - INSTALL DOWN FLOW CONDENSATE TRAP BRACKET WITH (2) SCREWS AS SHOWN.

8

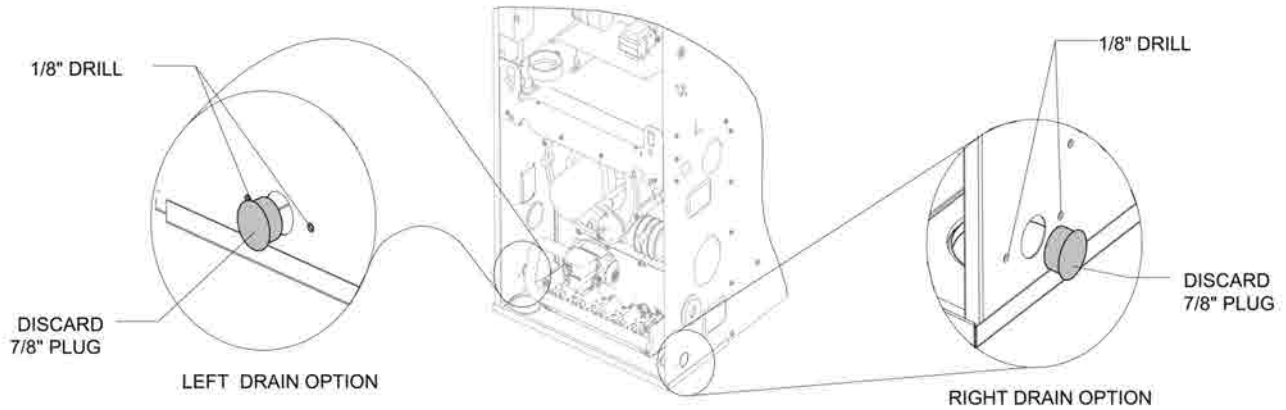

DETERMINE RIGHT OR LEFT DRAIN OPTION.  
 LOCATE 7/8" HOLE IN JACKET SIDE REMOVE PLUG - DISCARD.  
 DRILL (2)  $\varnothing$  1/8" HOLES FOR THE CONDENSATE DRAIN COUPLING.

9

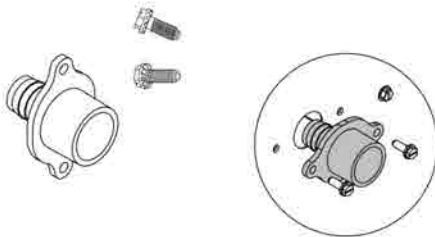

INSTALL CONDENSATE DRAIN COUPLING USING (2) SCREWS.  
 INSTALL IN JACKET WITH THE BARBED FITTING POINTED INTO THE VESTIBULE.

10

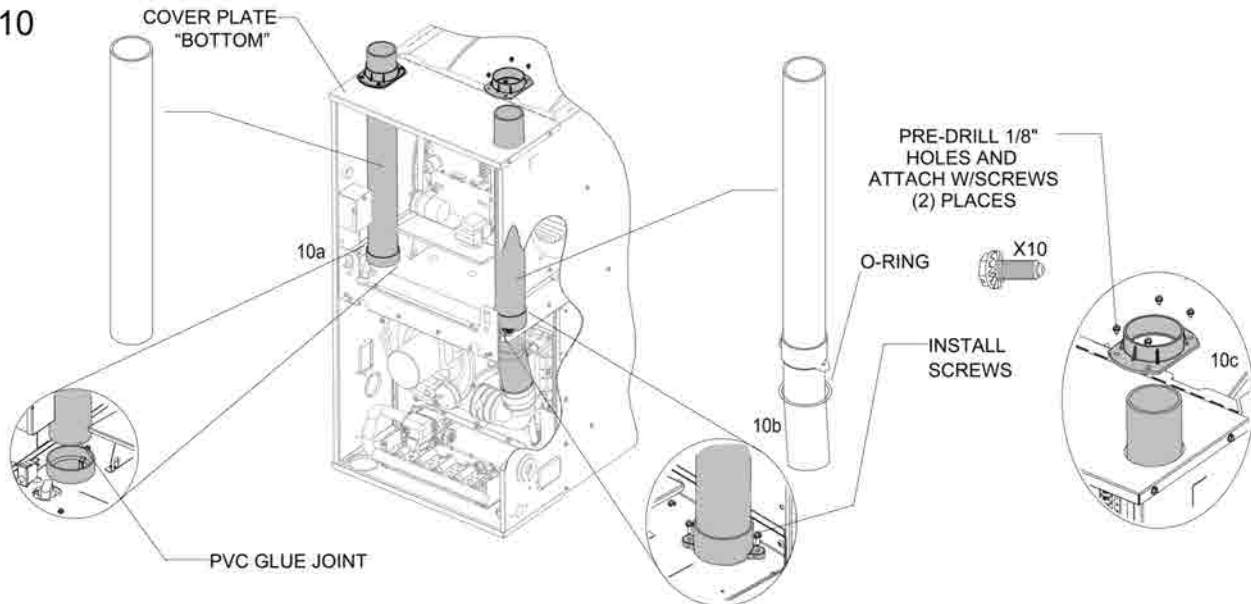

- 10a - INSTALL INTAKE PIPE  
 SLIDE INTAKE PIPE THROUGH THE LEFT SIDE KNOCKOUT ON COVER PLATE CLEAN AND PVC GLUE TO INTAKE COUPLING AS SHOWN
- 10b - INSTALL FLUE PIPE ASSEMBLY  
 INSERT FLUE PIPE ASSEMBLY THROUGH RIGHT SIDE KNOCKOUT ON COVER PLATE (NOTE: SLIDE FROM UNDER PLATE).  
 SLIDE ANGLED END THROUGH OPENING IN BLOWER SHELF AND ALIGN WITH ELBOW COUPLING.  
 SECURE PIPE ASSEMBLY TO BLOWER SHELF WITH (2) SCREWS AS SHOWN. ENSURE O-RING IS PROPERLY SEATED.
- 10c - SLIDE PIPE COLLAR ASSEMBLIES FROM STEP 7 OVER THE (2) PIPES AND DRILL (8)  $\varnothing$  1/8" HOLES USING THE COLLARS AS TEMPLATES. SECURE WITH SCREWS.

ST-A1194-31-02

# 11

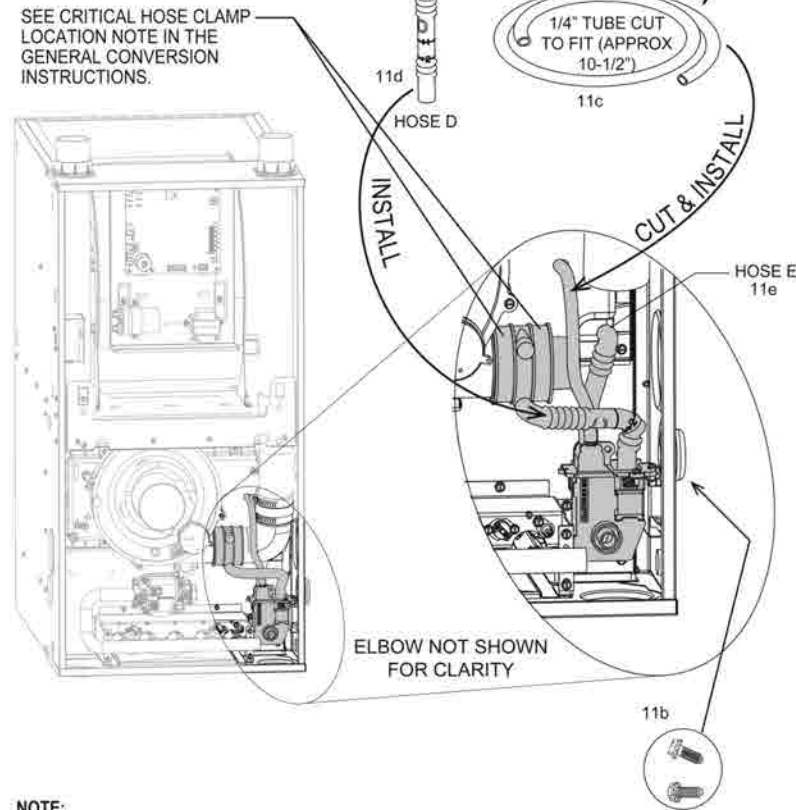

SEE CRITICAL HOSE CLAMP LOCATION NOTE IN THE GENERAL CONVERSION INSTRUCTIONS.

ELBOW NOT SHOWN FOR CLARITY

# 11a

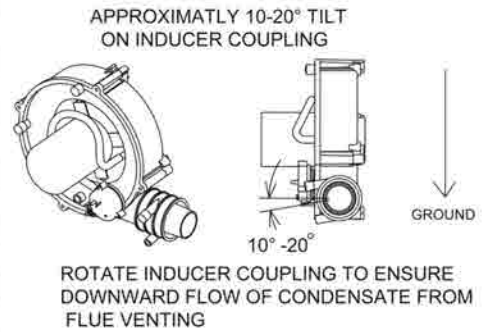

- 11a - ROTATE INDUCER COUPLING 10°  
! NOTE: TIGHTEN ELBOW COUPLING CLAMPS TO FLUE PIPE WITH 5/16" NUT DRIVER. (NOT SHOWN)
- 11b - INSTALL CONDENSATE TRAP BY MOUNTING BRACKET TO JACKET USING (2) SCREWS.
- 11c - CUT 1/4" VENT TUBE TO FIT (APPROX. 10-1/2"). INSTALL AS SHOWN.
- 11d - INSTALL HOSE D (REMOVED IN STEP 1) FROM TRANSITION COUPLING TO THE FLUE TAP ON THE CONDENSATE TRAP.
- 11e - ATTACH HOSE E TO THE TOP OF CONDENSATE TRAP.

**NOTE:**  
USE SOAPY WATER TO FACILITATE EASY HOSE AND TUBE ASSEMBLY

# 12a

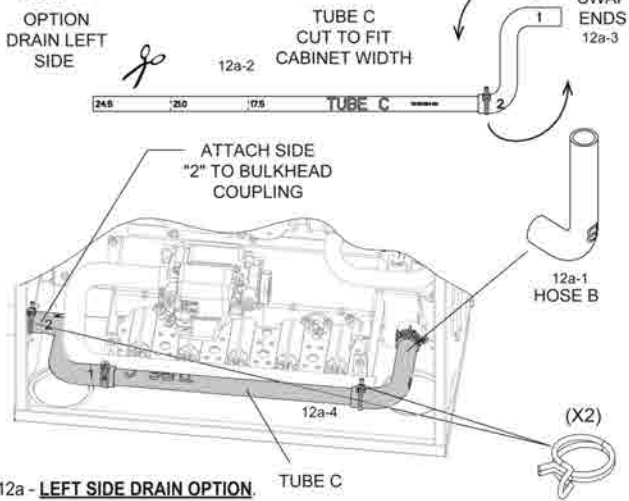

- 12a - **LEFT SIDE DRAIN OPTION.** TUBE C
- 12a-1 - REMOVE HOSE A (FACTORY INSTALLED) ON CONDENSATE TRAP & REPLACE WITH HOSE B REUSING SUPPLIED CLAMP.
- 12a-2 - CUT TUBE C ON MARKED LINES CORRESPONDING TO CABINET WIDTH.
- 12a-3 - ROTATE RUBBER HOSE ON TUBE C SO THAT SIDE "1" CONNECTS TO PVC & SIDE "2" TO BULKHEAD COUPLING. PLACE CLAMP OVER HOSE ON BULKHEAD COUPLING
- 12a-4 - INSTALL TUBE C USING HOSE CLAMP.

**NOTE:**  
USE SOAPY WATER TO FACILITATE EASY HOSE AND TUBE ASSEMBLY

# 12b

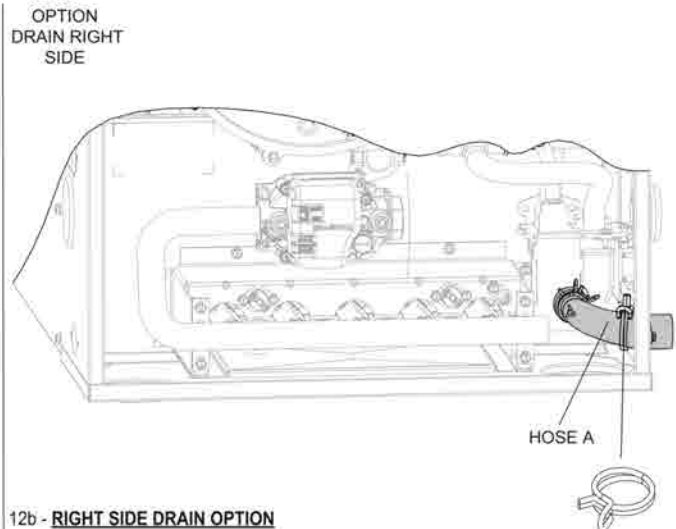

- 12b - **RIGHT SIDE DRAIN OPTION**
- 12b-1 - ATTACH HOSE A (FACTORY INSTALLED) TO BULKHEAD COUPLING. PLACE CLAMP OVER HOSE ON BULK HEAD COUPLING.

**NOTE:**  
USE SOAPY WATER TO FACILITATE EASY HOSE AND TUBE ASSEMBLY

## Checklist:

- \_\_\_ VERIFY ALL HOSES ARE SECURE AND FULLY SEATED.
- \_\_\_ CONFIRM THAT ALL HOSES ARE FREE OF KINKS.
- \_\_\_ CONFIRM ALL HOSES AND OTHER DRAIN PARTS HAVE A SLOPE IN DIRECTION OF WATER FLOW.
- \_\_\_ BOTH WORM DRIVES ON THE HOSE CLAMPS OF THE IDB COUPLING MUST BE LOCATED ON THE TOP OF THE COUPLING. SEE LOCATION DETAIL IN THE GENERAL CONVERSION INSTRUCTIONS AT THE BEGINNING OF THIS SECTION.
- \_\_\_ ALL DRAIN PORTS ARE PLUGGED.
- \_\_\_ UNIT HAS FORWARD PITCH.
- \_\_\_ HEAT TAPE INSTALLED(IF REQUIRED).
- \_\_\_ ALL CLAMPS AND COUPLINGS ARE TIGHTENED

---

## Notes:

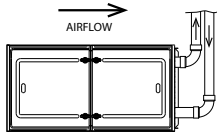

# HORIZONTAL RIGHT / RIGHT VENT



PARTS NEEDED FOR THIS CONVERSION REQUIRE ITEMS FROM THE **PARTS BAG** AND CONVERSION KIT **RXGY-CK**. YOU MUST HAVE THE PARTS OUTLINED BELOW BEFORE PROCEEDING.

## PARTS NEEDED:

FROM PARTS BAG (PROVIDED WITH UNIT)



INTAKE COUPLING AND NUT

FROM CONVERSION KIT **RXGY-CK**

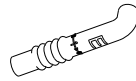

1/2" DRAIN HOSE E

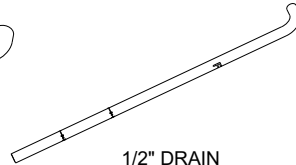

1/2" DRAIN HOSE F

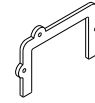

CONDENSATE TRAP GASKET

(X3)



#8 X 1/2" SCREW

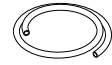

1/4" BLACK VENT TUBE

## TOOLS/MATERIALS NEEDED:

ELECTRIC DRILL  
1/8" DRILL BIT

PLIERS  
FLAT HEAD SCREWDRIVER

5/16 HEX HEAD DRIVER  
1/4" HEX HEAD DRIVER

NOTE: THESE CONVERSION INSTRUCTIONS ARE INTENTIONALLY GENERIC, SOME PARTS MAY BE DIFFERENT IN YOUR FURNACE  
NOTE: STEPS 1- 5 SHOWN WITH FURNACE IN "AS SHIPPED CONDITION"

1

- 1a - REMOVE TRAP AND HOSES  
**(NOTE: TO REMOVE TRAP, REMOVE (2) SCREWS AND PULL STRAIGHT OUT)**
- 1b - INSTALL INTAKE COUPLING IN TOP PLATE AS SHOWN.

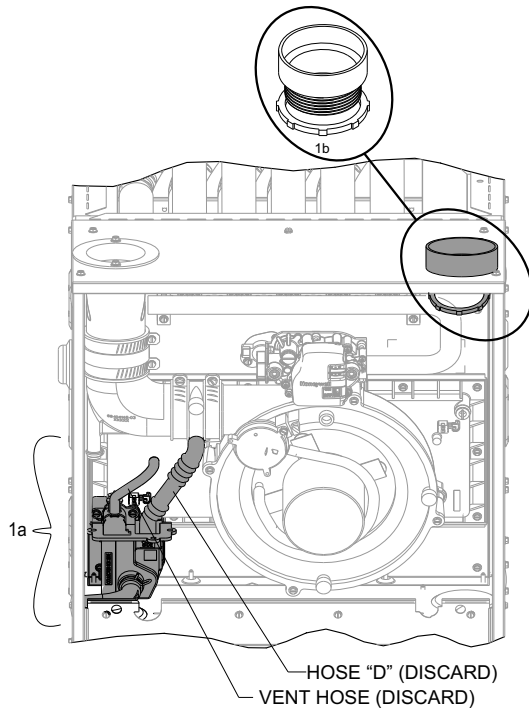

2

- 2a - RELOCATE 1/2" VINYL CAP (YELLOW) ON THE INDUCER COUPLING
- 2b - RELOCATE THE .403" DRAIN PLUG IN THE COLLECTOR BOX.
- 2c - RELOCATE 1/4" VINYL CAP (YELLOW) ON COLLECTOR BOX VENT TAP.

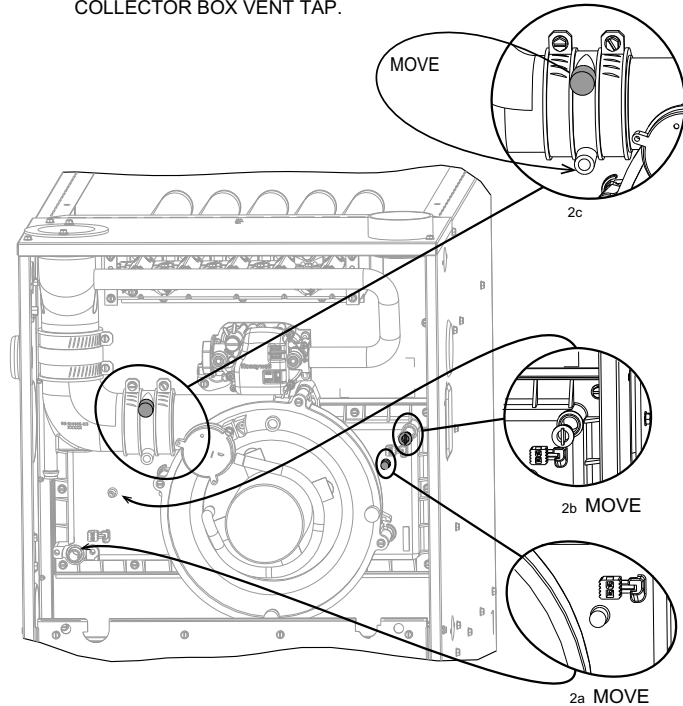

3

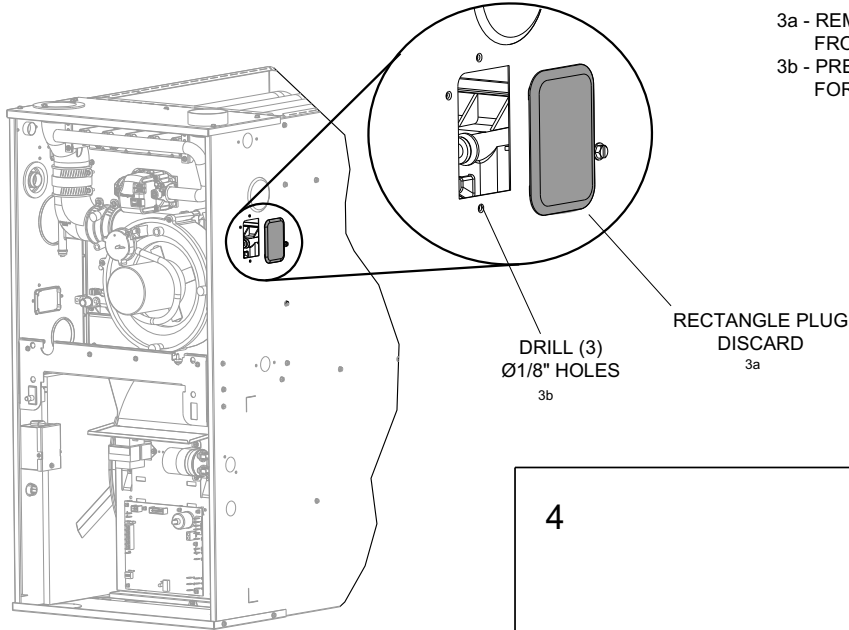

- 3a - REMOVE RECTANGLE FLUSH MOUNT PLUG FROM JACKET SIDE-DISCARD
- 3b - PRE-DRILL (3) Ø 1/8" HOLES AS SHOWN FOR CONDENSATE TRAP

DRILL (3)  
Ø1/8" HOLES  
3b

RECTANGLE PLUG  
DISCARD  
3a

4

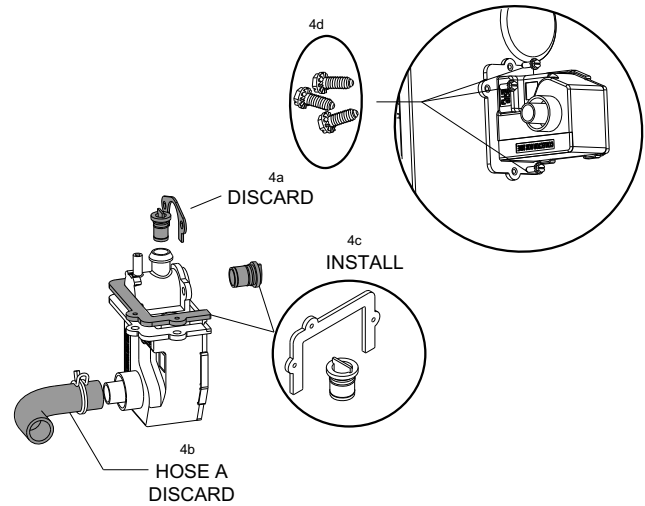

- 4a - REMOVE METAL BRACKET AND THE Ø.403 DRAIN PLUG- DISCARD.
- 4b - REMOVE HOSE A - DISCARD
- 4c - INSTALL Ø .559" CONDENSATE DRAIN PLUG AND CONDENSATE TRAP GASKET AS SHOWN.
- 4d - INSTALL CONDENSATE TRAP IN JACKET USING (3) SCREWS.

**NOTE:**  
TO PREVENT DAMAGE TO THE TRAP, THE INSTALLER MAY ELECT TO INSTALL IT DURING A LATER STEP. (AFTER THE UNIT IS ROTATED)

**NOTE: REMAINING STEPS SHOWN WITH FURNACE IN HORIZONTAL RIGHT ORIENTATION**

5

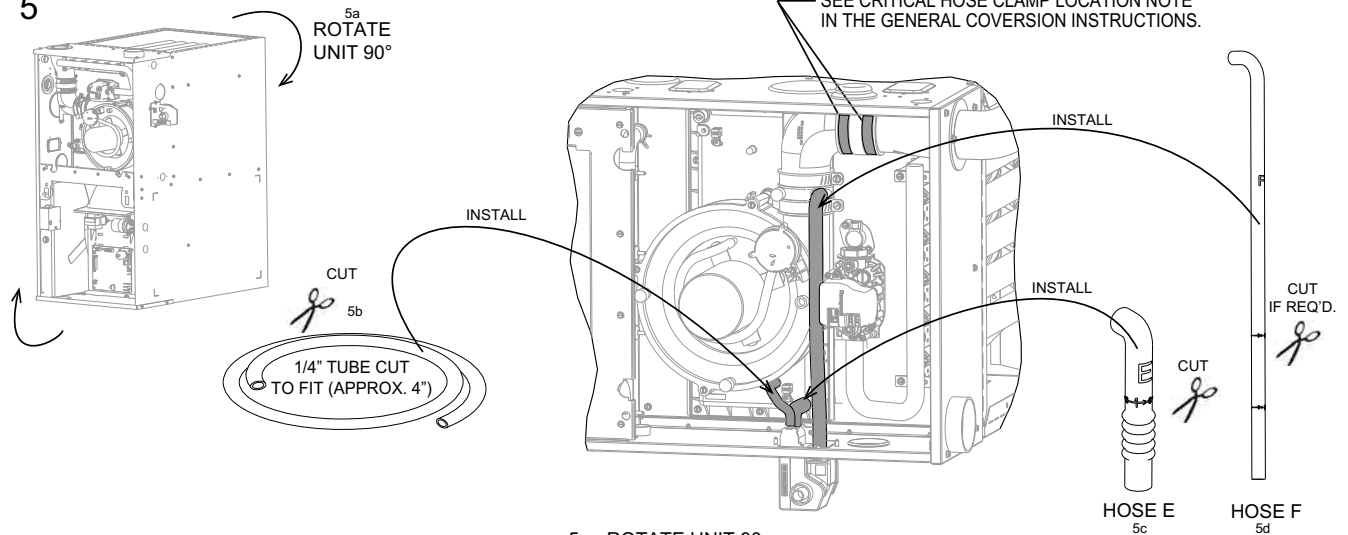

**NOTE:**  
USE SOAPY WATER TO FACILITATE EASY HOSE AND TUBE ASSEMBLY

- 5a - ROTATE UNIT 90
  - 5b - CUT 1/4" VENT HOSE TO FIT (APPROX. 5-1/2") AND INSTALL AS SHOWN.
  - 5c - CUT HOSE E AT LINE 1- INSTALL
  - 5d - CUT HOSE F ON LINE CORRESPONDING TO UNIT WIDTH AND INSTALL
- NOTE: MAKE SURE CUT IS STRAIGHT AND SQUARE**  
**NOTE: 17.5": LINE 1, 21": LINE 2, 24.5": DO NOT CUT**

ST-A1194-32-01

Field Conversions



## Checklist:

- \_\_\_\_\_ VERIFY ALL HOSES ARE SECURE AND FULLY SEATED.
  - \_\_\_\_\_ CONFIRM THAT ALL HOSES ARE FREE OF KINKS.
  - \_\_\_\_\_ CONFIRM ALL HOSES AND OTHER DRAIN PARTS HAVE A SLOPE IN DIRECTION OF WATER FLOW.
  - \_\_\_\_\_ BOTH WORM DRIVES ON THE HOSE CLAMPS OF THE FLUE TRANSITION MUST BE LOCATED ON THE TOP OF THE COUPLING. SEE LOCATION DETAIL IN THE GENERAL CONVERSION INSTRUCTIONS AT THE BEGINNING OF THIS SECTION.
  - \_\_\_\_\_ ALL CLAMPS AND COUPLINGS ARE TIGHTENED
  - \_\_\_\_\_ ALL DRAIN PORTS ARE PLUGGED.
  - \_\_\_\_\_ UNIT HAS FORWARD PITCH.
  - \_\_\_\_\_ HEAT TAPE INSTALLED(IF REQUIRED)
- 

## Notes:

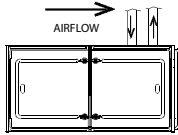

# HORIZONTAL RIGHT / VERTICAL VENT

## PARTS NEEDED:



PARTS NEEDED FOR THIS CONVERSION REQUIRE ITEMS FROM THE **PARTS BAG** AND CONVERSION KIT **RXGY-CK**. YOU MUST HAVE THE PARTS OUTLINED BELOW BEFORE PROCEEDING.

FROM PARTS BAG  
(PROVIDED WITH UNIT)



FROM CONVERSION KIT **RXGY-CK**

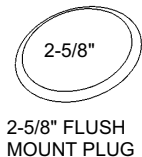
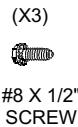
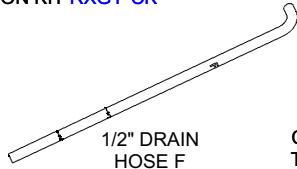

## TOOLS/MATERIALS NEEDED:

ELECTRIC DRILL  
1/8" DRILL BIT

PLIERS  
FLAT HEAD SCREWDRIVER

5/16 HEX HEAD DRIVER  
1/4" HEX HEAD DRIVER

TUBING CUTTER

**NOTE: THESE CONVERSION INSTRUCTIONS ARE INTENTIONALLY GENERIC, SOME PARTS MAY BE DIFFERENT IN YOUR FURNACE**  
**NOTE: STEPS 1- 5 SHOWN WITH FURNACE IN "AS SHIPPED CONDITION"**

1

- 1a - REMOVE FLUE TRANSITION, TRANSITION COUPLING, AND ELBOW.  
(NOTE: REMOVE INDUCER COUPLING W/ ELBOW FOR EASIER REMOVAL).  
1b - REMOVE CONDENSATE TRAP AND HOSES.  
(NOTE: TO REMOVE TRAP REMOVE (2) SCREWS AND PULL STRAIGHT OUT).

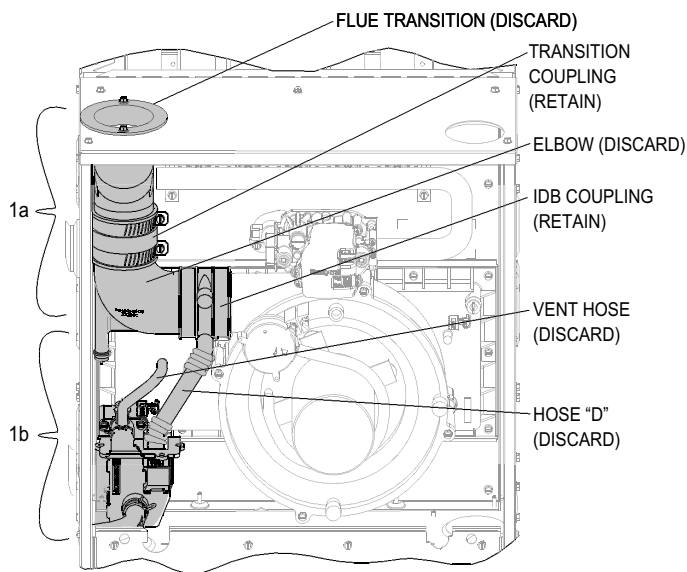

2

- 2a - RELOCATE 1/2" VINYL CAP (YELLOW) ON THE INDUCER COUPLING.  
2b - REMOVE 3-3/8" FLUSH MOUNT PLUG FROM JACKET SIDE-DISCARD.  
2c - REMOVE IDB COUPLING AND ELBOW.  
2d - INSTALL 2-5/8" FLUSH MOUNT PLUG IN TOP PLATE.

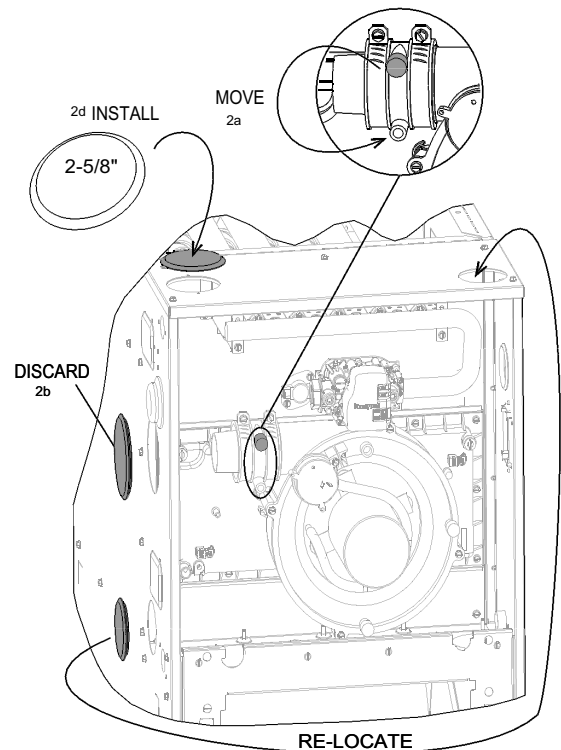

NOTE:  
IF THE IDB COUPLING IS REMOVED, IT MUST BE REPLACED IN THE PROPER ORIENTATION. AN ARROW IS PRESENT ON THE COUPLING TO INDICATE THE DIRECTION OF EXHAUST FLOW. MAKE SURE THE ARROW POINTS IN THE CORRECT DIRECTION.

ST-A1194-33-01

3

- 3a - RELOCATE THE Ø .403" DRAIN PLUG IN THE COLLECTOR BOX.
- 3b - RELOCATE 1/4" VINYL CAP (YELLOW) ON COLLECTOR BOX VENT TAP.

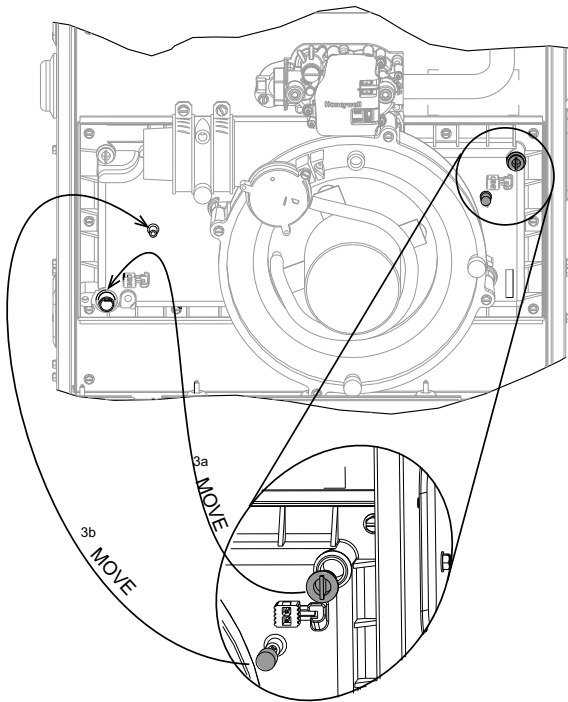

4

- 4a - REMOVE RECTANGLE FLUSH MOUNT PLUG FROM JACKET SIDE - DISCARD
- 4b - PRE-DRILL (3) Ø1/8" HOLES AS SHOWN FOR CONDENSATE TRAP
- 4c - INSTALL 2" PIPE GROMMET IN JACKET
- 4d - SLIDE AIR DIFFUSER INTO INTAKE COUPLING AND INSTALL INTO JACKET AS SHOWN.

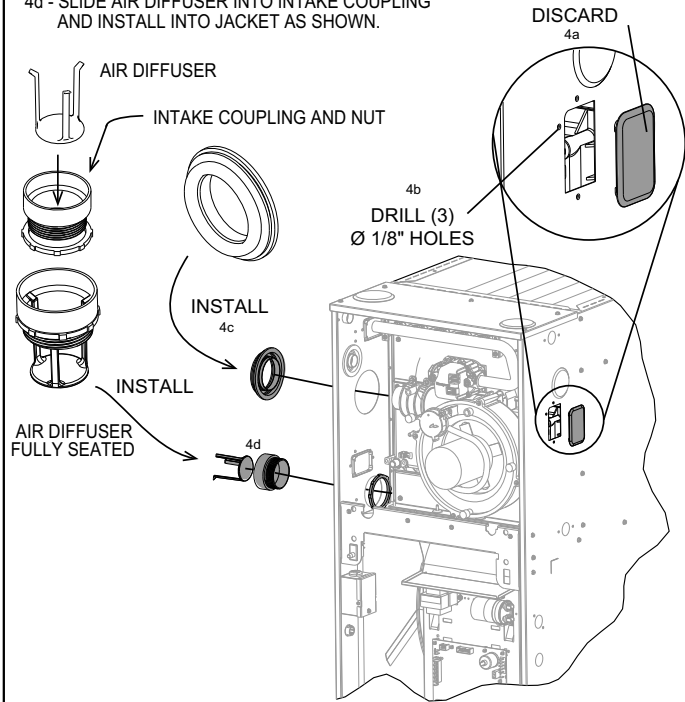

5

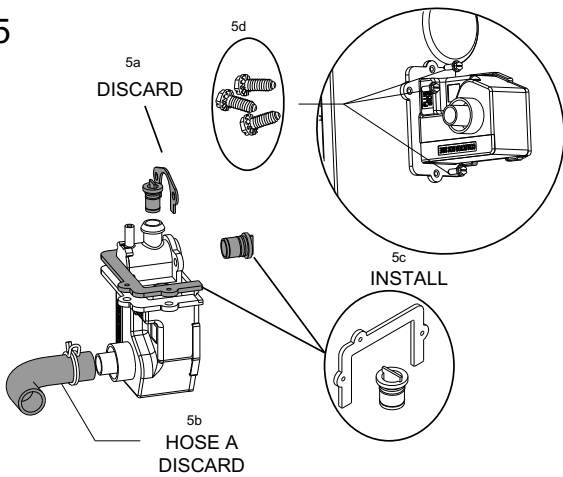

**NOTE:**  
TO PREVENT DAMAGE TO THE TRAP, THE INSTALLER  
MAY ELECT TO INSTALL IT DURING A LATER STEP.  
(AFTER THE UNIT IS ROTATED)

- 5a - REMOVE METAL BRACKET AND THE Ø.403" DRAIN PLUG- DISCARD.
- 5b - REMOVE HOSE A - DISCARD
- 5c - INSTALL Ø .559" CONDENSATE DRAIN PLUG AND CONDENSATE TRAP GASKET AS SHOWN.
- 5d - INSTALL CONDENSATE TRAP IN JACKET USING (3) SCREWS.

NOTE: REMAINING STEPS SHOWN WITH FURNACE IN HORIZONTAL RIGHT ORIENTATION

6

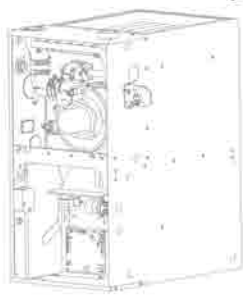

6a  
ROTATE  
UNIT 90°

6a - ROTATE UNIT 90°

6b - CUT 1/4" VENT HOSE TO FIT (APPROX. 5-1/2") AND INSTALL AS SHOWN

6c - CUT HOSE E AT LINE 1- INSTALL

NOTE: MAKE SURE CUT IS STRAIGHT AND SQUARE

6d - CUT HOSE F ON LINE CORRESPONDING TO UNIT WIDTH AND INSTALL

NOTE: 17.5": LINE 1, 21": LINE 2, 24.5": DO NOT CUT

NOTE:  
USE SOAPY WATER TO FACILITATE EASY  
HOSE AND TUBE ASSEMBLY

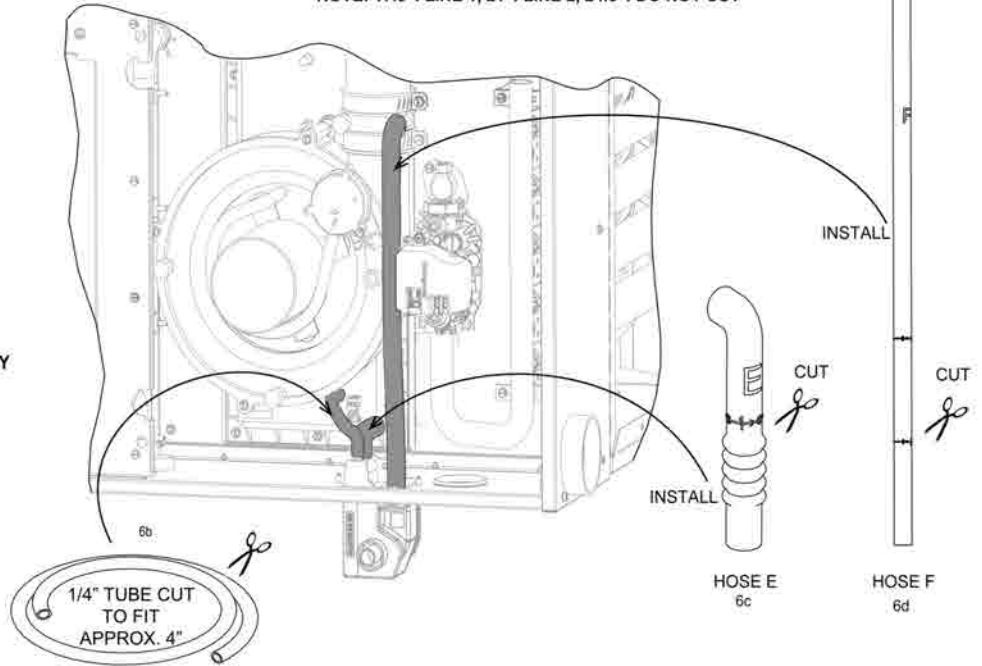

## Checklist:

- \_\_\_ VERIFY ALL HOSES ARE SECURE AND FULLY SEATED.
- \_\_\_ CONFIRM THAT ALL HOSES ARE FREE OF KINKS
- \_\_\_ CONFIRM ALL HOSES AND OTHER DRAIN PARTS HAVE A SLOPE IN DIRECTION OF WATER FLOW
- \_\_\_ ALL CLAMPS AND COUPLINGS ARE TIGHTENED
- \_\_\_ ALL DRAIN PORTS ARE PLUGGED
- \_\_\_ UNIT HAS FORWARD PITCH
- \_\_\_ HEAT TAPE INSTALLED(IF REQUIRED)

Notes:

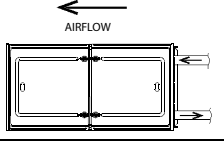

# HORIZONTAL LEFT / RIGHT VENT



PARTS NEEDED FOR THIS CONVERSION REQUIRE ITEMS FROM THE PARTS BAG, CONVERSION KIT **RXGY-CK** AND **RXGY-ZK**. YOU MUST HAVE THE PARTS OUTLINED BELOW FROM THESE KITS BEFORE PROCEEDING.

## PARTS NEEDED:

FROM PARTS BAG (PROVIDED WITH UNIT)



INTAKE COUPLING AND NUT



INTAKE AIR DIFFUSER

FROM CONVERSION KIT **RXGY-CK**

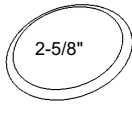

2-5/8" FLUSH MOUNT PLUG

(X4)



#8 X 1/2" SCREW



1/4" BLACK VENT TUBE



.559" CONDENSATE TRAP DRAIN PLUG

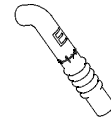

1/2" DRAIN HOSE E



1/2" VINYL CAP (YELLOW)

FROM CONVERSION KIT **RXGY-ZK**

(X10)



#8 X 1/2" SCREW

(X2)



PIPE COLLAR / GASKET ASSEMBLY

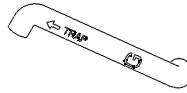

1/2" DRAIN HOSE G

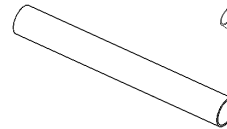

INTAKE PIPE

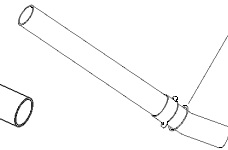

FLUE PIPE ASSEMBLY W/ O-RING

O-RING

## TOOLS/MATERIALS NEEDED:

ELECTRIC DRILL

1/8" DRILL BIT  
HAMMER

3/16" DRILL BIT  
FLAT HEAD SCREWDRIVER

PLIERS

1/4" HEX HEAD DRIVER  
TUBING CUTTER

5/16" HEX HEAD DRIVER

NOTE: THESE CONVERSION INSTRUCTIONS ARE INTENTIONALLY GENERIC, SOME PARTS MAY BE DIFFERENT IN YOUR FURNACE.  
NOTE: STEPS 1-4 SHOWN WITH FURNACE IN "AS SHIPPED CONDITION"

Field Conversions

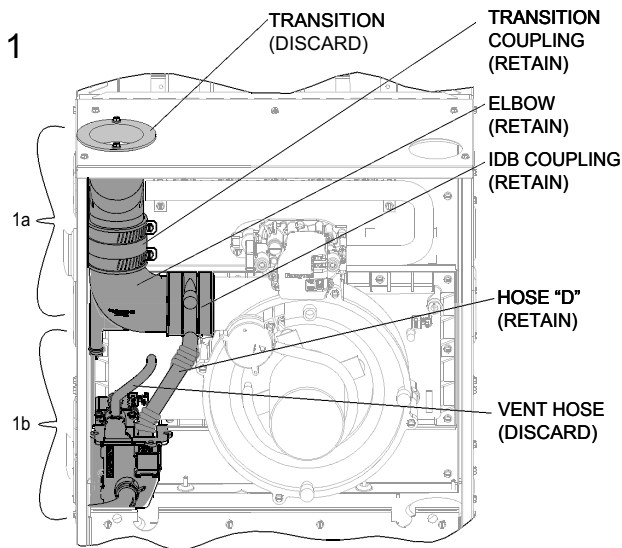

- 1a - REMOVE ELBOW, (2) COUPLINGS, AND FLUE TRANSITION. **NOTE: RETAIN ELBOW AND COUPLINGS FOR LATER USE.**  
1b - REMOVE TRAP AND HOSES. RETAIN HOSE D FOR LATER USE. **NOTE: TO REMOVE TRAP REMOVE (2) SCREWS AND PULL STRAIGHT OUT**

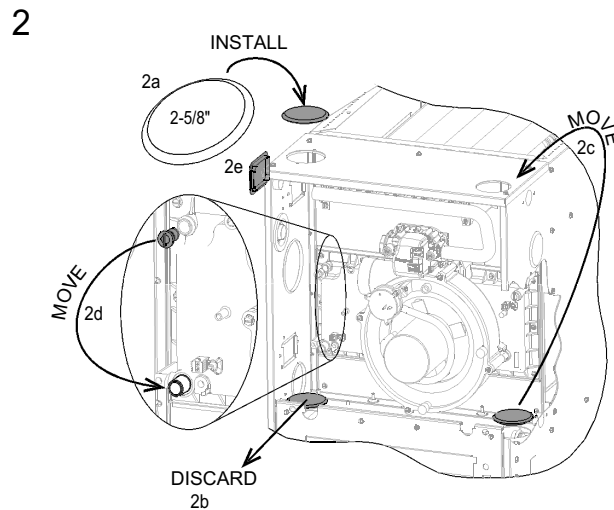

- 2a - INSTALL 2-5/8" FLUSH MOUNT PLUG.  
2b - REMOVE LEFT 2-3/8" FLUSH PLUG IN BLOWER SHELF - DISCARD.  
2c - RELOCATE RIGHT 2-3/8" FLUSH MOUNT PLUG FROM BLOWER SHELF TO TOP PLATE.  
2d - RELOCATE Ø.403" DRAIN PLUG IN THE COLLECTOR BOX.  
2e - REMOVE RECTANGLE FLUSH MOUNT PLUG-DISCARD

ST-A1194-34-01

3

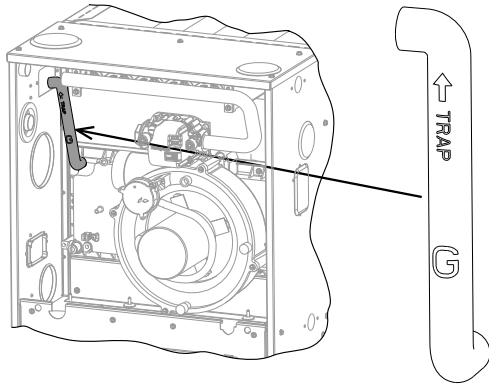

INSTALL HOSE G ON COLLECTOR BOX AS SHOWN.  
NOTE: LET THE OPEN END HANG FREE UNTIL STEP 10.

4

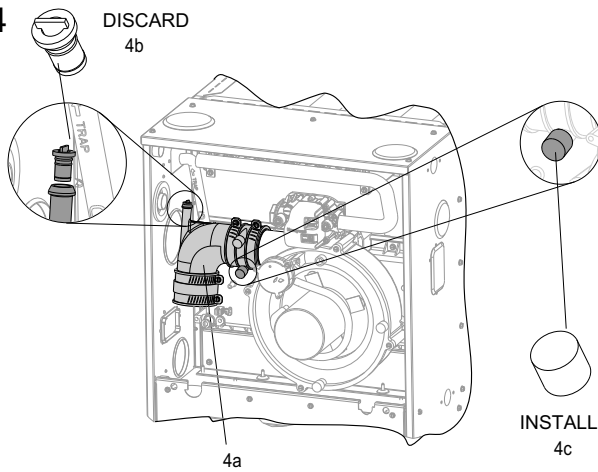

4a - RE-INSTALL ELBOW AND COUPLINGS (FROM STEP 1)  
IN THE ORIENTATION AS SHOWN.  
4b - REMOVE Ø .403" DRAIN PLUG FROM ELBOW DRAIN  
PORT - DISCARD.  
4c - INSTALL 1/2" VINYL CAP (YELLOW) ON INDUCER COUPLING.  
NOTE: LEAVE COUPLING CLAMP CONNECTIONS LOOSE UNTIL STEP 10.

NOTE:  
IF THE IDB COUPLING IS REMOVED, IT MUST BE REPLACED IN THE  
PROPER ORIENTATION. AN ARROW IS PRESENT ON THE COUPLING  
TO INDICATE THE DIRECTION OF EXHAUST FLOW. MAKE SURE THE  
ARROW POINTS IN THE CORRECT DIRECTION.

5

NOTE: STEPS 5 - 7 SHOWN WITH FURNACE IN DOWNFLOW ORIENTATION

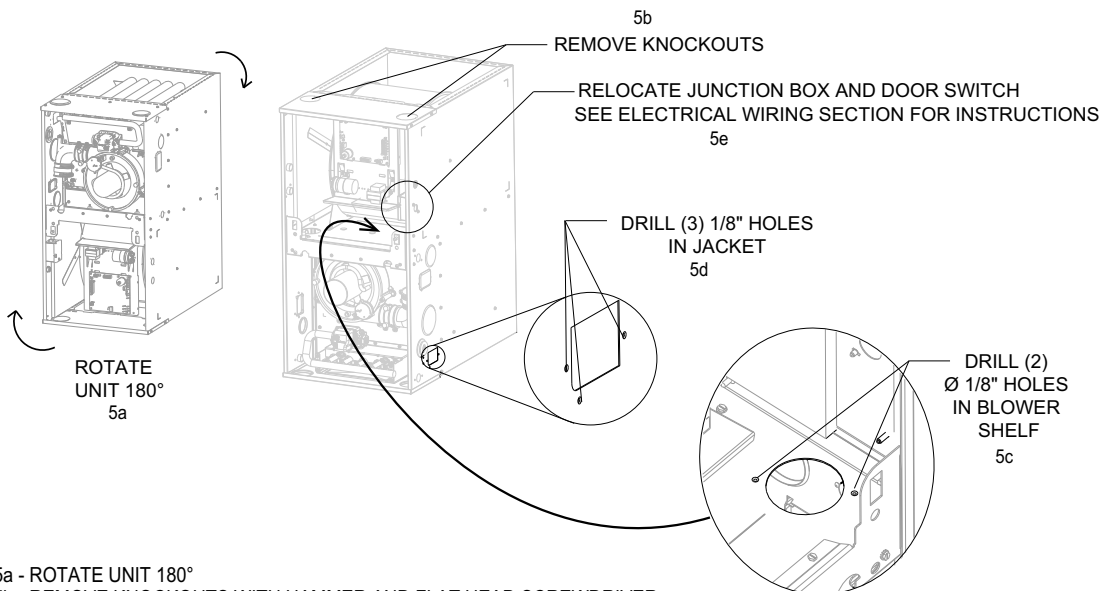

5a - ROTATE UNIT 180°  
5b - REMOVE KNOCKOUTS WITH HAMMER AND FLAT HEAD SCREWDRIVER.  
5c - PRE-DRILL (2) Ø 1/8" HOLES IN BLOWER SHELF AS SHOWN FOR FLUE PIPE ASSEMBLY.  
5d - PRE-DRILL (3) Ø 1/8" HOLES IN JACKET AS SHOWN FOR CONDENSATE TRAP.  
5e - THE JUNCTION BOX WILL HAVE TO BE RELOCATED FOR FLUE PIPE INSTALLATION  
NOTE: SEE ELECTRICAL WIRING SECTION FOR INSTRUCTIONS.

6

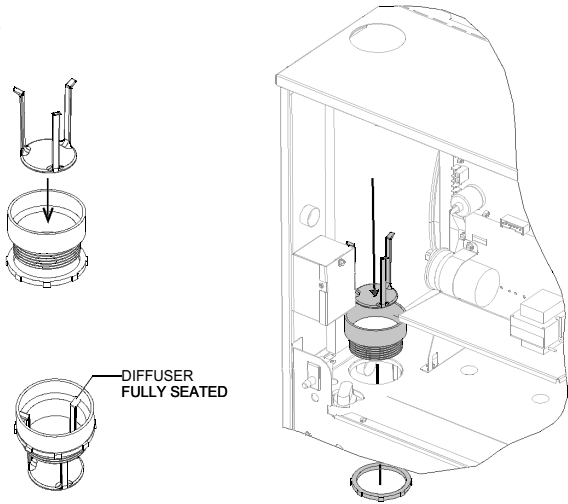

INSTALL INTAKE COUPLING IN BLOWER SHELF HOLE AS SHOWN.  
INSERT AIR DIFFUSER INTO COUPLING UNTIL TABS ARE SEATED.

**NOTE:**  
DIFFUSER MAY HAVE A TENDENCY TO FALL OUT OF THE COUPLING AT THIS STEP. THE INSTALLER MAY ELECT TO INSTALL THE DIFFUSER AFTER ROTATING THE FURNACE TO THE HORIZONTAL POSITION.

7

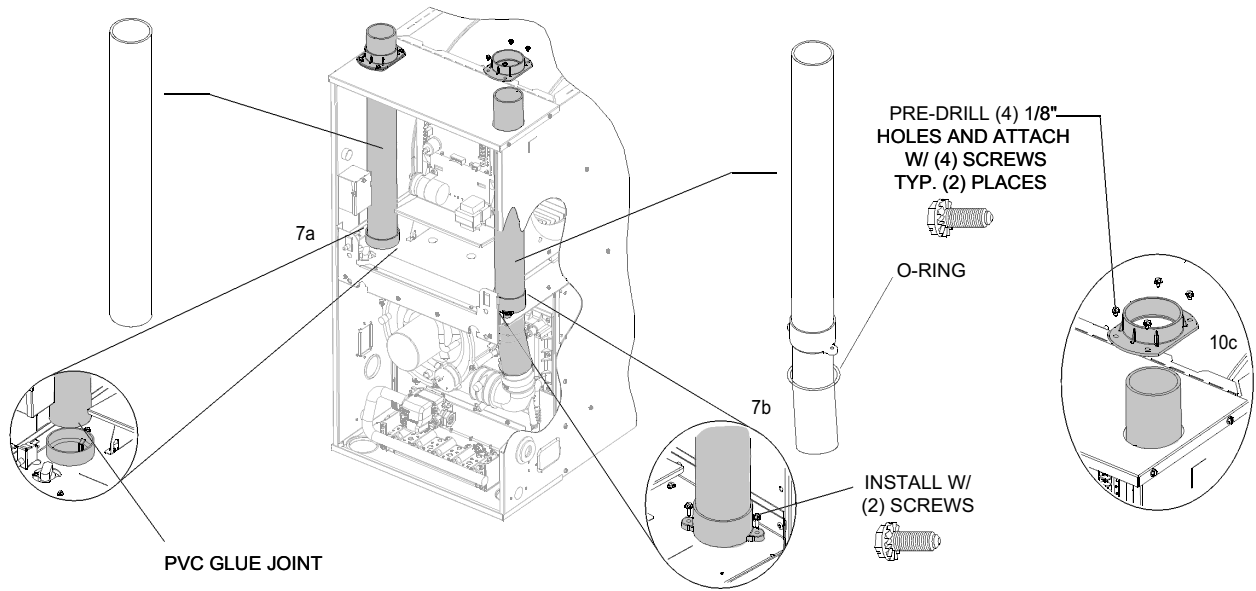

Field Conversions

- 7a - **INSTALL INTAKE PIPE:** SLIDE INTAKE PIPE THROUGH THE LEFT SIDE KNOCKOUT, CLEAN AND PVC GLUE TO INTAKE COUPLING AS SHOWN.
- 7b - **INSTALL FLUE PIPE ASSEMBLY:** INSERT FLUE PIPE ASSEMBLY THROUGH RIGHT SIDE KNOCKOUT, (NOTE: SLIDE FROM UNDER PLATE). SLIDE ANGLED END THROUGH OPENING IN BLOWER SHELF AND ALIGN WITH ELBOW COUPLING. SECURE PIPE ASSEMBLY TO BLOWER SHELF WITH (2) SCREWS AS SHOWN. ENSURE O-RING IS PROPERLY SEATED.
- 7c - SLIDE PIPE COLLAR ASSEMBLIES OVER THE (2) PIPES AND DRILL (8) Ø1/8" HOLES USING THE COLLARS AS A TEMPLATE. SECURE WITH (8) SCREWS AS SHOWN.

**NOTE: REMAINING STEPS SHOWN WITH FURNACE IN HORIZONTAL LEFT ORIENTATION**

8

ROTATE 90°



NOTE:  
TO PREVENT DAMAGE TO THE TRAP, THE INSTALLER MAY ELECT TO INSTALL IT DURING A LATER STEP. (AFTER THE UNIT IS ROTATED)

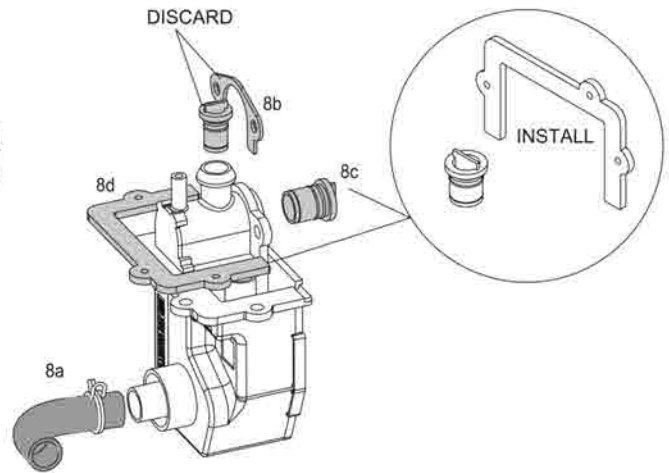

- 8a - REMOVE HOSE "A" FROM TRAP ASSEMBLY AND DISCARD.
- 8b - REMOVE THE SMALL MOUNTING BRACKET AND THE Ø .403" DRAIN PLUG - DISCARD.
- 8c - INSTALL Ø .559" DRAIN PLUG IN CONDENSATE TRAP.
- 8d - INSTALL CONDENSATE TRAP GASKET AS SHOWN.
- 8e - MOUNT THE TRAP IN JACKET SIDE, USING (3) SCREWS.
- 8f - ROTATE UNIT 90°

9

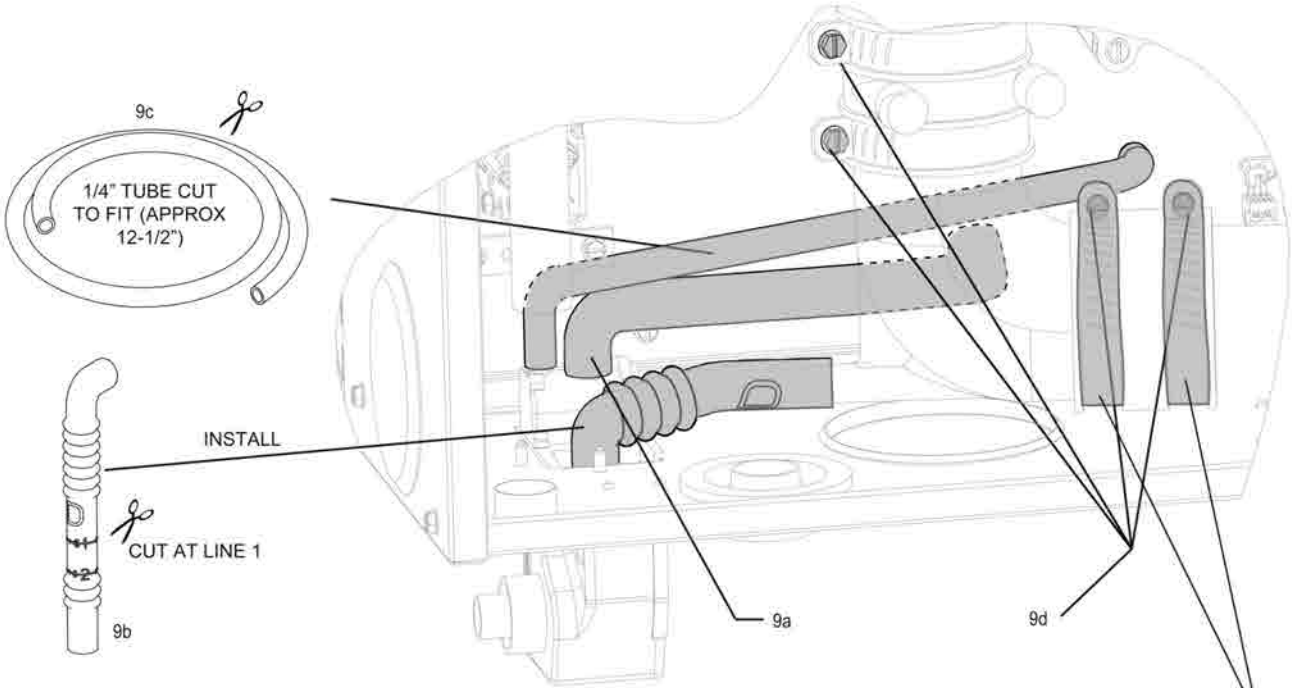

SEE CRITICAL HOSE CLAMP LOCATION NOTE IN THE GENERAL COVERSION INSTRUCTIONS.

- 9a - ATTACH HOSE G TO THE TOP OF CONDENSATE TRAP.
- 9b - LOCATE HOSE D (REMOVED IN STEP 1) - CUT ON LINE 1 - INSTALL  
NOTE: ROUTE FROM FLUE ELBOW TO FLUE SIDE TAP IN THE CONDENSATE TRAP.
- 9c - CUT 1/4" VENT TUBE TO FIT (APPROX. 12-1/2") AND INSTALL AS SHOWN.  
NOTE: ROUTE FROM COLLECTOR BOX TO TOP OF CONDENSATE TRAP
- 9d - TIGHTEN ELBOW AND INDUCER CLAMPS TO FLUE PIPE W/ 5/16" NUT DRIVER.

ST-A1194-34-01

---

## Checklist:

- \_\_\_\_ VERIFY ALL HOSES ARE SECURE AND FULLY SEATED.
- \_\_\_\_ CONFIRM THAT ALL HOSES ARE FREE OF KINKS.
- \_\_\_\_ CONFIRM ALL HOSES AND OTHER DRAIN PARTS HAVE A SLOPE IN DIRECTION OF WATER FLOW.
- \_\_\_\_ BOTH WORM DRIVES ON THE HOSE CLAMPS OF THE FLUE TRANSITION MUST BE LOCATED ON THE TOP OF THE COUPLING. SEE LOCATION DETAIL IN THE GENERAL CONVERSION INSTRUCTIONS AT THE BEGINNING OF THIS SECTION.
- \_\_\_\_ ALL CLAMPS AND COUPLINGS ARE TIGHTENED
- \_\_\_\_ ALL DRAIN PORTS ARE PLUGGED.
- \_\_\_\_ UNIT HAS FORWARD PITCH.
- \_\_\_\_ HEAT TAPE INSTALLED (IF REQUIRED)

---

## Notes:

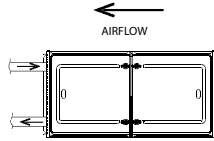

# HORIZONTAL LEFT / LEFT VENT

## PARTS NEEDED:

FROM PARTS BAG (PROVIDED WITH UNIT)



INTAKE COUPLING  
W/NUT

**!** PARTS NEEDED FOR THIS CONVERSION REQUIRE ITEMS FROM THE PARTS BAG AND CONVERSION KIT **RXGY-CK**. YOU MUST HAVE THE PARTS OUTLINED BELOW BEFORE PROCEEDING.

FROM CONVERSION KIT **RXGY-CK**



1/2" VINYL  
CAP (YELLOW)



.559" CONDENSATE  
TRAP DRAIN PLUG

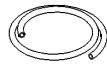

1/4" BLACK  
VENT TUBING

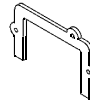

CONDENSATE  
TRAP GASKET

(X3)



#8 X 1/2"  
SCREW

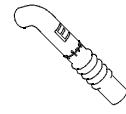

1/2" DRAIN  
HOSE E

## TOOLS/MATERIALS NEEDED:

ELECTRIC DRILL  
1/8" DRILL BIT

PLIERS  
1/4" HEX HEAD DRIVER

TUBE CUTTER

**NOTE: THESE CONVERSION INSTRUCTIONS ARE INTENTIONALLY GENERIC, SOME PARTS MAY BE DIFFERENT IN YOUR FURNACE**  
**NOTE: STEPS 1- 4 SHOWN WITH FURNACE IN "AS SHIPPED CONFIGURATION"**

1

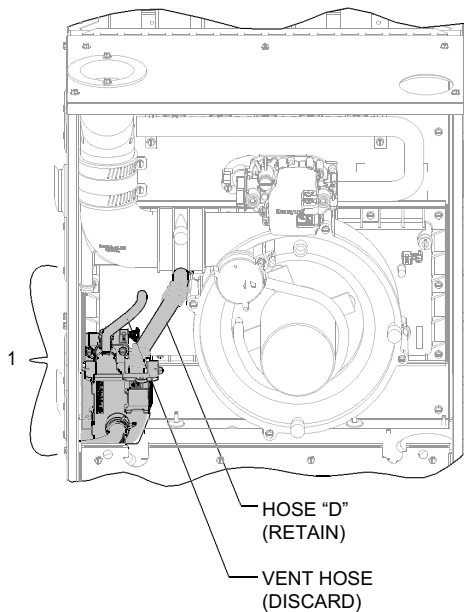

1 - REMOVE CONDENSATE TRAP AND HOSES.  
(RETAIN HOSE D FOR LATER USE.)

**(NOTE: TO REMOVE TRAP, REMOVE (2) SCREWS AND PULL STRAIGHT OUT).**

2

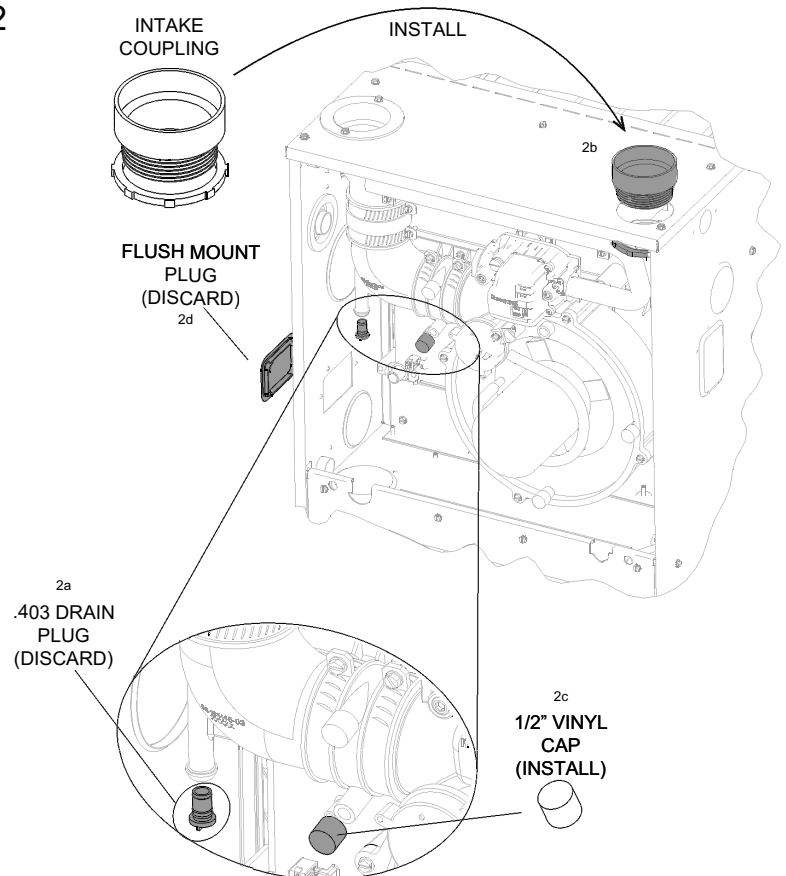

2a - REMOVE .403" DRAIN PLUG FROM FLUE ELBOW - DISCARD.

2b - INSTALL INTAKE COUPLING IN TOP PLATE.

2c - INSTALL 1/2" VINYL CAP (YELLOW) IN INDUCER COUPLING AS SHOWN.

2d - REMOVE RECTANGLE FLUSH MOUNT PLUG FROM JACKET SIDE-DISCARD.

Field Conversions

ST-A1194-35-X0

3

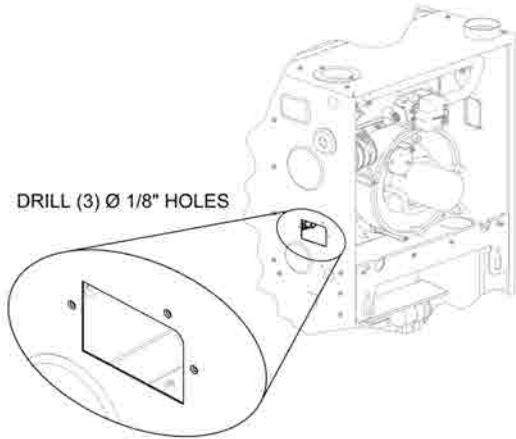

DRILL (3) Ø 1/8" HOLES

PRE-DRILL (3) Ø 1/8" HOLES AS SHOWN FOR CONDENSATE TRAP.

4

- 4a - REMOVE METAL BRACKET AND .403" DRAIN PLUG - DISCARD.
- 4b - REMOVE HOSE A - DISCARD
- 4c - INSTALL Ø.559" CONDENSATE DRAIN PLUG
- 4d - CONDENSATE TRAP GASKET AS SHOWN
- 4e - INSTALL CONDENSATE TRAP IN JACKET USING (3) SCREWS.

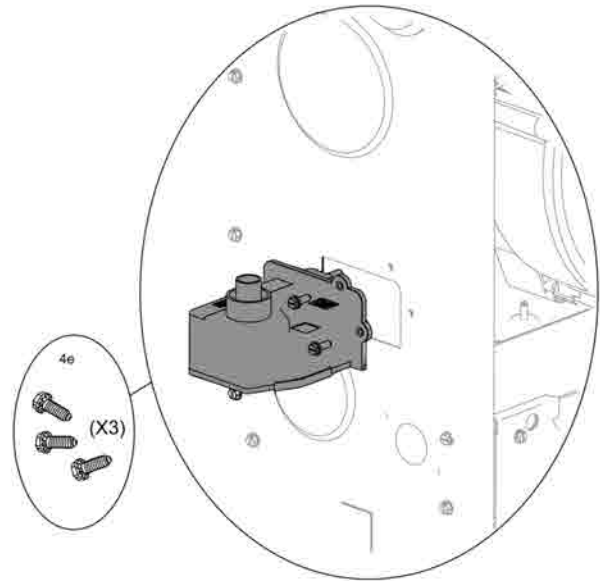
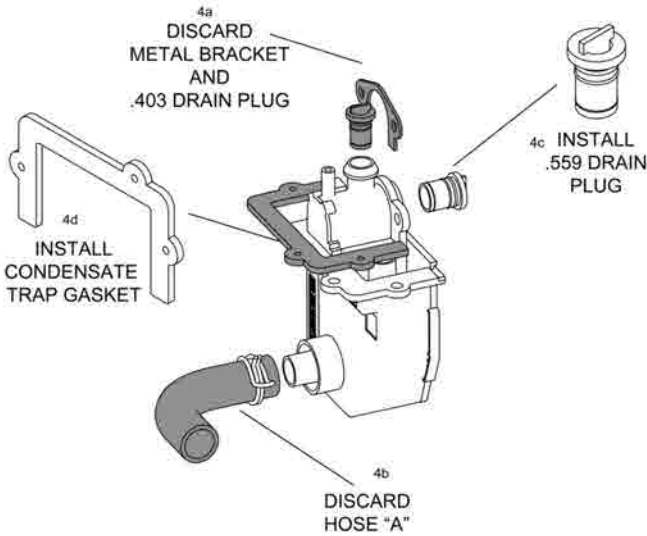

**NOTE:**  
TO PREVENT DAMAGE TO THE TRAP, THE INSTALLER MAY ELECT TO INSTALL IT DURING A LATER STEP. (AFTER THE UNIT IS ROTATED)

**NOTE: REMAINING STEPS SHOWN WITH FURNACE IN HORIZONTAL LEFT ORIENTATION**

Field Conversions

5

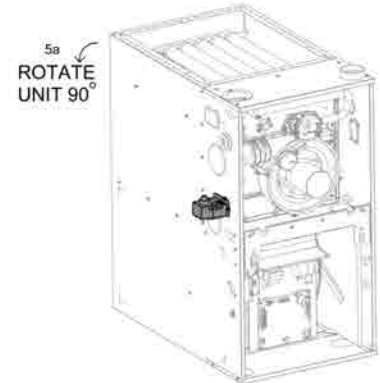
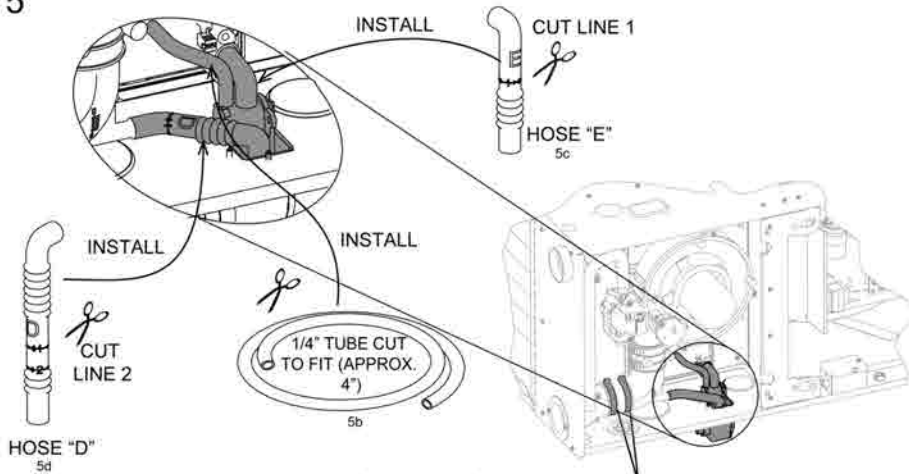

SEE CRITICAL HOSE CLAMP LOCATION NOTE IN THE GENERAL COVERSION INSTRUCTIONS.

**NOTE:**  
USE SOAPY WATER TO FACILITATE EASY HOSE AND TUBE ASSEMBLY

- 5a - ROTATE UNIT 90°
  - 5b - CUT 1/4" VENT HOSE TO FIT (APPROX. 6-1/2") AND INSTALL AS SHOWN.
  - 5c - CUT HOSE E AT LINE 1 - INSTALL
  - 5d - CUT HOSE D (REMOVED IN STEP 1) AT LINE 2 -INSTALL
- NOTE: MAKE SURE CUT IS STRAIGHT AND SQUARE**

ST-A1194-35-X0



## Checklist:

- \_\_\_ VERIFY ALL HOSES ARE SECURE AND FULLY SEATED.
- \_\_\_ CONFIRM THAT ALL HOSES ARE FREE OF KINKS.
- \_\_\_ CONFIRM ALL HOSES AND OTHER DRAIN PARTS HAVE A SLOPE IN DIRECTION OF WATER FLOW.
- \_\_\_ BOTH WORM DRIVES ON THE HOSE CLAMPS OF THE FLUE TRANSITION MUST BE LOCATED ON THE TOP OF THE COUPLING. SEE LOCATION DETAIL IN THE GENERAL CONVERSION INSTRUCTIONS AT THE BEGINNING OF THIS SECTION.
- \_\_\_ ALL CLAMPS AND COUPLINGS ARE TIGHTENED
- \_\_\_ ALL DRAIN PORTS ARE PLUGGED.
- \_\_\_ UNIT HAS FORWARD PITCH.
- \_\_\_ HEAT TAPE INSTALLED(IF REQUIRED)

---

## Notes:

# DUCTING

External filter racks are available from the distributor. Use the following part numbers when ordering:

RXGF-CA	External Side Filter Rack Kit
RXGF-CB	External Bottom Filter Rack Kit
RXGF-CC	External Filter Rack Kit - Downflow

Proper air flow is required for the correct operation of this furnace. Restricted air flow can cause erratic operation and can damage the heat exchanger. The duct system must carry the correct amount of air for heating and cooling if summer air conditioning is used.

## ⚠ WARNING

**SOME HEATING AIRFLOW VALUES MAY BE HIGHER THAN THOSE REQUIRED FOR COOLING. BE SURE TO SIZE DUCT FOR THE MAXIMUM POSSIBLE AIRFLOW VALUE.**

**SIZE AIRFLOW DISTRIBUTION SYSTEM TO ACCEPTABLE INDUSTRY STANDARDS AND METHODS. TOTAL STATIC PRESSURE DROP OF THE AIR DISTRIBUTION SYSTEM SHOULD NOT EXCEED .8 INCHES W.C. THIS WILL INCLUDE ANY AIR CONDITIONER COIL, AIR FILTRATION SYSTEM, ZONING SYSTEM, DUCTWORK, ETC. REFER TO ADDED EQUIPMENT TECHNICAL INFORMATION TO OBTAIN PRESSURE DROP INFORMATION WHEN EQUIPMENT IS OPERATING AT RECOMMENDED HEATING OR COOLING CFMS.**

**IMPORTANT:** When using outside air, design and adjust the system to maintain a return air temperature ABOVE 55° F during the heating season.

**NOTE:** Return air grilles and warm air registers must not be obstructed or closed.

**NOTE:** Both flanges on the supply and return openings must be bent either up or down but cannot remain flat as shipped from the factory. See Figure 9 for details.

## ⚠ WARNING

**THE SOLID METAL BASE PAN MUST BE REMOVED FROM THE TOP OF THE FURNACE BEFORE INSTALLING THE FURNACE. FAILURE TO REMOVE THIS PAN FROM THE SHIPPING POSITION CAN RESULT TO DAMAGE TO THE FURNACE OR EQUIPMENT.**

**FIGURE 7**

**REMOVE SOLID BASE PANEL FROM THE TOP BEFORE INSTALLING FURNACE**

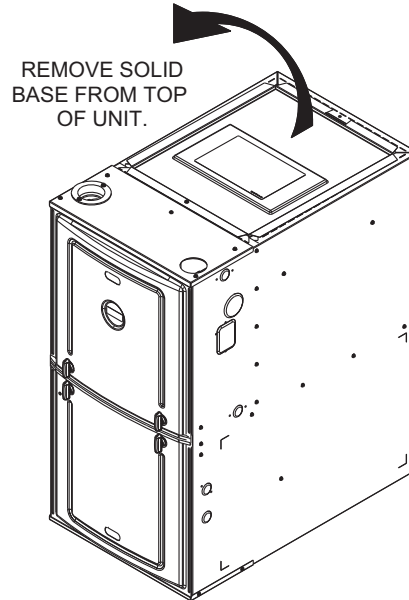

ST-A1194-49

## UPFLOW INSTALLATIONS

1. Position the unit to minimize long runs of duct or runs of duct with many turns and elbows.
2. For side return: Cut an opening in the side. The opening should be cut the full width and height of the knockouts on the unit. See Figure 10.
3. If summer air conditioning is desired, position the indoor coil on the supply-air side of the unit. Ensure that no air can bypass the coil.
4. Connect the furnace to the supply air plenum.
5. Connect the return air ducting to the return-air opening at the bottom and/or side of the unit. Make the connections air-tight to prevent the migration of toxic fumes and odors including carbon monoxide from migrating into the living space.
6. If a filter is installed near the furnace, be sure to have adequate space for installation and removal of the unit filter.
7. **NOTE:** Where the maximum airflow is 1800 CFM or more, BOTH sides or the bottom must be used for the return air.

**NOTE:** DO NOT take return air from furnace rooms, garages or cold areas. Avoid return air from utility rooms, kitchens, laundry rooms and bathrooms.

## ⚠ WARNING

**UPFLOW FURNACE: THE SOLID METAL BASE PLATE (SHIPPED WITH THE FURNACE) MUST BE INSTALLED IN THE FURNACE BOTTOM WHEN USING SIDE AIR RETURN. FAILURE TO INSTALL A BASE PLATE COULD CAUSE THE PRODUCTS OF COMBUSTION TO CIRCULATE INTO THE LIVING SPACE AND CREATE POTENTIALLY HAZARDOUS CONDITIONS, INCLUDING CARBON MONOXIDE POISONING OR DEATH. FOR BOTTOM RETURN, A SOLID METAL BASE PAN MUST NOT BE INSTALLED.**

## DOWNFLOW INSTALLATIONS

1. Position the unit to minimize long runs of duct or runs of duct with many turns and elbows.
2. If summer air conditioning is desired, position the indoor coil on the supply-air side of the unit. Ensure that no air can bypass this coil.
3. If installing on a combustible floor **and not using an air conditioning plenum**, install the special non-combustible floor base. See Table 1 and Figure 11.
4. Connect the furnace to the supply air plenum.
5. Connect the return air ducting to the return air opening at the top of the unit. Make the connection air tight to prevent the migration of toxic fumes and odors including carbon monoxide from migrating into the living space from an adjacent fuel-burning appliance.

FIGURE 8

① REMOVE BLOWER DOOR AS SHOWN

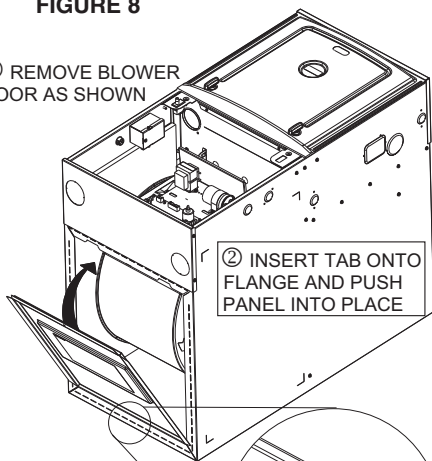

② INSERT TAB ONTO FLANGE AND PUSH PANEL INTO PLACE

RETAINING TAB  
DETAIL

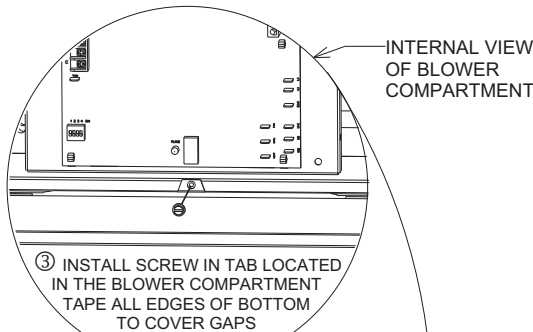
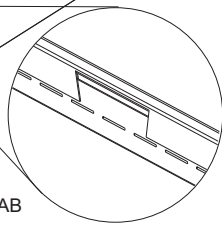

③ INSTALL SCREW IN TAB LOCATED IN THE BLOWER COMPARTMENT TAPE ALL EDGES OF BOTTOM TO COVER GAPS

④ AFTER INSTALLATION OF BOTTOM PLATE, SEAL ALL SEAMS TIGHT WITH METAL TAPE

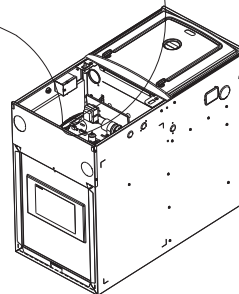

INSTALLATION OF SOLID METAL BASE FOR SIDE RETURN APPLICATIONS

ST-A1194-49

## ⚠ WARNING

**A DOWNFLOW INSTALLATION IS CERTIFIED FOR INSTALLATION ON A NON-COMBUSTIBLE FLOOR. USE THE SPECIAL BASE SPECIFIED ON THE FURNACE CLEARANCE LABEL. FAILURE TO INSTALL THE SPECIAL BASE MAY RESULT IN FIRE, PROPERTY DAMAGE, PERSONAL INJURY OR DEATH. THIS BASE IS AVAILABLE AS AN ACCESSORY.**

**NOTE:** In downflow configuration, side return air cut out is not permitted.

6. If a filter is installed near the furnace, be sure to have adequate space for installation and removal of the unit filter.

**NOTE:** DO NOT take return air from furnace rooms, garages or cold areas. Avoid return air from utility rooms, kitchens, laundry rooms and bathrooms.

# DUCTING

**FIGURE 9**

**FLANGE BENDING INSTRUCTIONS**

AS - SHIPPED FLAT

INSTALLER BENT - UP  
ALTERNATE - BENT (DOWN)

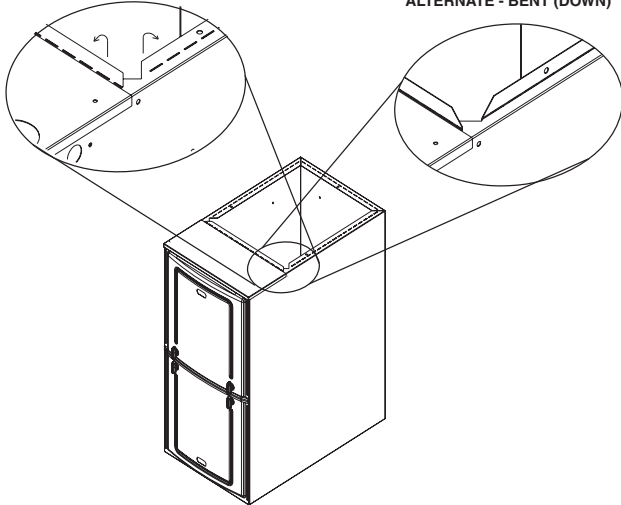

**NOTES:**

THIS VIEW IS REPRESENTATIVE OF BOTH SUPPLY AND RETURN OPENINGS.

DUCT FLANGES MUST BE FIELD - BENT ALONG PERFORATIONS EITHER INTO OR OUT OF THE FURNACE AS NECESSARY FOR INSTALLATIONS BUT **NEITHER FLANGE CAN REMAIN FLAT.**

INSTALLER SHOULD USE DUCK BILLED PLIERS (AKA: FOLDING PLIERS) TO BEND THE FLANGE ALONG THE PERFORATIONS.

ST-A1194-39-00

**FIGURE 10**

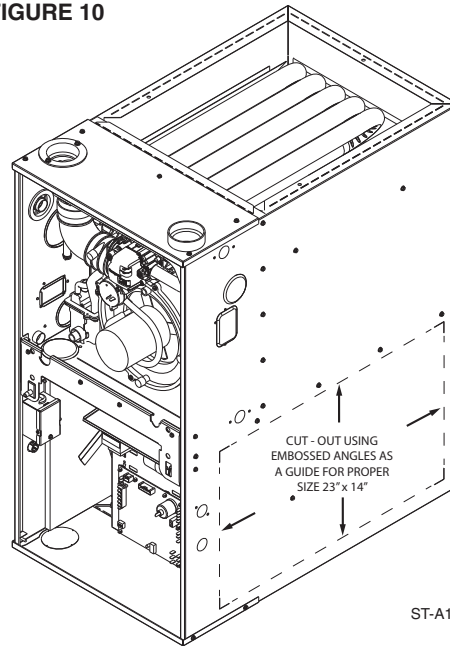

ST-A1194-04-X0

**NOTE:** In horizontal configuration, side return air cut out is not permitted.

- If a filter is installed near the furnace, be sure to have adequate space for installation and removal of the unit filter.**

**NOTE:** DO NOT take return air from furnace rooms, garages or cold areas. Avoid return air from utility rooms, kitchens, laundry rooms and bathrooms.

**TABLE 1**  
**NON-COMBUSTIBLE FLOOR BASES**

Floor Base No.	Size Cabinet
RXGC-B17	17
RXGC-B21	21
RXGC-B24	24

## HORIZONTAL INSTALLATIONS

- Position the unit to minimize long runs of duct or runs of duct with many turns and elbows.
- If summer air conditioning is desired, position the indoor coil on the supply air side of the unit. Ensure that no air can bypass this coil.
- Connect the furnace to the supply air plenum.
- Connect the return air ducting to the return air opening at the return-air end of the unit. Make the connection air tight to prevent the migration of toxic fumes and odors including carbon monoxide from migrating into the living space from an adjacent fuel-burning appliance.

**FIGURE 11**  
**NON-COMBUSTIBLE FLOOR BASE INSTALLATION INSTRUCTIONS**

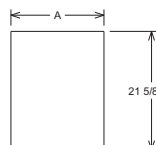
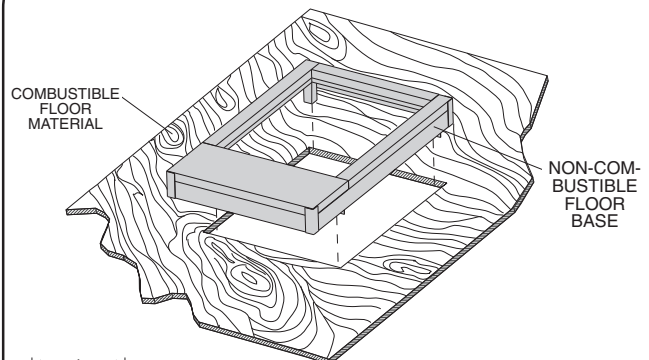

**FLOOR CUTOUT DIMENSIONS**

FLOOR BASE NO.	CABINET WIDTH	FLOOR CUTOUT DIMENSION "A"
RXGC-B17	17.5"	17.0"
RXGC-B21	21.0"	20.0"
RXGC-B24	24.5"	23.5"

ST-A1194-43-00

# GENERAL VENTING REQUIREMENTS AND GUIDELINES

## VENTING & COMBUSTION AIR REQUIREMENTS

### WARNING

**READ AND FOLLOW ALL INSTRUCTIONS IN THIS SECTION. FAILURE TO PROPERLY VENT THIS FURNACE CAN CAUSE CARBON MONOXIDE POISONING, OR AN EXPLOSION OR FIRE, RESULTING IN PROPERTY DAMAGE, PERSONAL INJURY OR DEATH.**

### WARNING

**THIS FURNACE AND ANY OTHER FUEL-BURNING APPLIANCE MUST BE PROVIDED WITH ENOUGH FRESH AIR FOR PROPER COMBUSTION AND VENTILATION OF THE FLUE GASES. MOST BUILDINGS WILL REQUIRE THAT OUTSIDE AIR BE SUPPLIED INTO THE FURNACE AREA. FAILURE TO DO SO CAN CAUSE PERSONAL INJURY OR DEATH FROM CARBON MONOXIDE POISONING. REFER TO SECTION TITLED “NON-DIRECT VENTING” TO DETERMINE IF THE FURNACE MUST USE OUTSIDE AIR FOR COMBUSTION.**

This furnace removes both sensible and latent heat from the combustion gases. Removal of latent heat results in the condensation of flue gas water vapor. This condensed water vapor drains from the secondary heat exchanger and out of the unit into the drain trap.

When installed as a non-direct vent furnace, only exhaust piping is required and inside combustion air may be used. Refer to the section on “NON-DIRECT VENTING.”

Direct vent installations require a dedicated combustion air and venting system. All air for combustion is taken from the outside atmosphere and all combustion products are discharged to the outdoors.

Adequate facilities for providing air for combustion and ventilation must be provided in accordance with Section 5.3, “Air for Combustion and Ventilation” of the National Fuel Gas Code, ANSI Z223.1 (latest edition), in Canada CSA B149.1; Canadian Natural Gas and Propane Installation Code and The National Fire Code of Canada, or applicable provisions for the local building codes, and not obstructed so as to prevent the flow of air to the furnace.

**IMPORTANT:** Air for combustion and ventilation must not come from a corrosive atmosphere. Any failure due to corrosive elements in the atmosphere is excluded from the warranty coverage.

Combustion air must be free of acid-forming chemicals such as sulfur, fluorine and chlorine. These elements are found in aerosol sprays, detergents, bleaches, cleaning solvents, air fresheners, paint and varnish removers, refrigerants and many other commercial and household products. When burned in a gas flame, vapors from these products form acid compounds. The acid compounds increase the dew point temperature of the flue products and are highly corrosive after they condense.

The following types of installations (but not limited to the following) may require outdoor air for combustion (direct vent) due to chemical exposures:

- Commercial buildings
- Buildings with indoor pools
- Furnaces installed in laundry rooms
- Furnaces in hobby or craft rooms
- Furnaces installed near chemical storage areas

If combustion air is exposed to the following substances (but not limited to the following), it should not be used and the furnace may require outdoor air for combustion (direct vent).

- Permanent wave solutions
- Chlorinated waxes and cleaners
- Chlorine-based swimming pool chemicals
- Water softening chemicals
- De-icing salts or chemicals
- Carbon tetrachloride
- Halogen type refrigerants
- Printing inks, paint removers, varnishes etc.
- Cleaning solvents (such as perchloroethylene)
- Hydrochloric acid
- Cements and glues
- Antistatic fabric softeners for clothes dryers
- Masonry curing and acid washing materials

### WARNING

**ALL FURNACE INSTALLATIONS MUST COMPLY WITH THE NATIONAL FUEL GAS CODE, IN CANADA CSA B149.1; CANADIAN NATURAL GAS AND PROPANE INSTALLATION CODE AND THE NATIONAL FIRE CODE OF CANADA, NFPA 54 AND LOCAL CODES TO PROVIDE ADEQUATE COMBUSTION AND VENTILATION AIR FOR THE FURNACE. FAILURE TO DO SO CAN RESULT IN EXPLOSION, FIRE, PROPERTY DAMAGE, CARBON MONOXIDE POISONING, PERSONAL INJURY OR DEATH.**

Combustion air requirements are determined by whether the furnace is in an open (unconfined) area or in a confined space such as a closet or small room.

When the furnace is installed in the same space with other gas appliances, such as a water heater, be sure there is an adequate supply of combustion and ventilation air for the furnace and the other appliances. Do not delete or reduce the combustion air supply required by the other gas appliances in this space. See Z223.1, National Fuel Gas Code (NFPA 54), in Canada CSA B149.1; Canadian Natural Gas and Propane Installation Code and The National Fire Code of Canada, for determining the combustion air requirements for gas appliances. An unconfined space must have at least 50 cubic feet (volume) for each 1,000 BTUH of the total input of all appliances in the space. If the open space containing the appliances is in a building with tight construction (contemporary construction), outside air may still be required for the appliances to burn and vent properly. Outside air openings should be sized the same as for a confined space.

# GENERAL VENTING REQUIREMENTS AND GUIDELINES

## VENTING & COMBUSTION AIR REQUIREMENTS (cont.)

**IMPORTANT: ONLY THE CURRENT VENT INSTRUCTIONS APPLY.** All 90 Plus Gas Furnaces cannot be common-vented.

### OVERTEMPERATURE SAFETY SWITCHES

Furnaces are equipped with safety switches in the burner compartment to protect against over-temperature conditions caused by inadequate combustion air supply. The switches are located in the burner compartment. If a switch is tripped it must be manually reset after clearing the fault condition which caused it to open.

#### WARNING

**DO NOT BYPASS, JUMPER, OR REMOVE ANY SAFETY SWITCH FROM THE FURNACE CONTROL CIRCUIT. IF A SAFETY SWITCH CAUSES THE FURNACE TO SHUT DOWN OR OPERATE INTERMITTENTLY, IT IS AN INDICATION OF A POTENTIAL SAFETY HAZARD THAT MUST BE ADDRESSED BY A QUALIFIED TECHNICIAN, SERVICE AGENCY OR THE GAS SUPPLIER. DO NOT RESET SAFETY CONTROLS WITHOUT CORRECTIVE ACTION AND/OR VERIFICATION OF PROPER SAFE OPERATION BY A QUALIFIED INSTALLER, SERVICE AGENCY OR THE GAS SUPPLIER.**

**REPLACE ANY SAFETY CONTROL COMPONENT ONLY WITH IDENTICAL OEM REPLACEMENT PARTS**

### MATERIAL REQUIREMENTS PIPING REQUIREMENTS

The combustion air and vent pipe fittings must conform to American National Standards Institute (ANSI) and American Society for Testing Materials (ASTM) standards D1785 (Schedule 40 PVC), D2665 (PVC-DWV), D2241 (SDR-21 & SDR26-26 PVC), D2661 (ABS-DWV) or F628 (Schedule 40 ABS-DWV). For Canada PVC, CPVC and polypropylene venting can be used and must conform with ULCS-636C requirements.

**IMPORTANT:** The plastic combustion air and venting components are of Schedule 40 PVC. If using ABS piping, ensure that the solvent cement is compatible for joining PVC to ABS components or use a mechanical connection that can withstand the vent temperatures and is corrosion resistant.

**NOTE:** Schedule 40 ABS-DWV pipe and fittings may be used as an alternate to PVC pipe for the combustion air inlet and vent pipes.

**NOTE:** Cellular core PVC is also approved for use. It must be Schedule 40PVC-DWV cellular pipe for non-pressure applications and manufactured under ASTM-F-891.

All exhaust piping must be installed in compliance with the chapter titled; “*Venting of Appliances*” in the latest

edition of the National Fuel Gas Code, NFPA-54/ANSI Z223.1, CSA B149.1; Canadian Natural Gas and Propane Installation Code (Canada), local codes or ordinances and these instructions.

#### WARNING

**IN CANADA, PRODUCTS CERTIFIED FOR INSTALLATION AND INTENDED TO BE VENTED WITH PLASTIC VENT SYSTEMS (PVC, CPVC & POLYPROPYLENE) MUST USE VENT SYSTEMS THAT ARE CERTIFIED TO THE STANDARD FOR TYPE BH GAS VENTING SYSTEMS, ULC S636.**

**THE COMPONENTS OF THE CERTIFIED MATERIAL MUST NOT BE INTERCHANGED WITH OTHER VENT SYSTEMS OR UNLISTED PIPE/FITTINGS.**

**PLASTIC COMPONENTS AND SPECIFIED PRIMERS AND GLUES OF THE CERTIFIED SYSTEM MUST BE FROM A SINGLE SYSTEM MANUFACTURER AND NOT INTERMIXED WITH OTHER SYSTEM MANUFACTURER'S PARTS.**

**VENT TERMINATIONS ARE NOT REQUIRED TO BE FROM THE SAME MANUFACTURER AS THE REST OF THE VENTING BUT VENT TERMINATIONS MUST BE ULC S636 APPROVED.**

**NOTE: WITH THE EXCEPTION OF THE TERMINATION INLET AIR PIPING IS NOT CONSIDERED TO BE A PART OF THE “VENTING SYSTEM”. THE REQUIREMENT THAT VENT MATERIAL BE CERTIFIED TO ULC S636 DOES NOT APPLY TO INLET AIR PIPING.**

**REGARDLESS, ALL TERMINATIONS ON BOTH INLET AND OUTLET PIPES MUST BE CONSTRUCTED FROM COMPONENTS BUILT TO ULC-S636 REQUIREMENTS.**

1. All horizontal piping must slope upward from the furnace with a minimum slope of ¼ inch per foot of horizontal vent so that condensate drains back toward the furnace.
2. All horizontal runs must be supported at least every 4 feet. No sags or dips are permitted.
3. **IMPORTANT:** Do not common vent with any other appliance. Do not install in the same chase or chimney with a metal or high temperature plastic pipe from another gas or fuel-burning appliance unless the required minimum clearances to combustibles are maintained between the plastic pipe and other pipes. For Canada PVC, CPVC and polypropylene can be used as long as they conform with ULCS-636C requirements.
4. All vent installed through unconditioned spaces where below-freezing temperatures are expected should be insulated with an approved insulating material. Materials such as Armaflex or Rubatex insulation may also be used as long as there is no heat tape applied to the vent pipe. For horizontal runs where water may collect, wrap the vent pipe with self-regulating 3 watt or 6 watt heat tape. The heat tape must be U.L. listed and

# GENERAL VENTING REQUIREMENTS AND GUIDELINES

## VENTING & COMBUSTION AIR REQUIREMENTS (cont.)

installed per the manufacturer's instructions. **NOTE:** Never cover heat tape with insulation.

5. The minimum vent pipe length is 5 feet [1.5m].
6. **IMPORTANT:** No part of the combustion air and/or vent pipes may be installed underground.
7. Piping at a roof, wall or other penetration must be immobilized to prevent pipes from disconnecting. Disconnected pipes may allow flue products to be released inside the structure.
8. For Direct Vent systems, all pipe penetrations through roof or sidewall must be installed so that the vent and combustion air intake pipes terminate in the same atmospheric pressure zone.
9. Vent terminations must be installed with the minimum clearances specified in the TERMINATION REQUIREMENTS sections of this manual and **Figure 21** (for Non-Direct Vent) and **Figure 32** (for direct Vent installations).
10. Piping external to the structure (excluding approved venting terminations) and vent passing through unheated crawl-spaces, attics, verandas, patios or decks must be insulated with approved insulating material to prevent freezing as required for local climate.

### JOINING PIPE AND FITTINGS

#### WARNING

**PVC/CPVC SOLVENT CEMENTS AND PRIMERS ARE HIGHLY FLAMMABLE. PROVIDE ADEQUATE VENTILATION AND DO NOT ASSEMBLE NEAR A HEAT SOURCE OR AN OPEN FLAME. DO NOT SMOKE. AVOID SKIN OR EYE CONTACT. OBSERVE ALL CAUTIONS AND WARNINGS PRINTED ON MATERIAL CONTAINERS. FAILURE TO FOLLOW THESE GUIDELINES MAY RESULT IN FIRE, EXPLOSION OR ASPHYXIATION CAUSING PERSONAL INJURY OR DEATH.**

**TABLE 2: APPLICABLE ASTM STANDARDS FOR VENT MATERIALS** (U.S. Only)

Materials	Sch. 40 Pipe	SDR Pipe	Cell Core Pipe	Fittings	Primer	Solv. Cement
ABS	D1527	-	F628	D2468 & D2661	-	D2235
PVC	D1785	D2241	F891	D2466 & D2665	F656	D2564
CPVC	F441	F442	-	F348	-	F493
ABS to PVC	-	-	-	-	-	D3138

For Canadian installations all exhaust venting materials must be certified to ULCS-636C.

All pipe, fittings, solvent cement, primers and procedures must be installed following the vent manufacturer's installation instructions and must conform to American National Standards Institute and American Society for Testing Materials (ANSI/ASTM) standards as shown in the **Table 2** below:

### CEMENTING JOINTS

Properly seal all joints in the PVC vent using the following materials and procedures.

### PVC CLEANER-PRIMER AND PVC MEDIUM-BODY SOLVENT CEMENT

**IMPORTANT:** After cutting pipe, remove all ragged edges and burrs. This is important to prevent reduction in pressure drop throughout the system.

1. Cut pipe end square. Chamfer edge of pipe. Clean fitting socket and pipe joint area of all dirt, grease and moisture.
2. After checking pipe and socket for proper fit, wipe socket and pipe with cleaner-primer. Apply a liberal coat of primer to inside surface of socket and outside of pipe. Read instructions included with the primer for proper application.
3. Apply a thin coat of cement evenly within the socket. Quickly apply a heavy coat of cement to the pipe end and insert pipe into the fitting with a slight twisting movement until it bottoms out.  
**NOTE:** Cement must be fluid. If not, re-coat.
4. Hold the pipe in the fitting for 30 seconds to prevent the tapered socket from pushing the pipe out of the fitting.
5. Wipe all excess cement from the joint with a rag. Allow 15 minutes before handling. Cure time varies according to fit, temperature and humidity.

**NOTE:** Stir the solvent cement frequently while using. Use a natural bristle brush or the dauber supplied with the can. The proper brush size is one inch.

**IMPORTANT:** For proper installation:

**DO NOT** use solvent cement that has become curdled, lumpy or thickened.

**DO NOT** thin. Observe shelf precautions printed on containers. For applications below 32°F, use only low-temperature type solvent cement.

# GENERAL VENTING REQUIREMENTS AND GUIDELINES

## VENT PIPE SIZING AND MAXIMUM VENT LENGTHS

### EQUIVALENT VENT LENGTHS

The concept of equivalent vent lengths is frequently used in piping systems to account for pressure drop of fittings, such as elbows. The equivalent length of a fitting is the length of a straight section of pipe that has an equivalent pressure drop in the application as the fitting used. With the equivalent length vent concept, a vent system can use up to the maximum number of elbows and vent length of straight pipe as long as the maximum equivalent vent length is not exceeded.

There are several different types of elbows that can be used when constructing a vent system. **Figure 12** shows the standard dimensions for standard and long-sweep 90° (1/4 turn) elbows as specified by ASTM 3311, Standard Specification for Drain, Waste and Vent (DWV) Plastic Fittings Patterns.

**FIGURE 12**  
ELBOWS

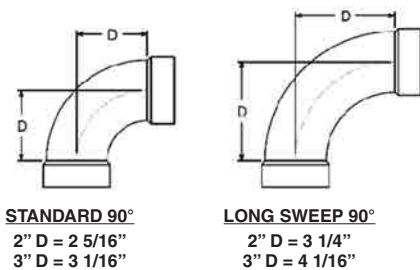

A long-sweep (AKA Long-Radius) 90° (1/4 turn) elbow has an equivalent vent length of 5 feet of straight pipe for either 2 inch or 3 inch plastic pipe. A standard 90° elbow has an equivalent vent length of 10 feet of straight pipe. This equivalent length can be used in circumstances where it might be necessary to lengthen the vent at the outside of the structure, such as in areas with large accumulations of snow in winter. **Table 3** shows the equivalent lengths of different types of elbows.

**TABLE 3: EQUIVALENT VENT LENGTH OF COMMON VENT ELBOWS**

Fitting Type	Equivalent Length
90° Standard Elbow	10 Feet of Pipe
45° Long-Sweep Elbow	2-1/2 Feet of Pipe
90° Long-Sweep Elbow	5 Feet of Pipe

**Table 4** specifies the equivalent maximum vent lengths specified by the manufacturer for each furnace. Listed table maximums have been qualified by the manufacturer. Dependant on individual installation specifics, installations beyond the table recommendations may cause erratic pressure switch operation.

#### Examples:

1. A 60KBTU direct-vent installation needs a 31 foot long vent run with qty=5, 90° long-sweep elbows and 2 inch pipe.

$$\begin{array}{r}
 31 \text{ feet of 2 inch pipe} = 31 \text{ equivalent feet} \\
 \text{Qty} = 5, 90^\circ \text{ long-sweep elbows} = 25 \text{ equivalent feet} \\
 \hline
 \text{Total} = 56 \text{ equivalent feet}
 \end{array}$$

Since the maximum equivalent vent length specified for a 60KBTU furnace is 65 feet, this installation is acceptable.

2. If the installation from Example 1 were installed with standard elbows instead of long-sweep elbows, the calculation would be as follows:

$$\begin{array}{r}
 31 \text{ feet of 2 inch pipe} = 31 \text{ equivalent feet} \\
 \text{Qty} = 5, 90^\circ \text{ standard elbows} = 50 \text{ equivalent feet} \\
 \hline
 \text{Total} = 81 \text{ equivalent feet}
 \end{array}$$

This installation is NOT acceptable as it exceeds the 65 foot maximum specified for this model.

# GENERAL VENTING REQUIREMENTS AND GUIDELINES

## VENT PIPE SIZING AND MAXIMUM VENT LENGTHS (cont.)

<b>TABLE 4: MAXIMUM EQUIVALENT VENT LENGTH (TABLE IS FOR BOTH DIRECT &amp; NON-DIRECT VENTING)</b>				
<b>Model</b>	<b>Input (BTU/H)</b>	<b>Pipe Size</b>	<b>Maximum Equivalent Length (Feet)</b>	<b>Recommended Maximum Number of Elbows*</b>
(-)96VA0602317MSA & (-)96MDV060B30A	56,000	2 inch Ø	65	6
		3 inch Ø	100	6
(-)96VA0702317MSA & (-)96MDV070B30A	70,000	2 inch Ø	65	6
		3 inch Ø	100	6
(-)96VA0852521MSA & (-)96MDV085C50A	84,000	2 inch Ø	30	2
		3 inch Ø	100	6
(-)96VA1002521MSA & (-)96MDV100C50A	98,000	2 inch Ø	20	2**
		3 inch Ø	100	6
<p><b>NOTE:</b> The elbows needed for the vent termination are not counted in these lengths except at altitudes above 6,000 feet. Above 6,000 feet alternate horizontal vent termination elbows are to be included in the equivalent vent length.</p>				
<p>* This is the recommended maximum number of long sweep elbows for either 2 or 3 inch pipe. Combinations of long sweep 90s, standard 90s, or 45s may be used, but the manufacturer recommends the use of long sweep 90s whenever possible because the use of the maximum number of standard 90 and 45 elbows only may result in nuisance furnace outages due to individual installation specifics.</p> <p>Exceeding the recommended maximum number of elbows may cause nuisance operation of the pressure switch.</p>				
<p>** Not applicable for alternate terminations.</p>				

# GENERAL VENTING REQUIREMENTS AND GUIDELINES

## VENT PIPE SIZING AND MAXIMUM VENT LENGTHS (cont.)

### POLYPROPYLENE VENT PRODUCTS

Centrotherm brand *Innoflue* and Duravent *Polypro* Single-wall and flex venting products are approved for use on this furnace product only in single appliance applications. Do not exceed maximum venting lengths, diameters or elbows listed in these instructions (**Vent Pipe Sizing and Maximum Vent Lengths** section [Table 4]). Application of these products is limited to the terminations listed in Ta-

bles 5 and 6 below. These manufacturers have provisions for B-vent liners and chimney liners which can be used with this furnace with non-direct venting applications only. Refer to the manufacturer's installation instructions for proper installation. Contact the manufacturer for all installation and application information.

**NOTE:** These venting products are listed for use in Canada under ULC-S636.

**TABLE 5: DURAVENT BRAND POLYPRO & POLYPRO FLEX TERMINATION COMPONENTS**

2" VENT	3" VENT	Description
2PPS-HTP	3PPS-HTP	Horizontal Direct-Vent Termination
2PPS-HST	3PPS-HST	Horizontal Non-Direct Termination
2PPS-VK, 2PPS-VK-TC	3PPS-VK, 3PPS-VK-TC	Vertical Concentric Kits
2PPS-HK	3PPS-HK	Horizontal Concentric Kits
2PPS-FK	3PPS-FK	Flex Chimney Lining Kit
2PPS-VFT	3PPS-VFT	Vertical Flex Termination Cap
2PPS-BV4, 2PPS-BV5, 2PPS-BV6	3PPS-BV5, 3PPS-BV6	B-VENT Adapter

**TABLE 6: CENTROTHERM BRAND ECO SYSTEMS TERMINATION COMPONENTS**

2" VENT	3" VENT	Description	Notes
ISCP02	ISCP03	Chimney Cover	For Use on Non-Direct Vent only. <b>DO NOT</b> use with a Direct-Vent Installation.
NA	ISCM03	Stainless Steel Chimney Cover	For Use on Non-Direct Vent only. <b>DO NOT</b> use with a Direct-Vent Installation.
IABC0204 thru IABC0207	IABC0304 thru IABC0307	B-Vent Rain Collar	For Use on on Non-Direct Vent only. <b>DO NOT</b> use with a Direct-Vent Installation.
ISLPT0202	ISLPT0303	Low-Profile Wall Termination	
ISTT0220	ISTT0320	Termination Tee	
ISEP02 & ISEP0239	ISEP03 & ISEP0339	End Pipe	
IFEPO2	NA	2" Flex End Pipe	
NA	ICWT352	Plastic Concentric Wall Termination	Approved for Direct-Vent
ICW2413	ICW3513	Stainless Steel Concentric Wall Termination	Approved for Direct-Vent
ICRT2439	ICRT3539	Concentric Roof (Vertical) Termination	Approved for Direct-Vent

# GENERAL VENTING REQUIREMENTS AND GUIDELINES

## TERMINATION REQUIREMENTS

### CAUTION

THE COMBUSTION PRODUCTS AND MOISTURE IN THE FLUE GASES WILL CONDENSE AS THEY LEAVE THE TERMINATION. THE CONDENSATE CAN FREEZE ON THE EXTERIOR WALL, UNDER THE EAVES AND ON SURROUNDING OBJECTS. SOME DISCOLORATION TO THE EXTERIOR OF THE BUILDING IS TO BE EXPECTED. HOWEVER, IMPROPER LOCATION OR INSTALLATION CAN RESULT IN FINISH DAMAGE TO THE BUILDING AND MAY RE-CIRCULATE THE PRODUCTS OF COMBUSTION INTO THE COMBUSTION AIR TERMINAL AND FREEZE.

Vent terminations for both Non-Direct and Direct-Vent installations must adhere to guidelines specified by the latest edition of ANSI Z21.47 **Gas-Fired Central Furnaces**. These are clearly detailed in **Figure 21** for Non-Direct-Vent installations and **Figure 32** for Direct-Vent installations. In addition to these requirements, the installation and venting must also comply with the National Fuel Gas Code (U.S.) and CSA-B149.1; Canadian Natural Gas and Propane Installation Code (Canada) and the following requirements must also be met:

**NOTE:** Screens of any kind on the inlet or exhaust pipes are not permitted and will void the manufacturer's warranty.

In addition to the requirements shown in **Figure 21** for Non-Direct venting and **Figure 32** for Direct-Venting, the vent must be installed with the following minimum clearances:

1. The vent terminal shall have a minimum horizontal clearance of 4 feet from electric meters, gas meters, regulators and relief equipment.
  2. Locate the furnace combustion air inlet a minimum of 3 feet from the vent of any other gas or fuel-burning appliance or clothes dryer to prevent recirculation of the flue gases into the furnace combustion air inlet. The only exception to this requirement is the case of multi-venting two or more furnaces, which is covered in the section on multiventing of these instructions.
- In addition to the minimum clearances listed above and in **Figure 21** (Non-Direct Vent) and **Figure 32** (Direct-Vent), the vent location should also be governed by the following guidelines.
1. Avoid terminating under any kind of patio or deck. However, if necessary, vent piping may be installed under a deck as long as the termination(s) is (are) not under the deck.
  2. If installing the vent under a deck, insulate it to insure that no condensate freezes and blocks the pipes.
  3. Do not terminate in any area or behind any obstruction that may allow the flue products to become stagnant and/or re-circulate.
  4. Do not locate on the side of a building with prevailing winter winds. This will help prevent moisture from freezing on the walls and overhangs (under eaves).
  5. If extending vent through a brick or masonry surface, a sleeve between the wall and venting is suggested to protect against damage from thermal expansion and contraction.
  6. A corrosion-resistant sheet metal or plastic backing plate installed on the wall behind the vent is suggested to prevent exhaust gases and condensate from contacting the wall.
  7. Avoid locating too close to shrubs as condensate may stunt growth or kill them.

# GENERAL VENTING REQUIREMENTS AND GUIDELINES

## NON-DIRECT VENT

### ⚠ WARNING

ALL FURNACE INSTALLATIONS MUST COMPLY WITH THE NATIONAL FUEL GAS CODE, NFPA 54, AND IN CANADA CSA B149.1; CANADIAN NATURAL GAS AND PROPANE INSTALLATION CODE, THE NATIONAL FIRE CODE OF CANADA, AND LOCAL CODES TO PROVIDE ADEQUATE COMBUSTION AND VENTILATION AIR FOR THE FURNACE. FAILURE TO DO SO CAN RESULT IN EXPLOSION, FIRE, PROPERTY DAMAGE, CARBON MONOXIDE POISONING, PERSONAL INJURY OR DEATH.

For improved indoor air quality, added safety and product performance we recommend direct vent type installations. If non-direct vent type vent system is used, the requirements for combustion air must be provided as identified in the National Fuel Gas Code and, in Canada, CSA B149.1; Canadian Natural Gas and Propane Installation Code.

Combustion air requirements are determined by whether the furnace is in an open (unconfined) area or in a confined space such as a closet or small room.

### ⚠ WARNING

READ AND FOLLOW THE *GENERAL VENTING REQUIREMENTS AND GUIDELINES* OF THIS MANUAL FOR ADDITIONAL VENTING REQUIREMENTS PERTAINING TO ALL FURNACE INSTALLATIONS (INCLUDING DIRECT AND NON-DIRECT VENTING). FAILURE TO FOLLOW ALL INSTRUCTIONS IN THIS MANUAL CAN RESULT IN EQUIPMENT FAILURE, EQUIPMENT DAMAGE, PROPERTY DAMAGE, PERSONAL INJURY OR DEATH.

## CONFINED AND UNCONFINED SPACES

The below instructions are for U.S. installations only. The terms **Confined Space** and **Unconfined Space** refer to U.S. installations only. In Canada the proper term to use is **Enclosure** when specifying that a furnace is installed in a partially enclosed or fully enclosed room or space. For Canadian installations, to determine combustion air requirements for non-direct vent installations, the installer must follow CSA B149.1; Canadian Natural Gas and Propane Installation Code and NOT the below instructions.

**TABLE 7: MINIMUM SPACE REQUIREMENTS FOR UNCONFINED SPACE, NON-DIRECT VENT**

Input (BTUH)	Minimum Space (Cubic Ft)	Minimum Area with 8ft Ceilings (sq ft)	Typical Room Size w/ 8' Ceilings (ft x ft)
42,000	2,100	263	14 x 20
56,000	2,800	350	18 x 20
70,000	3,500	438	22 x 20
84,000	4,200	525	25 x 20
98,000	4,900	613	20 x 30
112,000	5,600	700	25 x 30

## FURNACE LOCATED IN AN UNCONFINED SPACE (U.S. INSTALLATIONS) USING INDOOR AIR FOR COMBUSTION:

An unconfined space must have at least 50 cubic feet for each 1,000 BTUH of total input for all appliances in the space. **Table 7** below specifies minimum space requirements and a few examples of the room sizes required for different inputs. The sizes are based on 8-foot ceilings.

If the open space containing the furnace is in a building with tight construction, outside air may still be required for the furnace to operate and vent properly. Outside air openings should be sized the same as for a confined space.

## FURNACE LOCATED IN A CONFINED SPACE (U.S. INSTALLATIONS)

A confined space is defined as any space for a given furnace input rating which is smaller than that which is specified in **Table 7** as minimum for an "unconfined" space. If the space is less than that specified in this table, the space is defined as "confined".

If the space is small enough to be designated as "confined", it must have openings into the space which are located in accordance with the requirements set forth in the following subsections A and B. Size connected to the heated area or to the outside, and by the input of **ALL** appliances in the space.

If the confined space is within a building with tight construction, combustion air must be taken from outdoors or from an area freely communicating with the outdoors.

### A. USING INDOOR AIR FOR COMBUSTION:

**IMPORTANT:** Air should not be taken from a heated space with a fireplace, exhaust fan or other device that may produce negative pressure.

If combustion air is taken from the heated area, the openings must each have at least 100 square inches of free area. Each opening must have at least one square inch of free area for each 1,000 BTUH of total input in the space. **Table 8** shows some typical examples of openings required for combustion air openings required for a confined space.

**TABLE 8: MINIMUM FREE AREA OPENING REQUIRED FOR A FURNACE LOCATED IN A CONFINED SPACE USING INDOOR AIR FOR COMBUSTION.**

Input (BTUH)	Free Area for Each Opening (sq inches)
42,000	100
56,000	100
70,000	100
84,000	100
98,000	100
112,000	120

# GENERAL VENTING REQUIREMENTS AND GUIDELINES

## NON-DIRECT VENT (cont.)

### B. USING OUTDOOR AIR FOR COMBUSTION:

**IMPORTANT:** Do not take air from an attic space that is equipped with power ventilation.

The confined space must communicate with the outdoors in accordance with Methods 1 or 2 below. The minimum dimension of air openings shall not be less than 3 inches. Where ducts are used, they shall be of the same cross-sectional area as the free area of the openings to which they connect.

**METHOD 1:**

Two permanent openings, one located within 12 inches of the top and one located within 12 inches of the bottom of the enclosure, shall be provided. The openings shall communicate directly, or by ducts, with the outdoors or spaces (crawl or attic) that freely communicate with the outdoors.

**TABLE 9: MINIMUM FREE AREA REQUIRED FOR EACH OPENING (WHEN TWO OPENINGS ARE USED) WITH A FURNACE:**

1. LOCATED IN A CONFINED SPACE
2. USING OUTDOOR AIR FOR COMBUSTION
3. COMMUNICATING DIRECTLY TO THE OUTSIDE THROUGH AN OPENING OR THROUGH A VERTICAL DUCT.

Total Input for ALL Gas Appliances (BTUH)	Free Area for Each Opening when 2 Separate Openings are used (sq inches)	Round Pipe Duct Diameter (Vertical Duct Only) (inches)
42,000	10	4
56,000	15	5
70,000	20	5
84,000	25	5
98,000	25	5
112,000	30	6

**TABLE 10: MINIMUM FREE AREA REQUIRED FOR EACH OPENING (WHEN TWO OPENINGS ARE USED) WITH A FURNACE:**

1. LOCATED IN A CONFINED SPACE
2. USING OUTDOOR AIR FOR COMBUSTION
3. COMMUNICATING DIRECTLY TO THE OUTSIDE THROUGH A HORIZONTAL DUCT.

Total Input for ALL Gas Appliances (BTUH)	Free Area for Each Opening when 2 Separate Openings are used (sq inches)	Round Pipe Duct Diameter (Horizontal Duct Only) (inches)
42,000	21	6
56,000	28	6
70,000	35	7
84,000	42	8
98,000	49	8
112,000	56	9

A. Where directly communicating with the outdoors through an opening or where communicating to the outdoors through vertical ducts as shown in **Figure 14**, each opening shall have a minimum free area of 1 square inch for each 4,000 BTUH of total appliance input rating of all equipment in the enclosure. **Table 9** below specifies the minimum area for each of the 2 combustion air openings and minimum round duct diameter for direct openings and vertical ducting only.

B. Where communicating with the outdoors through horizontal ducts, each opening shall have a minimum free area of 1 square inch for each 2,000 BTUH of total appliance input rating of all equipment in the enclosure (see **Figure 15**). **Table 10** specifies the minimum area for each of the 2 combustion air openings and minimum round duct diameter for horizontal ducting only.

**METHOD 2:**

One permanent opening located within 12 inches of the top

**TABLE 11: MINIMUM FREE AREA REQUIRED FOR AN OPENING (WHEN ONE OPENING IS USED) WITH A FURNACE:**

1. LOCATED IN A CONFINED SPACE
2. USING OUTDOOR AIR FOR COMBUSTION
3. COMMUNICATING DIRECTLY TO THE OUTSIDE.

Total Input for ALL Gas Appliances (BTUH)	Free Area for an Opening when 1 Opening is used (sq inches)	Round Pipe Duct Diameter (inches)
42,000	21	6
56,000	28	6
70,000	35	7
84,000	42	8
98,000	49	8
112,000	56	9

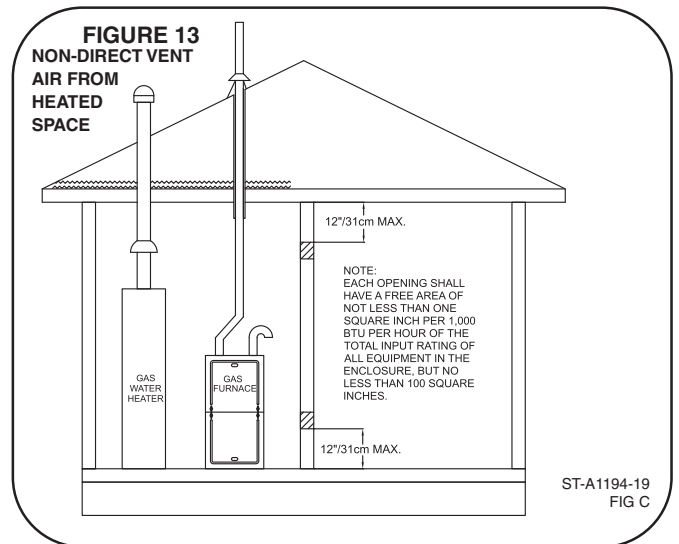

# GENERAL VENTING REQUIREMENTS AND GUIDELINES

## NON-DIRECT VENT (cont.)

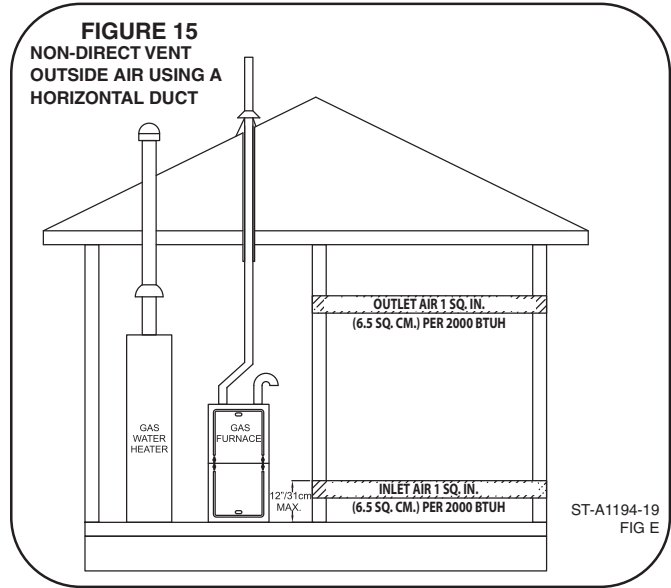
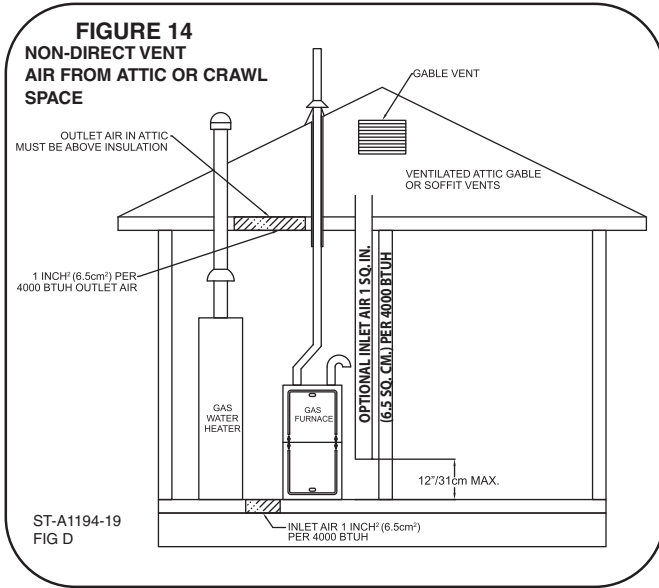

of the enclosure, shall be permitted where the equipment has clearances of at least 1 inch from the sides and back and 6 inches from the front of the appliance. The opening shall directly communicate with the outdoors or communicate through a vertical or horizontal duct to the outdoors or

spaces (crawl or attic) that freely communicate with the outdoors, and shall have a minimum of:

- A. 1 Square inch for each 3,000 BTUH of the total input rating of all equipment located in the enclosure and

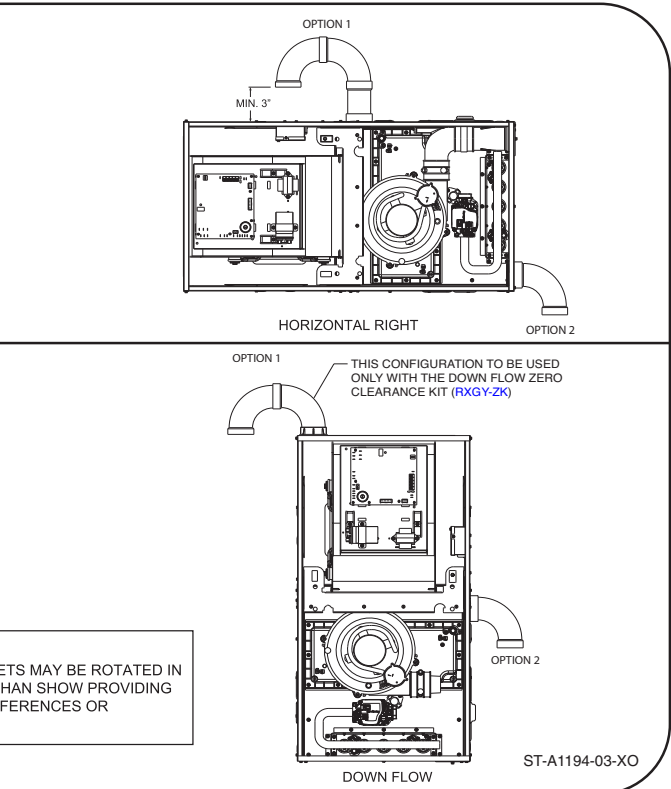
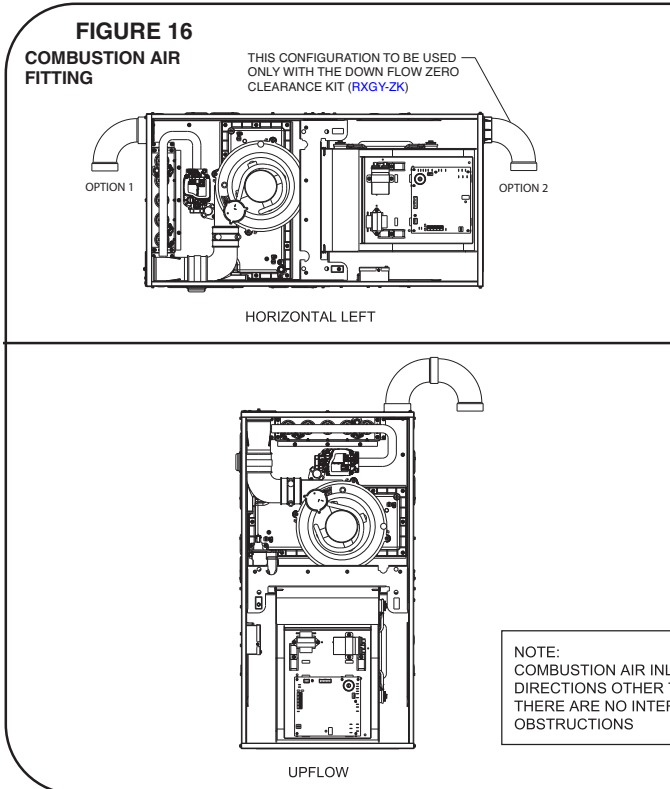

NOTE:  
COMBUSTION AIR INLETS MAY BE ROTATED IN DIRECTIONS OTHER THAN SHOW PROVIDING THERE ARE NO INTERFERENCES OR OBSTRUCTIONS

# GENERAL VENTING REQUIREMENTS AND GUIDELINES

## NON-DIRECT VENT (cont.)

- B. Not less than the sum of the areas of all vent connectors in the confined space.

If the unit is installed where there is an exhaust fan, sufficient ventilation must be provided to prevent the exhaust fan from creating negative pressure.

Combustion air openings must not be restricted in any manner.

**Figure 16** shows allowable inlet air configurations for furnaces installed with non-direct vent.

**IMPORTANT:** When indoor combustion air is used, the inlet air opening at the furnace must be protected from accidental blockage (see **Figure 16**).

### WARNING

**DO NOT USE VENT TERMINATIONS WHICH ARE NOT SPECIFIED IN THESE INSTRUCTIONS. USING VENT TERMINATIONS OTHER THAN THOSE SPECIFIED HERE CAN RESULT IN ERRATIC OPERATION, EQUIPMENT FAILURE OR PERSONAL INJURY OR DEATH FROM CARBON MONOXIDE POISONING.**

## NON-DIRECT VENTING TERMINATIONS

These furnaces are design-certified to use a single vent pipe where all combustion air is taken from indoors and can be vented either vertically or horizontally.

### CAUTION

**ALL VENTS INSTALLED THROUGH UNCONDITIONED SPACE WHERE BELOW-FREEZING TEMPERATURES ARE EXPECTED SHOULD BE INSULATED WITH APPROVED INSULATION MATERIAL. MATERIAL SUCH AS ARMAFLEX OR RUBATEX INSULATION MAY ALSO BE USED AS LONG AS THERE IS NO HEAT TAPE IS APPLIED TO THE VENT PIPE. FAILURE TO INSULATE THE PIPE COULD RESULT IN FREEZING OF WATER IN THE PIPE THEREBY BLOCKING THE PIPE AND PREVENTING FURNACE OPERATION.**

### OPTION 1: VERTICAL TERMINATION

**Figure 17** shows a standard non-direct vertical vent termination with clearances.

### OPTION 2: STANDARD HORIZONTAL TERMINATION

**Figure 18** shows the standard non-direct vent horizontal termination with minimum clearances.

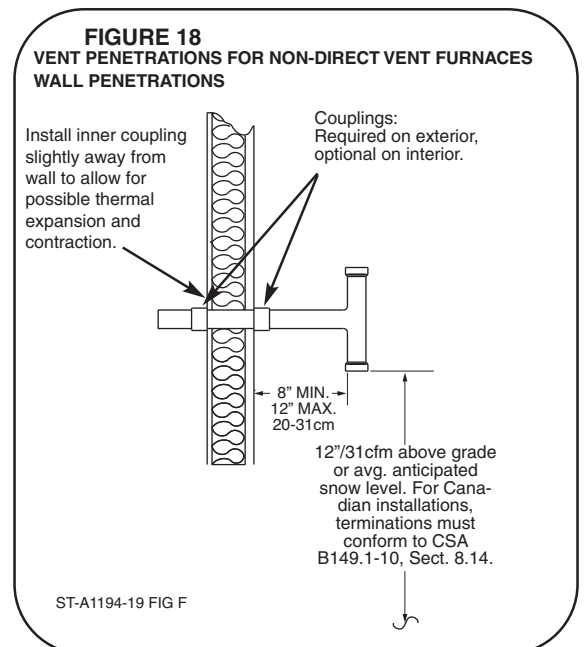
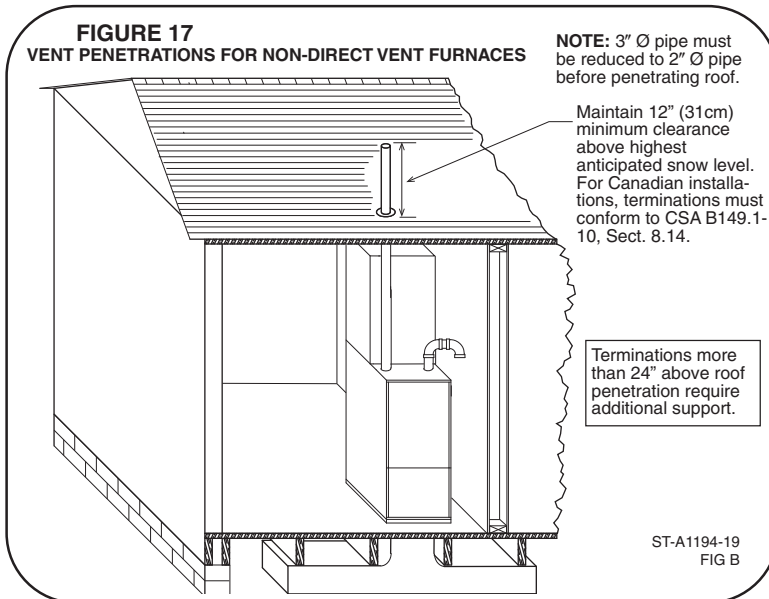

# GENERAL VENTING REQUIREMENTS AND GUIDELINES

## NON-DIRECT VENT (cont.)

### OPTION 3: ALTERNATE HORIZONTAL TERMINATION

Figure 19 shows the alternate non-direct vent horizontal termination with minimum clearances.

Venting

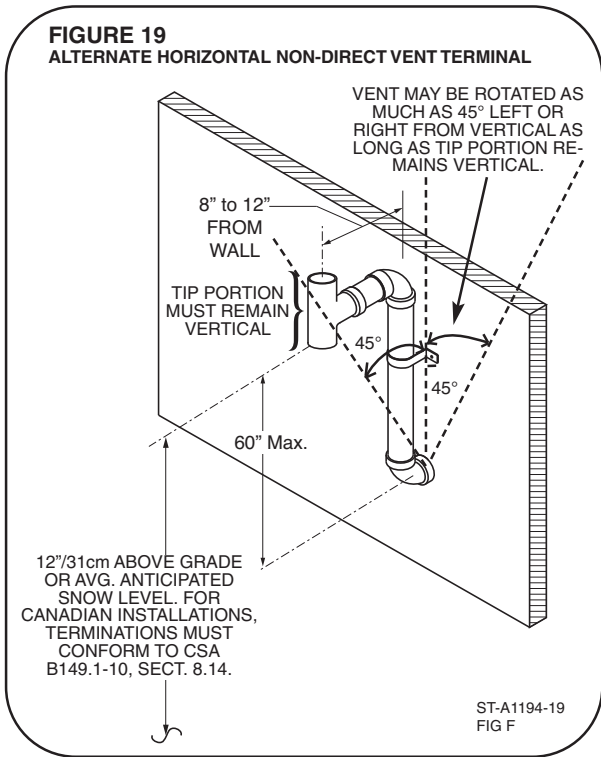

### OPTION 4: RXGY-G02 SIDE WALL VENT TERMINATION

See **Figure 20** and refer to the **DIRECT VENT** Section, **OPTION 8: SIDEWALL VENT KIT** of this manual for information and directions on the side wall vent kit. The sidewall vent kit (RXGY-G02) can be used for both direct-vent and non-direct vent installations.

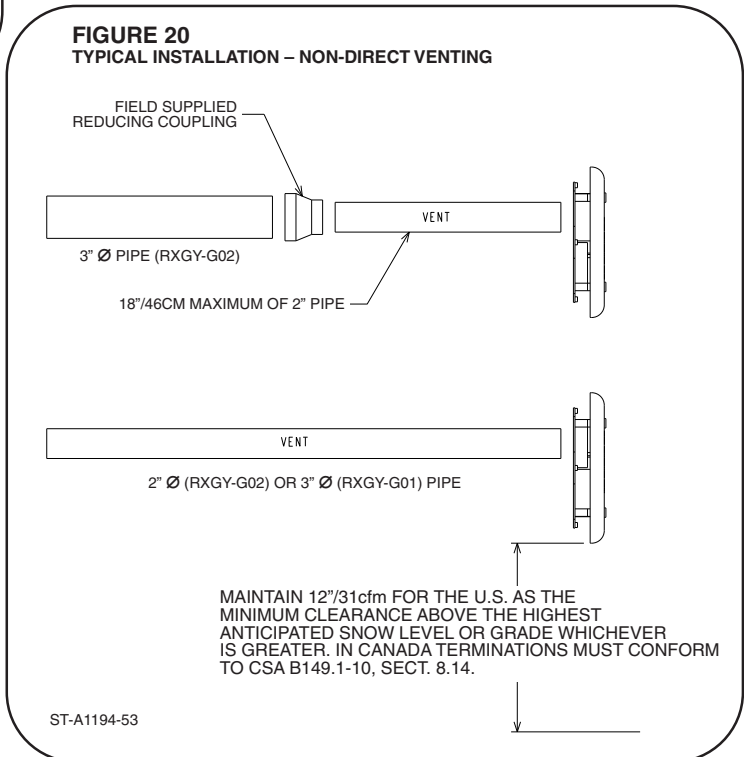

# GENERAL VENTING REQUIREMENTS AND GUIDELINES

## NON-DIRECT VENT TERMINATION CLEARANCES

Figure 21 shows minimum clearances that must be used for non-direct venting terminations.

**FIGURE 21**  
VENT TERMINATION CLEARANCES FOR NON-DIRECT VENT INSTALLATIONS

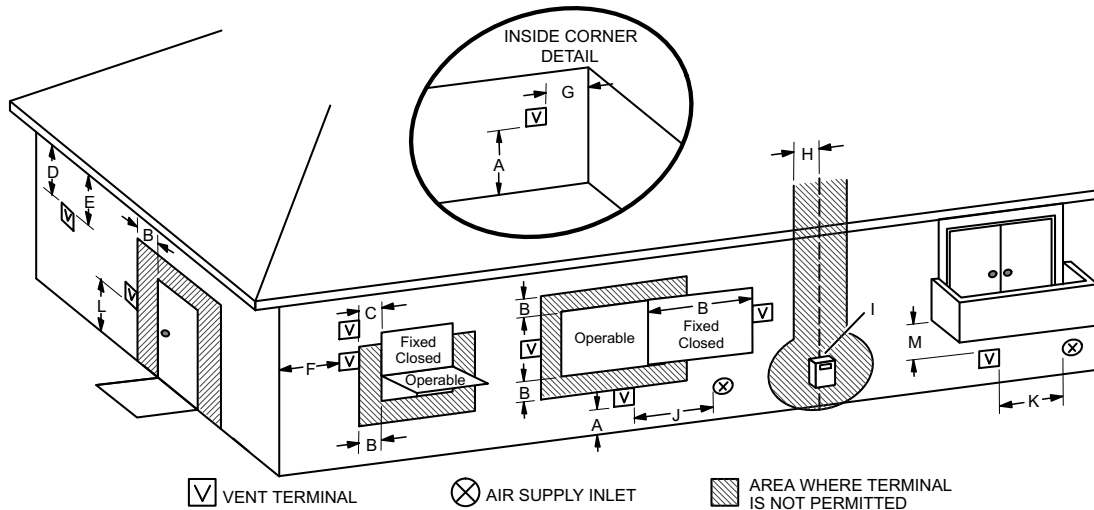

	US Installations <sup>1</sup>	Canadian Installations <sup>2</sup>
A = Clearance above grade, veranda, porch, deck or balcony	12 inches (305mm) or 12 in. 305mm) above average snow accumulation.	must conform to CSA B149.1-10, Sect. 8.14.
B = Clearance to window or door that may be opened	4 feet (1.2m) below or to side of opening; 1 foot (30cm) above opening	6 inches (15cm) for appliances <10,000 Btuh (3kw), 12 inches (30cm) for appliances >10,000 Btuh (3kw), and <100,000 Btuh (30kw), 36 inches (.9m) for appliances > 100,000 Btuh (30kw)
C = Clearance to permanently closed window	* 12" (30cm)	* 12" (30cm)
D = Vertical clearance to ventilated soffit located above the terminal within a horizontal distance of 2 feet (0.6m) from the center line of the terminal	* Equal to or greater than soffit depth	* 3" (0.9m)
E = Clearance to unventilated soffit	* Equal to or greater than soffit depth	* 2" (0.6m)
F = Clearance to outside corner	* No minimum to outside corner	* No minimum to outside corner
G = Clearance to inside corner	* 3 ft. (.9m), 10 ft. (3.05 m) preferred	* 3 ft. (.9m), 10 ft. (3.05 m) preferred
H = Clearance to each side of center line extended above meter / regulator assembly	3 feet (.9m) within a height 15 feet (4.5m) above the meter / regulator assembly	3 feet (.9m) within a height 15 feet (4.5m) above the meter / regulator assembly
I = Clearance to service regulator vent outlet	3 feet (.9m)*	*3 feet (.9m)
J = Clearance to non-mechanical air supply inlet to building or the combustion air inlet to any other appliance	4 feet (1.2m) below or to side of opening; 1 foot (30cm) above opening	6 inches (15cm) for appliances <10,000Btuh (3kw), 12 inches (30cm) for appliances > 10,000 Btuh (3kw) and <100,000 Btuh (30kw), 36 inches (.9m) for appliances > 100,000 Btuh (30kw)
K = Clearance to mechanical air supply inlet	3 feet (.9m) above if within 10 feet (3m) horizontally	6 feet (1.8m)
L = Clearance above paved sidewalk or paved driveway located on public property	* 7 feet (2.1m)	7 feet (2.1m)†
M = Clearance under veranda, porch, deck or balcony	*12 inches (305mm)‡	12 inches (30cm) ‡

<sup>1</sup> In accordance with the current ANSI Z223.1/NFPA 54 Natural Fuel Gas Code

<sup>2</sup> In accordance with the current CSA B149.1, Natural Gas and Propane Installation Code

† A vent shall not terminate less than 7 ft. (2.1m) above a paved sidewalk or paved driveway that is located on public property.

‡ Permitted only if veranda, porch, deck or balcony is full open on a minimum of two sides beneath the floor. We recommend avoiding this location if possible.

\*For clearances not specified in ANSI Z223.1/NFPA 54 or CSA B149.1, clearance will be in accordance with local installation codes and the requirements of the gas supplier and these installation instructions."

ST-A1194-19 FIG A

# GENERAL VENTING REQUIREMENTS AND GUIDELINES

## DIRECT VENT

### ⚠ WARNING

ALL FURNACE INSTALLATIONS MUST COMPLY WITH THE NATIONAL FUEL GAS CODE OR, IN CANADA, CSA B149.1; NATURAL GAS AND PROPANE INSTALLATION CODE AND LOCAL CODES TO PROVIDE ADEQUATE COMBUSTION AND VENTILATION AIR FOR THE FURNACE. FAILURE TO DO SO CAN RESULT IN EXPLOSION, FIRE, PROPERTY DAMAGE, CARBON MONOXIDE POISONING, PERSONAL INJURY OR DEATH.

### ⚠ WARNING

READ AND FOLLOW THE *GENERAL VENTING REQUIREMENTS AND GUIDELINES* OF THIS MANUAL FOR ADDITIONAL VENTING REQUIREMENTS PERTAINING TO ALL FURNACE INSTALLATIONS (INCLUDING DIRECT AND NON-DIRECT VENTING). FAILURE TO FOLLOW ALL INSTRUCTIONS IN THIS MANUAL CAN RESULT IN EQUIPMENT FAILURE, EQUIPMENT DAMAGE, PROPERTY DAMAGE, PERSONAL INJURY OR DEATH.

### DIRECT-VENT (2-PIPE) INSTALLATIONS

The field-supplied vent system used for direct-vent installations uses 2 pipes; one inlet pipe for supplying the combustion air to the furnace, and an exhaust (or flue) pipe for transferring the flue products to the outside. The flue pipe is elevated at least 12 inches above the air intake pipe for all vertical installations to prevent flue gas recirculation during operation.

The furnace combustion air inlet must be located a minimum of 3 feet from the vent of any other gas or fuel-burning appliance or clothes dryer to prevent recirculation of the flue gases into the furnace combustion air inlet. The only exception to this requirement is the case of multiventing two or more furnaces, which is covered in the section on multiventing of these instructions.

Direct-Vent systems must be installed so that the vent and combustion air intake pipes terminate in the same atmospheric pressure zone.

### OPTION 1: STANDARD VERTICAL DIRECT-VENT TERMINATION

*Figure 22* below shows a standard vertical termination for direct venting installations. Maintain the dimensions specified in this drawing for vertical venting of direct-vent furnace installations. Specific details of the roof penetration can be found in *Figure 23*.

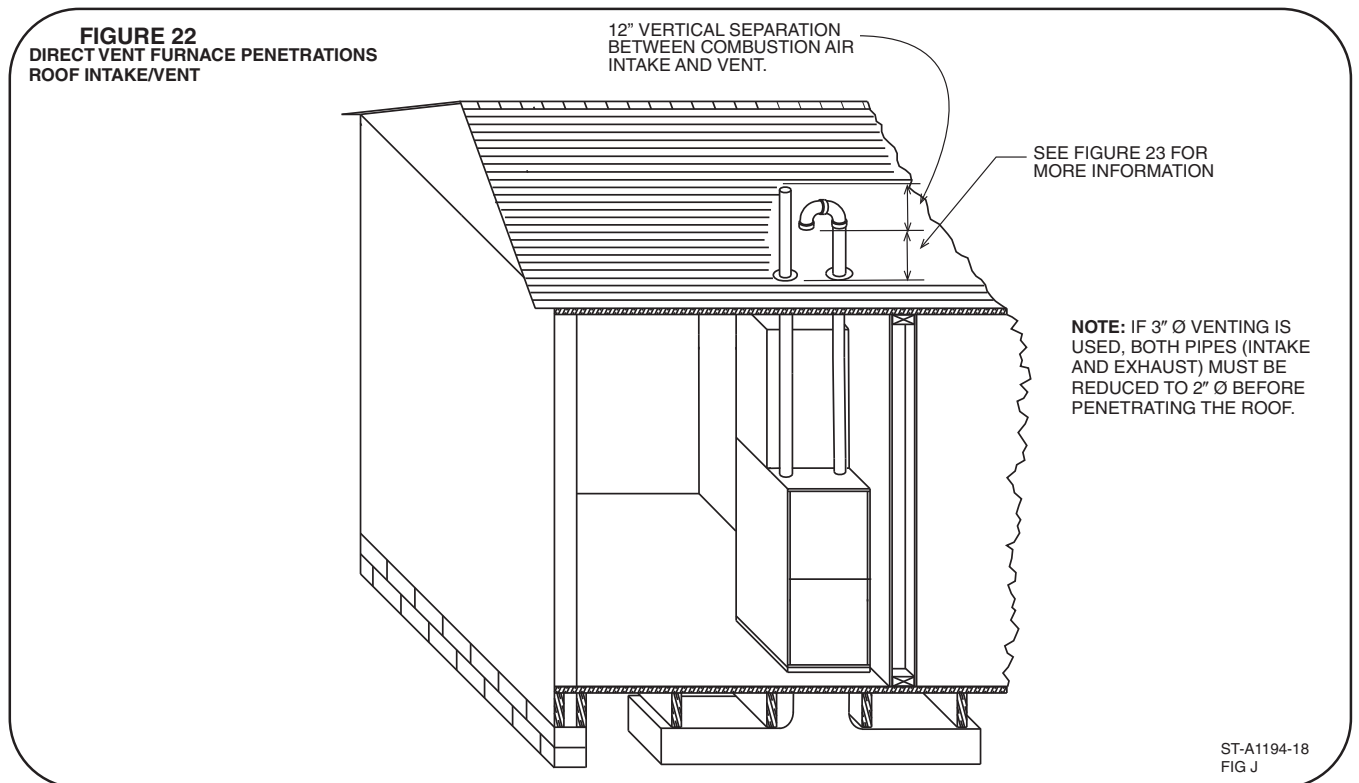

# GENERAL VENTING REQUIREMENTS AND GUIDELINES

## DIRECT VENT (cont.)

Figure 23 below shows the necessary detail for the roof penetration on a standard direct-vent vertical termination.

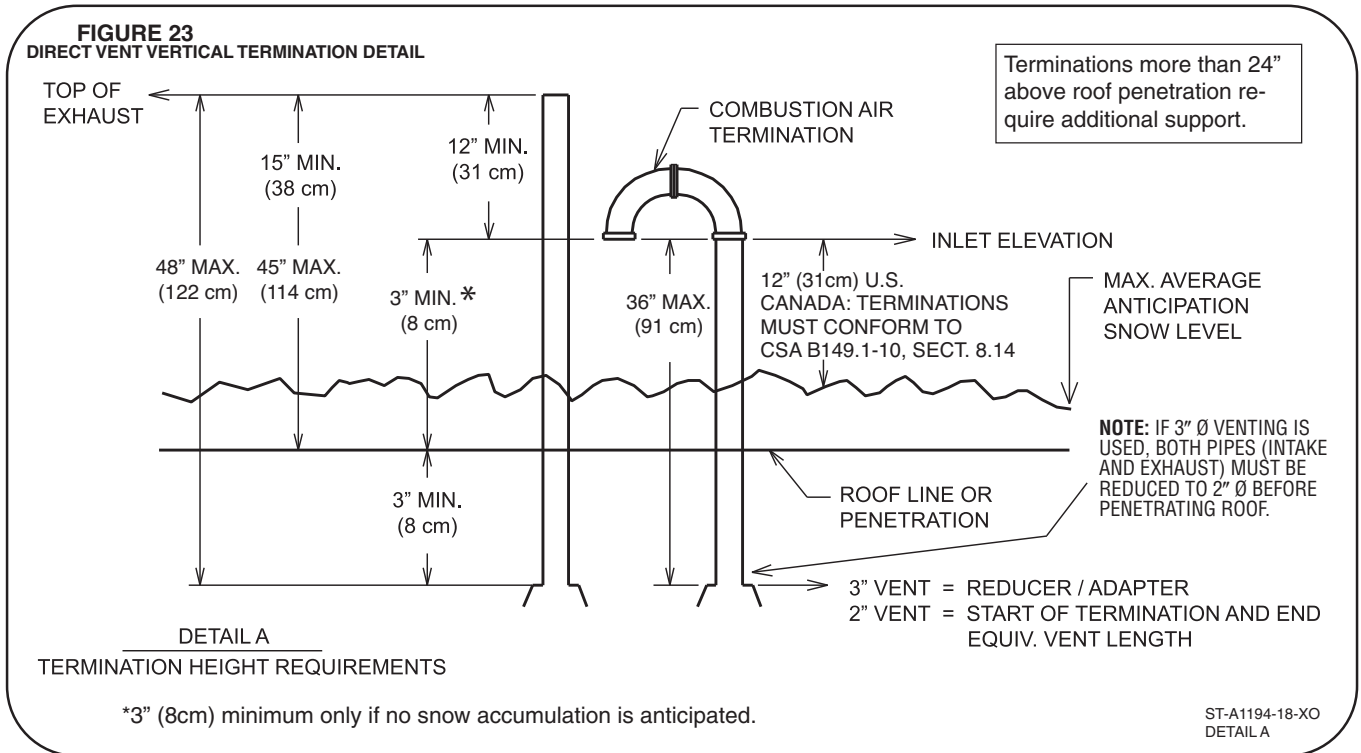

# GENERAL VENTING REQUIREMENTS AND GUIDELINES

## DIRECT VENT (cont.)

### OPTION 2: STANDARD HORIZONTAL DIRECT-VENT TERMINATION

**FIGURE 24**  
STANDARD HORIZONTAL DIRECT VENTING

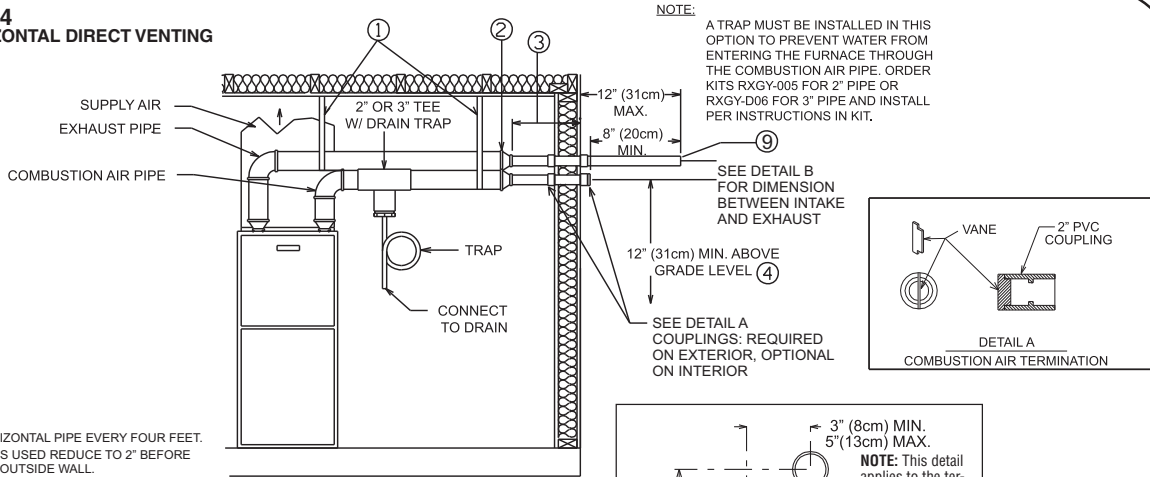

- NOTES:**
- 1) SUPPORT HORIZONTAL PIPE EVERY FOUR FEET.
  - 2) WHEN 3" PIPE IS USED REDUCE TO 2" BEFORE PENETRATING OUTSIDE WALL.
  - 3) WHEN USING 3" Ø VENT AND NECKING DOWN TO 2" Ø AS REQUIRED, 18" (46cm) MAX. 2" DIA. PIPE MAY BE USED INSIDE THE WALL.
  - 4) INCREASE THE 12" (31cm) MIN. (U.S.) ABOVE GRADE TO KEEP TERMINAL OPENINGS ABOVE ANTICIPATED LEVEL OF SNOW ACCUMULATION WHERE APPLICABLE. CANADA: TERMINATIONS MUST CONFORM TO CSA B149.10, SECT. 8.14.
  - 5) DETAIL "B" INSTALL WIND DEFLECTOR VANE IN 2" PVC COUPLING IN VERTICAL POSITION USING PVC SOLVENT.
  - 6) THE COMBUSTION AIR TERMINATION MUST BE IN THE SAME PRESSURE ZONE AS THE EXHAUST TERMINATION.
  - 7) NO SCREENS MAY BE USED TO COVER COMBUSTION AIR OR EXHAUST.
  - 8) NO T'S CAN BE INSTALLED AT THE TERMINATION.
  - 9) WALL PENETRATION AND VENT TERMINATIONS MUST BE WITH 2" Ø PIPE.

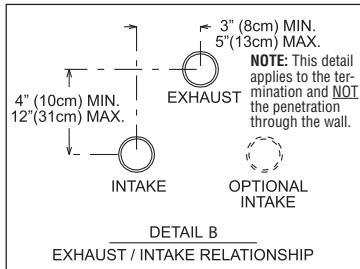

ST-A1194-18-XO  
FIGURE K &  
DETAILS B & C

### OPTION 3: VARIANT OF STANDARD HORIZONTAL DIRECT-VENT TERMINATION

**FIGURE 25**  
VARIANT OF STANDARD HORIZONTAL DIRECT-VENT TERMINATION  
**OPTION A ONLY**

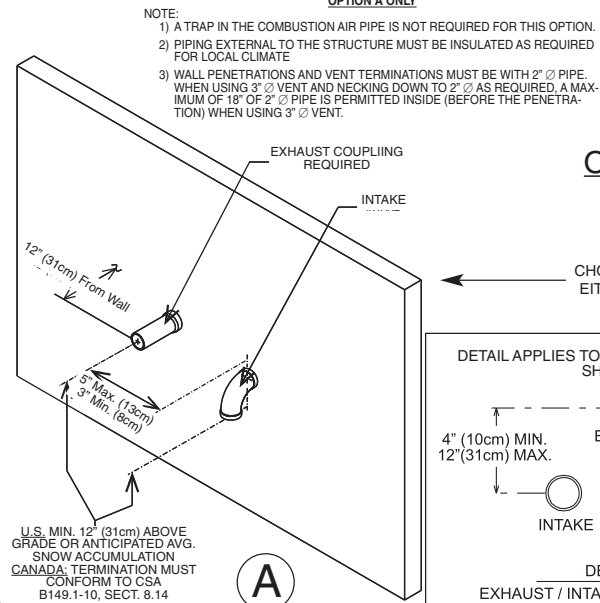

OR

CHOOSE EITHER

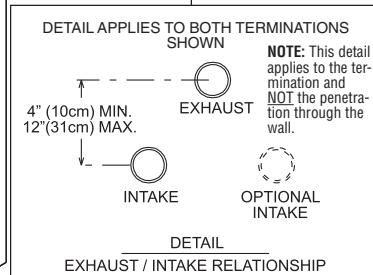

**OPTION B ONLY**

- NOTE:**
1. A TRAP MUST BE INSTALLED IN THIS OPTION TO PREVENT WATER FROM ENTERING THE FURNACE THROUGH THE COMBUSTION AIR PIPE. ORDER KITS RXGY-D05 FOR 2" PIPE OR RXGY-D06 FOR 3" PIPE AND INSTALL PER INSTRUCTIONS IN KIT.
  2. PIPING EXTERNAL TO THE STRUCTURE MUST BE INSULATED FOR LOCAL CLIMATES.
  3. WALL PENETRATIONS AND VENT TERMINATIONS MUST BE WITH 2" Ø PIPE. A MAXIMUM OF 18" OF 2" Ø PIPE IS PERMITTED INSIDE (BEFORE THE PENETRATION) WHEN USING 3" Ø VENT.

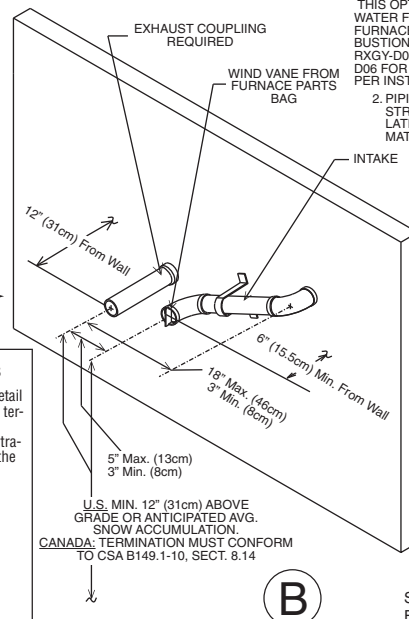

ST-A1194-18-XO  
FIGURES O, Q &  
DETAIL C

# GENERAL VENTING REQUIREMENTS AND GUIDELINES

## DIRECT VENT (cont.)

### OPTION 4: ALTERNATE HORIZONTAL DIRECT-VENT TERMINATION

**FIGURE 26**  
TYPICAL HORIZONTAL VENTED 2 PIPE TERMINALS

**NOTE:**  
1) FOR EXHAUST / INTAKE PENETRATION DIMENSIONAL RELATIONSHIP SEE DETAIL C

EXHAUST  
INTAKE

U.S. MIN. 12" (31cm) ABOVE GRADE OR ANTICIPATED AVG. SNOW ACCUMULATION CANADA: TERMINATION MUST CONFORM TO CSA B149.1-10, SECT. 8.14

VANE  
2" PVC COUPLING  
COMBUSTION AIR TERMINATION  
DETAIL A

1  
2  
3  
SUPPLY AIR  
EXHAUST PIPE  
COMBUSTION AIR PIPE  
2" OR 3" TEE W/ DRAIN TRAP  
TRAP  
CONNECT TO DRAIN  
12" (31cm) MAX.  
SEE DETAIL B FOR DIMENSIONS BETWEEN INTAKE & EXHAUST  
8" (20cm) MIN.  
SEE DETAIL A COUPLINGS: REQUIRED ON EXTERIOR, OPTIONAL ON INTERIOR.

**NOTE:**  
A TRAP MUST BE INSTALLED IN THIS OPTION TO PREVENT WATER FROM ENTERING THE FURNACE THROUGH THE COMBUSTION AIR PIPE. ORDER KITS RXGY-005 FOR 2" PIPE OR RXGY-D6 FOR 3" PIPE AND INSTALL PER INSTRUCTIONS IN KIT.

**NOTES:**  
1) SUPPORT HORIZONTAL PIPE EVERY FOUR FEET.  
2) WHEN 3" PIPE IS USED REDUCE TO 2" BEFORE PENETRATING OUTSIDE WALL.  
3) WHEN USING 3" Ø VENT AND NECKING DOWN AS REQUIRED, 18" (46cm) MAX. 2" DIA. PIPE MAY BE USED INSIDE WALL.  
4) INCREASE THE 12" (31cm) MIN. ABOVE GRADE (U.S.) TO KEEP TERMINAL OPENINGS ABOVE ANTICIPATED LEVEL OF SNOW ACCUMULATION WHERE APPLICABLE. CANADA: REFER TO B149.1, SECT. 8.14.  
5) DETAIL "A" INSTALL WIND DEFLECTOR VANE IN 2" PVC COUPLING IN VERTICLE POSITION USING PVC SOLVENT.  
6) THE COMBUSTION AIR TERMINATION MUST BE IN THE SAME PRESSURE ZONE AS THE EXHAUST TERMINATION.  
7) NO SCREENS MAY BE USED TO COVER COMBUSTION AIR OR EXHAUST.  
8) NO T'S CAN BE INSTALLED AT THE TERMINATION.  
9) PIPING EXTERNAL TO THE STRUCTURE MUST BE INSULATED AS REQUIRED FOR LOCAL CLIMATE.  
10) WALL PENETRATION AND VENT TERMINATION MUST BE WITH 2" Ø PIPE.

4" (10cm) MIN. 12" (31cm) MAX.  
EXHAUST  
INTAKE  
OPTIONAL INTAKE  
DETAIL B  
EXHAUST / INTAKE RELATIONSHIP

**NOTE:** This detail applies to the termination and NOT the penetration through the wall.

3 IN (8cm) MIN.  
5 IN (13cm) MAX.

ST-A1194-18-XO  
FIGURES M, L, & DETAILS B & C.

### OPTION 5: VARIANT OF ALTERNATE HORIZONTAL DIRECT-VENT TERMINATION

**FIGURE 27**  
VARIANT OF ALTERNATE HORIZONTAL DIRECT-VENT TERMINATION

**NOTE:**  
1. A TRAP MUST BE INSTALLED IN THIS OPTION TO PREVENT WATER FROM ENTERING THE FURNACE THROUGH THE COMBUSTION AIR PIPE. ORDER KITS RXGY-D05 FOR 2" PIPE OR RXGY-D06 FOR 3" PIPE AND INSTALL PER INSTRUCTIONS IN KIT.  
2. PIPING EXTERNAL TO THE STRUCTURE MUST BE INSULATED FOR LOCAL CLIMATES  
3. WALL PENETRATION AND VENT TERMINATIONS MUST BE WITH 2" Ø PIPE. WHEN USING 3" Ø VENT AND NECKING DOWN AS REQUIRED, A MAXIMUM OF 18" OF 2" Ø PIPE IS PERMITTED INSIDE (BEFORE THE PENETRATION) WHEN USING 3" Ø VENT.

**OPTION A ONLY**

EXHAUST  
INTAKE  
WIND VANE FROM FURNACE PARTS BAG  
6" (15.5cm) Min. From Wall  
12" (31cm) From Wall  
5" Max. (13cm) 3" Min. (8cm)  
60" Max. (152cm)  
U.S. MIN. 12" (31cm) ABOVE GRADE OR ANTICIPATED AVG. SNOW ACCUMULATION CANADA: TERMINATION MUST CONFORM TO CSA B149.1-10, SECT. 8.14  
A

**OR**

CHOOSE EITHER

**OPTION B ONLY**

EXHAUST  
INTAKE  
12" (31cm)  
60" Max. (152cm)  
5" Max. (13cm) 3" Min. (8cm)  
U.S. MIN. 12" (31cm) ABOVE GRADE OR ANTICIPATED AVG. SNOW ACCUMULATION CANADA: TERMINATION MUST CONFORM TO CSA B149.1-10, SECT. 8.14  
U.S. MIN. 12" (31cm) ABOVE GRADE OR ANTICIPATED AVG. SNOW ACCUMULATION CANADA: TERMINATION MUST CONFORM TO CSA B149.1-10, SECT. 8.14  
B

DETAIL APPLIES TO BOTH TERMINATIONS SHOWN

4" (10cm) MIN. 12" (31cm) MAX.  
EXHAUST  
INTAKE  
OPTIONAL INTAKE  
DETAIL  
EXHAUST / INTAKE RELATIONSHIP

**NOTE:** This detail applies to the termination and NOT the penetration through the wall.

ST-A1194-18-XO  
FIGURES N & P & DETAIL C

# GENERAL VENTING REQUIREMENTS AND GUIDELINES

## DIRECT VENT (cont.)

### OPTIONAL TERMINATION ANGLES FOR OPTION FOR ALT. HORIZ. AND VARIANT OF ALT. HORIZ. DIRECT-VENT TERMINATIONS (OPTIONS 4 & 5)

**NOTE:** THESE OPTIONAL TERMINATION ANGLES APPLY ONLY TO DIRECT-VENT TERMINATION OPTIONS 4 AND 5 ABOVE (ALTERNATE HORIZONTAL AND VARIANT OF OPTIONAL HORIZONTAL) IN THIS SECTION. DO NOT USE THESE ANGLED TERMINATIONS WITH ANY OTHER TERMINATION OPTION.

**NOTE:** This option is recommended for installations where the distance from the vent pipe perpendicular to another structure is less than 10 feet.

TOP VIEW FOR USING 22° OR 45° TERMINATION ON A SINGLE FURNACE

USING ALTERNATE VENT TERMINATIONS FROM OPTIONS 4 OR 5 ABOVE, SIMPLY ROTATE THE FINAL ELBOWS 22 OR 45 DEGREES FROM THE WALL AS SHOWN ABOVE.

1. BOTH THE COMBUSTION AIR AND EXHAUST FINAL TERMINATION ELBOWS MUST BE AT THE SAME ANGLE AND FACE THE SAME DIRECTION (LEFT OR RIGHT).
2. A WIND VANE MUST BE INSTALLED IN THE COMBUSTION AIR INLET PIPE AS SHOWN IN THE DIAGRAM.
3. NUMBER AND DISTANCE BETWEEN (RECOMMENDED) SUPPORT STRAPS MUST PROVIDE RIGID SUPPORT.

4. MARK THE FINAL (22° OR 45°) ANGLES ON THE TOP OF THE VERTICAL RISERS AND FINAL ELBOWS BEFORE GLUING INTO PLACE TO ENSURE THAT THE FINAL ANGLES ARE CORRECT.
5. INSULATING THE EXHAUST TERMINATION VERTICAL RISER MAY BE NECESSARY IN SOME AREAS, DEPENDING ON THE TOTAL LENGTH AND EXPECTED TEMPERATURES IN THE AREA.
6. DO NOT ANGLE (22° OR 45°) INTO AN INSIDE CORNER.
7. DO NOT USE SCREENS ON THE INLET OR EXHAUST PIPES.
8. ANGLED TERMINATIONS CANNOT BE USED ON PAIRS OF VENTS.
9. THIS TERMINATION MAY CAUSE DISCOLORATION OVER TIME TO THE EXTERNAL SURFACE OF THE STRUCTURE.
10. WALL PENETRATIONS AND VENT TERMINATIONS MUST BE WITH 2" Ø PIPE TO REDUCE THE POSSIBILITY OF ICE FORMING AT THE TERMINATION. A MAXIMUM OF 18" OF 2" Ø PIPE IS PERMITTED INSIDE (BEFORE THE PENETRATION) WHEN USING 3" Ø VENT.

FIGURE 28

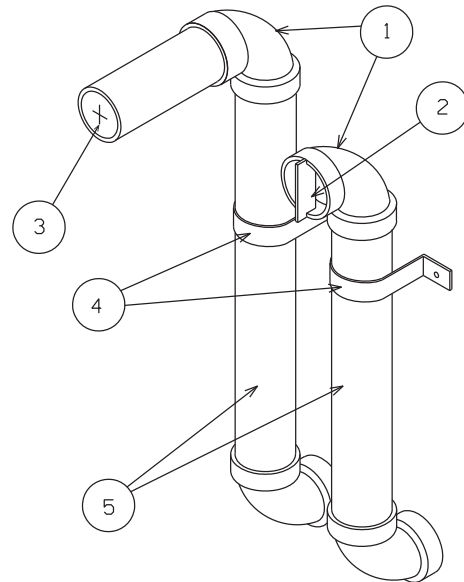
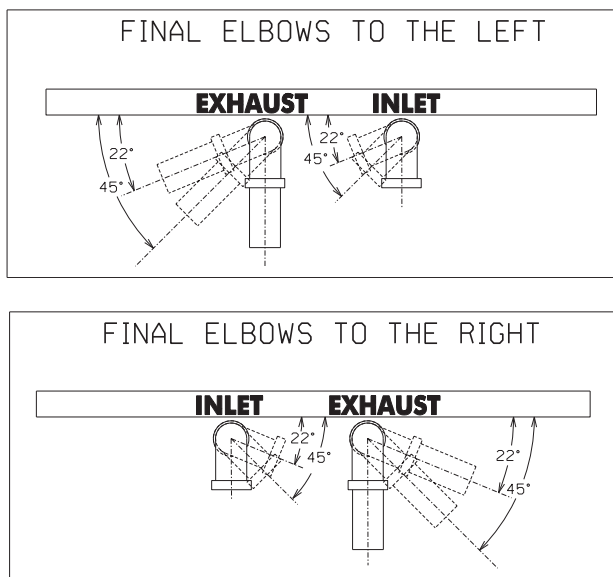

ST-A1194-20

# GENERAL VENTING REQUIREMENTS AND GUIDELINES

## DIRECT VENT (cont.)

### OPTIONS 6 & 7: VERTICAL OR HORIZONTAL CONCENTRIC VENT TERMINATION FOR 2" PIPE: RXGY-E02 (U.S. ONLY) OR RXGY-E02A (U.S. AND CANADA) FOR 3" PIPE: RXGY-E03 (U.S. ONLY) OR RXGY-E03A (U.S. AND CANADA)

#### CONCENTRIC TERMINATIONS

These kits are for vertical/horizontal intake air/vent runs and may be installed through roofs or sidewalls. One 5 inch diameter hole (RXGY-E03 & RXGY-E03A) or 3-5/8 inch diameter hole (RXGY-E02 & RXGY-E02A) is required for the installation. See **Figure 29** for the general layout. Complete instructions are included with each kit.

**NOTE:** The following IPEX brand concentric vent termination (System 636) may be purchased in the field and used in place of the kits offered by the furnace manufacturer.

3" Concentric Vent Kit = Item #196006

**NOTE:** Maximum equivalent lengths specified in the **VENT PIPE SIZING AND MAXIMUM VENT LENGTHS** section of this manual are in addition to the concentric vent.

**NOTE:** With this option a trap on the inlet air pipe is NOT required.

**FIGURE 29**  
CONCENTRIC VENT KIT NO. RXGY-E02A (2") AND RXGY-E03A (3")

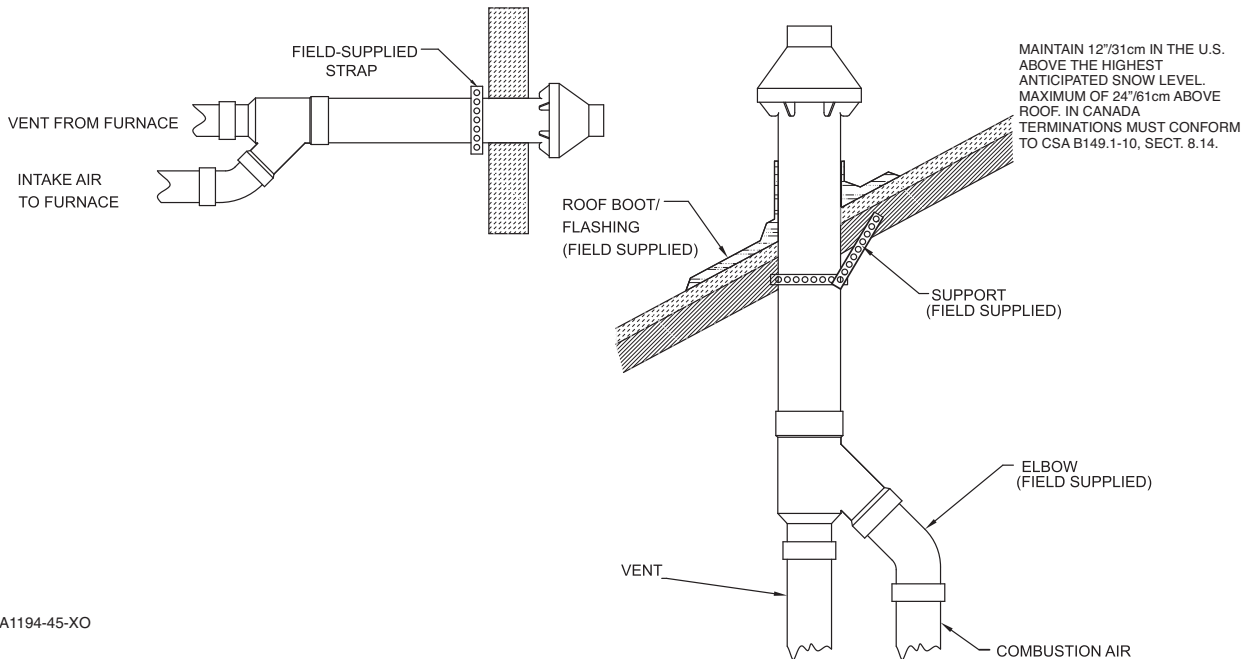

ST-A1194-45-XO

# GENERAL VENTING REQUIREMENTS AND GUIDELINES

## DIRECT VENT (cont.)

### OPTIONS 8 & 9: 2" & 3" SIDE WALL VENT TERMINATIONS

FOR 2" PIPE: RXGY-G02

FOR 3" PIPE: RXGY-G01

This termination is for horizontal venting only. This termination may be installed with either a non-direct-vent or a direct-vent system. When installed as non-direct vent, only one wall penetration is necessary for the exhaust vent.

**IMPORTANT:** Do not install on the prevailing winter wind side of the structure.

**IMPORTANT:** Maintain a minimum of 12 inches (U.S.) above grade or the highest anticipated average snow level (whichever is greater) to the bottom of the vent cover or, in Canada, terminations must conform with CSA B149.1-10, Sect. 8.14, Canadian Natural Gas and Propane Installation Code.

**NOTE:** Dimensions between the inlet and outlet pipes (direct-vent only) are fixed by the sidewall termination. Other drawings in this manual which specify minimum and/or maximum distances (vertical and horizontal) between pipes do not apply to the sidewall termination kit.

**NOTE:** Multiventing – NO COMMON VENTING IS PERMITTED WITH THIS KIT.

**NOTE:** With this option a trap on the inlet combustion air pipe is NOT required.

**NOTE:** Install the vent and air intake piping into the vent plate openings. Seal all gaps between the pipes and wall. **BE SURE TO USE SILICONE SEALANT** to seal the vent pipe to the vent cap to permit field disassembly for annual inspection and cleaning. Also seal all pipe penetrations in the wall. **DO NOT INSTALL VENT KITS ONE ABOVE THE OTHER** to prevent the possibility of condensate freeze-up or recirculation.

**NOTE:** Vent should protrude a maximum of 2-1/4 inches beyond the vent plate. Air intake should protrude a maximum of 1 inch beyond the vent plate.

**NOTE:** The RXGY-G02 termination can be used with 3" vent pipe. A maximum of 18" of 2" Ø pipe can be used before penetrating the wall.

Complete installation instructions are included with these kits.

**FIGURE 30**  
VENT KIT INSTALLATION OPTIONS

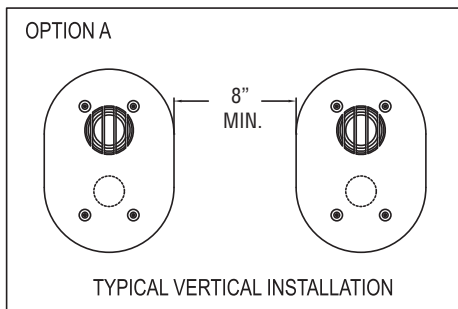

ST-A1194-46

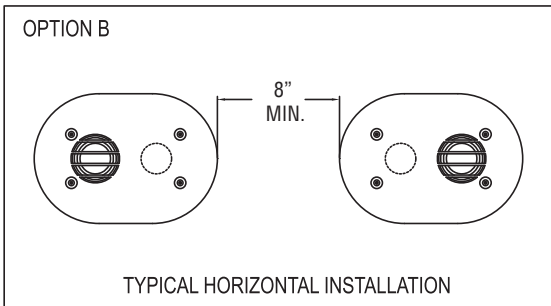

**FIGURE 31**  
TYPICAL INSTALLATION – DIRECT VENT

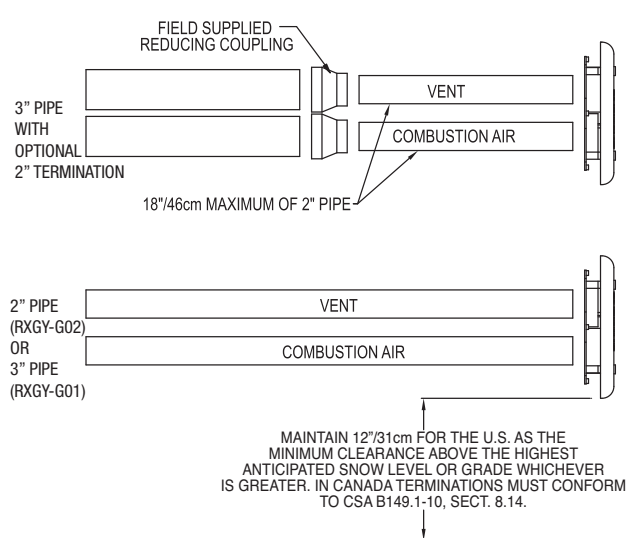

ST-A1194-46

# GENERAL VENTING REQUIREMENTS AND GUIDELINES

## DIRECT VENT TERMINATION CLEARANCES

Figure 32 shows minimum clearances that must be used for direct venting terminations.

**FIGURE 32**  
DIRECT VENT TERMINAL CLEARANCES

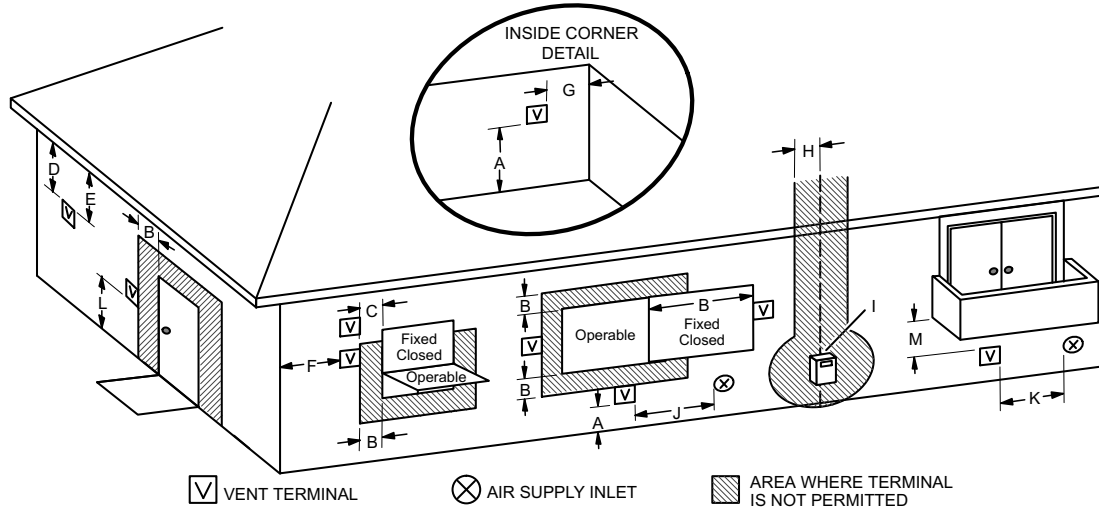

	US Installations <sup>1</sup>	Canadian Installations <sup>2</sup>
A = Clearance above grade, veranda, porch, deck or balcony	12 inches (305mm) or 12 in. 305mm) above average snow accumulation.	Must conform to CSA B149.1-10, Sect. 8.14.
B = Clearance to window or door that may be opened	6 inches (152mm) for appliances <10,000 Btuh (3kw), 12 inches (305mm) for appliances >10,000 Btuh (3kw) and <100,000 Btuh (30kw), 36 inches (.9m) for appliances > 100,000 Btuh (30kw)	6 inches (15cm) for appliances <10,000 Btuh (3kw), 12 inches (305mm) for appliances >10,000 Btuh (3kw), and <100,000 Btuh (30kw), 36 inches (.9m) for appliances > 100,000 Btuh (30kw)
C = Clearance to permanently closed window	* 12" (30cm)	* 12" (30cm)
D = Vertical clearance to ventilated soffit located above the terminal within a horizontal distance of 2 feet (0.6m) from the center line of the terminal	* Equal to or greater than soffit depth	* 3 ft. (0.9m)
E = Clearance to unventilated soffit	* Equal to or greater than soffit depth	* 2 ft. (0.6m)
F = Clearance to outside corner	* No minimum to outside corner	* No minimum to outside corner
G = Clearance to inside corner	* 3 ft. (.9m), 10 ft. (3.05 m) preferred	* 3 ft. (.9m), 10 ft. (3.05m) preferred
H = Clearance to each side of center line extended above meter / regulator assembly	3 feet (.9m) within a height 15 feet (4.5m) above the meter / regulator assembly	3 feet (.9m) within a height 15 feet (4.5m) above the meter / regulator assembly
I = Clearance to service regulator vent outlet	3 feet (.9m)*	*3 feet (.9m)
J = Clearance to non-mechanical air supply inlet to building or the combustion air inlet to any other appliance	6 inches (152mm) for appliances <10,000Btuh (3kw), 12 inches (305mm) for appliances > 10,000 Btuh (3kw) and <100,000 Btuh (30kw), 36 inches (.9m)for appliances > 100,000 Btuh (30kw)	6 inches (15cm) for appliances <10,000Btuh (3kw), 12 inches (30cm) for appliances > 10,000 Btuh (3kw) and <100,000 Btuh (30kw), 36 inches (.9m)for appliances > 100,000 Btuh (30kw)
K = Clearance to mechanical air supply inlet	3 feet (.9m) above if within 10 feet (3m) horizontally	6 feet (1.8m)
L = Clearance above paved sidewalk or paved driveway located on public property	* 7 feet (2.1m)	7 feet (2.1m)†
M = Clearance under veranda, porch, deck or balcony	*12 inches (305mm)‡	12 inches (30cm) ‡

<sup>1</sup> In accordance with the current ANSI Z223.1/NFPA 54 Natural Fuel Gas Code

<sup>2</sup> In accordance with the current CSA B149.1, Natural Gas and Propane Installation Code

† Vent shall not terminate less than 7 ft. (2.1m) above a paved sidewalk or paved driveway that is located on public property.

‡ Permitted only if veranda, porch, deck or balcony is full open on a minimum of two sides beneath the floor. We recommend avoiding this location if possible.

\*For clearances not specified in ANSI Z223.1/NFPA 54 or CSA B149.1, clearance will be in accordance with local installation codes and the requirements of the gas supplier and these installation instructions."

# GENERAL VENTING REQUIREMENTS AND GUIDELINES

## MULTIVENTING OF DIRECT-VENT FURNACES

**Figures 33 & 34:** NOTE: WHEN VENTING MULTIPLE FURNACES IN CLOSE PROXIMITY, EACH FURNACE MUST BE INDIVIDUALLY VENTED – NO COMMON VENTING IS PERMITTED. See **Figures 33 & 34** for positioning of the terminations. When more than two furnaces are to be vented, there must be at least 4 feet between the first two furnaces and the third and etc. **Figure 33, (Detail A)** below shows the necessary detail for the roof penetration on a standard direct-vent vertical termination.

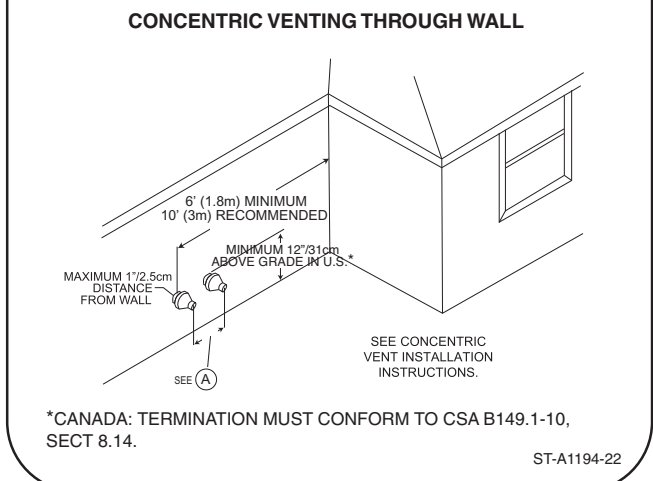
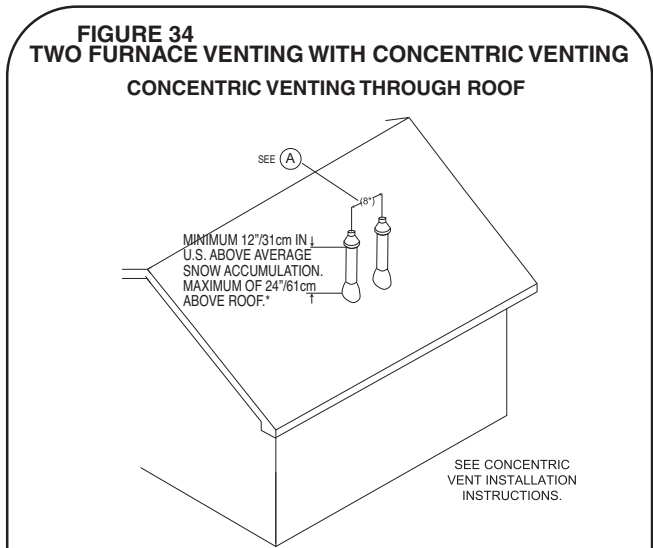
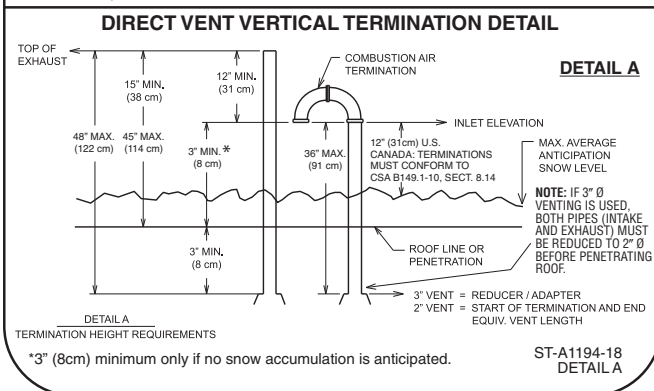
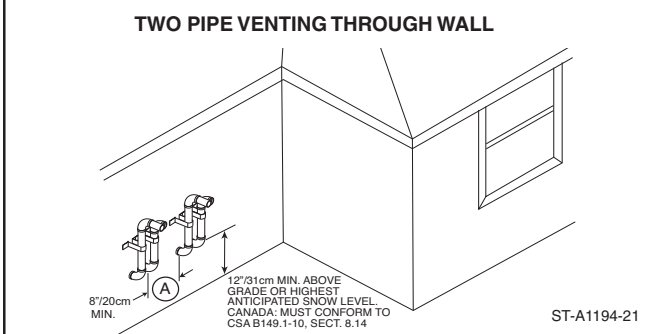
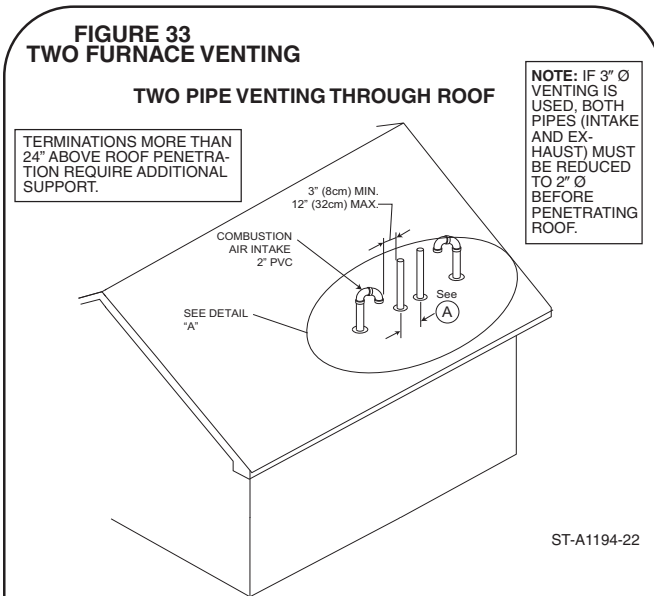

- (A)**
- 2 FURNACES**
- Terminations must be greater than 8" apart.
  - Terminations must be less than 24" apart or greater than 36" apart.
- 3rd OR MORE FURNACES**
- Each additional termination must be greater than 48" from the previous termination.

# CONDENSATE DRAIN

## CONDENSATE DRAIN & DRAIN NEUTRALIZER

### GENERAL INFORMATION

#### CAUTION

**DO NOT RUN DRAIN OUTDOORS. FREEZING OF CONDENSATE CAN CAUSE PROPERTY DAMAGE.**

**IMPORTANT:** Do not connect into a common drain line with an air conditioner evaporator coil drain located below the furnace. A blocked or restricted drain line can result in overflow of the coil pan and negate the furnace blocked drain shutoff control.

The condensate drain trap is self-priming. Upon the first heat attempt after installation or the first ignition after a long off period (e.g. summer), the trap will be dry allowing air to pull through the trap and causing the condensate to be held in the collector box by the negative pressure while the inducer is energized.

Condensate builds up in the collector box until the level reaches the electronic water level sensor. When this happens the heat attempt is ended thus shutting off the inducer after a post purge. This relieves the negative pressure pulled through the trap and the water then falls into the trap generally priming it after the first time. Note that in some circumstances this process may be repeated up to four times before the trap is fully primed – particularly in horizontal installations where there is less volume of water in the collector box below the water level sensor.

**Important:** There are two options when choosing a height for the condensate vent riser (also see Figure 35):

**A. CONDENSATE OVERFLOW** – When the top of the vent tube is below the elevation of the LOWER condensate water level sensor (aka electronic water level sensor) the furnace will continue to run even if the drain is blocked. A blocked drain will cause the condensate water to overflow the vent and spill water on the floor below it but the furnace will continue to run and heat will be provided. If the installer uses this approach, he must make sure that there is a mechanism for handling the possibility of water overflow onto the floor in the event of a blocked drain.

**B. FURNACE SHUTOFF** – When the top of the vent tube is above the elevation of the LOWER condensate water level sensor (aka electronic water level sensor), the furnace will be shut off in the event of a blocked drain and no heat will be provided.

**NOTE:** IT IS IMPORTANT ANY TIME THE FURNACE IS INSTALLED IN AN ENVIRONMENT WHERE THE TEMPERATURE CAN GET BELOW FREEZING THAT THE TRAP AND ALL CONDENSATE LINE BE PROTECTED FROM FREEZING. IF THE FURNACE IS EXPOSED TO TEMPERATURES BELOW FREEZING, THE TRAP WILL FREEZE AND THIS WILL CAUSE THE FURNACE TO SHUT DOWN AND/OR DAMAGE THE DRAIN TRAP UNLESS FREEZE PROTECTION IS INSTALLED.

If local codes require, install a condensate neutralizer cartridge in the drain line. Install cartridge in horizontal position only. Also install an overflow line if routing to a floor drain. See Figure 35.

If no floor drain is available, install a condensate pump that is resistant to acidic water. Pumps are available from your local distributor. If pump used is not resistant to acidic water, a condensate neutralizer must be used ahead of the pump. The condensate pump must have an auxiliary safety switch to prevent operation of the furnace and resulting overflow of condensate in the event of pump failure. The safety switch must be wired through the “R” circuit only (low voltage) to provide operation in either heating or cooling modes.

# CONDENSATE DRAIN

## CONDENSATE DRAIN & DRAIN NEUTRALIZER (cont.)

FIGURE 35

NOTE: THESE IMAGES INTENTIONALLY DEPICT GENERIC VIEWS OF THE DRAIN ROUTING. THE INSTALLER HAS THE OPTION TO ROUTE THE DRAIN TO THE RIGHT OR LEFT SIDE OF THE FURNACE AS NEEDED.

### CONDENSATE DRAIN LOCATING INSTRUCTIONS

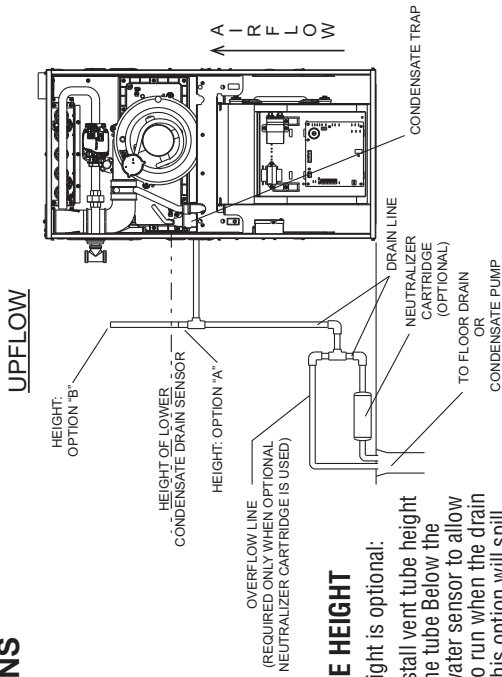
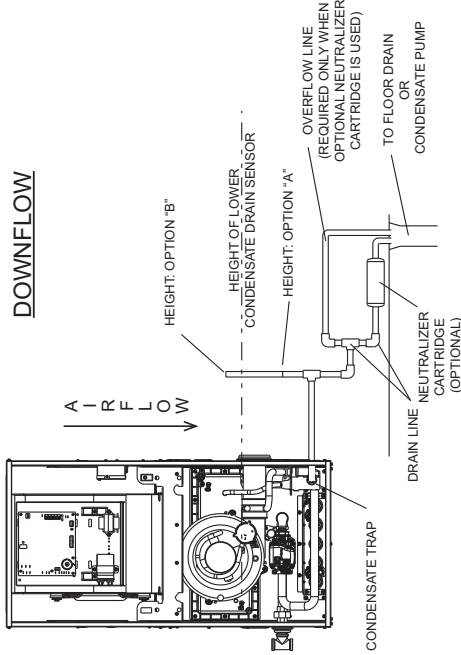

#### VENT TUBE HEIGHT

Vent tube height is optional:

**Option A:** Install vent tube height with top of the tube Below the level of the water sensor to allow the furnace to run when the drain is blocked. This option will spill water out of the tube when the drain is blocked, but the furnace will continue to run.

**Option B:** Install vent tube height with top of the tube Above the level of the lower condensate water sensor to shut the furnace down when the drain is blocked. This option will not spill water from the drain vent but the furnace will also not continue to run with a blocked drain.

#### HORIZONTAL LEFT

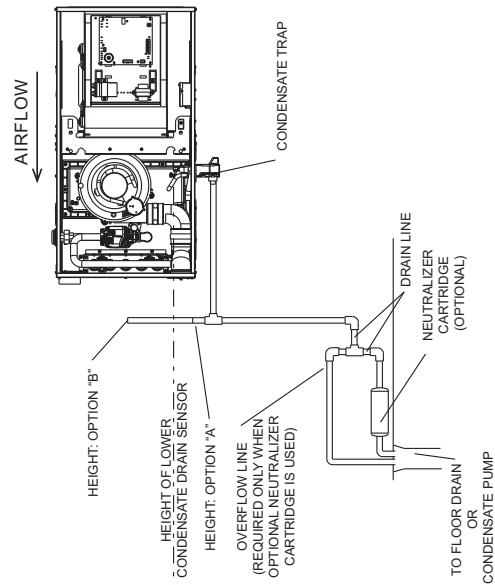

#### HORIZONTAL RIGHT

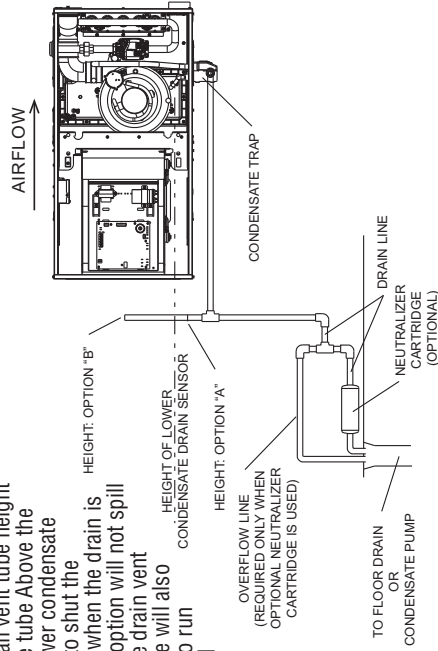

ST-A1194-42-X0

## GAS SUPPLY AND PIPING

### IMPORTANT SAFETY INFORMATION

### NATURAL GAS AND PROPANE (LIQUEFIED PETROLEUM GAS / LPG) SAFETY

### GAS SUPPLY

#### WARNING

- FURNACES USING PROPANE GAS ARE DIFFERENT FROM NATURAL GAS MODELS. A NATURAL GAS HEATER WILL NOT FUNCTION SAFELY ON PROPANE AND VICE VERSA. CONVERSIONS OF HEATER GAS TYPE SHOULD ONLY BE MADE BY QUALIFIED INSTALLERS USING FACTORY SUPPLIED COMPONENTS. THE FURNACE SHOULD ONLY USE THE FUEL TYPE IN ACCORDANCE WITH LISTING OR RATING PLATE. ANY OTHER FUEL USAGE WILL RESULT IN DEATH OR SERIOUS PERSONAL INJURY FROM FIRE AND/OR EXPLOSION.
- BOTH NATURAL GAS AND PROPANE HAVE AN ODORANT ADDED TO AID IN DETECTING A GAS LEAK. SOME PEOPLE MAY NOT PHYSICALLY BE ABLE TO SMELL OR RECOGNIZE THIS ODORANT. IF YOU ARE UNSURE OR UNFAMILIAR WITH THE SMELL OF NATURAL GAS OR PROPANE, ASK YOUR LOCAL GAS SUPPLIER. OTHER CONDITIONS, SUCH AS "ODORANT FADE," WHICH CAUSES THE ODORANT TO DIMINISH IN INTENSITY, CAN ALSO HIDE, CAMOUFLAGE, OR OTHERWISE MAKE DETECTING A GAS LEAK BY SMELL MORE DIFFICULT.
- UL OR CSA RECOGNIZED FUEL GAS DETECTORS ARE RECOMMENDED IN ALL ENCLOSED PROPANE AND NATURAL GAS APPLICATIONS WHEREIN THERE IS A POTENTIAL FOR AN EXPLOSIVE MIXTURE OF FUEL GAS TO ACCUMULATE. FUEL DETECTOR INSTALLATION SHOULD BE IN ACCORDANCE WITH THE DETECTOR MANUFACTURER'S RECOMMENDATIONS AND/OR LOCAL LAWS, RULES, REGULATIONS, OR CUSTOMS.
- BEFORE ATTEMPTING TO LIGHT THE FURNACE, MAKE SURE TO LOOK AND SMELL FOR GAS LEAKS. USE A SOAPY SOLUTION TO CHECK ALL GAS FITTINGS AND CONNECTIONS.

BUBBLING AT A CONNECTION INDICATES A LEAK THAT MUST BE CORRECTED. WHEN SMELLING TO DETECT A GAS LEAK, BE SURE TO ALSO SNIFF NEAR THE FLOOR. PROPANE GAS IS HEAVIER THAN AIR AND TENDS TO COLLECT AT LOWER LEVELS MAKING IT MORE DIFFICULT TO SMELL AT NOSE LEVEL. NATURAL GAS IS LIGHTER THAN AIR

*(Continued on next column)*

AND WILL RISE, POSSIBLY ACCUMULATING IN HIGHER PORTIONS OF THE STRUCTURE.

- IF A GAS LEAK IS PRESENT OR SUSPECTED:
  - DO NOT ATTEMPT TO FIND THE CAUSE YOURSELF.
  - NEVER USE AN OPEN FLAME TO TEST FOR GAS LEAKS. THE GAS CAN IGNITE RESULTING IN DEATH, PERSONAL INJURY, OR PROPERTY DAMAGE.
  - DO NOT TRY TO LIGHT ANY APPLIANCE.
  - DO NOT TOUCH AND ELECTRICAL SWITCH.
  - DO NOT USE ANY PHONE IN YOUR BUILDING.
  - LEAVE THE BUILDING IMMEDIATELY AND CALL THE GAS SUPPLIER FROM A NEIGHBOR'S PHONE. FOLLOW THE GAS SUPPLIER'S INSTRUCTIONS.
  - IF YOU CANNOT REACH YOUR GAS SUPPLIER, CALL THE FIRE DEPARTMENT.
  - DO NOT RETURN TO THE BUILDING UNTIL AUTHORIZED BY THE GAS SUPPLIER OR FIRE DEPARTMENT.
- SHOULD OVERHEATING OCCUR OR THE GAS SUPPLY FAIL TO SHUT OFF, TURN OFF THE MANUAL GAS CONTROL VALVE TO THE FURNACE.
- CONSULT WITH THE LOCAL BUILDING DEPARTMENT AND FUEL GAS SUPPLIER BEFORE INSTALLING THE HEATER:
  - THE INSTALLATION AND PURGING OF GAS PIPING MUST CONFORM TO LOCAL CODES, UTILITY COMPANY REQUIREMENTS, AND THE LATEST EDITION OF NATIONAL FUEL GAS CODE (NFGC) - ANSI Z223.1/NFPA 54, OR CSA B149.1, NATURAL GAS AND PROPANE INSTALLATION CODE.
  - LP FURNACES SHOULD NOT BE INSTALLED BELOW GRADE (IN A BASEMENT FOR EXAMPLE) IF SUCH INSTALLATION IS PROHIBITED BY FEDERAL, STATE, PROVINCIAL, AND/OR LOCAL LAWS, RULES, REGULATIONS, OR CUSTOMS.
  - INSTALLATION OF A GAS PRESSURE REGULATOR MAY BE REQUIRED IN THE GAS SUPPLY LINE. THE REGULATOR SHOULD NOT EXCEED THE MAXIMUM SUPPLY PRESSURE LISTED ON THE FURNACE RATING PLATE. DO NOT USE AN INDUSTRIAL-TYPE GAS REGULATOR.
  - FOLLOW ALL LOCAL CODES AND SECTION 8.3 OF NFGC WITH REGARD TO PURGING OF GAS PIPING TO ENSURE THAT THE AIR AND/OR FUEL GAS IN THE GAS PIPING IS PROPERLY VENTED TO A LOCATION WHERE AN EXPLOSIVE MIXTURE CANNOT ACCUMULATE.

# GAS SUPPLY

## GAS PIPING

### ⚠ WARNING

THIS FURNACE IS EQUIPPED AT THE FACTORY FOR USE ON NATURAL GAS ONLY. CONVERSION TO LP GAS REQUIRES A SPECIAL KIT IS AVAILABLE AT THE DISTRIBUTOR. FAILURE TO USE THE PROPER CONVERSION KIT CAN CAUSE FIRE, CARBON MONOXIDE POISONING, EXPLOSION, PROPERTY DAMAGE, PERSONAL INJURY OR DEATH. SEE THE CONVERSION KIT INDEX SUPPLIED WITH THE FURNACE. THIS INDEX IDENTIFIES THE PROPER LP GAS CONVERSION KIT REQUIRED FOR EACH PARTICULAR FURNACE.

**IMPORTANT:** Any additions, changes or conversions required for the furnace to satisfactorily meet the application should be made by a qualified installer, service agency or the gas supplier, using factory-specified or approved parts.

**IMPORTANT:** Connect this furnace only to gas supplied by a commercial utility or commercial fuel provider.

**IMPORTANT:** U.L. or CSA recognized fuel gas and carbon monoxide (CO) detector(s) are recommended in all applications, and their installation should be in accordance with the manufacturer's recommendations and/or local laws, rules, regulations or customs.

Install the gas piping according to all local codes and regulations of the utility company.

If possible, run a separate gas supply line directly from the meter to the furnace. Consult the local gas company for the location of the manual main shut-off valve. **The gas line and manual gas stop must be adequate in size to prevent undue pressure drop and never smaller than the pipe size to the gas valve on the furnace.** Refer to Table 12 for natural gas (Table 13 for LP gas) for the recommended gas pipe size. See Figure 36 for typical gas pipe connections.

**Install a ground joint union within 3 feet of the cabinet to easily remove the gas valve assembly. Local codes may dictate the location of the ground joint union. Install a manual shut-off valve in the gas line outside of the furnace casing and upstream of the ground joint union.** The manual shut-off valve should be readily accessible to turn the gas supply on or off. Install a drip leg in the gas supply line as close to the furnace as possible. Always use a pipe compound resistant to the action of liquefied petroleum gases on all threaded connections.

**IMPORTANT:** When making gas pipe connections, use a back-up wrench to prevent any twisting of the main gas valve and manifold. Do not overtighten gas valve on pipe.

Any strains on the gas valve can change the position of the gas orifices in the burners. This can cause erratic furnace operation.

FIGURE 36  
GAS PIPING INSTALLATION

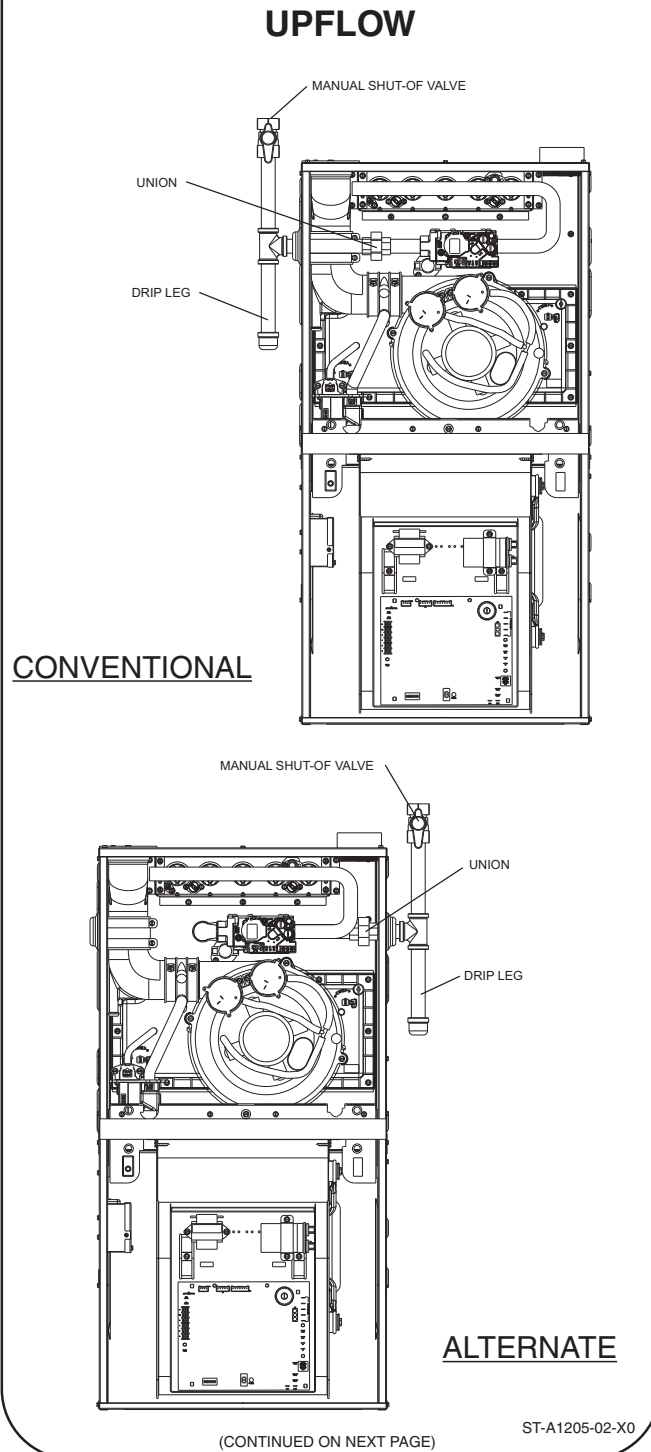

# GAS SUPPLY

## GAS PIPING

FIGURE 36 – continued  
GAS PIPING INSTALLATION

### DOWNFLOW

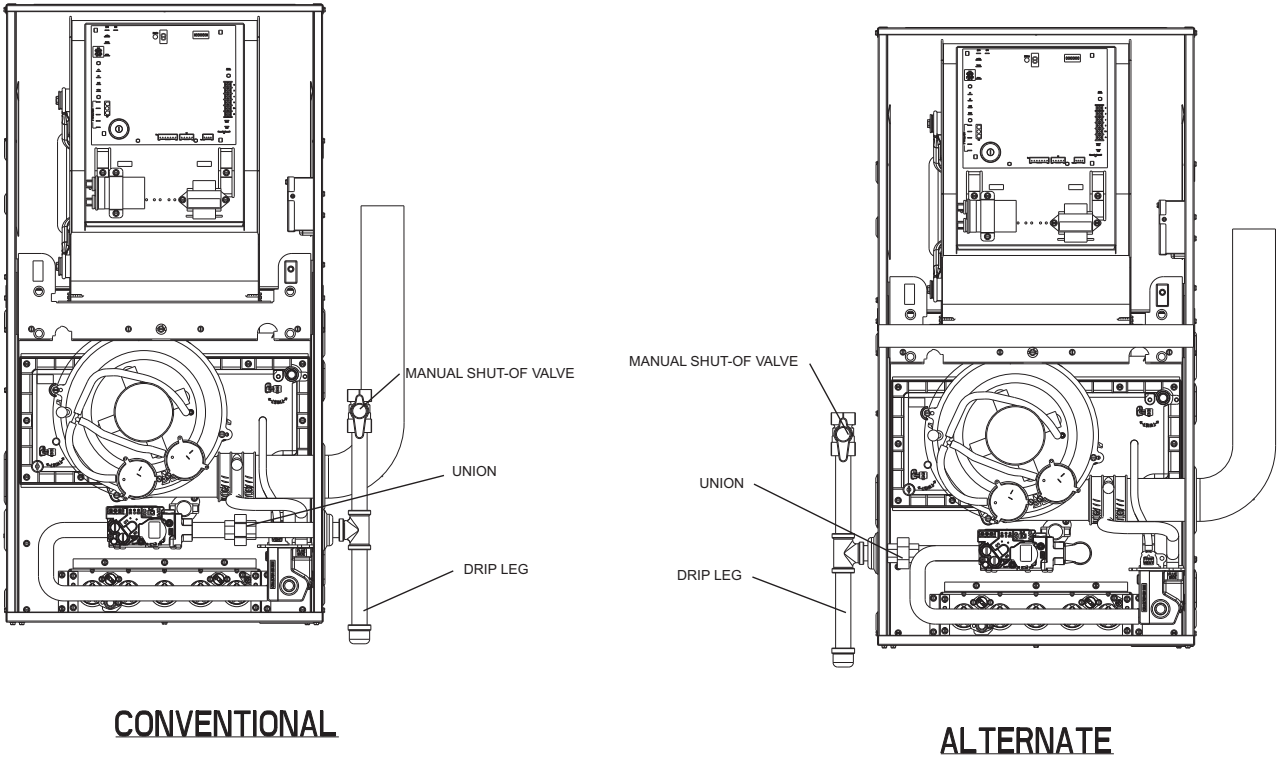

(CONTINUED ON NEXT PAGE)

ST-A1205-03-X0

# GAS SUPPLY

## GAS PIPING

FIGURE 36 – continued  
GAS PIPING INSTALLATION

### HORIZONTAL

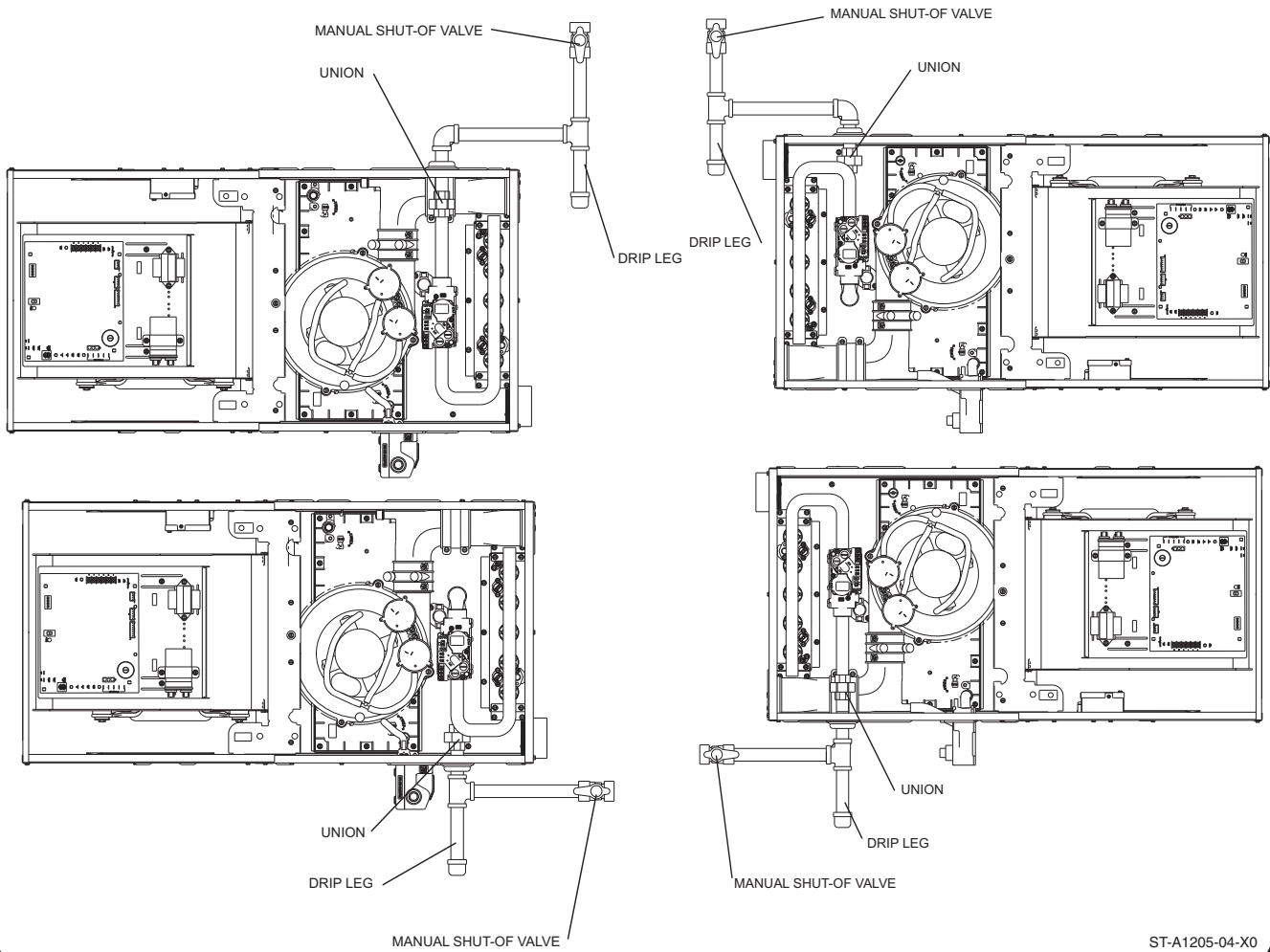

ST-A1205-04-X0

## GAS PRESSURE

**IMPORTANT:** Do not run a flexible gas connector inside the furnace. The gas pipe gasket in the cabinet does not seal around a flexible gas line.

If local codes allow the use of a flexible gas appliance connector, always use a new listed connector. Do not use a connector which has previously serviced another gas appliance. Massachusetts law requires that all flexible connectors be less than 36".

**It is important to have all openings in the cabinet burner compartment sealed for proper furnace operation.**

**IMPORTANT:** ENSURE that the furnace gas valve is not to be subjected to high gas line supply pressures.

DISCONNECT the furnace and its individual manual gas stop from the gas supply piping during **any pressure testing that exceeds 1/2 PSIG. (3.48 kPa).**

**Natural gas supply pressure must be 5" to 10.5" w.c. LP gas supply pressure must be 11" to 13" w.c. This pressure must be maintained with all other gas-fired appliances in operation.**

The minimum gas supply pressure to the gas valve for proper furnace input adjustments is 5" w.c. for natural gas, however 6" to 7" is recommended. The minimum gas supply pressure is 11" w.c. for LP gas.

### ⚠ CAUTION

**ELEVATIONS ABOVE 2000 FT. REQUIRE THAT THE FURNACE INPUT RATING BE ADJUSTED AND THAT THE SIZE OF THE BURNER ORIFICES BE RECALCULATED BASED ON ELEVATION AND GAS HEATING VALUE. THE BURNER ORIFICES MAY (OR MAY NOT) NEED TO BE CHANGED. SEE THE SECTION TITLED "HIGH ALTITUDE INSTALLATIONS" OF THIS BOOK FOR INSTRUCTIONS.**

**FIGURE 37**  
TYPICAL GAS VALVE (WHITE RODGERS)

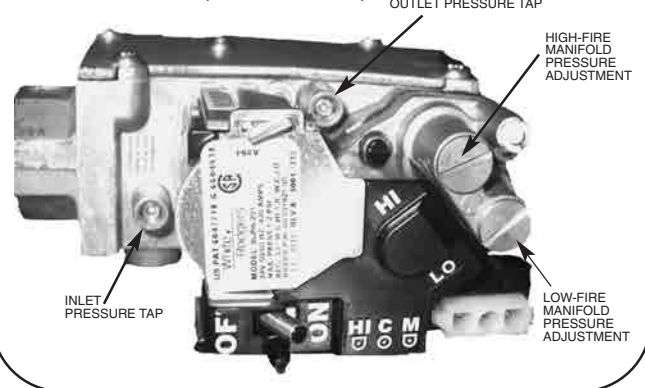

### ⚠ WARNING

**NEVER PURGE A GAS LINE INTO THE COMBUSTION CHAMBER. NEVER USE MATCHES, FLAME OR ANY IGNITION SOURCE FOR CHECKING LEAKAGE. FAILURE TO ADHERE TO THIS WARNING CAN CAUSE A FIRE OR EXPLOSION RESULTING IN PROPERTY DAMAGE, PERSONAL INJURY OR DEATH.**

**TO CHECK FOR GAS LEAKAGE, USE AN APPROVED CHLORIDE-FREE SOAP AND WATER SOLUTION, OR OTHER APPROVED METHOD.**

### GAS VALVE

This furnace has a 24-volt gas valve. It has ports for measuring supply and manifold gas pressure. The valve body contains a pressure regulator to maintain proper manifold gas pressure.

A control switch is on the valve body. It can be set to only the "ON" or "OFF" positions. The gas valve is a slow-opening valve. See Figure 37.

When energized, it takes 2 to 3 seconds to fully open.

**TABLE 12**  
NATURAL GAS PIPE CAPACITY TABLE (CU. FT./HR.)

Capacity of gas pipe of different diameters and lengths in cu. ft. per hr. with pressure drop of 0.3 in. and specific gravity of 0.60 (natural gas).

Nominal Iron Pipe Size, Inches	Length of Pipe, Feet							
	10	20	30	40	50	60	70	80
1/2	132	92	73	63	56	50	46	43
3/4	278	190	152	130	115	105	96	90
1	520	350	285	245	215	195	180	170
1-1/4	1,050	730	590	500	440	400	370	350
1-1/2	1,600	1,100	890	760	670	610	560	530

After the length of pipe has been determined, select the pipe size which will provide the minimum cubic feet per hour required for the gas input rating of the furnace. By formula:

$$\text{Cu. Ft. Per Hr. Required} = \frac{\text{Gas Input of Furnace (BTU/HR)}}{\text{Heating Value of Gas (BTU/FT}^3\text{)}}$$

The gas input of the furnace is marked on the furnace rating plate. The heating value of the gas (BTU/FT<sup>3</sup>) may be determined by consulting the local natural gas utility or the LP gas supplier.

# LP CONVERSION

**NOTE:** See Page 82 for Canadian High-Altitude Derate.

The valve can be converted to use liquified petroleum (LP) gas by replacing the pressure regulator springs with the conversion kit springs. This LP kit spring allows the regulators to maintain the proper manifold pressure for LP gas.

**NOTE:** Order the correct LP conversion kit from the furnace manufacturer. Furnace conversion to LP gas must be performed by a qualified installer, service agency or the gas supplier.

## ORIFICE INSTALLATION

LP Gas is a manufactured gas that has consistent heating value across most regions.

The Sea Level input should still be reduced by 4% per thousand ft. and the orifice size must be selected based on the reduced input selection chart in High Alt. Instruction Section.

To change orifice spuds for either conversion to LP or for elevation:

1. Shut off the manual main gas valve and remove the gas manifold.
2. Replace the orifice spuds.
3. Reassemble in reverse order.
4. Turn the gas supply back on and check for proper operation and manifold pressure.
5. Attach the notice label alerting the next service technician that the furnace has been converted to LP gas.

## WARNING

**LP TANKS FROM LOCAL LP SUPPLIER MUST NOT BE USED TO STORE ANYTHING (SUCH AS FERTILIZER) EXCEPT LP GAS. THIS INCLUDES ALL DELIVERY VESSELS (LP TRUCKS). IF MATERIAL OTHER THAN LP GAS IS USED IN THE SAME VESSELS/TANK AS THE LP GAS, THE LP GAS CAN BECOME CONTAMINATED AND DAMAGE THE FURNACE. THIS WILL VOID THE MANUFACTURER'S WARRANTY. CONTACT THE SUPPLIER TO MAKE SURE FERTILIZER IS NOT USED IN THE SAME TANKS USED TO STORE AND DELIVER LP GAS.**

**FIGURE 38**  
TYPICAL LP KIT CONTENTS

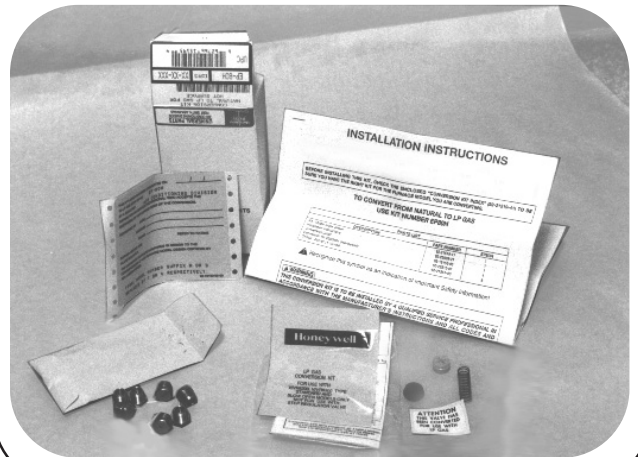

**TABLE 13**  
LP GAS PIPE CAPACITY TABLE (CU. FT./HR.)

Maximum capacity of pipe in thousands of BTU per hour of undiluted liquefied petroleum gases (at 11 inches water column inlet pressure).

(Based on a Pressure Drop of 0.5 Inch Water Column)

Nominal Iron Pipe Size, Inches	Length of Pipe, Feet											
	10	20	30	40	50	60	70	80	90	100	125	150
1/2	275	189	152	129	114	103	96	89	83	78	69	63
3/4	567	393	315	267	237	217	196	182	173	162	146	132
1	1,071	732	590	504	448	409	378	346	322	307	275	252
1-1/4	2,205	1,496	1,212	1,039	913	834	771	724	677	630	567	511
1-1/2	3,307	2,299	1,858	1,559	1,417	1,275	1,181	1,086	1,023	976	866	787
2	6,221	4,331	3,465	2,992	2,646	2,394	2,205	2,047	1,921	1,811	1,606	1,496

Example (LP): Input BTU requirement of unit, 120,000  
Equivalent length of pipe, 60 ft. = 3/4" IPS required.

## GAS PRESSURE

### SETTING GAS PRESSURE

**The maximum gas supply pressure to the furnace must not exceed 10.5" w.c. natural gas, or 13" w.c. LP gas.** The minimum supply gas pressure to the gas valve should be 5" w.c. natural gas or 11" w.c. LP gas. A properly calibrated manometer is required for accurate gas pressure measurements.

### SUPPLY GAS PRESSURE MEASUREMENT

An inlet pressure tap is on the input side of the gas valve.

1. With gas shut off to the furnace at the manual gas valve outside the unit.
2. Loosen (do **NOT** remove) the inlet pressure tap using a 3/32" allen-head wrench (see Figure 37).
3. Connect a manometer to the pressure tap. The pressure tap requires a 5/16" I.D. hose.

A kit is available from Prostock Replacement Parts which includes the following:

- A. 3/32" allen-head wrench
- B. 5/16" to 1/4" I.D. hose reducer fitting
- C. Short piece of 5/16" I.D. hose

Kit part number is: F0092-100300S1

4. Turn on the gas supply and operate the furnace and all other gas-fired units on the same gas line as the furnace.
5. Note or adjust the line gas pressure to give:
  - A. 5" - 10.5" w.c. for natural gas.
  - B. 11" - 13" w.c. for LP gas.
6. Shut off the gas at the manual gas valve and remove the manometer and hose.
7. Tighten the allen-head screw in the inlet pressure tap using a 3/32" allen-head wrench (see Figure 37) and replace the pressure tap plug before turning on the gas.
8. Turn on the gas supply and check for leaks using an approved leak detector. Do **NOT** use a flame of any kind to check for leaks. Repair any leaks and repeat.

If the supply gas line pressure is above these ranges, install an in-line gas regulator to the furnace for natural gas units. With LP gas, have the LP supplier reduce the line pressure at the regulator.

If supply gas line pressure is below these ranges, either remove any restrictions in the gas supply piping or enlarge the gas pipe. See Tables 12 and 13. With LP gas, have the LP supplier adjust the line pressure at the regulator.

### ⚠ CAUTION

**ELEVATIONS ABOVE 2000 FT. REQUIRE THAT THE FURNACE INPUT RATING BE ADJUSTED AND THAT THE SIZE OF THE BURNER ORIFICES BE RECALCULATED BASED ON ELEVATION AND GAS HEATING VALUE. THE BURNER ORIFICES MAY (OR MAY NOT) NEED TO BE CHANGED. SEE THE SECTION TITLED "HIGH ALTITUDE INSTALLATIONS" OF THIS BOOK FOR INSTRUCTIONS.**

**Manifold Gas Pressure Measurement. Natural gas manifold pressure should be 3.5" w.c. for high fire and 1.8" w.c. for low fire. LP gas manifold pressure should be 10.0" w.c. for high fire and 4.9" w.c. for low fire.**

Only small variations in gas pressure should be made by adjusting the pressure regulator.

1. With the gas to the unit shut off at the manual gas valve, remove the outlet pressure tap plug.
2. Loosen (do **NOT** remove) the outlet pressure tap plug using a 3/32" allen-head wrench (see Figure 37).
3. Connect a manometer to the pressure tap. The pressure tap requires a 5/16" I.D. hose.

A kit is available from Prostock Replacement Parts which includes the following:

- A. 3/32" allen-head wrench
- B. 5/16" to 1/4" I.D. hose reducer fitting
- C. Short piece of 5/16" I.D. hose

Kit part number is: F0092-100300S1

4. Turn on the gas supply and operate the furnace (apply a heat call).
5. Note or adjust the manifold gas pressure to give:
  - A. 3.5" w.c. for natural gas.
  - B. 10.0" w.c. for LP gas.
6. To adjust the pressure regulators, remove the regulator caps. (See Figure 37.)
7. Turn the adjustment screw clockwise to increase pressure, or counterclockwise to decrease pressure.
8. Securely replace the regulator caps.
9. Shut off gas at the manual gas valve and remove the manometer and hose.
10. Tighten the allen-head screw in the inlet pressure tap using a 3/32" allen-head wrench (see Figure 37).
11. Turn on the gas supply and apply a heat call to the furnace. Then check for gas leaks using an approved leak detector. Do **NOT** use a flame of any kind to check for leaks. Repair any leaks and repeat.

# ELECTRICAL WIRING

## ELECTRICAL WIRING

### ⚠ WARNING

TURN OFF ELECTRIC POWER AT FUSE BOX OR SERVICE PANEL BEFORE MAKING ANY ELECTRICAL CONNECTIONS. FAILURE TO DO SO CAN CAUSE ELECTRICAL SHOCK RESULTING IN PERSONAL INJURY OR DEATH.

### ⚠ WARNING

THE CABINET MUST HAVE AN UNINTERRUPTED GROUND ACCORDING TO THE LATEST EDITION OF THE NATIONAL ELECTRICAL CODE, ANSI/NFPA70- OR IN CANADA, THE CANADIAN ELECTRICAL CODE, CSA-C221 OR LOCAL CODES THAT APPLY. DO NOT USE GAS PIPING AS AN ELECTRICAL GROUND. A GROUND SCREW IS PROVIDED IN THE JUNCTION BOX. FAILURE TO DO SO CAN CAUSE ELECTRICAL SHOCK RESULTING IN PERSONAL INJURY OR DEATH.

### ⚠ WARNING

THIS FURNACE IS EQUIPPED WITH A BLOWER DOOR SAFETY SWITCH. DO NOT DISABLE THIS SWITCH. FAILURE TO FOLLOW THIS WARNING CAN RESULT IN ELECTRICAL SHOCK, PERSONAL INJURY OR DEATH.

**IMPORTANT:** The furnace must be installed so that the electrical components are protected from water (condensate).

Before proceeding with the electrical connections, be certain that the voltage, frequency and phase corresponds to that specified on the furnace rating plate. For single furnace application, maximum over-current protection is 15 amperes.

Use a separate fused branch electrical circuit containing a properly sized fuse or circuit breaker. Run this circuit directly from the main switch box to an electrical disconnect that is readily accessible and located near the furnace (as required by code). Connect from the electrical disconnect to the junction box on the left side of the furnace, inside the blower compartment. For the proper connection, refer to the appropriate wiring diagram located on the inside cover of the furnace control box and in these instructions.

**NOTE:** The electrical junction box may be moved to the right side if necessary. A knockout is provided. Seal the opposite hole with plug provided.

**NOTE:** L1 (hot) and L2 (neutral) polarity must be observed when making field connections to the furnace. The ignition control may not sense flame if L1 and L2 are reversed. Make all electrical connections in accordance with the latest edition of the National Electrical Code;

ANSI/NFPA70 or, in Canada, The Canadian Electrical Code and local codes having jurisdiction.

These may be obtained from:

National Fire Protection Association, Inc.  
Batterymarch Park  
Quincy, MA 02269

**FIGURE 39**  
DOOR SWITCH REMOVAL INSTRUCTIONS

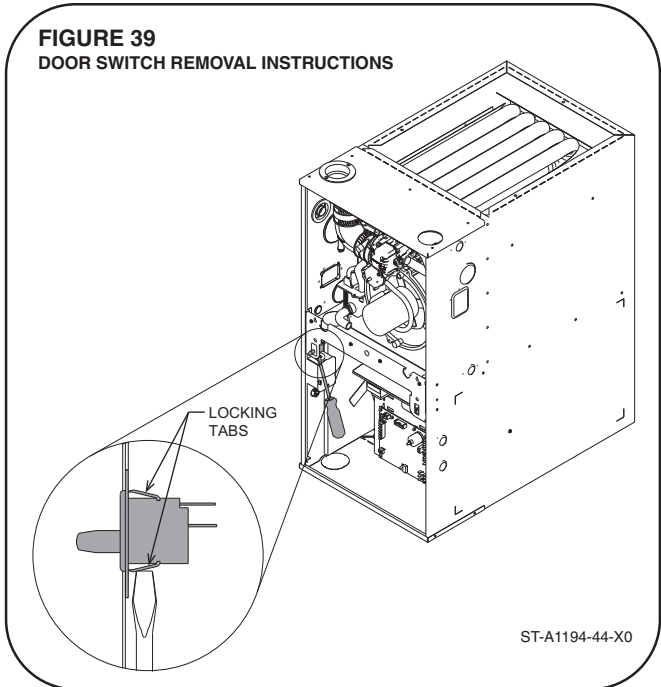

CSA - International  
5060 Spectrum Way  
Mississauga, Ontario  
Canada L4W 5N6  
online: [www.csa.ca](http://www.csa.ca)

## REVERSING THE ELECTRICAL CONNECTION (JUNCTION BOX)

If the line voltage electrical needs to be moved to the opposite side of the furnace, the following steps should be taken:

1. The furnace must NOT be electrically connected to line voltage prior to reversing the electrical connection.
2. Disconnect the wires from the door switch.
3. Remove the junction box from the furnace cabinet wall by removing the two screws that hold it to the cabinet. Leave the wires connected to the junction box.
4. Remove 7/8" plug from hole opposite j-box location. Drill 2 @ 3/16" Ø holes in the jacket. **NOTE:** Dimples/marks are provided in the sheet metal for correct drilling location.

# ELECTRICAL WIRING

## REVERSING ELECTRICAL CONNECTION & THERMOSTAT

5. Move the junction box to the opposite side of the cabinet. Install using the two screws removed in step 3 above. Note that all screws penetrating the junction box must be blunt – no sharp tipped screws can be used.
6. Replace the plug from the opposite of the furnace (the new j-box location) to the old j-box location and install qty=2 1/4" plugs from parts bag in empty screw holes in old location of j-box into the mounting screw holes in the old junction box location.
7. Using a flat screwdriver, squeeze the retaining arms on the door switch and gently pry the door switch from its opening as shown in Figure 39.
8. Install the door switch in the same opening on the opposite of the furnace and reconnect the electrical connectors (removed in Step 2) to the door switch.

**NOTE:** Do not use 24 volt control wiring smaller than No. 18 AWG.

Install the room thermostat in accordance with the instruction sheet packed in the box with the thermostat. Run the thermostat lead wires inside the blower compartment and connect to low voltage terminals as shown on the wiring diagram. Never install the thermostat on an outside wall or where it will be influenced by drafts, concealed hot or cold water pipes or ducts, lighting fixtures, radiation from fire-place, sun rays, lamps, televisions, radios or air streams from registers.

## THERMOSTAT

The room thermostat must be compatible with the furnace. See manufacturer's thermostat spec sheet for compatibility concerns. Generally, all thermostats that are not of the "current robbing" type are compatible with the integrated furnace control. The low voltage wiring should be sized as shown.

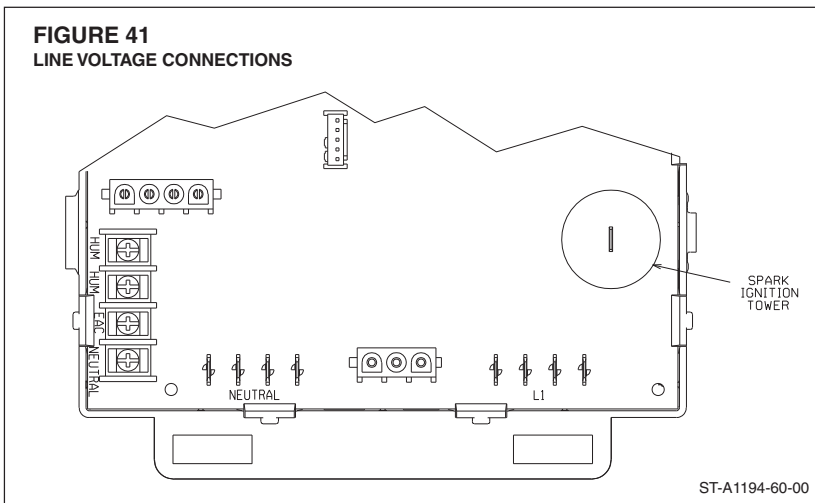
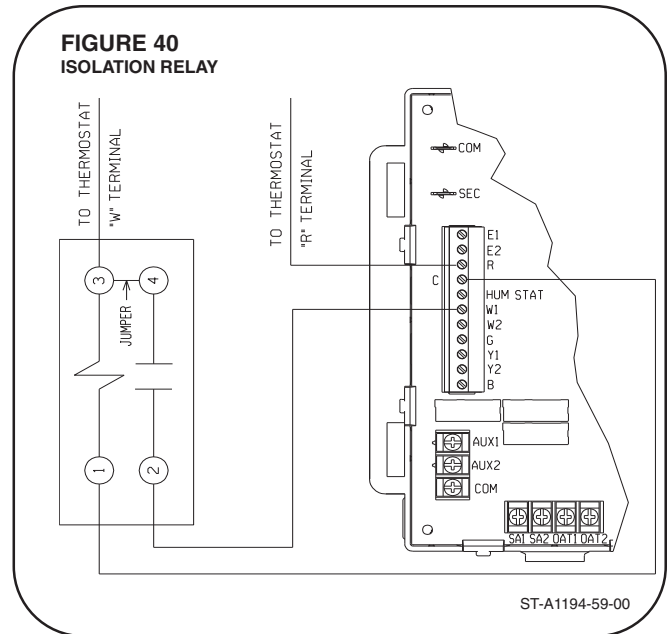

# ACCESSORIES

## FIELD INSTALLED OPTION ACCESSORIES

### ELECTRONIC AIR CLEANER

Line voltage power can be supplied from the terminal labeled “EAC” and a line voltage neutral terminal on the control board. This will power the electronic air cleaner whenever the circulating air blower is in operation.

**NOTE:** The electronic air cleaner output will not be energized when the ECM blower motor target CFM is below the following thresholds:

- (-)96V060 = 500 CFM
- (-)96V070 = 500 CFM
- (-)96V085 = 600 CFM
- (-)96V100 = 600 CFM

Under some circumstances, such as low-speed continuous fan, the target blower CFM may be below the above threshold. In these cases the electronic air cleaner output will NOT be energized.

**NOTE:** Maximum current is 1.0 amps for the electronic air cleaner output.

### HUMIDIFIER

Humidifier output is a set of dry contacts. The logic controlling these contacts and the necessary wire diagrams for installing a humidifier are detailed in the section of this manual titled *Humidification/Dehumidification*.

### FILTERS (See Figure 42)

Keep filters clean at all times. **A filter is not provided with the furnace, but one must be field-supplied and installed.**

It is recommended to replace the furnace filter periodically to maintain optimum furnace performance.

### TWINNING

Twinning of these furnaces is NOT permitted!

# ACCESSORIES

## FIELD INSTALLED OPTION ACCESSORIES (cont.)

**FIGURE 42**  
FILTER LOCATIONS

### UPFLOW/HORIZONTAL

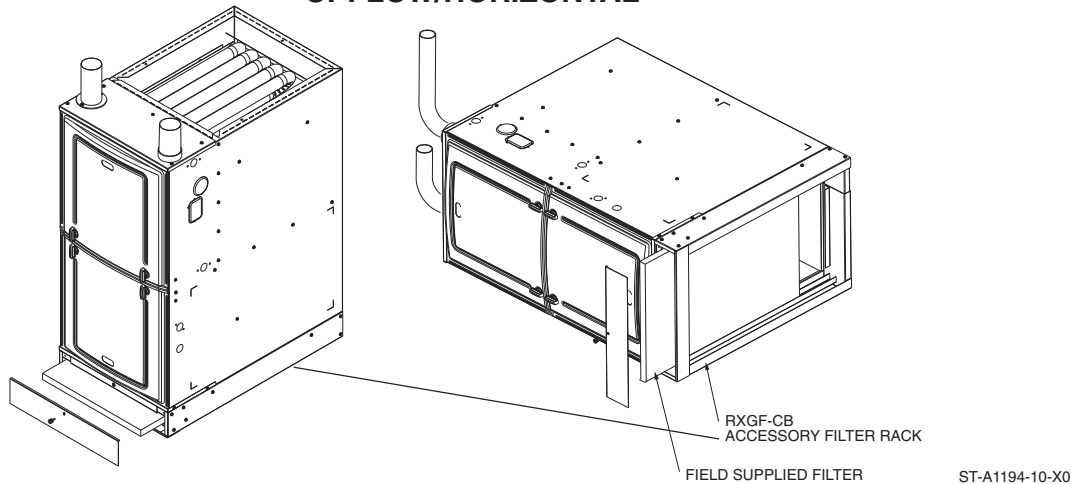

### SIDE RETURN

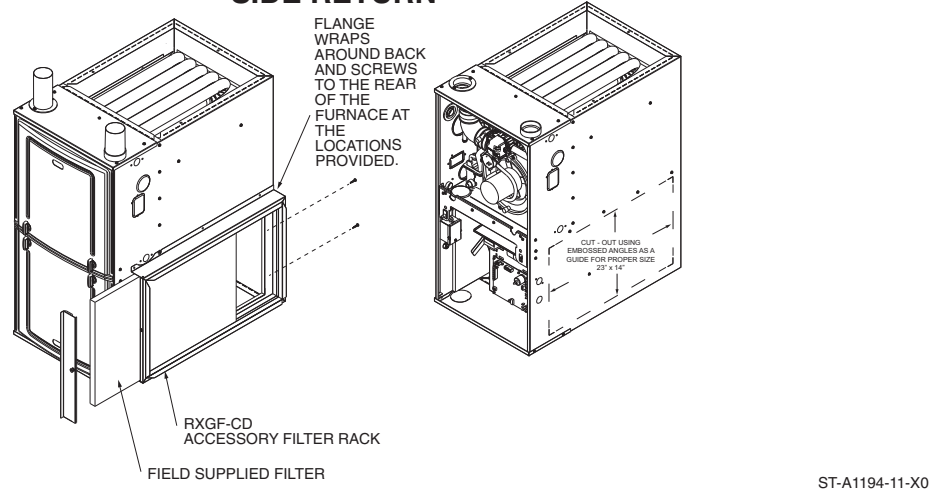

### HORIZONTAL/DOWNFLOW

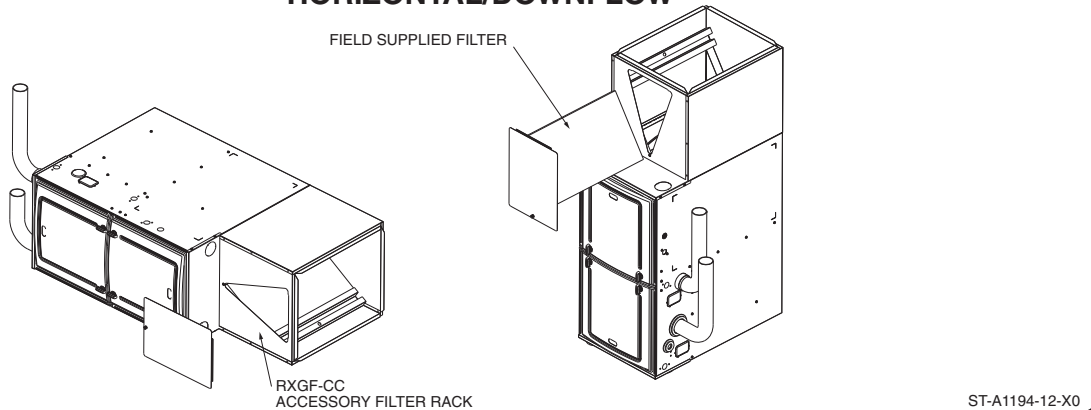

# HIGH ALTITUDE

## NATURAL GAS AT HIGH ALTITUDES

No high altitude pressure switch changes are required; only a 4% derate at altitudes above 2,000 feet.

### NATURAL GAS

#### CAUTION

INSTALLATION OF THIS FURNACE AT ALTITUDES ABOVE 2000 FT. (610 M) SHALL BE IN ACCORDANCE WITH LOCAL CODES, OR IN THE ABSENCE OF LOCAL CODES, THE NATIONAL FUEL GAS CODE, ANSI Z223.1/NFPA 54 OR IN CANADA, NATURAL GAS AND PROPANE INSTALLATION CODE, CSA B149.1.

#### CAUTION

ELEVATIONS ABOVE 2000 FT. REQUIRE THAT THE FURNACE INPUT RATING BE ADJUSTED AND THAT THE SIZE OF THE BURNER ORIFICES BE RE-CALCULATED BASED ON ELEVATION AND GAS HEATING VALUE. THE BURNER ORIFICES MAY (OR MAY NOT) NEED TO BE CHANGED. THE FOLLOWING EXAMPLES SHOW HOW TO DETERMINE IF AN ORIFICE CHANGE WILL BE NECESSARY AND HOW TO DETERMINE THE NEW ORIFICE SIZE.

IN CANADA, AS AN ALTERNATE TO ADJUSTING THE BURNER ORIFICE SIZE, THE MANIFOLD GAS PRESSURE MAY BE ADJUSTED. THIS METHOD IS COVERED LATER IN THIS SECTION. THIS METHOD OF ADJUSTING MANIFOLD PRESSURE MAY ONLY BE USED IN CANADIAN INSTALLATIONS.

**NOTE:** Factory installed orifices are calculated and sized based on a sea level Natural Gas heating value of 1100 BTU per cubic ft. Regional reduced heating values may nullify the need to change orifices except at extreme altitudes.

The following are examples of orifice sizing using the National Fuel Gas Code Annex E, tables E.1.1(a) and E.1.1(d). For a simplified estimation of orifice size based on heating value and elevation, use Table 13. However, calculations are the best method.

#### **Example: 900 BTU/ft<sup>3</sup> Regional Natural Gas Heating Value**

$$I / H = Q$$

$$14000 / 900 = 15.56 \text{ ft.}^3$$

I = Sea Level input (per burner): 14000

H = Sea Level Heating Value: 900

Q = 15.56 ft<sup>3</sup> Natural Gas per hour.

From Table E.1.1(a) of *National Fuel Gas Code Handbook*, current edition (3.5" w.c. column)

Orifice required at Sea Level: #49

From Table E.1.1(d) of *National Fuel Gas Code Handbook*, current edition

Orifice required at 5000 ft. elevation (4% de-rate per thousand ft.): #51

Orifice required at 8000 ft. elevation (4% de-rate per thousand ft.): #52

# HIGH ALTITUDE

## NATURAL GAS AT HIGH ALTITUDES (cont.)

**TABLE 14**

### NATURAL GAS ORIFICE SELECTION BASED ON HEATING VALUE & ELEVATION\*

Notes:

1. All R92,R95 single stage and R96 two stage units are factory equipped with orifices sized for 1100 sea level heating value gas.
2. Local utilities adjust the sea level heating value of gasses used at higher elevations to compensate for appliance operation at altitude. Installer must be aware of the local heating value (sea level standard) to use the chart below.
3. This chart is based on the National Fuel Gas Code (NFGC) Annex F based on natural gas with a secific gravity of 0.60
4. The recommended orifices below allow the furnace to operate within 10% of design rate. However, NFGC calculations are the best method.
5. Furnace operation is optimized when operating at design rate. Installer is responsible to verify rate.
6. This table applies to 90+ models only with 14,000BTU/Burner. DO **NOT** USE THIS CHART FOR ANY 80+ FURNACE MODEL.

Grey Cells Indicate Factory Orifice Size	Sea Level to 1,999'	ELEVATION									
		2,000' to 2,999'	3,000' to 3,999'	4,000' to 4,999'	5,000' to 5,999'	6,000' to 6,999'	7,000' to 7,999'	8,000' to 8,999'	9,000' to 9,999'	10,000'	
Gas Heating Value (BTU's/ft') @ Sea Level**	1,000-1,100	52	52	53	53	53	53	53	54	54	54
		51	51	52	52	52	52	53	53	53	54
		50	51	51	51	51	52	52	52	53	53
	900-999	51	51	52	52	52	52	53	53	53	54
		50	51	51	51	51	52	52	52	53	53
		49	50	50	50	51	51	51	52	52	52
	800-899	50	51	51	51	51	52	52	52	53	53
		49	50	50	50	51	51	51	52	52	52
		48	49	49	49	50	50	50	51	51	52
	700-799	48	49	49	49	50	50	50	51	51	52
		47	48	48	49	49	49	50	50	51	51
		46	47	47	47	48	48	49	49	50	50
45		46	47	47	47	48	48	49	49	50	

\*Table is derived from Appendix of the *National Fuel Gas Code*. To determine the correct orifice for your installation consult the *National Fuel Gas Code* tables F.1 and F.4

\*\*Be sure to use sea level heating value. When requesting the heating value from a local utility, it must be converted to sea level equivalent in order to use this table.

**Note:** Above 5,000ft, the last 2 elbows on an alternate horizontal termination which are on the exterior of the building will be counted in the maximum vent length and maximum number of elbows permitted.

# HIGH ALTITUDE

## LP GAS AT HIGH ALTITUDES

### ORIFICE INSTALLATION

LP Gas is a manufactured gas that has consistent heating value across most regions.

The NFGC guidelines are used with the following exception:

The recommended LP Gas high altitude orifice selections differ slightly in that the NFGC LP orifice chart, as they are not accurate for this furnace product. The National Fuel Gas Code LP orifices are based on an 11" of water column pressure at the orifice, which differs from this furnace product that use 10" of water column at the orifice. This difference requires a deviation from the NFGC orifice size recommendations. The Sea Level input should still be reduced by 4% per thousand ft. and the orifice size must be selected based on the reduced input selection Table 15.

### ORIFICE ORDERING INFORMATION

Orifice sizes are selected by adding the 2-digit drill size required in the orifice part number. Drill sizes available are 39 through 64; metric sizes available 1.10mm (-90):

Orifice Part Number 62-22175-(drill size)

Example 1:

# 60 drill size orifice required  
Part # 62-22175-60

Example 2:

1.10 mm drill size orifice required  
Part # 62-22175-90

### ALTERNATE METHOD OF CANADIAN HIGH-ALTITUDE DERATE

In Canada, unless an orifice change is specifically mandated by local codes, an alternate method of altitude deration through a reduction in manifold pressure is acceptable as described in Table 16.

The information in Table 16 is based on a heating value of 1000 BTU per cubic feet of natural gas, and 2500 BTU per cubic feet of LP gas.

**IMPORTANT:** Actual input rates must be measured on-site with manifold pressure adjustment to ensure that an actual 10% reduction in input rate is achieved.

Once this field adjustment has been made, the label shown in Figure 43 must be affixed in a conspicuous location on the front of the furnace cabinet:

**NOTE:** This label is supplied in the information packet shipped with each furnace.

**TABLE 15**  
LP GAS ORIFICE DRILL SIZE  
(4% PER 1000 FT DE-RATE)  
IMPORTANT: 90 Plus Models only.

Altitude	Input (per burner) 14000	Orifice Size
0 to 2000 ft.	14,000	1.10 mm (factory kit)
2000'-3000'	12,320	#58
3000'-4000'	11,760	#59
4000'-5000'	11,200	#59
5000'-6000'	10,640	#60
6000'-7000'	10,080	#60
7000'-8000'	9,520	#61
8000'-9000'	8,960	#62
9000'-10000'	8400	#63

**TABLE 16**  
ALTERNATE METHOD FOR CANADIAN HIGH-ALTITUDE DERATE  
IMPORTANT: 90 Plus Models only.

NATURAL GAS					LP GAS				
ALTITUDE	INPUT	OUTPUT	ORIFICE SIZE	MANIFOLD PRESSURE	ALTITUDE	INPUT	OUTPUT	ORIFICE SIZE	MANIFOLD PRESSURE
0' - 2000'	42,000	39,900	#51	3.5" W.C.	0' - 2000'	42,000	39,900	1.15mm	10" W.C.
	56,000	53,200				56,000	53,200		
	70,000	66,500				70,000	66,500		
	84,000	79,800				84,000	79,800		
	98,000	93,100				98,000	93,100		
112,000	106,400	112,000	106,400						
2001' - 4500'	37,800	35,910	#51	3.0" W.C.	2001' - 4500'	37,800	35,910	1.15mm	7.6" W.C.
	50,400	47,880				50,400	47,880		
	63,000	59,850				63,000	59,850		
	75,600	71,820				75,600	71,820		
	88,200	83,790				88,200	83,790		
100,800	95,760	100,800	95,760						

**FIGURE 43**  
MANIFOLD PRESSURE-CHANGE LABEL

THE MANIFOLD PRESSURE OF THIS APPLIANCE HAS BEEN FIELD ADJUSTED TO OBTAIN THE CORRECT INPUT RATING FOR INSTALLATION AT ALTITUDES BETWEEN 2,000 FEET AND 4,500 FEET ELEVATION.

LA PRESSION DU DISTRIBUTEUR D'ALIMENTATION DE CET APPAREIL A ÉTÉ AJUSTÉ SUR LES LIEUX AFIN D'OBTENIR LA BONNE PUISSANCE D'ENTRÉE POUR UNE INSTALLATION ENTRE 2000 ET 4500 PIEDS D'ALTITUDE.

92-24399-01-01

# COMMUNICATING FURNACE CONTROL

## START-UP AND SEQUENCE OF OPERATIONS

This furnace is equipped with a direct ignition control. Each time the room thermostat calls for heat, the ignitor lights the main burners directly. See the lighting instructions on the furnace.

### TO START THE FURNACE

1. Remove the burner compartment control access door.
2. **IMPORTANT:** Be sure that the manual gas control has been in the "OFF" position for at least five minutes. Do not attempt to manually light the main burners.
3. Turn off the furnace electrical power and set the room thermostat to its lowest setting.
4. Turn the gas control to the "ON" position or move the gas control lever to the "On" position.
5. Replace the burner compartment control access door.
6. Turn on the furnace electrical power.
7. Set the room thermostat to a point above room temperature to light the main burners. The heat call should be adequate to activate the high stage gas heat – generally, the thermostat setpoint should be more than 2°F above room temperature. Consult your thermostat specs to be sure.
8. Operate high gas heat for a minimum period of 15 minutes and adjust input rate (See Section of this book titled *Adjusting Input Rate*) and observe condensate system for leaks. Correct leaks and set rate, shut down furnace and repeat until no leaks in condensate system can be detected.
9. Once high heat operation has been successfully verified and rate adjusted, the thermostat should be adjusted to set the heat call to low stage. This is generally with the heating setpoint at about 1°F above room temperature. Consult your thermostat specs to be sure.
10. Operate low gas heat for a minimum period of 15 minutes and adjust input rate (page 88) and observe condensate system for leaks. Correct leaks and set rate, shut down furnace and repeat until no leaks in condensate system can be detected.

### TO SHUT DOWN THE FURNACE

1. Set the room thermostat to its lowest setting and wait for furnace to shut down.
2. Remove the burner compartment control access door.
3. Shut off the gas to the main burners by turning the gas control to the "OFF" position.

### SEQUENCE OF OPERATION

#### HONEYWELL CONTROLS Integrated Controls with Direct Spark Ignition.

1. Each time the thermostat "W" (Heating) contacts close (legacy) or a communicating heat call is transmitted to

### WARNING

**SHOULD OVERHEATING OCCUR OR THE GAS SUPPLY FAIL TO SHUT OFF, CLOSE THE MANUAL GAS VALVE FOR THE APPLIANCE BEFORE SHUTTING OFF THE ELECTRICAL SUPPLY. FAILURE TO DO SO CAN CAUSE AN EXPLOSION OR FIRE RESULTING IN PROPERTY DAMAGE, PERSONAL INJURY OR DEATH.**

- the furnace control from a communicating thermostat, the furnace control checks to make sure that both pressure switches are open. This is true of a low or high heat call as "W" is energized on either call. Next the induced draft blower (inducer) begins a pre-purge cycle at high stage.
2. The air proving negative pressure switches (both low and high) close.
3. After the 30-second pre-purge, **the gas valve opens on high stage for an 8-second trial for ignition.**
4. The spark igniter is energized to light the gas burners and **stays energized for the up to 7 seconds after the gas valve opens.**
5. Eight seconds after the gas valve opens **the remote flame sensor must prove flame ignition for one second** using the process of flame rectification. If the burners don't light, the system goes through another ignition sequence. It does this **up to four** times before entering a 1-hour lockout.
6. Twenty seconds after flame is sensed, the gas valve is set to the thermostat demand (low or high) (note if thermostat demand is high, the gas valve is already at high stage and will not switch) and the main blower will be energized at either the low or high gas heat stage depending on the thermostat demand.
7. When the thermostat "W" (legacy) or communicated heat call ends, the gas valve closes, flame is extinguished, the induced draft blower stops after a **10-second post-purge**, and the negative pressure switch opens.
8. The main blower continues until timed off by the setting on the integrated furnace control board.

#### Sequence if the system doesn't light or doesn't sense flame:

1. Each time the thermostat "W" (Heating) contacts close, the furnace control checks to make sure that both pressure switches are open. This is true of a low or high heat call as "W" is energized on either call. Next the induced draft blower (inducer) begins a pre-purge cycle at high stage.
2. After the 30-second pre-purge, **the gas valve opens on high stage for an 8-second trial for ignition.**

# INTEGRATED FURNACE CONTROL

**FIGURE 44**  
R96V TWO-STAGE COMMUNICATING FURNACE CONTROL LAYOUT

ST-A1194-51

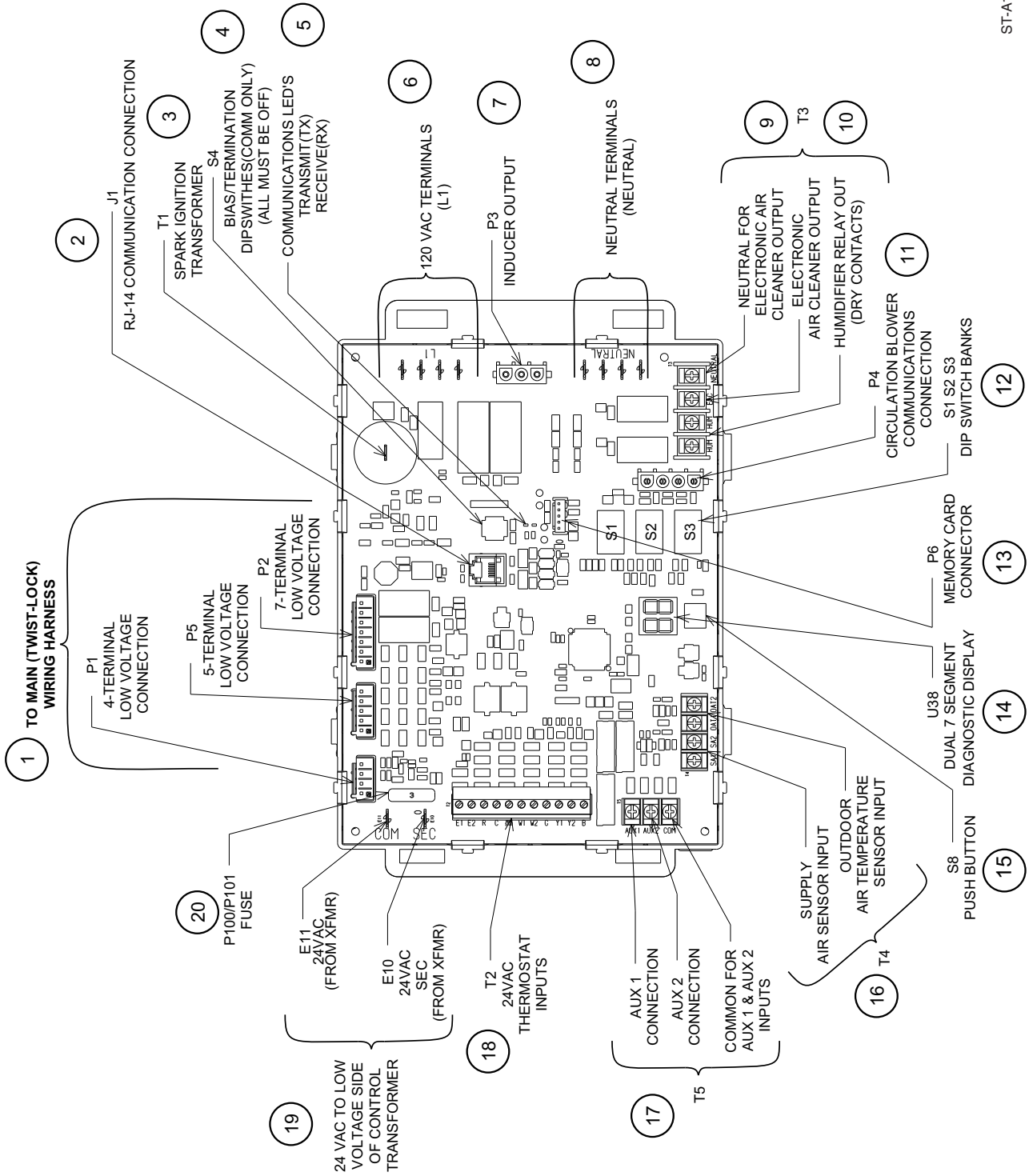

# INTEGRATED FURNACE CONTROL

- P1 (4-Pin), P2 (7-Pin) and P5 (5-Pin) - Low-Voltage Internal Wiring Connections** – Connect main twist-lock wire harness to these connections. Pre-wired from the factory.
- RJ-14 CONNECTOR (J1)**

## **⚠ WARNING**

**DO NOT CONNECT A TELEPHONE OR PHONE LINE TO THE CONNECTOR (JACK) AT POSITION J-11. DOING SO COULD CAUSE IRREPARABLE DAMAGE TO EITHER THE FURNACE CONTROL (I.F.C.) OR THE TELEPHONE (OR TELEPHONE LINE) OR BOTH.**

This connector is used to program the furnace control at the factory. It should never be connected to a telephone line or a telephone. Doing so could damage the furnace control or the telephone (or telephone lines) or both.

- SPARK IGNITION TRANSFORMER (T1)**  
The spark ignition transformer resides on the furnace control. The transformer provides spark energy at approximately 60 hz frequency and a minimum of 12KV.
- BIAS / TERMINATION (S4)**  
For current installations, all three of the dip-switches in bank SW4 must be in the “OFF” position. If not, the system may not be able to communicate.
- COMMUNICATIONS LED’S (U38)**  
Two LED’s are provided to indicate the status of communications. A red LED (Labeled TX) is provided for transmit and a green LED (Labeled RX) is provided for receive. These LED’s will be lit in an undefined pattern when other communicating components are attached and communicating with the furnace control.
- LINE VOLTAGE CONNECTIONS (120VAC, L1)**  
Four ¼” Quick-Connect style terminals are provided for internal connections and accessories.
- INDUCED DRAFT MOTOR (INDUCER) OUTPUT (P3)**  
This three-pin Mate-n-Lok style connector provides power to both the high and low speed inducer outputs.
- NEUTRAL TERMINALS (N)**  
Four ¼” Quick-Connect style terminals are provided for internal connections and accessories.
- ELECTRONIC AIR CLEANER (E.A.C.) OUTPUT (T3)**  
This output is used to energize an electronic air cleaner. The output will provide 1.0 amp at 115 VAC. This output is energized any time the blower motor is above the airflow CFM values specified below. Airflow below this value is not considered to be enough for a typical electronic air cleaner to perform properly.

For ½ HP motors - Electronic air cleaner is energized any time the blower is above 500 CFM

For ¾ HP motors - Electronic air cleaner is energized any time the blower is above 600 CFM

For 1 HP motors - Electronic air cleaner is energized any time the blower is above 700 CFM

Continuous fan speeds are selectable and some lower fan speeds may not deliver enough airflow to operate an electronic air cleaner. The IFC determines the minimum airflow necessary to operate an electronic air cleaner and will not turn on the electronic air cleaner unless the airflow is high enough for the EAC.

**FIGURE 45**  
ELECTRONIC AIR CLEANER AND HUMIDIFIER TERMINALS

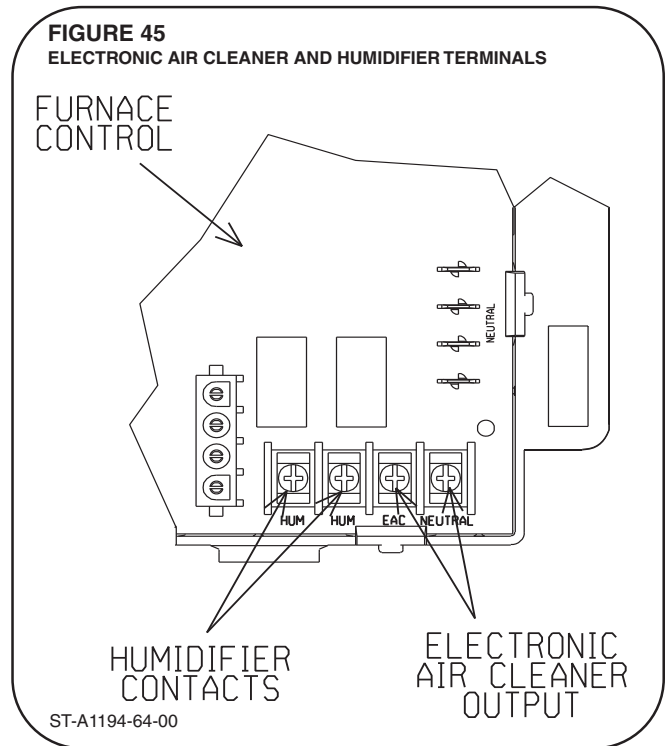

- HUMIDIFICATION (T3) AND DEHUMIDIFICATION HUMIDIFIER** – The humidifier contacts (labeled “HUM” (2)) are “dry” contacts on the I.F.C. This means that the terminals are connected directly to the contacts of a board-mounted relay. The coil of the relay is controlled by the microprocessor of the IFC. The coil is engaged roughly any time the heat speed blower is engaged and (1) 24VAC is present on the thermostat terminal of the IFC labeled “HUM STAT” or (2) a communicating thermostat with humidification and dehumidification capability is installed with call for humidification present. (See Figure 45 for location of humidification/dehumidification inputs on furnace control.)

# INTEGRATED FURNACE CONTROL

## HUMIDIFICATION/DEHUMIDIFICATION

An optional 24VAC humidistat can be installed as shown in Figures 46 thru 49. With the optional humidistat, two separate conditions must be met before humidification can begin 1.) There must be a call for heat and the blower must be engaged and 2.) The humidistat must determine that there is a need for humidification. Note: Dipswitch S2-8 (labeled “ODD”) enables (“ON”) or disables (“OFF”) de-humidification operation. However, it has no effect on humidification operation. If this switch is set to the “ON” position and no humidistat is installed, the cooling airflow will be permanently reduced by approximately 15% giving less than optimal performance and possibly causing problems. It is not recommended to leave this switch in the “ON” position without a humidistat installed.

Control of dehumidification in cooling and/or humidification in heating can be done with a variety of methods depending on whether there is a communicating thermostat or a humidistat available and depending on the type of operation desired.

With systems configured with communicating thermostats and condensers, dehumidification is controlled by the thermostat and is not affected by the position of dipswitch SW2-1 or the voltage at the thermostat input T2 labeled “HUM STAT” on the furnace. To determine which wiring diagram and method to use, select from the following configurations:

### A. HUMIDIFICATION CONTROL ONLY WITH NO DEHUMIDIFICATION (REQUIRES OPTIONAL HUMIDIFIER).

#### A1. WITH COMMUNICATING THERMOSTAT

Humidifier control is included with EcoNet communicating thermostats. To wire the furnace for humidification control using an EcoNet communicating thermostat, refer to the wiring diagram in Figure 46. Be sure not to install the jumper between “R” and “HUM STAT” on the furnace control. Installing this jumper will operate the humidifier any time there is a heat call. Without the jumper, the humidification call from the thermostat must be active and a heat call must be present with the blower running.

#### A2. WITH NON-COMMUNICATING THERMOSTAT

##### A2-1 CONTINUOUS HUMIDIFIER OPERATION DURING HEATING.

For continuous humidifier operation during heating, refer to Figure 46 and make sure to install the jumper between the thermostat terminals labeled “R” and “HUM STAT”. A separate humidistat is not required for this configuration and the humidifier will turn on whenever there is a call for heat and the blower is running.

##### A2-2 CONTROLLED HUMIDIFIER OPERATION USING A HUMIDISTAT (REQUIRES OPTIONAL HUMIDISTAT).

Controlled humidification can be accomplished using a humidistat as shown in Figures 47 or 48. These figures show installation of a humidifier with external and internal power supplies respectively. Dehumidification operation will be disabled if the dipswitch S2-8 is in the “OFF” position. If this switch is in the “ON” position, dehumidification control will be active.

### B. DEHUMIDIFICATION CONTROL WITH NO HUMIDIFICATION

#### B1. WITH COMMUNICATING THERMOSTAT

For communicating thermostats listed with this furnace, dehumidification is controlled automatically when selected at the thermostat and additional wiring is not necessary. The actual airflow demand (reduced for dehumidification) is requested of the furnace by the thermostat.

#### B2. WITH NON-COMMUNICATING THERMOSTAT (REQUIRES OPTIONAL HUMIDISTAT)

Control of dehumidification only (no humidification) can be accomplished by installing an optional humidistat as shown in Figure 49. The dipswitch S2-8 must be set to the “ON” position. If this switch is not turned “ON”, dehumidification operation will not take place. Further, if this switch is “ON” and no humidistat is installed, airflow in cooling will be permanently reduced by approximately 15%.

### C. HUMIDIFICATION AND DE-HUMIDIFICATION CONTROL (REQUIRES OPTIONAL HUMIDIFIER).

#### C1. WITH COMMUNICATING THERMOSTAT

Humidifier control is included with EcoNet communicating thermostats. To wire the furnace for humidification and dehumidification control using an EcoNet communicating thermostat, refer to the wiring diagram in Figure 46. Be sure not to install the jumper between “R” and “HUM STAT” on the furnace control. Installing this jumper will operate the humidifier any time there is a heat call and dehumidification will never take place when in cooling. Without the jumper, a humidification call from the thermostat must be active and a heat call must be present with the blower running for the “HUM” relay contacts to close.

# INTEGRATED FURNACE CONTROL

## HUMIDIFICATION/DEHUMIDIFICATION

### C2. WITH NON-COMMUNICATING THERMOSTAT (REQUIRES OPTIONAL HUMIDISTAT)

For non-communicating thermostats, an optional humidistat must be installed. Controlled humidification and dehumidification can be accomplished using a humidistat as shown in

Figures 47 or 48. These figures show installation of a humidifier with external and internal power supplies respectively. Dehumidification operation will be disabled if the dipswitch S2-8 is in the "OFF" position. If this switch is in the "ON" position, dehumidification control will be active.

**FIGURE 46**  
WIRING FOR OPTIONAL HUMIDIFICATION (AND DE-HUMIDIFICATION WITH COMMUNICATING THERMOSTAT) WITH OPTIONAL HUMIDIFIER AND NO HUMIDISTAT (HUMIDIFICATION ACTIVE DURING ANY HEAT CALL) (FOR USE WITH COMMUNICATING OR NON-COMMUNICATING THERMOSTATS)

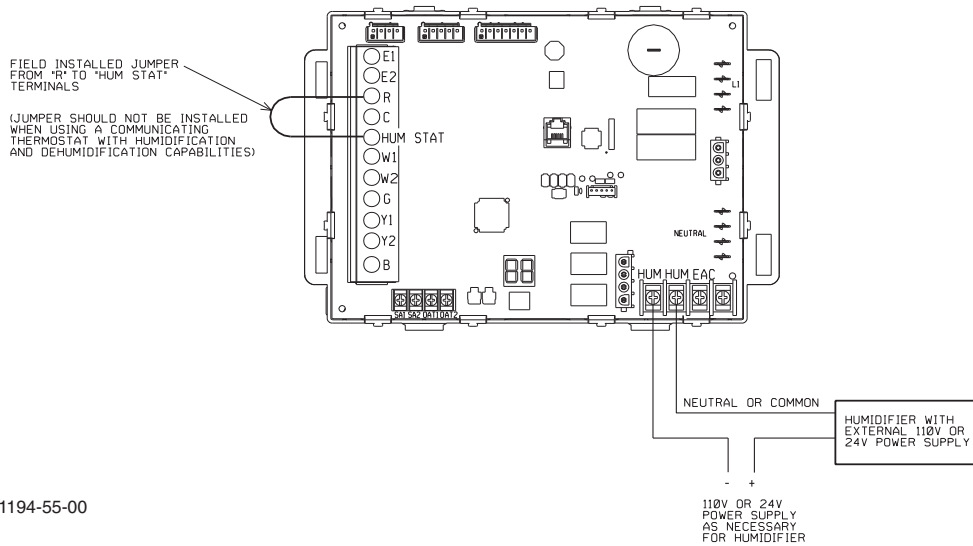

**FIGURE 47**  
WIRING FOR OPTIONAL DE-HUMIDIFICATION AND HUMIDIFICATION (WITH OPTIONAL HUMIDISTAT AND HUMIDIFIER).  
NOTE: CAN BE USED WITH COMMUNICATING OR NON-COMMUNICATING SYSTEMS.

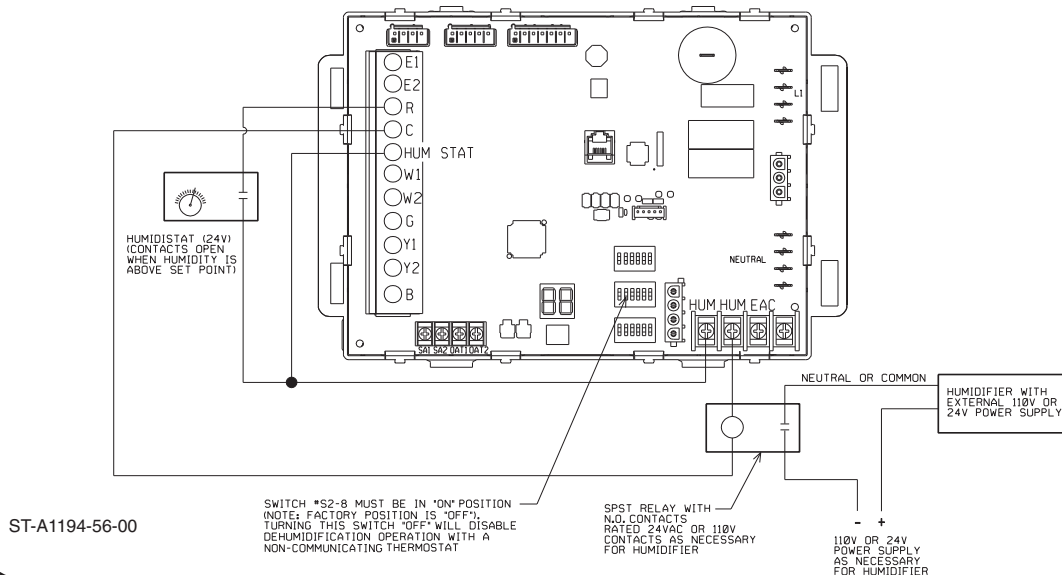

# INTEGRATED FURNACE CONTROL

## HUMIDIFICATION/DEHUMIDIFICATION

**FIGURE 48**  
**WIRING FOR OPTIONAL DE-HUMIDIFICATION AND HUMIDIFICATION WITH OPTIONAL HUMIDIFIER (HUMIDIFIER WITH INTERNAL POWER SUPPLY). NOTE: FOR USE WITH NON-COMMUNICATING SYSTEMS.**

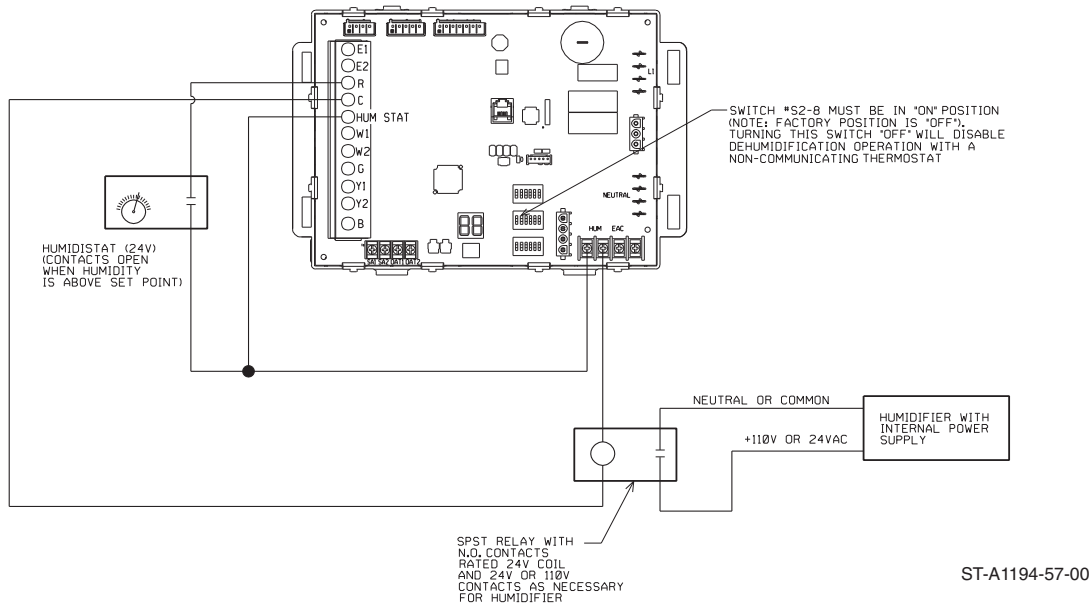

**FIGURE 49**  
**HUMIDISTAT USED TO CONTROL DEHUMIDIFICATION IN COOLING ONLY (NO HUMIDIFIER)**  
**NOTE: FOR USE WITH NON-COMMUNICATING THERMOSTATS.**

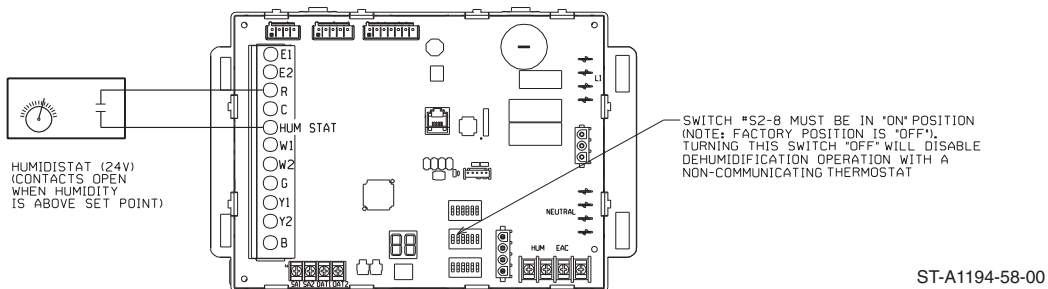

### 11. COMMUNICATING ECM MOTOR COMMUNICATIONS (CONTROL) CONNECTION (P4)

This connector sends and receives messages to and from the blower motor through a single peer-to-peer network. The blower motor does not communicate on the same communications buss as the furnace, condenser (or heat-pump) and thermostat. Further, a different communications protocol is used.

### 12. DIPSWITCHES; S1, S2 AND S3

#### NOTES:

1. There is a protective cover over the dipswitches that must be penetrated to change the dipswitch position. Use a pen or similar tool to penetrate the cover and change the position. This is normal and penetration of the protective cover will not damage the dipswitch.

# INTEGRATED FURNACE CONTROL DIPSWITCHES

**FIGURE 50**  
DIPSWITCH MAP

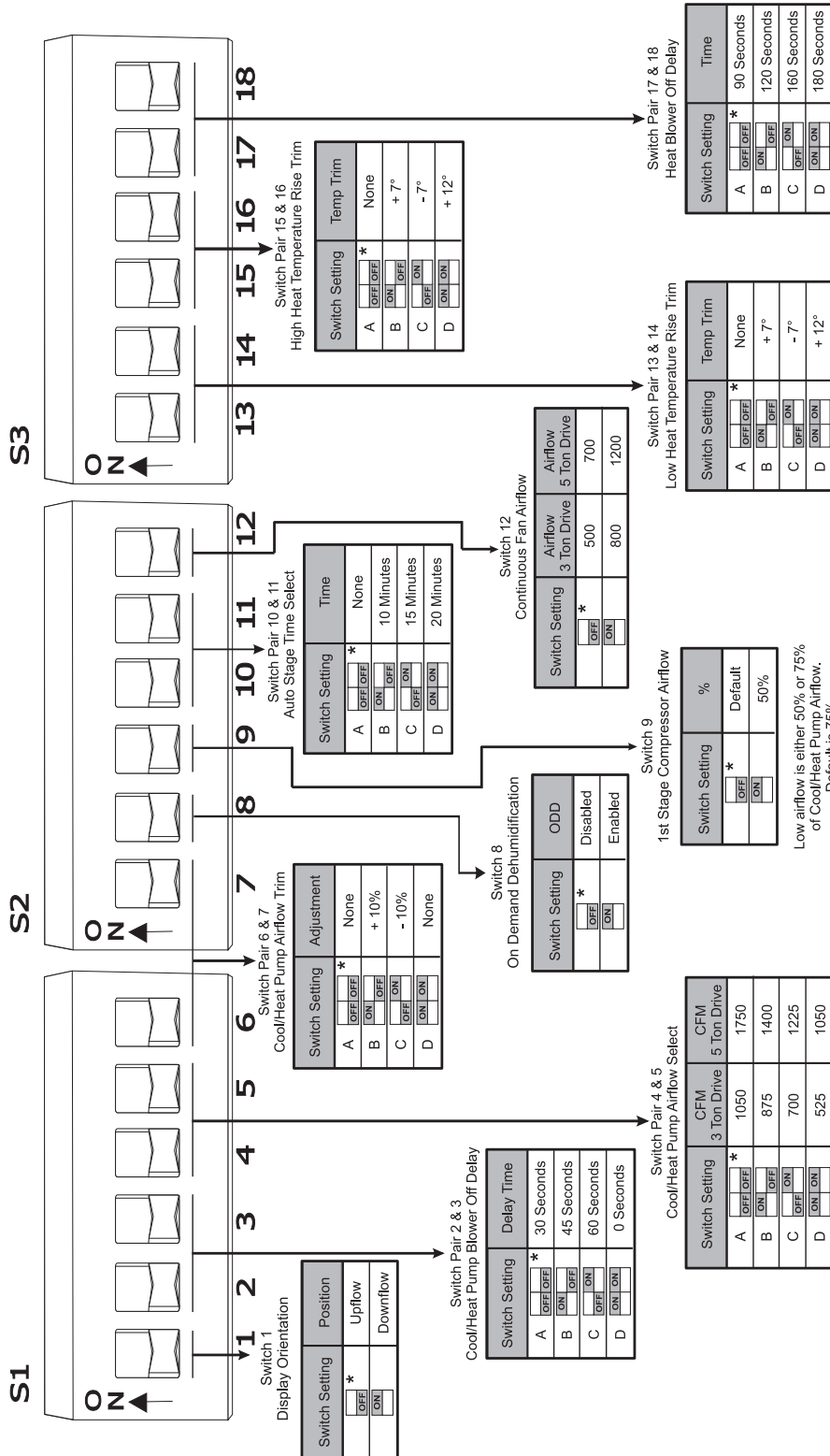

\*Factory Setting (Note: Drawing shows DIP switches in their factory default position.)

ST-A1210-03

# INTEGRATED FURNACE CONTROL

## DIPSWITCHES

2. For communicating systems, dipswitches are not used. Configuration changes are made with the thermostat.

### A. Seven-Segment Display Orientation; S1-1

As the control will be applied in a multi-position furnace a means of changing the orientation of the seven segment display is provided. This dipswitch is to be labeled S1-1. Factory setting of the S1-1 dipswitch is OFF.

S1-1 = OFF = Upflow (as-shipped) position

S1-1 = ON = Downflow position

### B. Cool Blower-Off Delay; S1-2 & S1-3

A means of selecting the cooling speed blower "off" delay time is provided. In legacy mode, dipswitches are required to select the delay time. These dipswitches are to be labeled S1-2 and S1-3. The following table defines the settings:

S1-2	SW3	Selection
OFF	OFF	30 seconds
Note: Factory setting = 30 seconds		
ON	OFF	45 seconds
OFF	ON	60 seconds
ON	ON	0 seconds

### C. Cooling Airflow Selection; S1-4 & S1-5

S1-4 and S1-5 are to be used to select cooling airflow in legacy mode. The value used for each selection is specified below.

#### HIGH COOL SELECTIONS:

S1-4	S1-5	½ HP Blower (56 & 70KBTU)	¾ HP Blower (84 & 98KBTU)
OFF	OFF	1050 CFM	1750 CFM (Factory Setting)
ON	OFF	875 CFM	1400 CFM
OFF	ON	700 CFM	1225 CFM
ON	ON	525 CFM	1050 CFM

#### LOW COOL SELECTIONS:

The following model data fields are multipliers to be used for low stage legacy cooling unless dipswitch S2-9 is in the ON position - in which case the low cooling airflow becomes 50% of the high cooling airflow.

S1-4	S1-5	½ HP Blower (56 & 70KBTU)	¾ HP Blower (84 & 98KBTU)
OFF	OFF	788 CFM	1313 CFM (Factory Setting)
ON	OFF	656 CFM	1050 CFM
OFF	ON	525 CFM	919 CFM
ON	ON	394 CFM	788 CFM

Airflow dipswitches are to be used to determine airflow when a legacy (24 VAC) call is placed on the thermostat inputs of the control. Communicated calls will have CFM requirements as part of the call (when a legacy condenser is attached to a communicating furnace the airflow demand will be transmitted from the communicating thermostat as the installer will configure the cooling airflow requirements for the non-communicating condenser at the thermostat and the airflow requirements for the condenser will be stored at and transmitted from the thermostat).

### D. Cooling/Heat Pump Airflow Trim; S1-6 & S2-7

Two dipswitches (S1-6, S2-7) are to be provided for legacy cool airflow trim. The value used for each selection is specified below. Two of these values are taken from the furnace Model Data file.

Selections are as follows:

S1-6	S2-7	Description
OFF	OFF	No Adjust. (Factory Setting)
ON	OFF	+10%
OFF	ON	-10%
ON	ON	No Adjust.

### E. ODD (On Demand Dehumidification); S2-8

One dipswitch (S2-8) is to be provided to enable the dehumidification feature in legacy mode. Selections are as follows:

S2-8=OFF	ODD not enabled. (Factory Setting)
S2-8=ON	ODD enabled. 0VAC on "HUM STAT" will decrease airflow in cooling.

### F. Tandem Airflow Select; S2-9

One dipswitch (S2-9) shall be used to select the percentage of airflow for the base first stage cooling airflow in legacy mode. Note that further adjustments may also be applied (e.g. for active dehumidification or cooling airflow trim).

# INTEGRATED FURNACE CONTROL

## DIPSWITCHES

<b>Low Cool % of 2<sup>nd</sup> Stage Cooling Airflow</b>	
<b>S2-9</b>	
ON	50%
OFF	75%
OFF is Factory Setting	

### G. Auto Stage; S2-10 & S2-11

There are applications where a single stage thermostat is used with the two stage furnace. With these applications the furnace will initially operate in the low heat stage. Based upon a user selected time, the furnace will automatically stage to high heat stage mode. Auto staging will take place with a 24VAC signal on "W1" when autostaging is turned on. "W2" will be recognized as a call for stage 2 heat even when autostaging is active. The following dipswitches are available to accommodate this requirement:

<b>S2-10</b>	<b>S2-11</b>	<b>AutoStage</b>
OFF	OFF	Normal 2 stage operation (Autostaging is off)(factory setting)
ON	OFF	AutoStage, 10 minutes on low, then to high with call on "W1"
OFF	ON	AutoStage, 15 minutes on low, then to high with call on "W1"
ON	ON	AutoStage, 20 minutes on low, then to high with call on W1"

### H. Continuous Fan Speed; S2-12

One dipswitch (S2-12) is to be provided for legacy continuous fan adjustment.

Selections are as follows:

S2-12 =OFF = 500 CFM for ½ HP, 700 for 3/4HP, 800 CFM for 1 HP motors. (factory setting)

S2-12 =ON = 800 CFM for ½ HP, 1200 for 3/4HP, 1600 CFM for 1 HP motors.

### I. Low Gas Heat Rise (Airflow) Adjustment; S3-13, S3-14

Two dipswitches (S3-13, S3-14) shall be used to select low (1<sup>st</sup> stage) gas heat rise airflow adjustment in legacy mode. Each selection will use a different airflow demand for first stage gas heat. The selections are set to approximate a specified temperature rise as follows. Note: Temperature rise will vary based on conditions and technician should always check temperature rise.

<b>S3-13</b>	<b>S3-14</b>	<b>Target Temperature Rise</b>
OFF	OFF	Nominal Value Specified on Rating Label (Factory Setting) (Approx.)
ON	OFF	Approx. +7°F
OFF	ON	Approx. -7°F
ON	ON	Approx. +12°F

### J. High Gas Heat Rise (Airflow) Adjustment; S3-15, S3-16

Two dipswitches (S3-15, S3-16) shall be used to select high (2nd stage) gas heat rise airflow adjustment in legacy mode. Each selection will use a different airflow demand for second stage gas heat. The selections are set to approximate a specified temperature rise as follows. Note: Temperature rise will vary based on conditions and technician should always check temperature rise.

<b>S3-15</b>	<b>S3-16</b>	<b>Target Temperature Rise</b>
OFF	OFF	Nominal Value Specified on Rating Label (Factory Setting) (Approx.)
ON	OFF	Approx. +7°F
OFF	ON	Approx. -7°F
ON	ON	Approx. +12°F

### K. Heat Blower Off Delay; S3-17, S3-18

Two dipswitches (S3-17, S3-18) can be used to select heat blower off delays (in seconds) in legacy mode.

<b>S3-17</b>	<b>S3-18</b>	<b>Heat OFF Delay (high &amp; low)</b>
OFF	OFF	90 (Factory Setting)
ON	OFF	120
OFF	ON	160
ON	ON	180

### L. Manual Fault Clear

Dipswitch S3-18 also doubles as a means to clear the fault history buffer. The switch can be turned off/on/off/on/off/on (three times) or on/off/on/off/on/off (three times) within less than 30 seconds and the fault buffer will be cleared.

# INTEGRATED FURNACE CONTROL

## MODEL DATA CARD & DUAL SEVEN-SEGMENT DISPLAY

### 13. MODEL DATA CARD CONNECTOR (P6)

There is a factory-installed model data card which is wire-tied to the furnace. At no time should this card be removed from the furnace except during replacement of the control.

#### MODEL DATA CARD

A model data card is defined as an electronic card that carries a copy of the furnace model data.

### WARNING

**DO NOT REPLACE THE FURNACE CONTROL OR MEMORY CARD OF THE FURNACE WITH A FURNACE CONTROL OR MEMORY CARD OF ANOTHER FURNACE OR ANOTHER COMPONENT (E.G.: A MEMORY CARD FROM A CONDENSER OR AIR HANDLER). THE WRONG FURNACE CONTROL OR MEMORY CARD MAY SPECIFY PARAMETERS WHICH WILL MAKE THE FURNACE RUN AT UNDESIRABLE CONDITIONS INCLUDING (BUT NOT NECESSARILY LIMITED TO) REDUCED AIRFLOW DURING HEATING CAUSING EXCESSIVE UNDESIRABLE OPERATION OF THE MAIN LIMIT CONTROL. FURTHER, THE MEMORY CARD IS SPECIFIC TO THE MODEL NUMBER AND BTU INPUT RATING FOR A SPECIFIC FURNACE AND THIS INFORMATION SHOULD NOT BE TRANSPORTED FROM ONE FURNACE (OR COMPONENT) TO ANOTHER.**

The furnace control receives model-specific data from the model data card.

Replacement memory cards with the appropriate furnace model data for any given model can be ordered from the Replacement Parts Division. In the event that the original memory card is lost, the original furnace control has been replaced and there is no furnace model data, the replacement memory card must be ordered and installed into the connector at P6 to give the furnace valid furnace model data. The furnace will not operate properly without the correct furnace model data. When no furnace model data is present either at the memory or on the furnace microprocessor a "d1" (NO MODEL DATA) fault code will be displayed at both the thermostat active fault screen and at the furnace control (I.F.C.) seven-segment displays.

If the original memory card is lost, it should be replaced even if there is valid furnace model data on the IFC microprocessor. The valid furnace model data on the IFC microprocessor should only be considered as a backup to the memory card.

### 14. DUAL SEVEN-SEGMENT DISPLAY AND FAULT CODES (U38)

**NOTE:** Verify display orientation is correct before interpreting fault codes. Otherwise the fault codes may be upside down.

A dual seven segment display shall be provided to display status and diagnostic code information. A fault level 1 is a low-level fault. In general, a level 2 fault is a fault that is severe enough that it prevents furnace or other critical (e.g. cooling) operation. Level 1 faults generally permit operation to continue but operation may not be at optimum performance (e.g. blower operating at power maximum). Standard operating codes (e.g. C for high-stage cooling) are considered fault level "0" as they are not faults at all but only indications of current modes of operation which are considered normal (some operational codes are displayed simultaneously with low level faults which do not interrupt operation - see paragraphs below for details).

Since usually only one fault can be displayed at the seven-segment display at any given time (see exceptions below), the fault displayed when two or more faults are present at the same time shall be resolved by the fault code list below which calls out the fault code priority. Lower numbers are considered higher priority than larger numbers. Therefore, fault code priority 0 has the highest priority and shall be displayed when present regardless of any other fault that might also be present at the same time. This mechanism does not prevent simultaneous faults from being logged into the fault code buffer.

The mode displays for heat mode ("h" "H") shall reflect the demand from the thermostat. This includes when only a first stage heat call; "W1" is present ("W2" not present), the mode displayed should reflect the first stage demand by displaying the lower-case "h" and not the actual output of the furnace during ignition (since this configuration ignites at high stage).

Three exceptions to this rule exist as follows:

1. When the thermostat demand is for high stage and only low heat can be provided because the high pressure switch will not close or has opened and will not re-close. In this case, the mode "h" (low heat) shall be displayed alternately along with the fault "57" (open high pressure switch) (See item 5 below in this section).
2. When autostaging has been activated and a response to "W1" heat has been increased to high heat by the furnace control after the user-specified time even though a call for high heat ("W2") is not present. In this case a capital "H" shall be displayed and not a lower-case "h".

# INTEGRATED FURNACE CONTROL

## DUAL SEVEN-SEGMENT DISPLAY

3. For 90+ furnaces only: Low pressure switch fails 5 times in one heat call. Then device is forced to the high rate to reveal possible **Water Sensed** condition. An upper-case "H" is displayed in this circumstance regardless of the thermostat demand.

When the furnace is in a heat or cool blower off elay, the display should be "0".

A standard operating code (with fault level "0") shall be displayed steady-on.

When displaying a fault code, it shall be flashed and not be displayed steady-on. It shall be flashed on for one second, then off for ½ second then on again. Cycle repeats until the fault is cleared. Each fault is flashed (displayed) a minimum of two times even if the fault condition has cleared before the fault can be displayed twice.

### Dual Faults Displayed

Normally only one fault or status character is displayed at the Seven-segment display at any given time. Exceptions for some dual faults are noted below.

Sequence of display:

- A. The first fault will be displayed for one second
- B. The upper-most horizontal segment of the right seven-segment display is energized for ½ second
- C. The second fault is displayed for one second
- D. The upper-most horizontal segment of the right seven-segment display is energized for ½ again.

This cycle repeats until one or both faults are gone or otherwise as noted below:

1. When both high pressure switch and low pressure switch are open and both should be closed fault codes "45" and "57" will be displayed alternately as described above (A-D).
2. When a failed ignition has occurred four times in a row, the control enters one-hour lockout and fault codes "10" and "11" will be displayed alternately as described above (A-D).
3. When flame is lost five times in a row, the control enters one-hour lockout and fault codes "10" and "13" will be displayed alternately as described above (A-D).
4. When both the high pressure switch and low pressure switch are closed and both should be open (as in during the pressure switch proving period). In this case fault codes "44" and "55" will be displayed alternately as described above (A-D).
5. When the high pressure switch is open and the demand from the thermostat is set to 100% heat. . . In this case the operation code "h" (for low heat) and the fault code "57" (open high pressure switch) will be displayed alternately.
6. While the control is in one-hour lockout due to an unexpected flame, the fault codes "14" (unexpected flame) and "10" (soft lockout) will be displayed alternately as described above (A-D).
7. While the control has entered a one-hour lockout after declaring a dead blower after the main limit control has been open for more than 150 seconds, the fault codes "61" (Non-operational blower) and "10" (soft lockout) will be displayed alternately as described above (A-D). Note: the dead blower fault and associated one-hour lockout will occur up to four times in one heat call. Upon declaring this fault for the fourth time in one heat call, the control will enter hard lockout.
8. When the main limit has been open during a gas heat call for more than 150 seconds and has not yet re-closed, the fault codes "61" (Non-operational blower) and "22" (open limit) will be displayed alternately as described above (A-D) until the limit re-closes.
9. When the water level sensor has declared a 1-hr lockout after declaring a **Water Sensed** condition (heating operation is shut down due to this fault) several times consecutively. When the control enters lockout the fault codes "59" (**Water Sensed**) and "10" (soft lockout) will be displayed alternately as described above (A-D).
10. When IFC is in soft lockout and fault "93" is active, the fault code "93" is to be displayed alternately with the fault code "10".
11. When gas valve is open, flame is sensed and IFC detects a fault condition which will not prevent gas heating operation from continuing (like fault "57", "12", "66",...), IFC will display the operation code "h" or "H" alternately with the active fault code.

# INTEGRATED FURNACE CONTROL

## DUAL SEVEN-SEGMENT DISPLAY

The fault and mode codes and fault priorities are listed below. Priority is to be used to determine which fault to display when two or more faults are present simultaneously.

**NOTE:**

Verify display orientation is correct before interpreting fault codes. Otherwise the fault codes may be upside-down. If a fault code is not on this list, the display may be upside down.

Priority	Code	Description	Fault Level
0	30	Open Fuse	2
1	93	Internal Control Fault Detected	2
2	d1	No Model Data	2
3	68	No Blower Communications	2
4	61	Blower Fault - Motor Can NOT Run	2
5	26	Line and Neutral Reversed or Poor Ground	2
6	58	Water Circuit Open	2
7	14	Flame Present with Gas Valve Off	2
8	33	Over Temperature Switch (RollOut) Open	2
9	23	Auxiliary Limit Switch Open	2
10	22	Main Limit Switch Open	1,2
11	59	Water Sensed	2
12	10	One-hour Lockout	2
13	44	Low Pressure Switch Closed, Inducer Off	2
14	45	Low Pressure Switch Open, Inducer on High Speed	1,2
15	46	Low Pressure Switch Open, Inducer on Low Speed	1,2
16	55	High Pressure Switch Closed, Inducer Off	2
17	57	High Pressure Switch Open, Inducer on High Speed	1,2
18	11	Failed Ignition	1,2
19	13	Flame Lost after Established	1
20	66	Blower Cutback	1
21	60	Blower Fault - Blower Can Still Run	1
22	12	Low Flame Sense Current	1
23	H	Call for High Heat	0
24	h	Call for Low Heat	0
25	C	Call for High Cooling Present	0
26	c	Call for Low Cooling Present	0
27	cd	Low Cooling with Dehumidification Active	0
28	Cd	High Cooling with Dehumidification Active	0
29	hP	Low Heat Pump Operation	0
30	HP	High Heat Pump Heating Operation	0
31	dF	DeFrost Operation	0
32	F	Call for Fan Present	0
33	82	Supply Air Sensor Fault	1
34	84	Outdoor Air Sensor Fault	1
35	81	Return Air Sensor Fault	1
36	d4	No Valid Model Data on Memory Card	1
37	d6	Horsepower Conflict on Memory Card	1
38	0	System Off, Standby Mode no Thermostat Calls or Errors.	0
39	99	Remote Faults Reset Performed	1

# INTEGRATED FURNACE CONTROL

## PUSHBUTTON

### 15. PUSHBUTTON (S8)

The status mode is entered when the pushbutton is pressed for less than 2 seconds. While in the Status menu at the seven segment displays, the category field is displayed first for one second immediately followed by the appropriate value for one second. This cycle repeats until 60 seconds has expired or the pushbutton has been pushed again for less than two seconds. If the button is pressed again for less than 2 seconds within the 60 second period, the next field will be displayed and the 60 second timer will be reset. After displaying all of the categories listed, the control will loop back to the first category when the button is pressed again for less than 2 seconds.

If within the status menu, if the button is pressed for more than 2 seconds but less than 5 seconds, the display will exit the status menu upon release of the push-button. Otherwise, the status menu will automatically exit if no activity is sensed on the pushbutton for 60 seconds.

The categories will be displayed in the following sequence:

Category	Information
FL	Up to six faults (Example: —21-14-29—)
AF	IBM CFM (Example: 1251 = 12-51, 745 = 7-45)
Fr	Fire rate % (Example: 70)
UI	Furnace size
tr	Temperature Rise in Degrees F (example 75)*

\*If the Supply air temp sensor is not available the category will not be displayed.

#### **Fault history display (FL)**

Up to 6 faults are stored in the buffer with the most recent replacing the oldest fault.

Unless otherwise specified, when a fault becomes active it is to be stored in non-volatile memory provided no more than three occurrences of any given fault code are already stored in the fault buffer. If a fault occurs and there are already 3 occurrences of the same fault in the buffer, the current fault will replace the oldest of the same fault in the buffer but will become the most recent fault displayed.

Before updating the fault history the history will be examined for the previous most recent record. If the most recent record in the history is the same fault number but has a lower fault level than the new fault, then instead of adding the new fault to the buffer, the previous fault and level are replaced with the new fault and level. The time

stamp will also be updated. This way, the existing fault will be updated but a new fault will not be added.

Faults older than 168 powered hours will be automatically deleted from the fault buffer.

When fault recall is activated, the six most recent faults which have occurred within 1 week (168 powered hours) will be displayed on the seven segment display in succession from the most recent to the oldest.

When displaying fault codes stored in the buffer, the control will flash the A and D segments of the least most significant SSD for ½ second to indicate the beginning of the fault recall. Each fault shall be displayed steady for one second followed by energizing the top segment (A or D depending on the position of the Display Orientation Dip-switch) of the least significant (right most) Seven-segment display for ½ second followed by the next fault displayed for one second. This cycle repeats until all faults in the buffer are displayed. After all of the faults are displayed, the control will again energize the A and D segment of the least significant S.S.D. for ½ second.

#### **Airflow Display (AF)**

Displayed CFM range is between 100 and 9999 per following sequence:

The sequence repeats until the status menu is exited or

Step	1	2	3	4
Time (sec)	1	0.5	1	2
Example (1246)	"12"	Off	"46"	Off
Example (721)	"7" (right segment)	Off	"21"	Off

the pushbutton is pressed again.

#### **Fire Rate Display (Fr)**

Gas heat fire rate is displayed for 1 second as follows:

"0" is displayed when flame is not lit.

"HI" is displayed when flame is lit and the fire rate is high.

"Lo" is displayed when flame is lit and the fire rate is low.

#### **Model BTU Capacity/1000 (Unit Input) (UI)**

The furnace input BTU will be taken from the model data field **Furnace BTU's/1000**. Values less than 100 will be displayed as two digits (example 70 displayed as 70). Values of 100 or greater will be displayed as three digits. The most significant digit will be displayed for one second on the left SSD followed by the remaining two digits which are also displayed for one second. Example: 117 would be displayed as 1 followed by 17.

#### **Temperature Rise (tr)**

Temperature rise is to be displayed (Supply Temp – Return Temp). If the Supply air temp sensor is not available the category will not be displayed.

# INTEGRATED FURNACE CONTROL

## PUSHBUTTON

### Clearing Fault History

The fault buffer can be cleared with the pushbutton while the Fault History Display (FL) menu is active by holding down the pushbutton for 5 seconds or more. For indication that the fault buffer is clear the IFC will flash segments A and D of the right-most seven segment displays one second on and one second off three times after the fault clear command has been recognized.

The fault history can also be cleared through the *HW1SHOTS* write command message when *Clear Alarm History Command* field is set. Display will flash segments A and D as described in the paragraph above.

### Extended Display Mode

If the pushbutton is pressed during the power-up sequence, IFC will turn on the extended display mode. The extended display mode modifies the display operation per the following table:

**EXTENDED DISPLAY MODE – DISPLAY PROPERTIES**

Mode:	Step:	1	2	3	4	5	6	7	8	9	10
Fault	Info:	Err.Num.	pause								
	Duration:	1sec	0.5sec								
	Example:	"68"									
Dual Fault	Info:	1.Err. Num.	SEGA	2.Err.Num.	SEGA						
	Duration:	1sec	0.5sec	1sec	0.5sec						
	Example:	"45"	"-"	"57"	"-"						
Heating - ign. Defrost - ign.	Info:	Mode	Fire rate	FR value							
	Duration:	1sec	0.5sec	1sec							
	Example:	"h" "dF"	"FR"	"40"							
Heating - run Defrost - Ign.	Info:	Mode	Fire rate	FR value	CFM	CFM value	CFM value2	pause			
	Duration:	1sec	0.5sec	1sec	0.5sec	1sec	1sec	2sec			
	Example:	"h" "dF"	"FR"	"40"	"AF"	"13"	"00"				
Heating - run with an error	Info:	Err. Num.	SEGA	Mode	SEGA	Fire rate	FR value	CFM	CFM value	CFM value2	pause
	Duration:	1sec	0.5sec	1sec	0.5sec	0.5sec	1sec	0.5sec	1sec	1sec	2sec
	Example:	"57"	"-"	"h"	"-"	"FR"	"40"	"AF"	"13"	"00"	
Idle (blower active)	Info:	Mode	CFM	CFM value	CFM value2	pause					
	Duration:	1sec	0.5sec	1sec	1sec	2sec					
	Example:	"0"	"AF"	"5"	"00"						
HP/Cool/FAN (blower active)	Info:	Mode	CFM	CFM value	CFM value2	pause					
	Duration:	1sec	0.5sec	1sec	1sec	2sec					
	Example:	"c"	"AF"	"11"	"00"						

The extended display mode remains active until power re-cycle or microprocessor reset.

# INTEGRATED FURNACE CONTROL

## SUPPLY & OUTDOOR AIR TEMPERATURE SENSORS

### 16. SUPPLY AND OUTDOOR AIR TEMPERATURE SENSOR INPUTS (T4)

Optional field installed supply air and outdoor air sensors (10K NTC thermistor) shall be read from the T4 screw terminal block.

Control to resolve temperature within  $\pm 2^{\circ}\text{F}$  at  $70^{\circ}\text{F}$

There is to be an automatic detection of the supply and outdoor air sensors. If the resistance between the terminals is within a valid 10K thermistor range (supply air temp range =  $-40^{\circ}\text{F}$  to  $200^{\circ}\text{F}$ , outdoor air temp range =  $-40$  to  $200^{\circ}\text{F}$ ), both sensors temperatures will be accessible.

If the resistance between the supply air terminals is determined to be out of range to a high resistance, it shall be interpreted as an uninstalled supplied air sensor and shall not cause an error condition unless a valid thermistor value was previously sensed on the same power cycle. If the sensor was determined to be present and then is opened the control should display a fault "82". The fault is a level 1 fault and will not inhibit furnace operation. Also, if the resistance between the terminals is determined to be out of range to a low resistance and a valid thermistor value was sensed on

the same power cycle, a fault "82" is to be displayed on the seven segment displays.

If the resistance between the outdoor air terminals (OAT) is determined to be out of range to a high resistance, it shall be interpreted as an uninstalled supplied outdoor air sensor and shall not cause an error condition unless a valid thermistor value was previously sensed on the same power cycle. If the sensor was determined to be present and then is opened the control should display a fault "84". The fault is a level 1 fault and will not inhibit furnace operation.

Also, if the resistance between the terminals on the OAT is determined to be out of range to a low resistance, a fault "84" is to be displayed on the seven segment displays only if a valid thermistor value was previously sensed on the same power cycle.

Fault codes "82" and "84" shall only be present for three minutes after the fault is detected. After three minutes has expired, the fault will no longer be set even if the condition creating the fault is still present. These faults are also only logged into the fault buffer one time. Should the sensor error later clear and then appear again the same sequence as noted previously will be repeated.

**FIGURE 51**  
WIRING OF SUPPLY AIR (SA) AND OUTDOOR AIR (OAT) TEMPERATURE SENSORS.

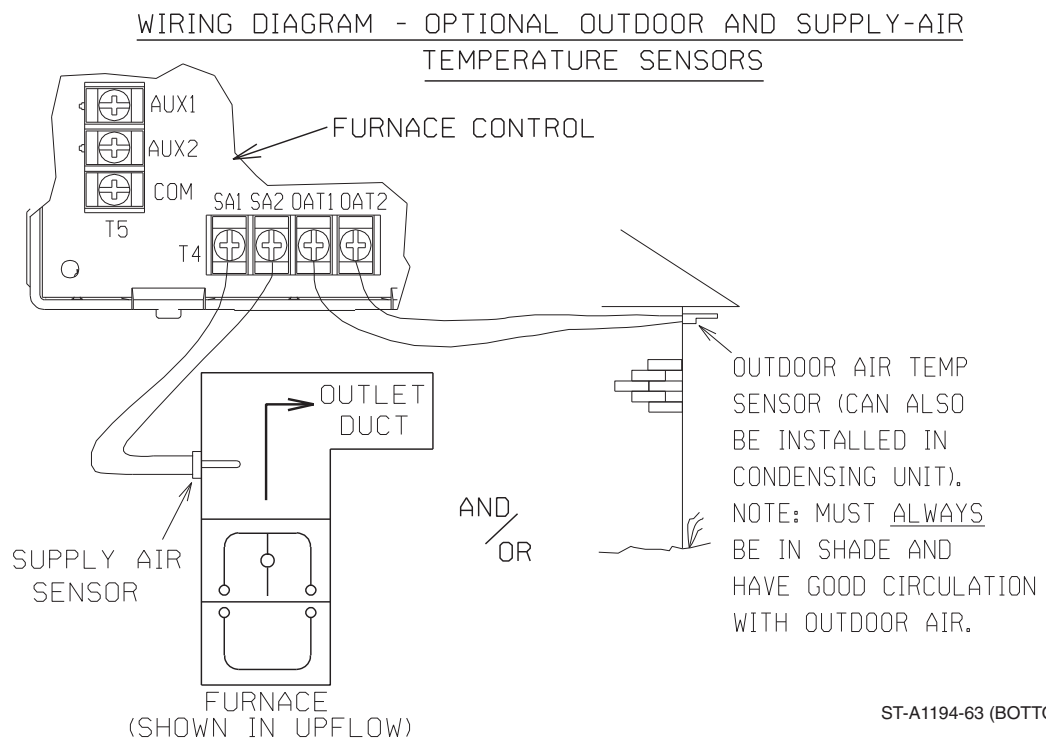

# INTEGRATED FURNACE CONTROL

## AUXILIARY INPUTS

### 17. AUXILIARY INPUTS (COMMUNICATING SYSTEMS ONLY) (T5) (SEE FIGURE 52)

Terminal T5 is provided for field installation of up to two auxiliary switches. The auxiliary inputs shall be used to provide a means of using traditional drain pan switches, smoke detectors, freeze switches, etc. The inputs are to be labeled **Aux 1** and **Aux 2**. The switch inputs are for communicating systems only. One or both inputs can be configured at the communicating

thermostat as either normally-opened or normally closed contacts. System operation when the contacts either open or close can be configured at the communicating thermostat.

A resistance of greater than 1k ohms to common shall be detected as an open switch and a resistance of less than 100 ohms shall be recognized as a closed switch.

**FIGURE 52**  
WIRING OF AUXILIARY INPUTS (USE WITH COMMUNICATING SYSTEMS ONLY).

### WIRING DIAGRAM - OPTIONAL AUXILLIARY INPUTS

NOTE: AUXILLIARY INPUTS ARE ONLY MONITORED IN COMMUNICATING MODE.

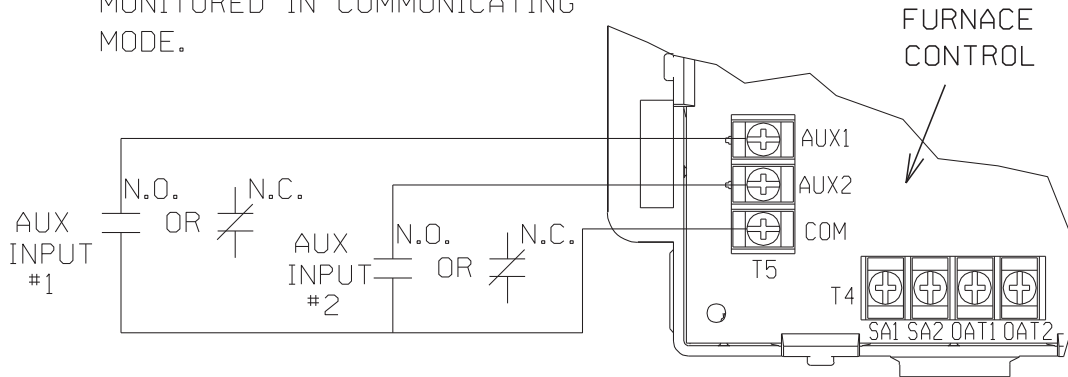

NOTE: EITHER A NORMALLY-OPENED (N.O.) OR NORMALLY-CLOSED (N.C) ACCESSORY CAN BE ATTACHED TO AUXILLIARY INPUTS 1 AND/OR 2. SELECT CONFIGURATION (N.O. OR N.C.) AT THE COMMUNICATING THERMOSTAT.

ST-A1194-63 (TOP)

# INTEGRATED FURNACE CONTROL

## THERMOSTAT WIRING DIAGRAMS

### 18. THERMOSTAT INPUTS (T2) – THERMOSTAT WIRING DIAGRAMS

Both communicating and legacy thermostats are to be connected at terminal block T2.

#### A. COMMUNICATING SYSTEMS

The furnace is capable of communicating with a thermostat and condenser to improve cooling and heat-pump airflow, displaying active faults and active furnace information at the thermostat and improved diagnostics and troubleshooting.

#### WIRING A FURNACE FOR COMMUNICATIONS.

Maximum wire lengths and notes about wiring communicating systems are noted below.

#### MAXIMUM COMMUNICATING WIRE LENGTHS (E1, E2, R & C)

Max Wire Length – Thermostat to Furnace = **125 FT @ 18 AWG\***

Max Wire Length – Furnace to Condenser = **125 FT @ 18 AWG\***

Max Wire Length – Between any 2 devices = **125 FT @ 18 AWG\***

Sum Max Total Wire Length for All Components = 500 ft (see Figure 53)

Notes:

1. Wires may be solid or stranded.

2. \*Wire gage smaller than 18 AWG is not approved or recommended for this application.
3. If the thermostat wiring will be located near or in parallel with high voltage wiring, cable TV, Ethernet wiring, or radio frequency equipment, then shielded thermostat wire can be used to reduce or eliminate potential interference. The shielding must be contiguous (have continuity) across all devices and all wire segments. This should be done by twisting the shielding wires from adjacent segments together. Further, the shielding for the entire system must be grounded in a single location. Multiple grounds on the shielding system are NOT permitted. The shield wire should be connected to the C terminal, or ground, at the indoor unit. The shield wire should NOT be connected to any terminal at the Control Center (aka;Thermostat). Connecting the shield to ground at both ends can cause current loops in the shield, reducing shield effectiveness.
4. When using existing wire from a previous installation, be sure to trim the tip of the wire back past the insulation and strip a small amount of insulation from the wire to expose clean new copper for the communicating connections. Fresh copper must be exposed when making the communicating connections or communications may not be properly established.

#### A1. WIRING OF COMMUNICATING THERMOSTATS.

**FIGURE 53**  
WIRING DIAGRAM FOR A FULLY COMMUNICATING SYSTEM.

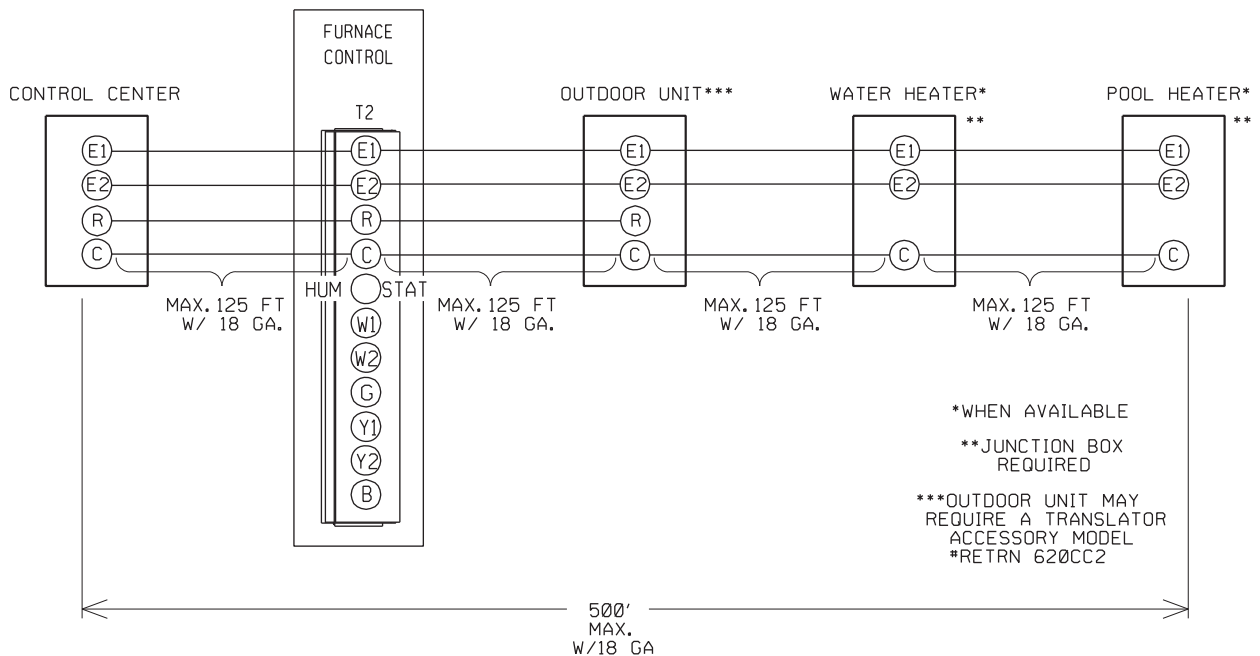

THIS IS THE ONLY APPROVED CONFIGURATION

ST-A1217-01

# INTEGRATED FURNACE CONTROL

## THERMOSTAT WIRING DIAGRAMS

Figure 53 is the wiring diagram for connecting the furnace to an approved EcoNet communicating thermostat and approved EcoNet communicating condenser. The only approved configuration is to install dedicated wires directly from the furnace to the thermostat and a separate set of dedicated wires directly from the furnace to the condenser.

Additional EcoNet devices can be added to the system as shown in Figure 53. The approved wiring configuration is the daisy-chain configuration shown in Figure 53. A star wiring configuration is not approved and should not be used.

Note: The only approved configuration requires that four dedicated wires (E1, E2, R and C) be installed from the furnace to the condenser.

- A2. SPECIAL CONFIGURATION – WIRING OF NON COMMUNICATING CONDENSORS AND HEAT-PUMPS WITH COMMUNICATING FURNACE AND THERMOSTAT (SEE FIGURE 54).

**FIGURE 54**  
WIRING DIAGRAM FOR NON-COMMUNICATING CONDENSORS AND HEAT-PUMPS WITH COMMUNICATING FURNACE AND THERMOSTAT.

### A. WIRING DIAGRAM

SPECIAL CONFIGURATION:  
COMMUNICATING THERMOSTAT AND FURNACE  
WITH NON-COMMUNICATING CONDENSER  
(SINGLE - STAGE ONLY CONDENSER)

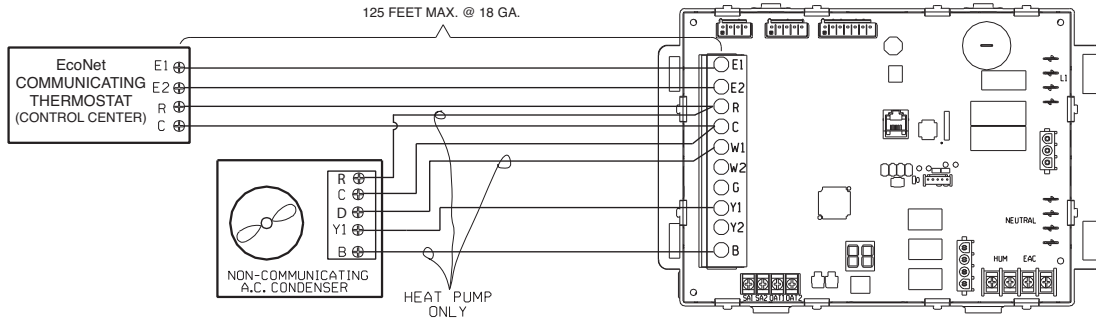

### B. WIRING DIAGRAM

SPECIAL CONFIGURATION:  
COMMUNICATING THERMOSTAT AND FURNACE  
WITH NON-COMMUNICATING CONDENSER  
(TWO - STAGE ONLY CONDENSER)

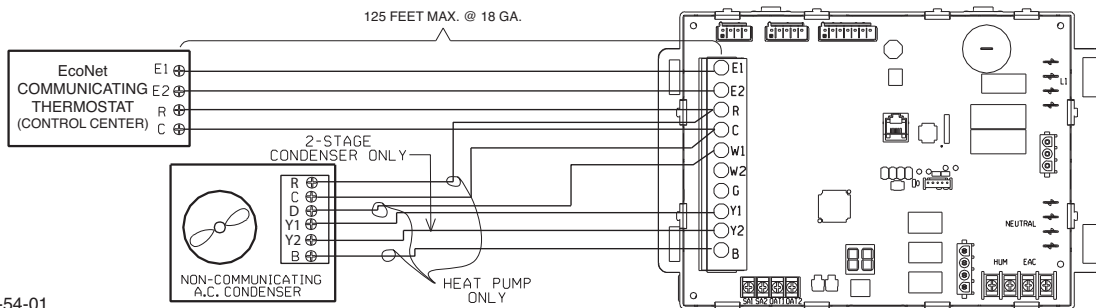

ST-A1194-54-01

# INTEGRATED FURNACE CONTROL

## THERMOSTAT WIRING DIAGRAMS

### B. SYSTEMS WITH LEGACY THERMOSTATS

B1. WIRING OF A 1-STAGE LEGACY THERMOSTAT WITH AUTOSTAGING SELECTED (SEE FIGURE 55).

B2. WIRING OF A 2-STAGE LEGACY THERMOSTAT (SEE FIGURE 56)

**FIGURE 55**  
WIRING DIAGRAM FOR A LEGACY 1-STAGE THERMOSTAT WITH AUTOSTAGING.

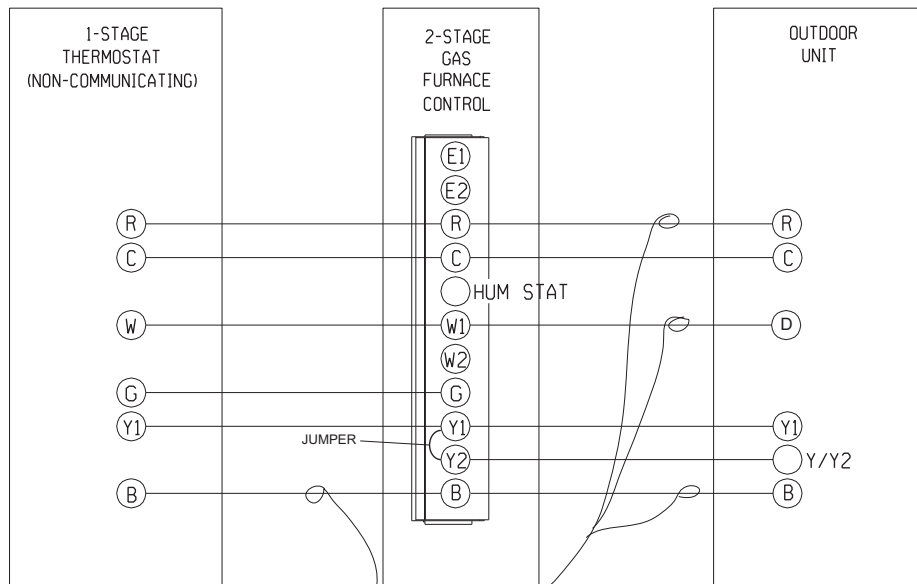

**NOTE:** For 1 stage cooling a jumper between Y1 and Y2 is required!

**NOTE:** FOR TIMED STAGING, THE DIPSWITCHES 10 AND 11 (S2-10 AND S2-11) MUST NOT BE LEFT IN THE 'OFF' POSITION. IF THE SWITCHES ARE LEFT IN THE 'OFF' POSITION WITH THIS CONFIGURATION, THE FURNACE WILL NEVER GET TO HIGH STAGE HEAT. (SEE DIPSWITCH SECTION OF THIS BOOK)

ST-A1194-61-01

# INTEGRATED FURNACE CONTROL

## THERMOSTAT WIRING DIAGRAMS

**FIGURE 56**  
WIRING DIAGRAM FOR A LEGACY 2-STAGE THERMOSTAT.

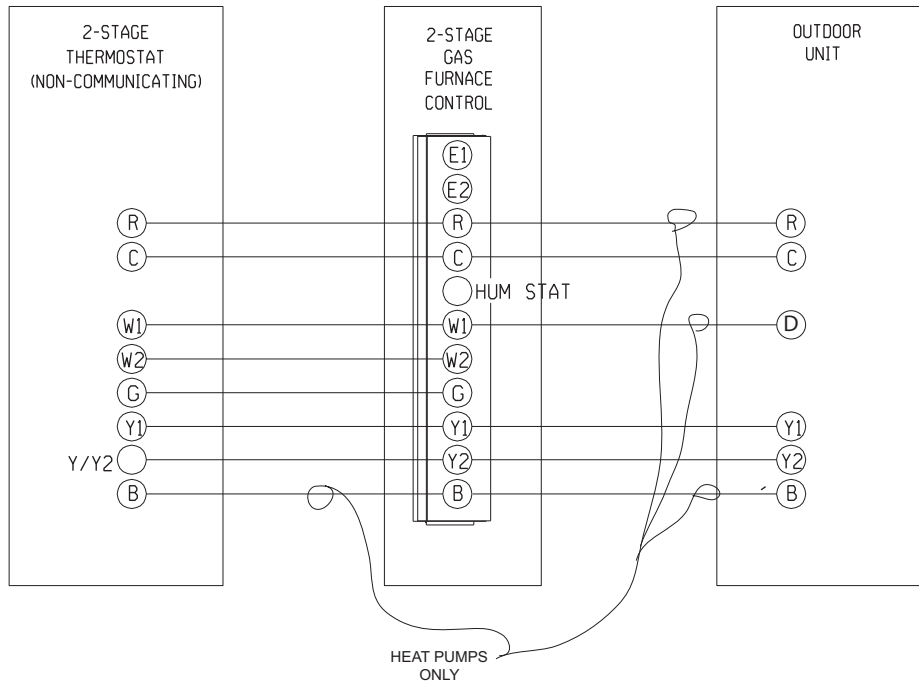

ST-A1194-62-01

### 19. 24VAC AND COMMON CONNECTIONS (E10/E11)

For connection to the low voltage side of the control transformer. Terminals are ¼" quick-connect style.

### 20. FUSE (P100/P101)

A fuse is provided to protect low-voltage (24VAC) circuits from shorts between 24VAC and Ground or

Common. A fault code 30 is displayed at the furnace control when the fuse has been opened.

On the next page is a timing diagram for normal heat sequence. This diagram assumes no faults are present during the heat call.



# FIELD ADJUSTMENTS

**TABLE 18**  
METER TIME

METER TIME IN MINUTES AND SECONDS FOR NORMAL INPUT RATING OF FURNACES EQUIPPED FOR NATURAL GAS OR L.P.											
INPUT (BTU/HR)	METER SIZE (FT <sup>3</sup> /REV)	HEATING VALUE OF GAS (BTU/FT <sup>3</sup> )									
		900		1000		1040		1100		2500	
		MIN	SEC	MIN	SEC	MIN	SEC	MIN	SEC	MIN	SEC
56,000	ONE	0	58	1	4	1	7	1	11	2	41
	TEN	9	39	10	43	11	9	11	47	26	47
70,000	ONE	0	46	0	51	0	53	0	57	2	9
	TEN	7	43	8	34	8	55	9	26	21	26
84,000	ONE	0	39	0	43	0	45	0	47	1	47
	TEN	6	26	7	9	7	26	7	51	17	51
98,000	ONE	0	33	0	37	0	38	0	40	1	32
	TEN	5	31	6	7	6	22	6	44	15	18
112,000	ONE	0	29	0	32	0	33	0	35	1	20
	TEN	4	49	5	21	5	34	5	54	13	24

Formula: Input BTU/HR =  $\frac{\text{Heating Value of Gas (BTU/FT}^3\text{)} \times 3600 \times \text{correction factor}}{\text{Time (in seconds) for 1 cubic FT of Gas}}$

Field Selections

## SETTING INPUT RATE

The furnace is shipped from the factory with #51 orifices. They are sized for natural gas having a heating value of 1100 BTU/cu. ft. and a specific gravity of .60.

Since heating values vary geo-graphically, the manifold pressure and/or gas orifice size may need to be changed to adjust the furnace to its nameplate input. Consult the local gas utility to obtain the yearly average heating value

and orifice size required to fire each individual burner at 14,000 BTU/HR.

**NOTE:** Refer to the High Altitude Section of this manual and the National Fuel Gas Code for high altitude rate adjustment above 2,000 ft.

## AIR FLOW

The importance of proper air flow over the heat exchanger cannot be over emphasized.

**NOTE:** Where the maximum airflow is expected to be over 1800 CFM, BOTH sides or the bottom must be used for the return air.

### ⚠ CAUTION

IT IS IMPORTANT THAT EACH DUCT SYSTEM BE SIZED AND INSTALLED FOR THE SPECIFIC APPLICATION BY PROPERLY APPLYING THE APPROPRIATE INDUSTRY ACCEPTED STANDARD. IF LESS THAN MINIMUM STANDARDS ARE APPLIED, THE EQUIPMENT USER COULD EXPECT TO EXPERIENCE HIGHER UTILITY BILLS, MAJOR COMPONENT FAILURE, VARYING DEGREES OF AIR NOISE OR OTHER UNSATISFACTORY ISSUES, OVER WHICH THE MANUFACTURER HAS NO CONTROL.

## TEMPERATURE RISE CHECK

To determine if the air flow is correct, make a temperature rise check.

1. Insert a thermometer in the supply air duct as close to the furnace as possible yet out of a direct line from the heat exchanger. See Figure 57.
2. Insert a thermometer in the return air duct as close to the furnace as possible.
3. Operate the furnace for a minimum of 15 minutes in gas heat mode.
4. When the thermometer in the supply air duct stops rising (approximately five minutes), subtract the return air temperature from the supply air temperature. The difference is the temperature rise.
5. Compare the measured temperature rise to the approved temperature rise range listed on the furnace name plate. See Figure 58.

**FIGURE 57**  
TEMPERATURE RISE MEASUREMENT



If the measured temperature rise is above the approved range, the air flow is too low. Airflow must be increased by speeding up the blower, by removing restrictions in the duct system, or by adding more supply or return air duct. If the measured temperature rise is below the approved range, the air flow is too much. Use lower speed tap on the multi-speed blower.

### ⚠ WARNING

THE MEASURED TEMPERATURE RISE SHOULD BE AS CLOSE TO THE MIDDLE OF THE STATED RANGE AS POSSIBLE. FOR EXAMPLE, IF THE RISE RANGE IS 40 TO 70°F (4.5°-21°C), THE MIDDLE OF THE RISE RANGE IS 55°F (12.8°C). IN ALL APPLICATIONS, THE INSTALLER MUST ADJUST THE TEMPERATURE RISE TO THIS "MIDDLE" POINT AS CLOSELY AS POSSIBLE. ALSO, THE TEMPERATURE RISE SHOULD NEVER BE ABOVE OR FALL BELOW THE STATED RANGE. DOING SO COULD CAUSE DAMAGE TO THE HEAT EXCHANGER OR INTERMITTENT OPERATION. THIS COULD CAUSE INJURY OR DEATH AND WILL VOID THE MANUFACTURER'S WARRANTY FOR THIS PRODUCT.

**FIGURE 58**  
TYPICAL FURNACE NAME PLATE

RHEEM MANUFACTURING COMPANY  
FORT SMITH, ARKANSAS

MODEL NO./NUMERO DE MODELE: R96VA0701327MSA  
SERIAL NO./NUMERO DE SERIE: W0000100001 MFG. DATE [SEE DATE NOTE]

CONTROL SYSTEM JC

CATEGORY IV FORCED AIR FURNACE WHEN USING INDOOR AIR FOR COMBUSTION  
CATEGORY IV TYP FSP DIRECT VENT FORCED AIR FURNACE WHEN USING OUTDOOR AIR FOR COMBUSTION. FOR INDOOR INSTALLATION ONLY, IN A BUILDING CONSTRUCTED ON-SITE.  
CATÉGORIE IV GÉNÉRATEUR D'AIR CHAUD À AIR FORCÉE LORSQUE DE L'AIR INTÉRIEUR EST EMPLOYÉ POUR LA COMBUSTION. CATÉGORIE IV TYPE FSP ÉVACUATION DIRECTE GÉNÉRATEUR D'AIR CHAUD À AIR FORCÉE LORSQUE DE L'AIR EXTÉRIEUR EST EMPLOYÉ POUR LA COMBUSTION. POUR INSTALLATION À L'INTÉRIEUR SEULEMENT, DANS UN BÂTIMENT CONSTRUIT SUR LE SITE.

ELECTRIC 115 V. 60 HZ 1 PH., MAXIMUM TOTAL INPUT 6.3AMPS  
ELECTRIQUE 115 V. 60 HZ 1 PH., PUISSANCE D'ENTRÉE TOTALE MAXIMUM 6.3 A.  
MAXIMUM OVERCURRENT PROTECTION 15 AMPERES. DISJONCTEUR À MAXIMA 15 A.

HOURLY INPUT RATING DEBIT CALORIFIQUE		HOURLY INPUT RATING DEBIT CALORIFIQUE		FACTORY EQUIPPED FOR AGENCE A L'USINE POUR
MAXIMUM	MINIMUM	MAXIMUM	MINIMUM	FOR GAS / GAZ
Btu/hr	(Kw)	Btu/hr	(Kw)	NATURAL / NATUREL
75,000 (21.98)				

PLEASE REFER TO BOOKLET #92-101825-01 FOR INPUT CALCULATIONS  
IN THE U.S. AT ELEVATIONS ABOVE 2,000 FT. (610M), DERATE THE INPUT 4% PER 1,000 FT. (305M) ABOVE SEA LEVEL  
THIS APPLIANCE EQUIPPED FOR ALTITUDES / CET APPAREIL EST ÉQUIPÉ POUR ALTITUDES COMPRISES  
ENTRE 0-4,500' / (0-1,372) FT.(M)/PIEDS(M)

ORIFICE / INJECTEUR .51 DMS  
LIMIT SETTING/LIMITE COUPE-CIRCUIT 120° (49°) °F (°C)  
AUXILIARY LIMIT SETTING/  
LIMITE COUPE-CIRCUIT AUXILIAIRE °F (°C)

	NATURAL GAS/ GAZ NATUREL	LP GAS OR PROP/ GAZ DE PÉTROLE LIQUÉFIÉ OU PROP.
MAXIMUM PERMISSIBLE GAS SUPPLY PRESSURE TO FURNACE PRESSION MAXIMUM D'ALIMENTATION EN GAZ À CHAUDIÈRE	10.5 (2.61)	13.0 (3.23)
MINIMUM GAS SUPPLY PRESSURE FOR PURPOSES OF INPUT ADJUSTMENT PRESSION MINIMUM D'ALIMENTATION EN GAZ POUR LE RÉGLAGE DE PUISSANCE D'ENTRÉE	5.0 (1.24)	11.0 (2.73)
MANIFOLD PRESSURE / PRESSION A LA TUBULURE	3.5 (0.87)	10.0 (2.49)

AIR TEMPERATURE RISE/  
AUGMENTATION DE LA TEMPÉRATURE DE L'AIR  
HIGH FIRE / LE FEU ÉLEVÉ 40° (22°) - 70° (39°) °F (°C)  
LOW FIRE / LE BAS FEU °F (°C)

MAXIMUM EXTERNAL STATIC PRESSURE PRESSION STATIQUE EXTÉRIEURE MAXIMAL	INCHES W.C. (kPa) - P.O. C.E. (kPa)
.15	(.038)
.70	(.178)

ASSEMBLED IN MEXICO 91-22176-11

# MAINTENANCE

## MAINTENANCE

### **⚠ WARNING**

THESE INSTRUCTIONS ARE INTENDED AS AN AID TO QUALIFIED SERVICE PERSONNEL FOR PROPER INSTALLATION, ADJUSTMENT AND OPERATION OF THIS UNIT. READ THESE INSTRUCTIONS THOROUGHLY BEFORE ATTEMPTING INSTALLATION OR OPERATION. FAILURE TO FOLLOW THESE INSTRUCTIONS MAY RESULT IN IMPROPER INSTALLATION, ADJUSTMENT, SERVICE OR MAINTENANCE, POSSIBLY RESULTING IN

FIRE, ELECTRICAL SHOCK, CARBON MONOXIDE POISONING, EXPLOSION, PROPERTY DAMAGE, PERSONAL INJURY OR DEATH.

DISCONNECT MAIN ELECTRICAL POWER TO THE UNIT BEFORE ATTEMPTING ANY MAINTENANCE. FAILURE TO DO SO CAN CAUSE ELECTRICAL SHOCK RESULTING IN PERSONAL INJURY OR DEATH.

## FILTERS

### **⚠ CAUTION**

DO NOT OPERATE THE SYSTEM FOR EXTENDED PERIODS WITHOUT FILTERS. A PORTION OF THE DUST ENTRAINED IN THE AIR MAY TEMPORARILY LODGE IN THE AIR DUCT RUNS AND AT THE SUPPLY REGISTERS. ANY RECIRCULATED DUST PARTICLES WILL

BE HEATED AND CHARRED BY CONTACT WITH THE FURNACE HEAT EXCHANGER. THIS RESIDUE WILL SOIL CEILINGS, WALLS, DRAPES, CARPETS AND OTHER HOUSEHOLD ARTICLES.

## LUBRICATION

**IMPORTANT: DO NOT** attempt to lubricate the bearings on the blower motor or the induced draft blower motor. Addition of lubricants can reduce the motor life and void the warranty.

The blower motor and induced draft blower motor are permanently lubricated by the manufacturer and do not require further attention.

It is recommended that the blower motor and induced draft blower motor be cleaned periodically by a qualified installer, service agency, or the gas supplier to prevent the possibility

of overheating due to an accumulation of dust and dirt on the windings or on the motor exterior. And, as suggested elsewhere in these instructions, the air filters should be kept clean. Dirty filters can restrict airflow. The motor depends upon sufficient air flowing across and through it to keep from overheating.

# MAINTENANCE

## SYSTEM OPERATION INFORMATION

### ADVISE THE CUSTOMER

1. Keep the air filters clean. The heating system will operate better, more efficiently and more economically.
2. Arrange the furniture and drapes so that the supply air registers and the return air grilles are unobstructed.
3. Close doors and windows. This will reduce the heating load on the system.
4. Avoid excessive use of kitchen exhaust fans.
5. Do not permit the heat generated by television, lamps or radios to influence the thermostat operation.
6. Except for the mounting platform, keep all combustible articles 3 feet from the furnace and vent system.
7. **IMPORTANT:** Replace all blower doors and compartment covers after servicing the furnace. Do not operate the unit without all panels and doors securely in place.
8. Explain the advantages of continuous fan operation to the customer.

## ANNUAL INSPECTION

- The furnace should operate for many years without excessive scale build-up in the flue passageways. However, it is recommended that a qualified installer, service agency, or the gas supplier annually inspect the flue passageways, the vent system and the main burners for continued safe operation. Pay particular attention to deterioration from corrosion or other sources.
- **IMPORTANT:** It is recommended that at the beginning and at approximately half way through the heating season, a visual inspection be made of the main burner flames for the desired flame appearance by a qualified installer, service agency or the gas supplier. If the flames are distorted and/or there is evidence of back pressure, check the vent and inlet air system for blockage. If there is carbon and scale in the heat exchanger tubes, the heat exchanger assembly should be replaced.
- **IMPORTANT:** It is recommended that at the beginning of the heating season, the flame sensor be cleaned with fine steel wool or Scotch Bright Pad by a qualified installer, service agency or the gas supplier.
- **IMPORTANT:** It is recommended that at the beginning of the heating season, the condensate trap be inspected for debris or blockage. A blocked condensate trap can cause water to back up into the primary heat exchanger and lead to nuisance tripping of the overtemperature switches.
- **IMPORTANT:** It is recommended that at the beginning of the heating season, the condensate neutralizer if used be replaced by a qualified installer, service agency or the gas supplier.
- **IMPORTANT:** It is recommended that an annual inspection and cleaning of all furnace markings be made to assure legibility. Attach a replacement marking, which can be obtained through the distributor, if any are found to be illegible or missing.

### WARNING

**HOLES IN THE VENT PIPE OR HEAT EXCHANGER CAN CAUSE TOXIC FUMES TO ENTER THE HOME, RESULTING IN CARBON MONOXIDE POISONING OR DEATH. THE VENT PIPE OR HEAT EXCHANGER MUST BE REPLACED IF THEY LEAK.**

## REPLACEMENT PARTS

Please visit [www.rheemote.net](http://www.rheemote.net) for replacement parts information.

# DIAGNOSTICS AND TROUBLESHOOTING

Below are two lists; a list of standard operating codes and a list of fault codes. The fault code list provides diagnostic and troubleshooting information to help determine the problem and fix it. Standard operating codes are not fault codes and the presence of a standard operating code indicates a no-fault condition.

**NOTE:** Verify display orientation is correct before interpreting fault codes. Otherwise, the fault codes may be upside-down. If a fault code or operating code is not on these lists, the display may be upside-down.

**TABLE 19**  
R96V NORMAL OPERATION CODES

## NORMAL OPERATION CODES

Key

CODE DISPLAYED AT DUAL SEVEN-SEGMENT DISPLAY OF CONTROL	NAME
	<u>DESCRIPTION</u>

### NORMAL OPERATION CODE

<b>0</b>	<b>STANDBY MODE</b> <b>DESCRIPTION:</b> This code is displayed anytime there is no fault present and no thermostat call present. The furnace is idle.
<b>H or h</b>	<b>GAS HEAT MODE</b> <b>DESCRIPTION:</b> This code is displayed anytime there is a call for gas heat. The lower-case "h" is displayed when the thermostat is requesting low gas heat and the upper-case "H" is displayed when the thermostat is requesting high-stage gas heat.
<b>C or c</b>	<b>COOLING MODE</b> <b>DESCRIPTION:</b> This code is displayed anytime there is a call for cooling. The lower-case "c" is displayed when the thermostat is requesting low-stage cooling and the upper-case "C" is displayed when the thermostat is requesting high-stage cooling.
<b>HP or hP</b>	<b>HEAT-PUMP HEATING MODE</b> <b>DESCRIPTION:</b> This code is displayed anytime there is a call for heat-pump heat. The lower-case "hP" is displayed when the thermostat is requesting low-stage heat-pump heat and the upper-case "HP" is displayed when the thermostat is requesting high stage heat-pump heat.
<b>F</b>	<b>CONTINUOUS FAN MODE</b> <b>DESCRIPTION:</b> This code is displayed anytime there is a call for continuous fan from the thermostat.
<b>dF</b>	<b>DEFROST MODE</b> <b>DESCRIPTION:</b> This code indicates that the heat-pump is in defrost mode (dual-fuel systems only) and furnace is operating for defrost operation which is fixed at low-stage gas heating operation.
<b>Cd or cd</b>	<b>COOLING IN DE-HUMIDIFICATION MODE</b> <b>DESCRIPTION:</b> This code indicates that there is a both cooling and dehumidification demand present at the same time. When de-humidification is active, the cooling airflow will be reduced in order to allow water to accumulate on the condenser thereby removing humidity from the conditioned environment. The lower-case "cd" is displayed when the thermostat is requesting low-cooling with de-humidification and the upper-case "Cd" is displayed when the thermostat is requesting high-stage cooling with de-humidification.

**TABLE 20**  
R96V FAULT CODES WITH DESCRIPTIONS AND SOLUTIONS

**FAULT CODES**

Key

<b>FAULT CODE DISPLAYED AT DUAL SEVEN- SEGMENT DISPLAY OF CONTROL</b>	<b>DISPLAYED TEXT</b>
	<b>STATUS</b>
	<b>DESCRIPTION</b>
	<b>EXPECTED OPERATION</b>
	<b>CAUSE</b>
	<b>SOLUTION</b>

**FAULT CODES**

<b>d1</b>	<b>NO MODEL DATA</b>
	<b>STATUS:</b> This is a critical fault. The furnace will not operate in any mode.
	<b>DESCRIPTION:</b> This code is displayed anytime there is no model data at the furnace. The model data is electronically stored data that is used to define (among other things) blower operation. Without the model data, the furnace cannot function. Note that model data may be available even if there is no card attached to the furnace control. A missing memory card will display fault code "d4" if model data is available on the network.
	<b>EXPECTED OPERATION:</b> No operation (including thermostat) will be permitted without the model data. The model data defines the IBM (Indoor Blower Motor) speed-torque curve. Without this information, the IBM can not operate. Refer to the section of this manual titled "INTEGRATED FURNACE CONTROL" under the subsection titled "MEMORY CARD" for details on the hierarchy of use of multiple copies of model data and distribution (among other details) of model data.
	<b>CAUSE:</b> Typically, the memory card will be missing from the furnace. In most cases, the cause of this fault will be the loss or disconnection of the original memory card from the furnace control (or I.F.C.). When the furnace control (or I.F.C.) is replaced, the memory card must be saved and installed in the replacement control.
	<b>SOLUTION:</b> Replace the missing memory card into the connector labeled P6 on the furnace control (I.F.C.). If the original card can not be found, a replacement card can be ordered from ProStock. Be sure to order the correct memory card for the furnace. Note: Furnace power must be cycled off and then on again after replacing the card or the model data will not be read.
<b>d4</b>	<b>NO VALID MODEL DATA ON MEMORY CARD</b>
	<b>STATUS:</b> This is a non-critical fault. The furnace should operate in any mode.
	<b>DESCRIPTION:</b> The memory card inserted into the slot at position P6 of the furnace control is corrupt and can not be used OR there is no memory card installed at all. However, a valid copy of model data for the furnace still resides in the furnace microprocessor.
	<b>EXPECTED OPERATION:</b> model data from the memory card can not be used because it is invalid or not present at all. Operation should proceed as normal with this fault (d4) only being displayed during the standby mode.
	<b>CAUSE:</b> This fault is displayed when there is no information on the memory card (blank), the card is not present or the memory card has corrupted and can not be properly read.
	<b>SOLUTION:</b> Remove the memory card and replace with the <i>original</i> memory card from the furnace or the <i>correct</i> replacement memory card. <b>Never replace the memory card of a furnace with a memory card from another furnace or component (e.g. condenser or air handler). Doing so could result in improper operation of the blower which may cause damage to the heat exchanger. If the original memory card for the furnace control is available and working, it must be used.</b> A correct replacement memory card can be ordered from ProStock. Be sure to have the furnace model and serial number available when ordering.
<b>d6</b>	<b>HORSEPOWER CONFLICT ON MEMORY CARD</b>
	<b>STATUS:</b> This is a non-critical fault. The furnace should operate in any mode.
	<b>DESCRIPTION:</b> The horsepower reported by the motor does not match the horsepower stored in memory in the model data of the memory card. However, the model data stored on the microprocessor of the furnace control does match the attached motor.
	<b>EXPECTED OPERATION:</b> model data from the memory card can not be used because it is invalid. Operation should proceed as normal with this fault (d6) only being displayed during the standby mode.
	<b>CAUSE:</b> There are two possible causes for this fault: (1) The blower motor has recently been replaced and the wrong horsepower motor was used. (2) The memory card or furnace control has recently been replaced and the wrong card or replacement control was used.
	<b>SOLUTION:</b> Determine the correct motor and/or model data card for the furnace and replace the incorrect or damaged part with a new, correct part. <b>Never replace the memory card of a furnace with a memory card from another furnace or component (e.g. condenser or air handler). Doing so could result in improper operation of the blower which may cause damage to the heat exchanger. If the original memory card for the furnace control is available and working, it must be used.</b> A correct replacement memory card can be ordered from ProStock. Be sure to have the furnace model and serial number available when ordering.

**TABLE 20 (continued)**  
**R96V FAULT CODES WITH DESCRIPTIONS AND SOLUTIONS**

<b>10</b>	<b>ONE-HOUR LOCKOUT</b>
	<b>STATUS:</b> This is a critical fault. The furnace will not operate in gas heat modes but all other modes (e.g. cooling) should function.
	<b>DESCRIPTION:</b> This fault is displayed under the following conditions:
	1. When a failed ignition has occurred four times in a row, the control enters one-hour lockout and fault codes "10" and "11" will be displayed alternately at the seven-segment display. See fault code 11 for a description on expected operation, causes and solutions for this fault code.
	2. after declaring a Water Sensed condition (heating operation is shut down due to this fault) several times consecutively. When the control enters lockout the fault codes "59" (Water Sensed) and "10" (soft lockout) will be displayed alternately at the seven-segment display. See fault code 59 for a description on expected operation, causes and solutions for this fault code.
	3. While the control has entered a one-hour lockout after declaring a dead blower after the main limit control has been open for more than 150 seconds, the fault codes "61" (Non-operational blower) and "10" (soft lockout) will be displayed alternately at the seven-segment display. Note: the dead blower fault and associated one-hour lockout will occur up to four times in one heat call. Upon declaring this fault for the fourth time in one heat call, the control will enter hard lockout requiring manual reset of power to the furnace. See fault code 61 for a description on expected operation, causes and solutions for this fault code.
4. When IFC is in soft lockout and fault "93" is active, the fault code "93" is to be displayed alternately with the fault code "10" at the furnace seven-segment display. See fault code 93 for a description on expected operation, causes and solutions for this fault code.	
5. When flame is lost five times in a row, the control enters one-hour lockout and fault codes "10" and "13" will be displayed alternately at the IFC seven-segment display. See fault code 13 for a description on expected operation, causes and solutions for this fault code.	
6. While the control is in one-hour lockout due to an unexpected flame, the fault codes "14" (unexpected flame) and "10" (soft lockout) will be displayed alternately at the furnace seven-segment display. See fault code 14 for a description on expected operation, causes and solutions for this fault code.	
<b>11</b>	<b>FAILED IGNITION</b>
	<b>STATUS:</b> Up to three failed ignitions will not constitute a critical condition. Critical condition (with no heating operation) is only noted when the furnace has failed to ignite four or more times consecutively. After four failed ignition attempts, the IFC enters one-hour lockout and the dual faults "11" and "10" are alternately displayed at the IFC's seven-segment display.
	<b>DESCRIPTION:</b> This fault is displayed at the furnace control after the first failed ignition attempt. It continues to be displayed until successful ignition or the furnace control has failed to ignite four consecutive times. After four attempts, the status of the fault is elevated to "10" and the furnace control (or I.F.C.) reacts as described under description for the fault code "10". Note: This fault will not be displayed to the homeowner on communicating systems unless it occurs at least three times within a single heat call. It will not be displayed to the homeowner after the first or even second failure. However, it will be displayed in the active fault screen of thermostat immediately after the first failure (and all subsequent failures) during a single heat call. Further, this fault (11) will only be logged into the fault buffer one time. It will not log more than once in the buffer.
	<b>EXPECTED OPERATION:</b> After the first failed ignition attempt, the fault ("11") is displayed and the inducer will complete a 20 second post-purge followed by a second ignition attempt. This cycle will be repeated until gas heat is established or until the fourth failed ignition attempt. After the fourth failed attempt, the furnace control (IFC) will proceed to one-hour lockout.
	<b>CAUSE:</b> There can be several causes for a failed ignition attempt(s). The most common are: (1) The flame sense rod is unable to sense flame. It may need cleaning or may not be properly connected. (2) The gas valve may be turned off. (3) The igniter is not working properly. It may not be properly connected or the spark location may not be correct. (4) The furnace control may not be working properly and may need to be replaced. (5) The flame may not be properly spreading from the first burner to the last.
	<b>SOLUTION:</b> The solution will depend on the cause. Solutions to noted causes (1) through (5) above are: (1) Clean or replace the flame sense rod or check all connections and wire between the rod and the furnace control (or I.F.C.). Make sure furnace ground is properly connected. (2) Turn the valve on. (3) Replace or reposition the igniter or check all connections and wire between the igniter and the furnace control (or I.F.C.). (4) Replace the furnace control. (5) Check the manifold pressure during ignition. For natural gas it should be approx. 3.5" wc and for LP gas it should be approx. 10" wc. If manifold pressure is good, watch the burner during ignition. If the first burner lights, but the second, third and so on do not light, the burner may need to be replaced.

**TABLE 20 (continued)**  
**R96V FAULT CODES WITH DESCRIPTIONS AND SOLUTIONS**

<b>12</b>	<b>LOW FLAME SENSE</b>
	<p><b>STATUS:</b> The status of this fault is non-critical and furnace operation will continue as normal in heating (and all other) mode(s). If flame sense is low, the furnace control (or I.F.C.) may soon no longer be able to properly sense the flame and status of the problem may be elevated to the level of fault code "13" or fault "11" (if flame can not be sensed at all).</p>
	<p><b>DESCRIPTION:</b> The flame sense current from the flame sense rod at the furnace control (or I.F.C.) is weak or marginal at best.</p>
	<p><b>EXPECTED OPERATION:</b> All operation (including gas heat) will proceed as normal with only the fault code ("12") displayed at the furnace control (I.F.C.) and "LO FLAME SENSE" displayed in the fault area of a communicating thermostat.</p>
	<p><b>CAUSE:</b></p> <p>(1) The most common cause for low flame sense during heat operation is that the flame sense rod may need cleaning or may not be properly connected or wiring between the rod and the furnace control may be shorted or opened.</p> <p>(2) Another cause for low flame may be an improperly mounted or poorly grounded flame sensor.</p>
	<p><b>SOLUTION:</b></p> <p>(1) Clean or replace the flame sense rod or check all connections and wire between the rod and the furnace control (or I.F.C.).</p> <p>(2) Reinstall or replace flame sensor and check wiring and connections. Also make sure the furnace is properly grounded.</p>
<b>13</b>	<b>FLAME LOST AFTER ESTABLISHED</b>
	<p><b>STATUS:</b> Flame loss is not a critical fault. Subsequent ignition attempts will follow and normal operation should resume. However, a lost flame can often be followed by failed ignition attempts then a one-hour lockout. Once the status has reached one-hour lockout, the fault condition is critical (although attempts at ignition will be made again after the 1 hour lockout).</p>
	<p><b>DESCRIPTION:</b> After a successful ignition trial, the flame (which was properly sensed) is no longer sensed. This can happen any time after successful ignition while a valid heat call is present.</p>
	<p><b>EXPECTED OPERATION:</b> When flame is lost, the fault code ("13") is immediately displayed at the IFC SSD's. The IBM (Indoor Blower Motor) is energized (if it was not already) at the correct speed (based on the demand from the thermostat) and completes a 90 second blower off delay. The IDM (Induced Draft Motor) remains energized at the most recent speed (based on the demand from the thermostat or as required for ignition cycle) for a 20 second post-purge. After both the post-purge and blower off delay are complete, the fault code ("13") is removed and a new attempt at ignition is made. Often, the new ignition attempt will fail and operation will proceed as though a failed ignition has occurred from that point (see fault code "11").</p> <p>Note: This fault will not be displayed to the homeowner on communicating systems unless it occurs at least three times within a single heat call. It will not be displayed to the homeowner after the first or even second failure. However, it will be displayed in the active fault screen of the thermostat immediately after the first failure (and all subsequent failures) during a single heat call. Further, this fault (13) will only be logged into the fault buffer one time. It will not log more than once in the buffer.</p>
	<p><b>CAUSE:</b></p> <p>(1) The most common cause for low flame sense during heat operation is that the flame sense rod may need cleaning or may not be properly connected or wiring between the rod and the furnace control may be shorted or opened.</p> <p>(2) Another cause for low flame may be an improperly mounted or poorly grounded flame sensor.</p> <p>(3) Flame pattern may be unstable.</p>
	<p><b>SOLUTION:</b></p> <p>(1) Clean or replace the flame sense rod or check all connections and wire between the rod and the furnace control (or I.F.C.).</p> <p>(2) Reinstall or replace flame sensor and check wiring and connections. Also make sure the furnace is properly grounded.</p> <p>(3) Check that all burner assembly components are properly installed. Check for good seals between the burner and blower compartments. Insure that the combustion door gasket is in place and the door is properly installed and sealed.</p>
<b>14</b>	<b>FLAME PRESENT WITH GAS VALVE OFF</b>
	<p><b>STATUS:</b> This is an extremely critical fault and should rarely (if ever) be seen in the field. The furnace will not operate with this fault present.</p>
	<p><b>DESCRIPTION:</b> This fault indicates flame is present when it should not be. Flame is seen to be present when the gas valve is supposed to be off.</p>
	<p><b>EXPECTED OPERATION:</b> When unexpected flame is sensed, the IBM (Indoor Blower Motor) is energized at maximum heat speed and IDM (Induced Draft Motor) is energized at high speed. Both will remain energized until the fault is cleared. Response to any thermostat call is not permitted until the fault is cleared. Note that the gas valve circuit should not have been energized when the unexpected flame was sensed. When the condition causing the fault is cleared, the IDM will complete a 20 second post-purge and the IBM will complete a 90 second blower off-delay. The control will then enter a one-hour lockout and display the fault codes "10" (one-hour lockout) and "14" (unexpected flame) alternately for the duration of the one-hour lockout. Operation is returned to normal after the lockout period.</p>
	<p><b>CAUSE:</b></p> <p>(1) Field mis-wiring of 24VAC to the gas valve main solenoid.</p> <p>(2) Faulty gas valve stuck in the "OPEN" position.</p> <p>(3) Faulty furnace control (signal improperly sensed when it should not be sensed at all).</p>
	<p><b>SOLUTION:</b></p> <p>(1) Wire properly.</p> <p>(2) Replace gas valve.</p> <p>(3) Replace furnace control.</p>

**TABLE 20 (continued)**  
**R96V FAULT CODES WITH DESCRIPTIONS AND SOLUTIONS**

<b>MAIN LIMIT OPEN</b>	
<b>22</b>	<b>STATUS:</b> This is a critical fault. The furnace will not operate in gas heat modes but all other modes (e.g. cooling) should function.
	<b>DESCRIPTION:</b> The main limit has opened or is sensed to be opened. This normally means that the temperature inside the heat exchanger area has gone above a certain predetermined critical value and heating operation is not permitted until the limit cools to within normal parameters.
	<b>EXPECTED OPERATION:</b> When the main limit opens, the IBM (Indoor Blower Motor) will be energized at maximum heat speed. The gas valve circuit is de-energized (if it was energized) until the fault is cleared and the IDM (Induced Draft Motor) is energized at high speed and remains energized until the fault has cleared (limit has closed back). Response to thermostat cooling and fan calls will take place as normal. When the fault has cleared, the IBM will remain energized for the 90 second blower off delay period. If the limit control was opened for less than 150 seconds (2m:30sec), operation will proceed as normal after the post purge and blower off delays. However, if the limit is opened for more than 150 seconds, the control will declare a dead (non-functional) blower and proceed to a one-hour lockout and will alternately display fault codes "10" (one-hour lockout) and "61" dead blower at the furnace seven-segment display. Operation will proceed as described under fault code "61".
	<b>CAUSE:</b> (1) No airflow (2) Insufficient airflow (3) Faulty limit control (4) Loose or faulty wiring. (5) Dead (non-functional) blower. (6) Input too high
	<b>SOLUTION:</b> (1) Check for proper blower operation. Is the blower turning during heat (or any other) mode? If not, a blower motor fault should also be present. Check the wiring to the motor then check the motor. It may need replacing. (2) Check ductwork and filters. Determine the static pressure and make sure it is not above the published values for the furnace. Check the rate and outlet air temperature at high and low-fire heat (use the test mode dipswitches SW2-2 and SW2-3) and compare to the nameplate maximum values. Also, perform the calibration cycle again (if the SA sensor is installed) by cycling power to the furnace. (3) Replace the limit control. (4) Check wiring and connections. Replace and/or repair as necessary. (5) See Fault Code 61 for description, causes, operation and solutions. (6) Insure properly sized burner orifices are installed. Check the manifold pressure at high fire and compare to the nameplate values. Adjust as needed.
	<b>HALC OPEN</b>
<b>23</b>	<b>STATUS:</b> This is a critical fault. The furnace will not operate in gas heat modes but all other modes (e.g. cooling) should function.
	<b>DESCRIPTION:</b> This fault is displayed when the IFC does not sense continuity between pins 3 and 5 of connector P1 on the furnace control. Note: The fault code exists in the list of fault codes but the furnace as currently configured does not include an HALC control. There is a jumper wire in place of the control and, when the furnace control displays this fault, it generally means that the jumper wire is not making connection between the two pins on the control.
	<b>EXPECTED OPERATION:</b> When the circuit has been opened, the IBM (Indoor Blower Motor) is energized at maximum heating speed. The gas valve circuit is de-energized (if it was energized) and the IDM (Induced Draft Motor) is energized at high speed for 20 seconds after the fault is sensed. Response to thermostat cooling calls will take place as normal with IBM energizing at the higher of the two blower speeds (high heat or cool) when a call for cooling is also present. When the fault is cleared, the IBM will remain energized for the 90 second blower off-delay period.
	<b>CAUSE:</b> No continuity between pins 3 and 5 of connector P1 on the furnace control. <b>SOLUTION:</b> (1) Repair the jumper between pins 3 and 5 of connector P1 on the furnace control.
<b>LINE AND NEUTRAL REVERSED OR POOR GROUND</b>	
<b>26</b>	<b>STATUS:</b> This is a critical fault. The furnace will not operate in gas heat or any other modes.
	<b>DESCRIPTION:</b> This fault code is an indication that line voltage and neutral are reversed to the furnace control or may also be an indication of a grounding issue. No operation is not allowed to proceed until the problem is corrected.
	<b>EXPECTED OPERATION:</b> No heating or cooling operation will take place.
	<b>CAUSE:</b> (1) Line and neutral to the furnace have been interchanged at the furnace. (2) Line voltage and neutral have been interchanged at the disconnect or at the breaker box. (3) Furnace control cannot properly sense ground.
	<b>SOLUTION:</b> (1) Check voltage with meter and reverse line and neutral if necessary. (2) Check voltage with meter and reverse line and neutral if necessary. (3) Check ground wire inside furnace cabinet is attached to sheet metal, verify ground to furnace cabinet and at breaker box.

**TABLE 20 (continued)**  
**R96V FAULT CODES WITH DESCRIPTIONS AND SOLUTIONS**

<b>30</b>	<b>OPEN FUSE</b>
	<b>STATUS:</b> This is a critical fault. The furnace will not operate in any mode.
	<b>DESCRIPTION:</b> The fuse has been opened. This usually occurs when there is a 24VAC short to common or ground on the low-voltage side of the transformer.
	<b>EXPECTED OPERATION:</b> The fault code is displayed and no other operation can take place.
	<b>CAUSE:</b> An electrical short from low voltage (24VAC) to ground or common has occurred.
	<b>SOLUTION:</b> Repair the short circuit condition and replace fuse.
<b>OVER-TEMPERATURE SWITCH (ROLL-OUT) OPEN</b>	
<b>33</b>	<b>STATUS:</b> This is a critical fault. The furnace will not operate in gas heat modes but all other modes (e.g. cooling) should function.
	<b>DESCRIPTION:</b> The Manually Reset Limit Control (M.R.L.C.) is also known by the name "Rollout Limit". There can be several on any given furnace. When one or more of these limits open, they must be manually pushed back to the closed position (hence the name; <i>Manually Reset</i> ) to force the acknowledgement of a critical fault. This fault will occur when flames have rolled out of the normal area in the heat exchanger and into the burner compartment. This fault should rarely (if ever) be seen in the field and indicates a very serious problem that must be repaired before furnace operation can continue.
	<b>EXPECTED OPERATION:</b> When the MRLC (Manually Reset Limit Control) circuit has been opened, the IBM (Indoor Blower Motor) is energized at maximum heating speed. The gas valve circuit is de-energized (if it was energized) and the IDM (Induced Draft Motor) is energized at high speed. Response to thermostat cooling calls will take place as normal with IBM energizing at the higher of the two blower speeds (high heat or cool) when a call for cooling is also present. When the fault is cleared, the IDM will remain energized for a 20 second post-purge and the IBM will remain energized for the user-selected blower off-delay period.
	<b>CAUSE:</b> (1) Insufficient venting through either the inlet or exhaust. (2) Loose or faulty wiring. (3) Unstable flame pattern.
	<b>SOLUTION:</b> (1) Check that the pressure switch(es) have not been welded closed or bypassed. Check that the inducer is operating at the proper rpm. Insure that the venting does not exceed the maximum specified lengths. Check for obstructions in combustion venting. Check that all gaskets between the inducer and center panel / heat exchanger are properly installed and sealed. (2) Check wiring and connections. Replace and/or repair as necessary. (3) Check that all burner assembly components are properly installed. Check that all seals between the burner and blower compartments are tight. Insure that the door seals are in place and that the burner door is properly installed and does not leak. Check to make sure that the heat exchanger has not been damaged; i.e.: crushed tubes, breached collector box and etc.
<b>LOW PRESSURE SWITCH CLOSED, INDUCER OFF</b>	
<b>44</b>	<b>STATUS:</b> This is a critical fault. The furnace will not operate in gas heat modes but all other modes (e.g. cooling) should function if present simultaneously with a heating call (e.g. defrost call in dual-fuel mode).
	<b>DESCRIPTION:</b> The low pressure control (or switch) should not be closed when the inducer is not running. If it is, this is a sign of a serious condition. The switch may be welded closed or purposely bypassed in the field. Before any heat cycle can begin, the pressure switch is tested to make sure that it is opened. The switch is ignored except in gas heating modes.
	<b>EXPECTED OPERATION:</b> There will be no other operation than displaying of the fault code and diagnostic messages to the homeowner and technician. The fault code is only present during a heat call <i>before</i> pre-purge begins.
	<b>CAUSE:</b> (1) Faulty switch. (2) Pressure switch physically bypassed in the field. (3) Loose or faulty wiring. (4) Abnormally high negative pressure present on vent system without inducer running.
	<b>SOLUTION:</b> (1) Replace low pressure control (switch). (2) Remove bypass and restore correct operation. Determine reason for bypass (e.g. vent length too long) and correct issue. Notify homeowner and proper authorities of illegale tampering if necessary. (3) Check wiring and connections. Replace and/or repair as necessary. (4) Check for proper venting and terminations as defined in the furnace installation instructions.

**TABLE 20 (continued)**  
**R96V FAULT CODES WITH DESCRIPTIONS AND SOLUTIONS**

<b>LOW PRESSURE SWITCH OPEN, INDUCER ON HIGH SPEED</b>	
<b>45</b>	<p><b>STATUS:</b> This is a critical fault. The furnace will not operate in gas heat modes but all other modes (e.g. cooling) should function if present simultaneously with a heating call (e.g. defrost call in dual-fuel mode).</p> <p><b>DESCRIPTION:</b> This fault indicates that the low pressure switch is open <i>when the inducer is energized at high speed</i>. The switch must close after the inducer is energized and before the ignition sequence can begin. The switch is ignored except in heating modes.</p> <p><b>EXPECTED OPERATION:</b> (1) <b>DISPLAYED BEFORE HEAT IS ESTABLISHED:</b> The IBM (Indoor Blower Motor) will not be energized. The fault code will not be displayed until the IDM (Induced Draft Motor) has been energized for a minimum of ten seconds. The IDM will remain energized at the high speed (high speed is default pre-purge speed) for a period of five minutes after the beginning of the pre-purge attempt. After five minutes, the IDM is de-energized and second attempt at pre-purge is made (as long as the heat call is still present). This cycle is repeated indefinitely until either the pressure switch closes or the heat call is lost. (2) <b>DISPLAYED AFTER HEAT IS ESTABLISHED</b> - If this fault is displayed <i>after</i> heat is established, the gas valve will be de-energized, the IBM will be energized (if not already energized) at the correct heat speed (determined by the firing rate required by the thermostat) and the IDM will remain energized at high speed. The IBM will complete a 90 second blower off-delay and the IDM will complete a 20 second post-purge (at high speed). After these delays, a new attempt at ignition will be made provided the call for heat is still present.</p>
	<p><b>CAUSE:</b></p> <ol style="list-style-type: none"> <li>(1) Blockage or improper termination in either the inlet or exhaust vents.</li> <li>(2) The flue vent length and/or number of elbows exceeds the maximum number specified.</li> <li>(3) Faulty or disconnected inducer.</li> <li>(4) Faulty control board (inducer relay).</li> <li>(5) Loose or faulty wiring.</li> <li>(6) Disconnected, blocked, split or cut pressure switch hoses.</li> <li>(7) Wind gusts (sporadic).</li> <li>(8) Faulty pressure switch.</li> </ol>
	<p><b>SOLUTION:</b></p> <ol style="list-style-type: none"> <li>(1) Check the vent system for blockage and proper termination and repair as necessary.</li> <li>(2) Check the specification sheets and/or installation instructions. Remove excess venting.</li> <li>(3) Repair or replace inducer and/or inducer wiring and/or electrical connections.</li> <li>(4) Replace control board.</li> <li>(5) Check wiring and connections. Replace and/or repair as necessary.</li> <li>(6) Replace hoses as necessary.</li> <li>(7) Insure proper termination and determine if high altitude kit may be necessary (see item 4)</li> <li>(8) Replace the pressure switch.</li> </ol>
<b>LOW PRESSURE SWITCH OPEN, INDUCER ON LOW SPEED</b>	
<b>46</b>	<p><b>STATUS:</b> This is a critical fault. The furnace will not operate in gas heat modes but all other modes (e.g. cooling) should function if present simultaneously with a heating call (e.g. defrost call in dual-fuel mode).</p> <p><b>DESCRIPTION:</b> This fault indicates that the low pressure switch is open <i>when the inducer is energized at low speed</i>. Since the furnace only ignites at high fire, this condition should never be seen except after the blower on delay period of the ignition cycle and only after the furnace attempt to switch to low stage heating. The switch is ignored except in heating modes.</p> <p><b>EXPECTED OPERATION:</b> This fault is displayed only after heat is established and switched to low fire with the IBM (Indoor Blower Motor) energized at low speed. When this fault is displayed the gas valve will be de-energized, the IBM will remain energized at the low heat speed and the IDM (Induced Draft Motor) will remain energized at the low speed. The IBM will complete the user-selected blower off-delay (at low speed) and the IDM will complete a 20 second post-purge (at low speed). After these delays, a new attempt at ignition will be made provided the call for heat is still present.</p>
	<p><b>CAUSE:</b></p> <ol style="list-style-type: none"> <li>(1) Blockage or improper termination in either the inlet or exhaust vents.</li> <li>(2) The flue vent length and/or number of elbows exceeds the maximum number specified.</li> <li>(3) Faulty or disconnected inducer.</li> <li>(4) Faulty control board (inducer relay).</li> <li>(5) High altitude kit not installed in areas of high elevation.</li> <li>(6) Loose or faulty wiring.</li> <li>(7) Disconnected, blocked, split or cut pressure switch hoses.</li> <li>(8) Wind gusts (sporadic).</li> <li>(9) Faulty pressure switch.</li> </ol>
	<p><b>SOLUTION:</b></p> <ol style="list-style-type: none"> <li>(1) Check the vent system for blockage and proper termination and repair as necessary.</li> <li>(2) Check the specification sheets and/or installation instructions. Remove excess venting.</li> <li>(3) Repair or replace inducer and/or inducer wiring and/or electrical connections.</li> <li>(4) Replace control board.</li> <li>(5) Check elevation of the installation and consult the specifications for the furnace to determine if a high altitude kit is needed. Install proper kit as necessary.</li> <li>(6) Check wiring and connections. Replace and/or repair as necessary.</li> <li>(7) Replace hoses as necessary.</li> <li>(8) Insure proper termination and determine if high altitude kit may be necessary (see item 4)</li> <li>(9) Replace the pressure switch.</li> </ol>

**TABLE 20 (continued)**  
**R96V FAULT CODES WITH DESCRIPTIONS AND SOLUTIONS**

<b>55</b>	<b>HIGH PRESSURE SWITCH CLOSED, INDUCER OFF</b>
	<p><b>STATUS:</b> This is a critical fault. The furnace will not operate in gas heat modes but all other modes (e.g. cooling) should function if present simultaneously with a heating call (e.g. defrost call in dual-fuel mode).</p> <p><b>DESCRIPTION:</b> The high pressure control (or switch) should not be closed when the inducer is not running. If it is, this is a sign of a serious condition. The switch may be welded closed or purposely bypassed in the field. Before any heat cycle can begin, the pressure switch is tested to make sure that it is opened. The switch is ignored except in gas heating modes.</p>
	<p><b>EXPECTED OPERATION:</b> There will be no other operation than displaying of the fault code and diagnostic messages to the homeowner and technician. The fault code is only present during a heat call before pre-purge begins.</p>
	<p><b>CAUSE:</b></p> <ol style="list-style-type: none"> <li>(1) Faulty switch.</li> <li>(2) Pressure switch physically bypassed in the field.</li> <li>(3) Loose or faulty wiring.</li> <li>(4) Abnormally high negative pressure present on vent system without inducer running.</li> </ol> <p><b>SOLUTION:</b></p> <ol style="list-style-type: none"> <li>(1) Replace high pressure control (switch).</li> <li>(2) Remove bypass and restore correct operation. Determine reason for bypass (e.g. vent length too long) and correct issue. Notify homeowner and proper authorities of illegal tampering if necessary.</li> <li>(3) Check wiring and connections. Replace and/or repair as necessary.</li> <li>(4) Check for proper venting and terminations as defined in the furnace installation instructions.</li> </ol>
<b>57</b>	<b>HIGH PRESSURE SWITCH OPEN, INDUCER ON HIGH SPEED</b>
	<p><b>STATUS:</b> This is a critical fault. The furnace will not operate in gas heat modes but all other modes (e.g. cooling) should function if present simultaneously with a heating call (e.g. defrost call in dual-fuel mode). If this fault is experienced during high heat operation and the low pressure switch remains engaged, the furnace will switch to low fire heat and continue to run (if possible) to try to satisfy the thermostat.</p> <p><b>DESCRIPTION:</b> This fault indicates that the high pressure switch is open when the inducer is energized at high speed. This fault can be displayed any time during the heat call except during low heat call and only <i>after</i> the pre-purge and blower on delays are complete.</p>
	<p><b>EXPECTED OPERATION:</b> (1) <b>DISPLAYED BEFORE HEAT IS ESTABLISHED:</b> The IBM (Indoor Blower Motor) will not be energized. The fault code will not be displayed until the IDM (Induced Draft Motor) has been energized for a minimum of ten seconds. The IDM will remain energized at the high speed (high speed is default pre-purge speed) for a period of five minutes after the beginning of the pre-purge attempt. After five minutes, the IDM is de-energized and second attempt at pre-purge is made (as long as the heat call is still present). This cycle is repeated indefinitely until either the pressure switch closes or the heat call is lost. (2) <b>DISPLAYED AFTER HEAT IS ESTABLISHED</b> - If this fault is displayed after heat is established, the IDM will remain energized at high speed and the firing rate will drop to low stage provided the low pressure switch remains closed. The IBM will energize at, or switch to, the low-fire rate (also provided the low pressure switch remains closed). Low heat is provided until the heat call ends or the high pressure switch closes. If the high pressure switch closes, the heat rate and blower speed will be adjusted to the correct (higher) rate required by the thermostat and the IDM will remain energized at high speed. If the low pressure switch also will not remain closed, operation will be as described under fault code # 46 ("LPC OPEN") above.</p>
	<p><b>CAUSE:</b></p> <ol style="list-style-type: none"> <li>(1) Blockage or improper termination in either the inlet or exhaust vents.</li> <li>(2) The flue vent length and/or number of elbows exceeds the maximum number specified.</li> <li>(3) Faulty or disconnected inducer.</li> <li>(4) Faulty control board (inducer relay).</li> <li>(5) High altitude kit not installed in areas of high elevation.</li> <li>(6) Loose or faulty wiring.</li> <li>(7) Disconnected, blocked, split or cut pressure switch hoses.</li> <li>(8) Wind gusts (sporadic).</li> <li>(9) Faulty pressure switch.</li> </ol> <p><b>SOLUTION:</b></p> <ol style="list-style-type: none"> <li>(1) Check the vent system for blockage and proper termination and repair as necessary.</li> <li>(2) Check the specification sheets and/or installation instructions. Remove excess venting.</li> <li>(3) Repair or replace inducer and/or inducer wiring and/or electrical connections.</li> <li>(4) Replace control board.</li> <li>(5) Check elevation of the installation and consult the specifications for the furnace to determine if a high altitude kit is needed. Install proper kit as necessary.</li> <li>(6) Check wiring and connections. Replace and/or repair as necessary.</li> <li>(7) Replace hoses as necessary.</li> <li>(8) Insure proper termination and determine if high altitude kit may be necessary (see item 4)</li> <li>(9) Replace the pressure switch.</li> </ol>
<b>58</b>	<b>WATER CIRCUIT OPEN</b>
	<p><b>STATUS:</b> This is a critical fault experienced by the furnace. The furnace will not operate in gas heat modes but all other modes (e.g. cooling) should function if a call is present.</p> <p><b>DESCRIPTION:</b> The IFC cannot detect electrical continuity between pins 1 and 2 of connector P4 of the furnace control. The IFC looks for continuity between these pins to determine if the water sensors (2) are present in the circuit. When both sensors are present and properly connected and wiring is not damaged, there should be electrical continuity between these pins.</p>
	<p><b>EXPECTED OPERATION:</b> No gas heating operation can proceed and the fault is displayed. All other modes (e.g. cooling) of operation should operate as normal.</p>
	<p><b>CAUSE:</b></p> <ol style="list-style-type: none"> <li>(1) Wiring has been damaged between the control or sensor.</li> <li>(2) Connection of P4 at the IFC or at the water sensors is not properly made.</li> <li>(3) Water sensor has been removed.</li> </ol> <p><b>SOLUTION:</b></p> <ol style="list-style-type: none"> <li>(1) Repair or replace wiring.</li> <li>(2) Repair connections or replace wiring or sensors or controls as necessary.</li> <li>(3) Replace missing water sensor.</li> </ol>

**TABLE 20 (continued)**  
**R96V FAULT CODES WITH DESCRIPTIONS AND SOLUTIONS**

<b>WATER SENSED</b>	
<b>59</b>	<b>STATUS:</b> This is a critical fault experienced by the furnace. The furnace will not operate in gas heat modes but all other modes (e.g. cooling) should function if a call is present.
	<b>DESCRIPTION:</b> The IFC has detected current flowing from pin(s) 1 and/or 2 of connector P4 of the furnace control. The IFC looks for current flow from these pins to determine if water is present in the collector box. When water is present, the sensor will pass a small amount of electrical current to the sheet metal of the furnace. This current flow will notify the IFC that water is present. Note: The condition must be present continuously for at least ten seconds before the IFC will declare the fault.
	<b>EXPECTED OPERATION:</b> No gas heating operation can proceed and the fault is displayed. All other modes (e.g. cooling) of operation should operate as normal.
	<b>CAUSE:</b> (1) A blocked condensate drain or the drain trap has become blocked and cannot allow condensate water to flow properly. (2) Wiring to the sensors has been damaged and exposed wiring is touching the furnace sheet metal. (3) Water sensor has been removed from the collector box with wires still attached and the metal probe is touching the sheet metal portion of the furnace.
	<b>SOLUTION:</b> (1) Remove/Repair drain blockage. (2) Replace/Repair wiring between IFC and both sensors. (3) Return sensor(s) to proper location in the collector box.
<b>BLOWER FAULT - BLOWER CAN STILL RUN</b>	
<b>60</b>	<b>STATUS:</b> This is a non-critical fault experienced by the furnace. All operations (including thermostat calls) should continue as normal with no perceivable difference in operation.
	<b>DESCRIPTION:</b> A blower fault which is non-critical allows the blower to continue to run but at less-than-optimal conditions.
	<b>EXPECTED OPERATION:</b> All (including thermostat) operation should continue as normal. Blower operation may be slightly compromised but will continue.
	<b>CAUSE:</b> (1) The blower has hit the maximum speed or torque limit specified by the manufacturer or is running at the temperature limit because the static pressure is too high.
	<b>SOLUTION:</b> (1) The static pressure is too high because the ductwork is improperly designed or is restricted for some other reason or the filter needs cleaning or replacing. Remove the obstruction or repair the duct so that static pressure does not exceed published values in the specification sheets or installation instructions.
<b>BLOWER FAULT - MOTOR CANNOT RUN</b>	
<b>61</b>	<b>STATUS:</b> This is a critical fault. The furnace will not operate in any mode.
	<b>DESCRIPTION:</b> The blower has failed critically or there is a critical motor fault - such as thermal limit trip that prevents the blower motor from running.
	<b>EXPECTED OPERATION:</b> If the furnace was in heating operation when this fault occurred, blower operation will immediately stop and the furnace will shut down normally with post-purge at the correct speed. After the post purge (or immediately if no heat call was present), no other operation (including thermostat calls) will occur until this fault is cleared. This fault may be displayed in heating or cooling modes and may also be displayed in heating mode after the main limit control has been opened four times consecutively for more than 150 seconds (2m:30sec) each time. If this happens, the IFC determines that the motor and/or blower is not functional and enters a hard lockout condition requiring repair of the blower/motor and manual reset of power to the furnace.
	<b>CAUSE:</b> (1) The motor has tripped on thermal limit because of a restriction or bearing failure. (2) The motor Power Factor Correction (P.F.C.) choke is faulty and needs replacing. (3) The furnace model data is faulty or corrupted. (4) Wiring to the motor and/or P.F.C. has become compromised. (5) The blower wheel has become damaged or is not properly attached to the motor shaft. (6) The motor has failed catastrophically.
	<b>SOLUTION:</b> (1) Remove obstruction or replace motor. (2) Replace the Power Factor Correction choke. (3) Replace the furnace memory card with the correct replacement part from ProStock. (4) Inspect and replace or repair wiring and/or connectors to the motor and/or P.F.C. as necessary. (5) Replace the blower wheel and/or attach the blower wheel to the motor shaft properly. (6) Replace the motor.

**TABLE 20 (continued)**  
**R96V FAULT CODES WITH DESCRIPTIONS AND SOLUTIONS**

	<b>BLOWER CUTBACK</b>
	<p><b>STATUS:</b> This is a non-critical fault experienced by the furnace. All operations (including thermostat calls) should continue as normal with no perceivable difference in operation.</p> <p><b>DESCRIPTION:</b> The blower motor is operating at the highest rpm or torque that specifications allow but the application requires more torque or speed in order to get the desired airflow under the current static pressure conditions. The motor will continue to operate because internal software will prevent operation above the permitted range. However, a fault is sent to the furnace control (or I.F.C.) from the motor.</p> <p><b>Note:</b> This fault will not be displayed after the first three minutes of blower operation after power reset. Further, this fault will not be logged in the fault buffer or fault history after the first hour of operation and will only be logged into the fault buffer a maximum of one time. This code (66) indication is intended as a tool to notify the installer of inadequate airflow due to excessive static pressure in the duct of the system. The code is not intended to be a fault code. It is merely an operating indicator.</p> <p><b>EXPECTED OPERATION:</b> All (including thermostat) operation should continue as normal. Blower operation may be slightly compromised but will continue.</p> <p><b>CAUSE:</b>                      (1) The blower has hit the maximum speed or torque limit specified by the manufacturer because the static pressure is too high.</p> <p><b>SOLUTION:</b>                      (1) The static pressure is too high because the ductwork is improperly designed or is restricted for some other reason or the filter needs cleaning or replacing. Remove the obstruction or repair the duct so that static pressure does not exceed published values in the specification sheets or installation instructions for the furnace.</p>
	<b>NO BLOWER COMMUNICATIONS</b>
	<p><b>STATUS:</b> This is a critical fault. The furnace will not operate in any mode.</p> <p><b>DESCRIPTION:</b> The furnace control (I.F.C.) can not communicate with the blower motor.</p> <p><b>EXPECTED OPERATION:</b> If the furnace was in heating operation when this fault occurred, the gas valve will immediately close (flame will be lost), IBM (Indoor Blower Motor) operation will immediately stop and the furnace will shut down normally (except without IBM operation) with IDM (Induced Draft Motor) post-purge at the correct speed. After the post purge (or immediately if no heat call was present), no other operation (including thermostat calls) will occur until this fault is cleared.</p> <p><b>CAUSE:</b>                      (1) The wires between the blower motor have been disconnected or there is a poor connection.                      (2) There is no line voltage to the motor.                      (3) The furnace model data is faulty or corrupted.                      (4) The motor has failed catastrophically.</p> <p><b>SOLUTION:</b>                      (1) Check wiring, connectors and terminals - repair or replace as necessary.                      (2) Check line voltage wiring, connectors and terminals to the Power Factor Correction choke and ECM motor. Repair and replace as necessary.                      (3) Replace the furnace memory card with the correct replacement part from ProStock.                      (4) Replace the motor.</p>
	<b>INTERNAL CONTROL FAULT DETECTED</b>
	<p><b>STATUS:</b> This is a critical fault. The furnace will not operate in any mode of operation.</p> <p><b>DESCRIPTION:</b> This is a severe fault that should rarely (if ever) be discovered in the field. It is an indicator of an internal microprocessor fault on the furnace control (or I.F.C.) or voltage applied to the main gas valve solenoid when there should be none.</p> <p><b>EXPECTED OPERATION:</b> If possible, if the furnace was in heating operation when this fault occurred, the gas valve will immediately close (flame will be lost), IBM (Indoor Blower Motor) operation will immediately stop and the furnace will shut down normally (except without IBM operation) with IDM (Induced Draft Motor) post-purge at the correct speed. After the post purge (or immediately if no heat call was present), no other operation (including thermostat calls) will occur until this fault is cleared. However, this fault may also indicate an internal microprocessor failure. This may mean that the heat call will not end as expected and that all outputs will be de-energized and gas valve closed immediately when the fault is sensed.</p> <p><b>CAUSE:</b>                      (1) 24VAC or similar voltage applied to the main gas valve solenoid circuit unexpectedly.                      (2) Furnace control software test failure - failed furnace control (or I.F.C.).</p> <p><b>SOLUTION:</b>                      (1) Check for miswiring in the furnace.                      (2) Replace the furnace control (or I.F.C.).</p>
	<b>REMOTE FAULTS RESET PERFORMED</b>
99	This is a notification that fault codes in the fault buffer have been reset.

# DIAGNOSTICS AND TROUBLESHOOTING

## LOCKOUT AND REPLACING THE FURNACE CONTROL

All lockout conditions can be cleared immediately provided that the original fault causing the lockout is cleared and power to the unit is cycled off and then back on again or (soft lockout only) if a heat call is cycled off for greater than 2 seconds but less than 20 seconds.

The furnace control will not initiate a heat cycle during any lockout condition. A call for compressor or continuous fan will generally be responded to but control will display the lockout error fault code instead of the “C” (for compressor) or “F” (for Continuous fan).

### FIVE-MINUTE LOCKOUT

A five minute “soft” lockout will be initiated if the low pressure switch fails to close after 60 seconds of continuous inducer operation at the beginning of a normal heat cycle (pressure switch proving period). The seven-segment display will display the appropriate fault. Lockout will automatically be reset after five minutes.

### ONE-HOUR LOCKOUT

A one hour “soft” lock out will be initiated when:

- Flame has not been detected after four ignition trials.
- Flame has been lost for five times in one heat call.
- Undesired flame has been detected. The one-hour period will commence after flame is no longer detected.
- Dead Blower has been detected (main limit circuit open for more than 150 seconds)
- When voltage has unexpectedly been detected on the gas valve circuit and voltage goes away when inducer is shut off.
- If a *Water Sensed* condition is detected once during heat call (heat cycle terminated in response to fault) and then clears and then is detected again within 5 minutes of the next heat attempt (same heat call).

The seven-segment display will alternately display “10” and the code number for the fault causing the lockout. Lockout will automatically be reset after one hour.

### HARD LOCKOUT

Three conditions shall cause a hard lockout:

1. The control senses an unspecified internal fault. Fault code “93” is set and displayed. This lockout condition cannot be reset by cycling the heat call.
2. Voltage is detected unexpectedly on the gas valve contacts (welded relay) and will not clear by cycling

the inducer . Fault code “93” is set and displayed. This lockout condition cannot be reset by cycling the heat call.

3. The furnace control will declare that the blower motor is inoperable (dead) if the main limit control has been open for more than 150 seconds. Gas heating is terminated. However, the control continues to try to operate heating for up to four attempts in case the blower motor starts working again. If a dead blower has been declared four times in one heat call, the furnace control enters a hard-lockout. Fault code “61” is set and displayed. This lockout condition **CAN** be reset by cycling the heat call.

### REPLACING THE FURNACE CONTROL

In the event that the furnace control must be replaced, the memory card must be removed from the original furnace control and retained with the furnace. A plastic tether with a note wrapped around the tether is used to remind the technician not to remove the card from the furnace. Use this card to insert into the memory card connector labeled P6 of the replacement control board. Failure to save and connect the memory card properly to the replacement control may result in no operation or undesired operation of the furnace.

When replacing the furnace control, be sure to match the dipswitch settings of the original control on the replacement.

**DO NOT CUT THE PLASTIC WIRE TIE USED AS A TETHER TO THE ATTACHED MEMORY CARD. DOING SO WILL DEFEAT THE PURPOSE OF RETAINING THE MEMORY CARD – WHICH COULD LEAD TO A LOSS OF CRITICAL DATA NECESSARY TO OPERATE THE FURNACE. THE CARD MUST STAY WITH THE FURNACE – EVEN WHEN THE FURNACE CONTROL (IFC) MUST BE REPLACED. NEVER USE A CONTROL BOARD TAKEN FROM ANOTHER FURNACE AS A REPLACEMENT CONTROL FOR THIS FURNACE. FURNACE CONTROLS TAKEN FROM OTHER FURNACES MAY CONTAMINATE THE SYSTEM WITH THE WRONG MODEL DATA WHICH CAN ONLY BE FIXED BY REPLACING THE MEMORY CARD WITH THE ORIGINAL MEMORY CARD FROM THE ORIGINAL FURNACE OR A REPLACEMENT MEMORY CARD DESIGNED FOR THE ORIGINAL FURNACE.**

### DIAGNOSING BLOWER MOTOR ISSUES

If the main circulating blower motor will not operate when it should, there are some different methods for diagnosing the problem.

# DIAGNOSTICS AND TROUBLESHOOTING

## DIAGNOSING BLOWER MOTOR ISSUES

### 1. MOTOR POWER AND COMMUNICATIONS ISSUES (FAULT CODE “68”)

Is the motor communicating properly with the furnace control? If not, the fault code “68” will be displayed any time there is a call for cooling, heating or continuous fan. To determine the cause of this issue, follow these steps:

- A. Remove the line voltage connector from the motor. This is the 5-pin connector. With the door switch closed, verify that there is 115-120VAC between pins 4 and 5 of the connector (see photos in Figure 59B). If no line voltage is detected, check the wiring and correct the issue. Line voltage should be present at these pins any time the furnace is powered. Make sure that the pins of the connector are fully seated in the housing to ensure good contact with the connection at the motor. When voltage is confirmed at these pins, replace the connector on the motor.
- B. Remove the motor control connector from the furnace control at P5 and apply 24VAC to pins 3 & 4 (see photo). With the door switch closed (motor powered) and 24VAC on pins 3 & 4, the motor should start operating at 75% of capacity. If the motor is operating at a good speed, it is likely not the motor that is the problem. If the motor is not operating, verify that the control wiring between the motor and furnace control (to P5) is good and that all the pins on both ends are fully seated. If the wiring connections looks good, and the motor still will not operate, the motor likely needs to be replaced.

**FIGURE 59**  
LINE VOLTAGE AND LOW VOLTAGE CONNECTIONS TO THE COMMUNICATING MOTOR

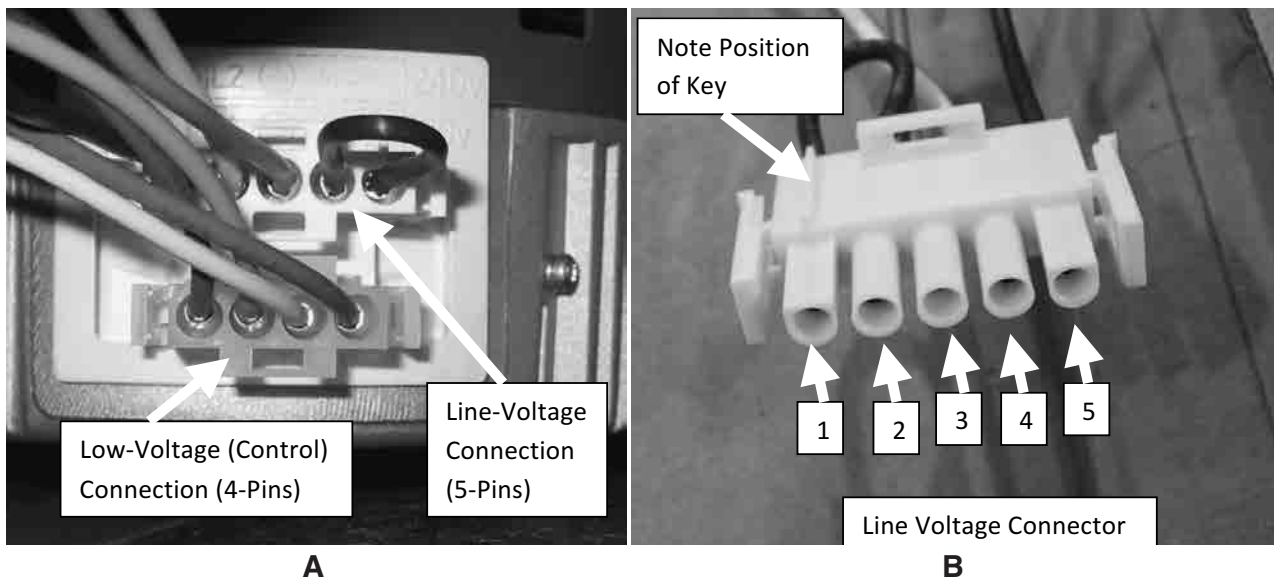

# DIAGNOSTICS AND TROUBLESHOOTING

## DIAGNOSING BLOWER MOTOR ISSUES

**FIGURE 60**  
LOW VOLTAGE CONNECTION PIN DETAIL

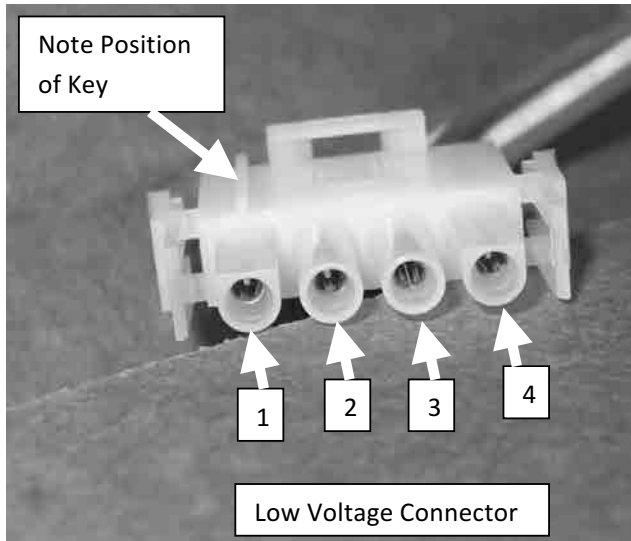

### 2. OVERSPEED OPERATION (CODE “66”)

Note: This code will only be displayed during the first three minutes of blower operation and then only if the call for fan is great enough to force the motor into speed limit.

- A. Is the duct work of the system restrictive or confined? Or, maybe many (or all) of the supply registers are closed in the duct system. If so, the motor may indicate that it is operating in power limit under certain conditions by displaying code “66”. Remove the restrictions or reconfigure the duct work to avoid this code.

- B. Is the motor set-screw not tightened to the motor shaft? This may cause erratic motor operation and cause the furnace to display a “66” fault code. Further, airflow will be low or air may not be moving at all.

### 3. INTERNAL ERROR – MOTOR UNABLE TO OPERATE (FAULT CODE “61”)

If the blower motor is able to communicate with the furnace control but is experiencing an internal issue – such as overheating, the fault code “61” will be displayed. Internal overloading may reset once the condition causing the problem has been removed. However, it is likely that the motor will need to be replaced.

- A. Is the motor wheel blocked by an obstruction? If so, the motor may be in locked-rotor state and the furnace control will report fault code “61”. Remove the obstruction and try to operate the motor again. If the motor continues to fail, it may be permanently damaged and may need to be replaced.
- B. Is the motor overheating? If so, it may report an overheat condition to the furnace control and the control will report fault code “61”. Determine the cause of overheating and repair. Try to operate the motor again. If the motor continues to fail, it may be permanently damaged and may need to be replaced.

### 4. INTERNAL ERROR – MOTOR ABLE TO OPERATE (FAULT CODE “60”)

This is a low-level fault that is not likely to be displayed often. Operation will continue as normal but fault code will be displayed. Long-term permanent damage to the motor is not expected.

# DIAGNOSTICS AND TROUBLESHOOTING

**FIGURE 61**  
**2-TAGE FURNACE TROUBLESHOOTING CHART**

## 2-STAGE COMMUNICATING INTEGRATED FURNACE CONTROL (IFC) DIAGNOSTIC CHART

**NOTE: Most failures are not due to the IFC. Double check all other possibilities, including the ground connection, before replacing the IFC. Be sure to note dip switch settings before troubleshooting.**

**START**

- 1) For communicating systems, Remove communications connections from the T-stat (E1, E2) and use a jumper wire between W1 & R also between R & W2 to set high stage gas heat. For legacy systems ensure W2 & W1 are properly connected and make sure both are energized w/ 240 AC after the heat call is placed.
- 2) Set FAN switch to "AUTO" on T-stat.
- 3) Set thermostat to call for heat (set temp. differential to greater than 10°F). (Comm. jumper W1 to R and W2 to R)
- 4) "H" should be displayed at "SSD's" and should be on steady, if flashing check dip switches (Item "1").

**KEY TO ABBREVIATIONS**  
ECM = Constant CFM Blowers. (Electronically commutated motor)  
TSTAT = Thermostat.  
IDM = Induced Draft Motor (or inducer).  
IFC = Integrated Furnace Control (or control board).  
PS = Pressure Switch(es).  
PFC = Power Factor Correction Choke.  
SE = Spark Electrode (s).  
SSD = Seven Segment Display of Furnace control  
COMM. = Communication.  
I&O = Installation & Operation Instructions Manual.

WARNING

HAZARDOUS VOLTAGE  
LINE VOLTAGE  
CONNECTIONS

DISCONNECT POWER BEFORE SERVICING.  
SERVICE MUST BE BY A TRAINED,  
QUALIFIED SERVICE TECHNICIAN.

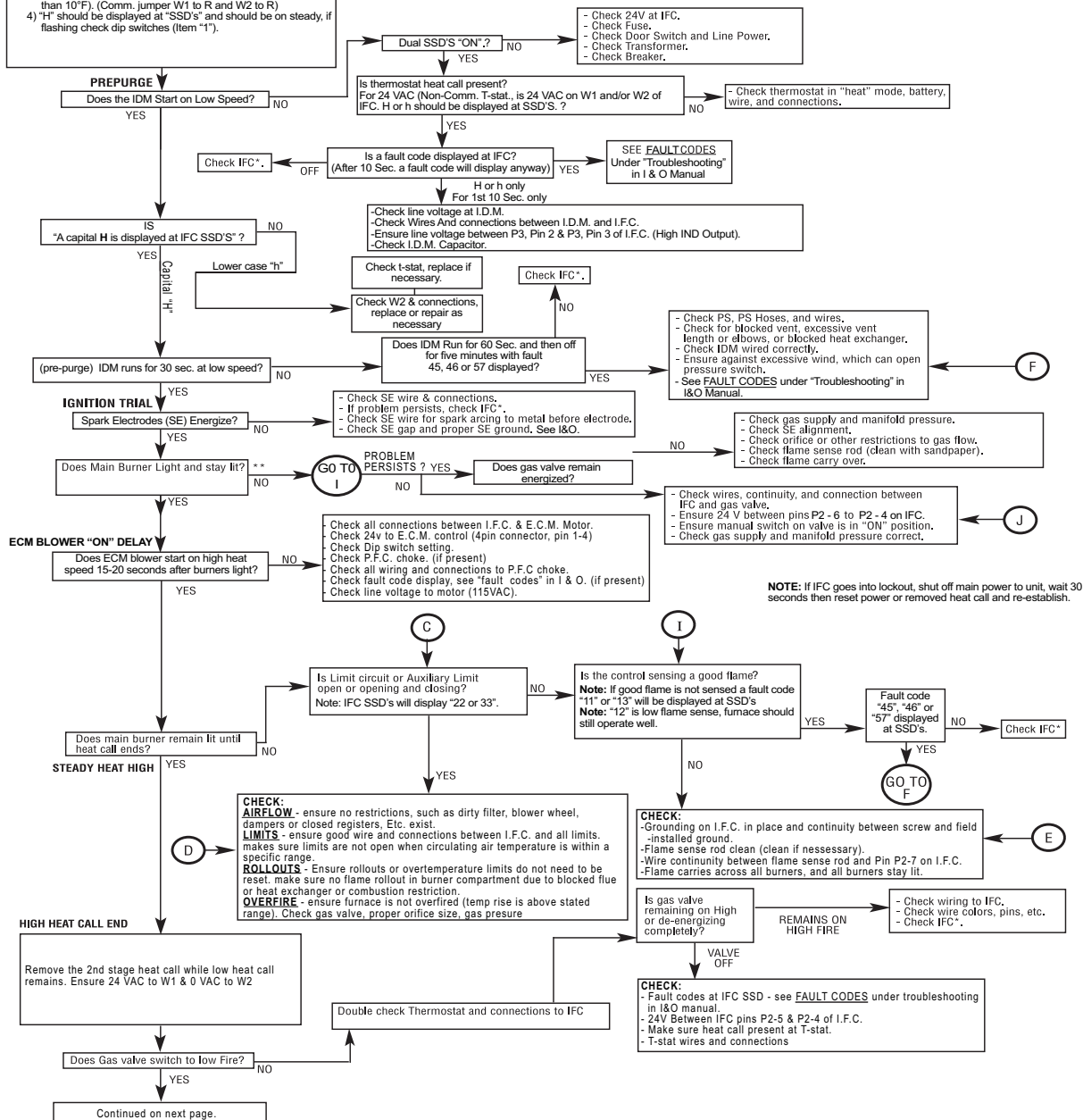

**FIGURE 61 (continued)**  
**2-TAGE FURNACE TROUBLESHOOTING CHART**

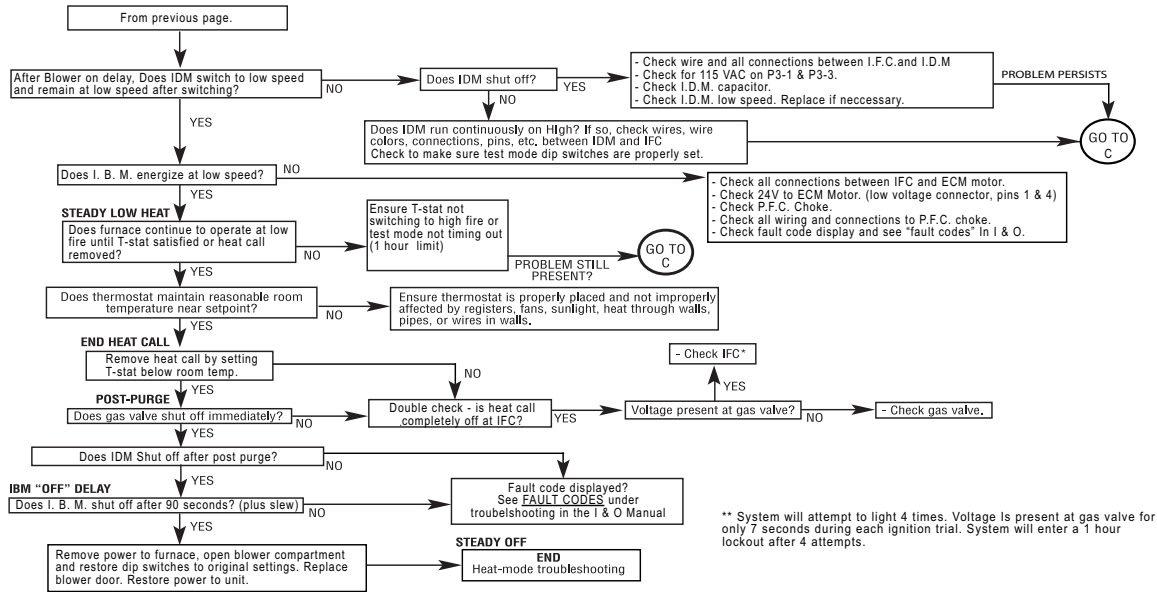

\*\* System will attempt to light 4 times. Voltage is present at gas valve for only 7 seconds during each ignition trial. System will enter a 1 hour lockout after 4 attempts.

REPEAT THIS SEQUENCE UNTIL TROUBLE- FREE OPERATION

ST-A1194-52-X0

**FIGURE 62**  
2-STAGE ECM FURNACE WIRING DIAGRAM

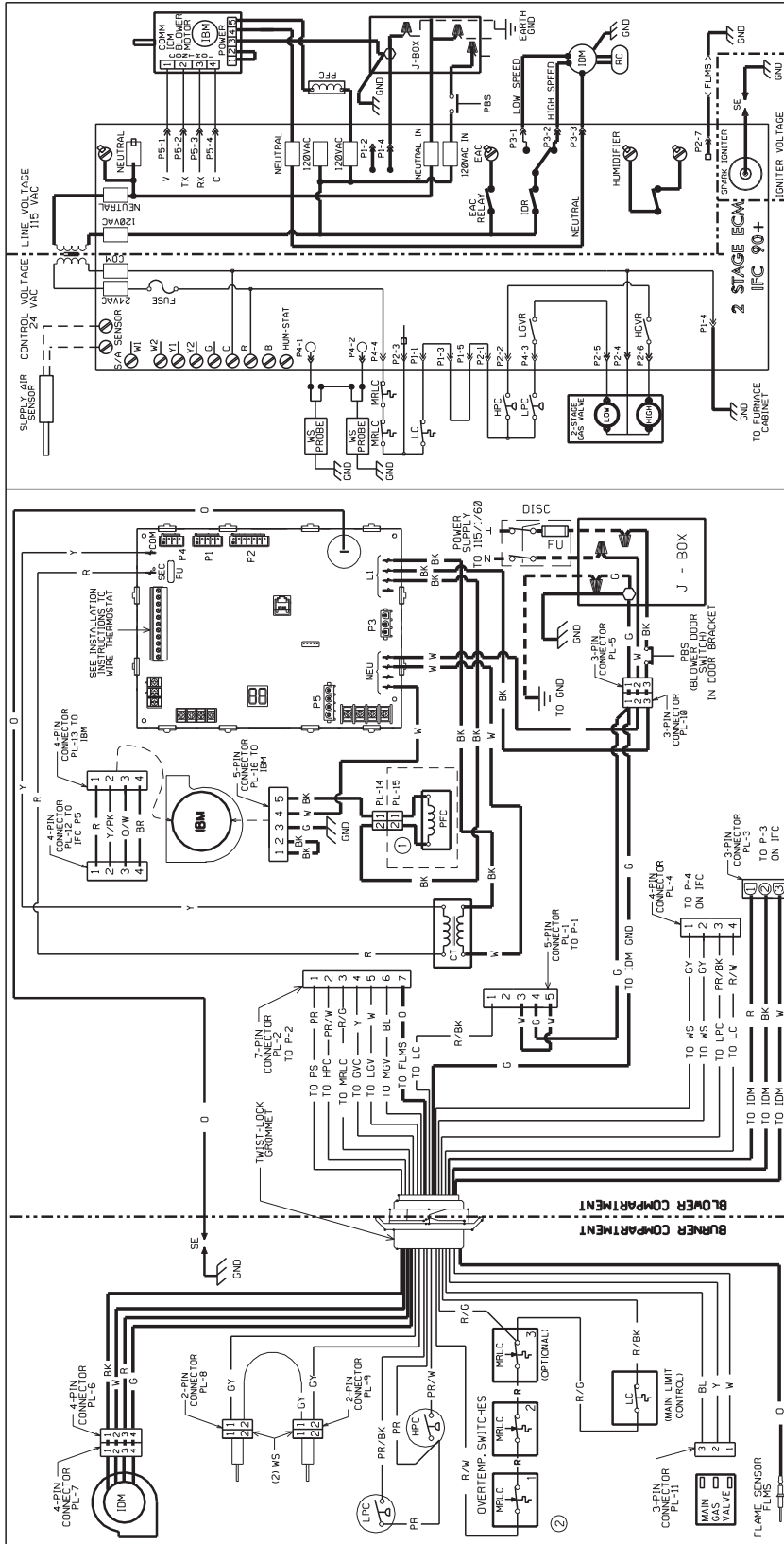

<p><b>COMPONENT CODE</b></p> <p>BL/R BLOWER RELAY C COMMON CC CONTACTOR CT CONTROL TRANSFORMER DISC DISCONNECT SWITCH EAC ELECT. AIR CLEANER OUTPUT FLMS FLAME SENSOR FIR FUSE GND GROUND GVC GAS VALVE COMMON GVR GAS VALVE RELAY HALC HEAT ASSISTED LIMIT CONTROL HCR HEAT/COOL RELAY HPC HIGH PRESSURE CONTROL HPC HIGH PRESSURE CONTROL HUM HUMIDIFIER OUTPUT IDM INDOOR BLOWER MOTOR INDUCED DRAFT MOTOR</p>	<p><b>COMPONENT CODE</b></p> <p>IFC INTEGRATED FURNACE CONT LFC LOW GAS VALVE CONTROL LGV LOW GAS VALVE M MAIN MC MEMORY CARD MGV MAIN GAS VALVE MRLC MAIN RESET LIMIT CONTROL NFC NEGATIVE PRESSURE CONT. NPS NEGATIVE PRESSURE CONT. PFC POWER FACTOR CHOKE PL PLUG PS PRESSURE SWITCH PWS PRESSURE SWITCH SE SPARK ELECTRODE TM THERMISTOR WS WATER SENSOR WIRE NUT</p>	<p><b>NOTES:</b></p> <p>① JUMPER USED IN PLACE OF PFC ON 1/2 HP MOTOR MODELS</p> <p>② TWO OR THREE MRLC SWITCHES MAY BE PRESENT DEPENDING ON MODEL.</p> <p>= CHASSIS GROUND = EARTH GROUND</p>	<p><b>WIRING INFORMATION</b></p> <p>LINE VOLTAGE -FACTORY STANDARD -FACTORY OPTION -FIELD INSTALLED LOW VOLTAGE -FACTORY STANDARD -FACTORY OPTION -FIELD INSTALLED REPLACEMENT WIRE -MUST BE THE SAME SIZE AND TYPE OF INSULATION AS ORIGINAL (105 C. MIN.) WARNING -CABINET MUST BE PERMANENTLY GROUNDED AND CONFORM TO I.E.C., N.E.C., C.E.C., NATIONAL WIRING REGULATIONS, AND LOCAL CODES AS APPLICABLE.</p>	<p><b>WIRE COLOR CODE</b></p> <p>0 --- ORANGE BR --- BROWN BL --- BLUE G --- GREEN GY --- GRAY PK --- PINK R --- RED W --- WHITE Y --- YELLOW</p> <p><b>ELECTRICAL WIRING DIAGRAM</b></p> <p>UPFLOW / DOWNFLOW - HORIZONTAL BLOWER INDUCED DRAFT TWO STAGE 90PLUS ECM GAS FIRED, FORCED AIR FURNACE</p>
---	--	--	--	---

