

# INSTALLATION INSTRUCTIONS

## AIR HANDLERS

FEATURING INDUSTRY STANDARD R-410A REFRIGERANT:  R-410A  
(-)H1P Standard Efficiency with Aluminum Coil



**RECOGNIZE THIS SYMBOL AS AN INDICATION OF IMPORTANT SAFETY INFORMATION!**

### **▲WARNING**

These instructions are intended as an aid to qualified licensed service personnel for proper installation, adjustment and operation of this unit. Read these instructions thoroughly before attempting installation or operation. Failure to follow these instructions may result in improper installation, adjustment, service or maintenance possibly resulting in fire, electrical shock, property damage, personal injury or death.



**ISO 9001:2008**

Certificate Number: 30164

**DO NOT DESTROY THIS MANUAL**

**PLEASE READ CAREFULLY AND KEEP IN A SAFE PLACE FOR FUTURE REFERENCE BY A SERVICEMAN**



# TABLE OF CONTENTS

<b>1.0</b>	<b>SAFETY INFORMATION</b>	<b>3</b>
<b>2.0</b>	<b>GENERAL INFORMATION</b>	<b>5</b>
2.1	Important Information About Efficiency and Indoor Air Quality	5
2.2	Receiving	6
2.3	Clearances	6
2.4	Model Number Explanation	7
2.4A	Available Models	8
2.5	Dimensions and Weights	9
<b>3.0</b>	<b>APPLICATIONS</b>	<b>10</b>
3.1	Vertical Upflow and Horizontal Left	10
3.2	Vertical Downflow and Horizontal Right	10
3.3	Installation in an Unconditioned Space	12
3.4	Installation in Mobile/Manufactured Homes	13
<b>4.0</b>	<b>ELECTRICAL WIRING</b>	<b>14</b>
4.1	Power Wiring	14
4.2	Control Wiring	14
4.2B	Thermostat Connections	15
4.3	Grounding	16
4.4	Electrical Wiring	16
4.5	Blower Motor Electrical Data	16
4.5	Blower Motor Electrical Data: (-)H1P	16
4.6	Copper Wire Size	16
4.7	Electric Heat Electrical Data	17
4.7A	Electric Heat Electrical Data: (-)H1P	17
4.7B	Heater Kit Supplemental Information	20
<b>5.0</b>	<b>AIRFLOW PERFORMANCE</b>	<b>21</b>
5.1	Airflow Operating Limits (-)H1P	21
5.2	240V Airflow Performance Data (-)H1P	22
<b>6.0</b>	<b>DUCTWORK</b>	<b>26</b>
<b>7.0</b>	<b>REFRIGERANT CONNECTIONS</b>	<b>26</b>
7.1	TEV Sensing Bulb	26
7.2	Orifice Size	
7.3	Condensate Drain Tubing	27
7.4	Duct Flanges	28
<b>8.0</b>	<b>AIR FILTER</b>	<b>28</b>
<b>9.0</b>	<b>SEQUENCE OF OPERATION</b>	<b>29</b>
9.1	Cooling	29
9.2	Heating (electric heat only)	29
9.3	Heating (heat pump)	29
9.4	Blower Time Delay (heating or cooling)	29
9.5	Defrost (defrost heat control)	29
9.6	Emergency Heat (heating heat pump)	30
9.7	Room Thermostat (anticipator setting)	30
<b>10.0</b>	<b>CALCULATIONS</b>	<b>30</b>
10.1	Calculating Temperature Rise	30
10.2	Calculating BTUH Heating Capacity	30
10.3	Calculating Airflow CFM	30
10.4	Calculating Correction Factor	30
<b>11.0</b>	<b>PRE-START CHECKLIST</b>	<b>31</b>
<b>12.0</b>	<b>MAINTENANCE</b>	<b>31</b>
12.1	Air Filter	31
12.2	Indoor Coil/Drain Pan/Drain Line	32
12.3	Blower Motor & Wheel	32
12.4	Lubrication	32
12.5	Blower Assembly Removal and Replacement	32
12.6	Motor Replacement	33
12.7	Blower Wheel Replacement	33
<b>13.0</b>	<b>REPLACEMENT PARTS</b>	<b>33</b>
<b>14.0</b>	<b>ACCESSORIES - KITS - PARTS</b>	<b>34</b>

**⚠ WARNING** (SEE SECTION 4.0: ELECTRICAL WIRING)

Disconnect all power to unit before installing or servicing. More than one disconnect switch may be required to de-energize the equipment. Hazardous voltage can cause severe personal injury or death.

**⚠ WARNING** (SEE SECTION 12.5: BLOWER ASSEMBLY REMOVAL & REPLACEMENT)

If removal of the blower assembly is required, all disconnect switches supplying power to the equipment must be de-energized and locked (if not in sight of unit) so the field power wires can be safely removed from the blower assembly. Failure to do so can cause electrical shock resulting in personal injury or death.

**⚠ WARNING**

Because of possible damage to equipment or personal injury, installation, service, and maintenance should be performed by a trained, qualified service personnel. Consumer service is recommended only for filter cleaning/replacement. Never operate the unit with the access panels removed.

## 1.0 SAFETY INFORMATION

**⚠ WARNING**

Duct leaks can create an unbalanced system and draw pollutants such as dirt, dust, fumes and odors into the home causing property damage. Fumes and odors from toxic, volatile or flammable chemicals, as well as automobile exhaust and carbon monoxide (CO), can be drawn into the living space through leaking ducts and unbalanced duct systems causing personal injury or death (see Figure 1).

- If air-moving equipment or ductwork is located in garages or off-garage storage areas - all joints, seams, and openings in the equipment and duct must be sealed to limit the migration of toxic fumes and odors including carbon monoxide from migrating into the living space.
- If air-moving equipment or ductwork is located in spaces containing fuel burning appliances such as water heaters or boilers - all joints, seams, and openings in the equipment and duct must also be sealed to prevent depressurization of the space and possible migration of combustion byproducts including carbon monoxide into the living space.

**⚠ WARNING**

These instructions are intended as an aid to qualified, licensed service personnel for proper installation, adjustment and operation of this unit. Read these instructions thoroughly before attempting installation or operation. Failure to follow these instructions may result in improper installation, adjustment, service or maintenance possibly resulting in fire, electrical shock, property damage, personal injury or death.

**⚠ WARNING** (SEE SECTION 3.2: VERTICAL DOWNFLOW)

The RXHB-17, RXHB-21 or RXHB-24 combustible floor base is required when some units with electric heat are applied downflow on combustible flooring. Failure to use the base can cause a fire resulting in property damage, personal injury or death. See **CLEARANCES** for units requiring a combustible floor base. See the accessory section in this manual for combustible floor base RXHB.

**⚠ WARNING** (SEE SECTION 4.3: GROUNDING)

The unit must be permanently grounded. Failure to do so can result in electrical shock causing personal injury or death.

**⚠ WARNING** (SEE SECTION 12.0: MAINTENANCE)

Units with circuit breaker(s) meet requirements as a service disconnect switch, however, if access is required to the line side (covered) of the circuit breaker, this side of the breaker(s) will be energized with the breaker(s) de-energized. Contact with the line side can cause electrical shock resulting in personal injury or death.

**⚠ WARNING** (SEE SECTION 5.0: DUCTWORK)

Do not, under any circumstances, connect return ductwork to any other heat producing device such as fireplace insert, stove, etc. Unauthorized use of such devices may result in fire, carbon monoxide poisoning, explosion, personal injury or property damage.

## **WARNING**

**PROPOSITION 65:** This appliance contains fiberglass insulation. Respirable particles of fiberglass are known to the State of California to cause cancer.

All manufacturer products meet current Federal OSHA Guidelines for safety. California Proposition 65 warnings are required for certain products, which are not covered by the OSHA standards.

California's Proposition 65 requires warnings for products sold in California that contain or produce any of over 600 listed chemicals known to the State of California to cause cancer or birth defects such as fiberglass insulation, lead in brass, and combustion products from natural gas.

All "new equipment" shipped for sale in California will have labels stating that the product contains and/or produces Proposition 65 chemicals. Although we have not changed our processes, having the same label on all our products facilitates manufacturing and shipping. We cannot always know "when, or if" products will be sold in the California market.

You may receive inquiries from customers about chemicals found in, or produced by, some of our heating and air-conditioning equipment, or found in natural gas used with some of our products. Listed below are those chemicals and substances commonly associated with similar equipment in our industry and other manufacturers.

- Glass Wool (Fiberglass) Insulation
- Carbon Monoxide (CO).
- Formaldehyde
- Benzene

More details are available at the websites for OSHA (Occupational Safety and Health Administration), at [www.osha.gov](http://www.osha.gov) and the State of California's OEHHA (Office of Environmental Health Hazard Assessment), at [www.oehha.org](http://www.oehha.org). Consumer education is important since the chemicals and substances on the list are found in our daily lives. Most consumers are aware that products present safety and health risks, when improperly used, handled and maintained.

## **WARNING** (SEE SECTION 12.6: MOTOR REPLACEMENT)

To avoid electrical shock which can result in personal injury or death, use only the screws furnished in the motor shell mounting holds. Screws are #8-18 x .25 in. long blunt nose thread forming. Screws longer than 1/4 in. may contact the motor winding.

## **WARNING** (SEE SECTION 7.0: AIR FILTER)

Do not operate the system without filters. A portion of the dust entrained in the air may temporarily lodge in the duct runs and at the supply registers. Any circulated dust particles could be heated and charred by contact with the air handler elements. This residue could soil ceilings, walls, drapes, carpets and other articles in the house.

Soot damage may occur with filters in place, when certain types of candles, oil lamps or standing pilots are burned.

## **WARNING**

The first 36 inches of supply air plenum and ductwork must be constructed of sheet metal as required by NFPA 90B. The supply air plenum or duct must have a solid sheet metal bottom directly under the unit with no openings, registers or flexible air ducts located in it. If flexible supply air ducts are used they may be located only in the vertical walls of a rectangular plenum, a minimum of 6 inches from the solid bottom. Metal plenum or duct may be connected to the combustible floor base, if not, it must be connected to the unit supply duct flanges such that combustible floor or other combustible material is not exposed to the supply air opening from the downflow unit. Exposing combustible (non-metal) material to the supply opening of a downflow unit can cause a fire resulting in property damage, personal injury or death.

### Exceptions to downflow warnings:

- Installations on concrete floor slab with supply air plenum and ductwork completely encased in not less than 2 inches of concrete (See NFPA 90B).

## **CAUTION** (SEE SECTION 3.3: HORIZONTAL)

Horizontal units must be configured for right hand air supply or left hand air supply. Horizontal drain pan must be located under indoor coil. Failure to use the drain pan can result in property damage.

## **CAUTION** (SEE SECTION 2.1: RECEIVING)

In compliance with recognized codes, it is recommended that an auxiliary drain pan be installed under all evaporator coils or units containing evaporator coils that are located in any area of a structure where damage to the building or building contents may occur as a result of an overflow of the coil drain pan or a stoppage in the primary condensate drain piping. See accessories for auxiliary horizontal overflow pan RXBM.

## **NOTICE**

When used in cooling applications, excessive sweating may occur when unit is installed in an unconditioned space. This can result in property damage.

## **NOTICE**

Improper installation, or installation not made in accordance with the Underwriters Laboratory (UL) certification or these instructions, can result in unsatisfactory operation and/or dangerous conditions and are not covered by the unit warranty.

## **NOTICE**

In compliance with recognized codes, it is recommended that an auxiliary drain pan be installed under all evaporator coils or units containing evaporator coils that are located in any area of a structure where damage to the building or building contents may occur as a result of an overflow of the coil drain pan or a stoppage in the primary condensate drain piping. See accessories section of these instructions for auxiliary horizontal overflow pan information (model RXBM).

## ⚠ NOTICE

Use of this air-handler during construction is not recommended. If operation during construction is absolutely required, the following temporary installation requirements must be followed:

Installation must comply with all Installation Instructions in this manual including the following items:

- Properly sized power supply and circuit breaker/fuse
- Air-handler operating under thermostatic control;
- Return air duct sealed to the air-handler;
- Air filters must be in place;
- Correct air-flow setting for application
- Removing the coil and storing it in a clean safe place is highly recommended until construction is completed and the outdoor unit is installed.
- Clean air-handler, duct work, and components including coil upon completion of the construction process and verify proper air-handler operating conditions according as stated in this instruction manual.
- NOTE: Electric strip heater elements tend to emit a burning odor for a few days if dust has accumulated during construction. Heater elements are easily damaged. Take great care when cleaning them. Low pressure compressed air is recommended for cleaning elements.

## 2.0 GENERAL INFORMATION

### 2.1 IMPORTANT INFORMATION ABOUT EFFICIENCY AND INDOOR AIR QUALITY

Central cooling and heating equipment is only as efficient as the duct system that carries the cooled or heated air. To maintain efficiency, comfort and good indoor air quality,

**FIGURE 1**  
MIGRATION OF DANGEROUS SUBSTANCES, FUMES, AND ODORS INTO LIVING SPACES

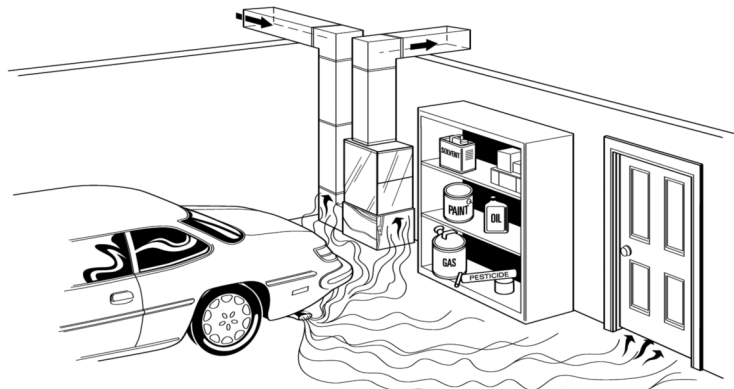

Adapted from *Residential Duct Diagnostics and Repair*, with permission of Air Conditioning Contractors of America (ACCA).

## ⚠ WARNING



### Carbon Monoxide (CO) Poisoning Can Cause Severe Injury or Death.

Carbon Monoxide from the exhaust of motor vehicles and other fuel burning devices can be drawn into the living space by the operation of the central heating and air conditioning system.

Exhaust from motor vehicles, generators, garden tractors, mowers, portable heaters, charcoal and gas grills, gasoline powered tools, and outdoor camping equipment contains carbon monoxide, a poisonous gas that can kill you. You cannot see it, smell it, or taste it.

- Do NOT operate an automobile or any engine in a garage for more than the few seconds it takes to enter or exit the garage.
- Do NOT operate any fuel-burning device in an enclosed or partly enclosed space, or near building windows, doors or air intakes.

The U.S. Consumer Product Safety Commission (CPSC) and Health Canada recommend the installation of UL or CSA certified Carbon Monoxide Alarm(s) in every home.

## ⚠ WARNING

Duct leaks can create an unbalanced system and draw pollutants such as dirt, dust, fumes and odors into the home causing property damage. Fumes and odors from toxic, volatile or flammable chemicals, as well as automobile exhaust and carbon monoxide (CO), can be drawn into the living space through leaking ducts and unbalanced duct systems causing personal injury or death (see Figure 1).

- If air-moving equipment or ductwork is located in garages or off-garage storage areas - all joints, seams, and openings in the equipment and duct must be sealed to limit the migration of toxic fumes and odors including carbon monoxide from migrating into the living space.
- If air-moving equipment or ductwork is located in spaces containing fuel burning appliances such as water heaters or boilers - all joints, seams, and openings in the equipment and duct must also be sealed to prevent depressurization of the space and possible migration of combustion byproducts including carbon monoxide into the living space.

## ⚠ NOTICE

Improper installation, or installation not made in accordance with the Underwriters Laboratory (UL) certification or these instructions, can result in unsatisfactory operation and/or dangerous conditions and are not covered by the unit warranty.

it is important to have the proper balance between the air being supplied to each room and the air returning to the cooling and heating equipment.

Proper balance and sealing of the duct system improves the efficiency of the heating and air conditioning system and improves the indoor air quality of the home by reducing the amount of airborne pollutants that enter homes from spaces where the ductwork and/or equipment is located. The manufacturer and the U.S. Environmental Protection Agency's Energy Star Program recommend that central duct systems be checked by a qualified contractor for proper balance and sealing.

## NOTICE

**In compliance with recognized codes, it is recommended that an auxiliary drain pan be installed under all evaporator coils or units containing evaporator coils that are located in any area of a structure where damage to the building or building contents may occur as a result of an overflow of the coil drain pan or a stoppage in the primary condensate drain piping. See accessories section of these instructions for auxiliary horizontal overflow pan information (model RXBM).**

## 2.2 RECEIVING

Immediately upon receipt, all cartons and contents should be inspected for transit damage. Units with damaged cartons should be opened immediately. If damage is found, it should be noted on the delivery papers, and a damage claim filed with the last carrier.

- After unit has been delivered to job site, remove carton taking care not to damage unit.
- Check the unit rating plate for unit size, electric heat, coil, voltage, phase, etc. to be sure equipment matches what is required for the job specification.
- Read the entire instructions before starting the installation.
- Some building codes require extra cabinet insulation and gasketing when unit is installed in attic applications.
- If installed in an unconditioned space, apply caulking around the power wires, control wires, refrigerant tubing and condensate line where they enter the cabinet. Seal the power wires on the inside where they exit conduit opening. Caulking is required to pre-vent air leakage into and condensate from forming inside the unit, control box, and on electrical controls.
- Install the unit in such a way as to allow necessary access to the coil/filter rack and blower/control compartment.
- Install the unit in a level position to ensure proper condensate drainage. Make sure unit is level in both directions within 1/8".
- Install the unit in accordance with any local code which may apply and the national codes. Latest editions are available from: "National Fire Protection Association, Inc., Batterymarch Park, Quincy, MA 02269." These publications are:
  - ANSI/NFPA No. 70-(Latest Edition) National Electrical Code.
  - NFPA90A Installation of Air Conditioning and Ventilating Systems.
  - NFPA90B Installation of warm air heating and air conditioning systems.
- The equipment has been evaluated in accordance with the Code of Federal Regulations, Chapter XX, Part 3280.

## 2.3 CLEARANCES

- All units are designed for "0" inches clearance to combustible material on all cabinet surfaces.
- Units with electric heat require a one inch clearance to combustible material for the first three feet of supply plenum and ductwork.
- Some units require a combustible floor base depending on the heating kW. The following table should be used to determine these requirements.

Model Cabinet Size	17	21	24
Maximum Model Designation kW	15	18	20

Additionally, if these units are installed down-flow, a combustible floor base is required. See Accessories for Combustible Floor Base RXHB-XX.

Units with electric heating kW equal to or less than the values listed in the table do not require a combustible floor base.

- Vertical units require clearance on at least one side of the unit for electrical connections. Horizontal units require clearance on either top or bottom for electrical connections. Refrigerant and condensate drain connections are made on the front of the unit.
- All units require 24 inches minimum access to the front of the unit for service.
- These units may be installed in either ventilated or nonventilated spaces.

## 2.4 MODEL NUMBER EXPLANATION

**FIGURE 2**  
MODEL NUMBER EXPLANATION

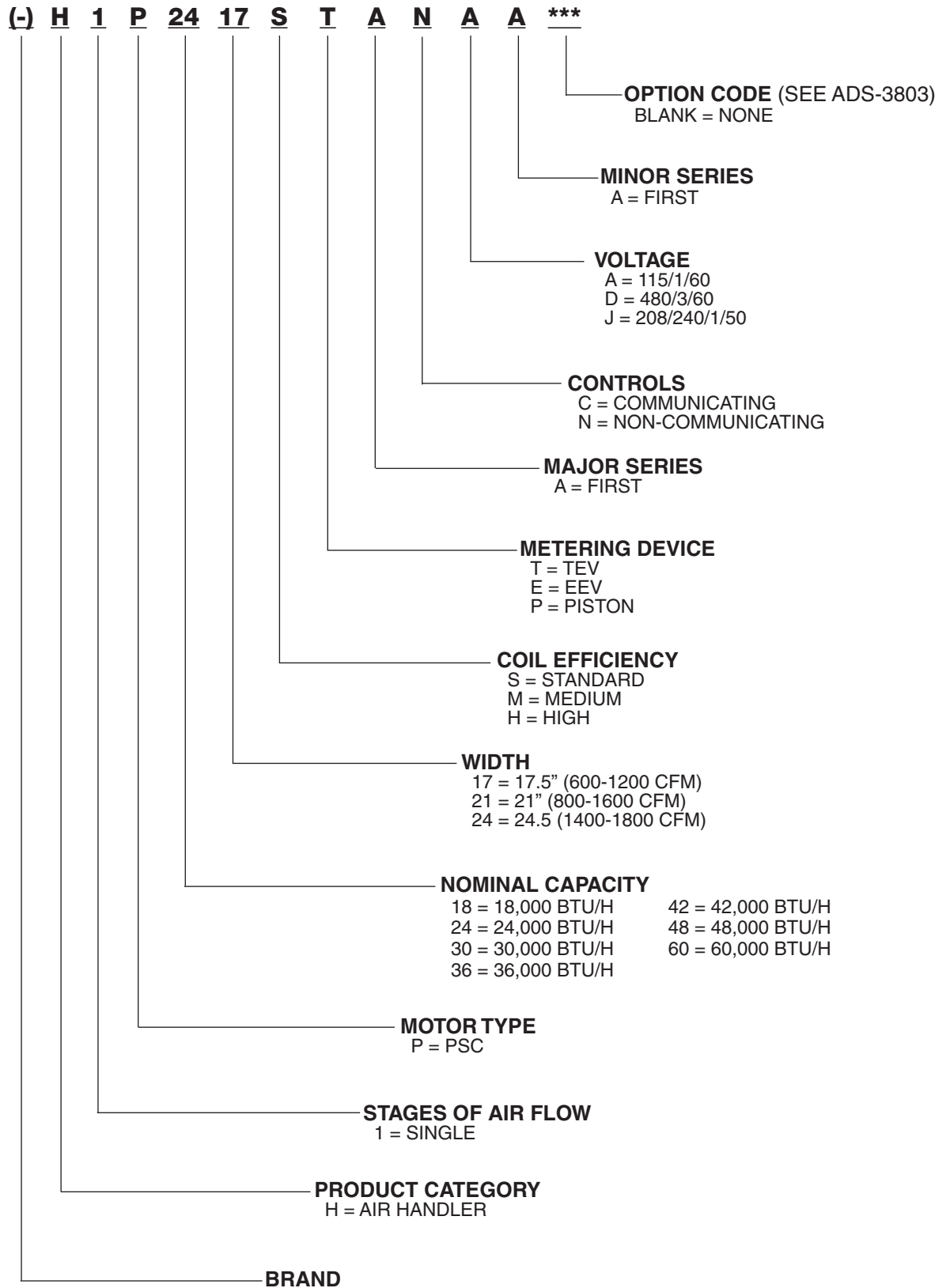

## 2.4A AVAILABLE MODELS

### AVAILABLE MODELS AT A VOLTAGE

(-)H1P1817STANAA
(-)H1P2417STANAA
(-)H1P3017STANAA
(-)H1P3617STANAA
(-)H1P4221STANAA
(-)H1P4821STANAA

### AVAILABLE MODELS AT J VOLTAGE

(-)H1P1817STANJA
(-)H1P2417STANJA
(-)H1P3017STANJA
(-)H1P3617STANJA
(-)H1P3621STANJA
(-)H1P4221STANJA
(-)H1P4821STANJA
(-)H1P4824STANJA
(-)H1P6024STANJA

### AVAILABLE MODELS AT D VOLTAGE

(-)H1P3617STANDA
(-)H1P4221STANDA
(-)H1P4821STANDA
(-)H1P4824STANDA
(-)H1P6024STANDA

#### Notes:

- Supply circuit protective devices may be fuses or “HACR” type circuit breakers.
- Largest motor load is included in single circuit and multiple circuit 1.
- If non-standard fuse size is specified, use next size larger fuse size.
- J Voltage (208/240V) single phase air handler is designed to be used with single or three phase 208/240V power. In the case of connecting 3-phase power to the air handler terminal block, bring only two leads to the terminal block. Cap, insulate and fully secure the third lead.
- The air handlers are shipped from the factory with the proper indoor coil installed, and cannot be ordered without a coil.
- The air handlers do not have an internal filter rack. An external filter rack or other means of filtration is required.

## 2.5 DIMENSIONS & WEIGHTS

**FIGURE 3**  
**DIMENSIONS AND WEIGHTS**

ELECTRICAL CONNECTIONS MAY EXIT TOP OR EITHER SIDE

HIGH VOLTAGE CONNECTION 7/8",  
1 3/32", 1 31/32" DIA. KNOCK OUTS.

LOW VOLTAGE CONNECTION  
5/8" AND 7/8" KNOCK OUT  
(OUTSIDE OF CABINET)

SUPPLY AIR ↑

**NOTE: 24" CLEARANCE REQUIRED  
IN FRONT OF UNIT FOR FILTER  
AND COIL MAINTENANCE.**

FLANGES ARE PROVIDED  
FOR FIELD INSTALLATION

### Return Air Opening Dimensions

Model Cabinet Size	Return Air Opening Width (Inches)	Return Air Opening Depth/Length (Inches)
17	15 <sup>7</sup> / <sub>8</sub>	19 <sup>3</sup> / <sub>4</sub>
21	19 <sup>3</sup> / <sub>8</sub>	19 <sup>3</sup> / <sub>4</sub>
24	22 <sup>7</sup> / <sub>8</sub>	19 <sup>3</sup> / <sub>4</sub>

AUXILIARY DRAIN CONNECTION  
3/4" FEMALE PIPE THREAD (NPT)  
HORIZONTAL APPLICATION ONLY

PRIMARY DRAIN CONNECTION  
3/4" FEMALE PIPE THREAD (NPT)

AUXILIARY DRAIN CONNECTION  
3/4" FEMALE PIPE THREAD (NPT)  
UPFLOW/DOWNFLOW APPLICATION  
ONLY

LIQUID LINE CONNECTION  
COPPER (SWEAT)

VAPOR LINE CONNECTION  
COPPER (SWEAT)

UPFLOW UNIT SHOWN;  
UNIT MAY BE INSTALLED UPFLOW, DOWNFLOW.  
HORIZONTAL RIGHT, OR LEFT AIR SUPPLY.

A-1038-01

### DIMENSIONAL DATA

MODEL SIZE (-)H1P	REFRIGERANT CONNECTIONS		UNIT HEIGHT IN. [mm]	UNIT WIDTH "W" IN. [mm]	SUPPLY DUCT "A" IN. [mm]	AIRFLOW COIL (NOM.) [L/s]		UNIT WEIGHT / SHIPPING WEIGHT (LBS.) [kg]
	SWEAT (IN.) [MM] ID					LO	HI	UNIT WITH COIL (MAX. kW.)
	LIQUID	VAPOR						
1817ST/2417ST	3/8" [9.53]	3/4" [19.05]	42 <sup>1</sup> / <sub>2</sub> " [1080]	17 <sup>1</sup> / <sub>2</sub> " [444.5]	16" [406.4]	600 [283]	800 [378]	81/95 [37/43]
3017ST/3617ST	3/8" [9.53]	3/4" [19.05]	42 <sup>1</sup> / <sub>2</sub> " [1080]	17 <sup>1</sup> / <sub>2</sub> " [444.5]	16" [406.4]	1000 [472]	1200 [566]	90/104 [41/47]
3621ST	3/8" [9.53]	7/8" [22.23]	42 <sup>1</sup> / <sub>2</sub> " [1080]	21" [533.4]	19 <sup>1</sup> / <sub>2</sub> " [495.3]	1200 [566]	—	109/124 [49/56]
4221ST/4821ST	3/8" [9.53]	7/8" [22.23]	50 <sup>1</sup> / <sub>2</sub> " [1283]	21" [533.4]	19 <sup>1</sup> / <sub>2</sub> " [495.3]	1400 [661]	1600 [755]	130/146 [59/66]
4824ST	3/8" [9.53]	7/8" [22.23]	50 <sup>1</sup> / <sub>2</sub> " [1283]	24 <sup>1</sup> / <sub>2</sub> " [622.3]	23" [584.2]	1600 [755]	—	143/161 [65/73]
6024ST	3/8" [9.53]	7/8" [22.23]	55 <sup>1</sup> / <sub>2</sub> " [1410]	24 <sup>1</sup> / <sub>2</sub> " [622.3]	23" [584.2]	—	1800 [850]	164/181 [75/82]

## 3.0 APPLICATIONS

### 3.1 VERTICAL UPFLOW AND HORIZONTAL LEFT

- Vertical Upflow and Horizontal Left is the factory configuration for all models (see Figure 3).
- If a side return air opening is required, field fabricate a return air plenum with an opening large enough to supply unit and strong enough to support unit weight.
- If return air is to be ducted, install duct flush with floor. Use fireproof resilient gasket 1/8 to 1/4 in. thick between duct, unit and floor. Set unit on floor over opening.

**FIGURE 4**  
DIMENSIONS FOR FRONT CONNECT COIL

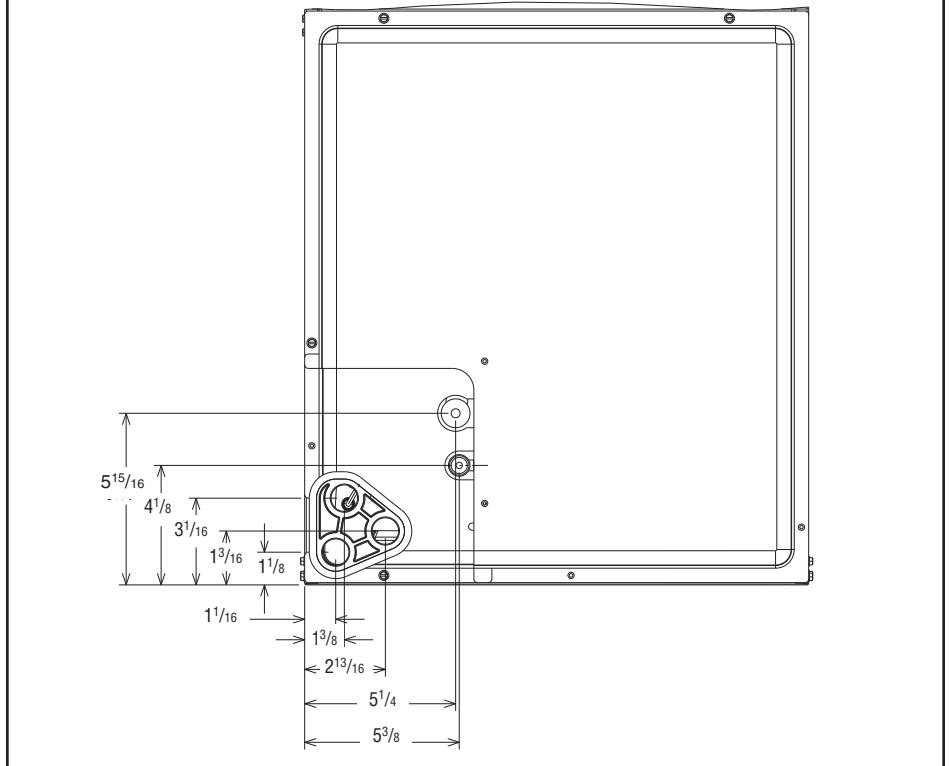

### 3.2 VERTICAL DOWNFLOW AND HORIZONTAL RIGHT

**Conversion to Vertical Downflow and Horizontal Right:** A vertical upflow unit may be converted to vertical downflow. Remove the door and indoor coil and reinstall 180° from original position (see Figure 6). (See kit model number on page 35).

**IMPORTANT:** To comply with certification agencies and the National Electric Code for horizontal right application, the circuit breaker(s) on field-installed electric heater kits must be re-installed per procedure below so that the breaker switch “on” position and marking is up and, “off” position and marking is down.

- To turn breaker(s): Rotate one breaker pair (circuit) at a time starting with the one on the right. Loosen both lugs on the load side of the breaker. Wires are bundles with wire ties, one bundle going to the right lug and one bundle going to the left lug.
- Using a screwdriver or pencil, lift white plastic tab with hole away from breaker until breaker releases from mounting opening (see Figure 5).
- With breaker held in hand, rotate breaker so that “on” position is up, “off” position is down with unit in planned vertical mounting position. Insert right wire bundle into top right breaker lug, ensuring all strands of all wires are inserted fully into lug, and no wire insulation is in lug.
- Tighten lug as tight as possible while holding circuit breaker. Check wires and make sure each wire is secure and none are loose. Repeat for left wire bundle in left top circuit breaker lug.
- Replace breaker by inserting breaker mounting tab opposite white pull tab in opening, hook mounting tab over edge in opening.

**FIGURE 5**  
**ROTATING CIRCUIT BREAKER**

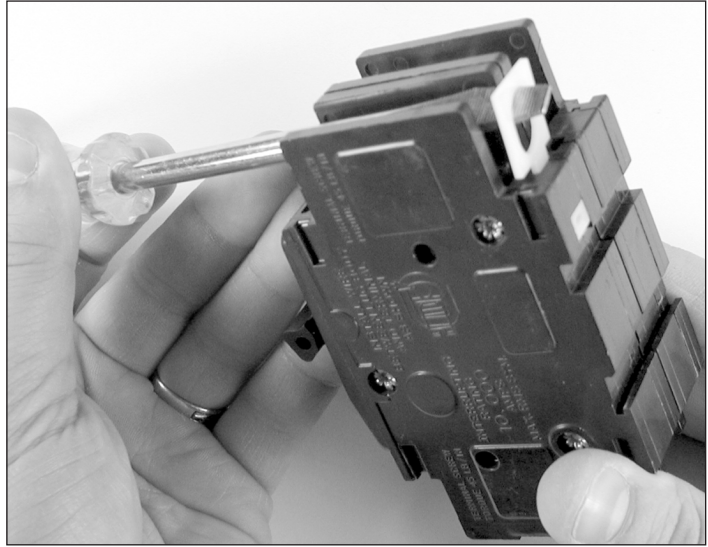

- With screwdriver or pencil, pull white tab with hole away from breaker while setting that side of breaker into opening. When breaker is in place, release tab, locking circuit breaker into opening.
- Repeat above operation for remaining breaker(s) (if more than one is provided).
- Replace single point wiring jumper bar, if it is used, on line side of breaker and tighten securely.
- Double check wires and lugs to make sure all are secure and tight. Check to make sure unit wiring to circuit breaker load lugs match that shown on the unit wiring diagram.
- RXHB combustible floor base is used for all unit sizes. Unit must be centered on combustible base in the width dimension (14<sup>3</sup>/<sub>8</sub>" ). (See Section 14.0 for more information on the combustible floor base.)

**DRIP LOOP:** When installing the unit in down-flow or horizontal-right positions, make sure that the wires coming from the motor form a proper drip loop. This allows water to cascade off the lowest point of the wiring before it enters the motor head. This may require cutting the wire tie and installing a new wire tie to form this loop.

### **⚠ WARNING**

**The RXHB-17, RXHB-21 or RXHB-24 combustible floor base is required when some units with electric heat are applied downflow on combustible flooring. Failure to use the base can cause a fire resulting in property damage, personal injury or death. See CLEARANCES for units requiring a combustible floor base. See the accessory section in this manual for combustible floor base RXHB.**

- Rotate unit into the downflow position, with the coil compartment on top and the blower compartment on bottom.
- The set of coil rails must be moved for vertical down-flow and horizontal right application. Remove the coil rail from the factory configuration (6 screws in all). Fastener clearance holes will need to be drilled in the cabinet sides (proper hole locations are marked with "dimples" for this purpose). Note that the shorter (no notch) coil rail must be mounted on the left-hand side to provide clearance for the drain pan condensate connection boss.
- Reinstall the indoor coil 180° from original position. Ensure the retaining channel is fully engaged with the coil rail. (See Figure 6, Detail A.)
- Secondary drain pan kits RXBM- are required when the unit is configured for the horizontal right position over a finished ceiling and/or living space. (See Section 14.0: Accessories - Kits - Parts.)

**IMPORTANT:** Units cannot be installed horizontally laying on or suspended from the back of the unit.

**FIGURE 6**  
VERTICAL DOWNFLOW & HORIZONTAL RIGHT APPLICATIONS

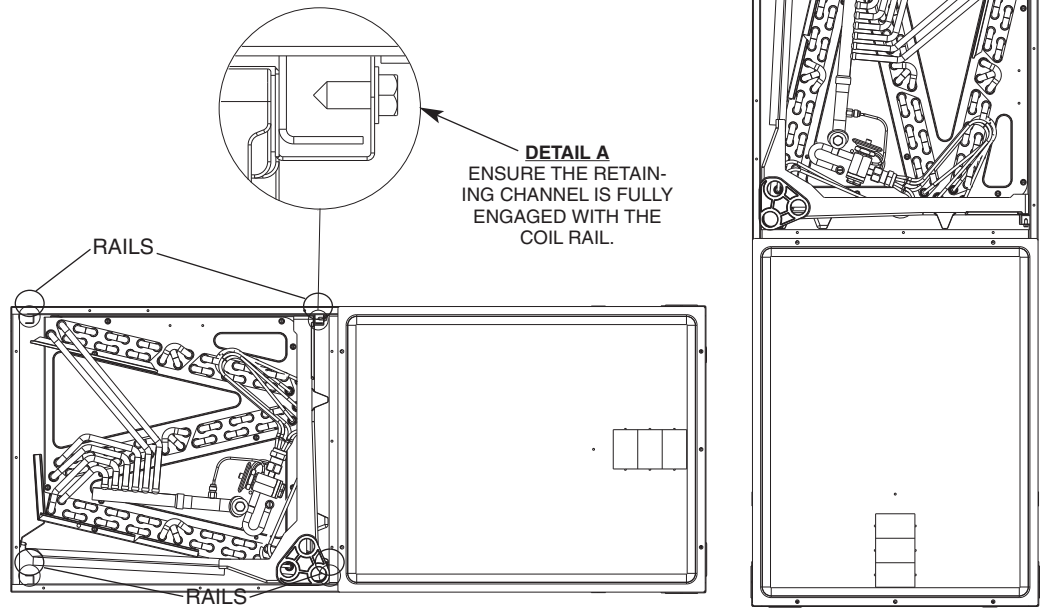

ST-A1213-02

**FIGURE 7**  
INDOOR COIL AND DRAIN PAN SET-UP

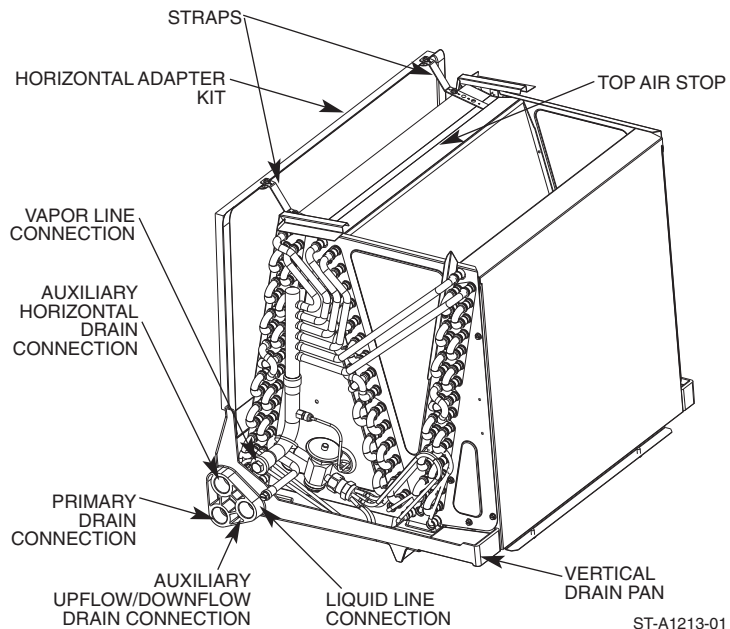

ST-A1213-01

**CAUTION**

Horizontal units must be configured for right hand air supply or left hand air supply. Horizontal drain pan must be located under indoor coil. Failure to use the drain pan can result in property damage.

**3.3 INSTALLATION IN AN UNCONDITIONED SPACE**

The exterior cabinet of an air handler has a greater risk of sweating when installed in an unconditioned space than when it is installed in the conditioned space. This is primarily due to the temperature of the conditioned air moving through the air handler and the air circulating around the unit where it is installed. For this reason, we recommend the following for all air handler applications, but special attention should be paid to those installed in unconditioned spaces:

- Duct sizing and airflow are critical and based on the equipment selected
- Supply and return duct attachment: If other than the factory flanges are used, the attachment of ducting must be insulated and tight to prevent sweating.
- No perimeter supply flanges are provided. If a full perimeter supply duct is used, it is the responsibility of the installer to provide duct flanges as needed, to secure and seal the supply duct to prevent air leakage and the sweating that will result.
- All wire penetrations should be sealed. Take care not to damage, remove or compress insulation in those cases.
- In some cases, the entire air handler can be wrapped with insulation. This can be done as long as the unit is completely enclosed in insulation, sealed and service access is provided to prevent accumulation of moisture inside the insulation.
- As required, use a secondary pan that will protect the structure from excessive sweating or a restricted coil drain line.
- If a heater kit is installed, be sure the breaker or disconnect cover is sealed tightly to the door panel.

### 3.4 INSTALLATION IN MOBILE/MANUFACTURED HOMES

1. Air handler must be secured to the structure using "L" brackets or pipe strap.
2. Allow a minimum of 24 inches (610 mm) front clearance required to access doors.
3. Recommended method for securing air handler:
  - A. If air handler is against the wall, secure top of air handler to wall stud using two 16ga thick angle brackets one on each side. Attach brackets with No. 10 self-tapping  $\frac{1}{2}$ " long screws to air handler and use  $\frac{5}{16}$ " lag screws  $1\frac{1}{2}$ " long to wall stud. Secure bottom of unit with two 16ga "L" brackets with No. 10 self-tapping  $\frac{1}{2}$ " long screws to air handler and use  $\frac{5}{16}$ " lag screws  $1\frac{1}{2}$ " long to floor.
  - B. If air handler is away from wall attach pipe strap to top of air handler using No. 10  $\frac{1}{2}$ " long self-tapping screws on both sides. Angle strap down and away from back of air handler, remove all slack, and fasten to wall stud of structure using  $\frac{5}{16}$ " lag screws  $1\frac{1}{2}$ " long. Secure bottom of unit with two 16ga "L" brackets with No. 10 self-tapping screws to air handler and use  $\frac{5}{16}$ " lag screws  $1\frac{1}{2}$ " long to floor.

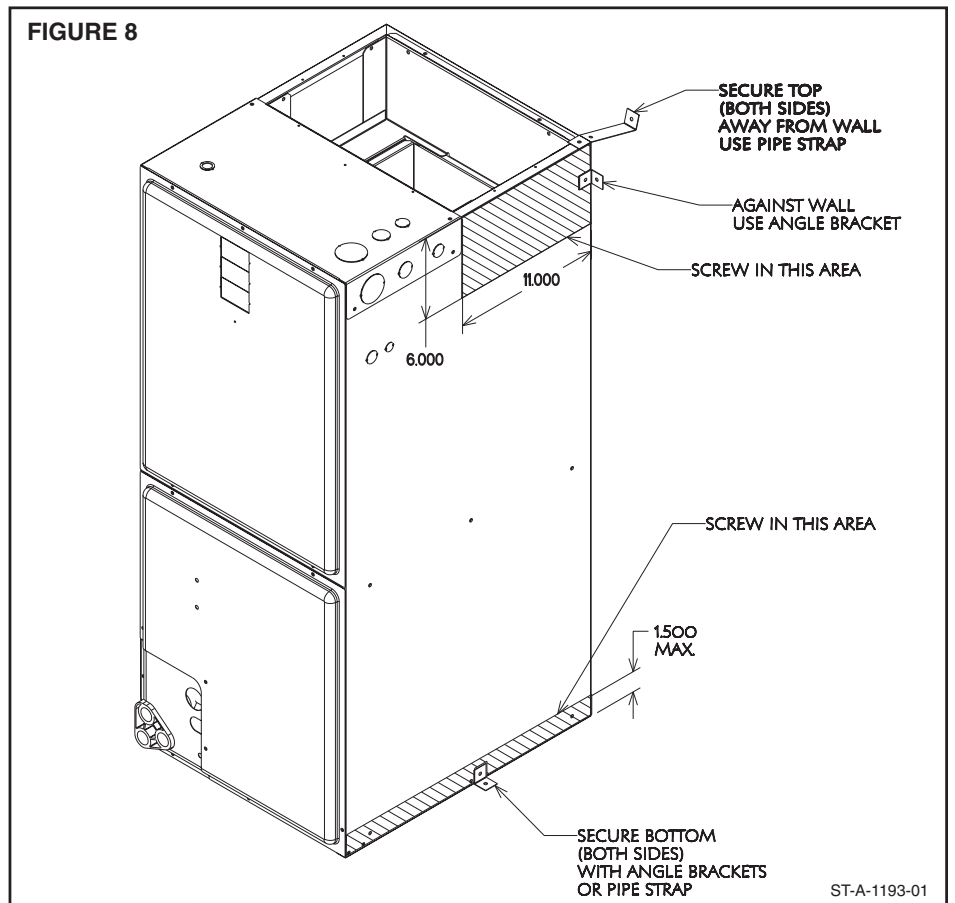

## 4.0 ELECTRICAL WIRING

Field wiring must comply with the National Electric Code (C.E.C. in Canada) and any applicable local ordinance.

### WARNING

**Disconnect all power to unit before installing or servicing. More than one disconnect switch may be required to de-energize the equipment. Hazardous voltage can cause severe personal injury or death.**

### 4.1 POWER WIRING

It is important that proper electrical power is available for connection to the unit model being installed. See the unit nameplate, wiring diagram and electrical data in the installation instructions.

- If required, install a branch circuit disconnect of adequate size, located within sight of, and readily accessible to the unit.
- **IMPORTANT:** After the Electric Heater is installed, units may be equipped with one, two, or three 30/60 amp. circuit breakers. These breaker(s) protect the internal wiring in the event of a short circuit and serve as a disconnect. Circuit breakers installed within the unit do not provide over-current protection of the supply wiring and therefore may be sized larger than the branch circuit protection.
- Supply circuit power wiring must be 75°C minimum copper conductors only. See Electrical Data in this section for ampacity, wire size and circuit protector requirement. Supply circuit protective devices may be either fuses or “HACR” type circuit breakers.
- Power wiring may be connected to either the right, left side or top. Three 7/8”, 1<sup>3/32</sup>”, 1<sup>31/32</sup>” dia. concentric knockouts are provided for connection of power wiring to unit.
- Power wiring is connected to the power terminal block in unit control compartment.

### 4.2 CONTROL WIRING

**IMPORTANT:** Class 2 low voltage control wire should not be run in conduit with power wiring and must be separated from power wiring, unless class 1 wire of proper voltage rating is used.

- Low voltage control wiring should be 18 Awg. color-coded. For lengths longer than 100 ft., 16 Awg. wire should be used.
- Low voltage control connections are made to low voltage pigtails extending from top of air handler (upflow position - see Figure 3). Connections for control wiring are made with wire nuts. Control wiring knockouts (5/8 and 7/8) are also provided on the right and left side of the unit for side connection.
- See wiring diagrams attached to indoor and outdoor sections to be connected, or control wiring diagram booklet supplied with outdoor heat pump section for wiring connection.
- Make sure, after installation, separation of control wiring and power wiring has been maintained.

**FIELD WIRE SIZE FOR 24 VOLT THERMOSTAT CIRCUITS**

Thermostat Load - Amps	SOLID COPPER WIRE - AWG.					
	16	14	12	10	10	10
3.0	16	14	12	10	10	10
2.5	16	14	12	12	10	10
2.0	18	16	14	12	12	10
	50	100	150	200	250	300
	<b>Length of Run - Feet (1)</b>					

(1) Wire length equals twice the run distance.

NOTE: Do not use control wiring smaller than No. 18 AWG between thermostat and outdoor unit.

## 4.2B THERMOSTAT CONNECTIONS

**NOTE:** These low voltage application diagrams are generic. Your indoor/outdoor units may not have all the characteristics shown or may not wire exactly as shown. Refer to the diagrams and information sent with your indoor/outdoor sections.

### WIRE COLOR CODE:

BK - BLACK	G - GREEN	PR - PURPLE	Y - YELLOW
BR - BROWN	GY - GRAY	R - RED	
GL - BLUE	O - ORANGE	W - WHITE	

**FIGURE 9**  
TYPICAL THERMOSTAT: STD COOLING W / ELECTRIC HEAT

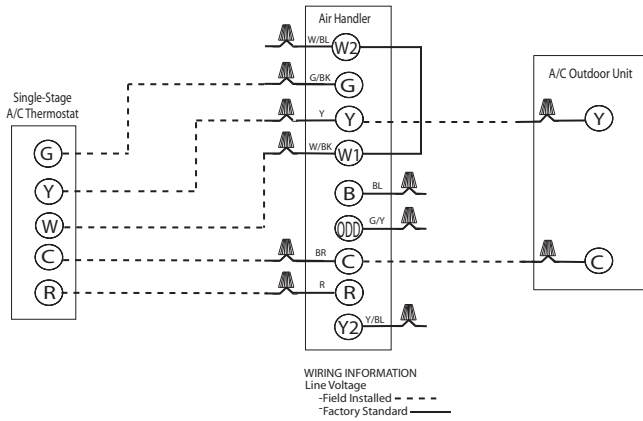

**FIGURE 10**  
TYPICAL THERMOSTAT: STD COOLING W / ELECTRIC HEAT USING A HUMIDISTAT FOR DEHUMIDIFICATION

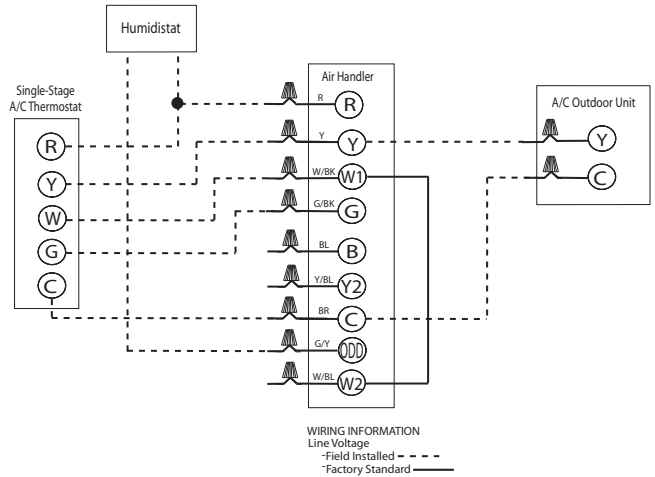

**FIGURE 11**  
TYPICAL THERMOSTAT: STD COOLING W / ELECTRIC HEAT USING A 2-STG DEHUMIDIFYING THERMOSTAT

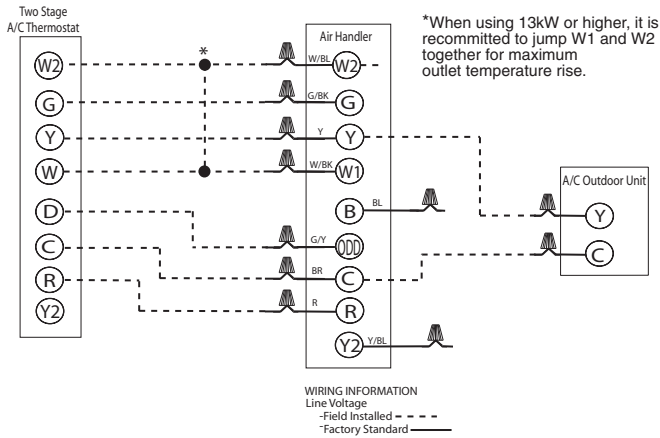

**FIGURE 12**  
TYPICAL THERMOSTAT: HEAT PUMP W / ELECTRIC HEAT

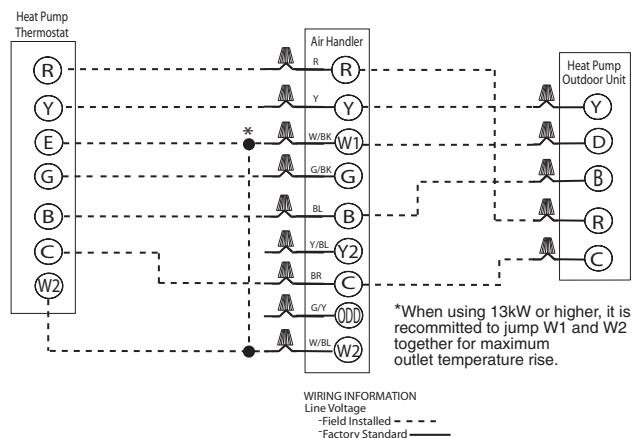

**FIGURE 13**  
TYPICAL THERMOSTAT: HEAT PUMP W / ELECTRIC HEAT USING A HUMIDISTAT FOR DEHUMIDIFICATION

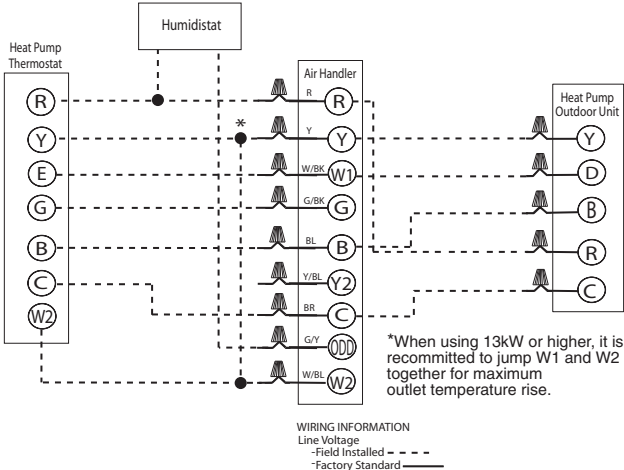

**FIGURE 14**  
TYPICAL THERMOSTAT: HEAT PUMP W / ELECTRIC HEAT USING A 2-STG DEHUMIDIFYING THERMOSTAT

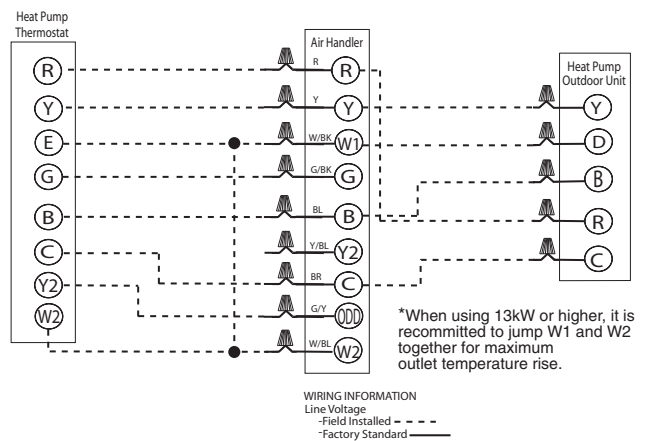

### 4.3 GROUNDING

- Grounding may be accomplished by grounding metal conduit when installed in accordance with electrical codes to the unit cabinet.
- Grounding may also be accomplished by attaching ground wire(s) to ground lug(s) provided in the unit wiring compartment.
- Ground lug(s) are located close to wire entrance on left side of unit (upflow). Lug(s) may be moved to marked locations near wire entrance on right side of unit (upflow), if alternate location is more convenient.
- Use of multiple supply circuits require grounding of each circuit to lug(s) provided in unit.

### 4.4 ELECTRICAL WIRING

#### POWER WIRING

- Field wiring must comply with the National Electrical Code (C.E.C. in Canada) and any applicable local ordinance.
- Supply wiring must be 75°C minimum copper conductors only.
- See electrical data for product Ampacity rating and Circuit Protector requirement.

#### GROUNDING

- This product must be sufficiently grounded in accordance with National Electrical Code (C.E.C. in Canada) and any applicable local ordinance.
- A grounding lug is provided.

### 4.5 ELECTRICAL DATA – BLOWER MOTOR ONLY – NO ELECTRIC HEAT: (-)H1P

MODEL	VOLTAGE	PHASE*	HERTZ	HP	RPM	SPEEDS	CIRCUIT AMPS.	MINIMUM CIRCUIT AMPACITY	MAXIMUM CIRCUIT PROTECTOR
1817ST	115	1	60	1/5	1075	2	2.3	3.0	15
2417ST				1/5	1075	2	3.8	5.0	15
3017ST				1/4	1075	2	4.7	6.0	15
3617ST				1/3	1075	2	6.1	8.0	15
4221ST				1/2	1075	2	7.9	10.0	15
4821ST				3/4	1075	2	8.4	11.0	15
1817ST	208/240	1 & 3	60	1/5	1075	2	1.7	3.0	15
2417ST				1/5	1075	2	1.7	3.0	15
3017ST				1/4	1075	2	2.5	4.0	15
3617ST/3621ST				1/3	1075	2	2.5	4.0	15
4221ST				1/2	1075	2	5.2	7.0	15
4821ST/4824ST				3/4	1075	2	5.2	7.0	15
6024ST	208/240	3	60	3/4	1075	2	5.2	7.0	15
3617ST	480	3	60	1/3	1075	2	1.4	2.0	15
4221ST				1/2	1075	2	2.2	3.0	15
4821ST/4824ST				3/4	1075	2	2.2	3.0	15
6024ST				3/4	1075	2	2.2	3.0	15

\*Blower motors are all single phase motors.

### 4.6 COPPER WIRE SIZE - AWG. (3% VOLTAGE DROP)

SUPPLY LENGTH FEET	SUPPLY CIRCUIT AMPACITY																	
	200 [61]	12	10	8	8	8	6	6	6	4	4	3	3	2	2	1	0	00
150 [46]	12	10	10	10	8	8	6	6	6	4	4	3	3	3	2	1	0	00
100 [30]	14	12	10	10	8	8	8	6	6	4	4	3	3	2	1	0	00	
50 [15]	14	12	10	10	8	8	8	6	6	4	4	3	3	2	1	0	00	
	15	20	25	30	35	40	45	50	60	70	80	90	100	110	125	150	175	

NOTE: WIRE BASED ON COPPER CONDUCTORS 75°C MINIMUM RATING. FOR MORE THAN 3 CONDUCTORS IN A RACEWAY OR CABLE, SEE N.E.C. FOR DERATING THE AMPACITY OF EACH CONDUCTOR.

## 4.7 ELECTRICAL DATA – WITH ELECTRIC HEAT

Installation of the UL Listed original equipment manufacturer provided heater kits listed in the following table is recommended for all auxiliary heating requirements.

### 4.7A ELECTRICAL DATA – WITH ELECTRIC HEAT: (-)H1P

AIR HANDLER MODEL (-)H1P	HEATER MODEL NO.	HEATER KW (208/240V <sup>Ⓢ</sup> ) (480V)	PH/HZ	NO. ELEMENTS - KW PER	TYPE SUPPLY CIRCUIT SINGLE CIRCUIT MULTIPLE CIRCUIT	CIRCUIT AMPS.	MOTOR AMPACITY	MINIMUM CIRCUIT AMPACITY	MAXIMUM CIRCUIT PROTECTION	
1817ST 2417ST	RXBH-17?03J	2.25/3.0	1/60	1-3.0	SINGLE	10.8/12.5	1.7	16/18	20/20	
	RXBH-1724?03J	2.25/3.0	1/60	1-3.0	SINGLE	10.8/12.5	1.7	16/18	20/20	
	RXBH-1724?05J	3.6/4.8	1/60	1-4.8	SINGLE	17.3/20.0	1.7	24/28	25/30	
	RXBH-1724?07J	5.4/7.2	1/60	2-3.6	SINGLE	26.0/30.0	1.7	35/40	35/40	
	RXBH-1724?10J	7.2/9.6	1/60	2-4.8	SINGLE	34.6/40.0	1.7	46/53	50/60	
	<b>RXBH-1724A13J</b>	9.4/12.5	1/60	3-4.17	SINGLE	45.1/52.1	1.7	59/68	60/70	
	<b>RXBH-1724A13J</b>	3.1/4.2	1/60	1-4.17	MULTIPLE CKT 1	15.0/17.4	1.7	21/24	25/25	
		6.3/8.3	1/60	2-4.17	MULTIPLE CKT 2	30.1/34.7	0	38/44	40/45	
		RXBH-1724A07C	5.4/7.2	3/60	3-2.4	SINGLE	15.0/17.3	1.7	21/24	25/25
		RXBH-1724A10C	7.2/9.6	3/60	3-3.2	SINGLE	20.0/23.1	1.7	28/31	30/35
	RXBH-1724A13C	9.4/12.5	3/60	3-4.17	SINGLE	26.1/30.1	1.7	35/40	35/40	
3017ST 3617ST	RXBH-17?03J	2.25/3.0	1/60	1-3.0	SINGLE	10.8/12.5	2.5	17/19	20/20	
	RXBH-1724?03J	2.25/3.0	1/60	1-3.0	SINGLE	10.8/12.5	2.5	17/19	20/20	
	RXBH-1724?05J	3.6/4.8	1/60	1-4.8	SINGLE	17.3/20.0	2.5	25/29	25/30	
	RXBH-1724?07J	5.4/7.2	1/60	2-3.6	SINGLE	26.0/30.0	2.5	36/41	40/45	
	RXBH-1724?10J	7.2/9.6	1/60	2-4.8	SINGLE	34.6/40.0	2.5	47/54	50/60	
	<b>RXBH-1724A13J</b>	9.4/12.5	1/60	3-4.17	SINGLE	45.1/52.1	2.5	60/69	60/70	
	<b>RXBH-1724A13J</b>	3.1/4.2	1/60	1-4.17	MULTIPLE CKT 1	15.0/17.4	2.5	22/25	25/25	
		6.3/8.3	1/60	2-4.17	MULTIPLE CKT 2	30.1/34.7	0	38/44	40/45	
		<b>RXBH-1724A15J</b>	10.8/14.4	1/60	3-4.8	SINGLE	51.9/60.0	2.5	68/79	70/80
	<b>RXBH-1724A15J</b>	3.6/4.8	1/60	1-4.8	MULTIPLE CKT 1	17.3/20.0	2.5	25/29	25/30	
		7.2/9.6	1/60	2-4.8	MULTIPLE CKT 2	34.6/40.0	0	44/50	45/50	
		<b>RXBH-1724A18J</b>	12.8/17.0	1/60	3-5.68	SINGLE	61.6/70.8	2.5	81/92	90/100
	<b>RXBH-1724A18J</b>	4.3/5.7	1/60	1-5.68	MULTIPLE CKT 1	20.5/23.6	2.5	29/33	30/35	
		8.5/11.3	1/60	2-5.68	MULTIPLE CKT 2	41.1/47.2	0	52/59	60/60	
		RXBH-1724A07C	5.4/7.2	3/60	3-2.4	SINGLE	15.0/17.3	2.5	22/25	25/25
		RXBH-1724A10C	7.2/9.6	3/60	3-3.2	SINGLE	20.0/23.1	2.5	29/32	30/35
		RXBH-1724A13C	9.4/12.5	3/60	3-4.17	SINGLE	26.1/30.1	2.5	36/41	40/45
		<b>RXBH-1724A15C</b>	10.8/14.4	3/60	3-4.8	SINGLE	30.0/34.6	2.5	41/47	45/50
		RXBH-1724A18C	12.8/17.0	3/60	3-5.68	SINGLE	35.5/41.0	2.5	48/55	50/60
		RXBH-17A07D	7.2	3/60	2-3.6	SINGLE	8.7	1.4	13	15
	RXBH-17A10D	9.6	3/60	3-3.2	SINGLE	11.6	1.4	17	20	
	RXBH-17A15D	14.4	3/60	3-4.8	SINGLE	17.3	1.4	24	25	
	RXBH-17A18D	17	3/60	3-5.68	SINGLE	20.4	1.4	28	30	
3621ST	RXBH-1724?05J	3.6/4.8	1/60	1-4.8	SINGLE	17.3/20.0	2.5	25/29	25/30	
	RXBH-1724?07J	5.4/7.2	1/60	2-3.6	SINGLE	26.0/30.0	2.5	36/41	40/45	
	RXBH-1724?10J	7.2/9.6	1/60	2-4.8	SINGLE	34.6/40.0	2.5	47/54	50/60	
	<b>RXBH-1724A15J</b>	10.8/14.4	1/60	3-4.8	SINGLE	51.9/60.0	2.5	68/79	70/80	
	<b>RXBH-1724A15J</b>	3.6/4.8	1/60	1-4.8	MULTIPLE CKT 1	17.3/20.0	2.5	25/29	25/30	
		7.2/9.6	1/60	2-4.8	MULTIPLE CKT 2	34.6/40.0	0	44/50	45/50	
	<b>RXBH-1724A18J</b>	12.8/17.0	1/60	4-4.26	SINGLE	61.6/70.8	2.5	81/92	90/100	
	RXBJ-1724A18J	6.4/8.5	1/60	2-4.26	MULTIPLE CKT 1	30.8/35.4	2.5	42/48	45/50	
		6.4/8.5	1/60	2-4.26	MULTIPLE CKT 2	30.8/35.4	0	39/45	40/45	
		RXBH-1724A07C	5.4/7.2	3/60	3-2.4	SINGLE	15.0/17.3	2.5	22/25	25/25
		RXBH-1724A10C	7.2/9.6	3/60	3-3.2	SINGLE	20.0/23.1	2.5	29/32	30/35
		<b>RXBH-1724A15C</b>	10.8/14.4	3/60	3-4.8	SINGLE	30.0/34.6	2.5	41/47	45/50
		RXBH-1724A18C	12.8/17.0	3/60	3-5.68	SINGLE	35.5/41.0	2.5	48/55	50/60
		RXBH-24A07D	7.2	3/60	2-3.6	SINGLE	8.7	1.4	13	15
		RXBH-24A10D	9.6	3/60	3-3.2	SINGLE	11.6	1.4	17	20
		RXBH-24A15D	14.4	3/60	3-4.8	SINGLE	17.3	1.4	24	25
		RXBH-24A18D	17	3/60	3-5.68	SINGLE	20.4	1.4	28	30

? Heater Kit Connection Type A=Breaker B=Terminal Block c=Pullout Disconnect

**4.7A ELECTRICAL DATA – WITH ELECTRIC HEAT: (-)H1P - continued**

AIR HANDLER MODEL (-)H1P	HEATER MODEL NO.	HEATER KW (208/240V <sup>①</sup> ) (480V)	PH/HZ	NO. ELEMENTS - KW PER	TYPE SUPPLY CIRCUIT SINGLE CIRCUIT MULTIPLE CIRCUIT	CIRCUIT AMPS.	MOTOR AMPACITY	MINIMUM CIRCUIT AMPACITY	MAXIMUM CIRCUIT PROTECTION
4221ST 4821ST 4824ST	RXBH-1724?05J	3.6/4.8	1/60	1-4.8	SINGLE	17.3/20.0	5.2	29/32	30/35
	RXBH-1724?07J	5.4/7.2	1/60	2-3.6	SINGLE	26.0/30.0	5.2	39/44	40/45
	RXBH-1724?10J	7.2/9.6	1/60	2-4.8	SINGLE	34.6/40.0	5.2	50/57	50/60
	RXBH-1724A15J	10.8/14.4	1/60	3-4.8	SINGLE	51.9/60.0	5.2	72/82	80/90
	RXBH-1724A15J	3.6/4.8	1/60	1-4.8	MULTIPLE CKT 1	17.3/20.0	5.2	29/32	30/35
		7.2/9.6	1/60	2-4.8	MULTIPLE CKT 2	34.6/40.0	0.0	44/50	45/50
	RXBH-1724A18J	12.8/17	1/60	4-4.26	SINGLE	61.6/70.8	5.2	84/95	90/100
	RXBH-1724A18J	6.4/8.5	1/60	2-4.26	MULTIPLE CKT 1	30.8/35.4	5.2	45/51	45/60
		6.4/8.5	1/60	2-4.26	MULTIPLE CKT 2	30.8/35.4	0.0	39/45	40/45
	RXBH-24A20J	14.4/19.2	1/60	4-4.8	SINGLE	69.2/80	5.2	93/107	100/110
	RXBH-24A20J	7.2/9.6	1/60	2-4.8	MULTIPLE CKT 1	34.6/40.0	5.2	50/57	50/60
		7.2/9.6	1/60	2-4.8	MULTIPLE CKT 2	34.6/40.0	0.0	44/50	45/50
	RXBH-24A25J	18.0/24.0	1/60	6-4.0	SINGLE	86.4/99.9	5.2	115/132	125/150
	RXBH-24A25J (4-ton only)	6.0/8.0	1/60	2-4.0	MULTIPLE CKT 1	28.8/33.3	5.2	43/49	45/50
		6.0/8.0	1/6	2-4.0	MULTIPLE CKT 2	28.8/33.3	0.0	36/42	40/45
		6.0/8.0	1/60	2-4.0	MULTIPLE CKT 3	28.8/33.3	0.0	36/42	40/45
	RXBH-1724A07C	5.4/7.2	3/60	3-2.4	SINGLE	15.0/17.3	5.2	26/29	30/30
	RXBH-1724A10C	7.2/9.6	3/60	3-3.2	SINGLE	20.0/23.1	5.2	32/36	35/40
	RXBH-1724A15C	10.8/14.4	3/60	3-4.8	SINGLE	30.0/34.6	5.2	44/50	45/50
	RXBH-1724A18C	12.8/17.0	3/60	3-2.84	SINGLE	35.6/41.0	5.2	51/58	60/60
	RXBH-24A20C*	14.4/19.2	3/60	3-3.2	SINGLE	40.0/46.2	5.2	57/65	60/70
	RXBH-24A20C	7.2/9.6	3/60	3-3.2	MULTIPLE CKT 1	20.0/23.1	5.2	32/36	35/40
		7.2/9.6	3/60	3-3.2	MULTIPLE CKT 2	20.0/23.1	0.0	25/29	25/30
	RXBH-24A25C*	18.0/24.0	3/60	6-4.0	SINGLE	50.0/57.8	5.2	69/79	70/80
	RXBH-24A25C (4-ton only)	9.0/12.0	3/60	3-4.0	MULTIPLE CKT 1	25.0/28.9	5.2	38/43	40/45
		9.0/12.0	3/60	3-4.0	MULTIPLE CKT 2	25.0/28.9	0.0	32/37	35/40
	RXBH-24A07D	7.2	3/60	2-3.6	SINGLE	8.7	2.2	14	15
	RXBH-24A10D	9.6	3/60	3-3.2	SINGLE	11.6	2.2	18	20
	RXBH-24A15D	14.4	3/60	3-4.8	SINGLE	17.3	2.2	25	25
	RXBH-24A18D	17	3/60	3-5.68	SINGLE	20.4	2.2	29	30
RXBH-24A20D	19.2	3/60	6-3.2	SINGLE	23.2	2.2	32	35	
RXBH-24A25D (4-ton only)	24.0	3/60	6-4.0	SINGLE	28.8	2.2	39	40	
6024ST	RXBH-1724?07J	5.4/7.2	1/60	2-3.6	SINGLE	26.0/30.0	5.2	39/44	40/45
	RXBH-1724?10J	7.2/9.6	1/60	2-4.8	SINGLE	34.6/40.0	5.2	50/57	50/60
	RXBH-1724A15J	10.8/14.4	1/60	3-4.8	SINGLE	51.9/60.0	5.2	72/82	80/90
	RXBH-1724A15J	3.6/4.8	1/60	1-4.8	MULTIPLE CKT1	17.3/20.0	5.2	29/32	30/35
		7.2/9.6	1/60	2-4.8	MULTIPLE CKT 2	34.6/40.0	0	44/50	45/50
	RXBH-1724A18J	12.8/17.0	1/60	4-4.26	SINGLE	61.6/70.8	5.2	84/95	90/100
	RXBH-1724A18J	6.4/8.5	1/60	2-4.26	MULTIPLE CKT 1	30.8/35.4	5.2	45/51	45/60
		6.4/8.5	1/60	2-4.26	MULTIPLE CKT 2	30.8/35.4	0	39/45	40/45
	RXBH-24A20J	14.4/19.2	1/60	4-4.8	SINGLE	69.2/80	5.2	93/107	100/110
	RXBH-24A20J	7.2/9.6	1/60	2-4.8	MULTIPLE CKT 1	34.6/40.0	5.2	50/57	50/60
		7.2/9.6	1/60	2-4.8	MULTIPLE CKT 2	34.6/40.0	0	44/50	45/50
	RXBH-24A25J	18.0/24.0	1/60	6-4.0	SINGLE	86.4/99.9	5.2	115/132	125/150
	RXBH-24A25J	6.0/8.0	1/60	2-4.0	MULTIPLE CKT 1	28.8/33.3	5.2	43/49	45/50
		6.0/8.0	1/60	2-4.0	MULTIPLE CKT 2	28.8/33.3	0	36/42	40/45
		6.0/8.0	1/60	2-4.0	MULTIPLE CKT 3	28.8/33.3	0	36/42	40/45
	RXBH-24A30J	21.6/28.8	1/60	6-4.8	SINGLE	103.8/120	5.2	137/157	150/175
	RXBH-24A30J	7.2/9.6	1/60	2-4.8	MULTIPLE CKT 1	34.6/40.0	5.2	50/57	50/60
		7.2/9.6	1/60	2-4.8	MULTIPLE CKT 2	34.6/40.0	0	44/50	45/50
		7.2/9.6	1/60	2-4.8	MULTIPLE CKT 3	34.6/40.0	0	44/50	45/50

? Heater Kit Connection Type A = Breaker B = Terminal Block C = Pullout Disconnect

#### 4.7A ELECTRICAL DATA – WITH ELECTRIC HEAT: (-)H1P - continued

AIR HANDLER MODEL (-)H1P	HEATER MODEL NO.	HEATER KW (208/240V <sup>ⓐ</sup> ) (480V)	PH/HZ	NO. ELEMENTS - KW PER	TYPE SUPPLY CIRCUIT SINGLE CIRCUIT MULTIPLE CIRCUIT	CIRCUIT AMPS.	MOTOR AMPACITY	MINIMUM CIRCUIT AMPACITY	MAXIMUM CIRCUIT PROTECTION
6024ST	RXBH-1724A07C	5.4/7.2	3/60	3-2.4	SINGLE	15.0/17.3	5.2	26/29	30/30
	RXBH-1724A10C	7.2/9.6	3/60	3-3.2	SINGLE	20.0/23.1	5.2	32/36	35/40
	RXBH-1724A15C	10.8/14.4	3/60	3-4.8	SINGLE	30.0/34.6	5.2	44/50	45/50
	RXBH-1724A18C	12.8/17.0	3/60	3-2.84	SINGLE	35.6/41.0	5.2	51/58	60/60
	RXBH-24A20C*	14.4/19.2	3/60	3-3.2	SINGLE	40.0/46.2	5.2	57/65	60/70
	RXBH-24A20C	7.2/9.6	3/60	3-3.2	MULTIPLE CKT 1	20.0/23.1	5.2	32/36	35/40
		7.2/9.6	3/60	3-3.2	MULTIPLE CKT 2	20.0/23.1	0	25/29	25/30
	RXBH-24A25C*	18.0/24.0	3/60	6-4.0	SINGLE	50.0/57.8	5.2	69/79	70/80
	RXBH-24A25C	9.0/12.0	3/60	3-4.0	MULTIPLE CKT 1	25.0/28.9	5.2	38/43	40/45
		9.0/12.0	3/60	3-4.0	MULTIPLE CKT 2	25.0/28.9	0	32/37	35/40
	RXBH-24A30C*	21.6/28.8	3/60	6-4.8	SINGLE	60.0/69.4	5.2	82/94	90/100
	RXBH-24A30C	10.8/14.4	3/60	3-4.8	MULTIPLE CKT 1	30.0/34.7	5.2	44/50	45/50
		10.8/14.4	3/60	3-4.8	MULTIPLE CKT 2	30.0/34.7	0	38/44	40/45
	RXBH-24A07D	7.2	3/60	2-3.6	SINGLE	8.7	2.2	14	15
	RXBH-24A10D	9.6	3/60	3-3.2	SINGLE	11.6	2.2	18	20
	RXBH-24A15D	14.4	3/60	3-4.8	SINGLE	17.3	2.2	25	25
	RXBH-24A18D	17	3/60	3-5.68	SINGLE	20.4	2.2	29	30
	RXBH-24A20D	19.2	3/60	6-3.2	SINGLE	23.2	2.2	32	35
RXBH-24A25D	24.0	3/60	6-4.0	SINGLE	28.8	2.2	39	40	
RXBH-24A30D*	28.8	3/60	6-4.8	SINGLE	34.6	2.2	46	50	

- ? Heater Kit Connection Type A=Breaker B=Terminal Block C=Pullout Disconnect

ⓐ D Voltage = 480 Volts.

\*Values only. No single point kit available.

**NOTES:**

- Electric heater BTUH - (heater watts + motor watts) x 3.414 (see airflow table for motor watts.)
- Supply circuit protective devices may be fuses or "HACR" type circuit breakers.
- If non-standard fuse size is specified, use next size larger standard fuse size.
- Largest motor load is included in single circuit or circuit 1 of multiple circuits.
- Heater loads are balanced on 3 phase models with 3 or 6 heaters only.
- No electrical heating elements are permitted to be used with A Voltage (115V) air handler.
- J Voltage (208/240V) single phase air handler is designed to be used with single or three phase 208/240V electric heaters. In the case of connecting 3 phase power to air handler terminal block without the heater, bring only two leads to terminal block, cap, insulate and fully secure the third lead.
- Do not use 480V electrical heaters on 208/240V air handler.
- If the kit is listed under both single and multiple circuits, the kit is shipped from factory as multiple circuits. For single phase application, Jumper bar kit RXBJ-A21 and RXBJ-A31 can be used to convert multiple circuits to a single supply circuit. Refer to Accessory Section for details.

## 4.7B HEATER KIT SUPPLEMENTAL INFORMATION

MFD: MO/YEAR 01/2006 AIR CONDITIONING DIVISION MADE IN THE U.S.A. / FRQ: MO/JANNE FAIT DANS L'USA

MODEL/MODELE # SERIAL/EN SERIE # M0106 38751

VOLTS 208/240 PH/HZ 1/60 MOTOR HP./F.L.A. 1/2 4.1 / MOTEUR PSC/F.L.A.

**ATTENTION:** MARK HEATER INSTALLED / L'APPAREIL DE CHAUFFAGE DE MARQUE A INSTALLER

HEATER MODEL/MODELE D'APPAREIL DE CHAUFFAGE	TYPE SUPPLY CIRCUIT/TYPES LE CIRCUIT DE PROVISION	VOLTAGE/TENSION	PHASE	KW	HEATER AMPS/AMPLIS D'APPAREIL DE CHAUFFAGE	MOTOR AMPS/LES AMPLIS MOTEURS	PROTECTION LA PROTECTION MAXIMUM DE OVERCURRENT	MINIMUM BRANCH CIRCUIT AMPCITY/AMPCAPACITY MINIMUM DE CIRCUIT DE BRANCHE
NO HEAT				0.0		4.1	15	5.2
RYBH-24A05J	SINGLE	208/240	1/60	3.6/4.8	17.3/20.0	6.0	30/35	30/33
RYBH-24A07J	SINGLE	208/240	1/60	5.4/7.2	26.0/30.0	6.0	40/45	40/45
RYBH-24A10J	SINGLE	208/240	1/60	7.2/9.6	34.6/40.0	6.0	60/60	51/58
RYBH-24A15J	SINGLE	208/240	1/60	10.8/14.4	51.9/60.0	6.0	80/90	73/83
RYBH-24A15J	MULTI CKT 1	208/240	1/60	3.6/4.8	17.3/20.0	6.0	30/35	30/33
RYBH-24A15J	MULTI CKT 2	208/240	1/60	7.2/9.6	34.6/40.0	0.0	45/50	44/50
RYBH-24A18J	SINGLE	208/240	1/60	12.8/17.0	61.2/70.8	6.0	90/100	84/96
RYBH-24A18J	MULTI CKT 1	208/240	1/60	6.4/8.5	30.8/35.4	6.0	50/60	46/52
RYBH-24A18J	MULTI CKT 2	208/240	1/60	6.4/8.5	30.8/35.4	0.0	40/45	39/45
RYBH-24A20J	SINGLE	208/240	1/60	14.4/19.2	69.2/80.0	6.0	100/110	94/108
RYBH-24A20J	MULTI CKT 1	208/240	1/60	7.2/9.6	34.6/40.0	6.0	60/60	51/58
RYBH-24A20J	MULTI CKT 2	208/240	1/60	7.2/9.6	34.6/40.0	0.0	45/50	44/50
RYBH-24A07C	SINGLE	208/240	3/60	5.4/7.2	15.0/17.3	6.0	30/30	27/30
RYBH-24A10C	SINGLE	208/240	3/60	7.2/9.6	20.0/23.1	6.0	35/40	33/37
RYBH-24A15C	SINGLE	208/240	3/60	10.8/14.4	30.0/34.6	6.0	45/60	45/51
RYBH-24A18C	SINGLE	208/240	3/60	12.4/17.0	35.6/41.0	6.0	60/60	52/59
RYBH-24A18C	MULTI CKT 1	208/240	3/60	6.4/8.5	17.8/20.5	6.0	30/35	30/34
RYBH-24A18C	MULTI CKT 2	208/240	3/60	6.4/8.5	17.8/20.5	0.0	25/30	23/26
RYBH-24A20C	SINGLE	208/240	3/60	14.2/19.2	40.0/46.2	6.0	60/70	58/66
RYBH-24A20C	MULTI CKT 1	208/240	3/60	7.2/9.6	20.0/23.1	6.0	35/40	33/37
RYBH-24A20C	MULTI CKT 2	208/240	3/60	7.2/9.6	20.0/23.1	0.0	25/30	25/29

S = SINGLE CIRCUIT/CIRCUIT SIMPLE M = MULTIPLE CIRCUIT/CIRCUIT MULTIPLE

INDOOR BLOWER MOTOR LOAD INCLUDED IN CIRCUIT # 1 OR TOTAL SUPPLY WIRE MUST BE RATED AT 75°C MINIMUM COPPER CONDUCTORS ONLY. TEST EXTERNAL STATIC RANGE .1 TO .5 IN. W.C. (HEAT PUMP & ELECTRIC HEAT).

UNITS WITH ELECTRIC HEATERS: CLEARANCE TO COMBUSTIBLE MATERIAL TO BE 0 IN. TO UNIT CASING AND 0 IN. TO PLENUM AND DUCT FOR FIRST 36 IN. MODELS HAVE INTEGRAL CIRCUIT BREAKERS WHICH PROVIDE SUPPLEMENTARY OVERCURRENT PROTECTION AND SERVE AS A MAINTENANCE "DISCONNECT". SUPPLY CIRCUIT NOT TO EXCEED 120 VOLTS TO GROUND ON SINGLE PHASE UNITS. REPLACE LINE SIDE BREAKER COVER(S) AFTER MAKING WIRING CONNECTIONS TO BREAKER(S). IF BLOWER-CONTROL ASSEMBLY REQUIRES REMOVAL, SEE "WARNING HAZARDOUS VOLTAGE".

CHARGEMENT DU MOTEUR SOUFFLEUR INTERNE INCLUS DANS LE CIRCUIT # 1 OU CAPACITÉ DU CÂBLAGE D'ALIMENTATION TOTAL DOIT ÊTRE DE 75C DU MINIMUM DE CONDUCTEURS DE CUIVRE SEULEMENT. TESTER L'INTERVALLE STATIQUE EXTERNE : 1 À 5 PO W.C (THERMOPOMPE ET CHAUFFAGE ÉLECTRIQUE)

UNITÉS AVEC CHAUFFAGES ÉLECTRIQUES : LE DÉGAGEMENT AUX MATIÈRES COMBUSTIBLES DOIT ÊTRE DE 0 po AU BOITIER DE L'UNITÉ ET DE 0 po AU PLÉNUM ET CONDUIT POUR LES 36 PREMIERS po. LES MODÈLES DISPOSENT DE DISJONCTEURS INTÉGRÉS QUI FOURNISSENT UNE PROTECTION SUPPLÉMENTAIRE DE SURINTENSITÉ DE COURANT ET SERVENT DE « SECTIONNEUR » D'ENTRETIEN. LE CIRCUIT D'ALIMENTATION NE DOIT PAS DÉPASSER 120 VOLTS JUSQU'AU SOL SUR DES UNITÉS MONOPHASÉES. REMPLACER LE(S) COUVERCLE(S) DU DISJONCTEUR DU CÔTÉ SECTEUR APRÈS AVOIR EFFECTUÉ LA CONNEXION DES CÂBLAGES AU(X) DISJONCTEUR(S). SI L'ASSEMBLAGE DE CONTRÔLE DU VENTILATEUR A BESOIN D'ÊTRE DÉASSEMBLÉ, CONSULTER "AVERTISSEMENT DE TENSION DANGEREUSE"

If a heater kit is listed both Single and Multi-circuit, the kit is shipped as a Multi-circuit and will require a single point kit

Only listed kits can be applied

Contractor should "mark or check" the left column for the kit installed

These are the required maximum and minimum circuit breaker sizes for overcurrent protection and should not be confused with the size of the breakers installed in the heater kit.

Heater Kit Supplemental Information: What allows the manufacturer to use standard Circuit Breakers up to 60 amps inside the air handler, when using an approved Heater Kit?

National Electric Code (Section 424-22b) and our UL requirements allow us to subdivide heating element circuits, of less than 48 amps, using breakers of not more than 60 amps and, additionally by, NEC 424-3b, a rating not less than 125 percent of the load and NEC 424-22c, which describes the supplementary overcurrent protection required to be factory-installed within, or on the heater. The breakers in the heater kit are not, and have never been, by NEC, intended to protect power wiring leading to the air handler unit. The breakers in the heating kit are for short circuit protection. All internal unit wiring, where the breakers apply, has been UL approved for short circuit protection.

Ampacity, (not breaker size), determines supply circuit wire size. The ampacity listed on the unit rating plate and the Maximum and Minimum circuit breaker size (noted above) or in the units specification sheet or installation instructions provides the information to properly select wire and circuit breaker/protector size. The National Electric Code (NEC) specifies that the supply or branch circuit must be protected at the source.

## 5.0 AIRFLOW PERFORMANCE

Airflow performance data is based on cooling performance with a coil and no filter in place. Select performance table for appropriate unit size, voltage and number of electric heaters to be used. Make sure external static applied to unit allows operation within the minimum and maximum limits shown in table below for both cooling and electric heat operation. For optimum blower performance, operate the unit in the .3 to .7 in W.C. external static range. Units with coils should be applied with a minimum of .1 in W.C. external static.

### 5.1 AIRFLOW OPERATING LIMITS

Cabinet Width	17		17/21		21		24	
Cooling BTUH x 1,000	18	24	30	36	42	48	48	60
Cooling Tons Nominal	1.5	2	2.5	3	3.5	4	4	5
Heat Pump or Air Conditioning Maximum Heat/Cool CFM [L/s] (37.5 CFM [18 L/s]/1,000 BTUH) (450 CFM [212 L/s]/Ton Nominal)	675 [319]	900 [425]	1125 [531]	1350 [637]	1575 [743]	1800 [850]	1800 [850]	1930 [911]
Heat Pump or Air Conditioning Nominal Heat/Cool CFM [L/s] (33.3 CFM [16 L/s]/1,000 BTUH) (400 CFM [189 L/s]/Ton Nominal)	600 [283]	800 [378]	1000 [472]	1200 [566]	1400 [661]	1600 [755]	1600 [755]	1800 [850]
Heat Pump or Air Conditioning Minimum Heat/Cool CFM [L/s] (30.0 CFM [14 L/s]/1,200 BTUH) (360 CFM [170 L/s]/Ton Nominal)	540 [255]	720 [340]	900 [425]	1080 [510]	1260 [595]	1440 [680]	1440 [680]	1620 [765]
Maximum kW Electric Heating & Minimum Electric Heat CFM [L/s]	13 487 [230]	13 617 [291]	18 814 [384]	18 1054 [497]	20 1171 [553]	25 1502 [709]	25 1502 [709]	30 1666 [786]
Maximum Electric Heat Rise °F [°C]	80 [26.7]	63 [17.2]	66 [18.9]	51 [10.6]	49 [9.4]	50 [10]	50 [10]	54 [12.2]

## 5.2 240V AIRFLOW PERFORMANCE DATA – (-)H1P (PSC MOTOR)

Model Number (-)H1P	Motor Speed From Factory	Manufacturer Recommended Air Flow Range (Min / Max) CFM	Blower Size/ Motor HP [W] # of Speeds	Motor Speed	PSC CFM[L/s] Air Delivery/RPM/Watts (No Filter)							
					External Static Pressure-Inches W.C.							
						0.1 [.02]	0.2 [.05]	0.3 [.07]	0.4 [.10]	0.5 [.12]	0.6 [.15]	0.7 [.17]
1817ST No heater	High 240 V	523/705 CFM [247/333 L/s]	10x6 1/5HP[149] 2 Speed	Low	CFM	681 [321]	636 [300]	606 [286]	567 [268]	523 [247]	—	—
					RPM	541	601	670	714	768	—	—
					Watts	193	181	173	164	157	—	—
				High	CFM	—	—	—	—	705 [333]	650 [307]	599 [283]
					RPM	—	—	—	—	815	861	989
					Watts	—	—	—	—	239	227	204
1817ST with 13kw heater	High 240 V	493/655 CFM [233/309 L/s]	10x6 1/5HP[149] 2 Speed	Low	CFM	651 [307]	606 [286]	576 [272]	537 [253]	493 [233]	—	—
					RPM	571	631	700	744	798	—	—
					Watts	184	172	164	155	148	—	—
				High	CFM	—	—	—	—	655 [309]	600 [283]	549 [259]
					RPM	—	—	—	—	840	886	1014
					Watts	—	—	—	—	228	216	193
2417ST No heater	High 240 V	682/897 CFM [322/423 L/s]	10x6 1/5HP[149] 2 Speed	Low	CFM	875 [413]	806 [380]	787 [371]	739 [349]	682 [322]	—	—
					RPM	648	700	745	794	827	—	—
					Watts	259	255	243	234	227	—	—
				High	CFM	—	—	—	—	897 [423]	851 [402]	765 [361]
					RPM	—	—	—	—	906	925	955
					Watts	—	—	—	—	332	318	306
2417ST with 13kw heater	High 240 V	652/847 CFM [308/400 L/s]	10x6 1/5HP[149] 2 Speed	Low	CFM	845 [399]	776 [366]	757 [357]	709 [335]	652 [308]	—	—
					RPM	678	730	775	824	857	—	—
					Watts	250	246	234	225	218	—	—
				High	CFM	—	—	—	—	847 [400]	801 [378]	715 [337]
					RPM	—	—	—	—	931	950	980
					Watts	—	—	—	—	321	307	295
3017ST No heater	High 240 V	883/1015 CFM [417/479 L/s]	10x8 1/4HP[186] 2 Speed	Low	CFM	1038 [490]	1010 [477]	976 [461]	925 [437]	883 [417]	—	—
					RPM	721	771	799	848	880	—	—
					Watts	325	314	303	290	286	—	—
				High	CFM	—	—	—	—	1015 [479]	963 [454]	890 [420]
					RPM	—	—	—	—	928	955	974
					Watts	—	—	—	—	356	341	329
3017ST with 18kw heater	High 240 V	833/915 CFM [393/432 L/s]	10x8 1/4HP[186] 2 Speed	Low	CFM	988 [466]	960 [453]	926 [437]	875 [413]	833 [393]	—	—
					RPM	771	821	849	898	930	—	—
					Watts	305	294	283	270	266	—	—
				High	CFM	—	—	—	—	915 [432]	863 [407]	790 [373]
					RPM	—	—	—	—	953	980	999
					Watts	—	—	—	—	326	311	299
3617ST/-3621ST No heater	High 240 V	1104/1194 CFM [521/563 L/s]	10x8 1/3HP[249] 2 Speed	Low	CFM	1229 [580]	1201 [567]	1170 [552]	1141 [538]	1104 [521]	—	—
					RPM	788	833	872	909	951	—	—
					Watts	466	462	427	406	395	—	—
				High	CFM	—	—	—	—	1248 [589]	1194 [563]	1133 [535]
					RPM	—	—	—	—	1008	1028	1042
					Watts	—	—	—	—	488	475	454
3617ST/3621ST with 18kw heater	High 240 V	1054/1094 CFM [497/516 L/s]	10x8 1/3HP[249] 2 Speed	Low	CFM	1179 [556]	1151 [543]	1120 [529]	1091 [515]	1054 [497]	—	—
					RPM	838	883	922	959	1001	—	—
					Watts	446	442	407	386	375	—	—
				High	CFM	—	—	—	—	1148 [542]	1094 [516]	1033 [487]
					RPM	—	—	—	—	1033	1053	1067
					Watts	—	—	—	—	458	445	424
4221ST No heater	High 240 V	1211/1514 CFM [571/714 L/s]	10x10 1/2HP[373] 2 Speed	Low	CFM	1526 [720]	1474 [696]	1427 [673]	1307 [617]	1241 [586]	—	—
					RPM	834	870	902	948	968	—	—
					Watts	560	549	535	476	462	—	—
				High	CFM	—	—	—	—	1537 [725]	1418 [669]	1334 [630]
					RPM	—	—	—	—	1072	1077	1085
					Watts	—	—	—	—	860	835	820
4221ST with 20kw heater	High 240 V	1225/1500 CFM [538/667 L/s]	10x10 1/2HP[373] 2 Speed	Low	CFM	1456 [687]	1404 [663]	1357 [640]	1237 [584]	1171 [553]	—	—
					RPM	886	906	925	959	992	—	—
					Watts	542	524	505	468	431	—	—
				High	CFM	—	—	—	—	1437 [678]	1318 [622]	1234 [582]
					RPM	—	—	—	—	1080	1090	1105
					Watts	—	—	—	—	840	800	785

## 5.2 240V AIRFLOW PERFORMANCE DATA – (-)H1P (PSC MOTOR) - continued

Model Number (-)H1P	Motor Speed From Factory	Manufacturer Recommended Air Flow Range (Min / Max) CFM	Blower Size/ Motor HP [W] # of Speeds	Motor Speed	PSC CFM[L/s] Air Delivery/RPM/Watts (No Filter)							
					External Static Pressure-Inches W.C.							
					0.1 [.02]	0.2 [.05]	0.3 [.07]	0.4 [.10]	0.5 [.12]	0.6 [.15]	0.7 [.17]	
4821ST/4824ST No heater	High 240 V	1455/1787 CFM [687/843 L/s]	10x10 3/4HP[559] 2 Speed	Low	CFM	1560 [736]	1550 [731]	1543 [728]	1510 [713]	1455 [687]	—	—
					RPM	807	840	914	941	989	—	—
					Watts	601	589	553	541	507	—	—
				High	CFM	—	—	—	—	1787 [843]	1679 [792]	1575 [743]
					RPM	—	—	—	—	1089	1098	1110
					Watts	—	—	—	—	695	665	630
4821ST/4824ST with 25kw heater	High 240 V	1225/1500 CFM [654/796 L/s]	10x10 3/4HP[559] 2 Speed	Low	CFM	1490 [703]	1480 [698]	1473 [695]	1440 [680]	1385 [654]	—	—
					RPM	857	897	937	974	1011	—	—
					Watts	581	569	533	521	487	—	—
				High	CFM	—	—	—	—	1687 [796]	1579 [745]	1475 [696]
					RPM	—	—	—	—	1095	1107	1120
					Watts	—	—	—	—	670	635	615
6024ST No heater	High 240 V	1766/1965 CFM [833/927 L/s]	11x11 3/4HP[559] 2 Speed	Low	CFM	1944 [917]	1912 [902]	1860 [878]	1813 [856]	1766 [833]	—	—
					RPM	764	803	838	865	889	—	—
					Watts	779	763	747	729	708	—	—
				High	CFM	—	—	—	—	1965 [927]	1908 [900]	1854 [875]
					RPM	—	—	—	—	943	967	977
					Watts	—	—	—	—	828	799	795
6024ST with 30kw heater	High 240 V	1666/1844 CFM [786/870 L/s]	11x11 3/4HP[559] 2 Speed	Low	CFM	1844 [870]	1812 [855]	1760 [831]	1713 [808]	1666 [786]	—	—
					RPM	839	865	890	913	935	—	—
					Watts	745	729	713	696	678	—	—
				High	CFM	—	—	—	—	1865 [880]	1808 [853]	1754 [828]
					RPM	—	—	—	—	987	1001	1014
					Watts	—	—	—	—	788	766	744

### NOTE:

- All 208/240V PSC motors have voltage taps for 208 and 240 volts.
- All 208/240V PSC motors are shipped on high speed and 240 volts.
- If the application external static is less than 0.5" WC, adjust the motor speed to the low static speed as described below.
  - Unplug the black motor wire off the relay on the control board and plug in the red motor wire.
  - Replace the cap on the black motor wire.
- Voltage change (208/240V motors):
  - Move the orange lead to transformer 208V tap from 240V tap. Replace the wire cap on 240V tap.
  - Unplug the purple motor wire off the transformer and plug in the yellow motor wire.
  - Replace the cap on the purple motor wire.
- The above airflow table lists the airflow information for air handlers without heater and air handler with maximum heater allowed for each model.
- The following formula can be used to calculate the approximate airflow, if a smaller (N kw) than the maximum heater kit is installed.  
 Approximate Airflow = Airflow without heater - (Airflow without heater - Airflow with maximum heater) X (N kw/maximum heater kw)

### 5.3 115/208/480V AIRFLOW PERFORMANCE DATA – (-)H1P (PSC MOTOR)

Model Number (-)H1P	Motor Speed From Factory	Manufacturer Recommended Air Flow Range (Min / Max) CFM	Blower Size/ Motor HP [W] # of Speeds	Motor Speed	PSC CFM[L/s] Air Delivery/RPM/Watts (No Filter)							
					External Static Pressure-Inches W.C.							
						0.1 [.02]	0.2 [.05]	0.3 [.07]	0.4 [.10]	0.5 [.12]	0.6 [.15]	0.7 [.17]
1817ST No heater	High	517/711 CFM [244/336 L/s]	10x6 1/5HP[149] 2 Speed	Low	CFM	668 [315]	637 [301]	595 [281]	560 [264]	517 [244]	—	—
					RPM	541	596	657	706	761	—	—
					Watts	180	171	166	161	155	—	—
				High	CFM	—	—	—	—	711 [336]	662 [312]	614 [290]
					RPM	—	—	—	—	812	853	890
					Watts	—	—	—	—	243	227	210
1817ST with 13kw heater	High	487/661 CFM [230/312 L/s]	10x6 1/5HP[149] 2 Speed	Low	CFM	638 [301]	607 [286]	565 [267]	530 [250]	487 [230]	—	—
					RPM	571	656	687	736	791	—	—
					Watts	171	162	157	152	146	—	—
				High	CFM	—	—	—	—	661 [312]	612 [289]	564 [266]
					RPM	—	—	—	—	837	878	915
					Watts	—	—	—	—	232	216	199
2417ST No heater	High	647/888 CFM [305/419 L/s]	10x6 1/5HP[149] 2 Speed	Low	CFM	817 [386]	779 [368]	757 [357]	693 [327]	647 [305]	—	—
					RPM	616	667	715	770	808	—	—
					Watts	239	230	221	206	196	—	—
				High	CFM	—	—	—	—	888 [419]	828 [391]	774 [365]
					RPM	—	—	—	—	875	908	958
					Watts	—	—	—	—	331	313	301
2417ST with 13kw heater	High	617/838 CFM [291/395 L/s]	10x6 1/5HP[149] 2 Speed	Low	CFM	787 [371]	749 [353]	727 [343]	663 [313]	617 [291]	—	—
					RPM	646	697	745	800	838	—	—
					Watts	230	221	212	197	187	—	—
				High	CFM	—	—	—	—	838 [395]	778 [367]	724 [342]
					RPM	—	—	—	—	900	933	983
					Watts	—	—	—	—	320	302	290
3017ST No heater	High	864/1004 CFM [408/474 L/s]	10x8 1/4HP[186] 2 Speed	Low	CFM	1022 [482]	987 [466]	940 [444]	903 [426]	864 [408]	—	—
					RPM	700	754	794	833	870	—	—
					Watts	344	313	302	294	288	—	—
				High	CFM	—	—	—	—	1004 [474]	951 [449]	883 [417]
					RPM	—	—	—	—	924	953	975
					Watts	—	—	—	—	364	352	344
3017ST with 18kw heater	High	814/904 CFM [384/427 L/s]	10x8 1/4HP[186] 2 Speed	Low	CFM	972 [459]	937 [442]	890 [420]	853 [403]	814 [384]	—	—
					RPM	750	804	844	883	920	—	—
					Watts	324	293	282	274	268	—	—
				High	CFM	—	—	—	—	904 [427]	851 [402]	783 [370]
					RPM	—	—	—	—	949	978	1000
					Watts	—	—	—	—	334	322	314
3617ST/3621ST No heater	High	1110/1248 CFM [524/589 L/s]	10x8 1/3HP[249] 2 Speed	Low	CFM	1201 [567]	1170 [552]	1141 [538]	1104 [521]	1062 [501]	—	—
					RPM	833	872	909	951	965	—	—
					Watts	462	427	406	396	385	—	—
				High	CFM	—	—	—	—	1194 [563]	1134 [535]	1078 [509]
					RPM	—	—	—	—	1024	1042	1060
					Watts	—	—	—	—	475	454	417
3617ST/3621ST with 18kw heater	High	1060/1148 CFM [500/542 L/s]	10x8 1/3HP[249] 2 Speed	Low	CFM	1151 [543]	1120 [529]	1091 [515]	1054 [497]	1012 [478]	—	—
					RPM	883	922	959	1001	1015	—	—
					Watts	442	407	386	376	365	—	—
				High	CFM	—	—	—	—	1094 [516]	1034 [488]	978 [462]
					RPM	—	—	—	—	1049	1067	1085
					Watts	—	—	—	—	445	424	386
4221ST No heater	High	1241/1537 CFM [586/725 L/s]	10x10 1/2HP[373] 2 Speed	Low	CFM	1493 [705]	1449 [684]	1363 [643]	1287 [607]	1211 [571]	—	—
					RPM	822	858	885	931	958	—	—
					Watts	540	519	506	484	459	—	—
				High	CFM	—	—	—	—	1514 [714]	1411 [666]	1315 [621]
					RPM	—	—	—	—	1061	1069	1078
					Watts	—	—	—	—	710	702	677
4221ST with 20kw heater	High	1225/1500 CFM [553/678 L/s]	10x10 1/2HP[373] 2 Speed	Low	CFM	1423 [672]	1379 [651]	1293 [610]	1217 [574]	1141 [538]	—	—
					RPM	870	882	925	957	992	—	—
					Watts	514	508	490	461	431	—	—
				High	CFM	—	—	—	—	1414 [667]	1311 [619]	1215 [573]
					RPM	—	—	—	—	1067	1080	1094
					Watts	—	—	—	—	700	678	665

### 5.3 115/208/480V AIRFLOW PERFORMANCE DATA – (-)H1P (PSC MOTOR) - continued

Model Number (-)H1P	Motor Speed From Factory	Manufacturer Recommended Air Flow Range (Min / Max) CFM	Blower Size/ Motor H.P. [W] # of Speeds	Motor Speed	PSC CFM[L/s] Air Delivery/RPM/Watts (No Filter)							
					External Static Pressure-Inches W.C.							
						0.1 [.02]	0.2 [.05]	0.3 [.07]	0.4 [.10]	0.5 [.12]	0.6 [.15]	0.7 [.17]
4821ST/4824ST No heater	High	1395/1824 CFM [658/861 L/s]	10x10 3/4HP[559] 2 Speed	Low	CFM	1488 [702]	1419 [670]	1466 [692]	1430 [675]	1395 [658]	—	—
					RPM	812	861	912	943	973	—	—
					Watts	554	545	526	508	491	—	—
				High	CFM	—	—	—	—	1824 [861]	1767 [834]	1653 [780]
					RPM	—	—	—	—	1102	1112	1121
					Watts	—	—	—	—	871	830	770
4821ST/4824ST with 25kw heater	High	1225/1500 CFM [625/814 L/s]	10x10 3/4HP[559] 2 Speed	Low	CFM	1418 [669]	1349 [637]	1396 [659]	1360 [642]	1325 [625]	—	—
					RPM	862	899	935	965	995	—	—
					Watts	534	525	506	588	471	—	—
				High	CFM	—	—	—	—	1724 [814]	1667 [787]	1553 [733]
					RPM	—	—	—	—	1116	1119	1130
					Watts	—	—	—	—	810	780	730
6024ST No heater	High	1710/1967 CFM [807/928 L/s]	11x11 3/4HP[559] 2 Speed	Low	CFM	1866 [881]	1833 [865]	1806 [852]	1772 [836]	1710 [807]	—	—
					RPM	764	803	824	856	886	—	—
					Watts	514	756	733	715	701	—	—
				High	CFM	—	—	—	—	1967 [928]	1916 [904]	1863 [879]
					RPM	—	—	—	—	948	959	991
					Watts	—	—	—	—	850	827	816
6024ST with 30kw heater	High	1640/1796 CFM [773/847 L/s]	11x11 3/4HP[559] 2 Speed	Low	CFM	1796 [848]	1763 [832]	1736 [819]	1702 [803]	1640 [774]	—	—
					RPM	828	860	878	890	1001	—	—
					Watts	735	718	705	695	678	—	—
				High	CFM	—	—	—	—	1867 [881]	1816 [857]	1763 [832]
					RPM	—	—	—	—	989	1005	1020
					Watts	—	—	—	—	818	795	780

**NOTE:**

- All 208/240V PSC motors have voltage taps for 208 and 240 volts.
- All 208/240V PSC motors are shipped on high speed and 240 volts.
- All 115V PSC motors are shipped on high speed.
- If the application external static is less than 0.5" WC, adjust the motor speed to the low static speed as described below:
  - Unplug the black motor wire off the relay on the control board and plug in the red motor wire.
  - Replace the cap on the black motor wire.
- Voltage change (208/240V motors):
  - Move the orange lead to transformer to 208V tap from 240V tap. Replace the wire cap on 240V tap.
  - Unplug the purple motor wire off the transformer and plug in the yellow motor wire.
  - Replace the cap on the purple motor wire.
- All 480V PSC motors are shipped on high speed.
- If the application external static is less than 0.5" WC, adjust the motor speed to the low static speed as described below for 3-ton through 4-ton air handlers.
  - Unplug the black motor wire off the relay and remove the cap from the red motor wire.
  - Plug the red motor wire to the relay and connect the black motor wire with the yellow motor wire.
- For 5-ton air handler, unplug the black motor wire off the relay and plug in the red motor wire, then cap the black motor wire. There is no yellow motor wire on 5-ton air handler.

**WARNING:** Do not connect red motor wire with yellow motor wire in any circumstance on 480V PSC motors. Connecting red motor wire with yellow motor wire will result in permanent motor damage.

- The above airflow table lists the airflow information for air handlers without heater and air handler with maximum heater allowed for each model.
- The following formula can be used to calculate the approximate airflow, if a smaller (N kw) than the maximum heater kit is installed.  

$$\text{Approximate Airflow} = \text{Airflow without heater} - (\text{Airflow without heater} - \text{Airflow with maximum heater}) \times (\text{N kw}/\text{maximum heater kw})$$

## 6.0 DUCTWORK

Field ductwork must comply with the National Fire Protection Association NFPA 90A, NFPA 90B and any applicable local ordinance.

### WARNING

**Do not, under any circumstances, connect return ductwork to any other heat producing device such as fireplace insert, stove, etc. Unauthorized use of such devices may result in fire, carbon monoxide poisoning, explosion, personal injury or property damage.**

Sheet metal ductwork run in unconditioned spaces must be insulated and covered with a vapor barrier. Fibrous ductwork may be used if constructed and installed in accordance with SMACNA Construction Standard on Fibrous Glass Ducts. Ductwork must comply with National Fire Protection Association as tested by U/L Standard 181 for Class I Air Ducts. Check local codes for requirements on ductwork and insulation.

- Duct system must be designed within the range of external static pressure the unit is designed to operate against. It is important that the system airflow be adequate. Make sure supply and return ductwork, grills, special filters, accessories, etc. are accounted for in total resistance. See airflow performance tables in this manual.
- Design the duct system in accordance with “ACCA” Manual “D” Design for Residential Winter and Summer Air Conditioning and Equipment Selection. Latest editions are available from: “ACCA” Air Conditioning Contractors of America, 1513 16th Street, N.W., Washington, D.C. 20036. If duct system incorporates **flexible air duct**, be sure **pressure drop** information (straight length plus all turns) shown in “ACCA” Manual “D” is accounted for in system.
- Supply plenum is attached to the 3/4” duct flanges supplied with the unit. Attach flanges around the blower outlet.

**IMPORTANT:** If an elbow is included in the plenum close to the unit, it must not be smaller than the dimensions of the supply duct flange on the unit.

- **IMPORTANT:** The front flange on the return duct if connected to the blower casing must not be screwed into the area where the power wiring is located. Drills or sharp screw points can damage insulation on wires located inside unit.
- Secure the supply and return ductwork to the unit flanges, using proper fasteners for the type of duct used and tape the duct-to-unit joint as required to prevent air leaks.

## 7.0 REFRIGERANT CONNECTIONS

Keep the coil connections sealed until refrigerant connections are to be made. See the Installation Instructions for the outdoor unit for details on line sizing, tubing installation, and charging information.

Coil is shipped with a low (5 - 10 PSIG) pressure charge of dry nitrogen. Evacuate the system before charging with refrigerant.

Install refrigerant tubing so that it does not block service access to the front of the unit.

Nitrogen should flow through the refrigerant lines while brazing.

Make sure to protect TXV, copper to aluminum joint, and service valves from overheating by use of wet rag or some type of shielding. Double tip torches are not recommended.

Use a brazing shield to protect the cabinet’s paint from being damaged by torch flames.

After the refrigerant connections are made, seal the gap around the connections with pressure sensitive gasket. If necessary, cut the gasket into two pieces for a better seal. (See Figure 4.)

### 7.1 TEV SENSING BULB

**IMPORTANT:** DO NOT perform any soldering with the TEV bulb attached to any line. After soldering operations have been completed, clamp the TEV bulb securely on the suction line at the 10 to 2 o’clock position with the strap provided in the parts bag. Insulate the TEV sensing bulb and suction line with the provided pressure sensitive insulation (size 4” x 7”) and secure with provided wire ties.

**IMPORTANT: TEV sensing bulb should be located on a horizontal section of suction line, just outside of coil box. The copper sensing bulb must never be placed on any aluminum tube as this will result in galvanic corrosion and eventual failure of the aluminum tube.**

### 7.2 ORIFICE SIZE

The air handler comes standard with a flow check piston installed. The piston may need to be changed to a different orifice size depending upon the outdoor unit. The table on next page lists the recommended orifice size for various outdoor units.

Indoor	Factory Piston	Nominal Tons	Refrigerant	Piston
2417	.057	1½ Ton	R-410A	*.049
		2 Ton		.057
3617	.071	2½	R-410A	*.062
		3 Ton		.071
4821 4824	.077	3½ Ton	R-410A	*.074
		4 Ton		.077
2417	.057	1½ Ton	R-22	**0.053
		2 Ton	10 Seer	**0.063
3617	.071	2½ Ton	R-22	**0.065
		3 Ton	10 Seer	**0.070
4821 4824	.077	3½ Ton	R-22	**0.074
		4 Ton	10 Seer	**0.077

\*Piston will be supplied with outdoor unit in parts bag.

\*\*Pistons not supplied and are an estimate. Size may vary for different outdoor units.

**FIGURE 15**  
BULB LOCATION

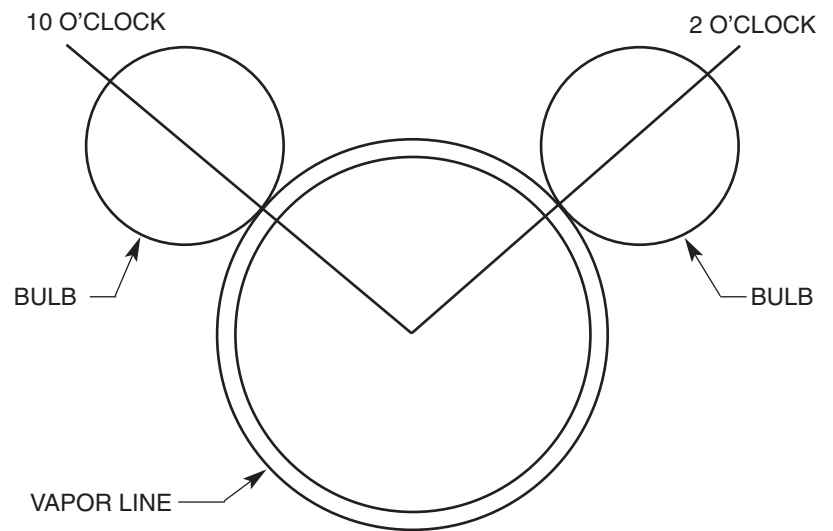

**FIGURE 16**  
BULB LOCATION

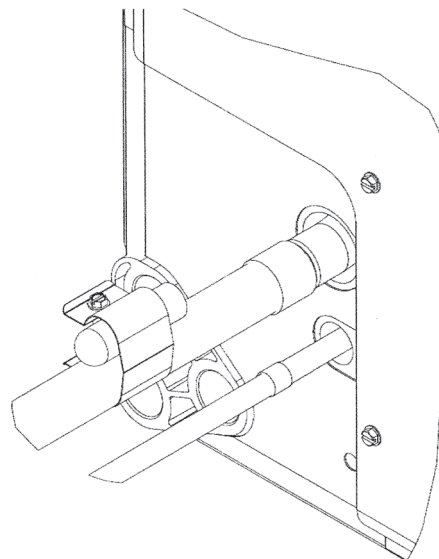

## 7.3 CONDENSATE DRAIN TUBING

Consult local codes or ordinances for specific requirements.

**IMPORTANT:** When making drain fitting connections to the drain pan, use a thin layer of Teflon paste, silicone or Teflon tape and install hand tight.

**IMPORTANT:** When making drain fitting connections to drain pan, do not overtighten. Overtightening fittings can split pipe connections on the drain pan.

- Install drain lines so they do not block service access to front of the unit. Minimum clearance of 24 inches is required for filter, coil or blower removal and service access.
- Make sure unit is level or pitched slightly toward primary drain connection so that water will drain completely from the pan. (See Figure 7.)
- Do not reduce drain line size less than connection size provided on condensate drain pan.

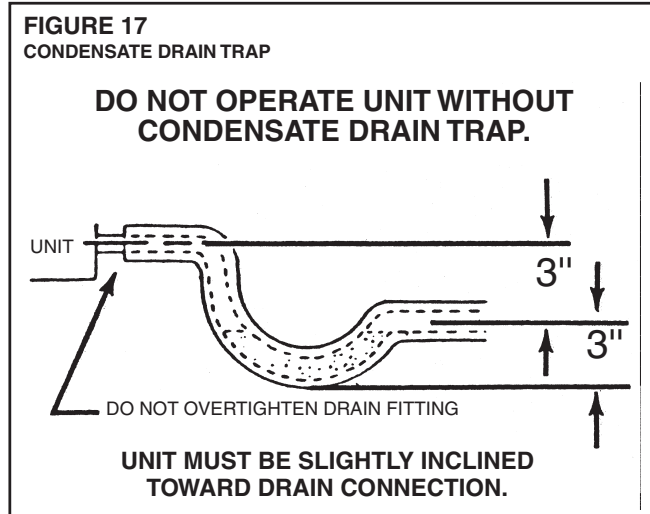

- All drain lines must be pitched downward away from the unit a minimum of 1/8" per foot of line to ensure proper drainage.
- Do not connect condensate drain line to a closed or open sewer pipe. Run condensate to an open drain or outdoors.
- The drain line should be insulated where necessary to prevent sweating and damage due to condensate forming on the outside surface of the line.
- Make provisions for disconnecting and cleaning of the primary drain line should it become necessary. Install a 3 in. trap in the primary drain line as close to the unit as possible. Make sure that the top of the trap is below connection to the drain pan to allow complete drainage of pan (See Figure 7).
- Auxiliary drain line should be run to a place where it will be noticeable if it becomes operational. Occupant should be warned that a problem exists if water should begin running from the auxiliary drain line.
- Plug the unused drain connection with the plugs provided in the parts bag, using a thin layer of teflon paste, silicone or teflon tape to form a water tight seal.
- Test condensate drain pan and drain line after installation is complete. Pour water into drain pan, enough to fill drain trap and line. Check to make sure drain pan is draining completely, no leaks are found in drain line fittings, and water is draining from the termination of the primary drain line.

## 7.4 DUCT FLANGES

Field-installed duct flanges (4 pieces) are shipped with units. Install duct flanges as needed on top of the unit. (See Figure 3.)

## 8.0 AIR FILTER (not factory-installed)

- External filter or other means of filtration is required. Units should be sized for a maximum of 300 feet/min. air velocity or that recommended for the type filter installed.

Filter application and placement are critical to airflow, which may affect the heating and cooling system performance. Reduced airflow can shorten the life of the system's major components, such as motor, limits, elements, heat relays, evaporator coil or compressor. Consequently, we recommend that the return air duct system have only one filter location. For systems with a return air filter grill or multiple filter grills, can have a filter installed at each of the return air openings.

If high efficiency filters or electronic air cleaners are used in the system, it is important that the airflow is not reduced to maximize system performance and life. Always verify that the system's airflow is not impaired by the filtering system that has been installed, by performing a temperature rise and temperature drop test.

**IMPORTANT:** DO NOT DOUBLE FILTER THE RETURN AIR DUCT SYSTEM. DO NOT FILTER THE SUPPLY AIR DUCT SYSTEM.

## **WARNING**

**Do not operate the system without filters. A portion of the dust entrained in the air may temporarily lodge in the duct runs and at the supply registers. Any circulated dust particles could be heated and charred by contact with the air handler elements. This residue could soil ceilings, walls, drapes, carpets and other articles in the house.**

**Soot damage may occur with filters in place, when certain types of candles, oil lamps or standing pilots are burned.**

## **9.0 SEQUENCE OF OPERATION**

### **9.1 COOLING (COOLING ONLY OR HEAT PUMP)**

- When the thermostat “calls for cooling,” the circuit between R and G is completed, causing the blower relay (BR) to energize. The N.O. contacts will close, causing the indoor blower motor (IBM) to operate. The circuit between R and Y is also completed: This circuit closes the contactor (CC) in the outdoor unit starting the compressor (COMP) and outdoor fan motor (OFM).

### **9.2 HEATING (ELECTRIC HEAT ONLY)**

- When the thermostat “calls for heat,” the circuit between R and W is completed, and the heater sequencer (HR<sub>1</sub>) is energized. The heating elements (HE) and the indoor blower motor (IBM) will come on. Units with a second heater sequencer (HR<sub>2</sub>) can be connected with the first sequencer (HR<sub>1</sub>) to W on the thermostat sub-base or connected to a second stage W<sub>2</sub> on the sub-base.

### **9.3 HEATING (HEAT PUMP)**

- When the thermostat “calls for heat,” the circuits between R and B, R and Y and R and G are completed. Circuit R and B energizes the reversing valve (RV) switching it to the heating position (remains energized as long as selector switch is in “heat” position). Circuit R and Y energizes the contactor (CC) starting the outdoor fan motor (OFM) and compressor (COMP). Circuit R and G energizes the blower relay (BR) starting the indoor blower motor (IBM).
- If the room temperature should continue to fall, circuit R and W<sub>2</sub> is completed by the second-stage heat room thermostat. Circuit R-W<sub>2</sub> energizes a heat sequencer (HR<sub>1</sub>). The completed circuit will energize supplemental electric heat. Units with a second heater sequencer (HR<sub>2</sub>) can be connected with first sequencer (HR<sub>1</sub>) to W<sub>2</sub> on thermostat or connected to a third heating stage W<sub>2</sub> on the thermostat sub-base. A light on the thermostat indicates when supplemental heat is being energized.

### **9.4 BLOWER TIME DELAY (HEATING OR COOLING)**

- All models are equipped with a blower time delay (BTD) in lieu of a blower relay (BR) (see wiring diagram). The blower will run for 30 seconds after the blower time delay (BTD) is de-energized.

### **9.5 DEFROST (DEFROST HEAT CONTROL)**

- For sequence of operation for defrost controls, see outdoor heat pump installation instructions.
- Supplemental heat during defrost can be provided by connecting the purple (PU) pigtail in the outdoor unit to the W on the thermostat. This will complete the circuit between R and W through a set of contacts in the defrost relay (DR) when the outdoor heat pump is in defrost. This circuit, if connected, will help prevent cold air from being discharged from the indoor unit during defrost.
- For most economical operation, if cold air is not of concern during defrost, the purple wire can be left disconnected. Supplemental heat will then come on only when called for by second stage room thermostat.

## 9.6 EMERGENCY HEAT (HEATING HEAT PUMP)

- If selector switch on thermostat is set to the emergency heat position, the heat pump will be locked out of the heating circuit, and all heating will be electric heat. Jumper should be placed between W<sub>2</sub> and E on the thermostat sub-base so that the electric heat control will transfer to the first stage heat on the thermostat. This will allow the indoor blower to cycle on and off with the electric heat when the fan switch is in the auto position.

## 9.7 ROOM THERMOSTAT (ANTICIPATOR SETTING)

See instructions with outdoor section, condensing unit or heat pump for recommended room thermostats.

- On units with one electric heat sequencer (HR<sub>1</sub>) (see wiring diagram on unit), heat anticipator setting should be .16.
- On units with two electric heat sequencers (HR<sub>1</sub> & HR<sub>2</sub>) (see wiring diagram on unit), heat anticipator setting should be .32 if both are connected to same stage on thermostat. Setting should be .16 if (HR<sub>1</sub> & HR<sub>2</sub>) are connected to separate stages.

**NOTE:** Some thermostats contain a fixed, non-adjustable heat anticipator. Adjustment is not permitted.

- The thermostat should be mounted 4 to 5 feet above the floor on an inside wall of the living room or a hallway that has good air circulation from the other rooms being controlled by the thermostat. It is essential that there be free air circulation at the location of the same average temperature as other rooms being controlled. Movement of air should not be obstructed by furniture, doors, draperies, etc. The thermostat should not be mounted where it will be affected by drafts, hot or cold water pipes or air ducts in walls, radiant heat from fireplace, lamps, the sun, T.V. or an outside wall. See instruction sheet packaged with thermostat for mounting and installation instructions.

---

# 10.0 CALCULATIONS

## 10.1 CALCULATING TEMPERATURE RISE

- The formula for calculating air temperature rise for electric resistance heat is:

$$\text{Temperature Rise } ^\circ\text{F} = \frac{3.16 \times \text{Watts}}{\text{CFM}}$$

Where: 3.16 = Constant, CFM = Airflow

## 10.2 CALCULATING BTUH HEATING CAPACITY

- The formula for calculating BTUH heating capacity for electric resistance heat is:

$$\text{BTUH Heating} = \text{Watts} \times 3.412$$

Where: 1 kW = 1000 Watts, 3.412 = Btuh/Watt

## 10.3 CALCULATING AIRFLOW CFM

- The formula for calculating airflow using temperature rise and heating BTUH for units with electric resistance heat is:

$$\text{CFM} = \frac{\text{Heating BTUH}}{1.08 \times \text{Temp. Rise}}$$

## 10.4 CALCULATING CORRECTION FACTOR

- For correction of electric heat output (kW or BTUH) or temperature rise at voltages other than rated voltage multiply by the following correction factor:

$$\text{Correction Factor} = \frac{\text{Applied Voltage}^2}{\text{Rated Voltage}^2}$$

## 11.0 PRE-START CHECKLIST

PRE-START CHECKLIST	
<input type="radio"/> YES <input type="radio"/> NO	Is unit properly located, level, secure and service-able?
<input type="radio"/> YES <input type="radio"/> NO	Has auxiliary pan been provided under the unit with separate drain? (Units installed above a finished ceiling).
<input type="radio"/> YES <input type="radio"/> NO	Is condensate line properly sized, run, trapped, pitched and tested?
<input type="radio"/> YES <input type="radio"/> NO	Is ductwork correctly sized, run, taped and insulated?
<input type="radio"/> YES <input type="radio"/> NO	Have all cabinet openings and wiring been sealed with caulking?
<input type="radio"/> YES <input type="radio"/> NO	Is the filter clean, in place and of adequate size?
<input type="radio"/> YES <input type="radio"/> NO	Is the wiring tight, correct and to the wiring diagram?
<input type="radio"/> YES <input type="radio"/> NO	Is the unit properly grounded and protected (fused)?
<input type="radio"/> YES <input type="radio"/> NO	Is the thermostat heat anticipator been set properly?
<input type="radio"/> YES <input type="radio"/> NO	Is the unit circuit breaker(s) rotated properly "on" up - "off" down?
<input type="radio"/> YES <input type="radio"/> NO	Are the unit circuit breaker(s) line lug cover(s) in place?
<input type="radio"/> YES <input type="radio"/> NO	Are all access panels in place and secure?

Refer to outdoor unit installation instructions for system start-up instructions and refrigerant charging instructions.

## 12.0 MAINTENANCE

For continuing high performance, and to minimize possible equipment failure, it is essential that periodic maintenance be performed on this equipment. Consult your local dealer as to the proper frequency of maintenance and the availability of a maintenance contract

**IMPORTANT:** Before performing any service or maintenance procedures, see the "Safety Information" section at the front of this manual.

### **WARNING**

**Units with circuit breaker(s) meet requirements as a service disconnect switch, however, if access is required to the line side (covered) of the circuit breaker, this side of the breaker(s) will be energized with the breaker(s) de-energized. Contact with the line side can cause electrical shock resulting in personal injury or death.**

### 12.1 AIR FILTER (NOT FACTORY-INSTALLED)

Check the system filter every ninety days or as often as found to be necessary and if obstructed, clean or replace at once.

#### **FILTER MAINTENANCE**

Have your qualified installer, service agency or HVAC professional instruct you on how to access your filters for regular maintenance.

**IMPORTANT:** Do not operate the system without a filter in place.

- New filters are available from your local distributor.

## 12.2 INDOOR COIL - DRAIN PAN - DRAIN LINE

Inspect the indoor coil once each year for cleanliness and clean as necessary. In some cases, it may be necessary to remove the filter and check the return side of the coil with a mirror and flashlight.

**IMPORTANT:** Do not use caustic household drain cleaners, such as bleach, in the condensate pan or near the indoor coil. Drain cleaners will quickly damage the indoor coil.

## 12.3 BLOWER MOTOR AND WHEEL

Inspect the blower motor and wheel for cleanliness. It should be several years before it would become necessary to clean the blower motor and wheel.

- If it becomes necessary to remove the blower assembly from the unit, see instructions on removal and disassembly of motor, blower and heater parts.
- The blower motor and wheel may be cleaned by using a vacuum with a soft brush attachment. Remove grease with a mild solvent such as hot water and detergent. Be careful not to disturb the balance weights (clips) on the blower wheel blades. Do not drop or bend wheel as balance will be affected.

## 12.4 LUBRICATION

The blower motor sleeve bearings are pre-lubricated by the motor manufacturer and do not have oiling ports. Motor should be run for an indefinite period of time without additional lubrication.

## 12.5 BLOWER ASSEMBLY REMOVAL AND REPLACEMENT

Removing the blower assembly is not required for normal service and maintenance. Removal is necessary for replacement of defective parts such as motor, blower wheel. After extended use, removal of the blower assembly may become necessary for a thorough cleaning of the blower motor and wheel.

### **WARNING**

**If removal of the blower assembly is required, all disconnect switches supplying power to the equipment must be de-energized and locked (if not in sight of unit) so the field power wires can be safely removed from the blower assembly. Failure to do so can cause electrical shock resulting in personal injury or death.**

- Mark field power supply wiring (for replacement) attached to terminal block or circuit breaker(s) on blower assembly. Remove wiring from terminal block or circuit breaker(s).
- Mark low voltage control wiring (for replacement) where attached to unit control pig-tails on right side of blower housing. Remove wire nuts attaching field control wiring to unit control pigtails.
- Remove 4 screws holding blower assembly to front channel of cabinet and pull blower assembly from cabinet.
- To replace blower assembly, slide blower assembly into blower deck. Make sure blower assembly engages lances in deck properly. If assembly hangs up, check to make sure top and bottom are lined up in proper locations.
- Slide blower assembly to back of cabinet and make sure it is completely engaged.
- Replace 4 screws holding blower assembly to front channel of cabinet. Take care not to strip screws, just snug into place.
- Replace low voltage control wiring with wire nuts and make sure wiring is to wiring diagram and a good connection has been made.
- Replace field power wiring to terminal block or circuit breaker(s) on control area of blower assembly. Make sure wires are replaced as they were, check wiring diagram if necessary. Tighten supply power wiring securely to terminals lugs.
- Make sure wiring is within cabinet and will not interfere with access door. Make sure proper separation between low voltage control wiring and field power wiring has been maintained.
- Replace blower assembly control access panel before energizing equipment.

## 12.6 MOTOR REPLACEMENT

With the blower assembly removed, the indoor blower motor can be removed and replaced using the following procedure:

- Remove motor leads from the motor capacitor and blower relay. Note lead locations for ease of reassembly. Pull leads from plastic bushing in blower side.
- Loosen the set screw holding blower wheel onto the motor shaft. Shaft extends through blower hub so that a wrench can be used on the extended shaft to break the shaft loose if necessary. Be careful not to damage shaft. A wheel puller can be used on the groove in the blower hub if necessary.
- Remove 4 metal screws holding motor mounts to blower side and remove motor from blower assembly.
- To install new motor, remove 1 screw holding motor mounts to motor shell and remove mounts (four) from motor.
- Install (four) motor mounts to motor using same screw or screws supplied with replacement motor.

### **WARNING**

**To avoid electrical shock which can result in personal injury or death, use only the screws furnished in the motor shell mounting holds. Screws are #8-18 x .25 in. long blunt nose thread forming. Screws longer than 1/4 in. may contact the motor winding.**

- To reassemble, insert motor shaft through hub in blower wheel and orient motor to original position with motor leads and motor label to front of blower (control area).
- Reassemble 12 sheet metal screws through motor mounts into blower side. Do not overtorque screws, blower side is light gage sheet metal, just snug screws tight enough to hold motor mounts in position.
- Turn motor shaft so that flat on shaft is located under blower wheel setscrew, and blower wheel is centered in blower housing with the same distance on each side between the inlet venturi and outside of blower wheel. Tighten setscrew on motor shaft. Turn wheel by hand to make sure it runs true without hitting blower sides.
- Reassemble motor wiring to capacitor and blower relay making sure that wires match wiring diagram and are tight and secure.

## 12.7 BLOWER WHEEL REPLACEMENT

With the blower assembly removed and the motor assembly removed (see above instructions), remove the 4 screws holding the blower wrap (cutoff) to the blower sides.

- With wrap (cutoff) screws removed, cut off end of blower wrap will spring up. Lifting wrap blower wheel is removed through the discharge opening in the blower housing.
- To replace, make sure wheel is oriented properly with hub to the opposite side from the motor. Lift blower wrap and insert blower wheel through discharge opening in the blower housing.
- Hold blower wrap down into position and replace two screws holding blower wrap to blower sides.
- See motor replacement and blower assembly instructions for remaining assembly procedure.

---

## 13.0 REPLACEMENT PARTS

Any replacement part used to replace parts originally supplied on equipment must be the same as or an approved alternate to the original part supplied. The manufacturer will not be responsible for replacement parts not designed to physically fit or operate within the design parameters the original parts were selected for.

These parts include but are not limited to: Circuit breakers, heater controls, heater limit controls, heater elements, motor, motor capacitor, blower relay, control transformer, blower wheel, filter, indoor coil and sheet metal parts.

When ordering replacement parts, it is necessary to order by part number and include with the order the complete model number and serial number from the unit data plate. (See parts list for unit component part numbers).

## 14.0 ACCESSORIES-KITS-PARTS

- **Combustible Floor Base RXHB-** for downflow applications.

Model Cabinet Size	Combustible Floor Base Model Number
17	RXHB-17
21	RXHB-21
24	RXHB-24

- **Jumper Bar Kit 3 Ckt. to 1 Ckt. RXBJ-A31** is used to convert single phase multiple three circuit units to a single supply circuit. Kit includes cover and screw for line side terminals.
- **Jumper Bar Kit 2 Ckt. to 1 Ckt. RXBJ-A21** is used to convert single phase multiple two circuit units to a single supply circuit. Kit includes cover and screw for line side terminals.

**NOTE:** No jumper bar kit is available to convert three phase multiple two circuit units to a single supply circuit.

- **External Filter Base RXHF- (See Figure 18)**

Model Cabinet Size	Filter Size	Part Number	A	B	
17	16 x 20 [406 x 508]	RXHF-17	Accommodate	15.70	17.50
21	20 x 20 [508 x 508]	RXHF-21	1" or 2" filter	19.20	21.00
24	25 x 20 [635 x 508]	RXHF-24		22.70	25.50

- **External Filter Rack: RXHF-B (See Figure 19)**

**FIGURE 18**  
EXTERNAL FILTER BASE: RXHF-

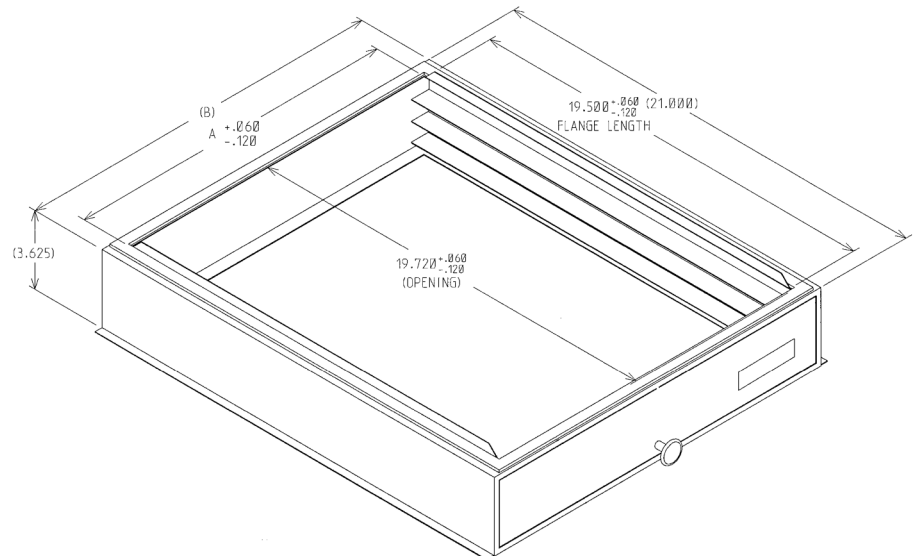

Model Cabinet Size	Filter Size	Part Number	A	B	
17	16 x 20	RXHF-B17	Accommodate	16.90	20.77
21	20 x 20	RXHF-B21	1" filter	20.40	20.77
24	25 x 20	RXHF-B24		25.00	21.04

**FIGURE 19**  
**EXTERNAL FILTER RACK: RXHF- B17, B21, B24**

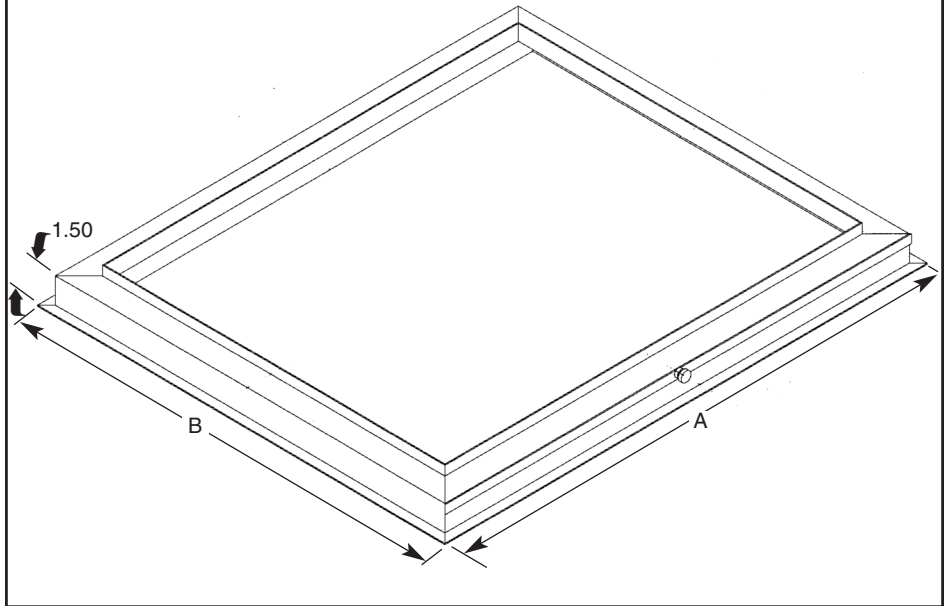

- **Horizontal Adapter Kit RXHH-**

This horizontal adapter kit is used to convert Upflow/Downflow only models to horizontal flow. See the following table to order proper horizontal adapter kit.

Coil Model	Horizontal Adapter Kit Model Number (Single Qty.)	Horizontal Adapter Kit Model Number (10-pak Qty.)
2414	RXHH-A01	RXHH-A01x10
2417	RXHH-A02	RXHH-A02x10
3617/3621	RXHH-A03	RXHH-A03x10
4821/4824	RXHH-A04	RXHH-A04x10
6024	RXHH-A05	RXHH-A05x10

- **Auxiliary Horizontal Overflow Pan RXBM-**

Nominal Cooling Capacity Tons	Auxiliary Horizontal Overflow Pan Accessory Model Number
1½ - 3	RXBM-AC48
3½ - 5	RXBM-AC61

