



## Demand Duo™ H-Series

### Commercial Hybrid Water Heating System Installation and Operation Manual

#### **For Indoor Commercial Applications Only:**

#### **Single Tankless H-Series Demand Duo™**

This product is **NOT** intended for residential applications.

CHS13080HiN	.....80 Gallon, 130,000 BTU
CHS13080HiP	.....80 Gallon, 130,000 BTU
CHS16080HiN	.....80 Gallon, 160,000 BTU
CHS16080HiP	.....80 Gallon, 160,000 BTU
CHS19980HiN	.....80 Gallon, 199,000 BTU
CHS19980HiP	.....80 Gallon, 199,000 BTU
CHS160100HiN	.....100 Gallon, 160,000 BTU
CHS160100HiP	.....100 Gallon, 160,000 BTU

**WARNING**

**If the information in these instructions is not followed exactly, a fire or explosion may result causing property damage, personal injury, or death.**

- Do not store or use gasoline or other flammable vapors and liquids in the vicinity of this or any other appliance.
- WHAT TO DO IF YOU SMELL GAS
  - Do not try to light any appliance.
  - Do not touch any electrical switch; do not use any phone in your building.
  - Immediately call your gas supplier from a neighbor's phone. Follow the gas supplier's instructions.
  - If you cannot reach your gas supplier, call the fire department.
- Installation and service must be performed by a trained and qualified professional, service agency or the gas supplier.

# Contents

1. Welcome .....	4
2. Safety .....	5
2.1 Safety Symbols .....	5
2.2 Safety Precautions .....	5
3. About .....	7
3.1 Components .....	7
3.2 Specifications .....	8
3.3 Dimensions .....	10
4. Installation .....	12
4.1 Installation Guidelines .....	12
4.2 What You Will Need .....	13
4.3 Choose an Installation Location .....	13
5. Venting .....	17
5.1 Venting Requirements .....	17
5.2 Select a Vent Type .....	19
6. System Plumbing .....	37
6.1 Pressure Relief Valve Requirements .....	37
6.2 Temperature-PRV Requirements .....	37
6.3 Typical Installations .....	38
6.4 Piping Diagram for Basic Installations .....	40
6.5 Piping Diagram for Multiple Unit Installations .....	41
6.6 Connect the Water Heater to the Water Supply .....	42
7. Gas and Power Supply .....	43
7.1 Connect the Gas Supply .....	43
7.2 Connect Electricity .....	46
7.3 Pump Controller .....	48
8. Post-Installation Checklist .....	49
9. Maintenance .....	50
10.1 Replacement Parts .....	51
10.2 Service/Maintenance Log .....	53
10. Warranty .....	54

**READ AND SAVE THESE INSTRUCTIONS**

# 1. Welcome

Thank you for purchasing Rinnai's Demand Duo™ H-Series Commercial Hybrid Water Heating System. This manual provides information on the installation, operation, and maintenance of Rinnai's Demand Duo™ H-Series Commercial Hybrid Water Heating System. Read this manual completely before installing or operating the system.

**This manual is a supplement to the Installation and Operation Manual for Condensing Tankless Water Heaters; refer to the tankless water heater installation and operation manual for complete water heater details, including:**

- Parameter Settings (High Altitude Adjustment, Vent Length Adjustment, and more)
- Temperature Controller Installation
- Performance Data
- Diagnostic Codes

## To The Installer

- A trained and qualified professional must install the system, inspect it, and leak test it before use. The warranty may be voided due to any improper installation.
- The trained and qualified professional should have skills such as:
  - Gas line sizing
  - Connecting gas lines, water lines, valves, and electricity
  - Knowledge of applicable national, state, and local codes
  - Installing venting through a wall or roof
  - Training in installation of tankless water heaters. Training on Rinnai Tankless Water Heaters is accessible at [www.trainingevents.rinnai.us](http://www.trainingevents.rinnai.us).
- Read all instructions in this manual before installing the system. The system must be installed according to the exact instructions in this manual.
- Proper installation is the responsibility of the installer.
- When installation is complete, leave this manual with the system or give the manual directly to the consumer.

## To The Owner

- You must read the entire manual to properly operate the water heater and to have regular maintenance performed.
- Keep this manual for future reference.
- As when using any appliance generating heat, there are certain safety precautions you should follow. See the **Safety Precautions** section for detailed safety precautions.
- Be sure your water heater is installed by a trained and qualified professional.
- If installing in the state of Massachusetts, you must read the **Massachusetts State Gas Regulations** section in the tankless water heater installation and operation manual (supplied with tankless water heater).

## For Your Records

Dealer Name: \_\_\_\_\_

Dealer Phone #: \_\_\_\_\_

Purchase Date: \_\_\_\_\_

Tank Serial #: \_\_\_\_\_

System Serial #: \_\_\_\_\_

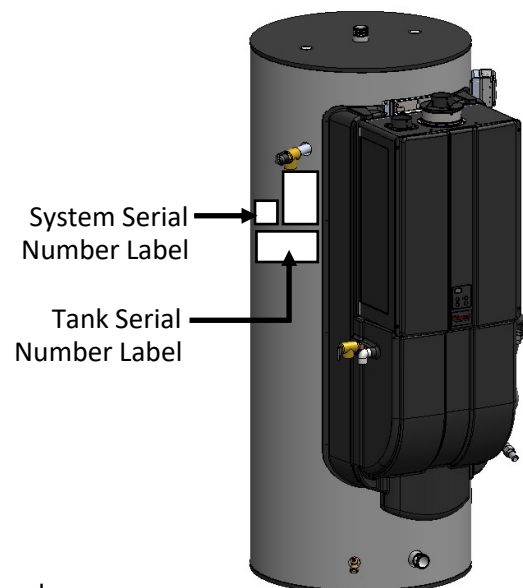

# 2. Safety

## Topics in this section

- Safety Symbols
- Safety Precautions

## 2.1 Safety Symbols

This manual contains the following important safety symbols. Always read and obey all safety messages.



This is the safety alert symbol. This symbol alerts you to potential hazards that can kill or hurt you and others.



**DANGER** Indicates an imminently hazardous situation which, if not avoided, will result in personal injury or death.



**WARNING** Indicates a potentially hazardous situation which, if not avoided, could result in personal injury or death.



**CAUTION** Indicates a potentially hazardous situation which, if not avoided, could result in minor or moderate injury. It may also be used to alert against unsafe practices.

## 2.2 Safety Precautions



### WARNING

- Before operating, smell all around the appliance area for gas. Be sure to smell next to the floor because some gas is heavier than air and will settle on the floor.
- Keep the area around the appliance clear and free from combustible materials, gasoline, and other flammable vapors and liquids.

- Combustible construction refers to adjacent walls and ceiling and should not be confused with combustible or flammable products and materials. Combustible and/or flammable products and materials should never be stored in the vicinity of this or any gas appliance.
- Always check the water temperature before entering a shower or bath.
- To protect yourself from harm, before performing maintenance:
  - Turn off the electrical power supply by unplugging the power cord or by turning off the electricity at the circuit breaker. (The “On/Off” button on the temperature controller does not control the electrical power.)
  - Turn off the gas at the gas valve, usually located immediately before the water heater.
  - Turn off the incoming water supply. This can be done at the isolation valve immediately before the water heater or by turning off the water supply to the building.
- Use only your hand to push in or turn the gas control knob. Never use tools. If the knob will not push in or turn by hand, do not try to repair it; call a licensed professional. Force or attempted repair may result in a fire or explosion.
- Do not use this appliance if any part has been under water. Immediately call a trained and qualified professional to inspect the appliance and to replace any part of the control system and any gas control which has been under water.
- Do not use substitute materials. Use only parts certified for the appliance.
- Should overheating occur or the gas supply fail to shut off, turn off the manual gas control valve to the appliance.
- Do not use an extension cord or an adapter plug with this appliance.
- Any alteration to the appliance or its controls can be dangerous and will void the warranty.
- If a water heater is installed in a closed water supply system, such as one having a backflow preventer in the cold water supply line, means shall be provided to control thermal expansion. Contact the water supplier or local plumbing inspector on how to control thermal expansion.

- Keep the air intake location free of chemicals such as chlorine or bleach that produce fumes. These fumes can damage components and reduce the life of your appliance.
- Make sure the water heater and its water lines are protected from freezing. Damage due to freezing is not covered by the warranty.

**! WARNING** DO NOT adjust the internal gas valve. The design is such that adjustment is not required. Warranty will be voided if the internal gas valve is adjusted.

- Only trained and qualified professionals are permitted to adjust parameter settings.
- Proper venting is required for the safe operation of this appliance.
- Flammable liquids such as cleaning solvents, aerosols, paint thinners, adhesives, gasoline and propane must be handled and stored with extreme care. These flammable liquids emit flammable vapors and when exposed to an ignition source can result in a fire hazard or explosion. Flammable liquids should not be used or stored in the vicinity of this or any other gas appliance.
- DO NOT operate the water heater without the front panel installed. The front panel should only be removed for service/maintenance or replacing internal components.
- BURN HAZARD. Hot exhaust and vent may cause serious burns. Keep away from the water heater. Keep small children and animals away from the water heater.
- Hot water outlet pipes leaving the water heater can be hot to touch.
- Do not store or use gasoline or other flammable vapors and liquids in the vicinity of this or any other appliance.
- Install the vent system per local and national codes.
- Do not install this water heater above 10,200 ft (3,109 m).
- Do not obstruct combustion air to the water heater.
- Failure to properly vent this appliance can result in death, personal injury and/or property damage.
- Rinnai recommends that every home have a carbon monoxide (CO) alarm inside or directly outside each bedroom or sleeping area. Check batteries monthly and replace them annually.

**! WARNING**

**FLAMMABLE**



Flammable Vapors

**FOR YOUR SAFETY**  
Do not store or use gasoline or other flammable vapors and liquids in the vicinity of this or any other appliance.

**! DANGER**



Hot water can be dangerous, especially for infants or children, the elderly, or infirm.

There is hot water scald potential if the thermostat is set too high.

Water temperatures over 125°F (51°C) can cause severe burns or scalding resulting in death.

Hot water can cause first degree burns with exposure for as little as:

- 3 seconds at 140°F (60°C)
- 20 seconds at 130°F (54°C)
- 8 minutes at 120°F (48°C)

Test the temperature of the water before placing a child in the bath or shower.

Do not leave a child or an infirm person in the bath unsupervised.

# 3. About

## Topics in this section

- Components
- Specifications
- Dimensions

## 3.1 Components

Figure 1: Components

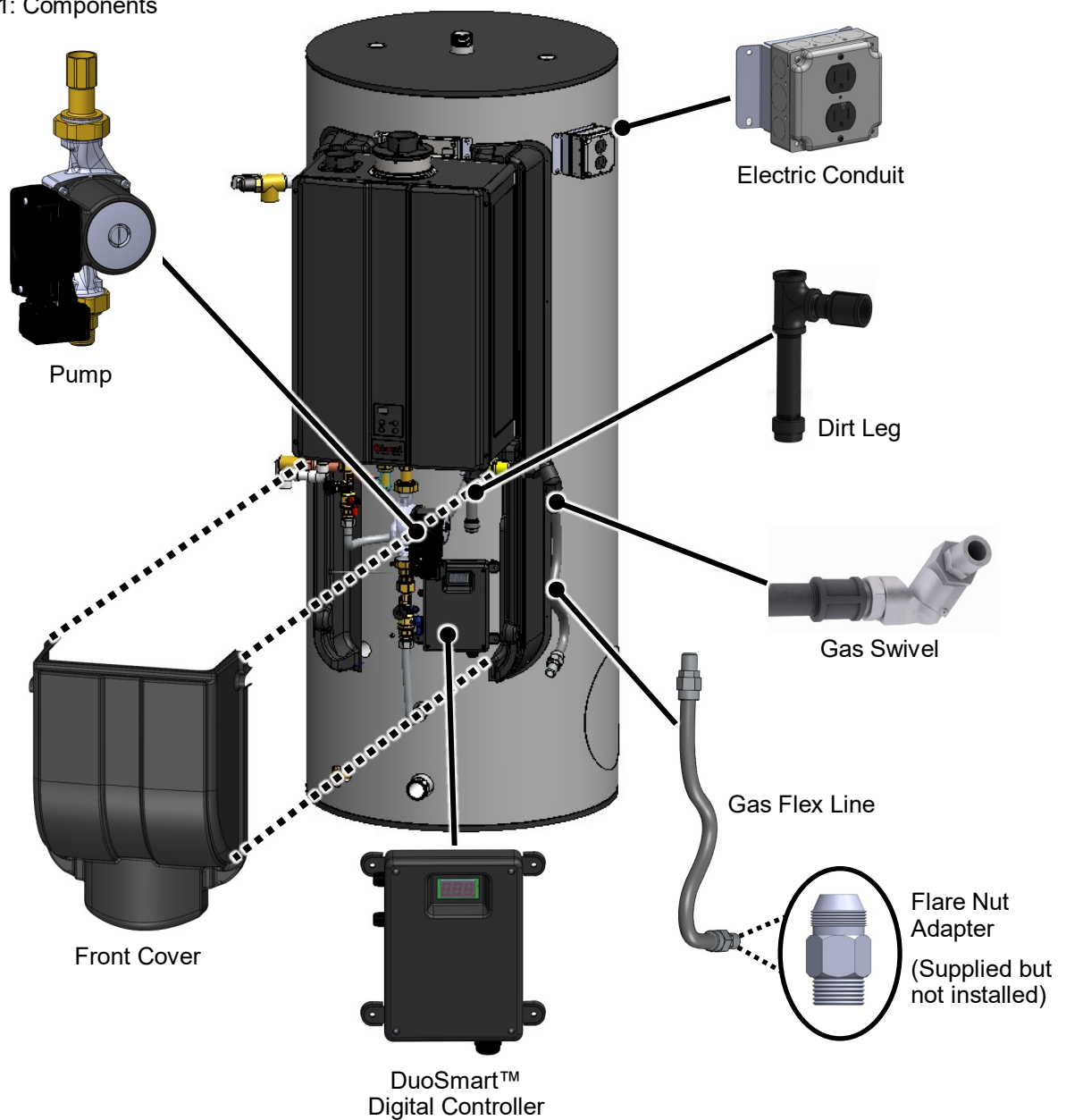

## 3.2 Specifications

Table 1: Specifications

Appliance Type	Commercial Hybrid Water Heating System Consisting of Condensing Tankless Water Heater, Insulated Storage Tank, Pump and Controller					
Model	CHS199100Hi	CHS160100Hi	CHS19980Hi	CHS16080Hi	CHS13080Hi	
Minimum Gas Consumption Btu/hr (kW/hr)	15,000 (4.3)					
Maximum Gas Consumption Btu/hr (kW/hr)	199,000 (58.3)	160,000 (46.9)	199,000 (58.3)	160,000 (46.9)	130,000 (38.1)	
Tank Volume	119 Gallons (450 Liters)		80 Gallons (303 Liters)			
First Hour Delivery at 100°F Rise <sup>1</sup>	317 Gallons (1,200 Liters)	271 Gallons (1,026 Liters)	290 Gallons (1,098 Liters)	244 Gallons (924 Liters)	209 Gallons (791 Liters)	
Product Weight	431 lb (195 kg)	429 lb (195kg)	307 lb (139 kg)	305lb (138 kg)	305lb (138 kg)	
Sound Level	49 dB	48 dB	49 dB	48 dB	48dB	
Installation Type	Internal (Indoor) Commercial Applications					
Category	Category IV					
Ignition System	Direct Electronic Ignition					
Water Supply Pressure	150 PSI (Maximum)					
Temperature Setting	98°F (37°C) to 185°F (85°C)				98°F (37°C) to 140°F (60°C) <sup>3</sup>	
Electrical Data	Normal	265 W	223 W	265 W	233 W	219 W
	Standby	44 W	44 W	44 W	44 W	44 W
	Freeze Protection	148 W	148 W	148 W	148 W	148 W
	Max Current	5.5 A	5.5 A	5.5 A	5.5 A	5.5 A
	Fuse	Tankless Water Heater Engine: 10 Amps, Controller: 10 Amps				
Gas Supply Pressure <sup>2</sup>	Natural	3.5 - 10.5 in. w.c.				
	Propane	8.0 - 13.5 in. w.c.				
By-Pass Flow Control	Electronic					
Connections	Gas Supply Inlet: 3/4 in. MNPT    Hot Water Outlet: 1-1/2 in. MNPT Cold Water Inlet: 1-1/2 in. MNPT					
Electric Connections	Appliance: AC 120 Volts, 60Hz. Integrated Temperature Controller: DC 12 Volts (Digital)					
Water Temperature Control	Simulation Feed Forward and Feedback					
ENERGY STAR® Certified (Tankless engine)	Yes					
Complies with South Coast Air Quality Management District 14 ng/J or 20 ppm NOx Emission Levels	Yes					

<sup>1</sup>First Hour Delivery Rating is a theoretical calculation based on 70% usable tank capacity (Tank Capacity x .70 + (recovery) = First Hour Delivery Rating

<sup>2</sup>The maximum gas supply pressure must not exceed the value specified by the manufacturer.

<sup>3</sup>Temperature limit of 185°F can be achieved using optional MCC-91 controller.

Rinnai products are continually being updated and improved; therefore, specifications are subject to change without prior notice.

## 3.2.1 Recovery Capabilities

Table 2: Recovery Capacity / Input

Product Number	Gas Type	Input		U.S. Gallon / HR Liters / HR at Temperature Rise Indicated													
				Tank Capacity	°F	30°F	40°F	50°F	60°F	70°F	80°F	90°F	100°F	110°F	120°F	130°F	140°F
		BTU/HR	kW		°C	17°C	22°C	28°C	33°C	39°C	44°C	50°C	56°C	61°C	67°C	72°C	78°C
CHS199100Hi	NG/LP	199,000	58	119 Gals.	GPH	780	585	468	390	334	292	260	234	213	195	180	167
				450 Liters	LPH	2,953	2,214	1,771	1,476	1,264	1,105	984	886	806	738	681	632
CHS160100Hi	NG/LP	160,000	58	119 Gals.	GPH	627	470	376	314	269	235	209	188	171	157	145	134
				450 Liters	LPH	2,374	1,780	1,424	1,187	1,017	890	791	712	647	593	548	509
CHS19980Hi	NG/LP	199,000	58	80 Gals.	GPH	780	585	468	390	334	292	260	234	213	195	180	167
				303 Liters	LPH	2,953	2,214	1,771	1,476	1,264	1,105	984	886	806	738	681	632
CHS16080Hi	NG/LP	160,000	58	80 Gals.	GPH	627	470	376	314	269	235	209	188	171	157	145	134
				303 Liters	LPH	2,374	1,780	1,424	1,187	1,017	890	791	712	647	593	548	509
CHS13080Hi	NG/LP	130,000	58	80 Gals.	GPH	509	382	306	255	218	191	170	153	139	127	118	109
				303 Liters	LPH	1,929	1,446	1,157	964	827	723	643	579	526	482	445	413

# 3.3 Dimensions

## 3.3.1 Dimensions for 119 Gallon Models

Models
CHS199100Hi
CHS160100Hi

Measurements below are shown in inches (mm).

Figure 2: Dimensions

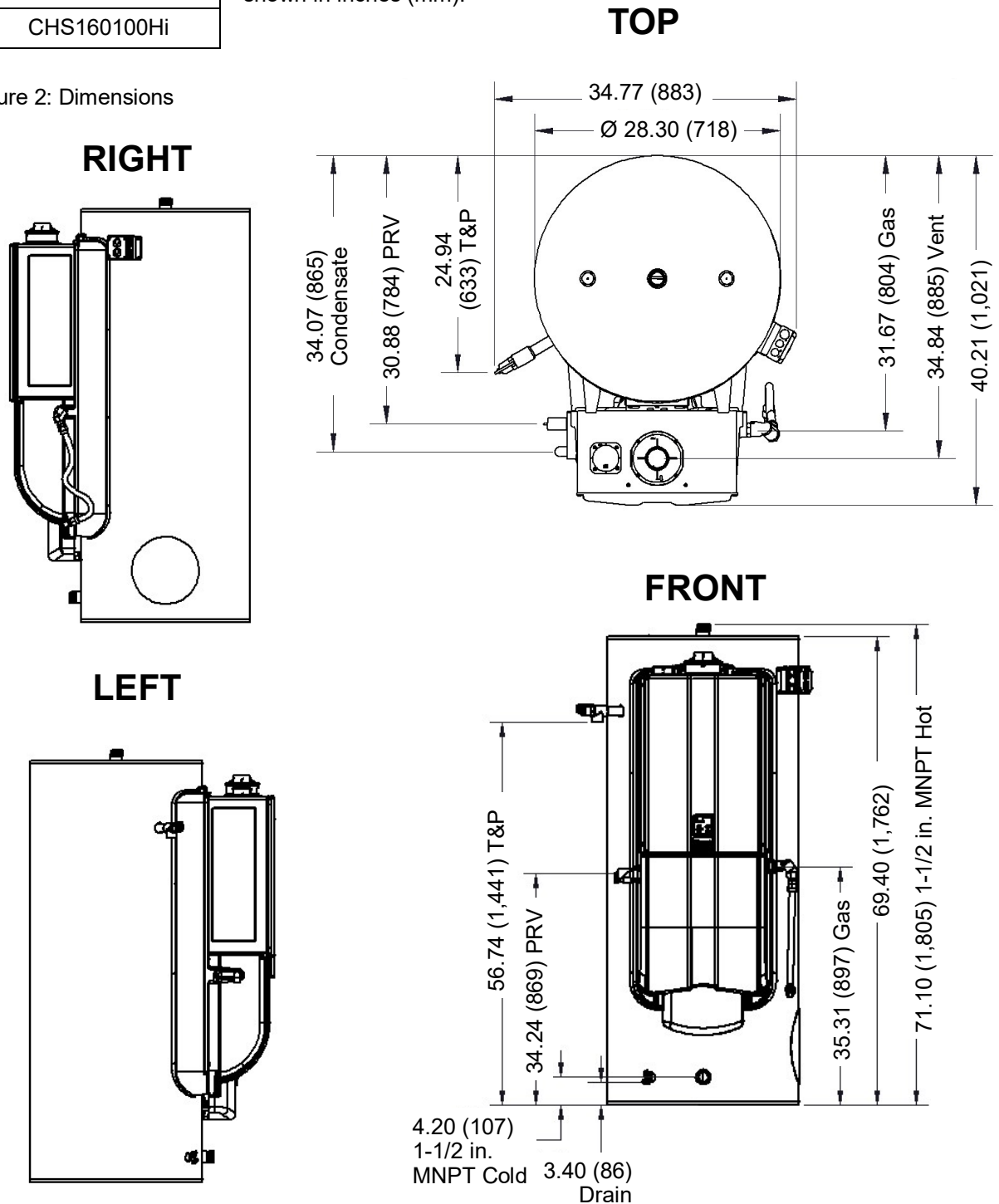

### 3.3.2 Dimensions for 80 Gallon Models

Models
CHS19980Hi
CHS16080Hi
CHS13080Hi

Measurements below are shown in inches (mm).

Figure 3: Dimensions

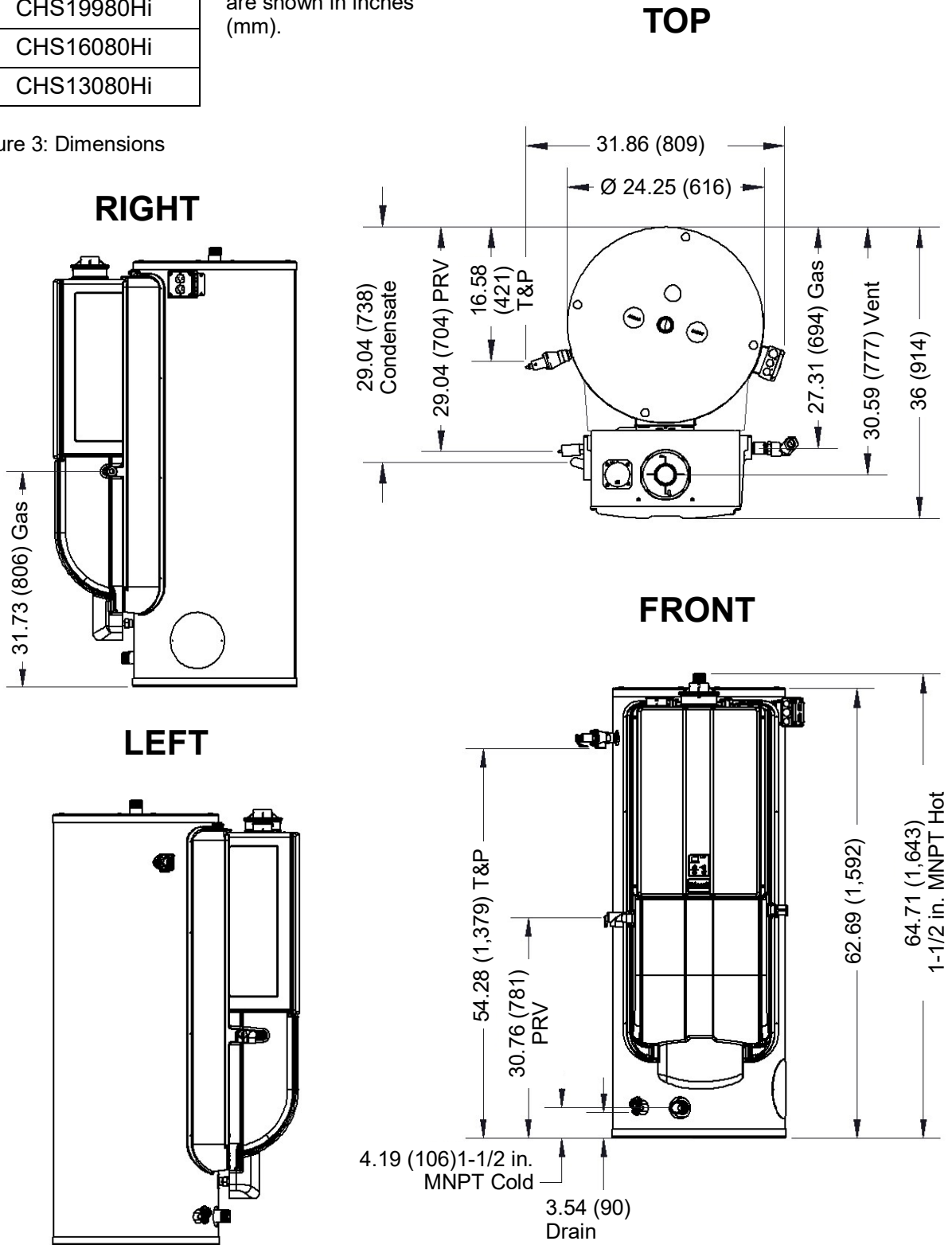

# 4. Installation

## Topics in this section

- Installation Guidelines
- What You Will Need
- Choose an Installation Location

### THIS SECTION IS INTENDED FOR THE INSTALLER







**Installer qualifications: A trained and qualified professional must install the appliance, inspect it, and leak test the Demand Duo™ before use. The warranty may be voided due to any improper installation. The trained and qualified professional should have skills such as: Gas sizing; Connecting gas lines, water lines, valves, and electricity; Knowledge of applicable national, state, and local codes; Installing venting through a wall or roof; and training in installation of tankless water heaters. Training for Rinnai Tankless Water Heaters is accessible online at [www.trainingevents.rinnai.us](http://www.trainingevents.rinnai.us).**

## 4.1 Installation Guidelines

When installing the Demand Duo™, follow these guidelines:

- This water heater is suitable for combination water heating and space heating and not suitable for space heating applications only.
- The installation must conform with local codes or, in the absence of local codes, with the *National Fuel Gas Code, ANSI Z223.1/NFPA 54*, or the *Natural Gas and Propane Installation Code, CSA B149.1*.
- The appliance, when installed, must be electrically grounded in accordance with local codes or, in the absence of local codes, with the *National Electrical Code, ANSI/NFPA 70*, or the *Canadian Electrical Code, CSA C22.1*.

- The appliance and its main gas valve must be disconnected from the gas supply piping system during any pressure testing of that system at test pressures in excess of 1/2 psi (3.5 kPa) (13.84 in W.C.). For system testing at pressures less than or equal to 1/2 psi (3.5 kPa) (13.84 in W.C.) the appliance must be isolated from the gas supply piping by closing its individual manual shutoff valve.
- You must follow the installation instructions and those in the venting section for adequate combustion air and exhaust.
- If a water heater is installed in a closed water supply system, such as one having a backflow preventer in the cold water supply line, means shall be provided to control thermal expansion. Contact the water supplier or local plumbing inspector on how to control thermal expansion.
- Should overheating occur or the gas supply fail to shut off, turn off the manual gas control valve to the appliance.
- Combustion air must be free of chemicals, such as chlorine or bleach, that produce fumes. These fumes can damage components and reduce the life of your appliance.

-  DO NOT install the Demand Duo™ Commercial Hybrid Water Heating System outdoors.
-  DO NOT install the water heater in an area where water leakage of the unit or connections will result in damage to the area adjacent to the appliance or to lower floors of the structure. When such locations cannot be avoided, it is required that a suitable drain pan, adequately drained, be installed under the water heater. The pan must not restrict combustion air flow.
-  DO NOT install the water heater in an area with negative air pressure.
-  DO NOT obstruct the flow of combustion and ventilation air.
-  DO NOT use this appliance in an application such as a pool or spa heater that uses chemically treated water. This appliance is suitable for filling large or whirlpool spa tubs with potable water.
-  DO NOT use substitute parts that are not authorized for this appliance.

## 4.2 What You Will Need

### 4.2.1 Items Included

Carefully unpack your system package and verify the following contents are included.

If any items are damaged or missing, contact your local dealer/distributor or call Rinnai Customer Care at 1-800-621-9419. Do not attempt to use any item that appears damaged.

Items included with system:

- Rinnai Demand Duo™ Commercial Hybrid Water Heating System
- Temperature and Pressure Relief Valve (pre-installed on tank)
- Pressure Relief Valve (pre-installed on the tankless water heater)
- Installation and Operation Manual (this manual)
- Installation and Operation Manual for Tankless Water Heater
- 2 in. PVC Vent Screens (x2) and Vent Screen Screws
- Gas Flex/Union



#### **WARNING**

To avoid danger of suffocation, keep plastic bags away from babies, small children and pets. Do not use these bags in cribs, beds, carriages, or playpens. The bags are not a toy.

### 4.2.2 Items Needed (Field-Supplied)

- Pipe wrenches (x2)
- Phillips Head screwdriver
- Adjustable pliers
- Wire cutters
- Gloves
- Safety glasses
- Level
- Soap or gas leak detector solution
- Approved venting
- Teflon tape (recommended) or pipe compound
- Pipe insulation

### 4.2.3 Items You May Need

- Hammer drill with concrete bits
- Saw

- Threading machine with heads and oiler
- Core drill with diamond head
- Torch set
- Copper tubing cutter
- Steel pipe cutter
- Heat tape
- 5/8 in. ID PVC flexible tubing
- Electrical wire
- Concrete wall anchors
- Optional pipe cover
- PVC glue/cement and primer
- 2 conductor 22 AWG wire for controller
- Single gang electrical box
- Wire nuts
- Unions and drain valves
- Drain pan
- Earthquake strap

## 4.3 Choose an Installation Location

When selecting an installation location, you must ensure that clearances will be met and that the vent length will be within required limits. Consider the installation environment, water quality, and need for freeze protection. Requirements for the gas line, water lines, electrical connection, and condensate disposal can be found in their respective installation sections in this manual.

### 4.3.1 Water Quality Guidelines

This section provides information on the importance of water quality to the Rinnai Tankless Water Heater. The information is intended to serve as general guidelines only and is not a complete list of water quality guidelines.

Consideration of care for your water heater should include evaluation of water quality. The water must be potable, free of corrosive chemicals, sand, dirt, or other contaminants. It is up to the installer to ensure the water does not contain corrosive chemicals or elements that can affect or damage the Rinnai Commercial Hybrid Water Heating System. Water that contains chemicals exceeding the levels below can damage the Rinnai Tankless Water Heater. Replacement of components due to water quality damage is not covered by the warranty.

Table 3: Water Quality Guidelines

Contaminant	Maximum Level
Total Hardness	Up to 200 mg/L
Aluminum *	Up to 0.2 mg/L
Chlorides *	Up to 250 mg/LL
Copper *	Up to 1.0 mg/L
Dissolved Carbon Dioxide (CO2)	Up to 15.0 mg/L
Iron *	Up to 0.3 mg/L
Manganese *	Up to 0.05 mg/L
pH *	6.5 to 8.5
TDS (Total Dissolved Solids) *	Up to 500 mg/L
Zinc *	Up to 5 mg/L

\* Source: Part 143 National Secondary Drinking Water Regulations

If you install this water heater in an area that is known to have hard water or that causes scale build-up, the water must be treated and may require a more frequent flushing schedule. This water heater includes a service indicator (Service Soon, SS). When selected in the parameter settings, an SS code will display on the controller indicating that it is time to flush and service the water heater. Scale build-up is caused by hard water and can be accelerated if the water heater is set at a temperature above 120°F.

Rinnai offers Southeastern Filtration’s “ScaleCutter Water Conditioning System” that offers superior lime scale prevention and corrosion control by feeding a blend of control compounds into the cold water supply.

### 4.3.2 Environment

Air surrounding the water heater, venting, and vent termination(s) is used for combustion and must be free of any compounds that cause corrosion of internal components. These include corrosive compounds that are found in aerosol sprays, detergents, bleaches, cleaning solvents, oil based paints/varnishes, and refrigerants. The air in beauty shops, dry cleaning stores, photo processing labs, and storage areas for pool supplies often contains these compounds. Therefore, it is recommended to install as a direct vent (use outside air for combustion). In applications utilizing room air where there are high levels of particulates, Rinnai offers a room air screen. The water heater, venting, and vent termination (s) should not be installed in any areas where the air may contain these corrosive compounds.

Do not store or use gasoline or other flammable vapors and liquids in the vicinity of this or any other appliance.

Flammable liquids such as cleaning solvents, aerosols, paint thinners, adhesives, gasoline and propane must be handled and stored with extreme care. These flammable liquids emit flammable vapors and when exposed to an ignition source can result in a fire hazard or explosion. Flammable liquids should not be used or stored in the vicinity of this or any other gas appliance.

### 4.3.3 Transport

1. Choose the right hand truck to support the weight and size of the water heater. Refer to section “3.2 Specifications” in this manual for specific weights and dimensions.
2. Use proper lifting techniques to load the water heater onto the hand truck:
  - Position the water heater onto the hand truck so the weight is evenly balanced and the tank is touching the rails of the hand truck.
  - Secure the water heater to the hand truck:
    - Position **STRAP A** around the tankless unit as illustrated below.
    - Position **STRAP B** around the base of the tank below the lower enclosure. Do not add strap around the exhaust or vent connection.

Figure 4: Transport

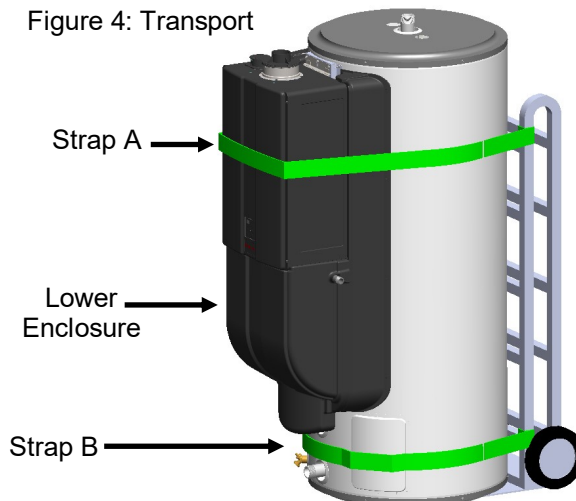

### 4.3.4 Clearances

Figure 5: Clearances

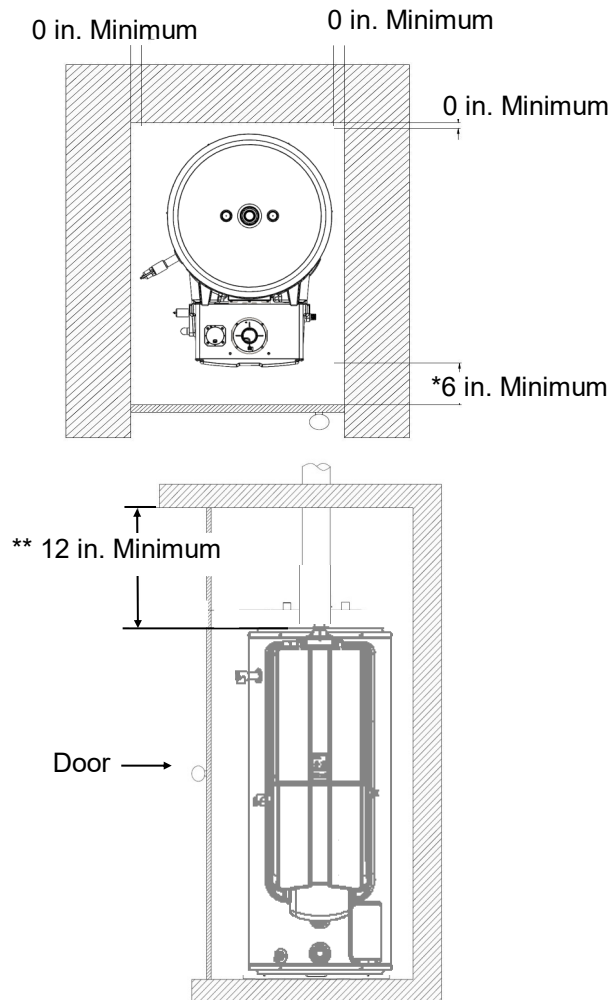

Table 4: Clearances

Location	Clearance
<b>Top</b>	2 in. (51 mm) (0 in. from vent components) ** Clearance for servicing the anode rods is 54 in. (137 cm) from the top of the water heater.
<b>Bottom (Ground)</b>	0 in.
<b>Front</b>	6 in. (152 mm) * Clearance for servicing is 24 in. (610 mm) in front of water heater.
<b>Back</b>	0 in.
<b>Sides (Left and Right)</b>	0 in.

### 4.3.5 Earthquake Strapping

**IMPORTANT**  
Product installed in the state of California must be braced, anchored, or otherwise secured to avoid motion or falling during an earthquake. Contact the California Office of the State Architect located at 1102 Q Street, Suite 5100, Sacramento, CA 95811 for instructions.

1. Loosen screws along the perimeter of the plastic enclosures.
2. Remove plastic enclosures.
3. Position straps around the tank per the requirements of California Office of the State Architect. **DO NOT POSITION THE STRAPS OVER PIPE, FITTINGS or WIRE.**
4. Replace the plastic enclosures. Modification of the plastic enclosures may be necessary to fit the enclosures over the earthquake straps.
5. Replace the screws around the perimeter of the plastic enclosures.

Figure 6: Earthquake Strapping

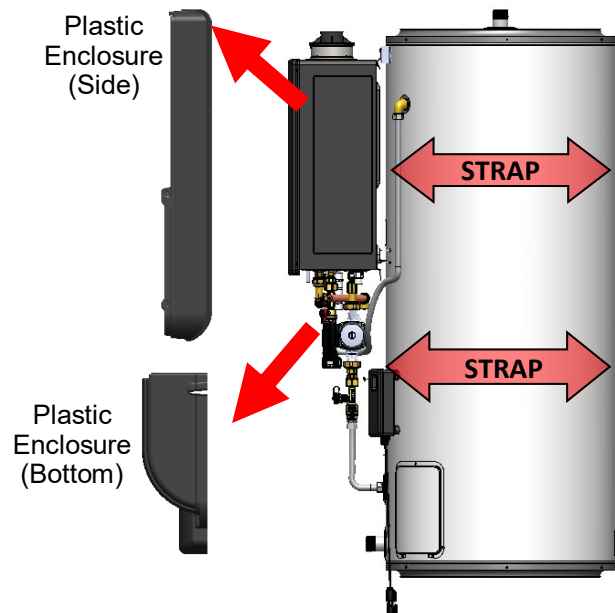

## 4.3.6 Installation Location Checklist

Use this checklist to ensure you have selected the correct location for the water heater.

<input type="checkbox"/>	The water heater is not exposed to corrosive compounds in the air.
<input type="checkbox"/>	The water heater location complies with the required clearances.
<input type="checkbox"/>	The planned combustion air and exhaust termination locations meet the required clearances.
<input type="checkbox"/>	The water supply does not contain chemicals or exceed total hardness that will damage the heat exchanger.
<input type="checkbox"/>	A standard 3 prong 120 VAC, 60 Hz properly grounded wall outlet or other 120 VAC, 60 Hz source is available.
<input type="checkbox"/>	The installation must conform with local codes or, in the absence of local codes, with the <i>National Fuel Gas Code, ANSI Z223.1/NFPA 54</i> , or the <i>Natural Gas and Propane Installation Code, CSA B149.1</i> .

# 5. Venting

## Topics in this section

- Venting Requirements
- Select a Vent Type

### ➔ IMPORTANT

For venting information not specified in this section, refer to the Installation and Operation Manual for Condensing Tankless Water Heaters (supplied with each tankless water heater). This manual includes complete venting information, including approved vent manufacturers and terminations.

## 5.1 Venting Requirements

- When installed as direct vent, refer to the Tankless Water Heater Installation and Operation Manual for a complete list of approved vent manufacturers and products. You must use vent components that are certified and listed with the water heater model.
  - Avoid dips or sags in horizontal vent runs by installing supports per the vent manufacturer's instructions.
  - Support horizontal vent runs every four feet and all vertical vent runs every six feet or in accordance with local codes.
  - Venting should be as direct as possible with a minimum number of pipe fittings.
  - Engineered vent systems must be firmly pressed together so that the gaskets form an air tight seal.
  - The vent piece connected to the water heater must be secured with one self-tapping screw.
  - When installed as Non-Direct Vent (Room Air), the venting must be Category IV and of a type listed by a national recognized testing agency or PVC (when allowed by local code).
- If the vent system is to be enclosed, it is suggested that the design of the enclosure shall permit inspection of the vent system. The design of such enclosure shall be deemed acceptable by the installer or the local inspector.
  - Refer to the instructions of the vent system manufacturer for component assembly instructions.

### ⚠ WARNING

- ❌ DO NOT use cellular core PVC/CPVC.
- ❌ DO NOT use Radel or galvanized material to vent this appliance.
- ❌ DO NOT cover non-metallic vent pipe and fittings with thermal insulation.
- ❌ DO NOT combine vent components from different manufacturers.
- ❌ DO NOT reduce the vent diameter.
- ❌ DO NOT connect the venting system with an existing vent or chimney.
- ❌ DO NOT common vent with the vent pipe of any other manufacturer's water heater or appliance.

### ➔ IMPORTANT

If it becomes necessary to access an enclosed vent system for service or repairs, Rinnai is not responsible for any costs or difficulties in accessing the vent system. The warranty does not cover obtaining access to a vent system in an enclosed environment.

## 5.1.1 Venting Installation Sequence

---

1. Install the water heater.
2. Determine the termination method — horizontal or vertical, concentric, or twin pipes, etc.
3. Determine proper location for wall or roof penetration for each termination.
4. Install termination assembly as described in this manual or in the vent manufacturer's installation instructions.
5. Install air and vent piping from water heater to termination.
6. Slope horizontal exhaust run towards the water heater 1/4 in per foot. DO NOT slope combustion air pipe towards water heater.
7. Install vent supports and brackets allowing for movement from expansion, or as per vent manufacturer's instructions or local code requirements.
8. Install vent screen (supplied with water heater) on PVC combustion air and exhaust termination elbows as illustrated below.
  - Press vent screen inside of termination piece/elbow.
  - Secure vent screen to the elbow with screw provided.

Figure 7: Vent Screen Assembly

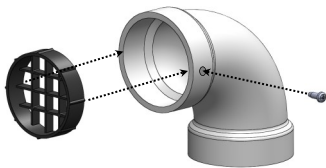

## 5.1.2 Termination Considerations

---

Check to determine whether local codes supersede the following clearances:

- Avoid termination locations near a dryer vent.
- Avoid termination locations near commercial cooking exhaust.
- Avoid termination locations near any air inlets.
- You must install a vent termination at least 12 in above the ground or anticipated snow level.

The vent for this appliance shall not terminate:

- Over public walkways.
- Near soffit vents or crawl space vents or other area where condensate or vapor could create a nuisance or hazard or cause property damage.
- Where condensate or vapor could cause damage or could be detrimental to the operation of regulators pressure relief valves, or other equipment.

Listed below are important considerations for locating vent termination under a soffit (ventilated or unventilated or eave vent; or to a deck or porch):

- Do not install vent termination under a soffit vent such that exhaust can enter the soffit vent.
- Install vent termination such that exhaust and rising moisture will not collect under eaves. Discoloration to the exterior of the building could occur if installed too close.
- Do not install the vent termination too close under the soffit where it could present recirculation of exhaust gases back into the combustion air part of the termination.

# 5.2 Select a Vent Type

Three types of venting options are available:

## 1 Direct Vent (Concentric Pipe and Twin Pipe)

### Concentric Pipe

Combustion air and exhaust vent directly through a single concentric connection. Hot exhaust exits through the interior tube, while combustion air enters through the outer layer.

Figure 8

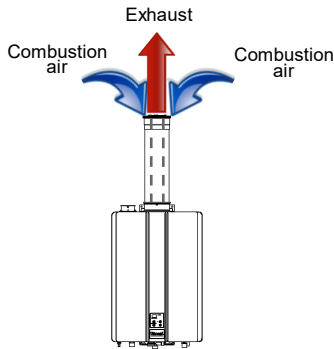

### Twin Pipe

Combustion air and exhaust vent directly through separate penetrations.

Figure 9

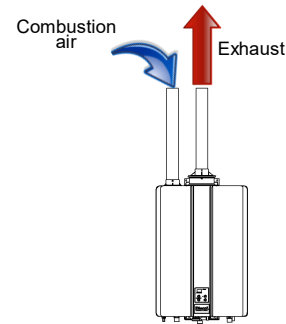

## 2 Non-Direct Vent (Room Air)

Room air is used for combustion while exhaust vents to the outside.

Figure 10

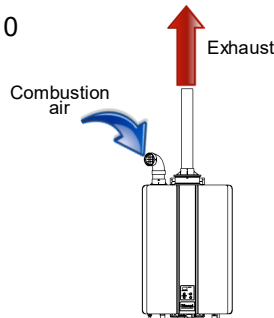

## 3 Common Vent (Indoor Units Only. Direct Vent and Non-Direct/Room Air Vent)

Figure 11

### Direct Vent

Multiple water heaters sharing a combustion air header and a separate exhaust header that vents directly through separate penetrations to

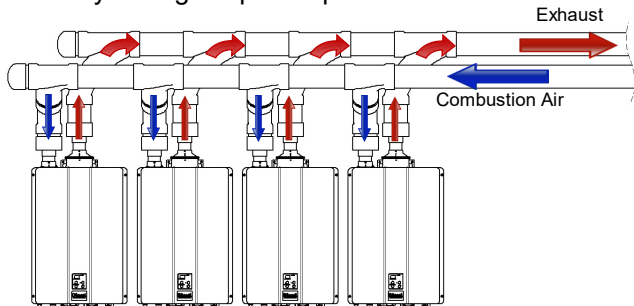
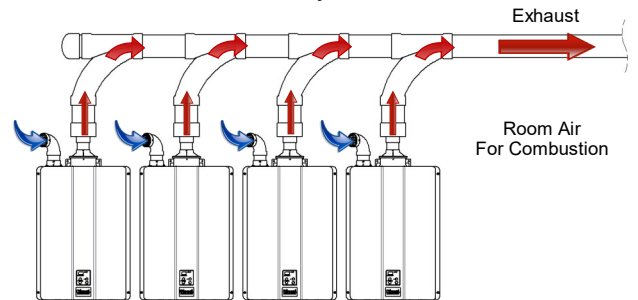

Figure 12

### Non-Direct (Room Air) Vent

Multiple water heaters using room air for combustion while sharing an exhaust header that vents directly to the outside.



# 1 Direct Vent (Concentric Pipe and Twin Pipe)

Figure 13: Direct Vent Termination Clearances (For Concentric and Twin Pipe)

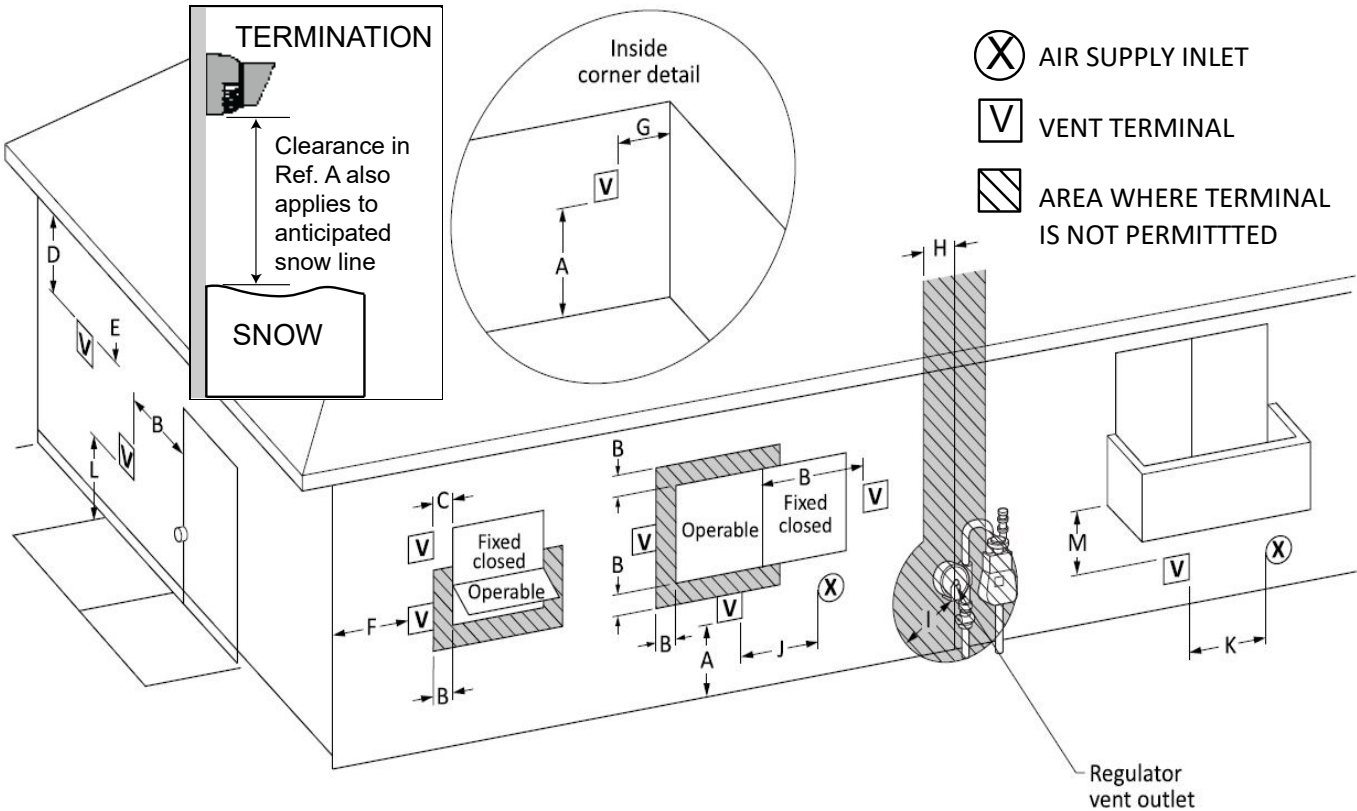

Ref	Description	Canadian Installations (CSA B149.1)	U.S. Installations (ANSI Z223.1 /NFPA 54)
		Direct Vent (Indoor Unit)	Direct Vent (Indoor Unit)
A	Clearance above grade, veranda, porch, deck, or balcony	12 in. (30 cm)	12 in. (30 cm)
B	Clearance to window or door that may be opened	36 in. (91 cm)	12 in. (30 cm)
C	Clearance to permanently closed window	*	*
D	Vertical clearance to ventilated soffit, located above the terminal within a horizontal distance of 2 ft (61 cm) from the center line of the terminal	*	*
E	Clearance to unventilated soffit	*	*
F	Clearance to outside corner	*	*
G	Clearance to inside corner	*	*
H	Clearance to each side of center line extended above meter/regulator assembly	*	*
I	Clearance to service regulator vent outlet	Above a regulator within 3 ft (91 cm) horizontally of the vertical center line of the regulator vent outlet to a maximum vertical distance of 15 ft (4 m)	*
J	Clearance to non-mechanical air supply inlet to building or the combustion air inlet to any other appliance	36 in. (91 cm)	12 in. (30 cm)
K	Clearance to a mechanical air supply inlet	6 ft (1.83 m)	3 ft (91 cm) above if within 10 ft (3 m) horizontally
L	Clearance above paved sidewalk or paved driveway located on public property	7 ft (2.13 m) [1]	*
M	Clearance under veranda, porch, deck, or balcony	12 in. (30 cm) [2]	*

Clearance to opposite wall is 24 in. (60 cm).

- [1] A vent shall not terminate directly above a sidewalk or paved driveway that is located between two single family dwellings and serves both dwellings.
- [2] Permitted only if veranda, porch, deck, or balcony is fully open on a minimum of two sides beneath the floor.

\* Clearances are in accordance with local installation codes and the requirements of the gas supplier. (*Dégagement conforme aux codes d'installation locaux et aux exigences du fournisseur de gaz.*)

# 1 Direct Vent (Concentric Pipe)

## Concentric Pipe Overview

Combustion air and exhaust vent directly through a single concentric connection. Hot exhaust exits through the interior tube, while combustion air enters through the outer layer.

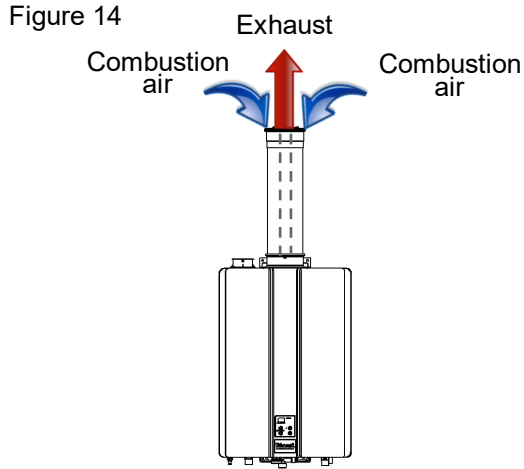

## Concentric Pipe Termination Clearances

Figure 15

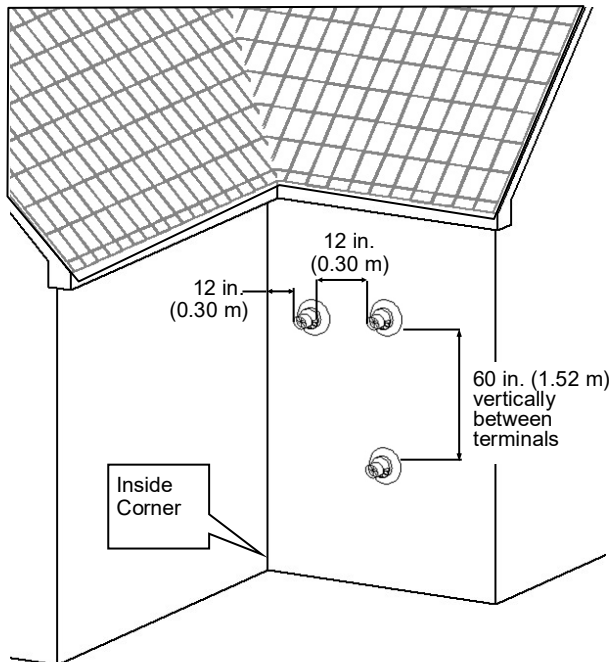

All terminations (horizontal and/or vertical) must terminate 12 in. (0.30 m) above grade or anticipated snow level.

Figure 16

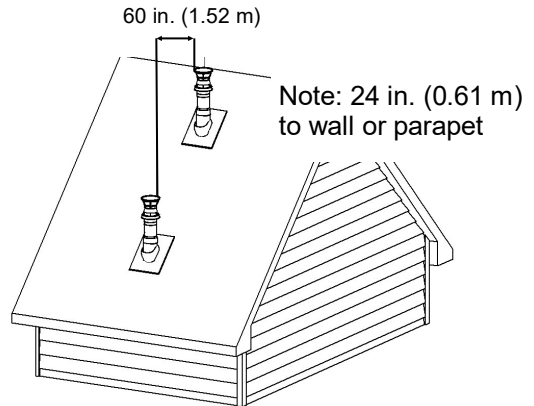

Between terminals at different levels

Figure 17

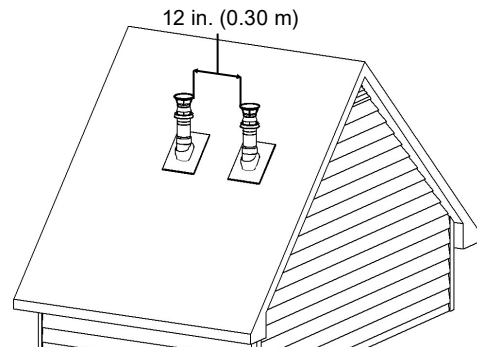

Between terminals at same level

# 1 Direct Vent *(Concentric Pipe)*

## Concentric Pipe Installation Instructions

1. Remove and discard screw from concentric flue connection.

Figure 18

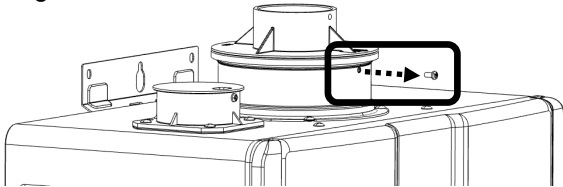

2. Remove exhaust adapter ring (discard for concentric venting configurations).

Figure 19

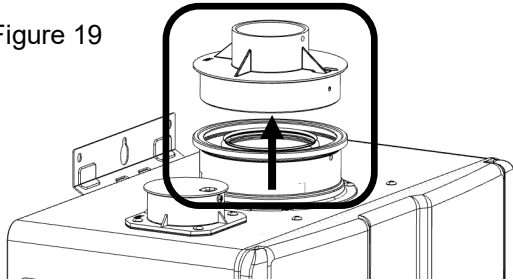

3. Install the concentric vent. Ensure it is properly seated.

Figure 20

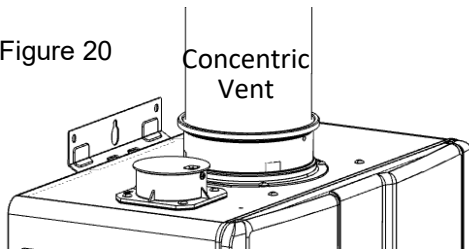

4. Secure the vent pipe to the concentric flue connection with the supplied screw.

Figure 21

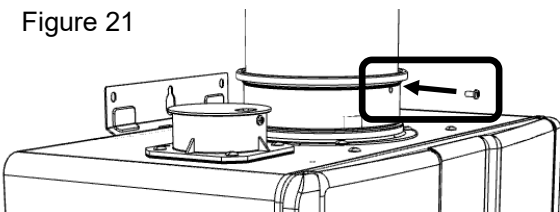

### ➔ IMPORTANT

Install the venting termination according to the diagrams and instructions in this manual. Slope the venting 1/4 in. per foot toward the appliance according to the vent manufacturer's installation instructions. Dispose of condensate per local codes.

## Concentric Pipe Example Vent Applications

Horizontal Wall Terminations	Vertical Roof Terminations
<p>2 in. x 4 in.</p>	<p>2 in. x 4 in. and 3 in. x 5 in.</p>
<p>3 in. x 5 in.</p>	

## Concentric Pipe Maximum Vent Length

Concentric Vent Maximum Equivalent Length		
Vent Sizes	2 in. X 4 in.	3 in. X 5 in.
Vent Lengths	65 ft (20 m)	150 ft (46 m)
<ul style="list-style-type: none"> <li>• 45° elbow is equivalent to 3 ft (1 m)</li> <li>• 90° elbow is equivalent to 6 ft (2 m)</li> </ul>		

# 1 Direct Vent (Twin Pipe)

## Twin Pipe Overview

Combustion air and exhaust vent directly through separate penetrations.

Figure 22

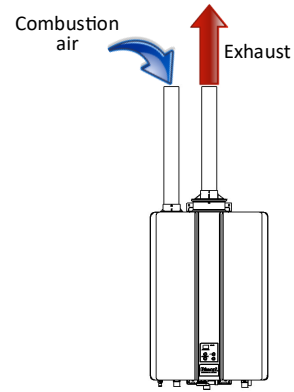

## Twin Pipe Termination Clearances

Figure 23

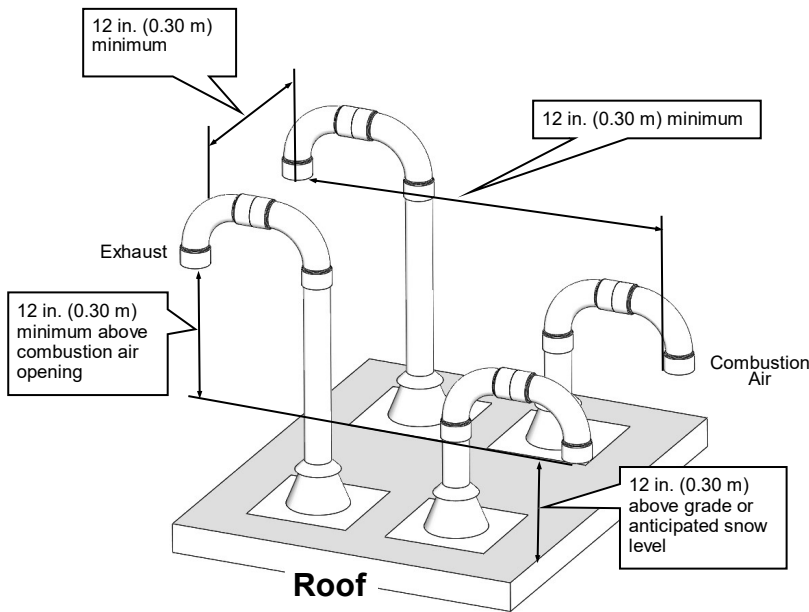

**Twin Pipe Vertical Termination of Multiple Water Heaters**

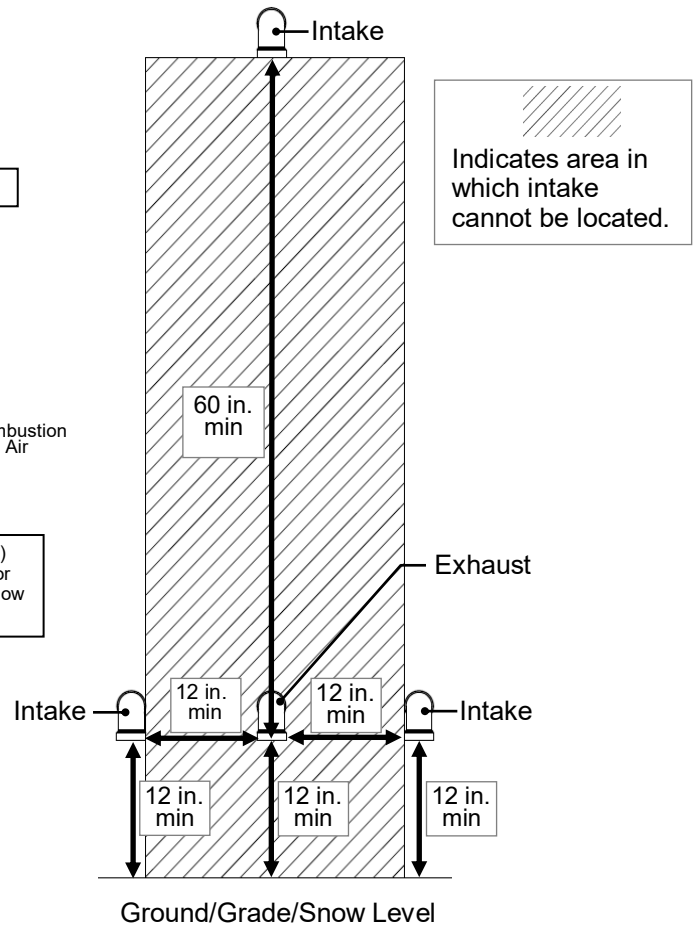

For illustration purposes only. Listed equivalent length is based on worst case scenario of 3 X 90° elbows or 18 equivalent ft.

# 1 Direct Vent (Twin Pipe)

## Twin Pipe Installation Instructions

The water heater is equipped with a 2 in. (51 mm) pipe connection. With the use of a pipe reducer, installers can use a 3 in. (76 mm) pipe for the combustion air and exhaust.

### **WARNING**

**DO NOT** apply PVC glues, solvents, or cleaners to the water heater's combustion air or exhaust gasket connections. Failure to correctly assemble the components according to these instructions may result in property damage, personal injury, or death.

1. Remove and discard the screw from the combustion air vent connection.

Figure 24

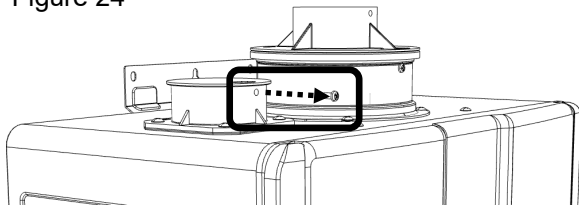

2. Remove and discard the combustion air vent cap.

Figure 25

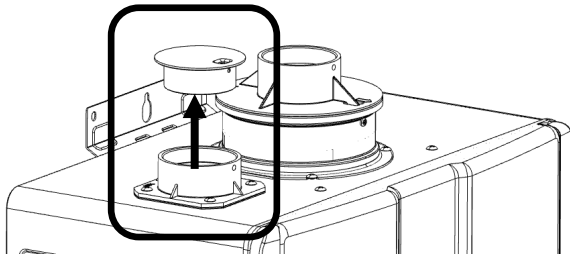

3. Install the combustion air vent pipe. Ensure it is properly seated. Secure the combustion air vent pipe to the combustion air vent connection with the supplied screw.

Figure 26

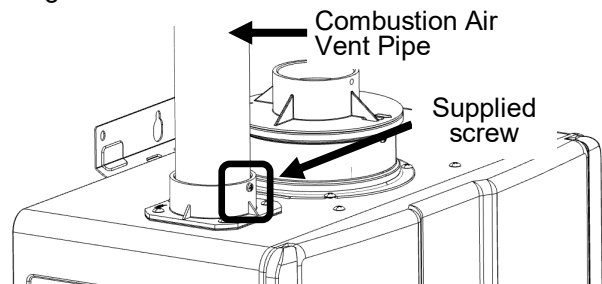

4. Install the exhaust vent pipe. Ensure it is properly seated.

Secure the exhaust vent pipe to the exhaust adapter ring with the supplied screw.

Figure 27

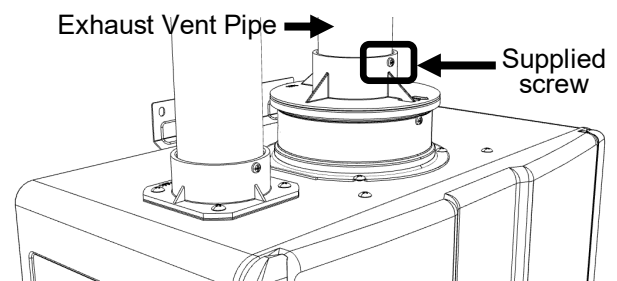

# 1 Direct Vent (Twin Pipe)

## Twin Pipe Example Vent Applications

Slope horizontal exhaust 1/4 in. per foot towards the water heater. DO NOT slope combustion air pipe towards the water heater.

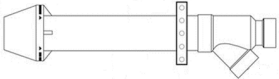
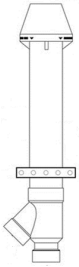
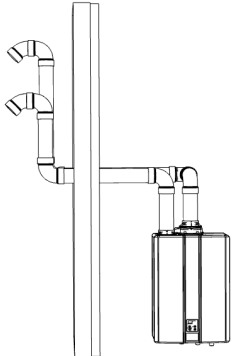
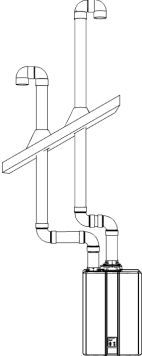
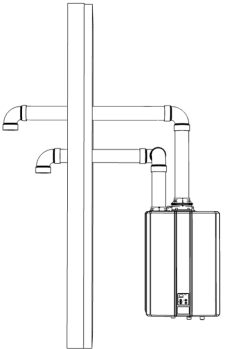
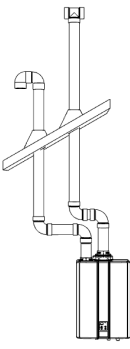
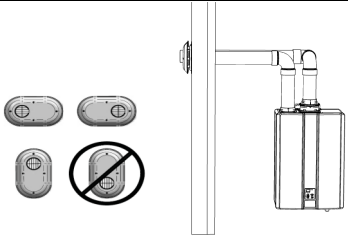
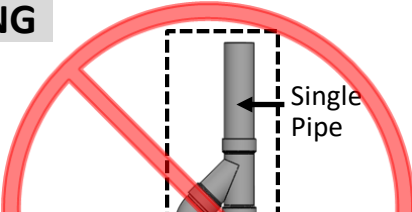
<p><b>This configuration requires the use of a Concentric Vent Termination</b></p> <p>2 in. or 3 in. PVC/CPVC IPEX / Royal Concentric Side Wall Termination Configuration</p> 	<p><b>This configuration requires the use of a Concentric Vent Termination</b></p> <p>2 in. or 3 in. PVC/CPVC IPEX / Royal Concentric Vertical Termination Configuration</p> 
<p>2 in. or 3 in. Schedule 40 PVC/CPVC or ABS Snorkel Termination Configuration</p> 	<p>2 in. or 3 in. Schedule 40 PVC/CPVC or ABS Standard upside down "U" Vertical Termination Configuration</p> 
<p>2 in. or 3 in. Schedule 40 PVC/CPVC or ABS Elbow or Tee Side Wall Termination Configuration</p> 	<p>2 in. or 3 in. Schedule 40 PVC/CPVC or ABS Tee Vertical Termination Configuration</p> 
<p>2 in. or 3 in. PVC Low Profile Termination Configuration</p> 	<p><b>WARNING</b></p> <p>Exhaust and combustion air <u>MUST NOT</u> be brought together into a single PVC pipe using a pipe fitting.</p> 

## Twin Pipe Maximum Vent Length

Twin Pipe Maximum Equivalent Length Table		
Vent Sizes	2 in. (51 mm)	3 in. (76 mm)
Vent Lengths	65 ft (20 m)	150 ft (46 m)
<ul style="list-style-type: none"> <li>45° elbow is equivalent to 3 ft (1 m)</li> <li>90° elbow is equivalent to 6 ft (1.83 m)</li> </ul>		

Figure 28: Room Air Termination Clearances

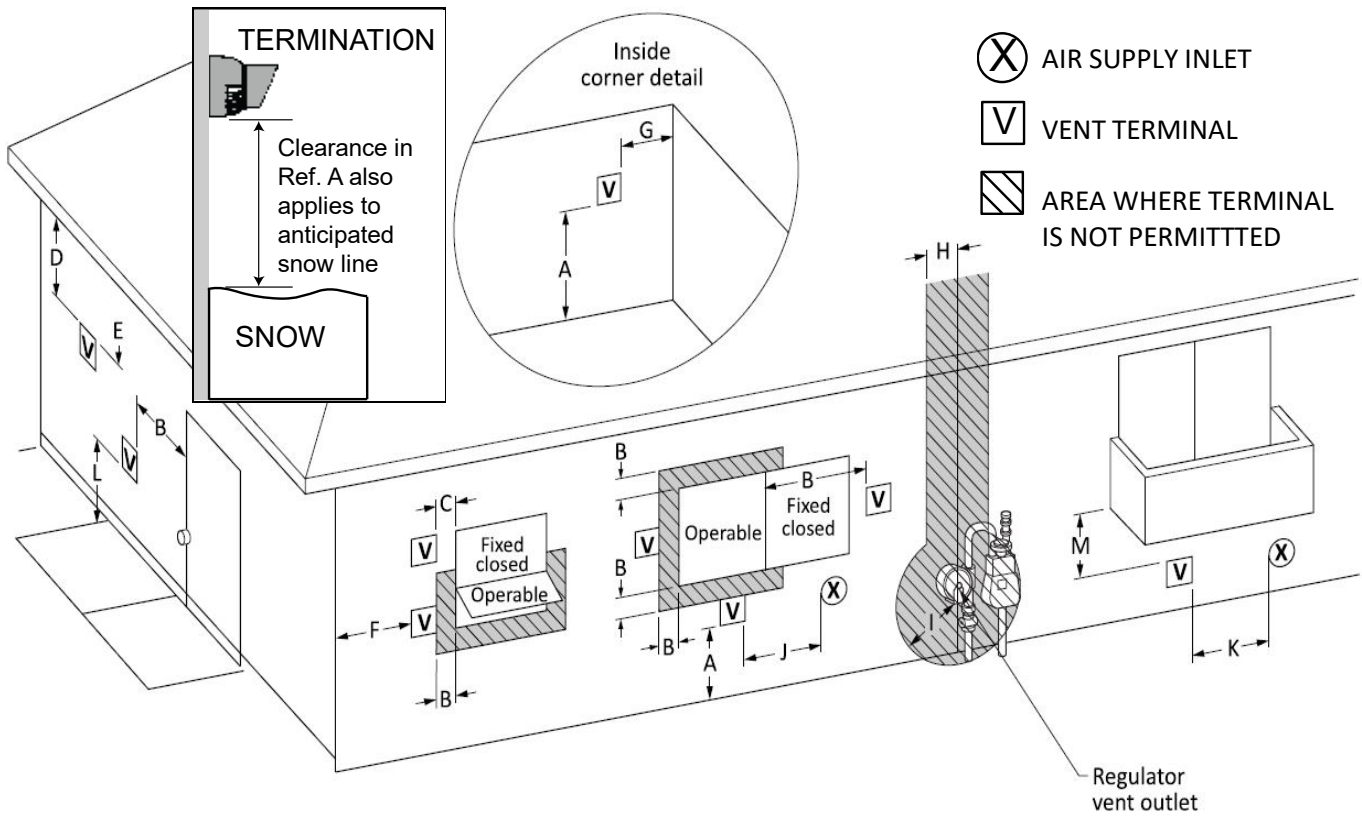

Ref	Description	Canadian Installations (CSA B149.1)	U.S. Installations (ANSI Z223.1 /NFPA 54)
		Other than direct vent (Outdoor unit and/or Room Air)	Other than direct vent (Outdoor unit and/or Room Air)
A	Clearance above grade, veranda, porch, deck, or balcony	12 in. (30 cm)	12 in. (30 cm)
B	Clearance to window or door that may be opened	36 in. (91 cm)	4 ft (1.2 m) below or to side of opening; 1 ft (300 mm) above opening
C	Clearance to permanently closed window	*	*
D	Vertical clearance to ventilated soffit, located above the terminal within a horizontal distance of 2 ft (61 cm) from the center line of the terminal	*	*
E	Clearance to unventilated soffit	*	*
F	Clearance to outside corner	*	*
G	Clearance to inside corner	*	*
H	Clearance to each side of center line extended above meter/regulator assembly	*	*
I	Clearance to service regulator vent outlet	Above a regulator within 3 ft (91 cm) horizontally of the vertical center line of the regulator vent outlet to a maximum vertical distance of 15 ft (4 m)	*
J	Clearance to non-mechanical air supply inlet to building or the combustion air inlet to any other appliance	36 in. (91 cm)	4 ft (1.2 m) below or to side of opening; 1 ft (300 mm) above opening
K	Clearance to a mechanical air supply inlet	6 ft (1.83 m)	3 ft (91 cm) above if within 10 ft (3 m) horizontally
L	Clearance above paved sidewalk or paved driveway located on public property	7 ft (2.13 m) [1]	*
M	Clearance under veranda, porch, deck, or balcony	12 in. (30 cm) [2]	*

Clearance to opposite wall is 24 in. (60 cm).

- [1] A vent shall not terminate directly above a sidewalk or paved driveway that is located between two single family dwellings and serves both dwellings.
- [2] Permitted only if veranda, porch, deck, or balcony is fully open on a minimum of two sides beneath the floor.

\* Clearances are in accordance with local installation codes and the requirements of the gas supplier. (*Dégagement conforme aux codes d'installation locaux et aux exigences du fournisseur de gaz.*)

## 2

### Non-Direct Vent (Room Air)

#### NOTE

- Installation of Non-Direct Vent (Room Air) must use listed category IV venting.
- All terminations (horizontal and/or vertical) must terminate 12 in. above grade or anticipated snow level.

### Exhaust Termination Clearances for Internal (Indoor) Room Air Applications

Figure 29

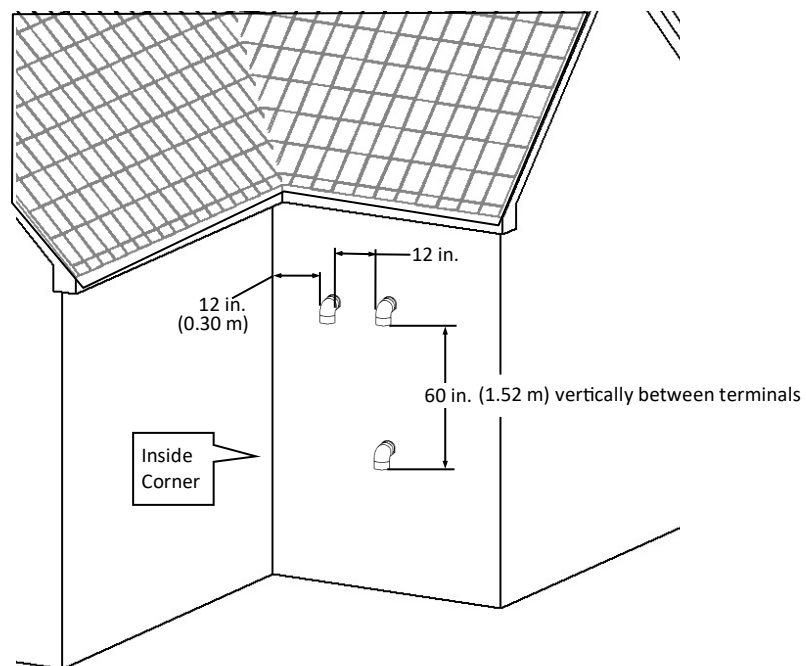

## 2

## Non-Direct Vent (Room Air)

### Combustion Air

#### **WARNING**

This water heater requires adequate combustion air for ventilation and dilution of flue gases. Failure to provide adequate combustion air can result in unit failure, fire, explosion, serious bodily injury or death. Use the following methods to ensure adequate combustion air is available for correct and safe operation of this water heater.

#### **IMPORTANT**

Combustion air must be free of corrosive chemicals. Do not provide combustion air from corrosive environments. Appliance failure due to corrosive air is not covered by warranty.

For applications containing corrosive indoor air, this appliance must be installed as direct vent. DO NOT use room air in applications where combustion air contains acid forming chemicals such as sulfur, fluorine and chlorine. These chemicals have been found to cause rapid damage and decay and can become toxic when used as combustion air in gas appliances. Such chemicals can be found in, but not limited to bleach, ammonia, cat litter, aerosol sprays, cleaning solvents, varnish, paint and air fresheners. Do not store these products or similar products in the vicinity of this water heater.

#### **Unconfined Space**

An unconfined space is defined in *National Fuel Gas Code, ANSI Z223.1/NFPA 54* as “a space whose volume is not less than 50 cubic feet per 1000 Btu/hr (4.8 m<sup>3</sup> per kW per hour) of the aggregate input rating of all appliances installed in that space. Rooms communicating directly with the space in which the appliances are installed, through openings not furnished with doors, are considered a part of the unconfined space.” If the “unconfined space” containing the appliance(s) is in a building with tight construction, additional outside air may be required for proper operation. Outside air openings should be sized the same as for a confined space.

#### **Confined Space**

A confined space is defined in the *National Fuel Gas Code, ANSI Z223.1/NFPA 54* as “a space whose volume is less than 50 cubic feet per 1000 Btu/hr (4.8 m<sup>3</sup> per kW per hour) of the aggregate input rating of all appliances installed in that space.” Examples include a small room, closet, alcove, utility room, etc. A confined space must have two combustion air openings. Size the combustion air openings based on the BTU input for all gas utilization equipment in the space and the method by which combustion air is supplied.

#### **Using Indoor Air For Combustion:**

When using air from other room(s) in the building, the total volume of the room(s) must be of adequate volume (Greater than 50 cubic feet per 1000 Btu/hr). Combustion air openings between joining rooms must have at least 1 square inch of free area for each 1000 Btu/hr, but not less than 100 square inches each.

#### **Using Outdoor Air For Combustion**

Outdoor air can be provided to a confined space through two permanent openings, one commencing within 12 in. (0.30 m) of the top and one commencing within 12 in. (0.30 m) of the bottom, of the confined space. The openings shall communicate to the outside by one of two ways.

When communicating directly with the outdoors through horizontal ducts, each opening shall have a minimum free area of 1 in<sup>2</sup>/2000 Btu/hr (1100 mm<sup>2</sup>/kW) of total input rating of all appliances in the confined space.

#### **NOTE**

If ducts are used, the cross sectional area of the duct must be greater than or equal to the required free area of the openings to which they are connected.

## 2

## Non-Direct Vent (Room Air)

### Combustion Air (Continued)

#### Louvers and Grills

When sizing the permanent opening consideration must be taken for the design of the louvers or grills to maintain the required free area required for all gas utilizing equipment in the space. If the free area of the louver or grill design is not available, assume wood louvers will have 25% free area and metal louvers or grills will have 75% free area. Under no circumstance should the louver, grill or screen have openings smaller than 1/4 in.

Free Area = Height x Length x % Free Area

Wood: 18 in. x 24 in. x 0.25 = 108 in.<sup>2</sup>

Metal: 18 in. x 24 in. x 0.75 = 324 in.<sup>2</sup>

Figure 30

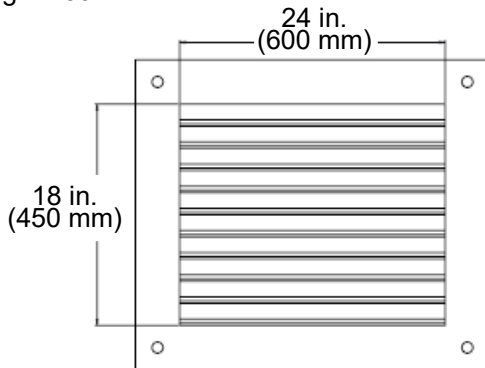

#### Location

To maintain proper circulation of combustion air two permanent openings (one upper, one lower) must be positioned in confined spaces. The upper shall be within 12 in. (0.30 m) of the top of the confined space and the lower opening shall be within 12 in. (0.30 m) of the bottom of the confined space. Openings must be positioned as to never be obstructed.



#### IMPORTANT

Combustion air provided to the appliance should not be taken from any area of the structure that may produce a negative pressure (i.e. exhaust fans, powered ventilation fans).



#### WARNING

TO PREVENT POSSIBLE PERSONAL INJURY OR DEATH DUE TO ASPHYXIATION, COMMON VENTING WITH OTHER MANUFACTURER'S INDUCED DRAFT APPLIANCES IS NOT ALLOWED.

## 2 Non-Direct Vent (Room Air)

Figure 31

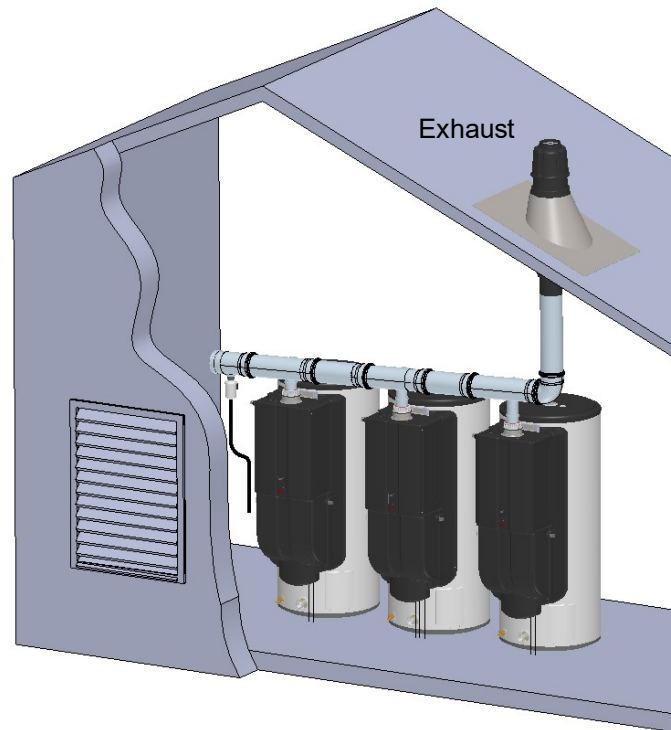

Vent termination per ANSI Z223.1/NFPA 54. For clearances not specified in ANSI Z223.1/NFPA 54, clearances are in accordance with local installation codes and the requirements of the gas supplier.

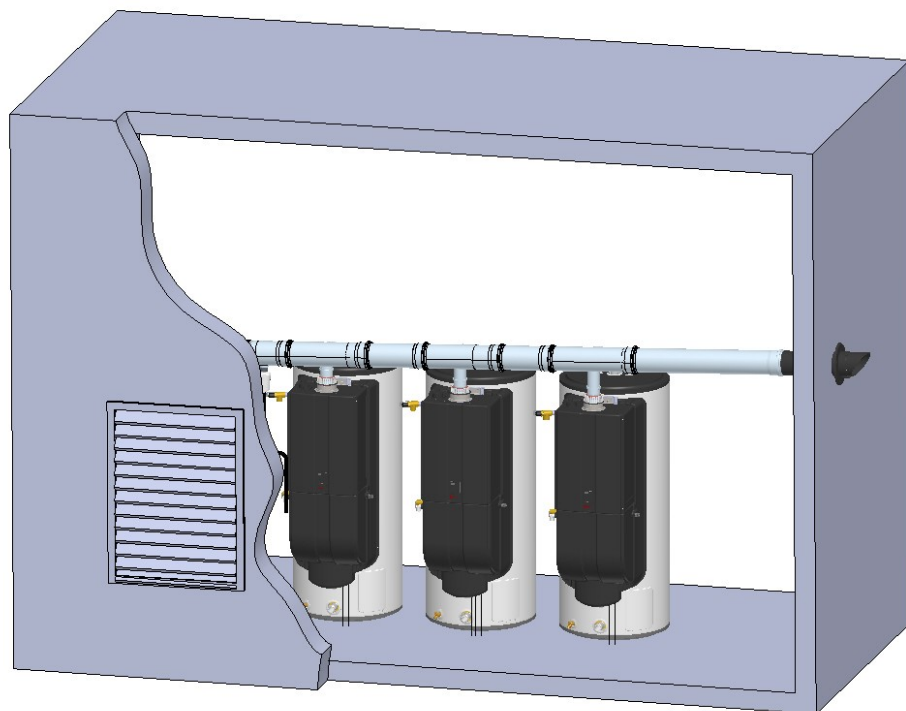

## 2 Non-Direct Vent (Room Air)

### Non-Direct Vent (Room Air) Installation Instructions

1. Remove and discard screw from combustion air vent connection.

Figure 32

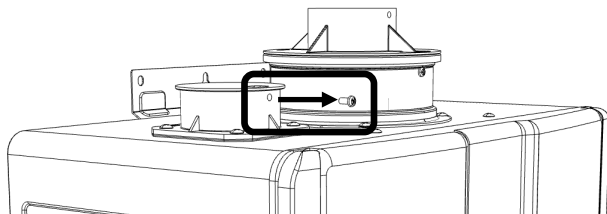

2. Remove and discard the combustion air vent cap.

Figure 33

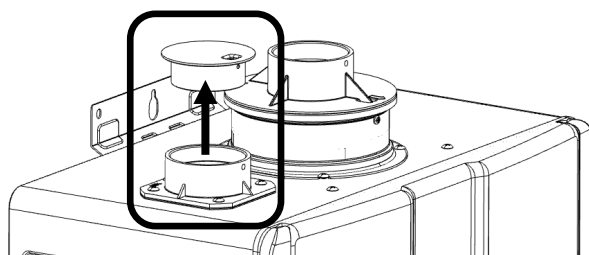

3. Install the combustion air vent pipe. Ensure it is properly seated.

Secure the combustion air vent pipe to the combustion air vent connection with the supplied screw.

Figure 34

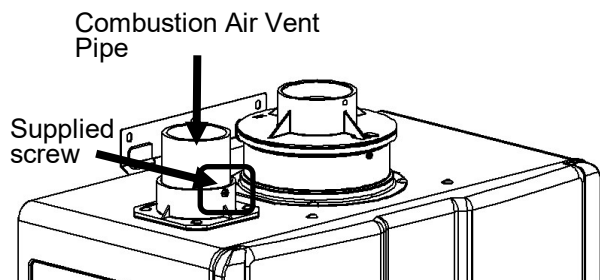

4. Place the vent screen or room air screen inside elbow and secure with the supplied screw. Use the room air screen for environments where room air is dusty.

**NOTE**

- 2 in. vent screen supplied with water heater.
- Room air screen is available as an accessory.

Glue elbow to the combustion air PVC vent pipe per manufacturer's instructions.

Figure 35

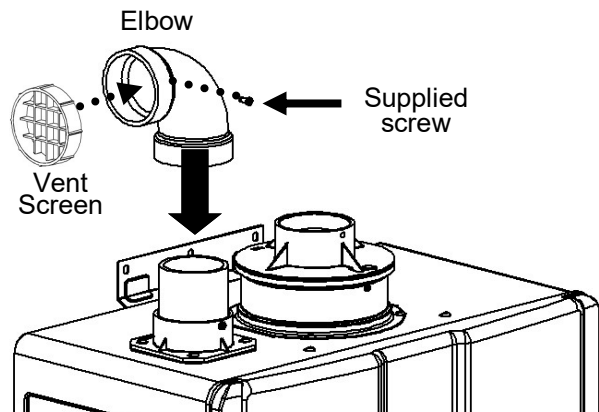

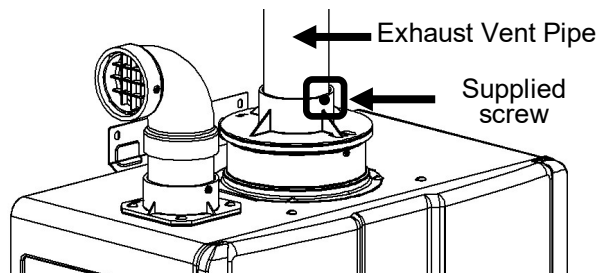

5. Install the exhaust vent pipe. Ensure it is properly seated. Secure the exhaust vent pipe to the exhaust adapter ring with the supplied screw.

Figure 36

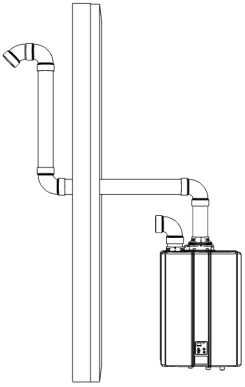
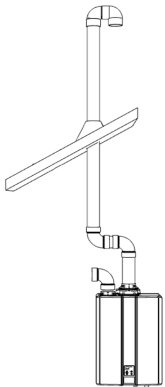
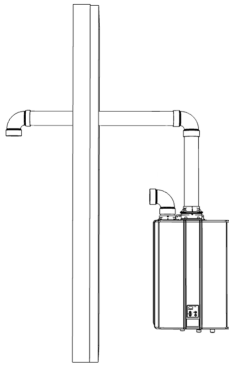
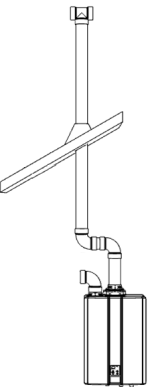
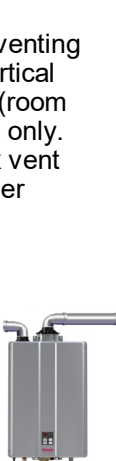

## 2 Non-Direct Vent (Room Air)

### Non-Direct Vent (Room Air) Example Vent Applications

<p>2 in. or 3 in. Schedule 40 PVC/CPVC Snorkel Termination Configuration</p> 	<p>2 in. or 3 in. Schedule 40 PVC/CPVC Standard Upside Down "U" Vertical Termination Configuration</p> 
<p>2 in. or 3 in. Schedule 40 PVC/CPVC Elbow or Tee Side Wall Termination Configuration</p> 	<p>2 in. or 3 in. Schedule 40 PVC/CPVC Tee Vertical Termination Configuration</p> 
<p>Ubbink flexible venting approved for vertical non-direct vent (room air) applications only. Refer to the flex vent manual for further details.</p> <div style="display: flex; align-items: center;">  <div style="margin-left: 20px;"> <p>PP Flex Venting</p>  <p>B-Vent Pipe 4 in. (102 mm)</p> </div> </div>	

Slope horizontal exhaust 1/4 in. per foot towards the water heater.

### Non-Direct Vent (Room Air) Maximum Vent Length

Room Air Maximum Equivalent Length Table			
Vent Sizes	2 in. (51 mm)	3 in. (76 mm)	2 in. (51 mm) Ubbink Flex
Vent Lengths	65 ft (20 m)	150 ft (46 m)	50 ft (15 m)
<ul style="list-style-type: none"> <li>45° elbow is equivalent to 3 ft (1 m)</li> <li>90° elbow is equivalent to 6 ft (2 m)</li> </ul>			

### 3

## Common Vent (Indoor Units Only. Direct Vent and Non-Direct/Room Air Vent)

Common venting allows multiple Rinnai Tankless Water Heaters to share the same vent system. Rinnai water heaters can only be common vented with Schedule 40 PVC/CPVC or with the Rinnai certified common vent system.

Figure 37

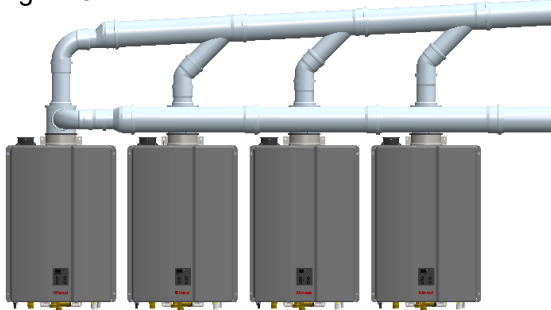

Example: Rinnai Common Venting

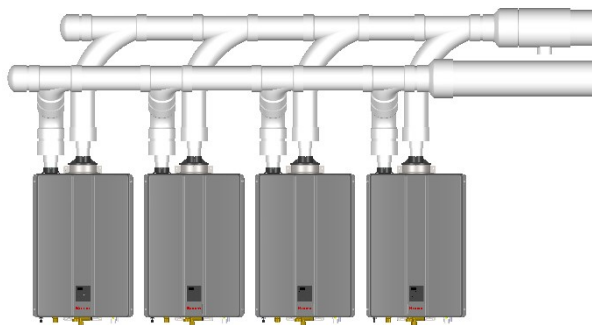

Example: Schedule 40 PVC/CPVC Common Vent

### General Guidelines

When installing Common Vent, follow these guidelines:

- Use only the materials listed in this manual for vent, air intake pipe, and fittings. Failure to comply with this warning could result in property damage, personal injury, or death.
  - When cutting vent components, ensure that the cuts are straight.
  - Chamfer and deburr all edges before installing the components.
  - Vent joints must not leak. Confirm gas tight connections of every vent joint.
  - Before operating the water heater(s), ensure vent system is clean and free of debris.
- Vent system must be supported according to the vent manufacturer's installation instructions.
  - Venting should be as direct as possible with a minimum number of fittings.
  - The common vent system must only be installed by a trained and qualified professional.

### Common Vent Termination Clearances

- Vent termination per ANSI Z223.1/NFPA 54. For clearances not specified in ANSI Z223.1/NFPA 54, clearances are in accordance with local installation codes and the requirements of the gas supplier.

### **WARNING**

- ❌ DO NOT slope the combustion air pipe toward unit. Failure to comply with this warning could result in property damage, personal injury, or death.
- ❌ DO NOT apply PVC/CPVC glues, solvents, or cleaners to the tankless water heater's intake or exhaust gasket connections. Failure to correctly assemble the components according to these instructions may result in property damage, personal injury, or death.
- ❌ DO NOT obstruct combustion air flow or exhaust gas flow in the venting system.
- ❌ DO NOT install the water heater in an area with negative air pressure.
- ❌ DO NOT combine the common vent system with existing vents, chimneys, or vent pipes connected to other water heaters, boilers or appliances.
- ❌ DO NOT common vent different Rinnai models in a single common vent system.
- ❌ DO NOT use cellular core PVC/CPVC, Radel or galvanized materials.
- ❌ DO NOT combine vent components from different manufacturers.

## 5.2.1 Common Vent Maximum Equivalent Vent Lengths

**For the table below:**

- Header is the main vent pipe into which several vents connect
- Vent Length is the distance from the end of the header to the vent termination.
- Maximum vent length starts at the end of the header system.
- Use 10 ft (3 m) as equivalent vent length for 90° elbows.

Figure 38

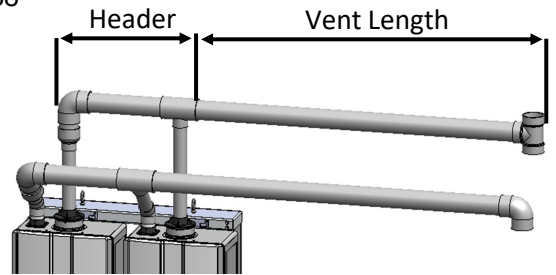

Common Vent Maximum Equivalent Vent Length Rinnai Common Vent System or Schedule 40 PVC/CPVC						
Water Heater Model	# Water Heaters	Max System BTU/HR	HEADER DIAMETER			
			3 in.	4 in.		6 in.
			3 in. Vent Diameter	4 in. Vent Diameter	6 in. Vent Diameter	6 in. Vent Diameter
CU199i (REU-N3237FFC-US)	2	398,000	65 ft	150 ft	150 ft	150 ft
	3	597,000		65 ft		
	4	796,000				
	5	995,000				
	6	1,194,000				
	7	1,393,000		70 ft		
	8	1,592,000				
CU160i (REU-N2530FFC-US)	2	320,000	90 ft	150 ft	150 ft	150 ft
	3	480,000		100 ft		
	4	640,000		65 ft		
	5	800,000				
	6	960,000				
RU130i (REU-N2024FF-US)	2	260,000	90 ft	150 ft	150 ft	150 ft
	3	390,000		100 ft		
	4	520,000		65 ft		
	5	650,000				
	6	780,000				



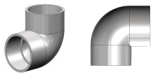
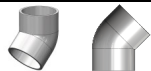

## 5.2.2 Common Vent Terminations

### Various 3 in., 4 in. and 6 in. Schedule 40 PVC/CPVC Terminations

Product Description	Diagram	Horizontal	Vertical	Equivalent Length (ft)
Tee		✓	✓	10
90° Elbow		✓	✓	10
45° Elbow		✓	✓	5

### Rinnai Common Vent Terminations (Ubbink C-Vent)

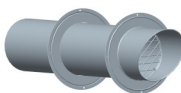
Manufacturer	Phone	Web Site
Ubbink	800-621-9419	<a href="http://www.rinnai.us">www.rinnai.us</a>

Part Number	Product Description	Diagram	Horizontal	Vertical	Equivalent Length (ft)
790096 790095	CVent Roof Termination 6 in. CVent Roof Termination 4in.			✓	5
790125	CVent Roof Termination 3 in.			✓	5
790094 790093 90124	CVent Wall Terminal Kit 6 in. CVent Wall Terminal Kit 6 in. CVent Wall Terminal Kit 6 in.		✓		5
780061 780060	Intake Rain Cap 6 in. Intake Rain Cap 4 in.			✓	N/A
790098 790097	Exhaust Flue Rain Cap 6 in. Exhaust Flue Rain Cap 4 in.			✓	N/A

## 5.2.3 Schedule 40 PVC/ CPVC Common Vent Guidelines

**⚠ WARNING** PVC solvents (primer and glue) can be extremely flammable. Vapors may cause a flash fire or explosion resulting in property damage, personal injury or death.

- Keep solvents away from heat, sparks, flames and all other sources of ignition.
- Do not solder, cut or weld until all vapors have dissipated.
- PVC solvents are heavier than air causing them to settle at low points of the system.
- Before using PVC solvent
  - Disconnect power to the water heater.
  - Remove the front cover of the water heater.
  - Ensure areas around the water heater and PVC venting are all well ventilated.
  - Allow all vapors to dissipate before applying power to the system or introducing any other source of ignition.

When installing PVC/CPVC Common Vent, follow these guidelines:

- Avoid sharp bends or tees in the vent system. These vent components create additional restrictions that could reduce performance of the water heaters.
- PVC combustion air and exhaust should terminate with elbow or tee pointing down. This will stop unwanted moisture from entering the vent system.
- Fire rated penetrations shall be firestopped. Contact your vent supplier or local firestop manufacturer for appropriate firestop methods.
- Examine all vent components for damage prior to installation.
- PVC/CPVC vent systems must be free to expand and contract. Refer to the vent manufacturer's installation instructions for appropriate support methods.
- PVC/CPVC venting must include unrestricted vent movement through walls, ceilings, and roof penetrations.
- Use only PVC/CPVC primer and cement approved for use by the vent manufacturer.

- Refer to vent manufacturer's installation instructions for proper joint assembly procedures and products.
- PVC/CPVC common venting should include a condensate drain and trap between the header and vent length. Condensate trap must include a loop that can hold 6 in. (15 cm) of water. See "PVC/CPVC Common Vent Installation" illustration on this page.

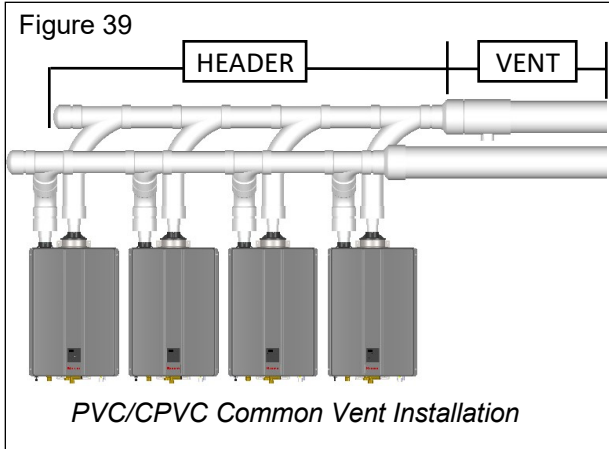

### DO NOT

- ❌ DO NOT mix vent pipe, fittings or joining methods from different vent manufacturers.
- ❌ DO NOT attempt to repair damaged vent. Damaged vent components must be replaced.
- ❌ DO NOT use short radius elbows in the common vent system.

ACCEPTABLE	ACCEPTABLE
90° Elbows, Long Sweep	90° Elbows, Short Sweep

NOT ACCEPTABLE
90° Elbows, Close Turn

# 6. System Plumbing

## Topics in this section

- Pressure Relief Valve Requirements
- Temperature - PRV Requirements
- Connect the Water Heater to the Water Supply
- Typical Installations
- Piping Diagram for Basic Installations
- Piping Diagram for Multiple Unit Installations

## 6.1 PRV Requirements

An approved pressure relief valve (preinstalled) is required by the *American National Standard (ANSI Z21.10.3)* for all water heating systems and shall be accessible for servicing.

### **DO NOT**

- Do not plug the relief valve and do not install any reducing fittings or other restrictions in the relief line. The relief line should allow for complete drainage of the valve and the line.
- Do not place any other type valve or shutoff device between the relief valve and the water heater.

### **WARNING**

Water discharged from the pressure relief valve could cause severe burns instantly or death from scalds.

### **MUST DO**

- The relief valve must comply with the standard for *Relief Valves and Automatic Gas Shutoff Devices for Hot Water Supply Systems ANSI Z21.22* and /or the standard *Temperature, Pressure, Temperature and Pressure Relief Valves and Vacuum Relief Valves, CAN1-4.4*.
- The pressure relief valve must be rated up to 150 psi and to at least the maximum Btu/hr of the appliance.
- The discharge from the pressure relief valve should be piped to the ground or into a drain system per local codes.
- The pressure relief valve must be manually operated once a year to check for correct operation.

- The relief valve is installed near the tankless hot water outlet.

### **INFORMATION**

If a relief valve discharges periodically, this may be due to thermal expansion in a closed water supply system. Contact the water supplier or local plumbing inspector on how to correct this situation. Do not plug the relief valve.

## 6.2 Temperature - PRV Requirements

Install the Temperature-Pressure Relief (T&P) Valve according to these instructions.

The tank portion of this system is provided with a combination T&P relief valve. For safe operation of the water heater, the relief valve(s) must not be removed from its designated point of installation or plugged.

An approved T&P relief valve is required by the *American National Standard (ANSI Z21.10.3)* for all water heating systems, and shall be accessible for servicing.

### **DO NOT**

- Do not plug the T&P relief valve and do not install any reducing fittings or other restrictions in the relief line. The relief line should allow for complete drainage of the T&P relief valve and the line.
- Do not place any other type valve or shut off device between the relief valve and the water heater.
- Do not pipe T&P relief valve, pressure relief valve, and/or condensate drain together into a common pipe.

### **MUST DO**

- The T&P valve must comply with the standard for *Relief Valves and Automatic Gas Shutoff Devices for Hot Water Supply Systems ANSI Z21.22* and /or the standard *Temperature, Pressure, Temperature and Pressure Relief Valves and Vacuum Relief Valves, CAN1-4.4*.

- The T&P relief valve must be rated up to 150 psi and to at least the maximum Btu/hr of the appliance.
- The discharge from the T&P relief valve should be piped to the ground or into a drain system to prevent exposure or possible burn hazards to humans or other plant or animal life. Follow local codes. Water discharged from the relief valve could cause severe burns instantly, scalds, or death.
- The T&P relief valve must be manually operated once a year to check for correct operation.

## 6.3 Connect the Water Heater to the Water Supply

Water connections to the Commercial Hybrid System should follow all state and local plumbing codes.

If this is a standard installation, refer to section "6.5 Piping Diagram for Basic Installations."

1. Use of this layout should provide a trouble-free installation for the life of the water heater. Before making the plumbing connections, locate the **COLD** water inlet and the **HOT** water outlet.
  - The **COLD** water inlet is a 1-1/2 in. MNPT fitting on the lower portion of the tank below the tankless unit.
  - The **HOT** water outlet is a 1-1/2 in. MNPT fitting located at the top of the tank. Install a shut-off valve close to the water heater in the cold water line. It is recommended that unions be installed in the cold and hot water lines so that the water heater can be easily disconnected, if servicing is required.
2. When assembling the hot and cold piping, use a good food grade pipe joint compound, and ensure all fittings are tight. It is imperative that open flame is not applied to the inlet and outlet fittings, as heat will damage or destroy the plastic lined fittings. **This will result in premature failure of the fittings, which is not covered by the warranty.**

## 6.3.1 Filling the System

**DO NOT OPERATE THIS WATER HEATER UNLESS IT IS COMPLETELY FULL OF WATER.** To prevent damage to the water heater, all air must be relieved from the system and a hot water fixture must be flowing water before the water heater is plugged in and turned on. To ensure safe and effective operation of the water heater, use the following filling procedure. To fill the water heater:

1. Ensure the drain valve located at the bottom of the tank is closed.
2. Open the nearest hot water fixture in the plumbing system.
3. Open the cold water supply valve to the water heater.
4. Keep the hot water fixture open until the tank is filled and constant flow is obtained at the fixture.
5. Check water heater connections and plumbing system for damage or leaks. Repair if needed.

### NOTICE

**DO NOT OPERATE THIS WATER HEATER UNLESS IT IS COMPLETELY FULL OF WATER.**

## 6.3.2 Condensate

Condensate can form in the vent of high efficiency direct vent appliances. Without proper drainage, condensate will damage the heat exchanger. Refer to Rinnai Tankless Water Heater Installation and Operation Manual for condensate guidelines.

To prevent condensate damage, follow these instructions.

### **DO NOT**

- Do not connect the condensate drain pipe directly to the rain sewer.
- Do not connect the condensate drain line with an air conditioning evaporator coil drain.
- Do not pipe condensate drain, temperature-pressure relief valve, and/or pressure relief valve together into a common pipe.
- Do not install an external condensate trap. The tankless water heater has an integrated condensate trap.

### **MUST DO**

- Use only venting that is approved and identified as acceptable for your particular model.

- Slope the venting toward the appliance according to the vent manufacturer's installation instructions.
- All condensate must drain and be disposed of according to local codes.
- Use only corrosion resistant materials for the condensate drain lines such as PVC pipe or plastic hose.
- The condensate drain pipe (along its entire length) must be at least the same diameter as the drain line, (1/2 inch NPT).
- The end of the condensate drain pipe should be open to the atmosphere. The end should not be under water or other substances.
- To minimize freezing of the condensate, run the condensate drain line through an interior wall or between insulation and an interior wall.
- Ensure that condensate drain, PRV, and T&P relief valve are piped separately to their own dedicated drain lines.
- Dispose of condensate per local codes.

**INFORMATION**

- Water heaters have an integrated condensate collector.
- The condensate drain pipe should be as short as possible and have a downward pitch.
- If the condensate drain gets blocked, a diagnostic code will display on the controller. If this occurs, the condensate drain must be cleaned.
- The condensate trap will automatically prime (self-prime) during operation of the unit as condensate forms. Condensate draining from the unit indicates that the trap is full and that there is no blockage in the condensate drain. It is not necessary to add water to the condensate trap.
- A condensate neutralizer kit (Part Number: [804000074](#)) is available from Rinnai. The kit allows condensate to flow through neutralizing media that raises the pH of the condensate to a level that will help prevent corrosion of the drain and public sewer system.

 **DO NOT**

- DO NOT connect the condensate drain line with an air conditioning evaporator coil drain.
- Water heaters have an integrated condensate trap. DO NOT install an external condensate trap.

 **EXTERNAL TRAP NOT REQUIRED**

A condensate line must be installed to the 1/2 in. PVC elbow located at the left side of the lower enclosure.

Condensate line must pitch toward the drain.

Air gap must be installed on the condensate line to enable the condensate to drain.

- The end of the condensate drain pipe should be open to the atmosphere. The end should not be under water or other substances.

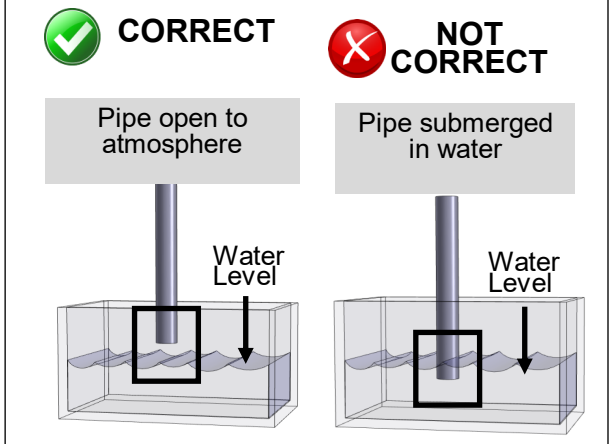
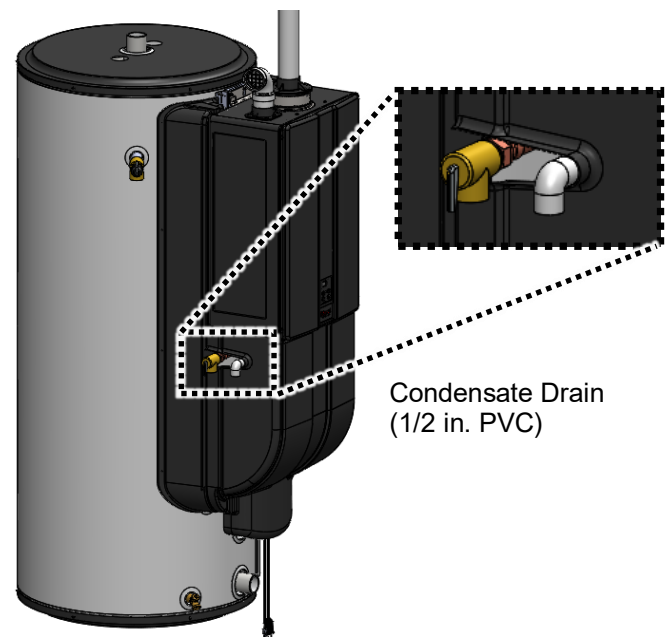

Figure 40



# 6.4 Typical Installations

<b>A</b>	Hot Water Outlet	*
<b>B</b>	Hot Water Outlet Valve	*
<b>C</b>	Cold and Hot Unions	*
<b>D</b>	Temperature-Pressure Relief Valve	
<b>E</b>	Operation Unit / Temperature Control	
<b>F</b>	Temperature-Pressure Relief Valve Discharge Pipe (do not cap, plug, or reduce)	*
<b>G</b>	Pressure Relief Valve Discharge Pipe (do not cap, plug, or re-	*
<b>H</b>	Condensate Discharge Pipe (Must include air gap)	*
<b>I</b>	Drain Pan	*
<b>J</b>	Vent pipe (PVC Room Air shown for illustration purposes, see venting section for other options)	*
<b>K</b>	Gas Control Valve	*
<b>L</b>	Gas Union	*
<b>M</b>	Drip Leg (Sediment Trap)	*
<b>N</b>	Cold Water Supply Valve	*
<b>O</b>	Cold Water Supply	*
<b>P</b>	Thermal Expansion Tank	*
<b>Q</b>	Non-Tempered Supply Line	*
<b>R</b>	Thermostatic Mixing Valve	*
<b>S</b>	Purge Line	*
<b>T</b>	Check Valve	*

\* Field Supplied

Figure 41

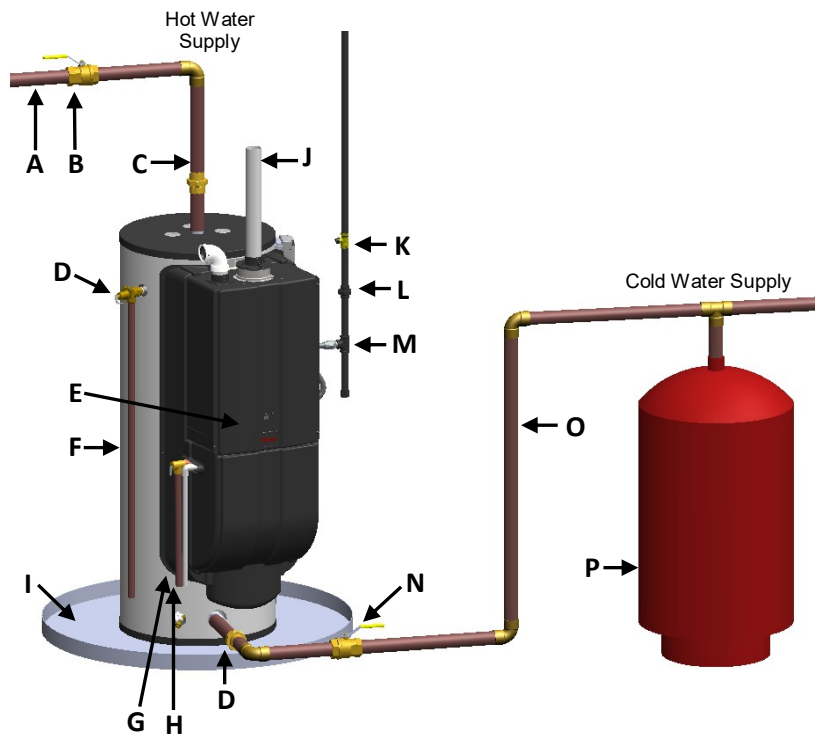

## Mixing Valve Installation

Figure 42

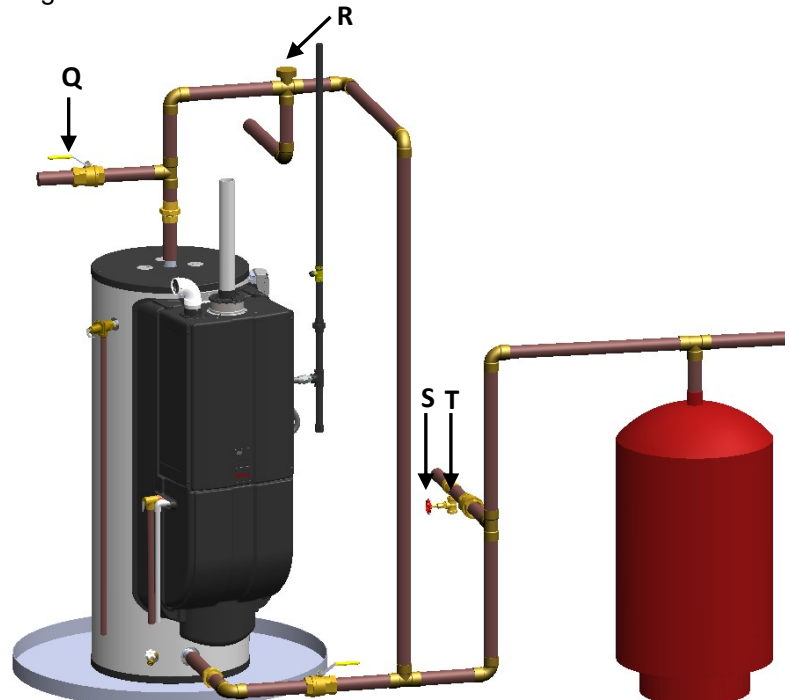

# 6.5 Piping Diagram for Basic Installations

Figure 43

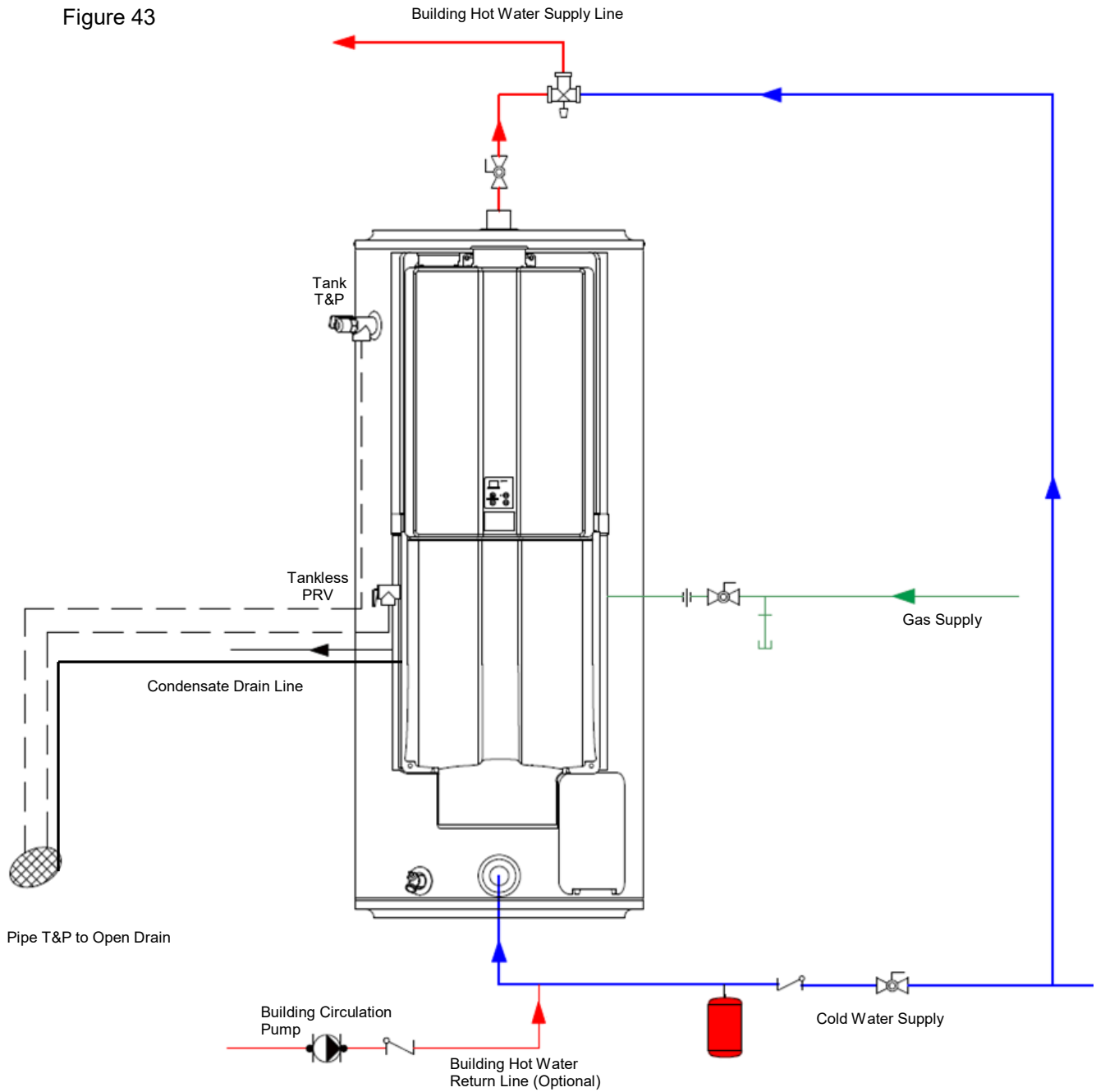

Commercial Hybrid

Single Unit Circulation

**Note:**

Installation must conform to applicable code and all requirements listed in the installation manual. Balancing valves, equivalent piping, pressure gauges, and temperature gauges are to be used as necessary to ensure proper flow between units.

Condensate piping shall be CPVC or PVC material and shall not be smaller than the drain connection on the appliance.

Components of condensate drainage shall be CPVC or PVC material. All components shall be selected for the pressure and temperature rating of the installation.

Where the drain pipes from more than one unit are manifolded together for condensate drainage, the pipe or tubing shall be sized in accordance with an approved method as dictated by local codes.

Condensate must be disposed of according to local codes.

## 6.6 Piping Diagram for Multiple Unit Installations

Figure 44

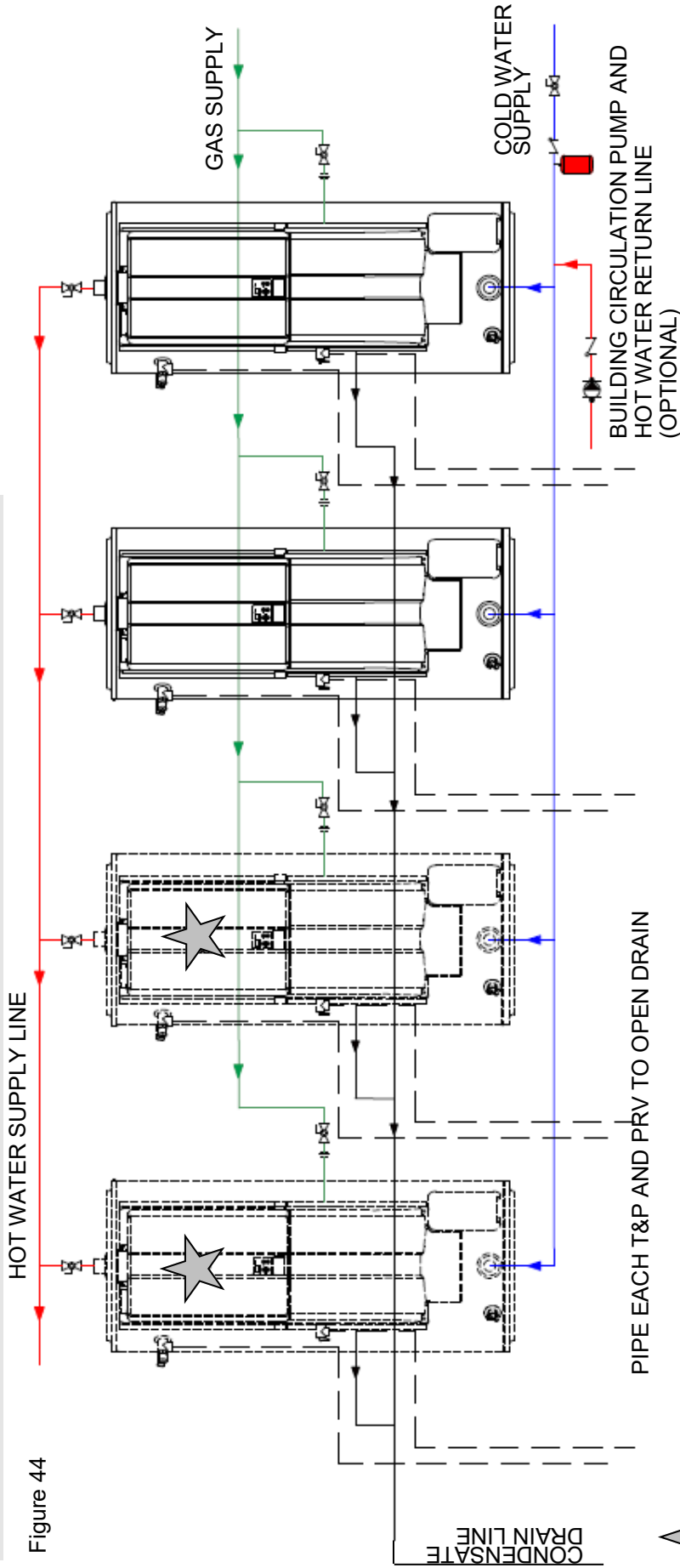

Additional units can be installed as illustrated.

### Notes:

- Installation must conform to applicable code and all requirements listed in the installation manual. Balancing valves, equivalent piping, pressure gages, and temperature gages are to be used as necessary to ensure proper flow between units.
- Condensate piping shall be CPVC or PVC material and shall not be smaller than the drain connection on the appliance.
- Components of the condensate drainage shall be CPVC or PVC material. All components shall be selected for the pressure and temperature rating of the installation.
- Where the drain pipes from more than one unit are manifolded together for condensate drainage, the pipe or tubing shall be sized in accordance with an approved method as dictated by local codes.
- Condensate must be disposed of according to local codes.

# 7. Gas and Power Supply

## Topics in this section

- Connect the Gas Supply
- Connect Electricity
- Pump Controller

### **WARNING**

- A licensed professional must install the gas supply.
- Turn off 120V power supply.
- Turn off the gas.
- Gas is flammable. Do not smoke or provide other ignition sources while working with gas.
- Do not turn on the water heater or gas until all fumes are gone.

Figure 45

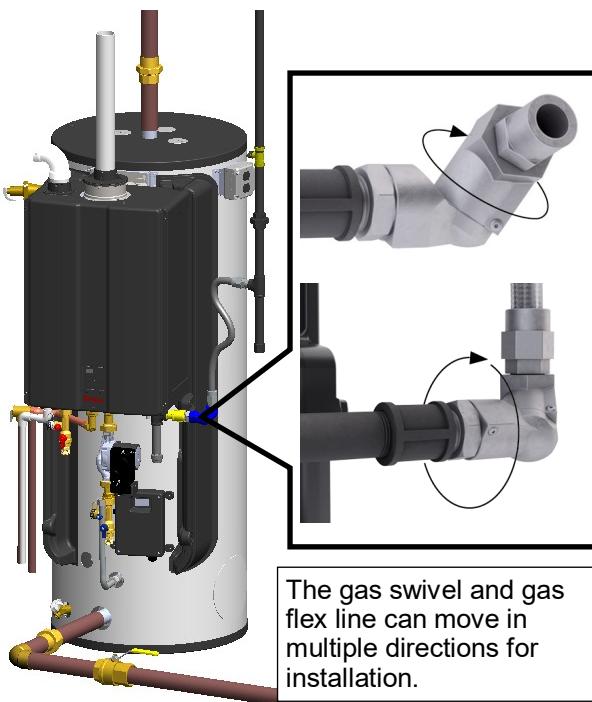

## 7.1 Connect the Gas Supply

To connect the gas supply, follow the instructions below:

1. Install a manual gas control valve in the gas supply line to the water heater. A union can be used on the connection above the shut off valve for the future servicing or disconnection of the water heater (Figure 45 on the following page).
2. Check the type of gas and gas supply pressure before connecting the water heater. If the water heater is not of the gas type that the building is supplied with, DO NOT connect the water heater. Contact the dealer for the proper water heater to match the gas type.
3. Check the gas supply pressure immediately upstream at a location provided by the gas company. Supplied gas pressure must be within the limits shown in the Section “3.2 Specifications” with all gas appliances operating.

Figure 46

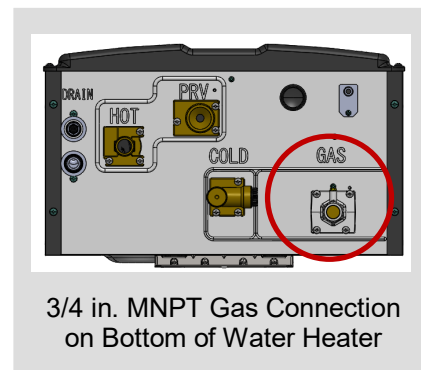

5. Before placing the appliance in operation, all joints including the heater must be checked for gas tightness by means of soap, gas leak detector solution, or an equivalent nonflammable solution, as applicable. (Since some leak test solutions, including soap and water, may cause corrosion or stress cracking, the piping shall be rinsed with water after testing, unless it has been determined that the leak test solution is non-corrosive.)
6. Use approved connectors to connect the water heater to the gas line. Purge the gas line of any debris before connection to the water heater.
7. Any compound used on the threaded joint of the gas piping must be chemically compatible and mechanically suitable to be used in liquified petroleum gas (LPG/Propane) applications.
8. The gas supply line shall be gas tight, sized, and so installed as to provide a supply of gas sufficient to meet the maximum demand of the heater and all other gas consuming appliances at the location without loss of pressure. If in doubt about the size of the gas line, refer to the tankless water heater installation and operation manual.
9. Perform a leak and pressure test prior to operating the water heater. If a leak is detected, do not operate the water heater until the leak is repaired.

Figure 47

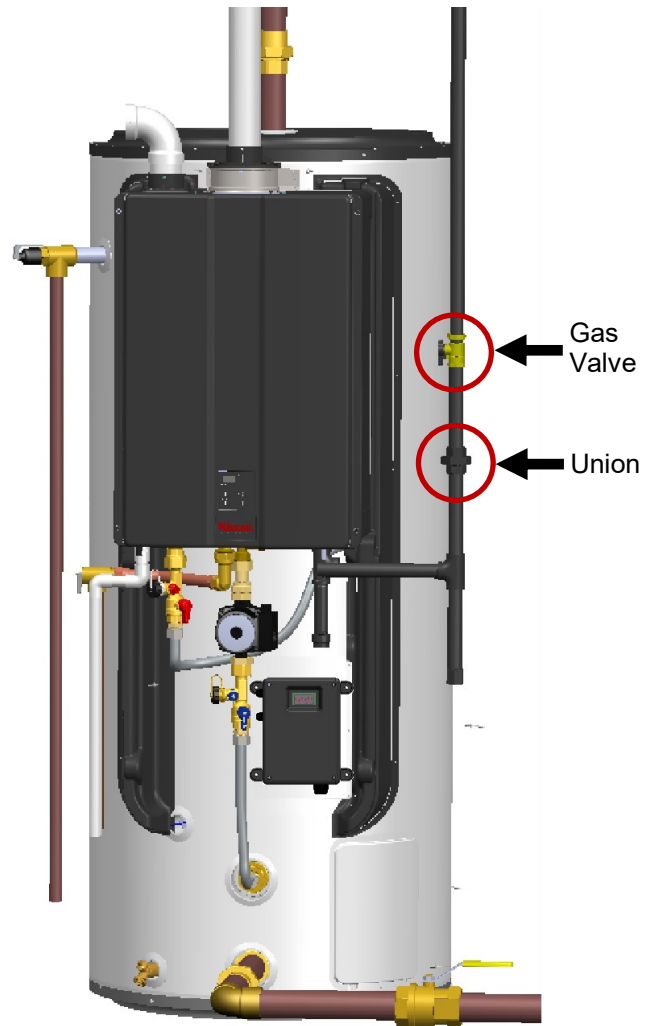

## 7.1.1 Gas Flare Adapter

Figure 48

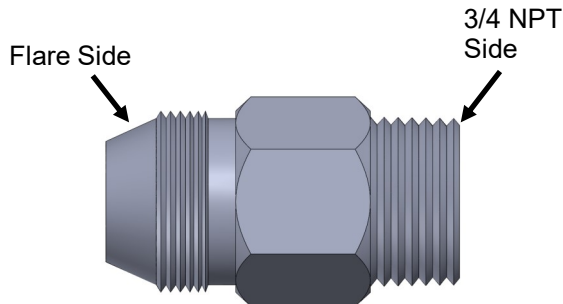

1. Remove Gas Flare Adapter from the end of the Gas Flex Hose Assembly.
2. Apply a pipe sealant approved for gas to the 3/4 NPT side of the Gas Flare Adapter.

**NOTE**  
DO NOT apply sealant to the parallel threads on the flare side of the Gas Flare Adapter.

3. Thread the 3/4 NPT side of the Gas Flare Adapter into the field connection gas supply (Figure 49).

Figure 49

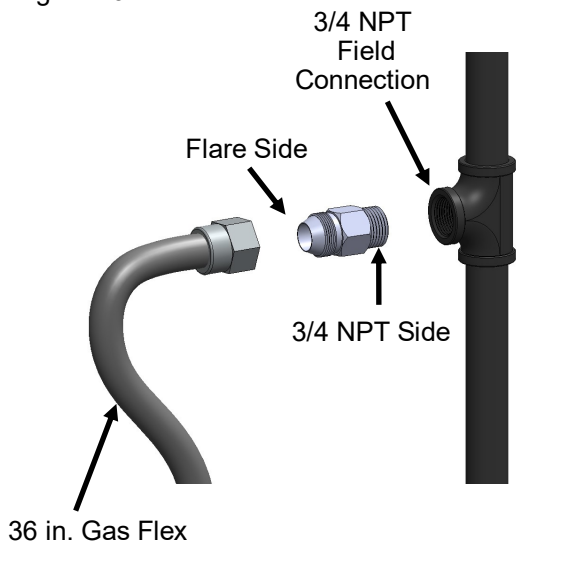

4. Thread the flare side of the 36 in. Gas Flex into the flare side of the Gas Flare Adapter (Figure 50).

Figure 50

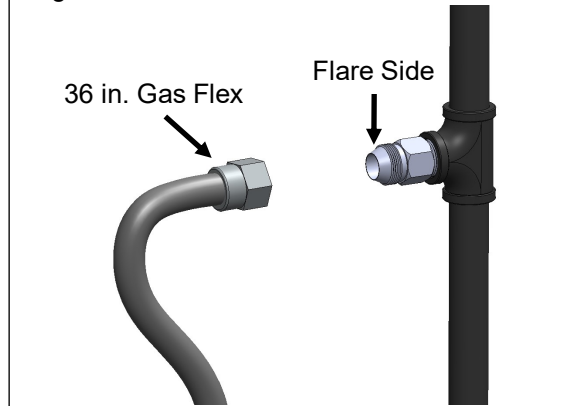

5. Use a backer wrench to tighten all connections to the recommended torque value of 62 lbs-ft.

Figure 51

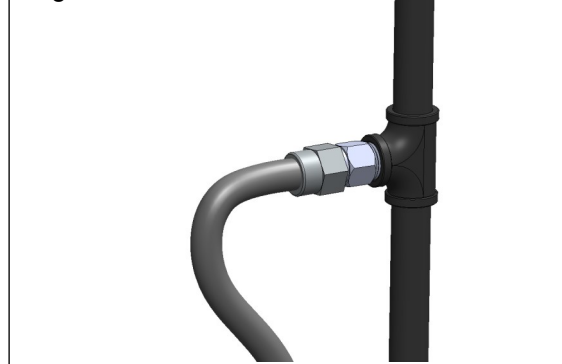

6. Leak test ALL gas fittings and assembly using a leak test solution, soap and water, or an equivalent nonflammable solution.
7. If leak is identified at the flex connection, gradually tighten fitting until leak stops.

DO NOT connect gas flex directly to pipe threads of gas supply pipe or appliance. Install Gas Flex using only the Gas Flare Adapter provided.

## 7.2 Connect Electricity

### **⚠ WARNING**

- Do not use an extension cord or adapter plug with this appliance.
- The water heater must be electrically grounded in accordance with local codes and ordinances or, in the absence of local codes, in accordance with the National Electrical Code, ANSI/NFPA No. 70.
- The water heater is equipped with a three-prong (grounding) plug for your protection against shock hazard and should be plugged directly into a properly grounded three-prong receptacle. Do not cut or remove the grounding terminal from this plug. This appliance includes an integrated junction box for hard wire or three-prong plug.

### 7.2.1 Guidelines

When connecting the power supply, follow these guidelines:

- Do not rely on the gas or water piping to ground the water heater. Ground locations are provided inside the water heater and inside the provided junction box.
- The water heater requires 120 VAC, 60 Hz power from a properly grounded circuit.
- When using the 6 ft (1.8 m) power cord (included with controller), plug it into the provided 3 prong 120 VAC, 60 Hz properly grounded outlet or hard wire to the integrated junction box.
- The Tankless Water Heater wiring diagram is located on the inside of the water heater front cover. The controller wiring diagram is located on the inside front cover of the controller.

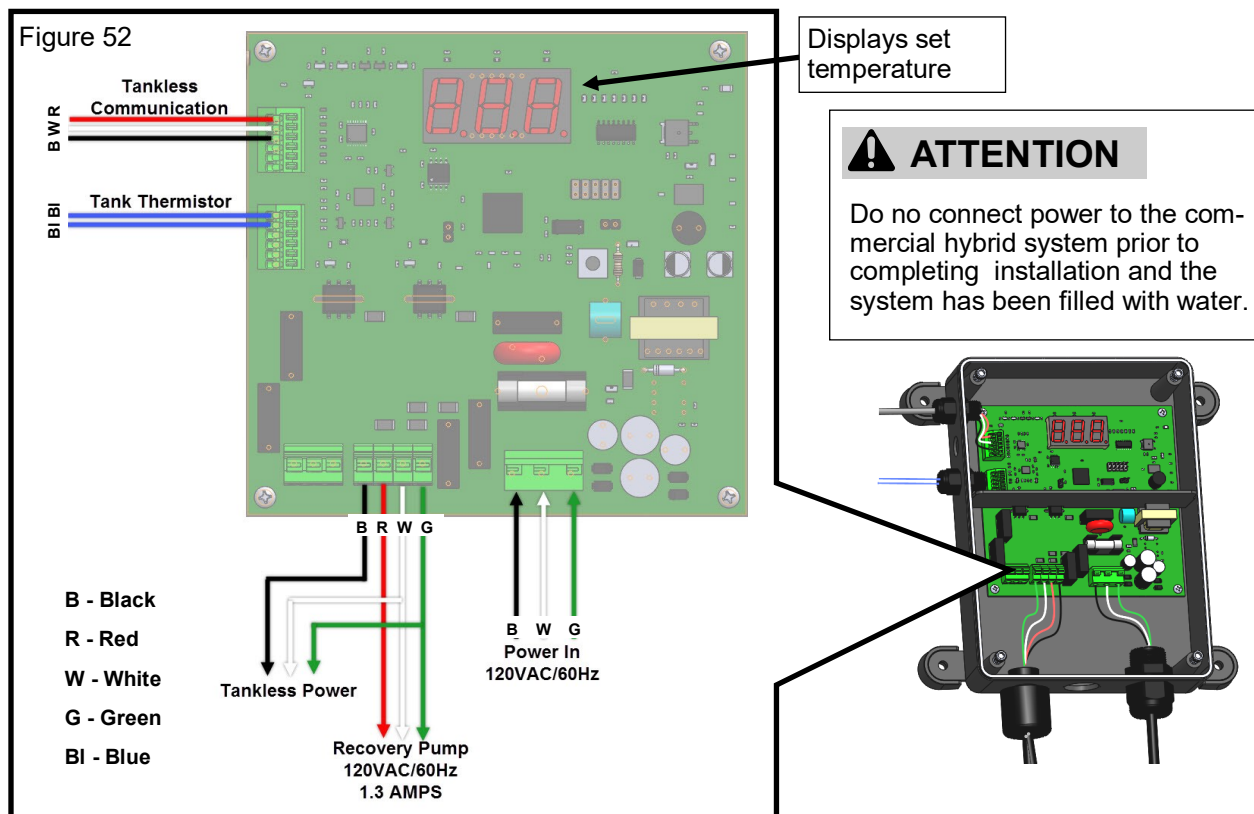

## 7.2.2 Instructions

1. Locate the electric conduit on the side of the water heater (Figure 53).

Figure 53

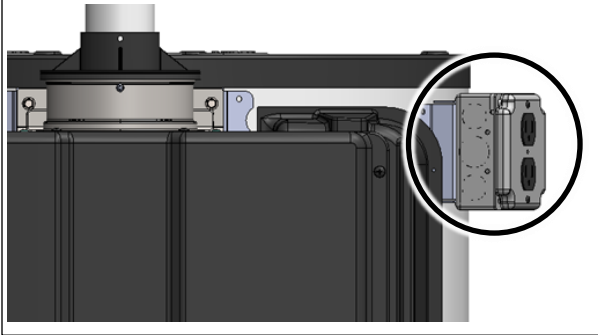

2. Remove the two screws around the outlet cover. Remove the outlet cover and prewired outlet (Figure 54).

Figure 54

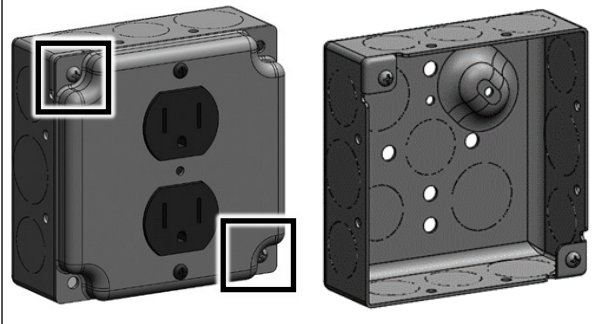

3. Remove the desired knockout along the perimeter of the electric box for conduit installation (Figure 55).

Figure 55

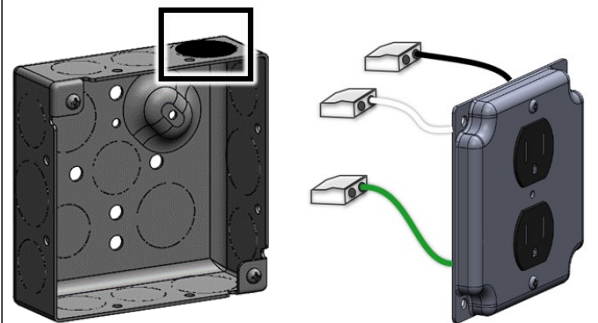

4. Install conduit into the knockout opening and pull the green, white and black wires into the box.
5. Strip the green, white, and black field supplied wires 1/2 in. Make sure the conductors are completely bare (Figure 56).

Figure 56

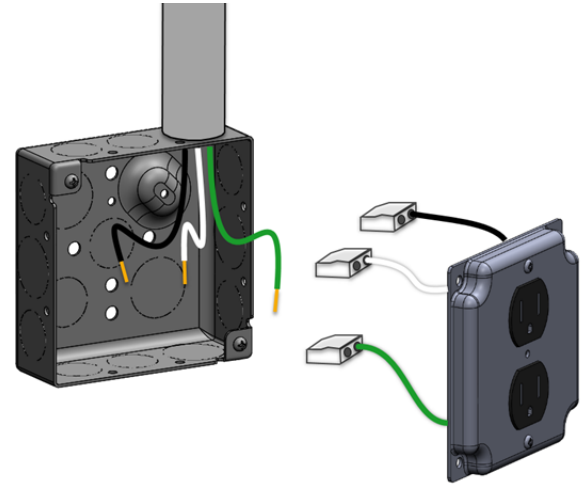

6. Match the wire colors, then grip the wire firmly and push the conductor into open port of the push in connector (Figure 57).

**NOTE**

Use only one conductor per port. Verify conductor is fully inserted to the back of the connector.

Figure 57

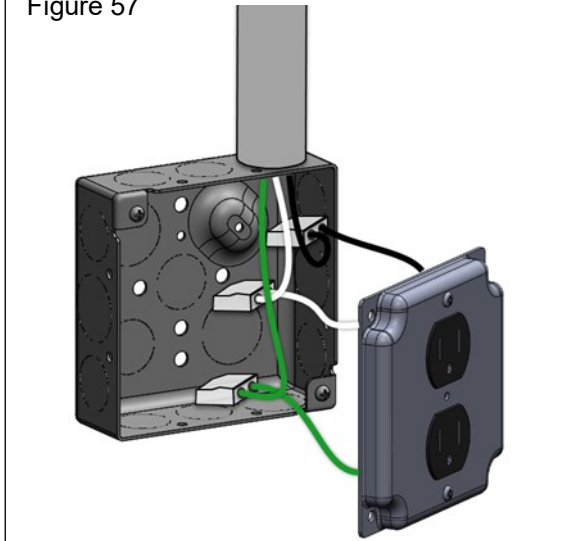

## 7.3 Pump Controller

The system controller maintains communication between the tank and tankless via the tankless communication cable to effectively control the tank temperature based on the selected temperature on the tankless unit.

The system controller will energize (120V) the pump when the tank temperature drops. When the tank temperature returns to the selected set temperature, the system controller will de-energize the pump and remain in standby until the tank temperature drops again.



### ATTENTION

When power is supplied, the system controller will maintain pump operation. If system is not in use for an extended period of time, disconnect power from the system.

### 7.3.1 Controller Diagnostics

Figure 58

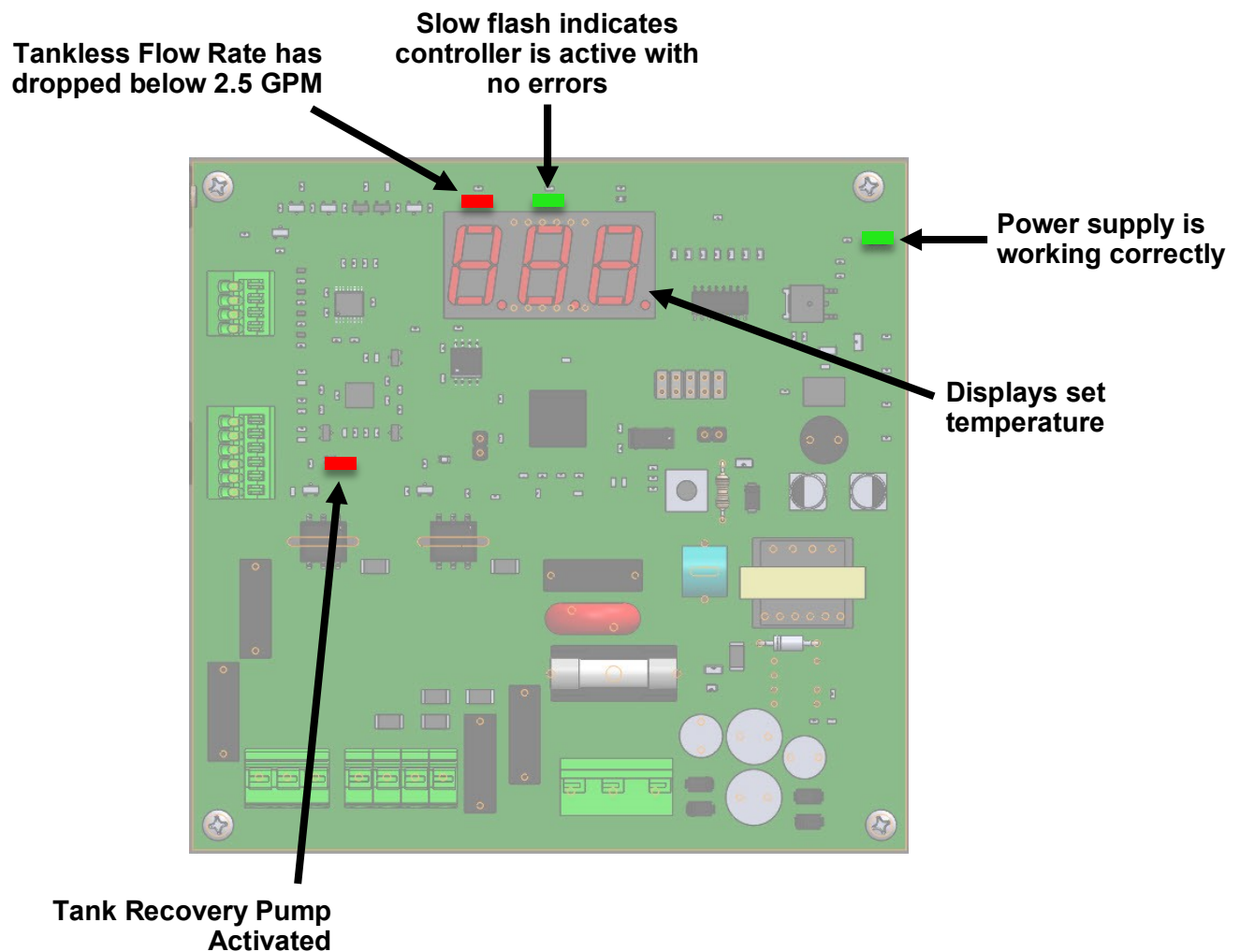

# 8. Post-Installation Checklist

- The water heater is not subject to corrosive compounds in the air.
- The water supply does not contain chemicals or exceed total hardness that will damage the heat exchanger.
- Clearances from the water heater unit are met.
- Clearances from the vent termination / air intake are met.
- Ensure you have used the correct venting products for the model installed and that you have completely followed the venting manufacturer's installation instructions and these installation instructions.
- Verify that the vent system does not exceed the maximum length for the number of elbows used.
- Purge the water line of all debris and air by closing the hot isolation valve and opening the cold isolation valve and its drain. **Debris will damage the water heater.** Use a bucket or hose if necessary.
- Ensure that hot and cold water lines are not crossed to the unit and are leak free.
- A manual gas control valve has been placed in the gas line to the water heater.
- Ensure that a pressure relief valve is installed with a rating that exceeds the BTU input of the water heater model. Refer to the rating plate on the side of the water heater for BTU input.
- Clean the inlet water filter by closing the cold and hot water inlet isolation (shut-off) valves. Put a bucket under the filter at the bottom of the water heater to catch any water that is contained inside the unit. Unscrew the water filter. Rinse the filter to remove any debris. Install the filter and open the isolation valves.
- Check the gas lines and connections for leaks.
- Confirm that the gas inlet pressure is within limits.
- Confirm that the water heater is rated for the gas type supplied.
- Confirm that the electricity is supplied from a 120 VAC, 60 Hz power source, is in a properly grounded circuit, and turned on.
- Verify the temperature controller is functioning properly.
- Confirm parameter settings are set appropriately for the altitude.
- Verify the system is functioning correctly by connecting your manometer to the gas pressure test port on the water heater. Operate all gas appliances in the home or facility at high fire. The inlet gas pressure at the water heater must not drop below that listed on the rating plate.
- DO NOT** introduce toxic chemicals such as those used for boiler water treatment to the potable water used for space heating.
- If the water heater is not needed for immediate use, then drain the water from the heat exchanger.
- Install the front panel.
- Explain to the customer the importance of not blocking the vent termination or air intake.
- Explain to the customer the operation of the water heater, safety guidelines, maintenance, and warranty.
- The installation must conform with local codes or, in the absence of local codes, with the *National Fuel Gas Code, ANSI Z223.1/ NFPA 54*, or the *Natural Gas and Propane Installation Code, CSA B149.1*.
- Leave this manual and the Rinnai Tankless Water Heater manual taped to the water heater, or give both manuals directly to the consumer.**

# 9. Maintenance

## Topics in this section

- Replacement Parts
- Service/Maintenance Log

## Anodes

The storage tank is equipped with two magnesium anodes designed to extend the life of the storage tank. Slowly consumed over time, the anode protects the glass-lined tank from corrosion. It is strongly recommended to inspect the anodes every two (2) years. If more than half of the anodes has been consumed, they should be replaced. Instructions on how to change the anodes can be obtained from the manufacturer.

The longevity of the storage tank can be reduced when a water softener is introduced to fight hard water. Sodium salts added by a softener can make the water extremely conductive; therefore, the anodes are consumed at a faster rate. In such conditions, the anodes should be inspected on a yearly basis.

In certain conditions, the anodes may react with the water, producing discolored or smelly water. The most common complaint is hot water that smells like rotten eggs. This is the result of the reaction between the anode and hydrogen sulphide gas dissolved in the water, which is common in well systems. This issue can usually be eliminated or reduced by changing the magnesium anodes to aluminum anodes and by chlorinating the storage tank and plumbing system. If the problem continues, special filtration equipment may be required. Under no circumstances are the anodes to be removed from the water heater on a permanent basis.

**Removal of the anodes will lead to premature failure of the water heater and will void the warranty.**

Figure 59

### Anode Replacement Procedure

1. Remove plastic caps.
2. With 1-1/8 in. socket wrench, remove the anode.

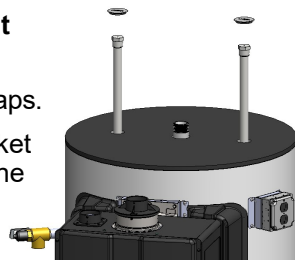

## Storage Tank

Drain a pail of water through the drain valve at least once a year. This will remove excess sediment from the bottom of the tank. This sediment, if allowed to accumulate, will reduce the efficiency and the life of the tank.

## Draining the Storage Tank

To completely drain the storage tank:

1. Turn the power "OFF" to the system by unplugging power to the system. (The system will not be fully shut down by simply pressing the power button on the controller)
2. Close the cold water supply manual shut-off valve.
3. Connect one end of a garden hose to the storage tank drain valve and put the other end next to a free-flowing drain.
4. Open the drain valve by turning the knob counter clockwise 
5. Open a hot water faucet to allow air into the system.

Figure 60



# 9.1 Replacement Parts

## 9.1.1 119 Gallon Models

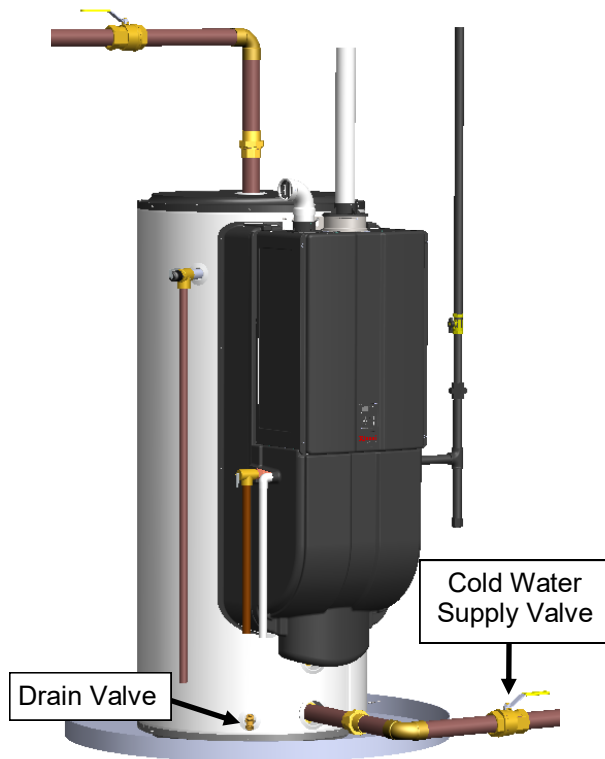
ITEM NO.	PART NUMBER	DESCRIPTION
1	CU199iN/CU199iP CU160iN/CU160iP	RINNAI SENSEI TANKLESS
2	109000741	LEFT COVER
3	109000740	RIGHT COVER
4	109000732	FRONT COVER
5	104000297	PUMP UNION KIT
6	107000387	CONDENSATE PIPE (PVC)
7	107000308	1-1/2 IN DIELECTRIC NIPPLE
8	107000309	1 IN DIELECTRIC NIPPLE
9	107000472	FVMX-6LS 1 IN MALE T&P 500KBTU/HR
10	107000257	CHECK VALVE
11	107000375	PRV PIPE (45 DEG)
12	105000322	SENSEI CONTROLLER ASSEMBLY
13	105000225	THERMISTOR, 3/4MNPT, 10K OHM
14	107000452	PRV CONNECTION ASSEMBLY
15	107000260	HEX NIPPLE, 3.4 IN
16	107000458	PUMP
17	107000311	TANK CLEANOUT FLANGE GASKET
18	107000312	HAND HOLE CLEANOUT COVER
19	109000633	CLEANOUT BOLTS 5/16IN-18 X 1 IN
20	107000255	FLEX, LENGTH 12 IN, 3/4 NPSH X 3/4 NPSH
21	107000401	TANK, 119 GALLON W/BRACKETS
22	107000398	TUBE, 43.95 X 3/4 NPSH X 3/4 NPSH
23	107000185	90° FEM X MALE ELBOW, 3/4IN
24	107000284	HOT, COLD, PRV VALVE KIT
25	107000314	ANODE ROD, MAGNESIUM
26	107000315	BRASS DRAIN VALVE 3/4 X 2-3/4
27	105000337	ELECTRICAL ASSEMBLY
28	106000165	DIRT LEG 3/4 IN
29	106000164	GAS SWIVEL
30	106000166	GAS FLEX HOSE

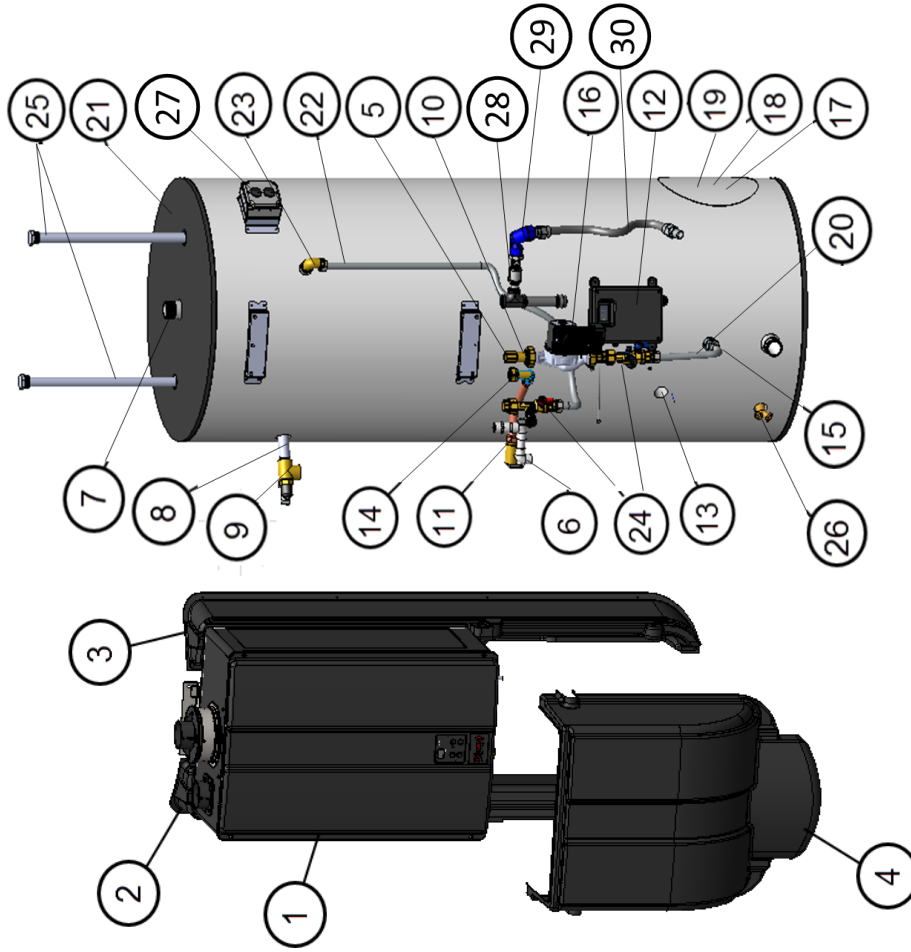

## 9.1.2 80 Gallon Models

ITEM NO.	PART NUMBER	DESCRIPTION
1	CU199iN/CU199iP CU160iN/CU160iP RU130iN/RU130iP	RINNAI SENSEI TANKLESS
2	109000741	LEFT COVER
3	109000740	RIGHT COVER
4	109000732	FRONT COVER
5	104000297	PUMP UNION KIT
6	107000387	CONDENSATE PIPE (PVC)
7	107000308	1-1/2 IN DIELECTRIC NIPPLE
8	107000309	1 IN DIELECTRIC NIPPLE
9	107000472	FVMX-6LS 1 IN MALE T&P 500KBTU/HR
10	107000257	CHECK VALVE
11	107000375	PRV PIPE (45 DEG)
12	105000322	SENSEI CONTROLLER ASSEMBLY
13	105000225	THERMISTOR, 3/4MNPT, 10K OHM
14	107000452	PRV CONNECTION ASSEMBLY
15	107000260	HEX NIPPLE, 3,4 IN
16	107000458	PUMP
17	107000311	TANK CLEANOUT FLANGE GASKET
18	107000312	HAND HOLE CLEANOUT COVER
19	109000633	CLEANOUT BOLTS 5/16IN-18 X 1 IN
20	107000255	FLEX, LENGTH 12 IN, 3/4 NPSH X 3/4 NPSH
21	107000253	TANK, 80 GALLON W/BRACKETS
22	107000398	TUBE, 43.95 X 3/4 NPSH X 3/4 NPSH
23	107000185	90° FEM X MALE ELBOW, 3/4IN
24	107000284	HOT, COLD, PRV VALVE KIT
25	107000314	ANODE ROD, MAGNESIUM
26	107000315	BRASS DRAIN VALVE 3/4 X 2-3/4
27	105000337	ELECTRICAL ASSEMBLY
28	106000165	DIRT LEG 3/4 IN
29	106000164	GAS SWIVEL
30	106000166	GAS FLEX HOSE

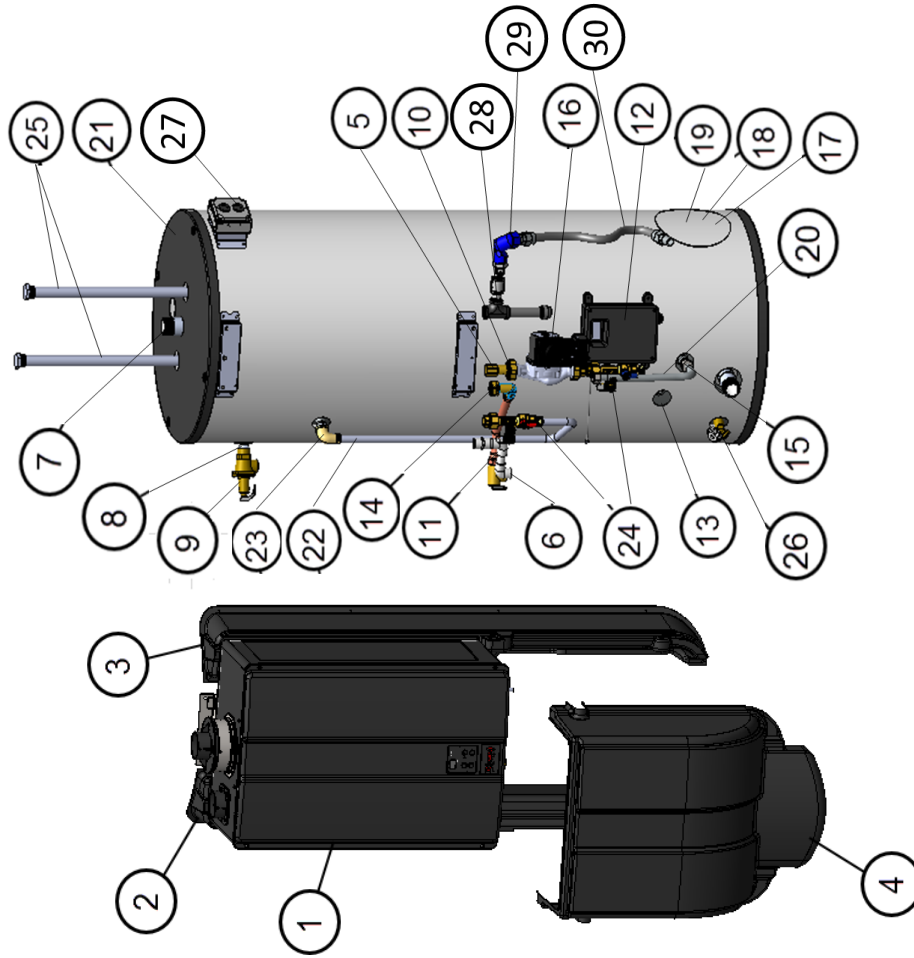



# 10. Warranty

## Limited Warranty for Demand Duo H-Series

### What Is Covered?

The Rinnai Standard Limited Warranty covers any defects in materials or workmanship when the product is installed and operated according to Rinnai written installation instructions, subject to the terms within this Limited Warranty document. This Limited Warranty applies only to products that are installed correctly in the United States and Canada. Improper installation may void this Limited Warranty. In order for this warranty to apply, it is required that you use a trained and qualified professional who has attended a Rinnai installation training class before installing this water heater. This Limited Warranty coverage as set out in the table below extends to the original purchaser and subsequent owners, but only while the product remains at the site of the original installation. This Limited Warranty only extends to the first / original installation of the product and terminates if the product is moved or reinstalled at a new location.

Item	Warranty Coverage
Heat Exchanger*	8 Years
Storage Tank	6 Years
All Other Parts and Components	5 Years
Reasonable Labor	1 Year

\*The heat exchanger warranty will be 8 years or 12,000 operation hours, whichever occurs first.

#### Notes:

- From date of purchase, period of coverage is reduced to 8 years or 12,000 operation hours, whichever occurs first, if the Rinnai water heater temperature settings exceeds 160°F (71°C).
- The integrated controller has a 1 year warranty on parts.

### What Will Rinnai Do?

Rinnai will repair or replace the covered product or any part or component that is defective in materials or workmanship as set forth in the above table. Rinnai will pay reasonable labor charges associated with the repair or replacement of any such part or component during the term of the labor warranty period. All repair parts must be genuine Rinnai parts. All repairs or replacements must be performed by a licensed professional who is properly trained to do the type of repair.

Replacement of the product may be authorized by Rinnai only at its sole discretion. Rinnai does not authorize any person or company to assume for it any obligation or liability in connection with the replacement of the product. If Rinnai determines that repair of a product is not possible, Rinnai may replace the product with a comparable product at Rinnai's sole discretion. The warranty claim for product parts and labor may be denied if a component or product returned to Rinnai is found to be free of defects in material or workmanship; damaged by improper installation, use or operation; or damaged during return shipping.

### How Do I Get Service?

You must contact a trained and qualified professional for the repair of a product under this Limited Warranty. For the name of a trained and qualified professional, please contact your place of purchase, visit the Rinnai website ([www.rinnai.us](http://www.rinnai.us)), call Rinnai at 1-800-621-9419 or write to Rinnai at 103 International Drive, Peachtree City, Georgia 30269.

Proof of purchase is required to obtain warranty service. You may show proof of purchase with a dated sales receipt, or *by registering within 30 days of purchasing the product. To register your Rinnai Tankless Water Heater, please visit [www.rinnai.us](http://www.rinnai.us). For those without internet access, please call 1-866-RINNAI1 (746-6241).* Receipt of Registration by Rinnai will constitute proof-of-purchase for this product. Registration of product installed in new home construction may be verified with a copy of the closing papers provided by the initial home buyer. However, Registration is not necessary in order to validate this Limited Warranty.

## What Is Not Covered?

This Limited Warranty does not cover any failures or operating difficulties due to the following:

- Accident, abuse, or misuse
- Alteration of the product or any component part
- Misapplication of this product
- Improper installation (such as but not limited to)
  - Product being installed in a corrosive environment
  - Condensate damage
  - Improper venting
  - Incorrect gas type
  - Incorrect gas or water pressure
  - Absence of a drain pan under the appliance
- Improper maintenance (such as but not limited to scale build-up, freeze damage, or vent blockage)
- Incorrect sizing
- Any other cause not due to defects in materials or workmanship
- Problems or damage due to fires, flooding, electrical surges, freezing or any acts of God
- Any damage caused by poor water quality
- Operating the water heater with anything other than potable water at all times
- Force majeure

There is no warranty coverage on product installed in a closed loop application, commonly associated with space heating only applications.

This Limited Warranty does not apply to any product whose serial number or manufacture date has been defaced.

This Limited Warranty does not cover any product used in an application that uses chemically treated water such as a pool or spa heater.

## Limitation on Warranties

No one is authorized to make any other warranties on behalf of Rinnai America Corporation. Except as expressly provided herein, there are no other warranties, expressed or implied, including, but not limited to warranties of merchantability or fitness for a particular purpose, which extend beyond the description of the warranty herein.

Any implied warranties of merchantability and fitness arising under state law are limited in duration to the period of coverage provided by this Limited Warranty, unless the period provided by state law is less. Some states do not allow limitations on how long an implied Limited Warranty lasts, so the above limitation may not apply to you.

Rinnai shall not be liable for indirect, incidental, special, consequential or other similar damages that may arise, including lost profits, damage to person or property, loss of use, inconvenience, or liability arising from improper installation, service or use. Some states do not allow the exclusion or limitation of incidental or consequential damages, so the above limitation may not apply to you.

This Limited Warranty gives you specific legal rights, and you may also have other rights which vary from state to state.

[www.rinnai.us/warranty](http://www.rinnai.us/warranty)

## Creating a Healthier Way of Living

Learn more about Rinnai high-performance Tankless Water Heaters, Hybrid Water Heating Systems, Boilers, Vent-Free Fan Convector and EnergySaver® Direct Vent Wall Furnaces at:

**[rinnai.us](http://rinnai.us) | [rinnai.ca](http://rinnai.ca)**

---

**Rinnai**®

**Rinnai America Corporation**

103 International Drive | Peachtree City, GA 30269  
1-800-621-9419 | [rinnai.us](http://rinnai.us) | [rinnai.ca](http://rinnai.ca)

04/2020

10000684