

INSTALLATION, OPERATION, SERVICE & PARTS LIST FOR ROUNDUP STEAM FOOD WARMERS

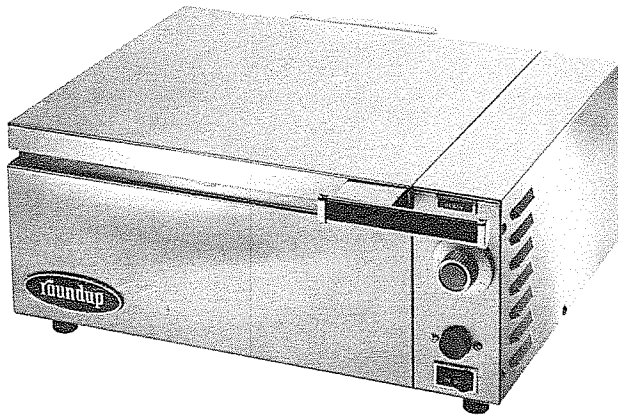

Your Roundup Steam Food Warmer has been tested and checked for proper operation before leaving the factory. Please examine the steamer for any hidden damage that may have occurred during shipping. IF UNIT IS DAMAGED, CONTACT THE CARRIER IMMEDIATELY AND FILE A DAMAGE CLAIM WITH THEM. YOU WILL REQUIRE ALL PACKING MATERIAL WHEN FILING A CLAIM.

GENERAL DESCRIPTION:

The Roundup Food Warmer produces a superheated dry steam, using plain tap water for heating and reconstituting food products with a minimum amount of attention.

SPECIFICATIONS:

FW Series: 1500 Watts, 12.5 Amps, 120 Volts, 60HZ (230 Volts 50 HZ Available) 6 foot grounded power cord.

FWT Series: 1750 Watts, 14.6 Amps, 120 Volts, 60HZ (230 Volts 50HZ Available) 6 foot grounded power cord.

FWF Series: 3000 Watts, 13.1 Amps, 230 Volts, 60HZ, 6 foot grounded power cord.

Dimensions—

Model	Width	Depth	Height
FW	16½" 419 mm	15¼" 367 mm	8" 203 mm
FWT	20" 508 mm	15¼" 307 mm	8" 203 mm
FWF	25¼" 641 mm	15¼" 387 mm	9¼" 235 mm

Food Capacity —

FW — Half size steam table pan, 2⅞" deep
 FWT — Two-thirds size steam table pan, 2⅞" deep
 FWF — Full size steam table pan, 4" deep

WATER SUPPLY

The Roundup Steam Food Warmers are designed to operate using plain tap water. **FW-100, 115, 160, FWT-100, 115, 160:** These models have a self-contained water reservoir and are portable. To fill the water reservoir, open the sliding hatch cover on the top of the Food Warmer. Pour in cold tap water. The reservoir has a capacity of approximately 3 quarts. No damage will occur if the unit is allowed to run dry.

FW-200, 215, 260, FWT-200, 215, 260, FWF-260C: These models require direct water connection. They come supplied with an installation kit. Connect the ¼" compression fitting to your water supply. Insert the quick disconnect to the water connection in the rear of the Food Warmer cabinet. When water connections are complete, check all water fittings for leaks.

NOTE: Water supply must not exceed 40 PSI. If water pressure is over 40 PSI, a water pressure regulator must be installed to prevent flooding. Set water pressure between 20 PSI and 40 PSI. A water pressure regulator is available from Roundup Food Equipment Division. Call your dealer and specify part #217K105.

OPERATION:

After electrical and water hookup is made, push black rocker switch to "ON" position (pilot light on) and allow 20 minutes to warm up. Open the cover by using the handle. Place the product to be steamed into the pan and close the cover. The FW & FWT 100 & 200 Food Warmers operate with push button simplicity. To operate, push large black button momentarily which will allow water into the generator, creating steam. On initial installation, several operations of push button will be required until piping in system is filled. Water will enter the generator and produce steam as long as the button is pushed.

The FW & FWT 115, 160, 215, 260, and FWF-260C Food Cookers can be used with an automatic timed shot or an instant shot of steam. Set the timer to the desired cooking time and push the orange center button on the dial. A timed shot of steam will be delivered every 20 seconds until the cycle is complete. The red "READY" light will signal the end of the cycle. An individual shot of steam is delivered by depressing the black momentary switch.

NOTE: The timer dial will not move down to zero mark. This allows for repeating the time cycle for the same product.

The FWF-260C has a "continuous toggle switch marked "T" and "C" ("T" = timer, "C" = continuous). Once the continuous switch is turned to "C," the FWF-260C will deliver a measured amount of steam every 20 seconds until the continuous switch is turned off by returning the toggle switch to "T" position.

NOTE: To prevent flooding of the generator be sure continuous switch is in "T" position when turning on the FWF-260C.

MODELS FW- OR FWT-100, 115 AND 160

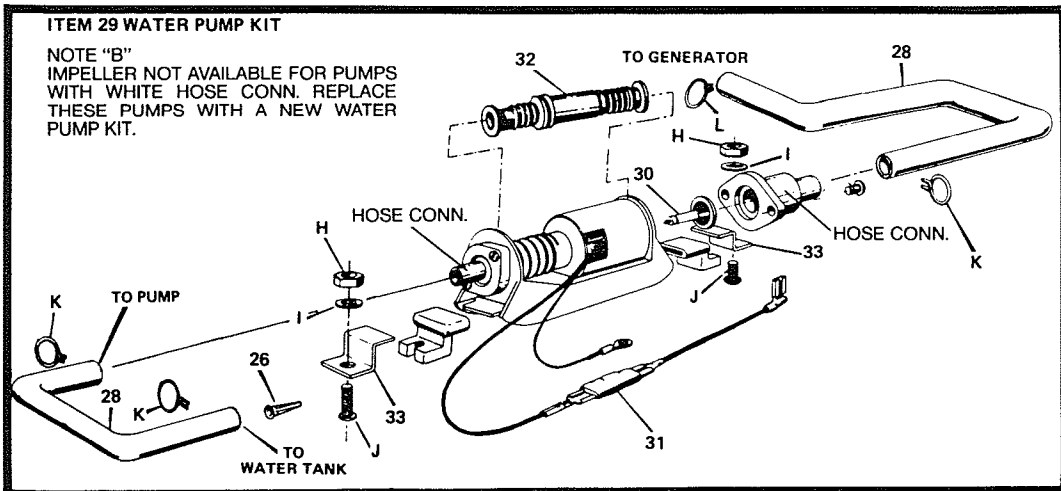
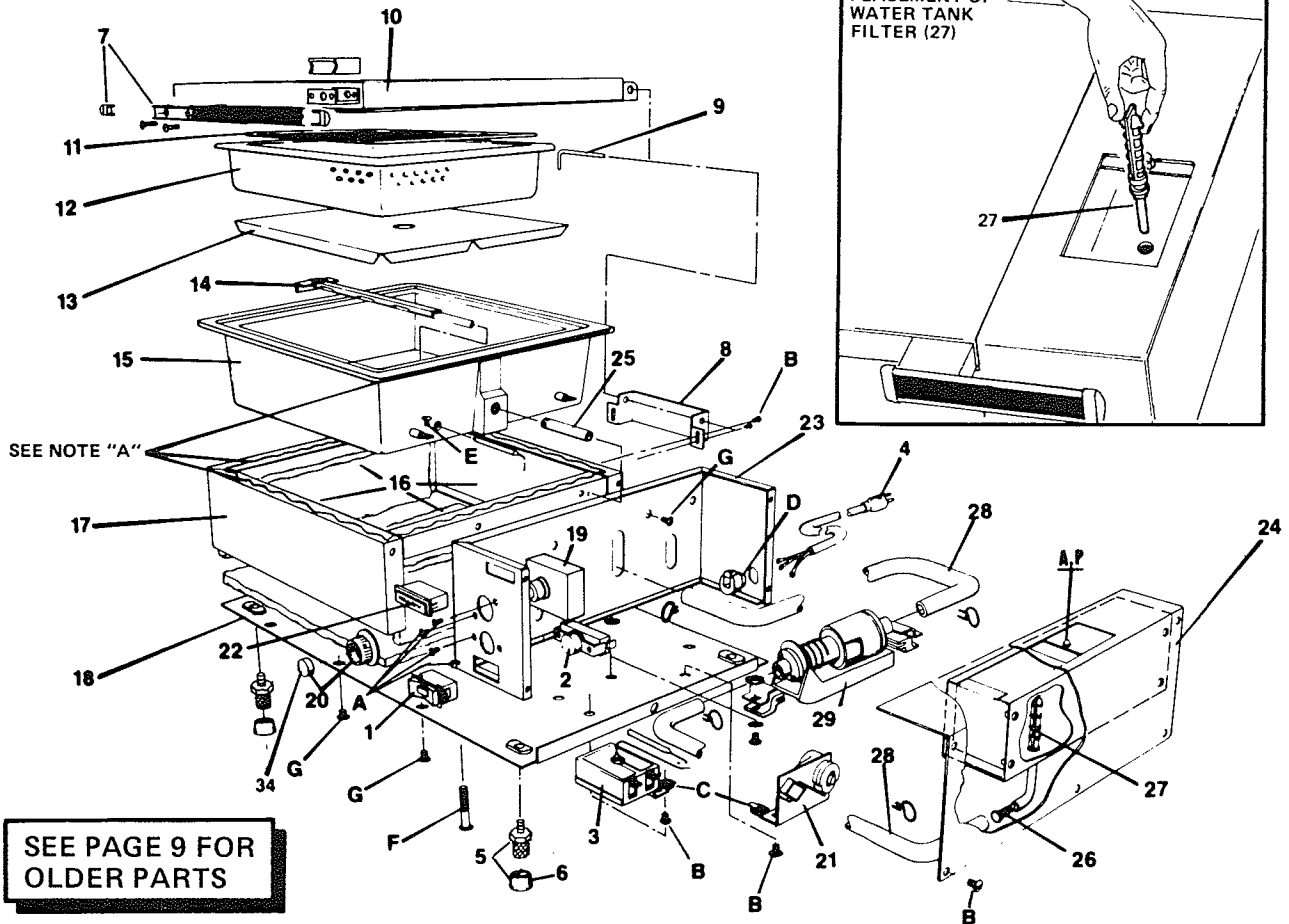
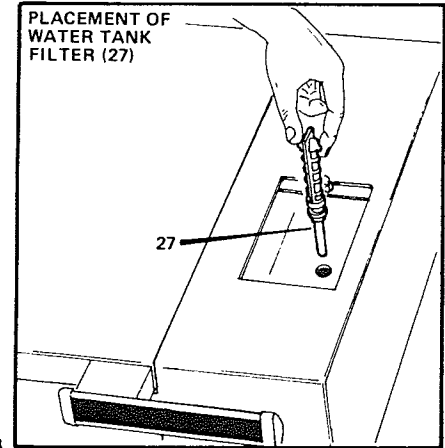
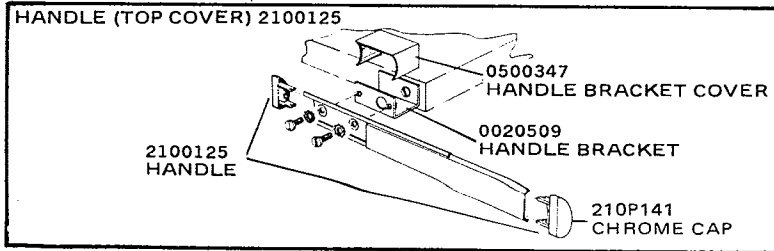

NOTE "A"
IF ITEM NO. 15 IS SEPARATED FROM ITEM NO. 17 AND 23, A NEW SEAL OF SILICONE (G. E. OR DOW CORNING RTV) MUST BE APPLIED AROUND ENTIRE MATING SURFACES AS SHOWN TO RESEAL ITEM NO. 15 TO ITEM NO. 17 AND 23.

WE RECOMMEND DOW CORNING PART NO. 732AL. (ALUMINUM COLOR)
FOR NEAREST DISTRIBUTOR, CALL TOLL FREE 1-800-248-2481.

PARTS LIST

ITEM	PART NO.	DESCRIPTION	QTY.
1	401 0104	ROCKER SWITCH	1
2	401 0106	MOMENTARY SWITCH (INCLUDES TWO ITEM A)	1
3	403 0157	THERMOSTAT (INCL'DS TWO ITEM B & TWO ITEM C)	1
▲	403 0106	THERMOSTAT (INCL'DS TWO ITEM B & TWO ITEM C)	1
4	070 0119	POWER CORD (INCLUDES ONE ITEM D)	1
	*070 0112	POWER CORD (MODELS FWT FOR CANADA) (INCLUDES ONE ITEM D)	1
5	210 K104	LEG KIT (SET OF FOUR) (INCLUDES ITEM 6)	1
6	210 K108	RUBBER FOOT TIP KIT (SET OF FOUR)	1
7	210 0125	HANDLE KIT (SEE PARTS VIEW)	1
	*210 K101	HANDLE KIT (INCL'DS TWO ITEM N & TWO ITEM O)	1
8	050 0290	BASE HINGE	1
9	080 0107	HINGE PIN	1
10	001 0120	TOP COVER (MODEL FW) (INCLUDES ITEM 7)	1
	001 0139	TOP COVER (MODEL FWT) (INCLUDES ITEM 7)	1
11	080 0106	TRIVET (MODEL FW)	1
	080 0109	TRIVET (MODEL FWT)	1
	001 0224	RAISED TRIVET (MODEL FW)	1
	001 0242	RAISED TRIVET (MODEL FWT)	1
12	213 0102	PERFORATED PAN (MODEL FW)	1
	213 0103	PERFORATED PAN (MODEL FWT)	1
13	050 0299	DIFFUSER PAN (MODEL FW)	1
	050 0323	DIFFUSER PAN (MODEL FWT)	1
14	001 0145	SPRAY TUBE (MODEL FW)	1
	001 0146	SPRAY TUBE (MODEL FWT)	1
15	010 0121	GENERATOR (MODEL FW) (INCLUDES TWO ITEM E & TWO ITEM F)	1
	010 0124	GENERATOR (MODEL FWT) (INCLUDES TWO ITEM E & TWO ITEM F)	1
16	040 0116	INSULATION SET (MODEL FW)	1
	040 0117	INSULATION SET (MODEL FWT)	1
17	002 0105	MAIN HOUSING (MODEL FW)	1
	002 0123	MAIN HOUSING (MODEL FWT)	1
18	002 0127	BASE PLATE (MODEL FW-100, 115, 160)	1
	002 0128	BASE PLATE (MODEL FWT-100, 115, 160)	1
19	402 0102	TIMER (15 MINUTE TIMER MODELS ONLY) (INCLUDES 1 ITEM 20 & 2 ITEM A)	1
	402 0103	TIMER (60 MINUTE TIMER MODELS ONLY) (INCLUDES 1 ITEM 20 & 2 ITEM A)	1
20	210 0120	TIMER DIAL (15 MINUTES)	1
	210 0121	TIMER DIAL (60 MINUTES)	1
21	402 0106	PULSE TIMER (TIMER MODELS ONLY) (INCLUDES 2 ITEM B & 2 ITEM C)	1

ITEM	PART NO.	DESCRIPTION	QTY.
22	406 0102	READY LIGHT (TIMER MODELS ONLY)	1
23	050 0266	ELECTRICAL HOUSING (MODELS WITHOUT TIMER)	1
	050 0342	ELECTRICAL HOUSING (MODELS WITH TIMER)	1
24	001 0140	ACCESS COVER (INCLUDES WATER TANK)	1
25	219 0101	BRASS PIPE	1
26	209 0101	FILTER-WATER LINE	1
27	001 0159	FILTER-WATER TANK	1
28	202 K101	SILICONE TUBE KIT	1
29	404 K101	WATER PUMP KIT	1
30	404 0108	CHECK VALVE	1
31	404 0109	PUMP DIODE	1
32	4040131	IMPELLER (SEE NOTE "B")	1
33	050 0281	PUMP MOUNT BRACKET	2
34	218 0109	TIMER DIAL BUTTON	1
35	070 0121	WIRE SET (FW-100, FWT-100)	REF.
36	070 0137	WIRE SET (FW-115, 160/FWT-115, 160)	REF.

ADDITIONAL HARDWARE (ITEMS A THRU P) ARE AVAILABLE ONLY IN PACKAGES OF TEN (10) EACH.

ITEM	PART NO.	DESCRIPTION	QTY.
A	306 P104	SCREW 6-32 x 1/4 LG. TRUSS HD. ST. STL.	1
B	308 P104	SCREW 8-32 x 3/8 LG. TRUSS HD. ST. STL.	2
C	300 P102	TINNERMAN 8-32	1
D	040 P112	STRAIN RELIEF	1
E	308 P118	SCREW 8-32 x 3/8 LG. BINDER HD. NICKEL PLATED	1
F	325 P106	SCREW 1/4-20 x 2 LG. TRUSS HD. CAD. PLATED	1
G	308 P113	SCREW 8-32 x 3/8 LG. SELF TAPPAN HD. CAD. PLATED	2
H	308 P101	NUT 8-32 ST. STL.	1
I	308 P102	#8 INTERNAL TOOTH LOCK-WASHER CAD. PLATED	1
J	308 P108	SCREW 8-32 x 3/8 LG. TRUSS HD. ST. STL.	1
K	211 P103	HOSE CLAMP NOM. 1/2 I.D.	1
L	211 P102	HOSE CLAMP NOM. 7/16 I.D.	1
M	211 P101	HOSE CLAMP NOM. 3/8 I.D.	1
N	310 P105	SCREW 10-24 X 1-1/4 LG. PAN HD. CAD. PLATED	1
O	210 P124	HANDLE SPACER	1
P	306 P107	ACORN NUT #6-32 ST. STL.	1

FOR FW-100TS AND FWT-100TS MODELS REFER TO PAGE 8 FOR PARTS LIST.

▲ UNITS BUILT PRIOR TO JULY, 1981 REQUIRE THIS P/N. ORDER THIS P/N AND SPECIFY "NO SUBSTITUTION".

*SEE PAGE 9 FOR OLDER PARTS.

MODELS FW- OR FWT-200, -215, AND -260

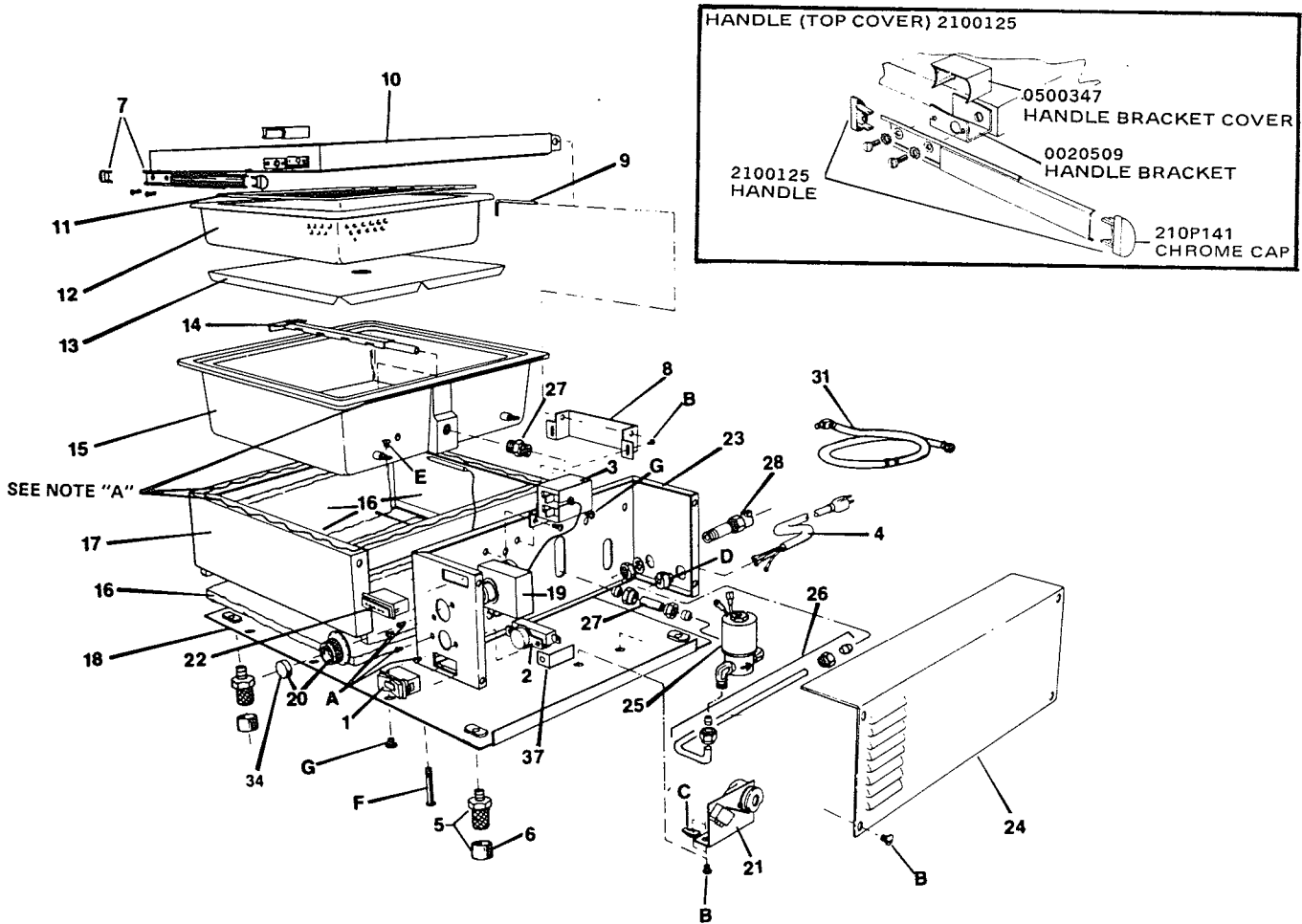

SEE PAGE 9 FOR OLDER PARTS

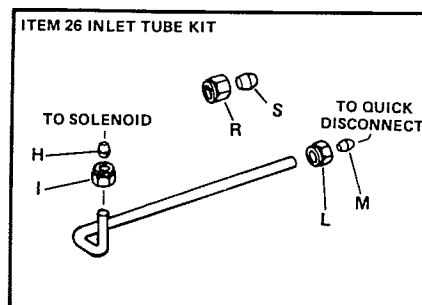
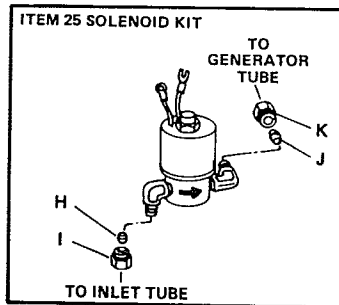

NOTE "A"

IF ITEM NO. 15 IS SEPARATED FROM ITEM NO. 17 AND 23, A NEW SEAL OF SILICONE (G. E. OR DOW CORNING RTV) MUST BE APPLIED AROUND ENTIRE MATING SURFACES AS SHOWN TO RESEAL ITEM NO. 15 TO ITEM NO. 17 AND 23.

WE RECOMMEND DOW CORNING PART NO. 732AL. (ALUMINUM COLOR)

FOR NEAREST DISTRIBUTOR CALL TOLL FREE 1-800-248-2481

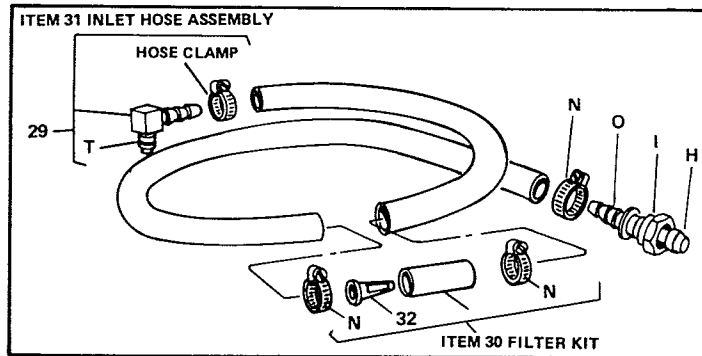

PARTS LIST

ITEM	PART NO.	DESCRIPTION	QTY.
1	401 0104	ROCKER SWITCH	1
2	401 0106	MOMENTARY SWITCH (INCLUDES 2 ITEM A)	1
3	403 0157	THERMOSTAT (INCL'DS 2 ITEM B & 2 ITEM C)	1
▲	403 0106	THERMOSTAT (INCL'DS 2 ITEM B & 2 ITEM C)	1
4	070 0119	POWER CORD (INCLUDES 1 ITEM D)	1
	*070 0112	POWER CORD (MODELS FWT FOR CANADA) (INCLUDES 1 ITEM D)	1
5	210 K104	LEG KIT (SET OF FOUR) (INCLUDES ITEM 6)	1
6	210 K108	RUBBER FOOT TIP KIT (SET OF FOUR)	1
7	210 0125	HANDLE KIT (SEE PARTS VIEW)	1
	*210 K101	HANDLE KIT (INCL'DS 2 ITEM P & 2 ITEM Q)	1
8	050 0290	HINGE BASE	1
9	080 0107	HINGE PIN	1
10	001 0120	TOP COVER (MODEL FW) (INCLUDES ITEM 7)	1
	001 0139	TOP COVER (MODEL FWT) (INCLUDES ITEM 7)	1
11	080 0106	TRIVET (MODEL FW)	1
	080 0109	TRIVET (MODEL FWT)	1
	001 0224	RAISED TRIVET (MODEL FW)	1
	001 0242	RAISED TRIVET (MODEL FWT)	1
12	213 0102	PERFORATED PAN (MODEL FW)	1
	213 0103	PERFORATED PAN (MODEL FWT)	1
13	050 0299	DIFFUSER PAN (MODEL FW)	1
	050 0323	DIFFUSER PAN (MODEL FWT)	1
14	001 0145	SPRAY TUBE (MODEL FW)	1
	001 0146	SPRAY TUBE (MODEL FWT)	1
15	010 0121	GENERATOR (MODEL FW) (INCLUDES 2 ITEM E & 2 ITEM F)	1
	010 0124	GENERATOR (MODEL FWT) (INCLUDES 2 ITEM E & 2 ITEM F)	1
16	040 0116	INSULATION SET (MODEL FW)	1
	040 0117	INSULATION SET (MODEL FWT)	1
17	002 0105	MAIN HOUSING (MODEL FW)	1
	002 0123	MAIN HOUSING (MODEL FWT)	1
18	002 0113	BASE PLATE (MODEL FW, 200, 215, 260)	1
	002 0125	BASE PLATE (MODEL FWT, 200, 215, 250)	1
19	402 0102	TIMER (15 MINUTE TIMER MODELS ONLY) (INCLUDES 1 ITEM 20 & 2 ITEM A)	1
	402 0103	TIMER (60 MINUTE TIMER MODELS ONLY) (INCLUDES 1 ITEM 20 & 2 ITEM A)	1
20	210 0120	TIMER DIAL (15 MINUTES)	1
	210 0121	TIMER DIAL (60 MINUTES)	1
21	402 0106	PULSE TIMER (TIMER MODELS ONLY) (INCLUDES 2 ITEM B & 2 ITEM C)	1
22	406 0102	READY LIGHT (TIMER MODELS ONLY)	1
23	050 0278	ELECTRICAL HOUSING (MODELS WITHOUT TIMER)	1
	050 0277	ELECTRICAL HOUSING (MODELS WITH TIMER)	1
24	050 0280	ACCESS COVER	1

ITEM	PART NO.	DESCRIPTION	QTY.
25	◆002 0407 *404 K103	SOLENOID KIT SOLENOID KIT	1 1
26	200 K125 *200 K106	INLET TUBE KIT INLET TUBE KIT	1 1
27	200 K124	GENERATOR TUBE KIT	1
28	208 0104 *208 0102	QUICK DISCONNECT (BODY) QUICK DISCONNECT (BODY)	1 1
29	208 0103 *208 K102	QUICK DISCONNECT (INSERT) QUICK DISCONNECT (INSERT)	1 1
30	209 K101	FILTER KIT (INLINE)	1
31	001 0123	INLET HOSE ASSEMBLY	1
32	209 0101	INLINE FILTER	1
33	203 K102	POLY BRAID HOSE KIT (2 PCS)	1
34	218 0109	TIMER DIAL BUTTON	1
35	070 0118	WIRE SET (FW-200, FWT-200)	REF.
36	070 0122	WIRE SET (FW-215, 260/FWT-215, 260)	REF.

◆404K117 SKINNER VALVE REPAIR KIT

*SEE PAGE 9 FOR OLDER PARTS.

FOR FW-200TS AND FWT-200TS MODELS REFER TO PAGE 8 FOR PARTS LIST.

▲ UNITS BUILT PRIOR TO JULY, 1981 REQUIRE THIS P/N. ORDER THIS P/N AND SPECIFY "NO SUBSTITUTION".

KITS NEEDED TO CHANGE FROM PLASTIC BODY SOLENOID TO ALL METAL SOLENOID

FW & FWT-215-260	002 K102
FW & FWT-200-TS	002 K103
FW & FWT-200	002 K104

ADDITIONAL HARDWARE (ITEMS A THRU Q) ARE AVAILABLE ONLY IN PACKAGES OF TEN (10) EACH.

ITEM	PART NO.	DESCRIPTION	QTY.
A	306 P104	SCREW 6-32 x 1/4 LG. TRUSS HD. ST. STL.	1
B	308 P104	SCREW 8-32 x 3/8 LG. TRUSS HD. ST. STL.	2
C	300 P102	TINNERMAN 8-32	1
D	040 P112	STRAIN RELIEF	1
E	308 P118	SCREW 8-32 x 3/8 LG. BINDER HD. NICKEL PLATED	1
F	325 P106	SCREW 1/4-20 x 2 LG. TRUSS HD. CAD. PLATED	1
G	308 P113	SCREW 8-32 x 3/8 LG. SELF TAP PAN HD. CAD. PLATED	2
H	204 P109	COMPRESSION SLEEVE 1/4	1
I	204 P108	COMPRESSION NUT 1/4	1
J	204 P112	COMPRESSION NUT 3/8	1
K	204 P113	COMPRESSION SLEEVE 3/8	1
L	205 P102	COMPRESSION NUT 1/4 (POLY FLO)	1
M	205 P101	COMPRESSION SLEEVE 1/4 (POLY FLO)	1
N	211 P104	WORM CLAMP	1
O	204 P106	TUBE-HOSE ADAPTOR	1
P	310 P105	SCREW 10-24 x 1-1/4 LG. PAN HD. CAD. PLATED	1
Q	210 P124	HANDLE SPACER	1
R	204 P108	COMPRESSION NUT	1
S	204 P109	COMPRESSION SLEEVE	1
T	020 P116	"O" RING	1

MODEL FWF-260C

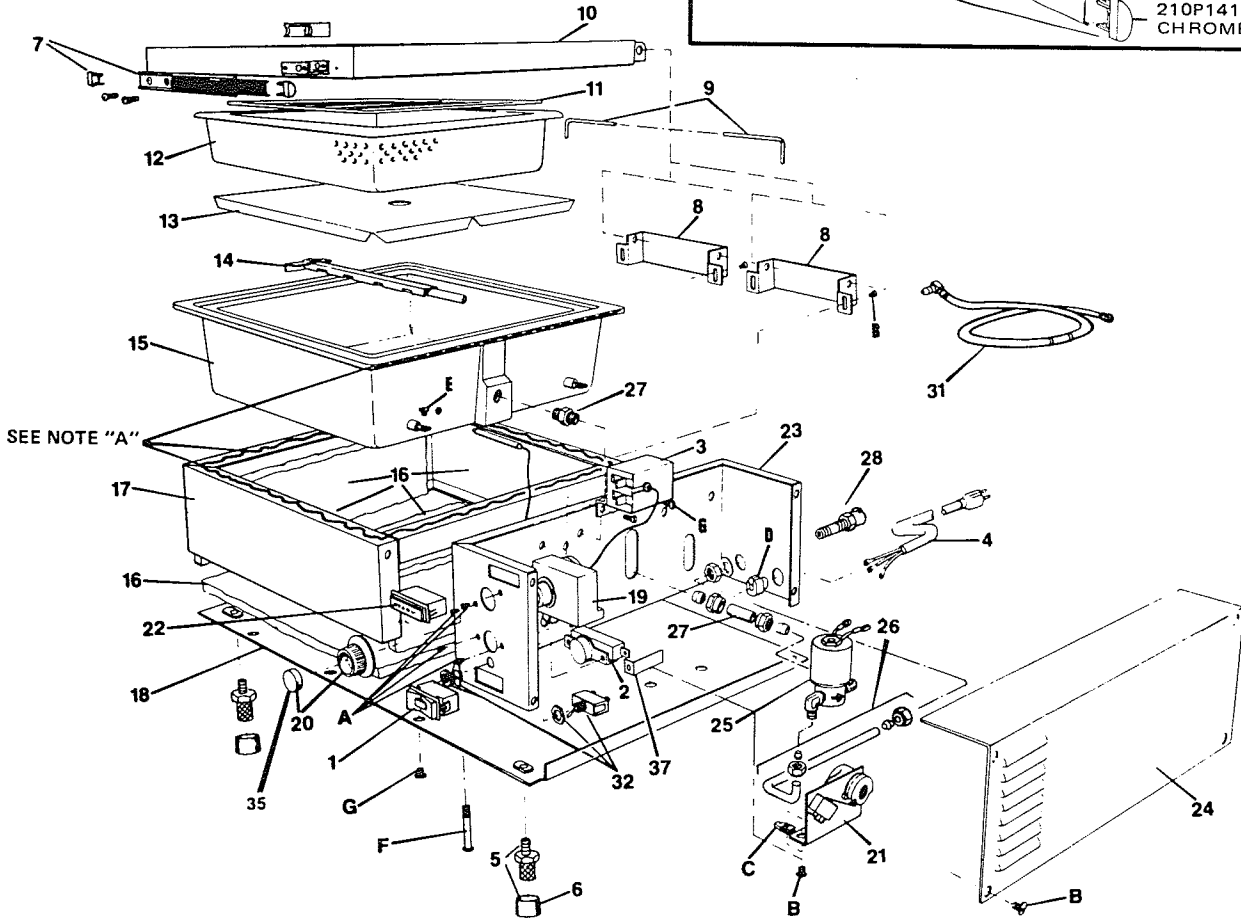
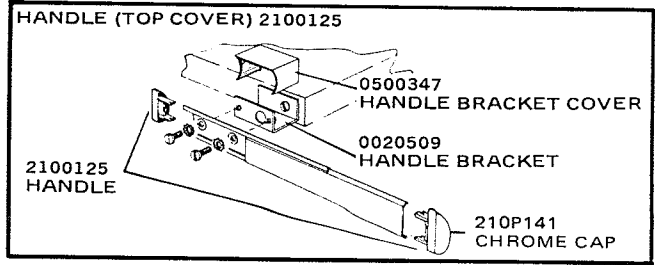

**SEE PAGE 8 FOR
OLDER PARTS**

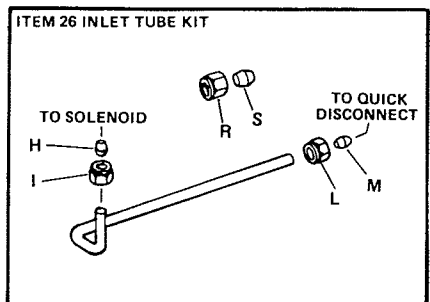
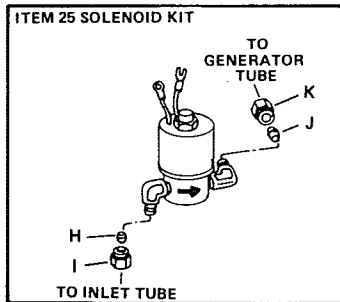

NOTE "A"
IF ITEM NO. 15 IS SEPARATED FROM ITEM NO. 17 AND 23, A NEW SEAL OF SILICONE (G. E. OR DOW CORNING RTV) MUST BE APPLIED AROUND ENTIRE MATING SURFACES AS SHOWN TO RESEAL ITEM NO. 15 TO ITEM NO. 17 AND 23.
WE RECOMMEND DOW CORNING PART NO. 732AL. (ALUMINUM COLOR)
FOR NEAREST DISTRIBUTOR
CALL TOLL FREE 1-800-248-2481

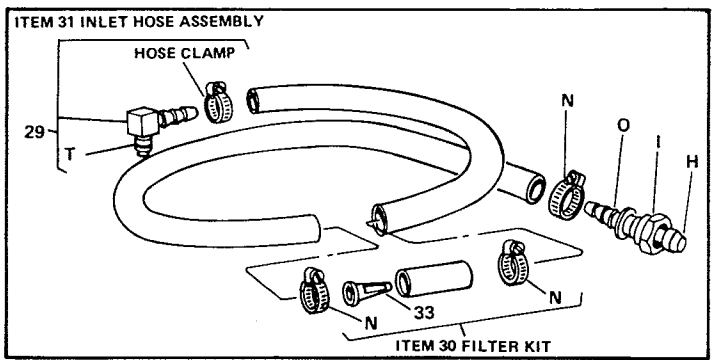

PARTS LIST

ITEM	PART NO.	DESCRIPTION	QTY.
1	401 0105	ROCKER SWITCH	1
2	401 0106	MOMENTARY SWITCH (INCLUDES 2 ITEM A)	1
3	403 0157	THERMOSTAT (INCL'DS 2 ITEM B & 2 ITEM C)	1
	▲ 403 0106	THERMOSTAT (INCL'DS 2 ITEM B & 2 ITEM C)	1
4	070 0139	POWER CORD (INCLUDES 1 ITEM D)	1
5	210 K104	LEG KIT (SET OF FOUR) (INCLUDES ITEM 6)	1
6	210 K108	RUBBER FOOT TIP KIT (SET OF FOUR)	1
7	210 0125	HANDLE KIT	1
	*210 K101	HANDLE KIT (INCL'DS 2 ITEM P & 2 ITEM Q)	1
8	050 0437	BASE HINGE	2
9	080 0107	HINGE PIN	2
10	001 0135	TOP COVER (INCLUDES ITEM 7)	1
11	080 0113	TRIVET	1
12	213 0104	PERFORATED PAN	1
13	050 0366	DIFFUSER PAN	1
14	001 0147	SPRAY TUBE	1
15	010 0123	GENERATOR (INCLUDES 2 ITEM E & 2 ITEM F)	1
16	040 0118	INSULATION SET	1
17	002 0147	MAIN HOUSING	1
18	002 0132	BASE PLATE	1
19	402 0108	TIMER (60 MINUTES) (INCLUDES 1 ITEM 20 & 2 ITEM A)	1
20	210 0121	TIMER DIAL (60 MINUTES)	1
21	402 0107	PULSE TIMER (INCLUDES 2 ITEM B & 2 ITEM C)	1
22	406 0103	READY LIGHT	1
23	050 0362	ELECTRICAL HOUSING	1
24	050 0363	ACCESS COVER	1
25	◆002 0402	SOLENOID KIT	1
	*404 K104	SOLENOID KIT	1
26	200 K125	INLET TUBE KIT	1
	*200 K108	INLET TUBE KIT	1
27	200 K109	GENERATOR TUBE KIT	1
28	208 0104	QUICK DISCONNECT (BODY) (SEE PARTS VIEW)	1
	*208 0102	QUICK DISCONNECT (BODY)	1
29	208 0103	QUICK DISCONNECT KIT (INSERT)	1
	*208 K102	QUICK DISCONNECT KIT (INSERT)	1

◆404K117 SKINNER VALVE REPAIR KIT

ITEM	PART NO.	DESCRIPTION	QTY.
30	209 K101	FILTER KIT (INLINE)	1
31	001 0123	INLET HOSE ASSEMBLY	1
32	401 0109	TOGGLE SWITCH	1
33	209 0101	INLINE FILTER	1
34	203 K102	POLY BRAID HOSE KIT (2-PCS)	1
35	218 0109	TIMER DIAL BUTTON	1
36	070 0140	WIRE SET	REF

002 K101 SOLENOID RETROFIT KIT PARTS NEEDED TO CHANGE FROM PLASTIC SOLENOID TO ALL METAL SOLENOID.

*SEE PAGE 9 FOR OLDER PARTS.

▲ UNITS BUILT PRIOR TO JULY, 1981 REQUIRE THIS P/N. ORDER THIS P/N AND SPECIFY "NO SUBSTITUTION".

ADDITIONAL HARDWARE (ITEMS A THRU Q) ARE AVAILABLE ONLY IN PACKAGES OF TEN (10) EACH.

ITEM	PART NO.	DESCRIPTION	Qty.
A	306 P104	SCREW 6-32 x 1/4 LG. TRUSS HD. ST. STL.	1
B	308 P104	SCREW 8-32 x 3/8 LG. TRUSS HD. ST. STL.	2
C	300 P102	TINNERMAN 8-32	1
D	040 P112	STRAIN RELIEF	1
E	308 P118	SCREW 8-32 x 3/8 LG. BINDER HD. NICKEL PLATED	1
F	325 P108	SCREW 1/4-20 x 1 3/8 LG. TRUSS HD. CADMIUM PLATED	1
G	308 P113	SCREW 8-32 x 3/8 LG. SELF TAP PAN HD. CADMIUM PLATED	2
H	204 P109	COMPRESSION SLEEVE 1/4	1
I	204 P108	COMPRESSION NUT 1/4	1
J	204 P113	COMPRESSION SLEEVE 3/8	1
K	204 P112	COMPRESSION NUT 3/8	1
L	205 P102	COMPRESSION NUT 1/4 (POLY FLO)	1
M	205 P101	COMPRESSION SLEEVE 1/4 (POLY FLO)	1
N	211 P104	WORM CLAMP	1
O	204 P106	TUBE-HOSE ADAPTOR	1
P	310 P105	SCREW 10-24 x 1-1/4 LG. PAN HD. CADMIUM PLATED	1
Q	210 P124	HANDLE SPACER	1
R	204 P108	COMPRESSION NUT	1
S	204 P109	COMPRESSION SLEEVE	1
T	020 P116	"O" RING	1

PARTS LIST

**STEAM FOOD WARMER
SUPPLEMENT**





— TIME SHOT —

For all model numbers ending with TS -
An adjustable shot of steam will be delivered every time the red momentary switch is depressed, thus, removing the guess work from one operator to the next.

ITEM	PART NO.	DESCRIPTION	QTY.
1	001 0384	T.S. ASSEMBLY (FW-100TS)	1
	001 0195	T.S. ASSEMBLY (FW-200TS)	1
2	402 0154	SOLID STATE TIMER (FW-100TS)	1
	402 0124	SOLID STATE TIMER (FW-200TS)	1
3	002 0526	T.S. CONTROL (FW-100TS)	1
	002 0194	T.S. CONTROL (FW-200TS)	1
4	050 0348	T.S. BRACKET	1
5	210 0115	KNOB	1
6	100 0585	LABEL (FW-100TS)	1
	100 0293	LABEL (FW-200TS)	1
7	308 P103	8-32 x 1/4 LG. TRUSS HD. SCREW ST. STL.	2
8	310 P129	#10-32 x 1 LG. RND. HD. SCREW ZINC PLATED	1
9	310 P102	#10 LOCKWASHER ZINC PLTD.	1
10	310 P101	#10 HEX NUT ZINC PLATED	1
11	070 0206	WIRE SET 100 T.S.	1
12	070 0207	WIRE SET 200 T.S.	1

**FW-100TS
(NEW)**



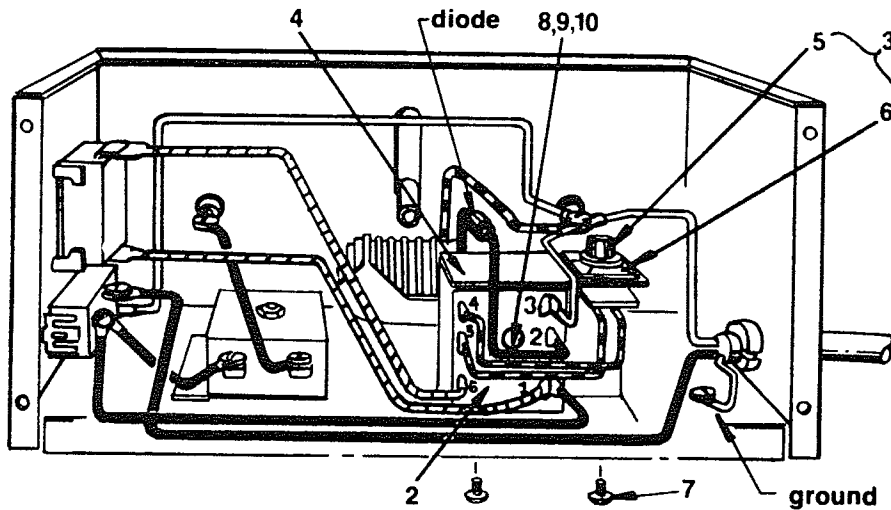

wire color code

-  black
-  white
-  blue
-  red



**FW-200TS
(NEW)**

wire color code

-  black
-  white
-  blue
-  red

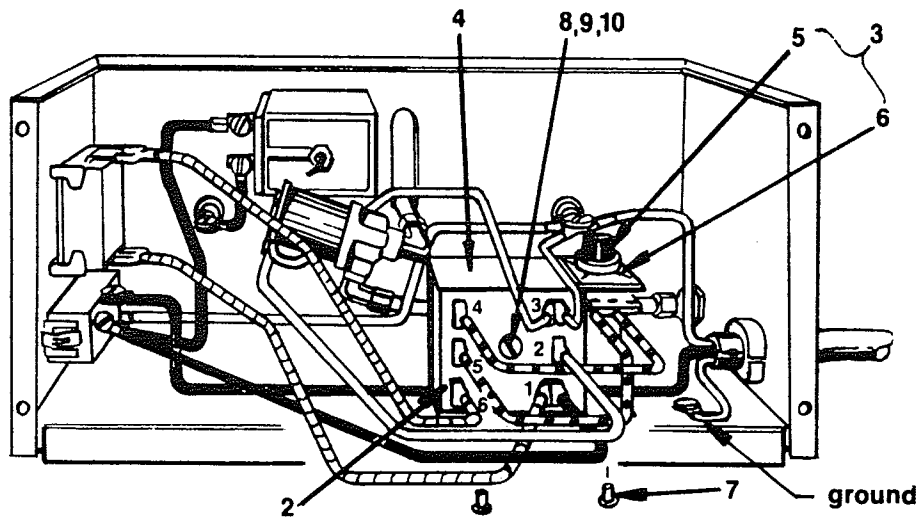

PARTS AVAILABLE FOR OLDER EQUIPMENT

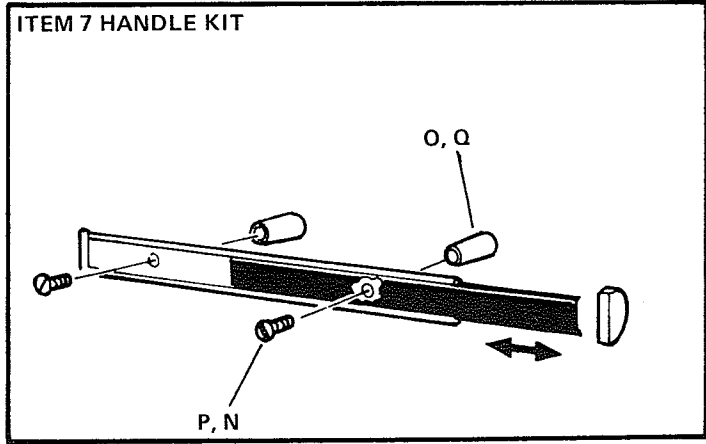
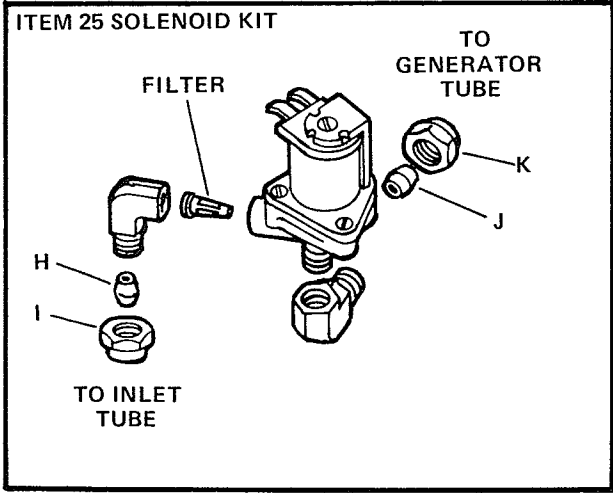
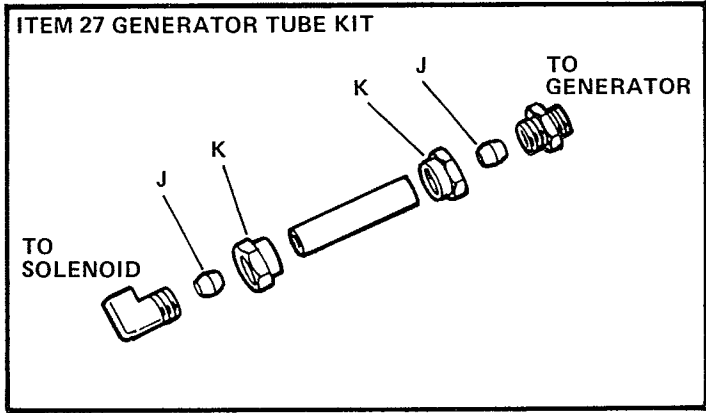
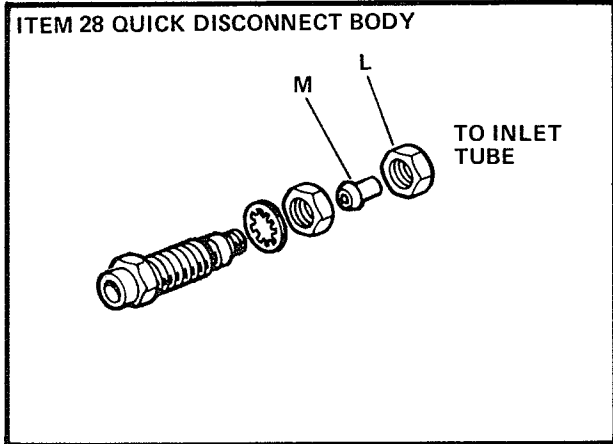
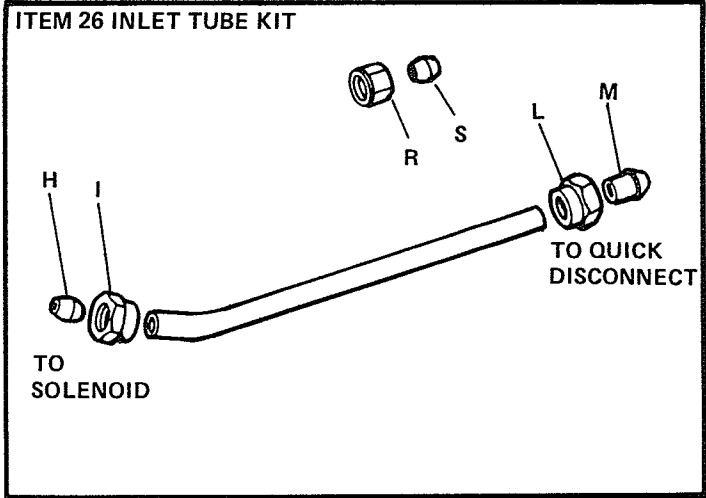
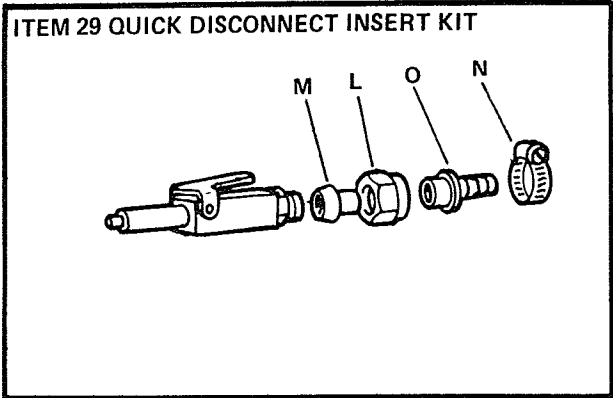

MODEL 100 wiring diagram FW-1500 watts FWT-1750 watts

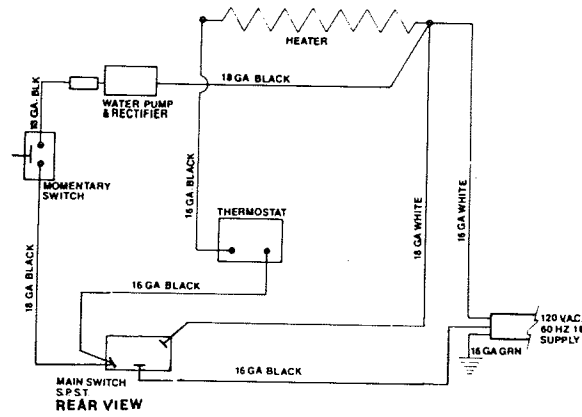

MODEL 115-160 wiring diagram FW-1500 watts FWT-1750 watts

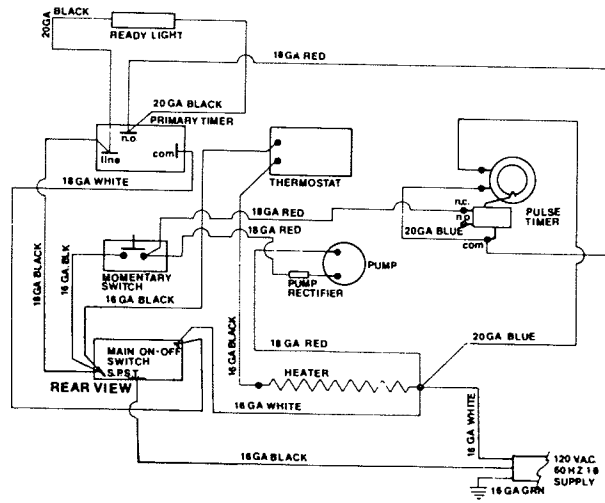

MODEL 200 wiring diagram FW-1500 watts FWT-1750 watts

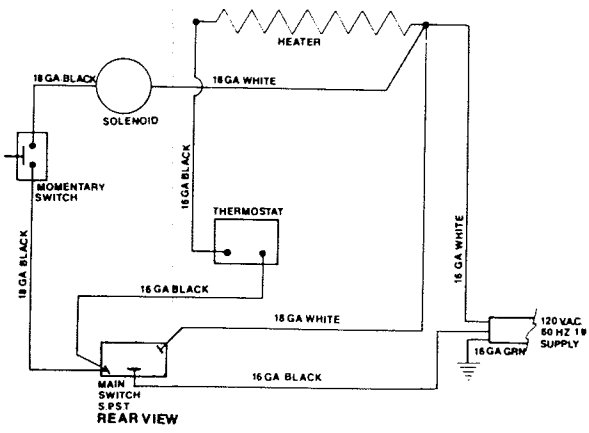

PLASTIC SOLENOID

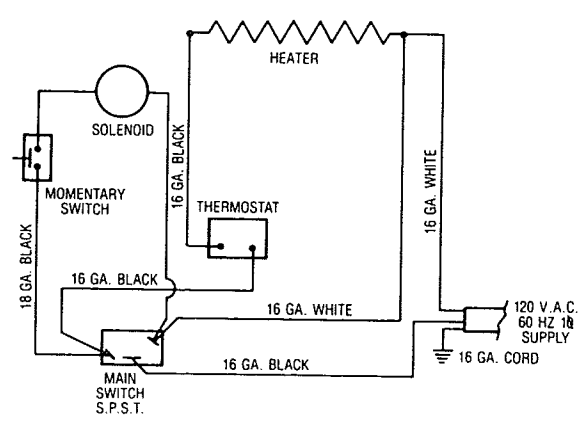

ALL METAL SOLENOID

MODEL 215-260 wiring Diagram FW-1500 watts FWT-1750 watts

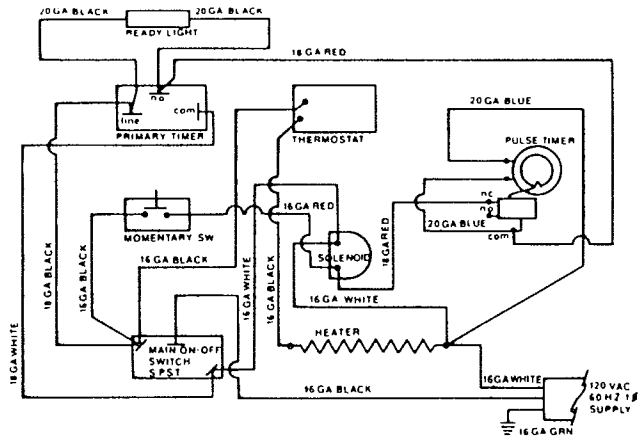

PLASTIC SOLENOID

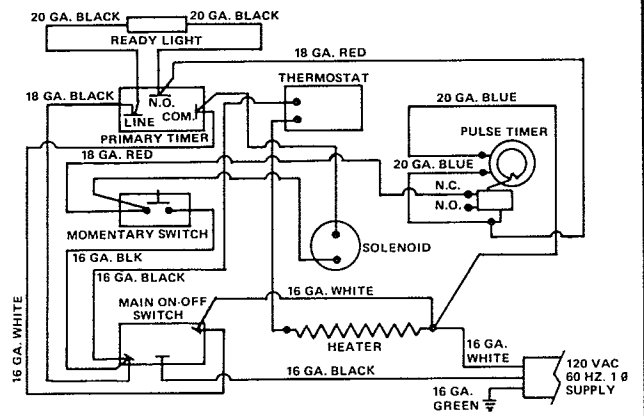

ALL METAL SOLENOID

MODEL FWF-260C FWF-3000 watts

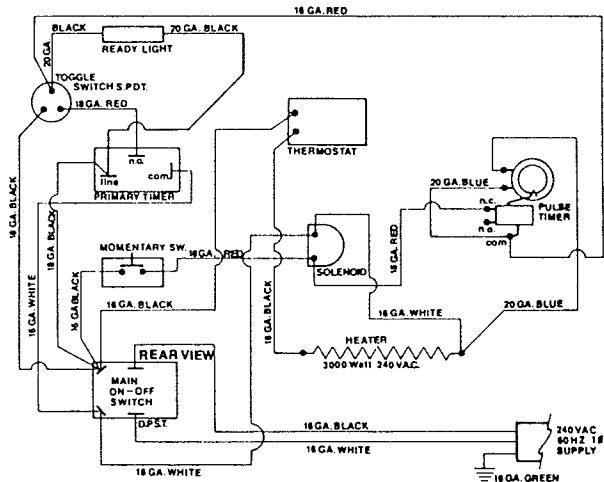

PLASTIC SOLENOID

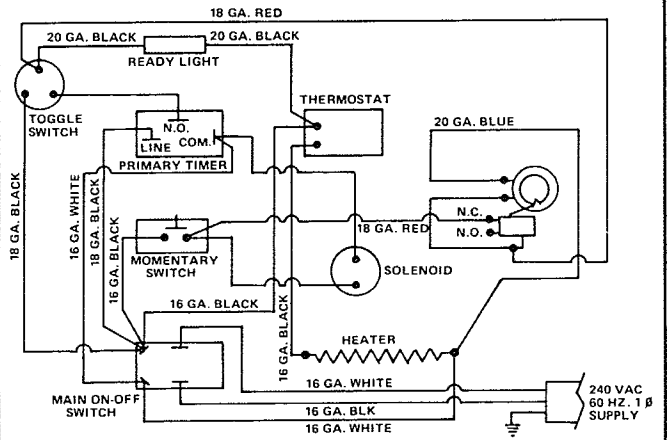

ALL METAL SOLENOID

MODEL FW-FWT 100TS wiring diagram

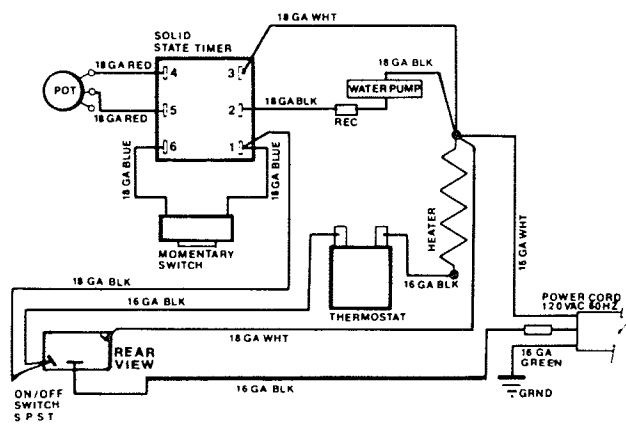

MODEL FW-FWT 200TS wiring diagram

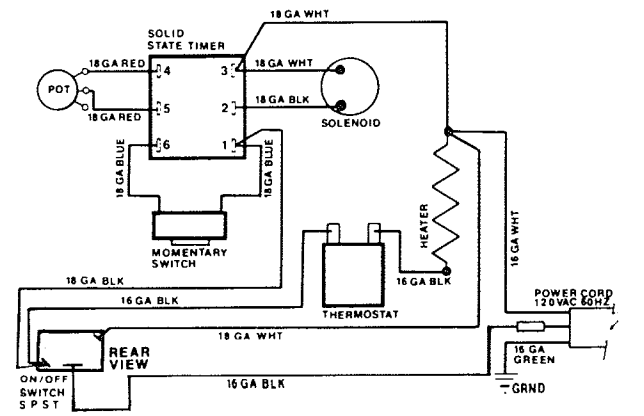

TROUBLE SHOOTING GUIDE

IMPORTANT: Servicing is to be performed by a qualified service person.

NOTE: Refer to electrical schematic for trouble shooting assistance.

PROBLEM	PROBABLE CAUSE	SOLUTION
Unit will not heat up. Rocker switch is on.	Unit is not plugged into outlet.	Plug power cord into outlet.
	Loose connections	Check continuity of wiring. Tighten as needed.
	Circuit breaker is off or has been tripped in main supply.	Turn on or reset circuit breaker.
	Defective wiring	Replace defective wiring. Review schematic drawing to insure proper wiring.
	Defective power cord	Check continuity of wires. Replace if defective.
	Defective rocker (on/off) switch	If there is power to the switch but not coming out replace the switch.
	Defective thermostat	If there is power to the thermostat but not coming out then replace the thermostat. Check the thermostat when unit is cold.
	Defective generator	If there is power through the rocker switch, check power across generator terminals with test light. If lit and generator does not heat up. Replace.
Unit heats up but will not steam.	Water tank out of water. (Self-contained models only)	Add water to reservoir.
	Water supply is not connected or is shut off. (Direct water hook-up models only)	Connect and/or open main water supply. Remove quick disconnect from back of unit. Depress insert quick disconnect plunger. If water does not come out, check water line for blockage.
	Water supply line is pinched. (Direct water hook-up models only)	Straighten water line.
	Water spray tube is clogged.	Remove spray tube and clean out See monthly maintenance on page 14.
	Water filters clogged.	Remove filter and clean. See special instructions.
	Loose electrical connection at water pump/solenoid valve.	Check continuity of wiring.
	Defective water pump/solenoid valve.	If power is going to the pump/solenoid and it does not work, then replace the pump/solenoid.
	Defective momentary switch.	If there is power to the momentary switch but not coming out when the red button is pushed in, then replace momentary switch.

PROBLEM	PROBABLE CAUSE	SOLUTION
Water from spray tube is reduced compared to former operation.	Spray tube is "clogged."	Clean spray tube. See monthly maintenance page 14.
	Water pump diode is defective.	Test diode for proper operation. If defective, replace. See special instructions Section IV-G.
Unit steams continually or becomes flooded.	Insufficient pre-heat	Remove excess water from generator casting. Allow 20 minutes before operating steamer. Do not operate steamer during pre-heat period.
	Clogged or punctured check valve in water pump. (Self-contained models)	Clean or replace check valve. See diagram on page 14. Section V
	Thermostat setting too low.	Surface temperature of casting should be between 350° F-375° F (177° C-191° C). If too low, replace the thermostat.
	Defective solenoid valve/water pump.	If power is going to pump/solenoid and it does not work, then replace the pump/solenoid.
	Defective water pump. (Self-contained models only)	Inspect check valve. If check valve is good and water flows continuously with or without timer cycle set replace pump.
	Defective solenoid. (Direct water hook-up models only)	If water flows continuously with or without timer cycle set replace solenoid.
	FWF Series only: Continuous steam switch on.	If timer cycle is not set but unit steams approximately every 20 seconds the continuous steam switch is on.
Self-Contained Units Only		
Water leaking in electrical housing	Water pump impeller is cracked.	Replace water pump impeller.
Timer models only		
Unit heats up, pump or solenoid valve works with momentary but will not steam during timer cycles	If READY light cycles on and off, pulse timer is defective.	Replace pulse timer.
	If READY light does not work but unit steams approximately every 20 seconds READY light is defective.	Replace READY light.
	If READY light does not work and unit does not steam approximately every 20 seconds main timer is defective.	Replace main timer.

GENERAL SERVICE INFORMATION

It is suggested that when any Roundup Steam Food Warmer/ Cooker requires repair that service be performed by a qualified service person and servicing of major assemblies be done at authorized service centers. When attempting to repair, turn the power switch off and allow the unit to cool. Unplug the electrical cord. Please use the "exploded view" parts picture for proper identification of replacement parts and as an aid in re-assembling the unit.

MAINTENANCE:

Daily —When the steamer is cool, remove the food pan and clean it with soap and water. Clean the exterior with stainless steel cleaner.

Monthly — Unplug unit and, when the steamer is cool, remove the perforated pan with trivet and the diffuser pan. Examine the generator for mineral deposits that may have formed at the bottom of the generator. Frequency of cleaning is determined by water conditions, usage and water filter system.

Use a scraper or a wire brush to clean out the generator. If deposits are excessive, a DeLimer or white vinegar solution may be necessary. NOTE: Two packets of DeLimer are included with your new unit. Additional packets are available from your Authorized Service Center. Specify DeLimer part No. 2140122.

Mix one packet of DeLimer into one pint of hot water and pour onto the generator surface. Allow it to soak for one (1) hour or more, depending on the build up of deposits. White vinegar can be used as a substitute for DeLimer. Remove the spray tube, lift loose end of the spray tube up and pull out of generator. Wash and rinse spray tube to remove DeLimer.

Empty the generator of the DeLimer solution. Clean the generator with hot, damp cloth. Reinstall spray tube. Plug unit in and turn power switch ON. Allow 20 minutes for preheat.

Models with timers; Start a 5 minute time cycle to purge and remaining DeLimer or vinegar.

Models without timers; Operate the black momentary switch approximately 15 times in intervals of 20 seconds.

Read "Special Instructions, Section I." Reinstall diffuser and perforated pan with trivet.

SPECIAL INSTRUCTIONS

SECTION I

STEAM GENERATOR: Roundup counter-top steamers use an open steam generator. To insure proper steaming characteristics, some mineral deposits must be present on the generator casting. If, during cleaning, the casting does become free of mineral deposits, the minerals from your water supply will re-form on the generator casting. Depending on water conditions, it will take approximately two days of operation to complete this process. To speed up this process, cover the steam generator surface with 1" to 2" of tap water and allow the water to boil away.

SECTION II

THERMOSTAT: The thermostat is pre-set at the factory to operate between 350° F and 375° F (177° C 191° C). To check this, remove the perforated pan and the diffuser pan. Turn unit on. DO NOT TOUCH THE GENERATOR. Allow 1-2 hours for proper temperature evaluation. Using a grill pyrometer, check three locations on generator base on each side of the water spray tube. If a majority of the measurements exceed 375° F (191° C) or are below 350° F (177° C), replace thermostat.

SECTION III

REMOVING ACCESS COVER: All electrical components are found in the side cabinet under the access cover (Item 24). To remove the access cover, unscrew the five outside screws.

CAUTION: On self-contained models, attempt to remove water from the water tank before removing access cover. Remove the silicone tubing from the elbow shaped water exit pipe.

NOTE: On self-contained models, DO NOT remove the four inner screws. These screws form an inner seal that secures the water tank to the access cover. If seal is broken, remove old seal and re-seal with Dow-Corning liquid rubber silicone No. 732.

SECTION IV

WATER FILTERS: To prevent solid matter from entering the steamer, filters are placed in the water systems. Occasionally these filters get clogged and prevent water from entering the generator. An easy cleaning of these filters will repair the unit.

Self-contained steamers contain two filters. Water tank filter (Item 27) is located directly in the water tank. Stand the filter so that it is located in the water exit hole. The water line filter (Item 26) is located in the elbow shaped water exit pipe.

Direct water hook-up models contain one filter (Item 30). It is found in the inlet hose assembly between two "worm clamps."

To clean any of the above filters, remove the filter, rinse under a running faucet and return the filter to its original location.

SECTION V

WATER PUMP COMPONENTS: Occasionally a component may fail on the water pump. The component only may be replaced, saving the customer the cost of a complete water pump. Consult trouble-shooting guide to determine if this is the case.

- A. Rubber check valve: Remove access cover (see special instructions sect. III). At water exit side of water pump, locate and remove two philips screws. Remove defective check valve and install new check valve.
- B. Rubber impeller: Remove access cover (see special instructions sect. III). Remove two screws securing water pump (Item 29) from base plate (Item 18). Remove silicone tubing hose clamps (Item K). Remove four philips screws and white plastic moldings from water pump. Remove nut from underside of water pump. Remove spring from water pump. Remove impeller (item 32) from water pump housing. Install spring on replacement impeller. Push impeller through water pump housing and rewind spring on base. Fit impeller securely into original position. Replace check valve and white plastic moldings. Replace nut. Reconnect the silicone tubing. Connect electrically and ground water pump to base plate.

Turn steamer on and test for leaks.

SECTION VI: REPLACING ELECTRICAL COMPONENTS

Below are instructions on replacing the major electrical components in the Roundup Steam Food Warmer/Cooker. To locate any electrical component, remove the access cover (see Special Instructions, Section III). The number next to the component's name refers to the item number found on the exploded view.

- A. (No. 3) Thermostat:** Remove the two screws holding thermostat in place. Pull the capillary tube from the casting. Push replacement thermostat's capillary tube into casting as far as possible. CAUTION: DO NOT "KINK" THE CAPILLARY TUBE! IF TUBE IS "KINKED", REPLACE. Using the schematic drawing, connect the electrical wires and fasten thermostat in place.
- B. (No. 25) Solenoid Valve Kit:** With a 1/2" wrench (5/8" wrench on models built after January 1980) remove compression nuts from solenoid and slide them down stainless steel tubing. Using the schematic drawing, connect the electrical wires and fasten new solenoid valve in place. Replacement compression nuts and sleeve are included, if needed.
- C. (No. 19) Main Timer:** On dial found on outside of unit, remove set screw with 1/16" allen wrench. Pull dial off unit. NOTE: ORANGE BUTTON WILL COME OFF WITH DIAL. Remove two screws found under dial. Remove access cover and replace main timer. Using the schematic drawing, connect the electrical

wires and fasten main timer in place. Re-fasten the dial and orange button.

- D. (No. 7) Handle Kit:** Remove side chrome caps, slide the black plate from the chrome holder. Notice and remove screws found in chrome holder. Put new handle in place using black spacers for proper location. Re-fasten screws, slide black plate in chrome holder and press side caps in place.
- E. (No. 26) Generator Tube Kit:** Remove compression nut from solenoid valve and male connector (found in casting). Replace with components found in new generator tube kit. On older models, if male connector must be replaced, removal of base plate is required.
- F. (No. 28) Quick Disconnect:** Remove compression nut and slide back on stainless steel tube. While holding nut on inside of unit, turn outside nut. Use the lock washer when replacing the quick disconnect. Replacement compression nut and sleeve are included, if needed.
- G. (No. 31) Water Pump Diode:** To determine if diode needs replacing, slice shrink tube on black wire of pump, and, with jumper wire, by-pass diode. If water pump operates replace diode to obtain maximum water pump efficiency. Remove and replace diode. Wrap new diode with electrical tape.

WARRANTY

Roundup Steam Food Warmers/Cookers are constructed of the finest materials available and manufactured under the highest quality standards. It is warranted to be free of mechanical and electrical defects for a period of one year. To insure proper installation, check electrical voltage prior to plugging unit into electrical circuit.

SEVERE DAMAGE WILL OCCUR IF STEAMER IS PLUGGED INTO AN IMPROPER CIRCUIT.

To insure proper continued operation of the unit, be sure to follow the maintenance procedures outlined in this manual.

Damage caused by neglect, abuse or careless handling will void this warranty. Because of its compact size and portability, charges for travel time and mileage cannot be included in warranty repair payment.

No equipment may be returned without an authorized return number. Returned merchandise is subject to a restocking charge, plus charges for any necessary repairs to place equipment in resaleable condition. Returned goods must be shipped prepaid to the factory.

All Roundup Steam Food Cookers are supplied with an automatic cycle timer. This device delivers a precise shot of steam every 20 seconds for the length of the cycle. Enclosed is a cooking guide compiled by Nancy Snider, an independent food consultant and home economist.

Ms. Snider used a Model FW-215 Roundup Steam Food Cooker to formulate her cooking times. Larger capacity Roundup

Steam Food Cookers may result in longer or shorter cooking times, depending on the product and the amount of food to be cooked.

Stir the foods about halfway through the cooking or heating cycle for even heating.

Starting temperature of food will affect cooking time.

EGGS	Minutes
Egg Slices, 6 Frozen (2 Oz. Ea.)	4
Soft Boiled, 8 (In Shell)	6
Hard Boiled, 8 (In Shell)	15
Omelets, 6 Frozen (3-½ Oz. Ea.)	8-12
Poached, 8	3
Scrambled, 1 Qt.	5

CEREALS	Minutes
Farina, quick (¾ cup dry cereal with 1 qt. hot water)	5
Grits, instant (1 lb. dry cereal with 1½ qt. hot water)	3
Grits, quick (1 lb. dry cereal with 2 qt. hot water)	10
Oatmeal (2 qt. cooked, 1 cup water optional)	6

BREADS	Minutes
Bagels, 4 (3 Oz. Ea.)	3
Cloverleaf Rolls, 6 (1 Oz. Ea.) shot of steam wait	20-30 seconds
Dinner Rolls, 6 (1 Oz. Ea.) shot of steam wait	20-30 seconds
Hamburger Buns, 4 (2-½ Oz. Ea.) shot of steam wait	20-30 seconds
Hot Dog Buns, 5 (2 Oz. Ea.) shot of steam wait	20-30 seconds
Hard Rolls, 4 (1-½ Oz. Ea.)	2
Hoagie Buns, 3 (2 Oz. Ea.)	2
Italian Bread, 3 (2-½ Oz. Ea.) shot of steam wait	20-30 seconds
Kaiser Rolls, 4 (2-½ Oz. Ea.)	1½
Onion Buns, 4 (2 Oz. Ea.) shot of steam wait	20-30 seconds

BREADS	Minutes
Tamale, 7 (3 Oz. Ea.)	5
Tamale, 7 Frozen (3 Oz. Ea.)	10
Tortilla, corn	shot of steam wait 20-30 seconds
Tortilla, flour	shot of steam wait 20-30 seconds

SEAFOOD	Minutes
Alaskan King Crab Legs (1 lb.)	4-5
Clams, 6 (to open)	shot of steam
Red Snapper, 4 (6 Oz. Ea. Fillets)	5-7
Rock Lobster Tails, 5 (8 Oz. Ea.)	8
Rock Lobster Tails, 5 Frozen (8 Oz. Ea.)	16*
Rock Lobster Tails, 4 (10 Oz. Ea.)	10
Rock Lobster Tails, 4 Frozen (10 Oz. Ea.)	20*
Sea Scallops, 1 Lb.	5-8
Shrimp, Green Headless, 20 (1 Oz. Ea.)	6
Shrimp, Peeled, Deveined, 1 Lb.	5-6
Shrimp, Peeled, Deveined, 1 Lb. Frozen	8-9
Turbot Steaks, 3 (8 Oz. Ea.)	5

MEAT	Minutes
Bratwurst, 6 (4 Oz. Ea.)	10
Frankfurters, 10 (1.6 Oz. Ea.)	3
Frankfurters, 8 (2 Oz. Ea.)	4
Frankfurters, 6 (2.7 Oz. Ea.)	5
Ham Steak, 4 Cooked, Frozen (4 Oz. Ea.)	4-5
Hamburgers, 4 Cooked, Frozen (4 Oz. Ea.)	7
Hamburgers, 4 Raw, Frozen (4 Oz. Ea.)	10-11
Ribs, 4 Cooked (5 Oz. Ea.)	10
Sausage, 16 link, cooked (1 Oz. Ea.)	8-10

POULTRY	Minutes
Chicken, 4 Quarter, (10 Oz. Ea.)	23-25*
Chicken, 2 Half (1-½ Lb. Ea.)	25*
Chicken Supreme, 6 Frozen, Pillow Pack (4 Oz. Ea.)	30*
Chicken or Turkey Roll, 2 Lb. ½ In. Cubes, IQF	7
Rock Cornish Game Hens, 2 Whole (26 Oz. Ea.)	25*
Rock Cornish Game Hens, 4 Half (13 Oz. Ea.)	15*

NOODLES AND RICE	Minutes
Macaroni, small elbow or shell (2 qt. cooked, 1 pt. water, 2 oz. oil)	5
Egg Noodles (2 qt. cooked, 1 pt. water, 2 oz. oil)	6-7
Rice, converted or regular (1 lb. with 1 qt. hot water)	20*
Rice, brown (1 lb. with 1½ qt. water)	45*
Spaghetti (2 qt. cooked, 1 pt. water, 2 oz. oil)	5
Spaetzle (2 qt. cooked, 1 pt. water, 2 oz. oil)	3-5

VEGETABLES	Minutes
Artichokes, 4 Whole (5 Oz. Ea.)	20-22*
Asparagus, spears (1 lb.)	11-14
Asparagus, spears, medium, frozen (2½ lb.)	15-17*
Broccoli, cuts (1 lb.)	12-14
Broccoli, cuts, frozen (1½ lb.)	13-14
Broccoli, spears (1 lb.)	15-20*
Broccoli, spears, frozen (2 lb.)	17-18*

VEGETABLES	Minutes
Brussel Sprouts, frozen (1¼ b.)	13-14
Cabbage, 6 3 In. Wedge (4 Oz. Ea.)	15
Carrots, sliced (1 lb.)	12
Carrots, whole baby, frozen (2 lb.)	15-20*
Cauliflower, whole (1 lb.)	13-20*
Cauliflower, florettes, frozen (2 lb.)	14-18*
Corn, whole kernel, frozen (1¼ lb.)	4
Green Beans, whole (1 lb.)	15-17*
Green Beans, whole frozen (1½ lb.)	13-14
Green Beans, cut frozen (1¼ lb.)	10
Greens, chopped, frozen (1 lb.)	40-45*
Lima Beans, frozen (1¼ lb.)	12-15
Okra, whole, frozen (1 lb.)	10-15
Parsnips, sliced (1 lb.)	8-10
Peas, frozen (1½ lb.)	8
Potatoes, 8 Whole (3 Oz. Ea.)	25*
Potatoes, mashed (2 qt.)	8
Spinach, chopped, frozen (3 lbs.)	25*
Squash, Acorn, 4 (8 Oz. Pcs.)	15-20*
Squash, winter, puree, frozen (1½ lb.)	12-15
Squash, zucchini, sliced, frozen (1¼ lb.)	10
Vegetables for New England Dinner for two, (2 2-3 oz. onions, 2 4 oz. cabbage wedges, 4 2-3 oz. potatoes, 4 carrots split lengthwise)	25*

*60 minute timer suggested.



1045 W. National Avenue

Addison, Illinois 60101 • 708-543-8650
FAX # 708-543-0359 • Telex # 28-5348