

Place this manual in the Small Equipment/  
Miscellaneous section of your Equipment Manual.

**Manufactured exclusively for  
McDONALD'S®**

**BY  
ANTUNES  
180 KEHOE BLVD.  
CAROL STREAM, ILLINOIS 60188, U.S.A.  
PHONE: 1-630-784-1000  
TOLL FREE: 1-877-392-7854  
FAX: 1-630-784-1650  
www.antunes.com**



MES-1200

Scan with mobile device or enter URL  
for product and service information.

<http://tiny.cc/ajaMES1200>



## TABLE OF CONTENTS

General.....	2	Preparing Unit.....	7
Warranty Information.....	2	Egg Cooking Procedure.....	7
Service/Technical Assistance.....	2	Cooking Meat Products.....	8
<b>Important Safety Information.....</b>	<b>3</b>	Bacon Timer.....	8
<b>Specifications.....</b>	<b>5</b>	<b>Maintenance.....</b>	<b>9</b>
Electrical Ratings.....	5	Daily Cleaning.....	9
Dimensions.....	5	Checking Grill Surface Temperature.....	9
Electrical Cord & Plug Configurations.....	5	<b>Troubleshooting.....</b>	<b>10</b>
Universal Top Cover and Egg Rack.....	6	<b>Replacement Parts.....</b>	<b>11</b>
<b>Installation.....</b>	<b>6</b>	<b>Wiring Diagram.....</b>	<b>12</b>
Unpacking.....	6	<b>NOTES.....</b>	<b>13</b>
Leveling the Unit.....	6	<b>Limited Warranty.....</b>	<b>Back Cover</b>
<b>Operation.....</b>	<b>7</b>		

### IMPORTANT

The unit must be level before use. Before using the unit, adjust the legs of the unit as needed and use a level (if available) to ensure the unit is level. If a level is not available, pour a small amount of water directly onto the center of the cool grill surface. If the unit is level, the water should pool in the middle and not drain toward a certain section of the unit. Make adjustments as required. Turn legs clockwise to shorten or counter-clockwise to lengthen. See image (Side view of unit).

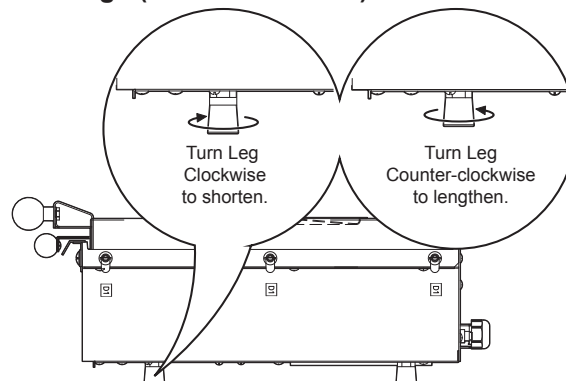

This manual is for the exclusive use of licensees and employees of McDonald's Systems, Inc.. © McDonald's Corporation All Rights Reserved

# MANUAL EGG COOKER/STEAMER

## OWNER INFORMATION

### General

The MES-1200 cooks/steams a maximum of twelve eggs (refrigerated) or twelve folded eggs (frozen) in approximately 150 seconds. Eggs within Egg Rings are cooked with a combination of heat and steam. With the cover closed, water is poured into a trough on the cover and drips onto a hot Platen producing steam, cooking the eggs and heating the Canadian Bacon for the "Egg McMuffin Sandwich".

The unit is equipped with audio-visual signals for operation.

This manual provides the safety, installation, and operating procedures. We recommend that all information contained in this manual be read prior to installing and operating the unit.

Your MES-1200 is manufactured from the finest materials available, assembled to Roundup's strict quality standards, and tested at the factory to ensure dependable trouble-free operation.

### Warranty Information

**Please read the full text of the Limited Warranty printed on the front cover of this manual.**

**If the unit arrives damaged, contact the carrier immediately and file a damage claim with them. Save all packing materials when filing a claim. Freight damage claims are the responsibility of the purchaser and NOT covered under warranty.**

The warranty does NOT extend to:

- Damages caused in shipment or damage as result of improper use.
- Installation of electrical service.
- Installation, calibration, or adjustment.
- Normal maintenance outlined in this manual.
- Consumable parts such as Egg Rings, gaskets, rubber feet, labels, O-rings, light bulbs, etc.
- Malfunction resulting from improper service or maintenance.
- Damage caused by improper installation, abuse, or careless handling.

- Damage from moisture getting into electrical components.
- Damage from tampering with, removal of, or changing any preset control or safety device.
- Damage caused by parts or components not provided by A.J. Antunes & Co.

### Service/Technical Assistance

If you experience any problems with the installation or operation of your unit, contact Antunes Technical Service.

Fill in the information below and have it handy when calling your Authorized Service Agency for assistance. The serial number is on the specification plate located on the side of the unit.

Purchased From: \_\_\_\_\_

Date of Purchase: \_\_\_\_\_

Model No.: \_\_\_\_\_

Serial No.: \_\_\_\_\_

Mfg. No.: \_\_\_\_\_

Use only genuine Antunes replacement parts in this unit. Use of replacement parts other than those supplied by the manufacturer will void the warranty.

**IMPORTANT! Keep these instructions for future reference. If the unit changes ownership, be sure this manual accompanies the equipment.**

## IMPORTANT SAFETY INFORMATION

In addition to the warnings and cautions in this manual, use the following guidelines for safe operation of the unit.

- Read all instructions before using equipment.
- Install or locate the equipment only for its intended use as described in this manual.
- Do NOT use corrosive chemicals in this equipment.
- Do NOT operate this equipment if it has a damaged cord or plug; if it is not working properly; or if it has been damaged or dropped.
- This equipment should be serviced by qualified personnel only. Contact the nearest Authorized Service Agency for adjustment or repair.
- Do NOT block or cover any openings on the unit.
- Do NOT immerse cord or plug in water.
- Keep cord away from heated surfaces.
- Do NOT allow cord to hang over edge of table or counter.

The following warnings and cautions appear throughout this manual and should be carefully observed.

- Turn the power off, unplug the power cord, and allow the unit to cool down before performing any service or maintenance.
- The procedures in this chapter may include the use of chemical products. These chemical products will be highlighted with bold face letters followed by the abbreviated HCS (Hazard Communication Standard). See your Hazard Communication Standard manual for the appropriate Material Safety Data Sheets (MSDS).
- The equipment should be grounded according to local electrical codes to prevent the possibility of electrical shock. This requires a grounded receptacle with separate electrical lines to be protected by fuse(s) or circuit breaker(s) of the proper rating.
- All electrical service connections must be in accordance with local and/or other applicable electrical codes.

## IMPORTANT

**A.J. Antunes & Co. reserves the right to change specifications and product design without notice. Such revisions do NOT entitle the buyer to corresponding changes, improvements, additions, or replacements for previously purchased equipment.**

## IMPORTANT SAFETY INFORMATION (continued)

- Do NOT clean this appliance with a water jet.
- Do NOT use a sanitizing solution or abrasive materials. The use of these may cause damage to the stainless steel finish.
- Chlorides or phosphates in cleaning agents (e.g. bleach, sanitizers, degreasers, or detergents) could cause permanent damage to stainless steel equipment. The damage is usually in the form of discoloration, dulling of metal surface finish, pits, voids, holes, or cracks. This damage is permanent and not covered by warranty.

The following tips are recommended for maintenance of your stainless steel equipment.

- Always use soft, damp cloth for cleaning, rinse with clear water and wipe dry. When required, always rub in direction of metal polish lines.
- Finger marks and smears should be rubbed off using soap and water.
- Hard water spots should be removed using a vinegar solution.

### WARNING

#### ELECTRICAL SHOCK HAZARD.

FAILURE TO FOLLOW THE INSTRUCTIONS IN THIS MANUAL COULD RESULT IN SERIOUS INJURY OR DEATH.

- Electrical ground is required on this appliance.
- Do NOT modify the power supply cord plug. If it does not fit the outlet, have a proper outlet installed by a qualified electrician.
- Do NOT use an extension cord with this appliance.
- The unit should be grounded according to local electrical codes to prevent the possibility of electrical shock. It requires a grounded receptacle with separate electrical lines, protected by fuses or circuit breaker of the proper rating.
- Check with a qualified electrician if you are unsure if the appliance is properly grounded.

### CAUTION

All electrical connections must be in accordance with local electrical codes and any other applicable codes.

## SPECIFICATIONS

### Electrical Ratings

Model & Mfg. No.	Volts	Watts	Amp	Hertz
MES-1200 9300610	230	2900	12.6	50/60
MES-1200 9300612	230	2900	12.6	50/60
MES-1200 9300614	230	2900	12.6	50/60
MES-1200 9300616	230	2900	12.6	50/60
MES-1200 9300619	230	2900	12.6	50/60
MES-1200 9300620	230	2900	12.6	50/60



### Shipping Weight

- MES-1200: 50 lbs (22.6 kg)

### Net Weight

- MES-1200: 43 lbs (19.5 kg)

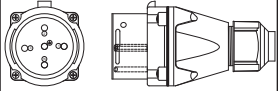
### Electrical Cord & Plug Configurations

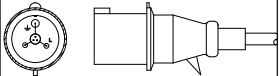
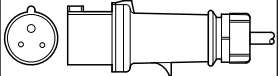
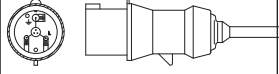
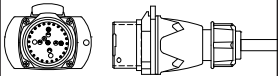
Model & Mfg. No.	Description	Configuration
MES-1200 9300616	Marechal, Pin & Sleeve, 32 Amp, 250 VAC (Australia) (Assembly Only)	
MES-1200 9300614	CEE 7/7, 16 Amp., 250 VAC (Assembly Only)	
MES-1200 9300610	IEC-309, 16 Amp., 250 VAC., Pin & Sleeve (Assembly Only)	
MES-1200 9300612	IEC-309 230 VAC Non-Molded Plug (China Only)	
MES-1200 9300619	IEC-309 32 Amp., 230 VAC, 3 Pin (Malaysia Only)	
MES-1200 9300620	Marechal, Pin & Sleeve, 32 Amp., 250 VAC (New Zealand)	

### Dimensions

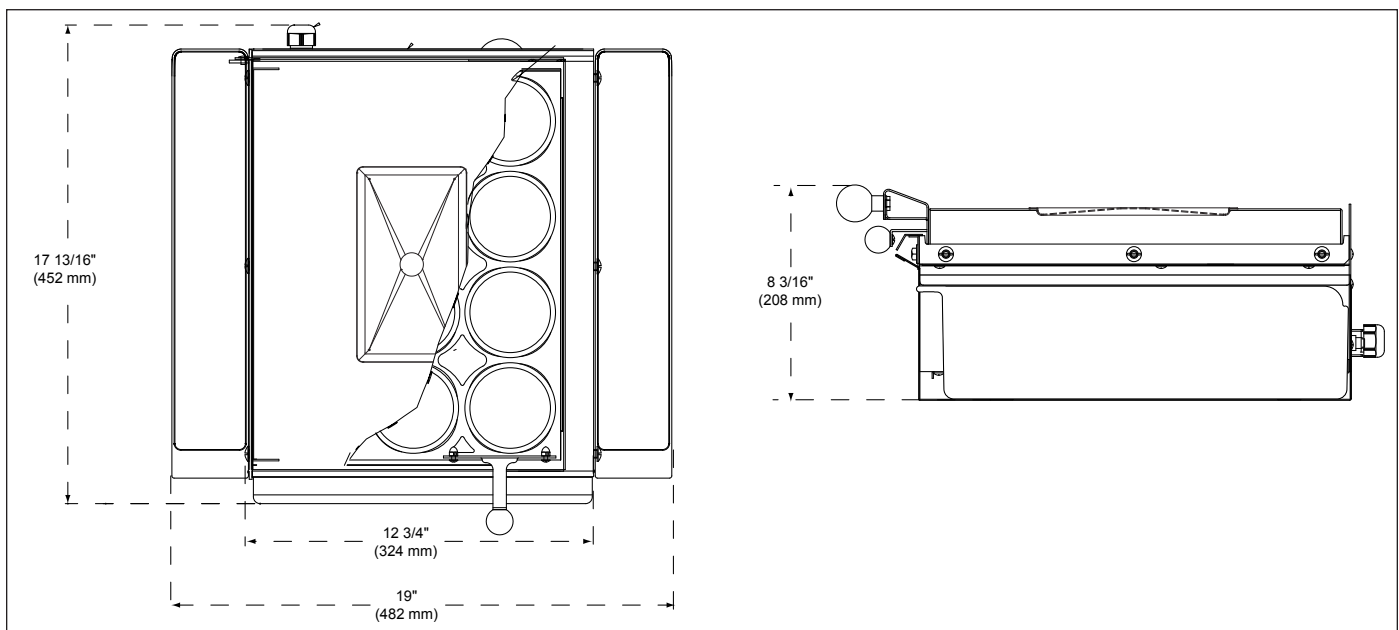

## INSTALLATION

### Unpacking

1. Remove unit and all packing materials from shipping carton.

**NOTE: If any parts are missing or damaged, contact A.J. Antunes & Co. IMMEDIATELY at 1-877-392-7854 or 630-784-1000.**

2. Remove information packet.
3. Remove all packing materials and protective coverings from the unit.
4. Wipe all surfaces of the unit with a hot damp cloth.

**NOTE: Do NOT use a dripping wet cloth. Wring it out before use.**

5. Clean the Egg Rings, Egg Rack, Top Cover, and Scrap Pans in hot, soapy water. Rinse in clear water and allow to air dry.
6. Reassemble the unit.

### Leveling the Unit

The MES-1200 must be placed on a level surface. The unit comes with 4 individually adjustable legs to assist in leveling. Be sure to place the unit on a sturdy flat surface and adjust the legs as needed to ensure the unit is level. Turn legs **clockwise to shorten** or **counter-clockwise to lengthen**.

To verify if the unit is level, use a level (if available). If a level is not available, open the Top Cover and Egg Rack and pour a small amount of water directly onto the cool grill surface. If the unit is level, the water should pool in the middle and not drain toward a certain section of the unit. Make adjustments as required.

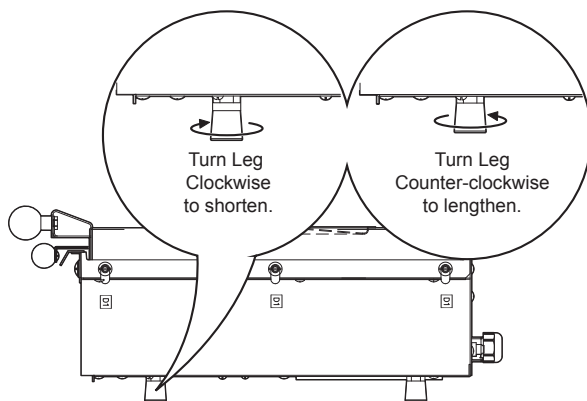

**▲ IMPORTANT ▲**

Failure to level the unit may result in unevenly cooked product.

### Universal Top Cover and Egg Rack

The MES-1200 is designed with a Universal Top Cover and Egg Rack that can lift open from either the left- or right-hand side depending on restaurant setup. The Universal Top Cover is pre-assembled at the factory with the handle on the right side of the assembly.

To rotate the Top Cover and Egg Rack, refer to Figures 1, 2, and 3.

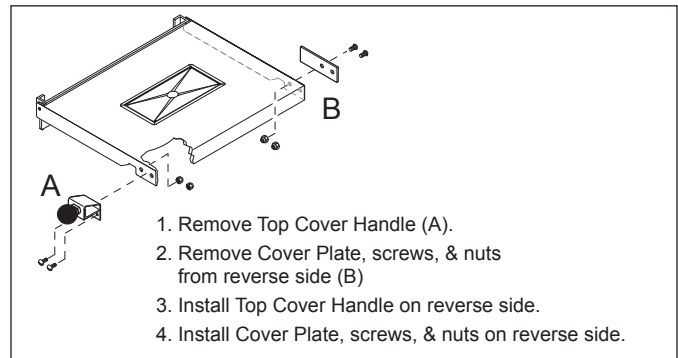

**Figure 1. Rotating Top Cover Handle**

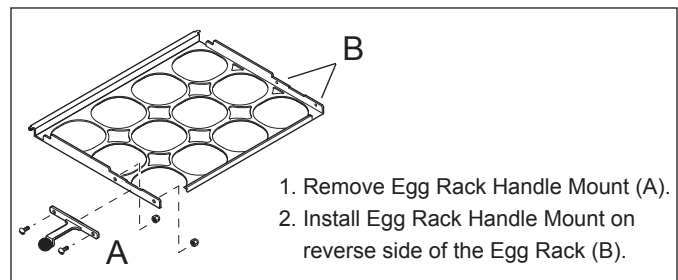

**Figure 2. Rotating Egg Rack Handle**

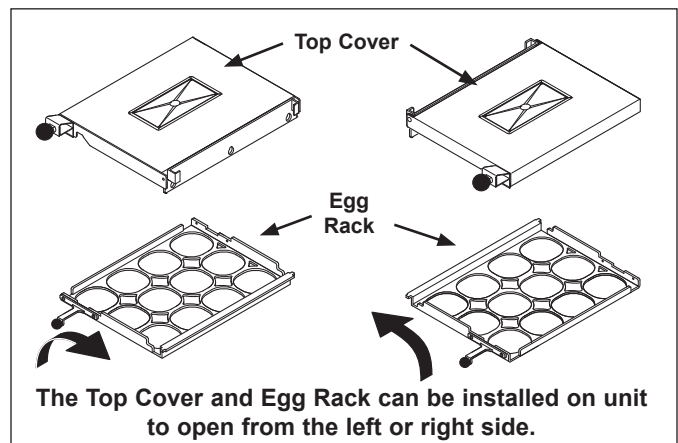

**Figure 3. Rotating Top Cover and Egg Rack**

## OPERATION

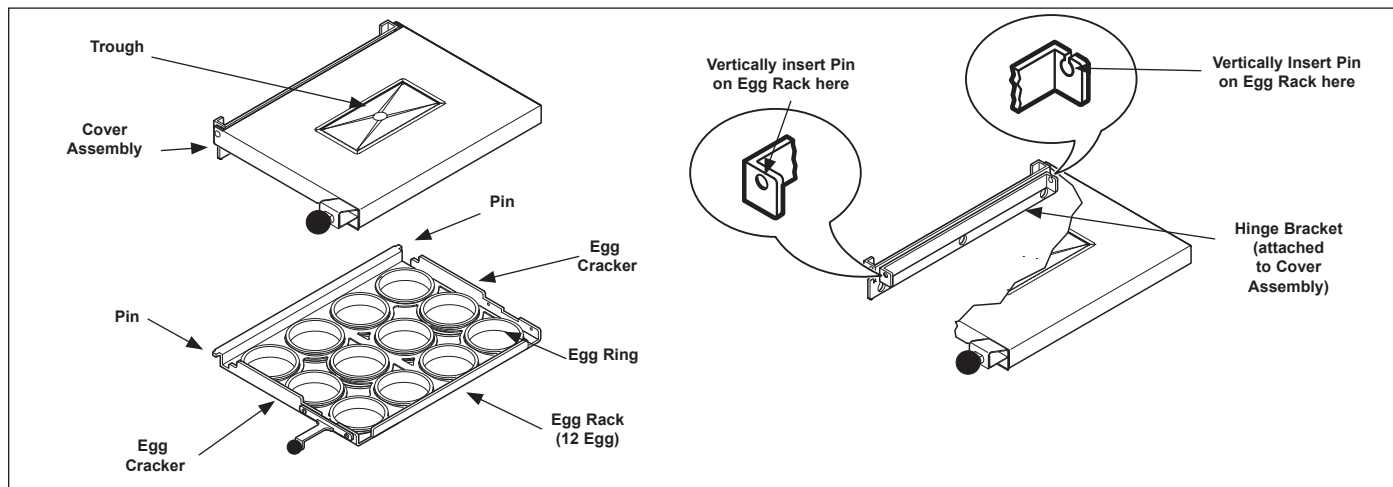

Figure 4. Cover Assembly & Rack Assembly

### Preparing Unit

1. Turn the power on (Figure 6).
2. Place Egg Rings into Egg Rack (Figure 4).
3. Vertically place the pins of the Egg Rack into the slots on the Hinge Bracket.
4. Check to see that all Egg Rings are seated flat on the Grill Surface.
5. Ensure that the Egg Rack and Top Cover are in the down position while the unit warms up.
6. Slide the Scrap Pans into place on both sides of the unit.
7. Allow the unit to preheat for approximately 20-30 minutes.

**NOTE:** The Ready Indicator Light will flash while the unit is heating up and will stay on after the unit reaches operating temperature.

### Egg Cooking Procedure

1. Ensure that the unit is set on a level surface.
2. Verify that the unit itself is level so that water does not run from one side to the other. Adjust the legs as needed to level the unit. Refer to the section titled "Leveling the Unit" for more information.
3. Make sure the grill is clean and free of all extra butter, oils, or egg product. Use a brush to clean egg rings.

To ensure proper cooking, place eggs into rings in numerical order from 1 to 12 as shown below.

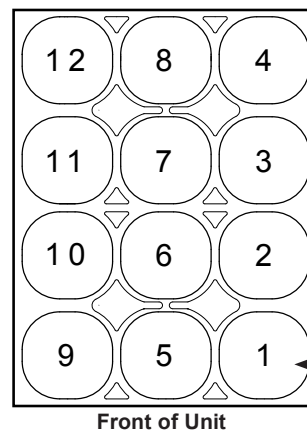

Figure 5. Egg Cooking Procedure

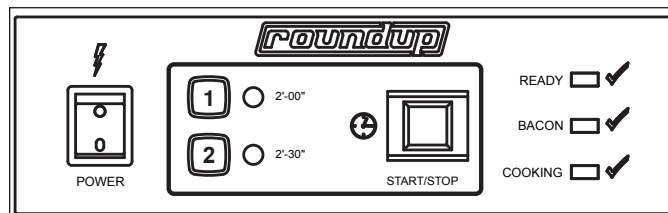

Figure 6. Operating Controls

4. Raise the Top Cover and spray grill spray on the egg rings (1 spray for every two rings).

**NOTE:** Grill spray should be applied approximately 6-8 inches above the grill.

5. Crack the eggs into the Egg Rings from Front to Back, right to Left as shown in Figure 5.

## OPERATION (continued)

6. Continue to crack the eggs, placing them in order, until all six Egg Rings (or 12 shown above) contain an egg.
7. Break the egg yolks with a Yolk Breaker.
8. Close the Top Cover.
9. Fill the trough on the Top Cover with no more than 3 ounces of warm water until it is **completely full**. This is very important to get a completely cooked egg with a jelled yolk. Using less water results in under cooked eggs.

**NOTE: Make sure the holes in the trough are not plugged!**

10. Press the **TIME 1** button for folded eggs or the **TIME 2** button for shelled eggs.
11. Press the **START/STOP** button to start the cooking cycle.

**NOTE: When possible, eggs should be pulled from the cooler and not kept at the grill. Tempering eggs increases their temperature. Egg kept past 30 minutes will result in a higher proportion of over-cooked eggs.**

**NOTE: The Cooking Indicator Light will light when the START/STOP button is pressed and released.**

12. When the Cooking Indicator Light turns off and the audio signal sounds, press the **START/STOP** button to turn off the audio signal.
13. Open the Top Cover and raise the Egg Rack about 1 inch (26 mm), then drop the rack to loosen the eggs.
14. Raise the Egg Rack completely off the eggs and remove the eggs starting with the **FIRST** egg added (Figure 5). Continue removing the eggs in the order they were added until all eggs have been removed.
15. Remove waste into the Scrap Pans. The preferred method is to use a plastic scraper. If you are using a metal scraper, wrap the scraper in a clean, dry towel to move waste into Scrap Pans.

**NOTE: Do NOT scrape the grill surface with a metal scraper. This can cause damage to the grill surface.**

15. Lower the Egg Rack and Top Cover. The unit is ready for further cooking.

## Cooking Meat Products

Follow this procedure to cook sliced Canadian bacon, ham, or other meat products.

### **WARNING**

**Be sure to wear heat-resistant gloves when removing the Egg Rack while the unit is on. Use extreme care to avoid personal injury.**

1. Wearing heat-resistant gloves, remove the Egg Rack and set it aside on a heat resistant surface.
2. When the Bacon Indicator Light begins to flash and the audio signal sounds, place the meat product on the Grill Surface and close the Top Cover.
3. The Bacon Indicator Light continues to flash until the end of the cooking cycle. When the Cooking Indicator Light turns off and the audio signal sounds, press the **START/STOP** button to turn off the audio signal.
4. Open the Top Cover and remove the meat product from the Grill Surface.

## Bacon Timer

If, during the standby mode, the Bacon Indicator Light is not on, this means that the Bacon Timer is disabled. To enable the Bacon Timer, with the unit turned on, press the **TIME 1** and **TIME 2** buttons simultaneously for 3 or more seconds. The Bacon Indicator Light will turn on. The Bacon Timer is now enabled.

To disable the Bacon Timer, press the **TIME 1** and **TIME 2** buttons simultaneously for 3 or more seconds. The Bacon Indicator Light will turn off. The Bacon Timer is now disabled.

If the Bacon Timer is enabled, an audio signal will sound for a few seconds and the Bacon Indicator Light will begin to flash 30 seconds before the end of the cooking cycle. During this time, the product should be placed on the front part of the grill so that it will heat for 30 seconds. The Bacon Indicator Light will continue to flash until the end of the cooking cycle.

## MAINTENANCE

### ⚠ WARNING ⚠

Turn the power off, unplug the power cord, and allow the unit to cool down before performing any service or maintenance.

### Daily Cleaning

1. Turn the power switch off. Unplug the power cord. Allow the unit to cool completely. Put on Heat-Resistant Gloves.

**NOTE: If the unit is hot, use Heat-Resistant Gloves.**

2. Remove the Top Cover, Egg Rings, and Scrap Pans from the unit. Take them to the three compartment sink.
3. Wash, rinse, and sanitize the Top Cover, Egg Rings, and Scrap Pans. Allow to air dry. Reinstall parts when complete.
4. Spray a clean, sanitizer soaked towel with McD All-Purpose Super Concentrate (APSC). Wipe the entire grill surface until it is clean. Use a separate clean, sanitizer-soaked towel to rinse the grill surface to remove all traces of APSC.

**NOTE: If a scraper is needed during cleaning, use a plastic scraper. This is the preferred method. If you are using a metal scraper, wrap the scraper in a clean grill cloth first.**

**NOTE: Do NOT Pour water onto the grill surface when it is hot. This can cause damage to the grill.**

5. Wipe down the exterior of the unit with a separate clean, sanitizer-soaked towel.
6. Plug in the power cord. Turn the power switch on. Return the unit to use.

### Checking Grill Surface Temperature

**NOTE: A pyrometer is required for this procedure.**

### ⚠ WARNING ⚠

This procedure exposes you to hot surfaces. Use extreme care when performing procedure to avoid personal injury.

1. Remove the Top Cover and the Egg Rack by lifting the whole assembly until clear of the base.
2. Turn the power on and allow 30 minutes for the unit to preheat.
3. Using a pyrometer, measure the temperature at the **middle** of the Grill Surface. The temperature should be 250°F–300°F (121°C–149°C).  
  
If temperature is within range, proceed to Step 4.  
  
If temperature is above or below range, call your Authorized Service Agency.
4. Turn the power off.
5. Reinstall the Egg Rack and Top Cover.

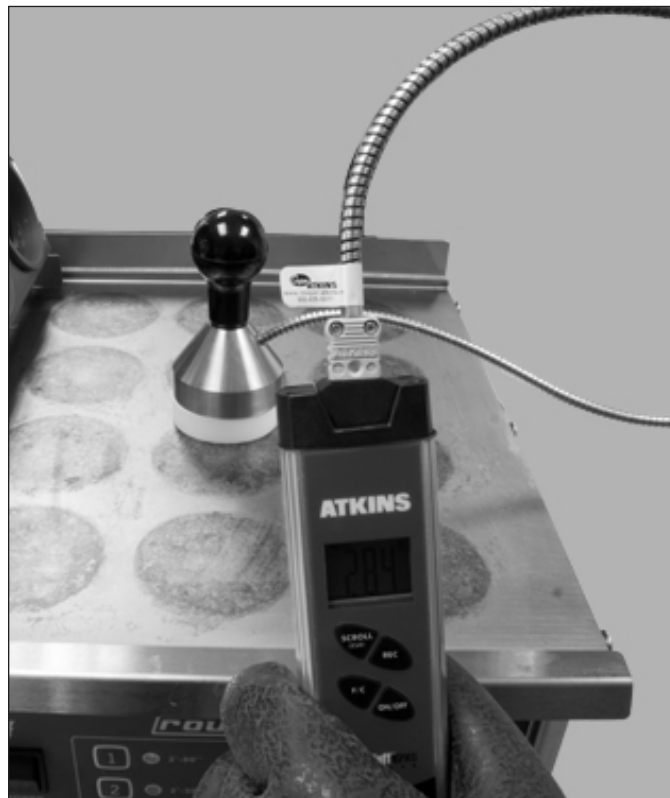

# MANUAL EGG COOKER/STEAMER

## TROUBLESHOOTING



To avoid possible personal injury and/or damage to the unit, inspection, test, and repair of electrical equipment should be performed by qualified service personnel. The unit should be unplugged when servicing.

Problem	Possible Cause	Corrective Action
Unit fails to operate and control panel lights fail to signal on.	No power/low power.	Make sure power is on and power cord is locked into place. Check main circuit breakers.
	Inoperable electrical outlet.	Plug into different outlet of same amperage rating.
	Inoperable power switch.	Contact your maintenance person or Authorized Service Agency.
	Inoperable power cord.	
	Loose connections.	
Unit fails to heat.	Loose connections.	Contact your maintenance person or Authorized Service Agency.
	Inoperable grill.	
	Low voltage.	
	Inoperable hi-limit thermostat.	
	Inoperable thermocouple.	
	Inoperable solid state relay.	
Eggs do not cook properly.	Using refrigerated eggs and <b>TIME 1</b> button selected.	Use <b>TIME 2</b> button when using refrigerated eggs.
	<b>TIME 2</b> button selected and eggs overcooked.	Use <b>TIME 1</b> button when using room temperature eggs.
	Incorrect amount of water added to trough in cover.	Fill trough in cover with water before starting time cycle.
	Grill temperature too low or high.	Contact your Authorized Service Agency.
	Loose connections.	Contact your Authorized Service Agency.
	Unit/table is not level.	Level the table and unit as necessary.
Eggs sticking to Grill Surface.	Dirty Grill Surface.	Clean Grill Surface.
	Insufficient butter being used.	See the Operating Instructions section.
Eggs sticking to Egg Rings.	Insufficient butter being used.	See the Operating Instructions section.
	Dirty Egg Rings.	Do NOT use an abrasive scrubbing pad to clean Egg Rings.
	Inoperable Egg Ring.	Replace Egg Ring.
Not signaling on "Bacon" or "Ready".	Inoperable indicator light or audio signal.	Contact your maintenance person or Authorized Service Agency.
	Inoperable control board.	
	Loose connection.	
	Bacon Timer is disabled.	Enable Bacon Timer according to the Operating section of this manual.

If the troubleshooting steps listed do not solve your problem, contact an A.J. Antunes Authorized Service Agency for further assistance.



# MANUAL EGG COOKER/STEAMER

## REPLACEMENT PARTS (continued)

Item	Part No.	Description	Qty.
1	0021327	Nose Piece Weldment	1
3	7000674	Grill Platen	1
4a	040P138*	Lock-nut, Conduit - 1/2" NPT	1
4b	040P355*	Lock-nut, Conduit - 1/2" Plastic (Mfg. No. 9300616 & 9300620 only)	1
5a	0400315	Strain Relief - Cord Connector	1
5b	0400354	Strain Relief 90 Degree (Mfg. No. 9300616 & 9300620 only)	1
7	2180259	Scrap Pan	2
11	0502900	Bracket, Sensor	1
12	7000675	Cover, Rack, & Ring Assembly (Incl. All Shown)	1
13	7000676	Cover, 12 Egg (Incl. #28, 48, 65, 74, 75, & 76)	1
14	7000677	Rack, 12 Egg Ring (Incl. #27, 45, 75, 76, & 78)	1
15	0021399	Panel, Base	1
16	0021325	Housing, Main	1
18	0504075	Cover, Insulation	2
19	0021326	Rear Panel Weldment	1
21	0504078	Bracket, Hi-Limit	1
24	0700587	Marechal, Pin & Sleeve, 32 Amp, 250 VAC (Mfg. No. 9300616)	1
	0700453	CEE 7/7, 16 Amp., 250 VAC (Mfg. No. 9300614)	1
	0700457	IEC-309, 16 Amp., 250 VAC., Pin & Sleeve (Mfg. No. 9300610)	1
	0700442	IEC-309 230 VAC Non-Molded Plug (Mfg. No. 9300612)	1
	0700588	IEC-309 32 Amp, 230 VAC, 3 Pin (Mfg. No. 9300619)	1
	0700699	Marechal, Pin & Sleeve, 32 Amp., 250 VAC (Mfg. No. 9300620)	1
25	1001425	Label, Control	1
26	210K122	Adj. Leg Kit (4 Pack)	1
27	2100137	Knob Ball	1
28	2100138	Knob-Ball	1
29	210K108	Rubber Tip Kit (4 Pack)	1
31	2130111	Egg Ring (Single)	12/6
	213K101	Egg Ring (Pack of 6)	1/2
33	300P102*	Nut, Speed #8-32 "U"	1
37	306P113*	Screw, Mach. #6-32 x 5/8" Sltrshd	2
38	306P123*	Screw, Mach. #6-32 x 7/8" Sltrshd	4
		#6-32 x 7/8" Sltrshd	2
39	306P130*	Nut, Hex KEPS #6-32	6
40	308P102*	Washer, Int. Tooth #8	1
41	308P104*	Screw, Mach #8-32 x 3/8" Sltrshd	1

Item	Part No.	Description	Qty.
42	308P143*	Nut, Hex KEPS #8-32	1
43	308P157*	Screw, Tap #8-32 x 3/8"	1
44	310P102*	Washer, Int Tooth-lock #10	2
45	310P109*	Screw, Mach #10-32 x 3/8" Sltrshd	1
46	310P136*	Screw, Mach. #10-32 x 1 and 1/4" Slpanhd	1
47	310P149*	Screw, Mach. #10-32 x 7/8" Slpanhd	1
48	325P101	Stud 1/4-20 x 1-1/2"	1
49	325P104*	Washer, Flat 1/4" S/S	1
50	325P109*	Screw, Hxcap 1/4-20 x 3/4"	1
51	4010137	Switch, Rocker (25A-250V)	1
52	4010187	Transformer, Stepdown (240V/12)	1
53	4010190	Switch, Momentary	1
54	4010242	PC-Board, Switch-Two Button	1
55	7000272	Thermostat, Hi-Limit	1
56	4050229	Line Filter	1
57	7000370	Solid State Relay	1
58	7000136	Terminal Block, 3-Pole	1
59	4070174	Egg Station LED Board	1
62	7000833	Control Board	1
63	7000391	A/C Line Isolator Board	1
64	0400337	Insulation	1
65	2120111	Spacer	1
66	4050214	Thermocouple	1
67	2180111	Plastic Dispensing Bottle (not shown)	1
69	0011251	Heat Sink Assembly	1
70	0700648	Wire Set, Main (not shown)	1
71	0700655	Wire Harness/PCB-LEDs (not shown)	1
72	0700656	Wire Harness/PCB-Isolator BD (not shown)	1
73	0700657	Wire Harness/PCB-2 Button Bd (not shown)	1
74	0021396	Cover Handle Weldment	1
75	3060103	Screw Mach #6-32 x 3/8" Sltrshd 304 S/S Brt.	4
76	3060152	Nut, Acorn #6-32 Low Crown w/ centerlock	4
78	0504562	Handle, Rack	1
79	2120180	Spacer .312 OD x .257 ID x .13 LG S/S	6
80	3250132	Screw, Mach 1/4-20 x 1/2"	6
81	0507135	Anti-Rotation Plate (Mfg. No. 9300616 & 9300620 only)	1
82	308P158	#8-32 x 5/8 Self Tapping Screw (Mfg. No. 9300616 & 9300620 only)	1

\* Available only packages of 10.

## WIRING DIAGRAM

**NOTE: ALL WIRES TO BE 14 GA. TFE-200°C  
UNLESS OTHERWISE SPECIFIED.**  
• # 18 GA. TFE-200°C  
• # 22 GA. TFE-200°C

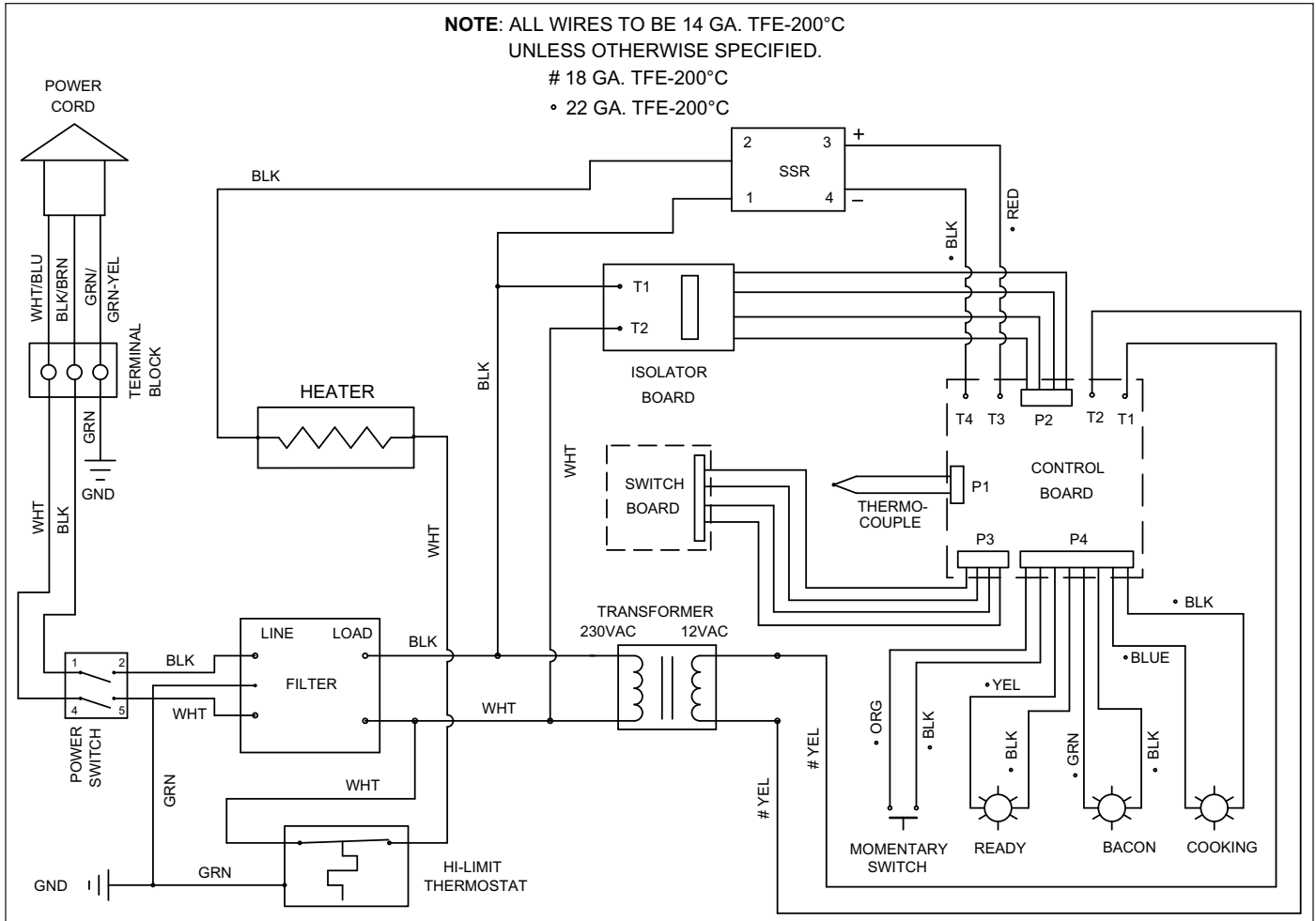





## LIMITED WARRANTY

The Antunes Food Service Equipment Division of A.J. Antunes & Co. provides the following limited warranty to the original purchaser of all McDonald's Equipment. All components are warranted against defects in the material and workmanship for a period of two (2) years from date of original installation.

If any part becomes defective during the period of this Warranty, Antunes Food Service will pay labor costs to an Authorized Service Agent to replace the part plus travel expenses.

### WARRANTY EXCLUSIONS

- The cost of installation.
- Equipment that has been damaged due to shipment. Purchaser should make damage claim directly upon carrier.
- Alteration, misuse, abuse.
- Improper storage or handling.
- Improper maintenance.
- Failure to follow proper installation instructions, including electrical connection.
- Improper or unauthorized repairs.
- Scheduled Maintenance procedures as outlined in your MRC Card.
- Consumables such as Grill Covers (Release Sheets), gaskets, Conveyor Belt Wraps, O-Rings, and light bulbs.
- Overtime or Holiday charges.
- Mileage over 50 miles/80 km (100 miles/160 km round-trip), or travel time over two (2) hours.
- Freight, foreign, excise, municipal, or other sales or use taxes.
- Consequential damages such as loss of profit, loss of time, the cost of repairing or replacing other property which is damaged, or any other incidental damage of any kind.

Antunes Food Service reserves the right to make changes in design or add improvements on any products. The right is always reserved to modify Equipment because of factors beyond our control and government regulation. Changes to Equipment do not constitute a warranty charge.

This warranty is exclusive and is in lieu of all other warranties, expressed or implied, including any implied warranty of merchantability or fitness for a particular purpose, each of which is expressly disclaimed. The remedies described above are exclusive, and in no event shall A.J. Antunes & Co. or any of its Divisions be liable for special consequential or incidental damages for the breach or delay in the performance of this warranty.



#### Corporate Headquarters

Carol Stream, Illinois  
Phone: +1 (630) 784-1000  
Toll Free: +1 (800) 253-2991  
Fax: +1 (630) 784-1650

#### China Facility

Suzhou, China  
Phone: +86-512-6841-3637  
Toll Free: +400-0-7878-22  
Fax: +86-512-6841-3907