

Manufacturing Numbers 9100320, 9100330, 9100332, 9100334, 9100336, 9100340, 9100342, 9100344, 9100346, & 9100348

Place this manual in the Steamer section of your **Equipment Manual**.

**Manufactured exclusively for
McDONALD'S®**
BY
A.J. ANTUNES & CO.
180 KEHOE BLVD.
CAROL STREAM, ILLINOIS 60188, U.S.A.
PHONE: 1-630-784-1000
TOLL FREE: 1-877-392-7854 (US Only)
FAX: 1-630-784-1655
www.ajantunes.com



TABLE OF CONTENTS

| | | | |
|---|----------|--|-----------|
| Owner Information | 2 | General | 8 |
| General | 2 | Programming | 10 |
| Warranty Information | 2 | Programming | 10 |
| Service/Technical Assistance | 2 | Maintenance | 12 |
| Important Safety Information | 3 | Maintenance Schedule | 12 |
| Electrical Ratings | 5 | Daily | 12 |
| Model Designation | 2 | Monthly | 12 |
| Specifications | 5 | Flushing/Cleaning Water Solenoid | 13 |
| Electrical Cord & Plug Configurations | 5 | Diagnostics | 14 |
| Dimensions | 5 | Troubleshooting | 16 |
| Installation | 6 | Replacement Parts | 18 |
| Unpacking | 6 | Optional Accessory | 20 |
| Equipment Setup | 6 | Wiring Diagram | 21 |
| Operation | 8 | Notes | 22 |

LIMITED WARRANTY

The Antunes Food Service Equipment Division of A.J. Antunes & Co. provides the following limited warranty to the original purchaser of all McDonald's Equipment. All components are warranted against Manufacturer's defects in the material and workmanship for a period of two (2) years from date of original installation not to exceed 30 months from the date of shipment from our factory.

If any part becomes defective during the period of this Warranty, Antunes Food Service will pay negotiated straight time labor costs to an Authorized Service Agent to replace the part, plus travel expenses up to 100 miles/160 km, 2 hours round trip.

WARRANTY EXCLUSIONS

- The cost of Installation.
- Equipment that has been damaged due to shipment. Purchaser should make damage claim directly upon carrier.
- Alteration, misuse, abuse.
- Improper storage or handling.
- Improper maintenance.
- Failure to follow proper Installation instructions, including electrical connection.
- Improper or unauthorized repairs.
- Scheduled Maintenance procedures as outlined in your MRC Card.
- This Warranty does not cover Consumable items.
- Water pressure problems or contamination problems such as foreign material in water lines or inside solenoid valves due to an incoming water source.
- Overtime or Holiday charges.
- Mileage over 100 miles/160 km round-trip, or travel time over two (2) hours.
- Freight, foreign, excise, municipal or other sales or use taxes.
- Consequential damages such as loss of profit, loss of time, the cost of repairing or replacing other property which is damaged, or any other incidental damage of any kind.

Antunes Food Service reserves the right to make changes in design or add improvements on any products. The right is always reserved to modify Equipment because of factors beyond our control and government regulation. Changes to Equipment do not constitute a warranty charge.

This warranty is exclusive and is in lieu of all other warranties, expressed or implied, including any implied warranty of merchantability or fitness for a particular purpose, each of which is expressly disclaimed. The remedies described above are exclusive, and in no event shall A.J. Antunes & Co. or any of its Divisions be liable for special consequential or incidental damages for the breach or delay in the performance of this warranty.

OWNER INFORMATION

General

The Multi-Purpose Steamer produces steam using ordinary tap water for quick heating of food items. Simple push-button action delivers a programmable "shot" of steam. Because the amount of steam is consistent, it removes the guesswork and produces a uniform finished product from one operator to the next.

This manual provides the safety, installation, operating, and basic troubleshooting procedures for the Multi-Purpose Steamer. We recommend that all information contained in this manual be read prior to installing and operating the unit.

Your Multi-Purpose Steamer is manufactured from the finest materials available, assembled to Roundup's strict quality standards and tested at the factory to ensure dependable trouble-free operation.

Warranty Information

Please read the full text of the Limited Warranty in this manual.

If the unit arrives damaged, contact the carrier immediately and file a damage claim with them. Save all packing materials when filing a claim. Freight damage claims are the responsibility of the purchaser and are NOT covered under warranty.

The warranty **does not extend to:**

- Damages caused in shipment or damage as a result of improper use.
- Installation of electrical service.
- Normal maintenance as outlined in this manual.
- Malfunction resulting from improper maintenance.
- Damage caused by abuse or careless handling.
- Damage from moisture into electrical components
- Damage from tampering with, removal of, or changing any preset control or safety device.

Service/Technical Assistance

If you experience any problems with the installation or operation of your unit, contact your local Authorized Service Agency. They can be found in the service agency directory packaged with the equipment.

Fill in the information below and have it handy when calling your Authorized Service Agency for assistance. The serial number is on the specification plate located on the rear of the unit.

Purchased From: _____

Date of Purchase: _____

Model No.: _____

Serial No.: _____

Mfg. No.: _____

Refer to the service agency directory and fill in the information below:

Authorized Service Agency

Name: _____

Phone No.: _____

Address: _____

Use only genuine Roundup replacement parts in this unit. Use of replacement parts other than those supplied by the manufacturer will void the warranty. Your Authorized Service Agency has been factory trained and has a complete supply of parts for this unit.

You may also contact the factory at **1-630-784-1000** or toll free in the United States **1-877-392-7854** if you have trouble locating your Authorized Service Agency.

Model Designation

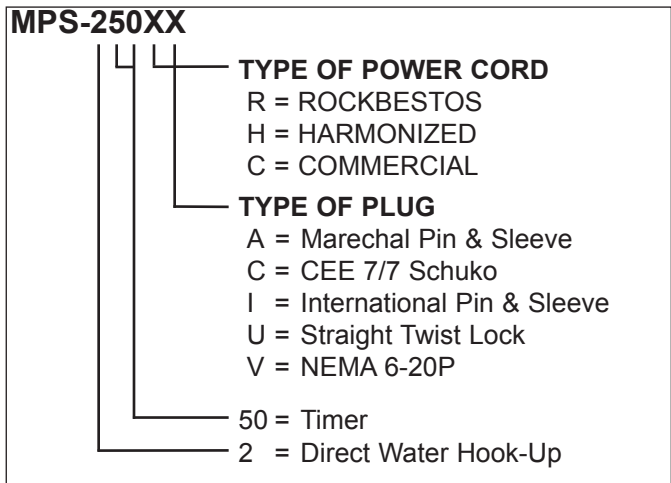

IMPORTANT SAFETY INFORMATION

Throughout this manual, you will find the following safety words and symbols that signify important safety issues with regards to operating or maintaining the equipment.

WARNING

GENERAL WARNING. Indicates information important to the proper operation of the equipment. Failure to observe may result in damage to the equipment and/or severe bodily injury or death.

CAUTION

GENERAL CAUTION. Indicates information important to the proper operation of the equipment. Failure to observe may result in damage to the equipment.

WARNING

ELECTRICAL WARNING. Indicates information relating to possible shock hazard. Failure to observe may result in damage to the equipment and/or severe bodily injury or death.

WARNING

HOT SURFACE WARNING. Indicates information important to the handling of equipment and parts. Failure to observe may result in personal injury.

In addition to the warnings and cautions in this manual, use the following guidelines for safe operation of the unit.

- Read all instructions before using equipment.
- For your safety, the equipment is furnished with a properly grounded cord connector. Do NOT attempt to defeat the grounded connector.
- Install or locate the equipment only for its intended use as described in this manual. Do NOT use corrosive chemicals in this equipment.
- Do NOT operate this equipment if it has a damaged cord or plug; if it is not working properly, or if it has been damaged or dropped.
- This equipment should be serviced by qualified personnel only. Contact the nearest Authorized Service Agency for adjustment or repair.
- Do NOT block or cover any openings on the unit.
- Do NOT immerse cord or plug in water.
- Keep cord away from heated surfaces.
- Do NOT allow cord to hang over edge of table or counter.

The following warnings and cautions appear throughout this manual and should be carefully observed.

- Turn the power off, unplug the power cord, and allow the unit to cool down before performing any service or maintenance.
- The procedures in this chapter may include the use of chemical products. These chemical products will be highlighted with bold face letters followed by the abbreviated HCS (Hazard Communication Standard). See Hazard Communication Standard manual for the appropriate Material Safety Data Sheets (MSDS).
- The equipment should be grounded according to local electrical codes to prevent the possibility of electrical shock. It requires a grounded receptacle with separate electrical lines, protected by fuses or circuit breaker of the proper rating.
- All electrical connections must be in accordance with local electrical codes and any other applicable codes.

IMPORTANT SAFETY INFORMATION (continued)

- **WARNING ELECTRICAL SHOCK HAZARD. FAILURE TO FOLLOW THESE INSTRUCTIONS COULD RESULT IN SERIOUS INJURY OR DEATH.**
 - Electrical ground is required on this unit.
 - Do NOT modify the power supply cord plug. If it does not fit the outlet, have a proper outlet installed by a qualified electrician.
 - Do NOT use an extension cord with this appliance.
 - Check with a qualified electrician if you are unsure if the appliance is properly grounded.
 - Electrical ground is required on this unit.
If the supply cord is damaged, it must be replaced by the manufacturer, its service agent, or a similar qualified person in order to avoid a hazard.
- This equipment is to be installed to comply with the basic plumbing code of the Building Officials and Code Administrators, Inc. (BOCA) and the Food Service Sanitation Manual of the Food and Drug Administration (FDA).
- Water pressure must not exceed 30 psi (207 kPa). Higher water pressures may cause poor performance or flooding. To reduce water pressure, install a Water Pressure Regulator and set to 20 psi (1.4 kg/cm² or 138 kPa). To order a Water Pressure Regulator from your Authorized Service Agency, order Roundup part number 7000235.
- To ensure proper steaming characteristics, some mineral deposits must be present on generator casting.
- If, during cleaning, the casting does become free of mineral deposits, add plain tap water to casting and allow it boil off. This will ensure proper steaming characteristics by creating a thin layer of mineral deposits on the casting.
- Do NOT clean this appliance with a water jet.
- Do NOT use a sanitizing solution or abrasive materials. The use of these may cause damage to the stainless steel finish.
- Chlorides or phosphates in cleaning agents (e.g. bleach, sanitizers, degreasers, or detergents) could cause permanent damage to stainless steel equipment. The damage is usually in the form of discoloration, dulling of metal surface finish, pits, voids, holes, or cracks. This damage is permanent and not covered by warranty.
- This appliance is NOT intended for use by persons (including children) with reduced physical, sensory, or mental capabilities, or lack of experience and knowledge, unless they have been given supervision or instruction concerning use of the appliance by a person responsible for their safety. Children should be supervised to ensure that they do NOT play with the appliance.

The following tips are recommended for maintenance of your stainless steel equipment,

- Always use soft, damp cloth for cleaning, rinse with clear water and wipe dry. When required, always rub in direction of metal polish lines.
- Routine cleaning should be done daily using soap, ammonia detergent, and water.
- Stains and spots should be removed using a vinegar solution as required.
- Finger marks and smears should be rubbed off using soap and water.
- Hard water spots should be removed using a vinegar solution.

IMPORTANT

A.J. Antunes & Co. reserves the right to change specifications and product design without notice. Such revisions do not entitle the buyer to corresponding changes, improvements, additions or replacements for previously purchased equipment.

SPECIFICATIONS

Electrical Ratings

| Model & Mfg. No. | Supply Voltage | Watts | Amps | Hertz |
|--|----------------|----------------|----------------|-------|
| MPS-250CV 9100320 9100340 | 220 - 240 | 3019 - 3593 | 13.7 - 15.3 | 50/60 |
| MPS-250CU 9100334 | 220 - 240 | 3019 - 3593 | 13.7 - 15.3 | 50/60 |
| MPS-250HC 9100330 9100342 | 220 - 240 | 3019 - 3593 | 13.7 - 15.3 | 50/60 |
| MPS-250HI 9100332 9100344 | 220 - 240 | 3019 - 3593 | 13.7 - 15.3 | 50/60 |
| MPS250HA 9100336 9100346 (Australia only) | 220 - 240 | 3019 - 3593 | 13.7 - 15.3 | 50/60 |
| MPS-250HC 9100348 (China only) | 220 - 240 | 3019 - 3593 | 13.7 - 15.3 | 50/60 |

APPROXIMATE WEIGHT: Shipping weight of the MPS-250 is 50 lbs. (22.5 Kg.)

⚠ WARNING ⚠

ELECTRICAL SHOCK HAZARD.





FAILURE TO FOLLOW THE INSTRUCTIONS IN THIS MANUAL COULD RESULT IN SERIOUS INJURY OR DEATH.

- Electrical ground is required on this appliance.
- Do NOT modify the power supply cord plug. If it does not fit the outlet, have a proper outlet installed by a qualified electrician.
- Do NOT use an extension cord with this appliance.
- Check with a qualified electrician if you are unsure if appliance is properly grounded.

⚠ CAUTION ⚠

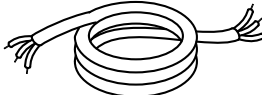
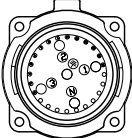
All electrical connections must be in accordance with local electrical codes and any other applicable codes.

Electrical Cord & Plug Configurations

| Letter Code* | Description | Configuration |
|--------------|---|---|
| C R H | Commercial Cord Rockbestos Cord Harmonized Cord |  |
| A | Marechal Pin & Sleeve 16 Amps, 250 VAC |  |
| (H)C | CEE 7/7, 16 Amp., 250 VAC (Assembly Only). |  |
| (H)I | IEC-309, 16 Amp., 250 VAC., Pin & Sleeve (Assembly Only). |  |
| U | L6-20P, 20 Amp., 250 VAC., Straight Twist Lock. |  |
| (C)V | 6-20P, 20 Amp., 250 VAC., Non-Locking (Assembly Only). |  |

* Used in Model Designation

Dimensions

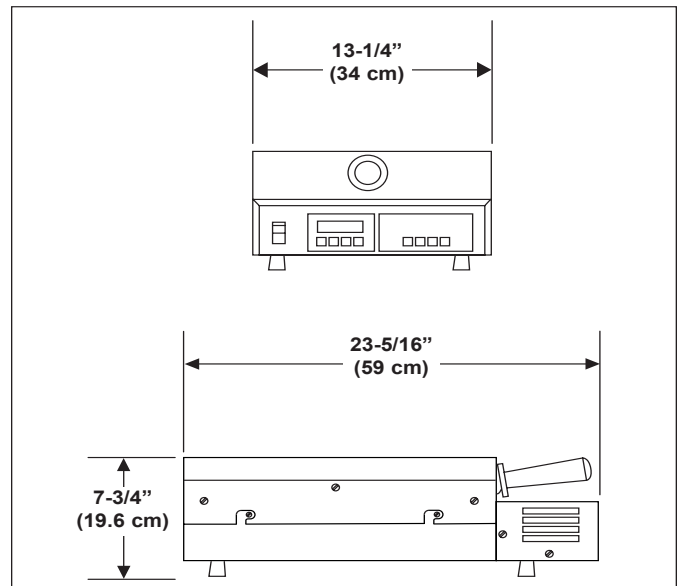

INSTALLATION

Unpacking

1. Remove unit and all packing materials from shipping carton. It should contain the following:
 - Multi-Purpose Steamer
 - Spatula with Handle & Handle Guard
 - Water Hookup Kit
 - Information Packet
2. Remove information packet.
3. Remove all packing materials and protective coverings from the unit.
4. Assemble the handle, handle guard and mounting bolt to the spatula (Figure 1).
5. Remove and wash all removable parts (Spatula, Diffuser, and Top Cover) in soap and water. Rinse with clean hot water and allow to air dry.

NOTE: The Diffuser must be removed before removing the Top Cover.

6. Wipe all surfaces of the unit with a hot damp cloth.

NOTE: Do NOT use a dripping wet cloth. Wring out before use.

7. Re-install all removed parts.

Equipment Setup

GENERAL

When placing the unit into service, pay attention to the following guidelines:

- Make sure power to the unit is off and at room temperature.
- Do NOT block or cover any openings on the unit.
- Do NOT immerse cord or plug in water.
- Keep cord away from heated surfaces.
- Do NOT allow cord to hang over edge of table or counter.

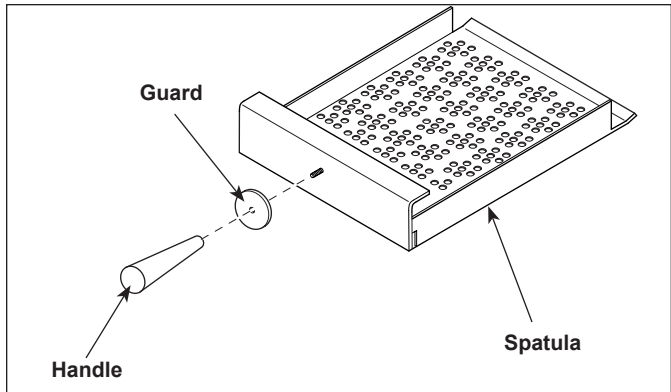

Figure 1. Assembling Handle

ELECTRICAL

1. Place the unit on a sturdy, level table or other work surface. Turn off the power before proceeding.
2. Ensure that the line voltage corresponds to the stated voltage on the unit's specification label and power cord warning tag.
3. Connect the unit to the power supply.

⚠ CAUTION ⚠

All electrical connections must be in accordance with local electrical codes and any other applicable codes.

⚠ WARNING ⚠

ELECTRICAL SHOCK HAZARD.

FAILURE TO FOLLOW THE INSTRUCTIONS IN THIS MANUAL COULD RESULT IN SERIOUS INJURY OR DEATH.

- **Electrical ground is required on this appliance.**
- **Do NOT modify the power supply cord plug. If it does not fit the outlet, have a proper outlet installed by a qualified electrician.**
- **Do NOT use an extension cord with this appliance.**
- **Check with a qualified electrician if you are unsure if the appliance is properly grounded.**

INSTALLATION (continued)

NOTE: Multi-Purpose Steamer models are designed to use cold tap water.

The MPS-250 requires a direct water hookup. An installation kit is packed inside the unit.

NOTE: Restaurants that use the FBS-90 steamer should utilize the same water connection provided it is located after the IMF and/or any other water treatment system.

OPTIONAL AJA REGULATOR INSTALLATION INSTRUCTIONS

1. Install manifold/regulator assembly to the steamer as shown using #8 bracket screws supplied.

NOTE: The AJA Water Pressure Regulator Kit, P/N 7000235, has the capacity to feed two steamers simultaneously (Figure 2).

2. Open the shut-off valve to allow water flow to the regulator. Ensure that the Water Pressure Regulator is set at 20 psi. If not, confirm that incoming water pressure is above 25 psi and if so, adjust the regulator by pulling softly on the knob and turning until gauge reads desired pressure. Push in the knob to lock.

NOTE: If pressure was adjusted, existing pressure must be relieved in order to register new set pressure.

3. Push in the outlet sleeve of one 1/4" "QD" elbow fitting (attached to manifold) and hold for two minutes to purge out air in the line and allow water to flow freely into a bucket with a steady stream.
4. Connect the 1/4" "QD" to the steamers as shown. Turn on the steamers and allow 20 minutes to warm up. Cycle the units 3 times and check the pressure regulator setting. If there is a change, adjust it again to read 20 to 30 psi and then push the knob to lock. Your steamer(s) is ready to be used.

⚠ CAUTION ⚠

Water pressure must not exceed 30 psi (or 207 kPa). Higher water pressures may cause poor performance or flooding. To reduce water pressure, install a Water Pressure Regulator, and set to 20 psi (1.4 kg/cm² or 138 kPa). To order a water pressure regulator from your Authorized Service Agency, order Roundup part no. 7000235.

⚠ CAUTION ⚠

This equipment is to be installed to comply with the basic plumbing code of the Building Officials and Code Administrators, Inc. (BOCA) and the Food Service Sanitation Manual of the Food and Drug Administration (FDA).

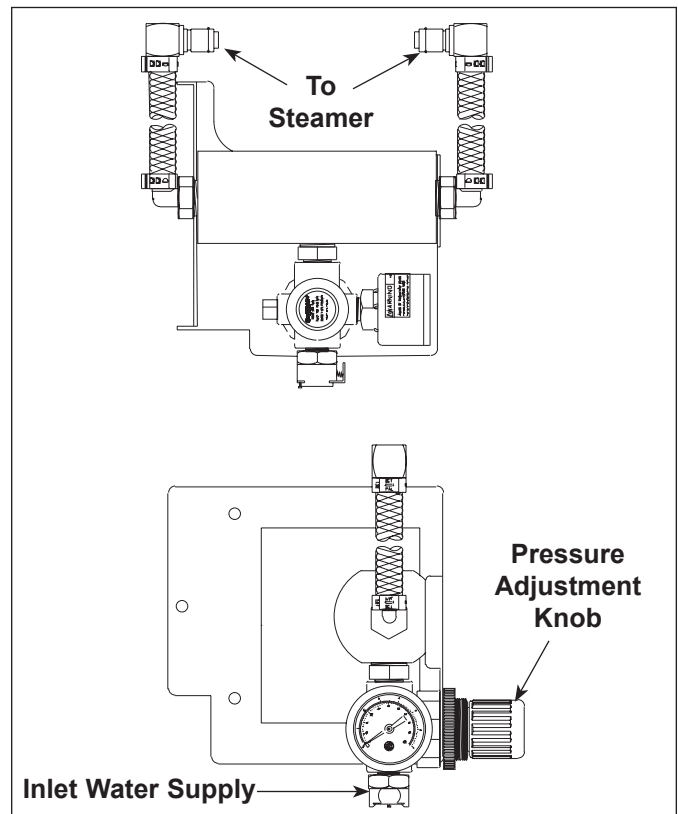

Figure 2. Water Pressure Regulator P/N 7000235

INSTALLATION (continued)

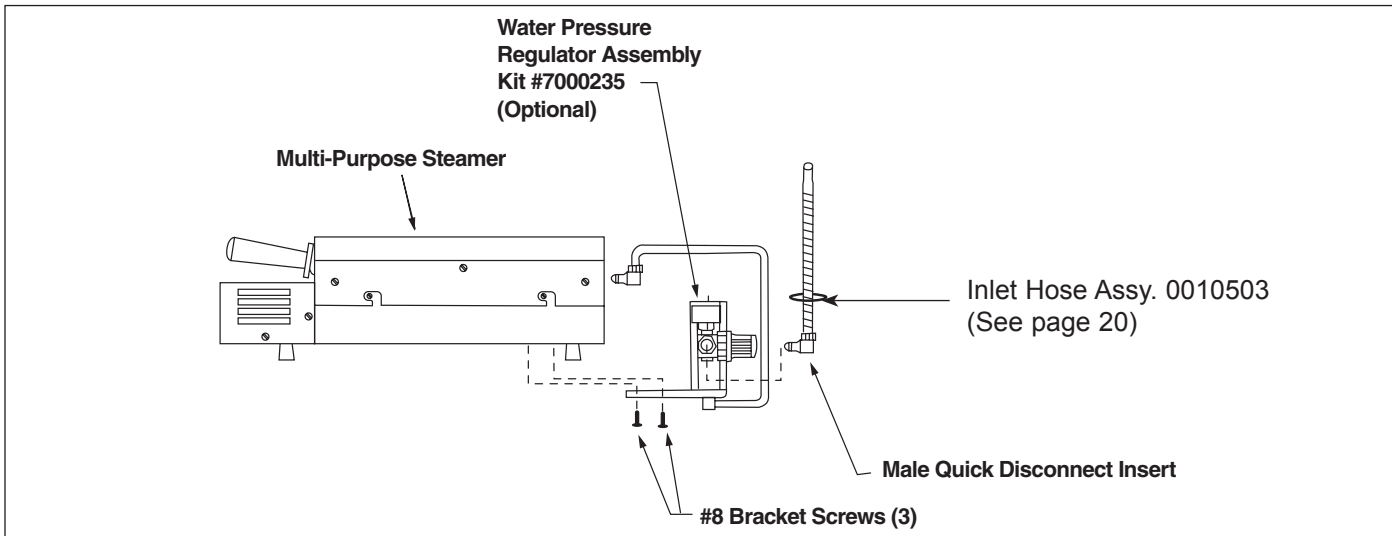

Figure 3. Connecting Water Supply to MPS-250

OPERATION

General

ROCKER SWITCH (POWER ON/OFF)

When the power is on (Figure 4), the control board is activated and a thermostat senses generator temperature. If generator temperature is below the factory preset setpoint, power is applied to the generator until setpoint is reached. The generator is constantly monitored and power is regulated to maintain temperature setpoint.

MENU BUTTONS

When any menu button is pressed and released, power is supplied to the solenoid, the solenoid operates and water sprays onto the heated steam generator. The water flashes immediately into live steam and shoots down onto the product.

One of two operational modes can be used: **Single Shot** or **Timed Cycle**

SINGLE SHOT

The **SINGLE SHOT** button (Figure 4), is pressed to initiate a single timed shot. The control board applies power to the solenoid and a timed "shot" of steam occurs.

TIMED CYCLE

The desired timed cook cycle (up to 99 minutes, 59 seconds) is selected by pressing and releasing any of the four menu buttons (Figure 4). The main control board applies power to the solenoid at regular intervals

for the duration of the displayed cycle time. The display counts down to zero when the cycle is complete, then reverts back to the original programmed cycle time and the unit is ready for the next cycle.

IMPORTANT: Your Multi-Purpose Steamer is factory programmed for the following on each of its four channels except for models 9100336 and 9100346 (see "Exception" on next page).

Channel 1: 6 BUNS

- Total Cycle Time (CYC) = 30 seconds [0030] (Range: 1 sec to 99 mins 59 secs)
- Shot Interval Time (RATE) = 6 seconds [0006] (Range: 1 sec to 5 mins 59 secs)
- Steam Shot Time (SHOT) = 0.70 seconds [0_70] (Range: 0.10 sec to 2.50 secs)

Channel 2: 4 BUNS

- Total Cycle Time (CYC) = 20 seconds [0020] (Range: 1 sec to 99 mins 59 secs)
- Shot Interval Time (RATE) = 5 seconds [0005] (Range: 1 sec to 5 mins 59 secs)
- Steam Shot Time (SHOT) = 0.70 seconds [0_70] (Range: 0.10 sec to 2.50 secs)

OPERATION (continued)

Channel 3: 2 BUNS

- Total Cycle Time (CYC) = 12 seconds [0012]
(Range: 1 sec to 99 mins 59 secs)
- Shot Interval Time (RATE) = 3 seconds [0003]
(Range: 1 sec to 5 mins 59 secs)
- Steam Shot Time (SHOT) = 0.70 seconds [0_70]
(Range: 0.10 sec to 2.50 secs)

Channel 4: SAME AS FBS-90

- Total Cycle Time (CYC) = 90 seconds [0090]
(Range: 1 sec to 99 mins 59 secs)
- Shot Interval Time (RATE) = 30 seconds [0030]
(Range: 1 sec to 5 mins 59 secs)
- Steam Shot Time (SHOT) = 0.70 seconds [0_70]
(Range: 0.10 sec to 2.50 secs).

Exception:

For Manufacturing numbers 9100336 and 9100346, all four channels are factory programmed with the same settings as Channel 1 above.

⚠ WARNING ⚠

To avoid injury, be careful when pulling Spatula out from unit. Be sure to allow steam to escape before putting hands or face over the steamer.

Operating Instructions

1. Turn the power on (Figure 4).
2. Allow the unit to preheat for approximately 20-30 minutes.

NOTE: The display will read "LOW" until the unit reaches operating temperature.

3. Pull out the Spatula and place the product to be steamed onto the Spatula.
4. Push the Spatula fully into the steamer.
5. To steam:

SINGLE SHOT: Press the single shot button momentarily, (1 second) and wait for the steam to penetrate the product.

TIMED CYCLE: Press the appropriate menu button to begin the steaming cycle. Display will count down to zero.

6. Remove steamed product.

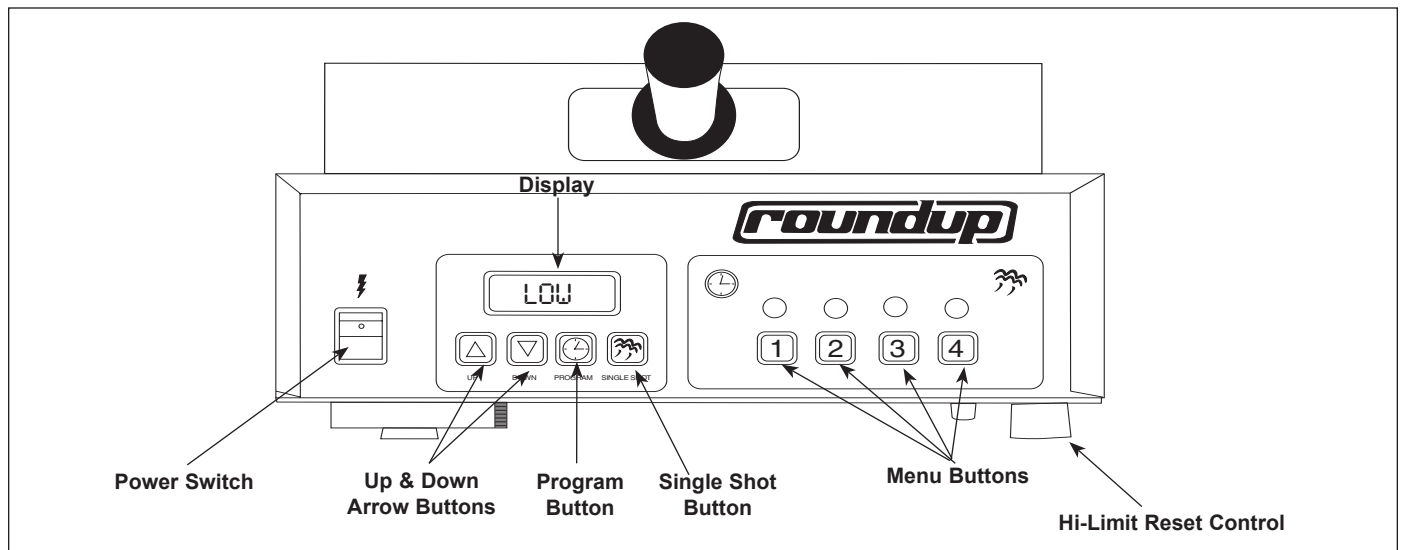

Figure 4. Operating Controls

PROGRAMMING

Programming

CHANGE (F) Fahrenheit or (C) Celsius

Depending on operation, change (F) Fahrenheit to (C) Celsius or (C) Celsius to (F) Fahrenheit.

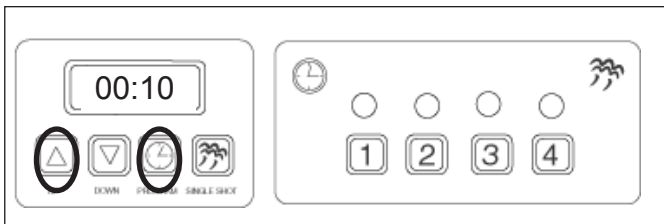

To Change the display from *Fahrenheit (F)* to *Celsius (C)*, press and hold the **UP** arrow and the **PROGRAM** buttons simultaneously for three seconds. Repeat the process to reverse.

CYC (Total Cycle Time) refers to the total amount of cooking time set for the product on any particular menu channel.

RATE (Shot Interval Time) is the time set between shots of steam during a complete cycle.

SHOT (Steam Shot Time) is used to adjust the water volume during each solenoid operation, or “shot” of steam.

The amount of steam produced by your unit depends on the amount of water sprayed onto the steam Generator.

Flooding of the Generator may occur if the H₂O setting (SHOT) is set too high. To prevent this from occurring, the Shot Interval Time (RATE) could be increased to allow more time for Generator recovery, and/or the Steam Shot Time (SHOT) could be decreased to reduce water volume. Adjustments should be made to both values to determine the optimum settings for your cooking needs.

NOTE: CYC, RATE and SHOT are sequential operation per channel for all programming. (You must perform all steps for CYC and RATE to only change SHOT).

To program the control, refer to Figure 5 and use the following procedure in sequence:

CYC (Total Cycle Time)

1. Turn the power on.
2. Press the PROGRAM button (Figure 4) to change the control from OPERATION to PROGRAM mode. The default setting will appear in the display (Figure 5, Item A).

NOTE: If no change is made within 10 seconds at any time during the programming process, all changes made up to that point are stored in memory and the control reverts to OPERATION mode.

3. Press the UP or DOWN arrow buttons to change the total cycle time in minutes (Figure 5, Item B).
4. Press the PROGRAM button again, then use the UP or DOWN arrow buttons to change the total cycle time in seconds (Figure 5, Item C).

RATE (Shot Interval Time)

5. Press the PROGRAM button again, then Press both UP and DOWN arrow keys simultaneously. “**RATE**” will be displayed (Figure 5, Item D).
6. Use the UP or DOWN arrow buttons to change the RATE setting in seconds.

To change the RATE in minutes (Figure 5, Item E), press the PROGRAM button within 10 seconds of setting the seconds, then use the UP or DOWN arrow buttons to increase or decrease the time.

SHOT (Steam Shot Time)

8. Press the PROGRAM button again and SHOT will be displayed (Figure 5, Item F).
9. Use the UP or DOWN arrow buttons to increase or decrease the time (Figure 5, Item G).
10. Press the SINGLE SHOT button to store the changes and exit the PROGRAM mode.

PROGRAMMING (continued)

NOTE: Use the UP or DOWN Arrow Buttons to change the minute or second time interval

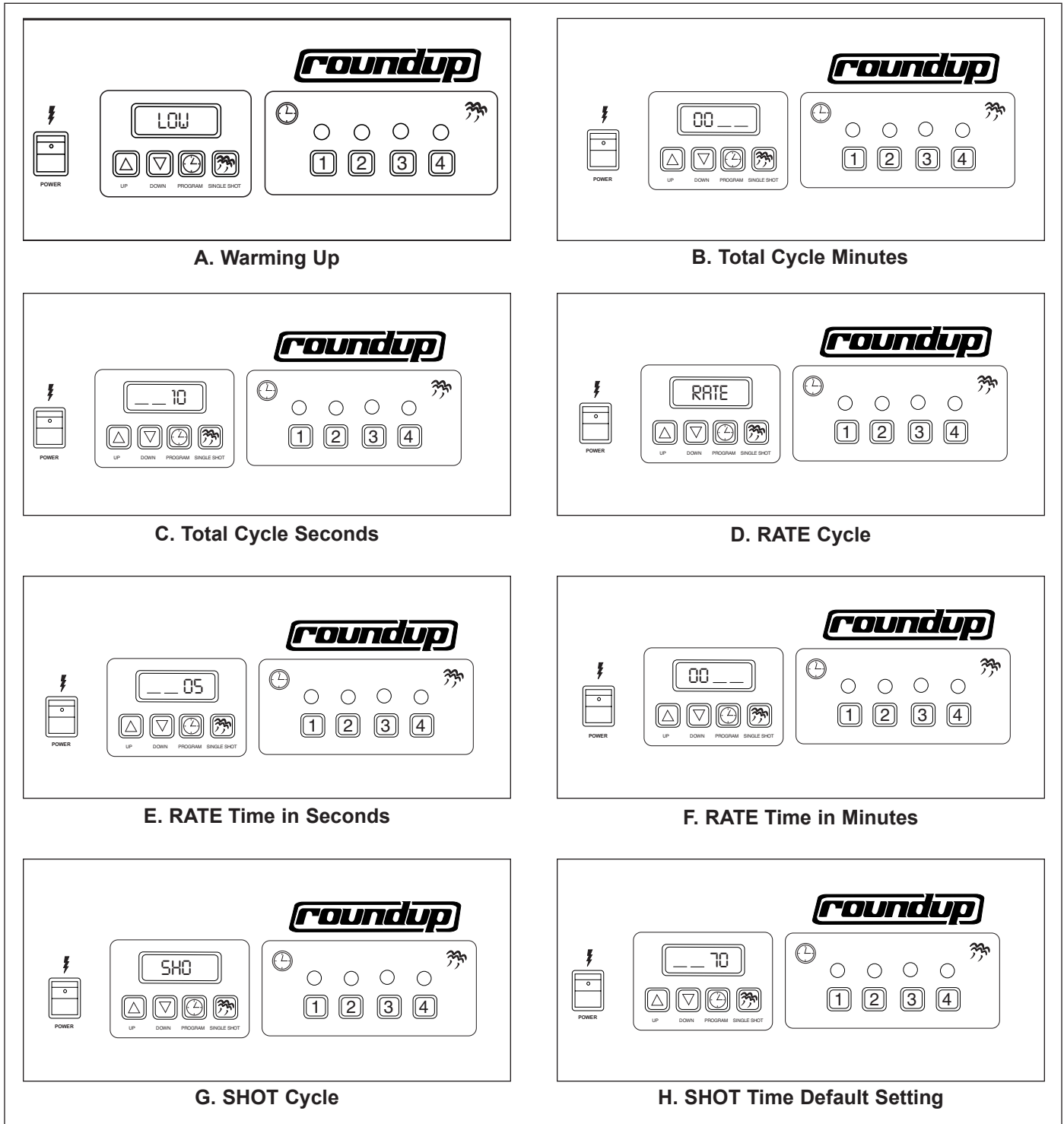

Figure 5. Control Programming Sequence

MAINTENANCE

⚠ CAUTION ⚠

Before performing any maintenance, be sure to read and follow all warnings and instructions listed in the Important Safety Information section of this manual.

⚠ WARNING ⚠

Turn the power off, unplug the power cord, and allow the unit to cool down before performing any service or maintenance.

⚠ CAUTION ⚠

Do NOT use a sanitizing solution or abrasive materials. The use of these may cause damage to the stainless steel finish.

⚠ CAUTION ⚠

If a chemical cleaner is used, be sure it is safe to use on cast aluminum. Observe all precautions and warnings on product label.

Maintenance Schedule

NOTE: Frequency of cleaning is determined by water conditions, usage and water filter systems. Water hardness, or Total Dissolved Solids (TDS), should not exceed 60 ppm (parts per million)

Daily

1. Turn the power off, unplug the power cord, and allow the unit to cool down before proceeding.
2. Check the water quick disconnect fitting and all hose clamp connections for leakage. If leakage is apparent, tighten all clamps or replace part if required.
3. Remove the Spatula, Diffuser and Top Cover.

NOTE: The Spatula, Diffuser and Top Cover must be removed in this specific order. Failure to do so may result in damage to the equipment.

4. Clean the Spatula, Diffuser and Top Cover in hot detergent water, rinse in clear water, and allow to air dry.
5. Clean the chamber of any product spills. Spray McD All Purpose Super Concentrate on a clean dry towel, clean the entire unit, and then wipe dry.
6. Re-install the Top Cover, Diffuser, and Spatula.

NOTE: The Top Cover, Diffuser, and Spatula must be installed in this specific order. Failure to do so may result in damage to the equipment.

CHECKING AND CLEANING THE WATER PRESSURE REGULATOR KIT STRAINER

To ensure proper and consistent steaming results, visually check the Water Pressure Regulator Gauge and Strainer Cup regularly. If the pressure on the gauge has dropped, visually check the clear plastic Strainer Cup and clean out the accumulated debris as follows.

1. Shut off the water supply valve to the unit, unscrew the clear plastic Strainer Cup and carefully remove the mesh strainer screen.
2. At the sink, gently flush the accumulated debris from the Strainer Cup and mesh strainer screen being especially careful not to damage the mesh strainer screen.
3. Carefully place the mesh strainer screen into its seat at the bottom of the clear plastic cup and confirm that the orange O-ring is properly seated in its place before screwing the Strainer Cup and top back together.
4. Purge the air out of the strainer and tubing by disconnecting the male quick disconnect fitting from the equipment and, over a bucket, pushing its valve core in until there is a good water flow.

Monthly

Your Multi-Purpose Steamer utilizes an open steam generator. When introduced, water immediately vaporizes into a burst of steam, leaving behind any minerals it contained. Though a small amount of minerals are necessary for proper operation, excessive amounts will cause poor steaming and may permanently damage the generator.

Cleaning Steam Generator

1. Turn the power off, unplug the power cord, and allow the unit to cool down before proceeding.
2. Remove the Spatula, Diffuser, and Top Cover from unit.

NOTE: The Spatula, Diffuser, and Top Cover must be removed in this specific order. Failure to do so may result in damage to the equipment.

3. Examine the generator orifice (hole). If mineral deposits have formed, place a flat blade screwdriver into the opening. Use a twisting motion to scrape openings clean.

NOTE: If the mineral deposits from the generator surface come off in "flakes" or in layers, the mineral build-up is excessive.

MAINTENANCE (continued)**Monthly cont'd**

4. Use an abrasive, plastic bristle cleaning brush and small scraper to remove deposits from the generator surface.
5. If necessary, pour McD Delimer solution (not supplied) onto the generator surface and allow to soak according to the product's instructions. Remove the delimer solution from the generator and rinse with clear water to remove traces of delimer.

NOTE: Be sure to follow the delimer manufacturer's directions for proper mixture and use.

6. Clean the Spatula, Top Cover, and Diffuser in hot, detergent water, then rinse in clear water, and allow to air dry:
7. Clean unit surface with a hot, clean, damp cloth (not dripping wet) and wipe dry.

NOTE: The Top Cover, Diffuser, and Spatula must be installed in this specific order. Failure to do so may result in damage to the equipment.

8. Re-install all parts ensuring the Top Cover is secure.
9. Plug in power cord and water line (if applicable).

NOTE: To ensure proper steaming characteristics, some mineral deposits must be present on generator casting. If during cleaning, the casting does become free of mineral deposits, add ordinary tap water (non reverse osmosis or ionic filter system) to casting and allow to boil off.

NOTE: In soft water areas, it may be necessary to add a small amount of lime to generator to "season" it (see seasoning formula). This will ensure proper steaming characteristics by producing a thin coating of mineral deposits on the casting.

Seasoning Formula: Mix one ounce (28 grams/33 ml) baking soda, and one ounce (28 grams/33ml) lime in one quart (one liter) of water.

Pour 1/4" deep of seasoning mixture into a cold generator. Turn the unit on. After mixture is converted to steam, the remaining loose powder is removed and generator cleaned.

Flushing/Cleaning Water Solenoid

The Multipurpose Steamer can be programmed to provide a much larger volume of water per water shot to flush/clean the Solenoid Base.

NOTE: Based on the water conditions in your area. Flushing/Cleaning of the Water Solenoid should be done at the same time as the "Cleaning the Steam Generator" per the PM Card #XT 101. This procedure is done monthly but based on water conditions could be done weekly or daily.

To perform the water Solenoid flushing/cleaning on the Multi-Purpose Steamer, Model MPS 250, you will have to reprogram the "SHOT" time on the Product Menu Button #1. **Currently the standard "SHOT" setting is 0.70 second.**

1. Follow the instructions in the Programming section to change the "SHOT" setting to 2.5 seconds.

This is the maximum time that can be programmed.

2. Make sure the steamer is up to operating temperature.
3. Run one cycle using button #1.
 - You will get 5 water shots in 30 seconds
 - The longer "SHOT" time will generate a larger volume of water flowing through the solenoid. This increased volume of water will flush/clean the water Solenoid Base.

NOTE: This volume of water will flood the casting.

4. When the cycle is completed, you may want to run a second cycle.
 - Wait until all the water has turned to steam before using or turning the Steamer off.

NOTE: It is very important to reprogram the water "SHOT" back to it's 0.70 second setting or original setting.

DIAGNOSTICS

Diagnostics

The four-channel controller is also equipped with diagnostic features. Listed under each drawing is a brief description of the particular feature. Also contained in the control housing mounted on the control board are diagnostic LED's. They are in three colors and represent the following:

- * **Green (Program):** When lit, indicates default settings are being set.
- * **Yellow (Audio):** When lit, indicates power is being sent to the audio device.
- * **Red (Heat):** When lit, indicates the unit is calling for heat.
- * **Green (Water):** When lit, indicates that power is being sent to the water pump or solenoid.

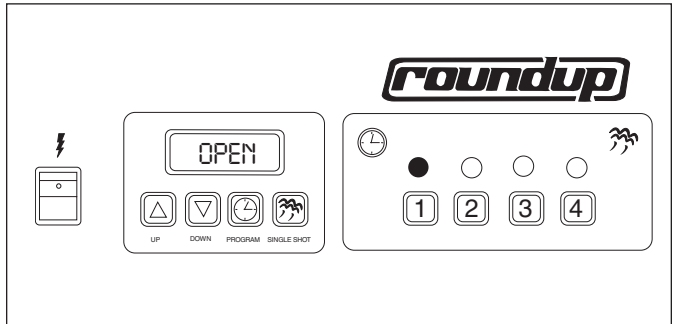

OPEN will be displayed when the thermocouple is damaged or not installed correctly.

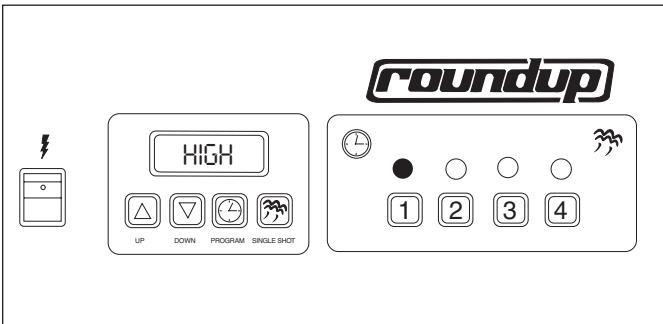

HIGH will be displayed when the Generator temperature exceeds the setpoint temperature by 50°F (10°C).

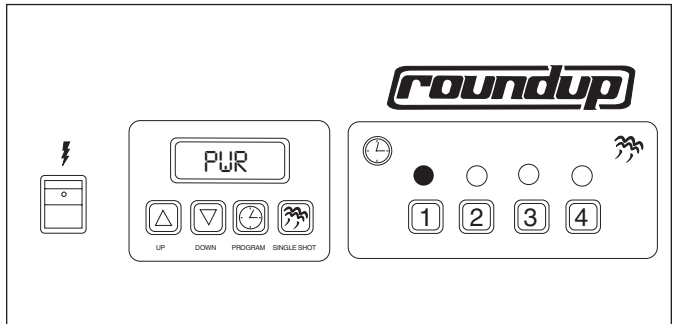

PWR (Power) will be displayed when the supply voltage is lower than 160 Volts AC or above 265 Volts AC.

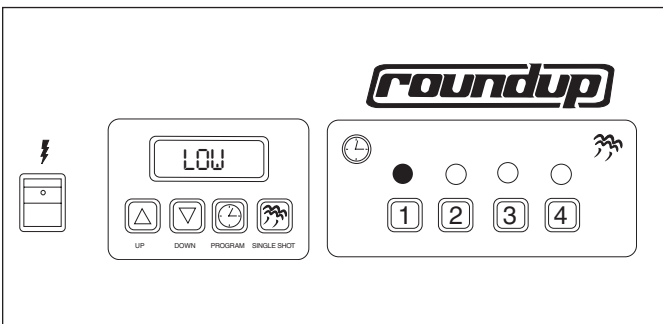

LOW will be displayed until the Generator temperature exceeds 250°F (121°C).

NOTE: For Manufacturing # 9100336 and 9100346, the low limit temperature is 365° F (185° C).

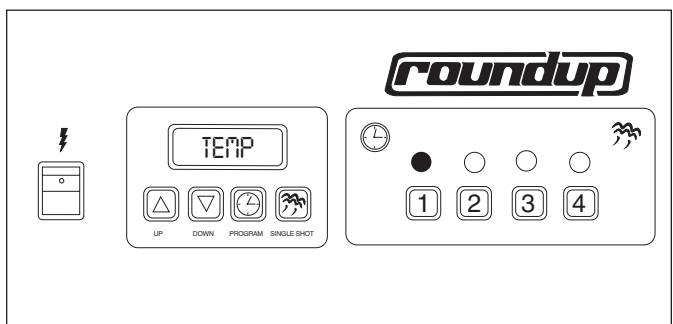

TEMP indicates the control cabinet temperature has exceeded 155°F (68°C) causing the unit to shut down. If this indication occurs turn the unit off and allow the unit to cooling for 20 minutes.

DIAGNOSTICS (continued)

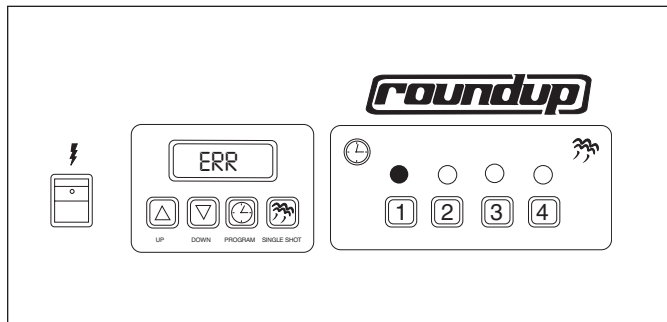

ERR (Error) will be displayed when there are programming parameter errors. If this message appears, you may have to clear the current parameters.

To clear the unit's current programming and reset the unit to its' factory default settings:

1. Turn the unit off.
2. Push the **START/STOP** and **DOWN ARROW** keys simultaneously and, while turning the unit back on continue to hold them until you hear the unit BEEP (and then stops).
3. Check the Display.
 - If the Display shows "ERR" again, contact Roundup for technical assistance.
 - If the Display appears normal, try both a single shot and factory default timed cycles before attempting to reprogram the unit.

Review the Programming section of this manual (Page 8) and then program the Menu Channel Buttons according to your cooking requirements.

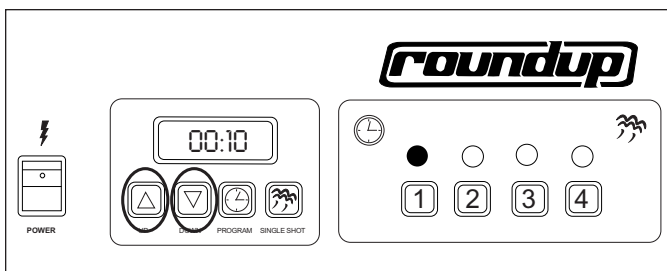

To change the Setpoint temperature, press and hold the **UP** and **DOWN** arrows simultaneously for three seconds. Then, raise or lower the temperature by Pressing the **UP** or **DOWN** arrows. Minimum temperatures should be 375°F (191° C).

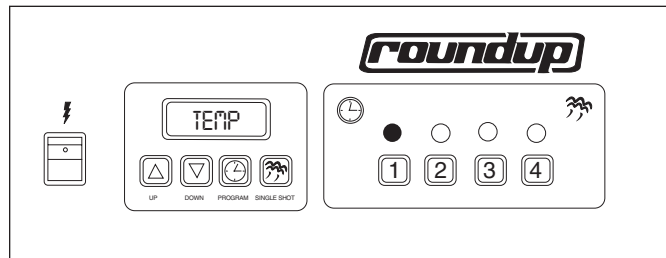

TEMP indicates the control cabinet temperature has exceeded 155°F (68°C) causing the unit to shut down.

The TEMP Display indicates that the control cabinet temperature has exceeded 155°F (68°C). If this occurs, the unit must be turned off for at least 20 minutes so that it can cool off and reset.

If this condition reoccurs, contact your Authorized Service Agency or Roundup Technical Assistance.

The control board monitors the control cabinet ambient temperature and records whatever its highest temperature has been. Your service technician could find such information very useful when troubleshooting the unit.

To determine what the control cabinet's highest temperature has been since it was last reset:

1. Turn the unit off.
2. Turn the unit back On while pressing both the **UP** and **DOWN ARROWS** at the same time.
3. Read the highest control cabinet temperature recorded on the display and release the arrow keys.
4. Turn the unit off again to preserve this record.

To clear/reset this record, press both the **UP** and **DOWN ARROWS** and **PROGRAM** button simultaneously (before turning the unit off) and the display will show 33°F - indicating that the record has been cleared - and then turn the unit off.

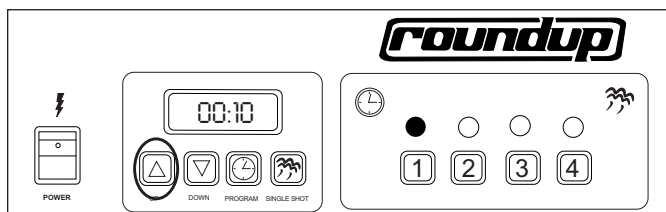

To check the GENERATOR temperature, press and hold the **UP** arrow. The display will read the set temperature.

TROUBLESHOOTING

▲ CAUTION ▲

To avoid possible personal injury and/or damage to the unit, inspection, test and repair of electrical equipment should be performed by qualified service personnel. The unit should be unplugged when servicing, except when electrical tests are required.

| Problem | Possible Cause | Corrective Action |
|---|---|---|
| Unit is turned on but the Switch Indicator Light is still off and the Control Panel is blank. | The unit is not correctly plugged in. | Plug unit in correctly. |
| | The power cord and/or electrical plug is damaged. | Inspect electrical wire, plug, and receptacle. |
| | The main electrical panel circuit breaker is off or has been tripped. | Reset circuit breaker. Contact your maintenance person or Authorized Service Agency if it trips again. |
| | Switch is inoperable. | Contact your maintenance person or Authorized Service Agency for service. |
| The unit's main electrical panel circuit breaker trips. | Damaged receptacle, plug, or cord; a loose connection or an internal component failure. | Turn the power off, allow it to cool to room temperature, and then restart the unit. |
| The unit and Indicator Light are on, but the display is blank. | Hi-Limit Control shut unit off. | |
| | Hi-Limit Control Failure. | |
| | Transformer failure. | Contact your maintenance person or Authorized Service Agency for service. |
| Unit is turned on, the Switch Indicator light is on, the control panel display is on, but the unit is not heating up. | Heat Relay is inoperable. | Contact your maintenance person or Authorized Service Agency for service. |
| | Thermocouple is inoperable. | |
| | Control Board is inoperable. | |
| | Heating element is inoperable | |
| Unit heats up, the control panel is on, but there is little or no steam produced And/or The unit steams, but is not producing the desired results. | The Quick Disconnect water line is not corrected properly (or is restricted). | Disconnect the Quick Disconnect fitting and press its center piece in, over a container, to check the water supply flow and pressure. |
| | Main water supply valve is turned off. | Verify that the main water line valve is open. |
| | Water pressure to the building and/or to the unit is very low. | The water pressure regulator should be set at 20-35 psi or 138 to 207 kPa. |
| | Main water supply filter is plugged. | Clean or replace water line filter/strainer. |
| | Programming is incorrect. | Check program and review the Programming section of this manual. |
| | Setpoint temperature maybe be too low. | Temperature range is 375°–425°F (191°–218°C). |
| | Diffuser may not be installed. | Install Diffuser. |
| | Programming may need to be changed. | Refer to the Programming section within this manual. |
| | Generator surface needs cleaning. | Follow this manual's cleaning instructions. |
| | Generator surface is too clean. | Add ordinary tap water to the Generator surface and allow it to boil off, or follow the "seasoning" instructions in the Maintenance section of this manual. |

TROUBLESHOOTING (continued)

| Problem | Possible Cause | Corrective Action |
|--|--|---|
| Unit floods overnight and/or continues to steam even when in Ready mode. | Solenoid valve is being held open by debris from the building's water line piping. | Attempt to flush the debris out of the valve by rapidly operating the unit on a number of "Single Shot" cycles and then letting it rest. Or, follow the Flushing/Cleaning Water Solenoid instructions within the Maintenance section of this manual. If the unit still leaks, contact your maintenance person or Authorized Service Agency. |
| | There is no pre-strainer/filter on the water line just before the unit. | |
| | The water supply line filters were changed just shortly before this started. | |

To restore factory default settings:

1. Turn the power off.
2. Press and hold PROGRAM and SINGLE SHOT buttons.
3. Turn power on while still holding the PROGRAM and SINGLE SHOT buttons.
4. Release the PROGRAM and SINGLE SHOT buttons as soon as the unit stops beeping.

To clean Inlet Hose Assy. #0010503:

1. Close ball valve (#12 on page 20).
2. Press SINGLE SHOT button once to release pressure.
3. Take small pan or bucket and place it under the filter/strainer cup (#14 on page 20).
4. Unscrew clear plastic cup (#14), remove strainer screen and rinse both under faucet.
5. Re-install the strainer screen in the O-ring of the clear plastic cup.
6. Screw the clear plastic cup back on the body of the stainer, open the ball valve and press the SINGLE SHOT button 3-4 times to bring water back into the hose.

CHECKING AND CLEANING THE WATER STRAINER

To ensure proper and consistent steaming results, check the Water Pressure Regulator gauge and strainer cup regularly. If the water pressure on the gauge has dropped, check the clear plastic strainer cup and clean out the accumulated debris as follows:

1. Shut off the water supply valve to the unit. Unscrew the clear plastic strainer cup and carefully remove the mesh strainer screen.
2. At the sink, gently flush all of the accumulated debris from the strainer cup and mesh strainer screen. Be especially careful not to damage the mesh strainer screen.
3. Carefully place the mesh strainer screen into its seat at the bottom of the clear plastic cup and confirm that the orange O-ring is properly seated in its place before screwing the strainer cup and top back together.
4. Purge the air out of the strainer tubing by disconnecting the male quick disconnect fitting from the equipment and, over a bucket, pushing its valve core in until there is a good water flow.

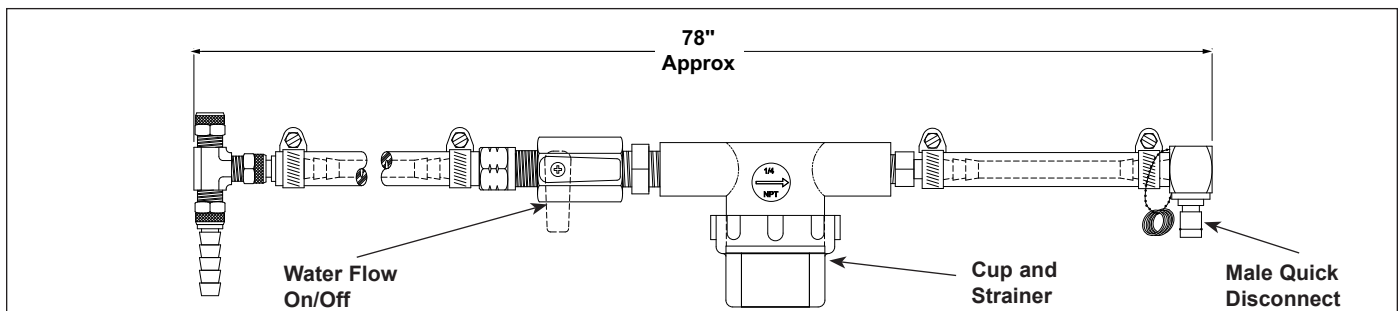

REPLACEMENT PARTS

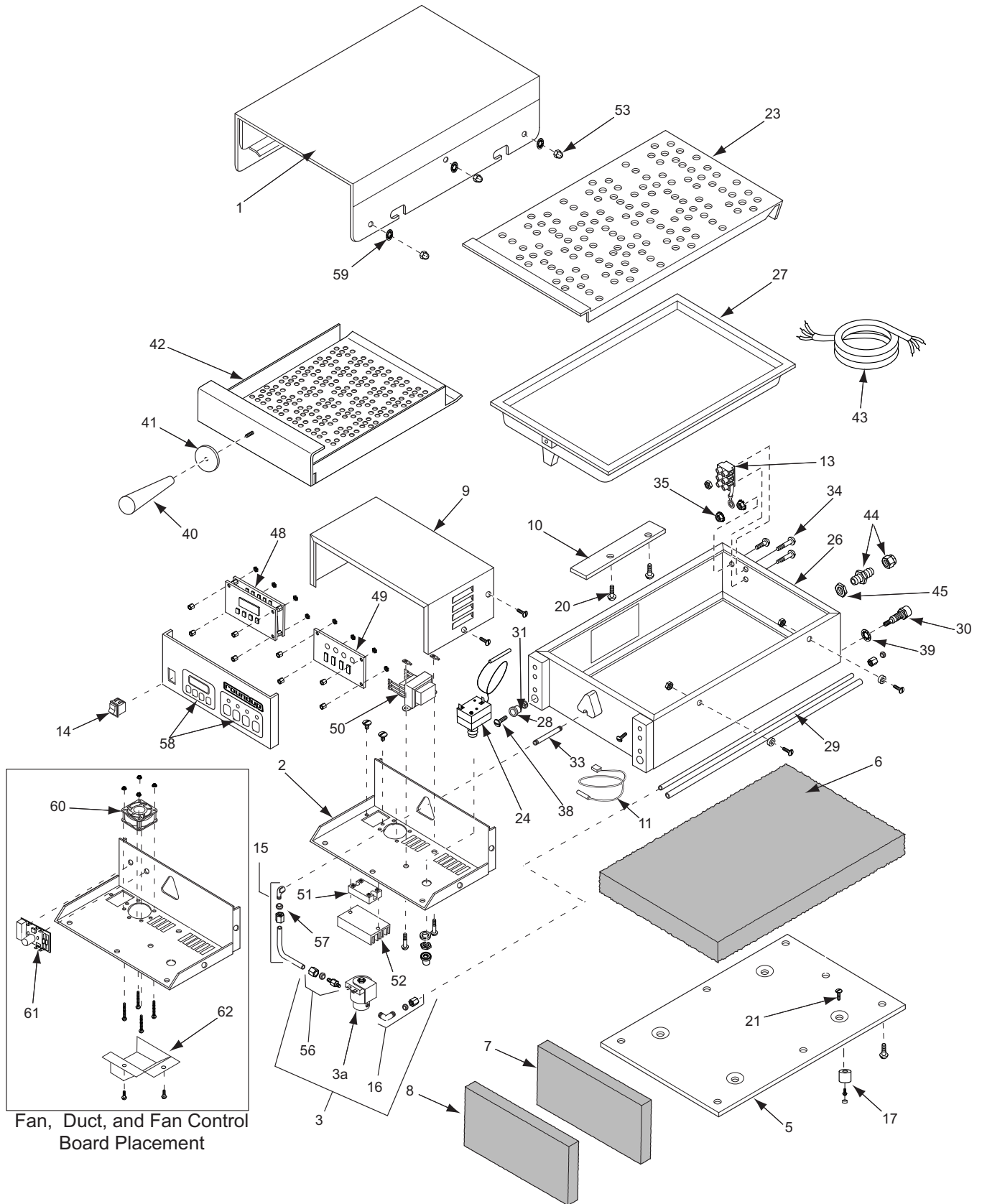

REPLACEMENT PARTS (continued)

| Item | Part No. | Description | Qty. |
|------|----------|---|------|
| 1 | 0011473 | Top Cover Assy. | 1 |
| 2 | 0011327 | Control Housing Assy. | 1 |
| 3 | 0011476 | Solenoid Valve Assy. (Incl. Item# 16 and 56) | 1 |
| 3a | 4040145 | Valve, Solenoid 24 VAC | 1 |
| 4 | 0021222 | Control Panel Weldment | 1 |
| 5 | 0020590 | Base Plate Weldment | 1 |
| 6 | 040K110 | Insulation, Kit (Inlc. #'s 7 & 8.) | 1 |
| 7 | 0400245 | Separator, Insulation | 1 |
| 8 | 0400249 | Insulation, Front | 1 |
| 9 | 0501555 | Cover, Control Housing | 1 |
| 10 | 0501973 | Retainer, Thermocouple Bulb | 1 |
| 11 | 4050209 | Thermocouple, Type K | 1 |
| 12 | 0700599 | Wire Set (not shown) | 1 |
| 13 | 4060304 | Terminal Block, 3-Pole | 1 |
| 14 | 4010137 | Rocker Switch, Power On/Off | 1 |
| 15 | 200K135 | Solenoid Tube Kit | 1 |
| 16 | 2040101 | Male Elbow 184 x 1/8 NPT (see Item #3) | 1 |
| 17 | 210K230 | Bumper, Recess | 4 |
| 18 | 218P145 | Cover, Bumper | 1 |
| 19 | 308P103* | Screw, Machine, #8-32 x 1/4" | 12 |
| 20 | 308P162* | Screw, Machine, #8-32 x 1-1/4" | 2 |
| 21 | 310P136* | Screw, Machine, #10-32 x 1-1/4" | 4 |
| 22 | 325P101* | Stud, 1/4-20 x 1-1/2" | 2 |
| 23 | 0011498 | Diffuser | 2 |
| 24 | 7000272 | Hi-Limit Control | 1 |
| 25 | 4060173 | Cable Tie (not shown) | 6 |
| 26 | 0020719 | Main Housing Weldment | 1 |
| 27 | 7000273 | Generator, 230V/3300W | 1 |
| 28 | 040P119 | Bushing, Shorty, 5/8" | 1 |
| 29 | 200K134 | Inlet Tube Kit | 1 |
| 30 | 208K106 | Body, Quick Disconnect Fitting, 1/4" | 1 |
| 31 | 212P148* | Spacer, Brass (Zinc plated) | 1 |
| 32 | 2140109 | Loctite, #242 (Blue) (not shown) | 1 |
| 33 | 2190101 | Pipe, 1/8" x 2-1/2" | 1 |
| 34 | 306P123* | Screw, Machine, SS, #6-32 x 7/8" | 2 |
| 35 | 306P130* | Nut, Hex, KEPS, Steel (Zinc plated), #6-32 | 2 |
| 36 | 308P104* | Screw, Machine, #8-32 x 3/8" | 4 |
| 37 | 308P124* | Screw, Machine, One-way, #8-32 x 1/2" | 1 |
| 38 | 308P143* | Nut, Hex, KEPS, Steel (Zinc plated), #8-32 | 5 |

| Item | Part No. | Description | Qty. |
|------|----------|---|------|
| 39 | 362P102* | Lockwasher, Internal Tooth, 5/8" | 1 |
| 40 | 2100119 | Handle, Spatula | 1 |
| 41 | 2100118 | Guard, Handle | 1 |
| 42 | 7000290 | Spatula Assy. (incl. #40 & 41) | 1 |
| 43 | 0700606 | Power Cord, Harmonized w/Nema 6-20 Plug | 1 |
| | 0700453 | Power Cord, Harmonized w/CEE 7/7 Schuko Plug | 1 |
| | 0700437 | Power Cord, Harmonized w/IEC-309 Plug | 1 |
| | 0700587 | Power Cord, Harmonized w/ Marechal 16 amp. Pin & Sleeve (Australia only) Mfg. #s 9100336 and 9100346 | 1 |
| | 4060170 | Power Cord, Harmonized w/ L6-20P, 20 Amp., 250 VAC., Straight Twist Lock.. | 1 |
| 44 | 040K251 | Strain Relief | 1 |
| 45 | 040P138 | Locknut, 1/2" | 1 |
| 46 | 0700592 | Wire Harness, Four Channel (not shown) | 1 |
| 47 | 306P134* | Screw, Machine, #6-32 x 3/8" | 2 |
| 48 | 7000294 | Control Board 50/60Hz | 1 |
| | 7000332 | Control Board 50/60Hz (For Mfg #s 9100336 and 9100346 only). | 1 |
| 49 | 4010192 | Four Channel Switch Board | 1 |
| 50 | 4010191 | Transformer | 1 |
| 51 | 7000315 | Solid State Relay | 1 |
| 52 | 4050180 | Heat Sink | 1 |
| 53 | 308P145* | Nut, Hex, Acorn, #8-32 | 6 |
| 54 | 310P136* | Screw, #10-32x1-1/4" | 4 |
| 55 | 210K230 | Bumper Leg Kit (4 included) (Includes #17,18, 54) | 1 |
| 56 | 2040103 | Conn. Male 1/4x1/8"NPT (see Item# 3) | 1 |
| 57 | 204P114 | Female Elbow 1/4" | 1 |
| 58 | 1001055 | Control Panel Label | 1 |
| 59 | 308P186* | Lockwashers | 1 |
| 60 | 4000178 | Fan | 1 |
| 61 | 4070064 | PC Board, DC Fan Power Supply | 1 |
| 62 | 0504035 | Bracket, Fan Duct | 1 |

* Only available in packages of 10.

REPLACEMENT PARTS (continued)

Inlet Hose Assembly P/N 0010503

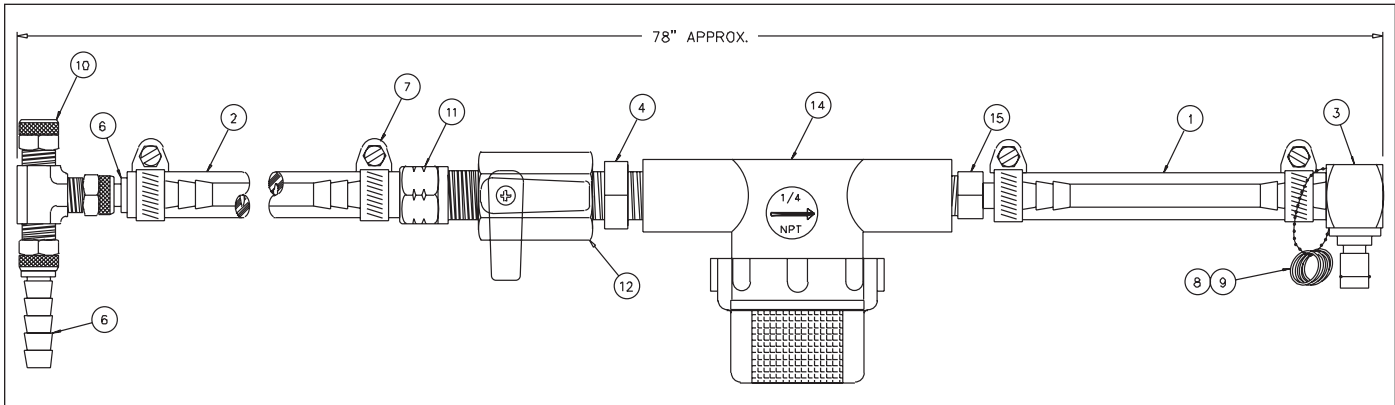

| | | | |
|---|---------|--------------------------------|---|
| 1 | 2030103 | Braided PVC Tubing 4" LG. | 1 |
| 2 | 2030105 | Braided PVC Tubing 66" LG. | 1 |
| 3 | 2080108 | Quick Disconnect Insert (male) | 1 |
| 4 | 2190129 | Nipple 1/4" x 1/4" NPT | 1 |
| 6 | 2040106 | Hose Adapter | 2 |
| 7 | 2110104 | Worm Clamp #U5S | 5 |
| 8 | 0200117 | O- Ring | 4 |

| | | | |
|----|---------|---------------------------------|---|
| 9 | 4060118 | Wire Tie | 1 |
| 10 | 2050103 | Union Tee | 1 |
| 11 | 2040137 | Fitting,-Barb Hose to Fem. Pipe | 1 |
| 12 | 2170108 | Valve, Ball | 1 |
| 14 | 2090127 | Strainer 1/4" FPT | 1 |
| 15 | 2040130 | Male Adapter, Barbed 1/4" | 1 |

OPTIONAL ACCESSORY

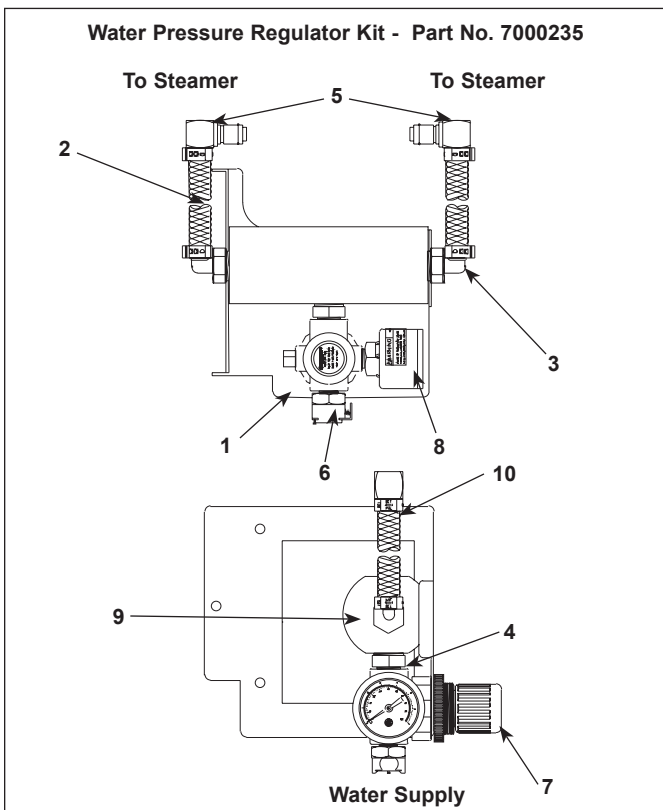

| Item | Part No. | Description | Qty. |
|------|----------|---|------|
| 1 | 0503615 | Bracket, Manifold | 1 |
| 2 | 2030125 | Tubing, 1/4" I.D., PVC, 12" Long | 2 |
| 3 | 2040150 | Elbow, Male, Nylon, 1/4" Barb, 3/8" NPT | 2 |
| 4 | 2040151 | Nipple, Hex, Nylon, 3/8" x 1/4" NPT | 1 |
| 5 | 2080105 | Elbow, Quick Disconnect | 2 |
| 6 | 2080118 | Quick Disconnect, 1/8" NPT | 1 |
| 7 | 2170113 | Regulator, Pressure | 1 |
| 8 | 2170114 | Gauge, Water Pressure | 1 |
| 9 | 2190113 | Manifold | 1 |
| 10 | 2110160 | Clamp | 4 |

IMPORTANT: Two steamer units can be connected into one water pressure regulator.

WIRING DIAGRAM

