

Place this manual in the Toaster section
of your Equipment Manual.

Manufactured exclusively for
McDONALD'S®

BY

A.J. ANTUNES & CO.
180 KEHOE BLVD.

CAROL STREAM, ILLINOIS 60188, U.S.A.

PHONE: 1-630-784-1000

TOLL FREE: 1-877-392-7854

FAX: 1-630-784-1650

www.ajantunes.com



A.J. Antunes & Co.



SS-200 & SS-400

Scan with mobile device or enter URL
for product and service information.

<http://tiny.cc/ajaprodSS>



TABLE OF CONTENTS

| | | | |
|--|----------|--|-----------|
| Owner Information | 2 | Connecting a Water Pressure Regulator..... | 6 |
| General..... | 2 | Operating Instructions | 7 |
| Warranty Information..... | 2 | Programming | 8 |
| Service/Technical Assistance | 2 | Programming the Surface Steamer..... | 8 |
| Specifications | 3 | Factory Resets | 8 |
| Dimensions..... | 3 | Generator Temperature | 8 |
| Electrical Ratings and Plug Configuration..... | 3 | Maintenance | 9 |
| Important Safety Information | 4 | Daily Cleaning | 9 |
| Installation | 5 | Quarterly Cleaning (or as needed)..... | 10 |
| Unpacking..... | 5 | Troubleshooting | 11 |
| Equipment Setup..... | 6 | Replacement Parts | 14 |
| Installing the Surface Steamer | 6 | Wiring Diagrams | 17 |
| | | Notes | 18 |

LIMITED WARRANTY

The Antunes Food Service Equipment Division of A.J. Antunes & Co. provides the following limited warranty to the original purchaser of all McDonald's Equipment. All components are warranted against defects in the material and workmanship for a period of two (2) years from date of original installation.

If any part becomes defective during period of this Warranty, Antunes Food Service will pay negotiated straight time labor costs to an Authorized Service Agent to replace the part, plus travel expenses up to 50 miles/80 km, 1 hour each way (100 miles/160 km, 2 hours round trip).

WARRANTY EXCLUSIONS

- The cost of Installation.
- Equipment that has been damaged due to shipment. Purchaser should make damage claim directly upon carrier.
- Alteration, misuse, abuse.
- Improper storage or handling.
- Improper maintenance.
- Failure to follow proper Installation instructions, including electrical connection.
- Improper or unauthorized repairs.
- Scheduled Maintenance procedures as outlined in your MRC Card.
- This Warranty does not cover Consumable items.
- Water pressure problems or contamination problems such as foreign material in water lines or inside solenoid valves due to an incoming water source.
- Overtime or Holiday charges.
- Mileage over 50 miles/80 km (100 miles/160 km round-trip), or travel time over two (2) hours.
- Freight, foreign, excise, municipal or other sales or use taxes.
- Consequential damages such as loss of profit, loss of time, the cost of repairing or replacing other property which is damaged, or any other incidental damage of any kind.

Antunes Food Service reserves the right to make changes in design or add improvements on any products. The right is always reserved to modify Equipment because of factors beyond our control and government regulation. Changes to Equipment do not constitute a warranty charge.

This warranty is exclusive and is in lieu of all other warranties, expressed or implied, including any implied warranty of merchantability or fitness for a particular purpose, each of which is expressly disclaimed. The remedies described above are exclusive, and in no event shall A.J. Antunes & Co. or any of its Divisions be liable for special consequential or incidental damages for the breach or delay in the performance of this warranty.

This manual is for the exclusive use of licensees and employees of McDonald's Systems, Inc.
© McDonald's Corporation All Rights Reserved

OWNER INFORMATION

General

This manual is produced for the Surface Steamer.

The Surface Steamer is designed for the quick steaming and heating of buns. This design allows the operator to place buns on both sides of Surface Steamer at the same time. Water is superheated into steam, which penetrates the bun to heat it quickly and efficiently.

This manual provides the safety, installation, and operating procedures for the Surface Steamer. We recommend that this manual be read prior to installing and operating the unit.

The Surface Steamer is manufactured from the finest materials available and is assembled to Roundup's strict quality standards. This unit has been tested at the factory to ensure dependable trouble-free operation.

Warranty Information

Please read the full text of the Limited Warranty in this manual. If the unit arrives damaged, contact the carrier immediately and file a damage claim with them. Save all packing materials when filing a claim. Freight damage claims are the responsibility of the purchaser and are not covered under warranty.

SERVICE/TECHNICAL ASSISTANCE

If you experience any problems with the installation or operation of your unit, contact A.J. Antunes & Co. Technical Support at 877-392-7854

Fill in the information below and have it handy when calling your Authorized Service Agency for assistance. The serial number is on the specification plate located on the side of the unit.

Purchased From: _____

Date of Purchase: _____

Model No.: _____

Serial No.: _____

Mfg. No.: _____

Refer to the service agency directory packaged with your manual and fill in the information below:

Authorized Service Agency

Name: _____

Phone No.: _____

Address: _____

Use only genuine Roundup replacement parts in this unit. Use of replacement parts other than those supplied by the manufacturer will void the warranty. Your Authorized Service Agency has been factory trained and has a complete supply of parts for this toaster.

You may also contact the factory at 1-877-392-7854 (North America only), or 630-784-1000 if you have trouble locating your local Authorized Service Agency.

To locate your nearest International Authorized Service Agency: log onto the McDonald's web site: www.mcdonalds.com and follow the on-screen directions.

⚠ WARNING ⚠

ELECTRICAL SHOCK HAZARD. FAILURE TO FOLLOW THE INSTRUCTIONS IN THIS MANUAL COULD RESULT IN SERIOUS INJURY OR DEATH.

- Electrical ground is required on this appliance.
- Do not modify the power supply cord plug. If it does not fit the outlet, have a proper outlet installed by a qualified electrician.
- Do not use an extension cord with this unit.
- Check with a qualified electrician if you are in doubt as to whether the appliance is properly grounded.

⚠ CAUTION ⚠

All electrical connections must be in accordance with local electrical codes and any other applicable codes.

IMPORTANT! Keep these instructions for future reference. If the unit changes ownership, be sure this manual accompanies the equipment.

SPECIFICATIONS

Dimensions

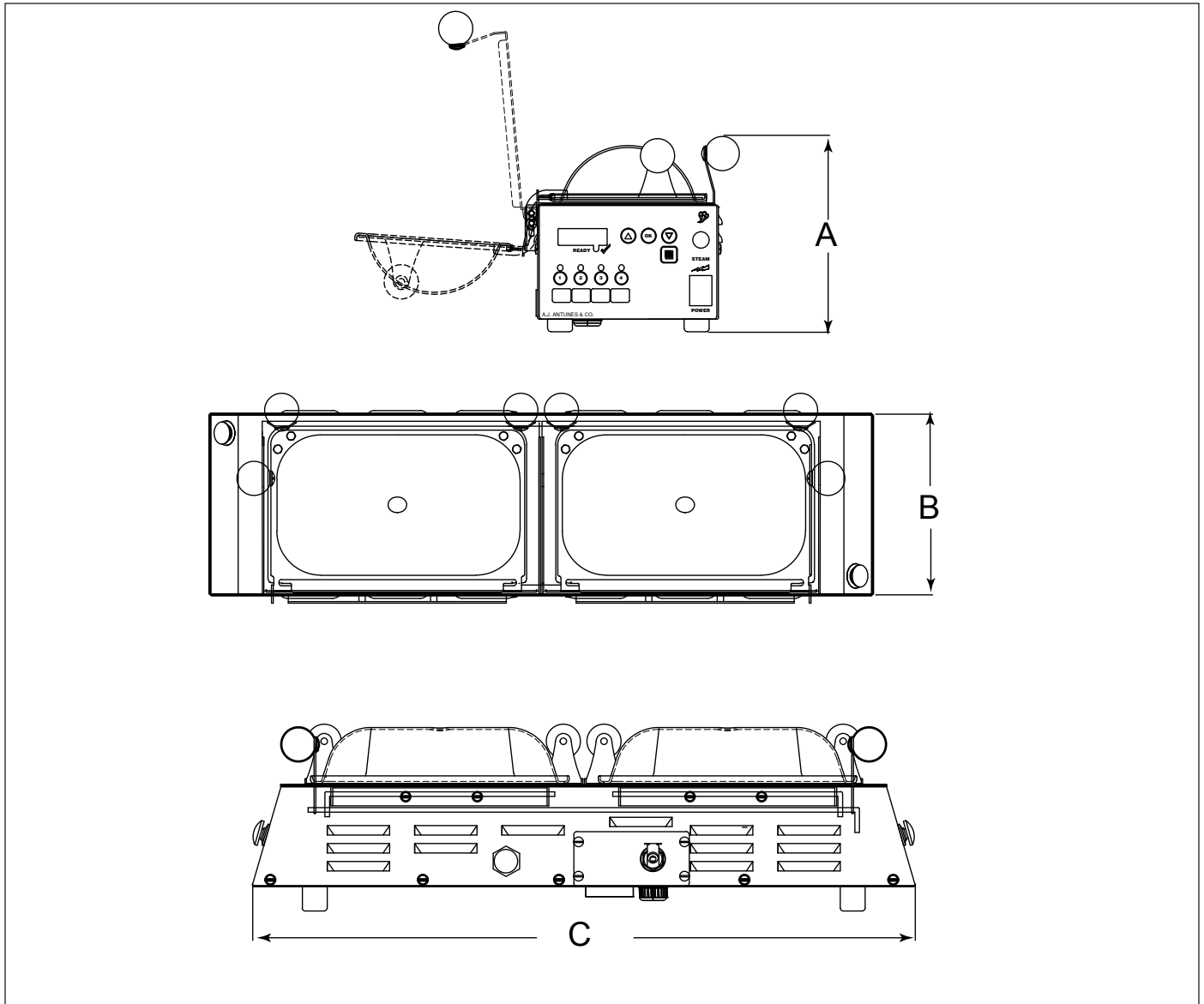



| Model & Mfg. No. | Height (A) | Width (B) | Depth (C) |
|---------------------|-----------------|---------------------|----------------------|
| SS-400TT 9100906 | 8" (20.3 cm) | 7-1/4" (18.4 cm) | 26-7/8" (68.3 cm) |

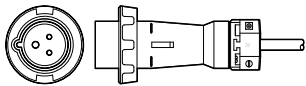

Electrical Ratings and Plug Configuration



| Model & Mfg. No. | Volt | Watts | Amps | Hz | Plug Description | Plug Configuration |
|---------------------|------|-------|------|----|--|---|
| SS-400TT 9100906 | 208 | 4800 | 23.0 | 60 | #330P6W, 30 Amp., 250 VAC., Pin & Sleeve. (P/N 0700482) |  |



IMPORTANT SAFETY INFORMATION



Throughout this manual, you will find the following safety words and symbols that signify important safety issues with regards to operating or maintaining the equipment.

| |
|--|
|  WARNING  |
| <p>GENERAL WARNING. Indicates information important to the proper operation of the equipment. Failure to observe may result in equipment damage and/or severe bodily injury or death.</p> |

| |
|---|
|  WARNING  |
| <p>ELECTRICAL WARNING. Indicates information relating to possible shock hazard. Failure to observe may result in damage to the equipment and/or severe bodily injury or death.</p> |

| |
|--|
|  CAUTION  |
| <p>GENERAL CAUTION. Indicates information important to the proper operation of the equipment. Failure to observe may result in damage to the equipment.</p> |

| |
|---|
|  WARNING  |
| <p>HOT SURFACE WARNING. Indicates information important to the handling of equipment and parts. Failure to observe may result in personal injury.</p> |



| |
|--|
|  WARNING  |
| <p>If the supply cord is damaged, it must be replaced by the manufacturer, its service agent, or a similarly qualified person in order to avoid a hazard.</p> |

In addition to the warnings and cautions in this manual, use the following guidelines for safe operation of the unit:

- Read all instructions before using equipment.
- For your safety, the equipment is furnished with a properly grounded cord connector. Do NOT attempt to defeat the grounded connector.
- Install or locate the equipment only for its intended use as described in this manual. Do NOT use corrosive chemicals in this equipment.
- Do NOT operate this equipment if it has a damaged cord or plug, if it is not working properly, or if it has been damaged or dropped.
- This equipment should be serviced by qualified personnel only. Contact the nearest Authorized Service Agency for adjustment or repair.
- Do NOT block or cover any openings on the unit.
- Do NOT immerse the cord or plug in water.
- Keep cord away from heated surfaces.
- Do NOT allow the cord to hang over edge of table or counter.

The following warnings and cautions appear throughout this manual and should be carefully observed.

- Turn the power off, disconnect the power source, and allow unit to cool down before performing any service or maintenance.
- The procedures in this chapter may include the use of chemical products. These chemical products will be highlighted with bold face letters followed by the abbreviated **HCS** (Hazard Communication Standard). See Hazard Communication Standard manual for the appropriate Material Safety Data Sheets (MSDS).
- The equipment should be grounded according to local electrical codes to prevent the possibility of electrical shock. It requires a grounded receptacle with separate electrical lines, protected by fuses or circuit breaker of the proper rating.

| |
|--|
|  CAUTION  |
| <p>All electrical connections must be in accordance with local electrical codes and any other applicable codes.</p> |

This appliance is not intended for use by persons (including children) with reduced physical, sensory or mental capabilities, or lack of experience and knowledge, unless they have been given supervision or instruction concerning use of the appliance by a person responsible for their safety.

Children should be supervised to ensure that they do not play with the appliance.

INSTALLATION

Unpacking

1. Remove unit and all packing materials from shipping carton.

The main carton should contain one Surface Steamer unit with Water Regulator.

2. Remove all packing materials and protective coverings from the unit and parts.

NOTE: If any parts are missing or damaged, contact A.J. Antunes Technical Service **IMMEDIATELY** at 1-877-392-7854 (North America only), or 630-784-1000.

⚠ CAUTION ⚠

All electrical connections must be in accordance with local electrical codes and any other applicable codes.

⚠ CAUTION ⚠

This equipment is to be installed to comply with the basic plumbing code of the Building Officials and Code Administrators, Inc. (BOCA) and the Food Service Sanitation Manual of the Food and Drug Administration (FDA).

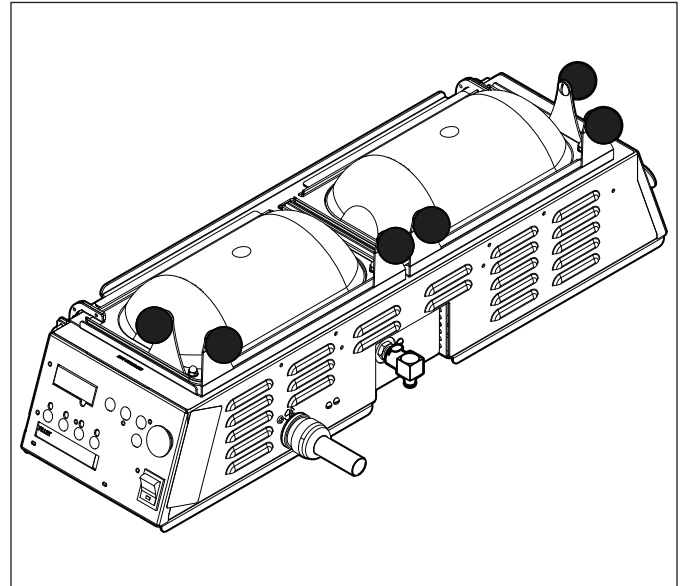
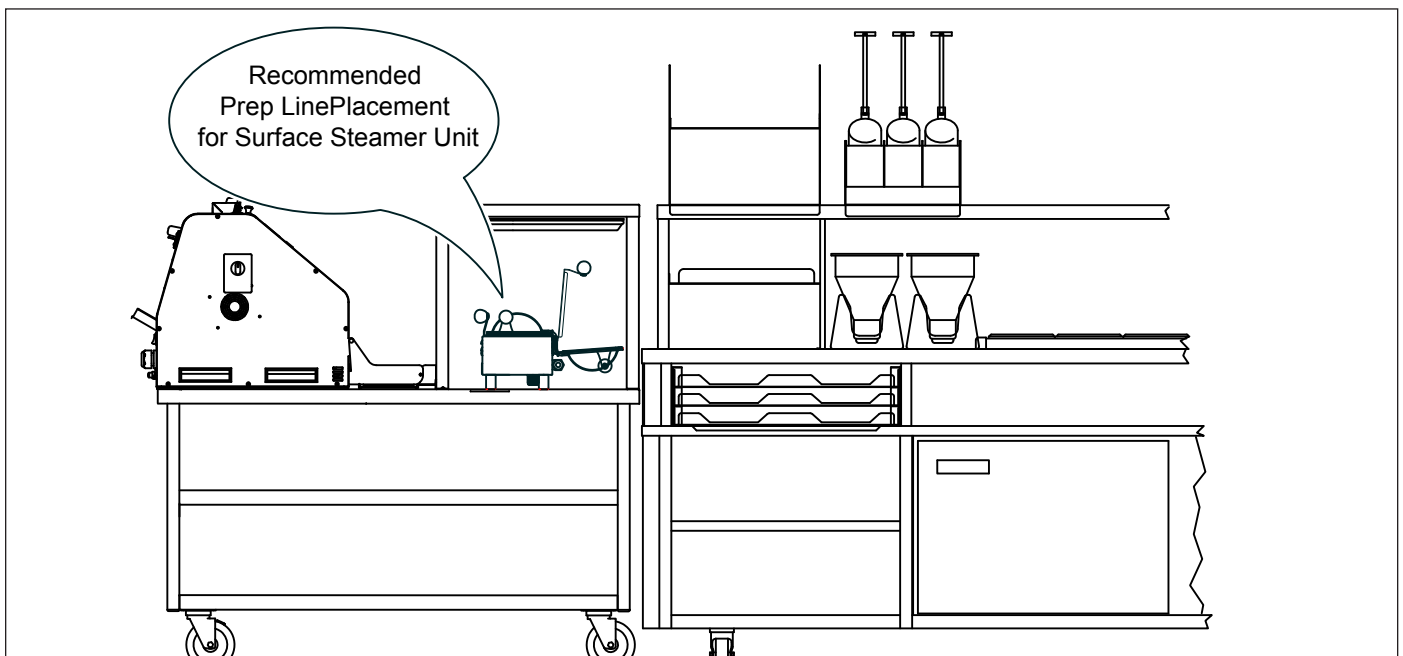

Figure 1. SS-400TT Surface Steamer



INSTALLATION (continued)

Equipment Setup

When placing the steamer into service, pay attention to the following guidelines.

- Make sure power is off and the unit is at room temperature.
- Do NOT block or cover any openings on the unit.
- Do NOT immerse the cord or plug in water.
- Keep the cord away from heated surfaces.
- Do NOT allow the cord to hang over edge of table or counter.

Installing the Surface Steamer

1. Be sure to place the Surface Steamer onto the Prep Surface so that the Bun Cap and Flipper open in the direction of food prep flow.
2. Ensure that the line voltage corresponds to the stated voltage on the unit's specification label and power cord warning tag.
3. Plug the power cord into the appropriate outlet.

NOTE: Route the power cord in a safe manner so that it is out of the way.

Connecting a Water Pressure Regulator

⚠ CAUTION ⚠

Operating pressure should be 8 - 10 psi (55-69 kPa). Higher water pressure may cause poor performance or flooding. It is recommended to use Reverse Osmosis water for better performance of unit and reduced PM

The Surface Steamer includes a Water Pressure Regulator that must be set to 10 psi. Follow these steps to connect the water line to the unit.

NOTE: Use new water hoses sets. Do NOT reuse old water hose sets.

1. Connect the steamer line (Reverse Osmosis) Quick Disconnect to the Water Pressure Regulator.
2. Turn the unit on its side so the Water Pressure Regulator is facing up (Figure 2).
3. Loosen the Locknut counterclockwise (Figure 2), then turn the Water Pressure Adjustment Knob clockwise until the Water Pressure Regulator Gauge reads 10 psi.

4. Once the regulator reads 10 psi, tighten the locknut to lock it in place.
5. Place the unit upright. Turn the power on and allow the unit to warm up.
6. Press the Steam Activation Button a few times to clear the air from the water lines, then run a few steam cycles.
7. Turn the unit off and then place it on its side again so the Water Pressure Regulator Gauge is visible.
8. If the gauge reads 10 psi, the unit is ready for use. Otherwise, adjust the pressure accordingly.

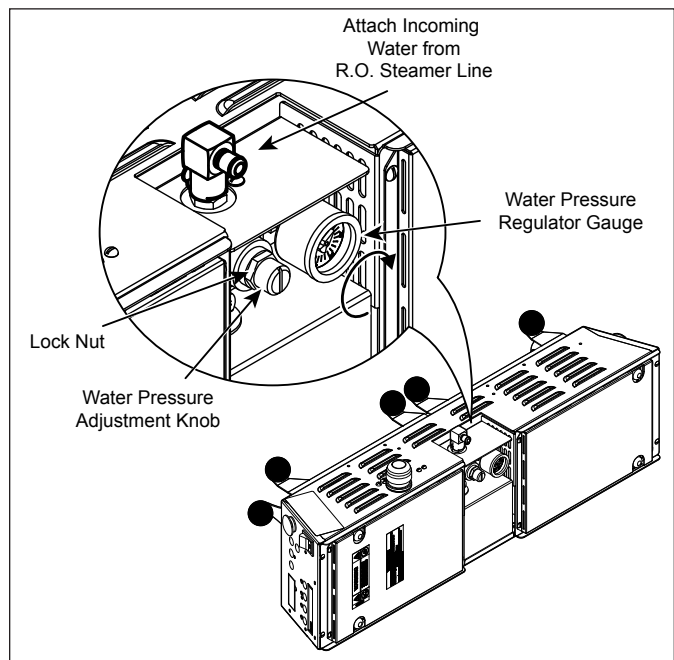

Figure 2. Connecting the Water Pressure Regulator

OPERATION

Operating Instructions

1. Turn the power on and allow the unit to heat up.

NOTE: The display registers “LO” until the preset operating temperature is reached. Once the unit is heated up, the unit displays the cycle time.

2. When the unit is ready, select the desired steam channel by pressing the appropriate button for that channel.
3. Open the Bun Cap and place the heel and crown cut side down onto Flipper. Close the Bun Cap.
4. Press the **ACTIVATION** button to begin a steam cycle. The display counts down to zero and an audio sound signals the end of the cycle.

NOTE: A new cycle cannot be started until the audio signal is finished. To adjust the number of repetitions of the audio signal, see the Programming section of this manual.

4. Open the Bun Cap and then lift the Flipper to remove the buns from the steam area.
5. Complete the assembly of the sandwich.

⚠ CAUTION ⚠

Buns will be hot after steaming! Lift the Flipper to remove buns. Use caution to avoid burns.

NOTE: This unit has two control panels. You can operate the steamer from either side of the unit. However, you can only program the unit and turn it on/off from the Primary Control Panel (Power Switch side).

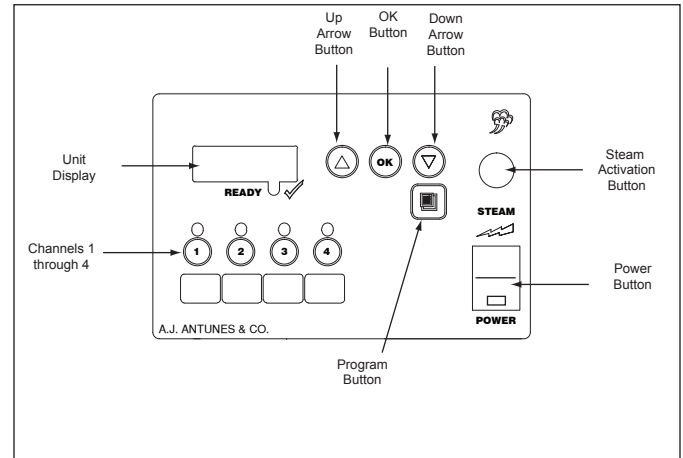

Figure 3. Primary Control Panel View

NOTE: The steamer returns to the default program channel of #1 (See Figure 3) after completing a steam cycle. For example, if you run a steam cycle on channel 4, the steamer returns to channel 1 once the steam cycle completes.

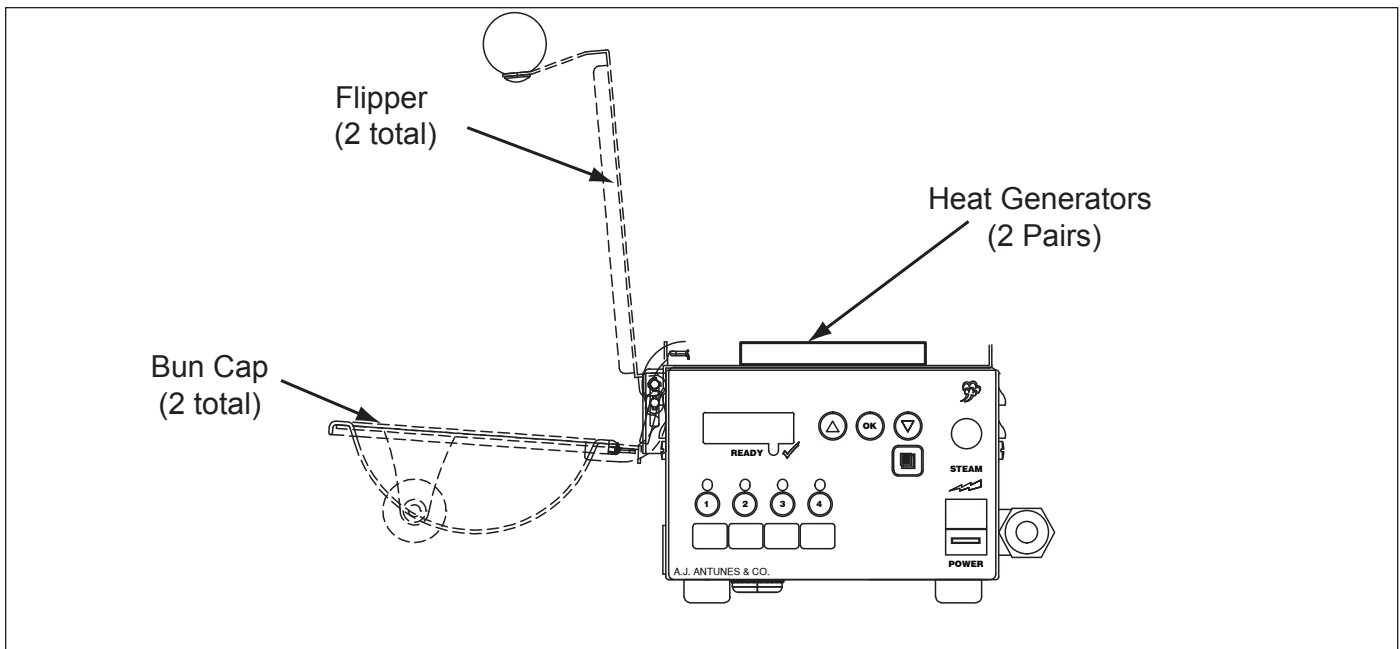

Figure 4. Front View (Primary Control Panel View)

PROGRAMMING

Programming the Surface Steamer

1. Press and hold the **PROGRAM** button until “**CYC**” appears on the display (Figure 5) then release the **PROGRAM** button.
2. Press the **OK** button. The unit displays the currently programmed cycle time.
3. Press the **UP** or **DOWN** arrow buttons to increase or decrease the cycle time in one second increments (from 1 to 60). Release all buttons at the desired setting. Then press the **PROGRAM** button to save changes.

NOTE: To save Programming changes, be sure to press the **PROGRAM** button (Figure 5) as soon as changes are made.

NOTE: During programming mode, the display returns to operation mode after 5 seconds of inactivity.

4. To program values listed in Table 1, repeat Step 1 but press **UP** until the desired value is displayed. Then press **OK** and use the **UP** or **DOWN** arrows to adjust. Press the **PROGRAM** button to save changes, press the **UP** or **DOWN** arrow buttons to move to the next value (Table 1).

Table 1 describes programmable features and parameters of the Surface Steamer: All four steam channels are programmed to these default values at the factory.

Default Values

| Value | Description | Defaults |
|------------------|--|------------|
| CYC | Length of the steam cycle in seconds. Available ranges are from 1 to 60 seconds adjustable in 1 second increments. | 12 seconds |
| SHOT | Regulates the amount of water volume injected at each solenoid valve opening. A higher value equals more water; a lower value equals less water. Available ranges are .05 to 1.00 seconds adjustable in .05 second increments. | 0.20 |
| Intr | Interval - Time between injections of water. Available ranges are 0 to 10 seconds in increments of 1 second. | 4 |
| SETP | Setpoint temperature of the unit. Available ranges are 350°F (176°C) to 400°F (204°C). Increments: 1 | 400 |
| RPT | Repeat - Number of times the audio signal repeats at the conclusion of a steam cycle (1 to 255). Increments: 1 | 2 |
| DEGF/DEGC | Allows the user to select whether the unit displays temperatures in degrees Fahrenheit or Celsius. | DEGF |

Table 1. Programmable Features & Parameters

Factory Resets

Follow these steps to restore the system to the factory preset setting:

1. Turn the power switch **OFF**.
2. Press and hold the **UP** and **DOWN** arrow buttons simultaneously and turn the power switch **ON**.
3. Do not release the buttons until after 3 seconds.

Generator Temperature

To view the actual temperature for the front generators, press and hold the **UP** arrow button.

To view the actual temperature for the rear generators, press and hold the **DOWN** arrow button.

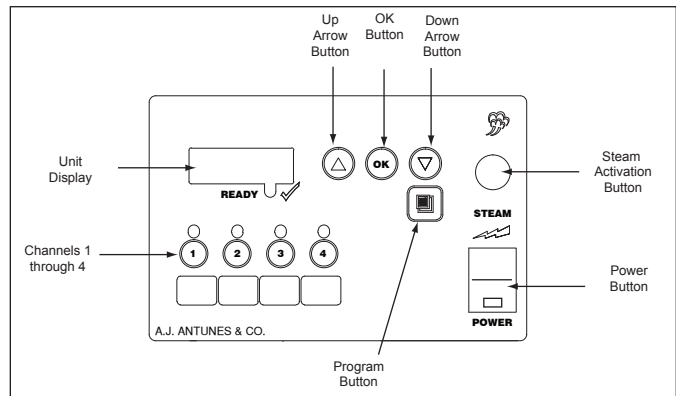

Figure 5. Primary Control Panel View

MAINTENANCE

⚠ WARNING ⚠

Turn the power off, unplug the power cord, and allow the unit to cool down before performing any service or maintenance.

Daily Cleaning

1. **Turn off unit.** Turn the steamer's power switch to the off position. Unplug the power cord from the outlet. Allow the unit to cool down for 30 minutes.

NOTE: Daily Cleaning should be performed after close or during the breakfast menu (for 24-hour stores).

2. **Clean the Bun Caps.** Open the Bun Caps. Clean both sides of the Bun Caps with a clean, sanitized towel sprayed with EXCEED. Wipe the Bun Caps with a clean, sanitized towel sprayed with SolidSense Sanitizer Solution.

NOTE: Do NOT use no-scratch pads or steamer brushes on plastic parts.

3. **Clean the Flipper.** Open the Flipper. Clean both sides of the Flipper with a clean, sanitized towel sprayed with EXCEED. Wipe the Flipper with a clean, sanitized towel sprayed with SolidSense Sanitizer solution. If required, use a no-scratch pad to clean the flipper.
4. **Remove and clean the steamer Heat Shield Pad.** Remove the steamer Heat Shield Pad. Clean one side of the pad with a clean, sanitized towel sprayed with EXCEED. Then wipe the steamer Heat Shield Pad with a clean, sanitized towel sprayed with SolidSense Sanitizer. Repeat this step on the other side of the steamer Heat Shield Pad.

⚠ CAUTION ⚠

Clean the Steam Generators with a damp paper towel only. Do NOT use oily or dirty towels,

5. **Clean the Steam Generators and Diffusers.** Put on neoprene gloves. Remove the diffusers. Clean the Steam Generators with a paper towel dampened with water. Make sure all crumbs and seeds are removed from the generators. Clean the diffusers with a clean, sanitized towel sprayed with EXCEED. Wipe the diffusers with a clean, sanitized towel sprayed with SolidSense Sanitizer.

6. **Clean the top steamer surface.** Wipe the top steamer surface with a clean, sanitized towel sprayed with EXCEED. Wipe the top steamer surface with a clean, sanitized towel sprayed with SolidSense Sanitizer.
7. **Clean outside of steamer.** Wipe the entire outside of the steamer with a clean, sanitized towel sprayed with EXCEED. Wipe the entire outside of the steamer with a clean, sanitized towel sprayed with SolidSense Sanitizer.
8. **Install the steamer Heat Shield Pad and Diffusers.** Place the steamer Heat Shield Pad on top of the steamer, reversing sides. Place the Diffusers into the Steam Generators.
9. **Close the Flipper and Bun Caps.** Close the Flipper and Bun Caps.

QUICK RECOVERY FOR POOR STEAM OUTPUT DURING USE

The SS-400TT uses an open Heat/Steam Generator. Water sprayed onto the Generator surface flashes into steam immediately, but the minerals in the water stay on the Generator surface. A small amount of mineral deposits are needed for proper operation, but excessive deposits cause poor steaming efficiency and excessive moisture, which eventually hinders the steam action.

If the unit is not steaming correctly, follow this procedure to improve steaming quality.

1. Pour 59 ml (2 ounces) of tap water into a clean beverage cup.
2. Pour the water into both Steam Generators and let it boil off.

NOTE: If needed, repeat steps 1 and 2 a few times.

This should result in a fine covering of minerals on the steam generator.

MAINTENANCE (continued)

Quarterly Cleaning (or as needed)

Check the steamer each quarter to ensure the generators are properly seasoned and the unit is operating correctly. Over time, product spills may hinder steaming. Follow these steps to ensure the steamer is working properly.

1. **Check for proper operation.** Turn the unit on and let it warm up. Steam 2 or 4 buns. If the unit steams the buns correctly, you do not need to continue. If the buns are not steamed correctly, continue with this procedure.
2. **Turn off unit.** Turn the steamer's power switch to the off position. Unplug the power cord from the outlet. Allow the steamer to cool for at least 30 minutes.
3. **Open the Bun Caps, Flipper, and remove the steamer Heat Shield Pad.** Open the Bun Caps and Flipper. Remove the Steamer Heat Shield Pad. Replace the Heat Shield Pad if torn.
4. **Wipe down the steam generators.** Put on neoprene gloves. Remove the diffusers. Wipe the Steam Generators with a paper towel dampened with water. Be sure to remove all crumbs and seeds from the steam Generator.
5. **Turn the unit on.** Plug the power cord into the outlet. Turn the unit on and let it warm up.
6. **Season the Steam Generators if too Silver.** Fill a clean beverage cup or any clean container with tap water. Put on neoprene gloves carefully pour a small amount of the water into the steam generators. Allow the water to boil off. Do not press any buttons. Repeat this step as needed.

NOTE: The water heats up quickly as it boils off. Use caution.

7. **Test the unit.** Press the activation button to run a steam cycle. If the unit does not steam correctly, repeat steps 6 and 7. If the unit still does not steam correctly, contact your Authorized Service Agency. Turn the unit off when there is no more water in the Steam Generators.

8. **Turn off unit.** Turn the unit off when there is no more water in the steam generators.

NOTE: Once seasoned, the steam generators will have a thin covering of minerals. This is required for proper steaming.

9. **Wipe down the unit.** Put on neoprene gloves. Wipe down the top steam surface and entire exterior of the unit with a clean, sanitized towel.
10. **Install the steamer Heat Shield Pad and Diffusers.** Place the steamer Heat Shield Pad on the top of the steamer, reversing sides. Place the diffusers in the generators.
11. **Close the Flipper and Bun Caps.** Close the Flipper and Bun Caps.

Cleaning the Water Inlet Tube(s)

Follow this procedure as needed if the Water Inlet Tubes become clogged.

1. With the unit cool, insert a straightened paper clip into the Water Inlet Tube opening no more than 1 1/2 inches deep (Figure 6).
2. Turn the unit on and allow it to warm up.
3. Run two or three steam cycles to force out any obstructions from the tube.
4. Repeat steps 1 through 3 as needed.

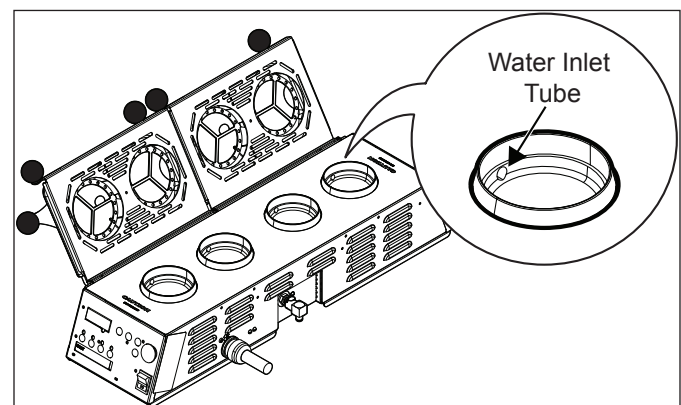

Figure 6. Water Inlet Tube

TROUBLESHOOTING

⚠WARNING⚠

To avoid possible personal injury and/or damage to the unit, inspection, test and repair of electrical equipment should be performed by qualified service personnel. The unit should be unplugged when servicing, except when electrical tests are required.

If the troubleshooting steps listed do not solve your machine problem, contact an Authorized Service Agency for further assistance or service.

| Problem | Possible Cause | Corrective Action |
|---|---|---|
| Control Display is blank (Power Switch is in the On position but indicator light is off). | The power cord is not correctly plugged in. | Plug the power cord into the appropriate outlet. |
| | The power cord and/or electrical plug is damaged. | Inspect electrical wire, plug, and receptacle. |
| | The main electrical panel circuit breaker is off or is tripped. | Reset circuit breaker. Contact your maintenance person or Authorized Service Agency if it trips again. |
| | Power Switch is inoperable. | Contact your maintenance person or Authorized Service Agency for service. |
| Unit does not heat up (Power Switch is in the On position and the indicator light is on). | Hi-Limit Thermostat is tripped or inoperable. | Contact your maintenance person or Authorized Service Agency for service. |
| | Solid State Relay is inoperable. | |
| | Thermocouple is inoperable. | |
| | Main Control Board is inoperable. | |
| | Steam Generator is inoperable. | |
| | Loose, burnt, or broken wires in heat circuit. | |
| Main electrical panel circuit breakers trips. | Damaged receptacle, plug, or cord or a loose connection or an internal component failure. | Contact your maintenance person or Authorized Service Agency if the condition repeats. |
| | Circuit breaker is overloaded. | |
| Water leaking inside electrical housing. | Pinhole leak in rubber hoses. | Replace hoses. |
| | Loose or damaged water line tubes and/or fittings inside electrical housing. | Tighten or replace tubes and/or fittings. |
| Water leaking at Water Pressure Regulator. | The O-rings are damaged. | Replace O-ring. |
| "Hi" appears on the display. | If this occurs during heavy use, the unit is not getting enough water pressure. | Check and adjust the water pressure regulator to 10 psi and adjust and reprogram values back to factory settings. See "Factory Resets." |
| | Pinched/kinked internal water lines or clogged injection tube. | Check for kinked water lines and clogs. |
| | Inoperable Solid State Relay. | Contact your maintenance person or Authorized Service Agency for service. |
| | Inoperable Main Control Board. | |

TROUBLESHOOTING (continued)

| Problem | Possible Cause | Corrective Action |
|---|--|---|
| Unit heats but there is little or no steam produced and/or The product requires more steaming than usual. | Water Line Valve is closed. | Check that the Water Line Valve is open. |
| | Water injection tube is restricted. | Check and clean the Injection Tube as described in the Maintenance section of this manual. |
| | Quick Disconnect Fittings are not fully engaged at the Water Pressure Regulator. | Remove and re-engage the Quick Disconnect Fittings firmly until it clicks into place. Replace if damaged. |
| | Low or no water pressure in the water line. | If pressure is low, contact your maintenance person or plumber. Check incoming water line for water pressure. |
| | Improper water pressure to unit. | Verify that a Water Pressure Regulator is installed and set to 10 psi. |
| | Unit is not being cleaned properly (daily/monthly). | Clean the unit daily and monthly as described in the Maintenance section of this manual. |
| | Programming and/or SHOT , Intr values were adjusted/ changed improperly. | Reprogram the SHOT and Intr values as described in the Programming section of this manual. See "Factory Resets." |
| | Insufficient or excessive calcium/mineral deposits on the Generator surface. | Verify that a thin layer of calcium/mineral deposits is present on the Generator surface. Refer to the Maintenance section of this manual. |
| | Generator surface is bare (little or no traces of mineral deposits). | The Generator surface must have a thin coating of calcium/mineral deposits for proper steaming. Refer to the Maintenance section of this manual. |
| | The internal rubber hoses are pinched or kinked. | Straighten and reposition the rubber hoses. |
| | Generator Diffusers are missing. | Install Generator Diffuser or replace if missing. |
| | Generator surface temperature is too low. | Verify that the Generator set point temperature is 400°F (204°C). See "Factory Resets." |
| "Lo" appears on the display during operation. | Water Pressure is too high and/or out of range. | Adjust the water pressure to 10 psi and reprogram values back to factory settings. See "Factory Resets." |
| | Normal for several minutes during heat up period. | Wait 10 minutes. If "Lo" is still displayed, adjust the water pressure to 10 psi and reprogram values back to factory settings. See "Factory Resets." If "Lo" is still displayed, contact your maintenance person or Authorized Service Agency for service. |
| "HOT" appears on the display during operation. | The temperature inside the electrical compartment is above 160°F (71°C). | Make sure there is enough air flow around the unit. Relocate the unit if necessary. |
| | | Verify that the Insulation and Heat Shield are installed correctly around the heat/steam generators (items 22 and 23 in the "Replacement Parts" section). |
| "OPEN" appears on the display during operation. | The front and/or rear thermocouple is disconnected or open. | Contact your maintenance person or Authorized Service Agency if the condition repeats. |
| | Faulty main Control Board. | |

TROUBLESHOOTING (continued)

| Problem | Possible Cause | Corrective Action |
|--|---|--|
| Excessive condensation in Food Compartment. | Water pressure is too high. | Verify that the Water Pressure Regulator is set to 10 psi. Adjust accordingly. |
| | Programming and or SHOT and Intr values were adjusted improperly (Timer Models only). | Reprogram the SHO and H2O values as described in the Programming section of this manual to factory settings. See "Factory Resets." |
| Excessive Steam escapes from front or sides of steamer. | Worn or damaged Bun Caps. | Replace Bun Caps. |
| Steam Generator's surface becomes flooded (fills with excess water). | Water Pressure Regulator is faulty or not properly installed. | Verify that a Water Pressure Regulator is installed and set to 10 psi. Adjust accordingly or replace. |
| | Programming and/or the SHO value was adjusted or changed improperly. | Reprogram the Control Board to the recommended settings. Refer to the Programming section of this manual. See "Factory Resets." |
| | Solenoid Valve is leaking due to debris trapped inside the plunger. | Attempt to flush the debris out of the valve by operating the unit on a number of cycles and then letting it rest. If the unit still leaks, disassemble the Solenoid Valve and clean out the plunger. Reassemble the unit and test again. If a leak is still present, replace the Solenoid Valves. Contact your maintenance person or Authorized Service Agency. |
| | Improper Daily/Monthly cleaning. | Follow the Daily/Monthly cleaning procedures carefully. |
| | The Generator surface temperature is too low. | Verify that the Generator set point temperature is between 400°F (204°C). See "Factory Resets." |
| | Insufficient or excessive calcium/mineral deposits on the Generator surface. | Verify that a thin layer of calcium/mineral deposits is present on the Generator surface. Refer to the Maintenance section of this manual. |
| | Solenoid Valve is installed incorrectly. | If the Solenoid Valve was replaced, verify that the "IN" and "OUT" labels on the valve correspond to the water flow. |

REPLACEMENT PARTS

| Item | Part No. | Description | Qty. |
|------|----------|---|------|
| 1 | 306P152* | Nut, Acorn #6-32 Low Crown w/ Center Lock | 1 |
| 2 | 306P162* | Washer - Flat #6 | 4 |
| 3 | 0021672 | Bun Cap Frame Weldment | 1 |
| 4 | 2100138 | Knob, Ball | 6 |
| 5 | 2180301 | Bun Cap with Ribs | 2 |
| 6 | 306P125* | Screw, Mach #6-32 x 3/8" | 4 |
| 7 | 0012520 | Bun Cap Assembly SS-400TT | 1 |
| 8 | 0800417 | Rod, Pivot | 2 |
| 9 | 325P132* | Screw, Mach 1/4-20 x 1/2" | 2 |
| 10 | 0021673 | Weldment, Flipper (Primary Side) | 1 |
| 10a | 0021686 | Weldment, Flipper (Secondary Side) | 1 |
| 11 | 0400407 | Heat Shield Pad, SS-400TT | 1 |
| 12 | 0400411 | Insulation, Fiberglass | 1 |
| 13 | 212P168* | Spacer, #6 | 8 |
| 14 | 040P119* | Bushing, Shorty 5/8" | 3 |
| 15 | 0506022 | Heat Shield | 1 |
| 16 | 040P265* | Bushing, Shorty 3/8" | 1 |
| 17 | 0012503 | Diffuser Assembly | 4 |
| 18 | 7000927 | Generator Kit | 2 |
| 19 | 4051008 | Thermocouple Type K (open end) Primary Side | 1 |
| 20 | 4050214 | Thermocouple Type K Open ended Secondary Side | 1 |
| 21 | 4030404 | Thermostat, 1/2" Disc 500 F Auto Reset | 2 |
| 22 | 0400412 | Insulation, Bottom | 1 |
| 23 | 0012519 | Heat Shield Cover Assembly | 1 |
| 24 | 308P103* | Screw, Mach #08-32 x 1/4 | 4 |
| 25 | 304P114* | Screw, Mach #4-40 x 1/4" | 1 |
| 26 | 0506038 | Bracket, Display | 2 |

| Item | Part No. | Description | Qty. |
|------|----------|---|------|
| 27 | 1001369 | Label, Filet | 1 |
| 28 | 0012522 | Solenoid Valve Assembly | 1 |
| 29 | 308P144* | Screw, Mach #8-32 x 1/4" w/ #6 Head | 1 |
| 30 | 4010215 | Momentary Switch Assembly (Rear) | 1 |
| 31 | 4070148 | Rear Board, Surface Steamer | 1 |
| 32 | 0012523 | Water Pressure Regulator Assembly | 1 |
| 33 | 0400375 | Strain Relief Cord Connector | 1 |
| 34 | 4010239 | Momentary Switch Assembly (Front) | 1 |
| 35 | 7000542 | Rocker Switch with Green Indicator | 1 |
| 36 | 4070147 | Front Board, Surface Steamer | 1 |
| 37 | 304P105* | Nut, Hex "KEPS" #4-40 Zinc | 1 |
| 38 | 040P376* | Lock-Nut, Conduit 3/4" NPT | 1 |
| 39 | 306P101* | Nux, Hex #6-32 | 1 |
| 40 | 4060304 | Terminal Block, 3 Pole | 1 |
| 41 | 306P123* | Screw RHMS #6-32 x 7/8 | 1 |
| 42 | 7000463 | Power Cord Assembly | 1 |
| 43 | 4070106 | 25 Amp Switch Relay Board | 1 |
| 44 | 0021671 | Relay Bracket Weldment | 1 |
| 45 | 4050240 | Relay, Solid State Dual Pole w/ Conn Recept, | 1 |
| 46 | 7000979 | Control Board Replacement Kit SS-200TT/SS-400TT | 1 |
| 47 | 0021670 | Bottom Plate Weldment, Secondary side | 1 |
| 48 | 0021669 | Bottom Plate Weldment Primary Side | 1 |
| 49 | 306P104* | Screw, Mach #06-32 x 1/4 SLTRSHD; 304 S/S; BRT | 1 |
| 50 | 0506045 | False Bottom Plate, Primary Side | 1 |
| 51 | 0506047 | False Bottom Plate, Sec. Side | 1 |
| 52 | 7000436* | Rubber Head Screw Bumper | 4 |

* Sold only as packages of 10

REPLACEMENT PARTS (continued)

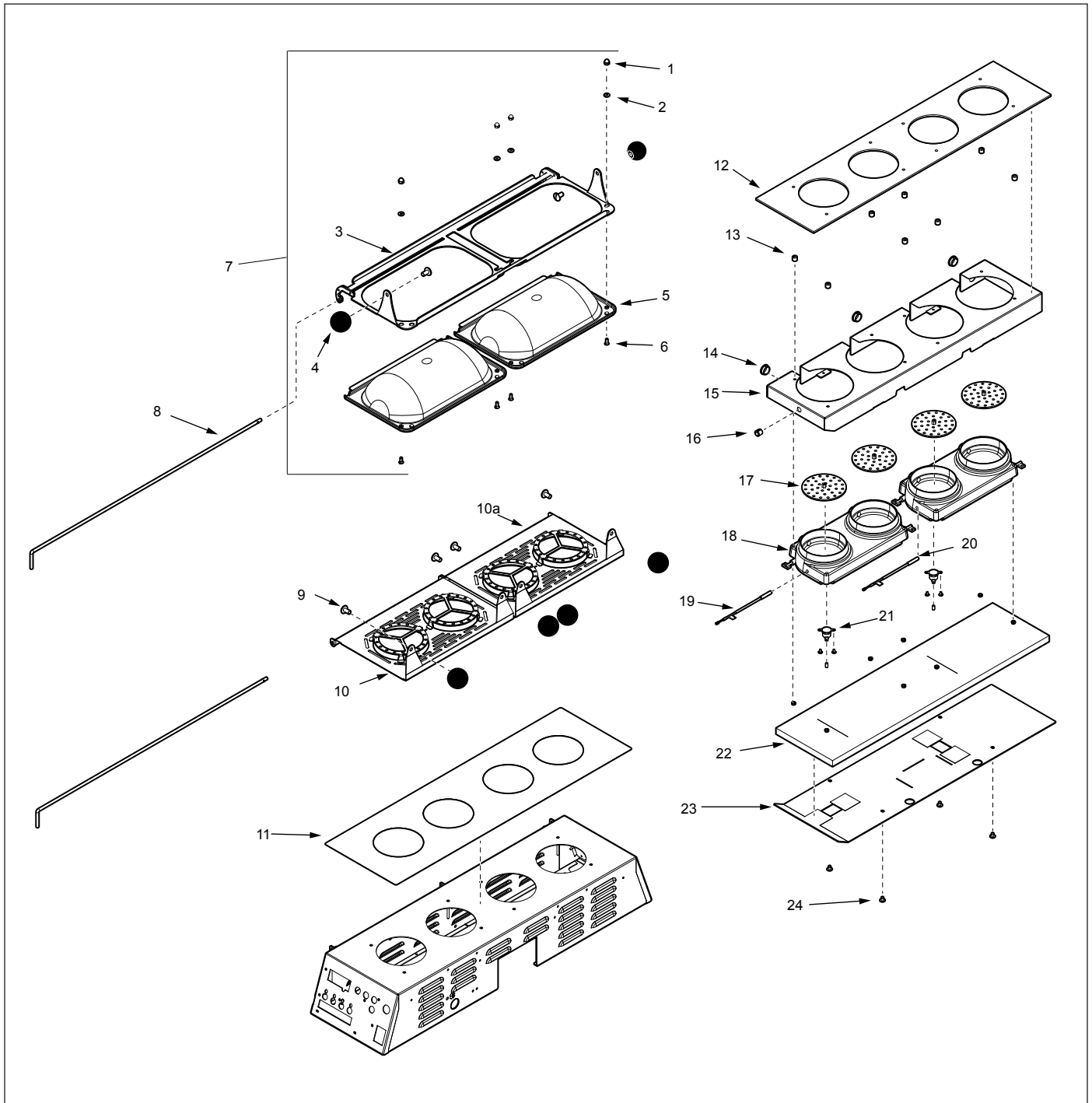

REPLACEMENT PARTS (continued)

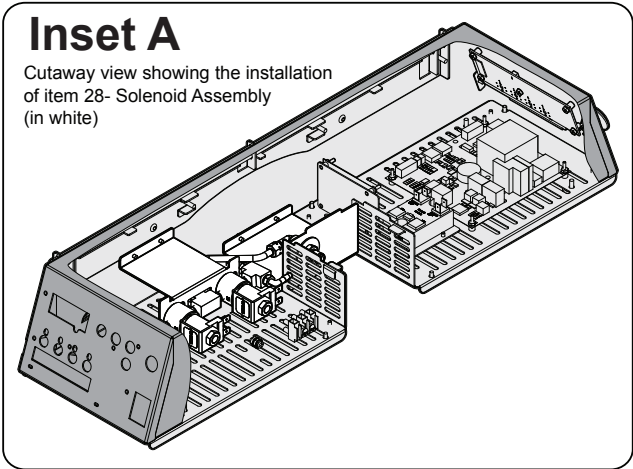
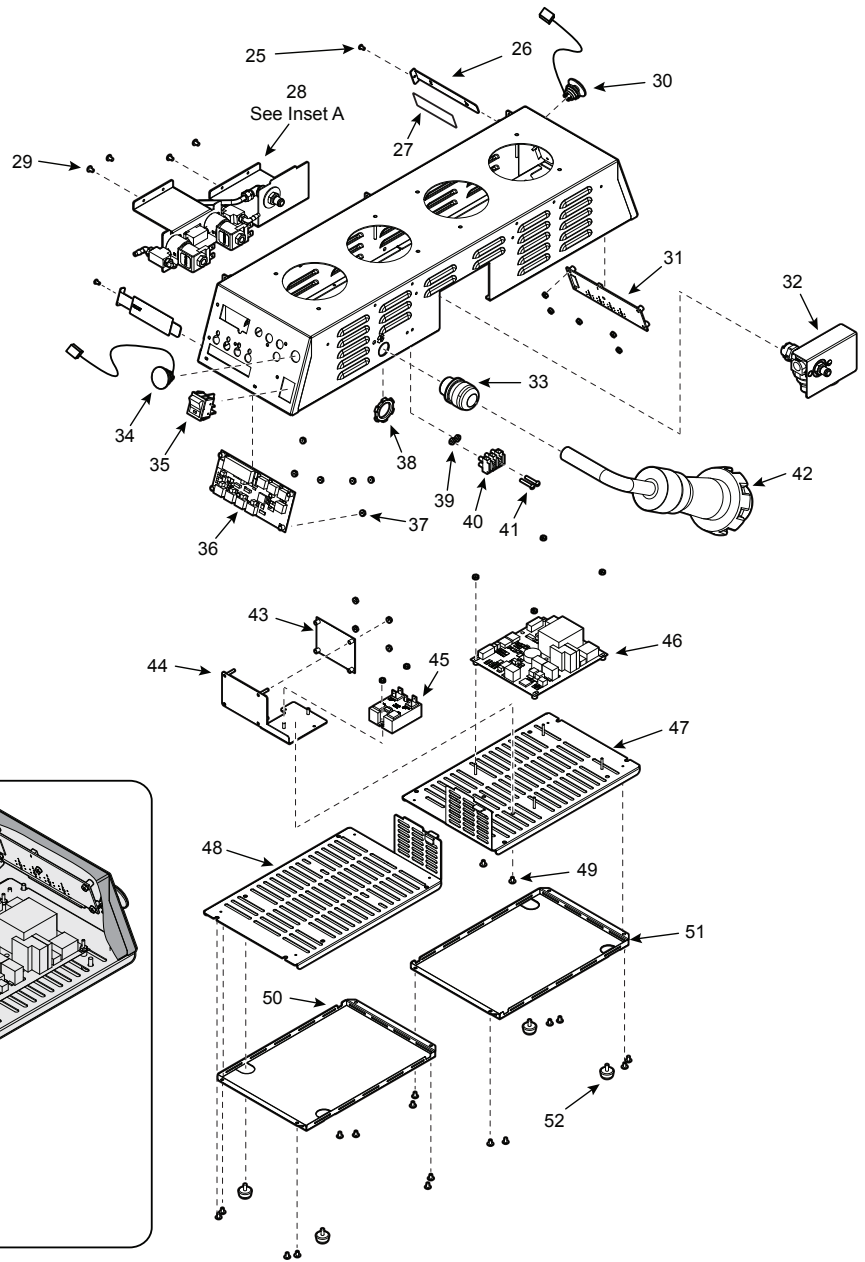



A.J. Antunes & Co.
We exist to make our customers successful.

A.J. Antunes & Co.
Headquarters/Manufacturing
Carol Stream, Illinois 60188 USA
Phone: 630-784-1000
Toll Free: 800-253-2991
Fax: 630-784-1650

**Antunes Equipment
Manufacturing (Suzhou) Ltd.,**
Suzhou, Jiangsu, China 215011
Phone: 86-512-6841-3637
Fax: 86-512-6841-3907

www.AJAntunes.com