

MANUFACTURING  
NUMBERS:

9700700  
9700701  
9700830  
9700831  
9700840  
9700850  
9700851



Antunes Filtration Technologies

# **TOTAL ASSURANCE PACKAGE**

## **TAP-44X Family**



Cartridge Tested and Certified by NSF  
International against NSF/ANSI  
Standard 42 and 53 for the reduction of:

Standard No. 42: Aesthetic Effects  
Nominal Particulate Reduction Class I  
Standard No. 53: Health Effects  
Cyst Reduction  
Turbidity Reduction.



P/N 1010942 Rev. E 03/09



*TAP-442 shown*

# **Owner's Manual**

## TABLE OF CONTENTS

<b>Owner Information</b> .....	<b>2</b>	Attaching to the System Inlet .....	15
General .....	2	Attaching to the Filtered Water Permeate Outlet ....	15
Warranty Information .....	2	Starting the System .....	15
Service/Technical Assistance .....	3	Rinsing the Ultra Filtration Cartridge .....	16
<b>Important Safety Information</b> .....	<b>3</b>	Sanitizing the System and Lines .....	17
<b>Specifications</b> .....	<b>5</b>	Rinsing the Carbon Elements and Plumbing .....	17
Dimensions .....	5	<b>Operation</b> .....	<b>18</b>
Electrical Cord & Plug Configurations .....	5	Operation .....	18
Operating Weights .....	5	Manual Flushing .....	18
Replacement Cartridges .....	5	System Power Loss .....	18
<b>Performance Data Sheet</b> .....	<b>8</b>	Viewing Filtration Element Data .....	18
Filter Cartridge Capacities .....	8	Viewing Sensor Readings .....	18
System Capacities .....	8	Replacing the Carbon Element .....	19
Performance Claims for Percent Reduction .....	8	<b>Maintenance</b> .....	<b>19</b>
<b>Water Condition Equipment Guidelines</b> .....	<b>8</b>	Resetting the Carbon Element Accumulated Total Value .....	20
<b>Installation</b> .....	<b>9</b>	Replacing the Ultra Filtration Cartridge .....	20
System Overview .....	9	System Sanitization .....	21
Unpacking (TAP-441/442) .....	9	Accessing TAP Controller Features.....	22
Unpacking (TAP-440) .....	9	Service Menu Access .....	23
Equipment Setup .....	10	<b>Troubleshooting</b> .....	<b>24</b>
Installing a Bypass .....	12	<b>Wiring Diagram</b> .....	<b>26</b>
Mounting the System.....	12	<b>Recommended Equipment Schematic</b> .....	<b>26</b>
Check Valve Assembly .....	14	<b>Replacement Parts</b> .....	<b>27</b>
Drain Hose Connection .....	14	<b>Limited Warranty</b> .....	<b>Back Cover</b>
Rinse Hose Connection.....	14		

## OWNER INFORMATION

### General

The TAP Family is an innovative filtration system that uses NeoH capillary membranes as well as carbon element to provide the latest innovation in filtration technology.

This manual provides the safety, installation, and operating procedures for the TAP Family water filtration systems. We recommend that all information contained in this manual be read prior to installing and operating the system. Your TAP Family system is manufactured from the finest materials available and is assembled to AFT's strict quality standards. This system has been tested at the factory to ensure dependable trouble-free operation.

### Warranty Information

Please read the full text of the Limited Warranty in this manual.

If the system arrives damaged, contact the carrier immediately and file a damage claim with them. Save all packing materials when filing a claim. Freight damage claims are the responsibility of the purchaser and are not covered under warranty.

The warranty **does not** extend to:

- Damages caused in shipment or damage as result of improper use.
- Installation of electrical service.
- Normal maintenance as outlined in this manual.
- Malfunction resulting from improper maintenance.
- Damage from moisture leaking into electrical components.
- Normal maintenance as outlined in this manual.
- Damage from tampering with, removal of, or changing any preset control or safety device.

**IMPORTANT! Keep these instructions for future reference. If the system changes ownership, be sure this manual accompanies the equipment.**

## OWNER INFORMATION (continued)

### Service/Technical Assistance

If you experience any problems with the installation or operation of your system, contact Antunes Filtration Technologies at **1-630-784-1000**, or toll free in the United States at **1-800-253-2991**.

Fill in the information in the next column and have it handy when calling for assistance. The serial number is on the specification plate located on the system.

Purchased From: \_\_\_\_\_

Date of Purchase: \_\_\_\_\_

Model No.: \_\_\_\_\_

Serial No.: \_\_\_\_\_

Mfg. No.: \_\_\_\_\_

## IMPORTANT

**A.J. Antunes and Company reserves the right to change specifications and product design without notice. Such revisions do NOT entitle the buyer to corresponding changes, improvements, additions, or replacements for previously purchased equipment.**

## IMPORTANT SAFETY INFORMATION

In addition to the warnings and cautions in this manual, use the following guidelines for safe operation of the system.

- Read all instructions before using equipment.
- Install or locate the equipment only for its intended use as described in this manual. Do NOT use corrosive chemicals in this equipment.
- Do NOT operate this equipment if it has a damaged cord or plug; if it is not working properly, or if it has been damaged or dropped.
- This equipment should be serviced by qualified personnel only. Contact your nearest Authorized Service Agency or Authorized Beverage Installer in the area.
- Do NOT immerse cord or plug in water.
- System should only be supplied with cold water.
- Keep cord away from heated surfaces.
- For installations in Massachusetts, the Commonwealth of Massachusetts Plumbing Code 248 CMR shall be adhered to. The use of saddle valves are not permitted. Please consult your local plumber.
- The TAP system is NOT designed to be used in pharmaceutical or medical applications where pyrogen- and endotoxin-free water is necessary.

The following warnings and cautions appear throughout this manual and should be carefully observed.

- Disconnect the power source before performing any service or maintenance on the system.
- All electrical connections must be in accordance with local electrical codes and any other applicable codes.
- **WARNING ELECTRICAL SHOCK HAZARD. FAILURE TO FOLLOW THESE INSTRUCTIONS COULD RESULT IN SERIOUS INJURY OR DEATH.**
  - Do NOT modify the power supply cord plug. If it does not fit the outlet, have a proper outlet installed by a qualified electrician.
  - Do NOT use an extension cord with this appliance.
- If the supply cord is damaged, it must be replaced by the manufacturer or its service agent or a similarly qualified person.
- This equipment is to be installed to comply with the local plumbing code and any other applicable code.
- Water pressure must not exceed 100 psig (690 kPa). To reduce water pressure, install a water pressure regulator and set to suit the application. Also, the trans membrane pressure (inlet pressure minus the permeate water pressure) must not exceed 45 psi (310 kPa).

## IMPORTANT SAFETY INFORMATION (continued)

### Protect from becoming dry

If the membrane dries out, irreversible damage to the membrane may result. Protect the filter from becoming dry by keeping it wet and sealed at all times.

### Protect from freezing

If the membrane freezes during operation or storage, irreversible damage to the membrane and brittle cracking of the cartridge or housing may result.

### Protect from direct sunlight or other UV sources

Avoid long-term exposure to direct sunlight or other UV sources. The filter should be stored in a dark location.

### Protect from high temperatures or abrupt variation in temperature

The maximum operating temperature is 104°F (40°C). Avoid abrupt variations in temperature. Any temperature variation should be made slowly.

### Protect from rough handling or dropping

Mechanical damage, external breakage, and/or internal breakage of the filter can result if the system is dropped or bumped. Handle with care at all times during transportation and installation.

### Protect from organic solvents and concentrated acids

Prevent any and all contact of the membrane with strong solvents, solvents containing chlorine, or concentrated acids. Do NOT use strong solvents or concentrated acids on any plastic parts of the filter system. Examples of some solvents to avoid: acetone, methyl acetate (nail polish remover); hexane (spot removers); turpentine, toluene (paint thinners); dry cleaning solutions, insecticides.

### Protect from abrasive material

The membranes must be protected from abrasive materials like shavings left in a pipe. Abrasive materials in contact with the membrane can cause irreversible damage to the membrane. All pipes must be flushed clean before installing the filter. All plastic parts of the filter system must be protected from sharp objects like knives, sand paper or other tools. Cutting or nicking a plastic part can weaken it and cause a leak. Do NOT use abrasive cleansers on any plastic parts.

### Protect from water hammer

The system must be protected from shock, pressure surges, or pulsation that may occur inside water pipes. Water hammer occurs in pipes when a valve or faucet shuts quickly. Install a water hammer arrestor (pressure vessel containing compressed air separated from the water by a diaphragm) to reduce pressure shock.



**This equipment is to be installed to comply with the basic plumbing code of the Building Officials and Code Administrators, Inc. (BOCA) and the Food Service Sanitation Manual of the Food and Drug Administration (FDA).**



**Water Flow Regulator Assemblies are NOT interchangeable. Operating the system with the wrong Water Flow Regulator or without a regulator can damage the system, cause personal injury, and void the warranty!**

## SPECIFICATIONS

### Dimensions

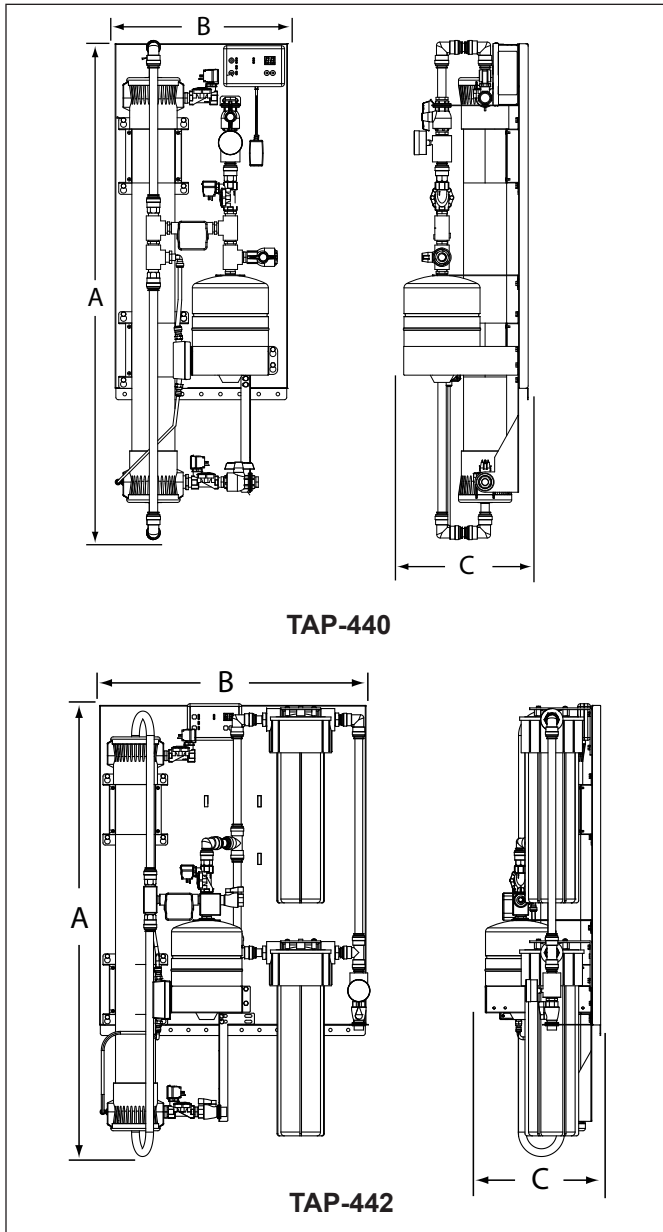



Model & Mfg. No.	Height (A)	Width (B)	Depth (C)
TAP-440 9700830 9700831	51-1/2" (131 cm)	18" (46 cm)	13" (33 cm)
TAP-441 9700840	51-1/2" (131 cm)	30" (76 cm)	13" (33 cm)
TAP-442 9700700 9700701 9700850 9700851	51-1/2" (131 cm)	30" (76 cm)	13" (33 cm)

### ⚠ CAUTION ⚠

All electrical connections must be in accordance with local electrical codes and any other applicable codes.

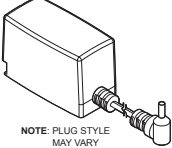
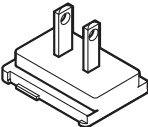
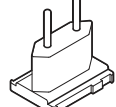
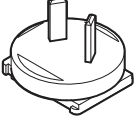
### Electrical Cord & Plug Configurations

Kit Model Number	Description	Configuration
0012146	DC Power Supply 100 - 240 VAC Includes the 4 plug adaptors below	
	US NEMA 1-15 (2 pin) or NEMA 5-15 (3 Pin)	
	Euro CEE 7/16	
	AS/NZS 3112 AUS (2 Pin)	
	UK BS 1363	

### Operating Weights

Model & Mfg. No.	Operating Weight
TAP-440 9700830 9700831	75 lbs. (34 kg)
TAP-441 9700840	105 lbs. (48 kg)
TAP-442 9700700 9700701 9700850 9700851	120 lbs. (54 kg)

### Replacement Cartridges

Replacement		Part Number
TAP-440 Family	Ultra Filtration L-440	7000412
TAP-441, 442	Single-Pack Carbon	7000669*

\*Note: Two kits required for full carbon replacement of TAP-442 system.

**SPECIFICATIONS (continued)**

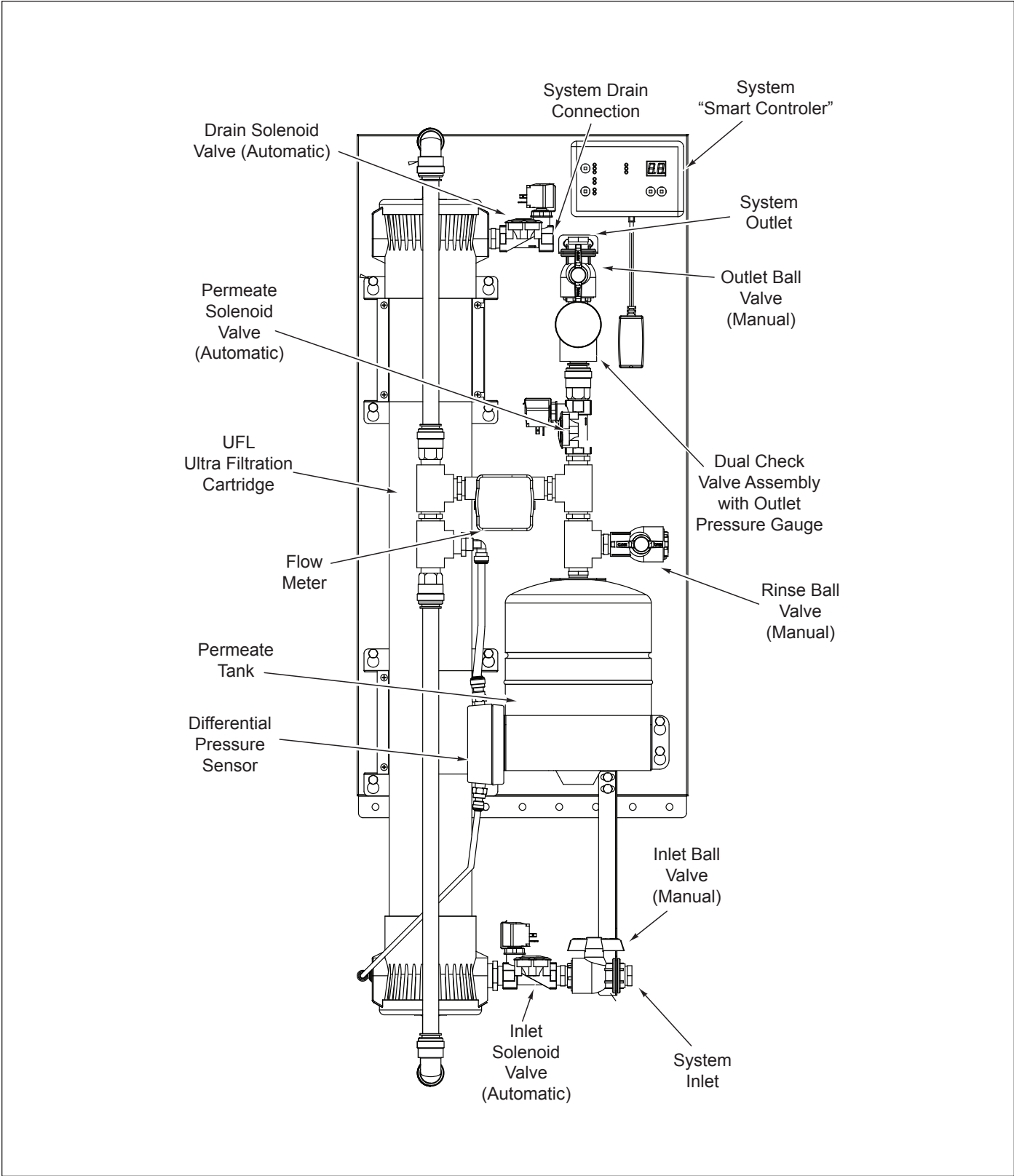

**Figure 1a. TAP-440 System Components**

**SPECIFICATIONS (continued)**

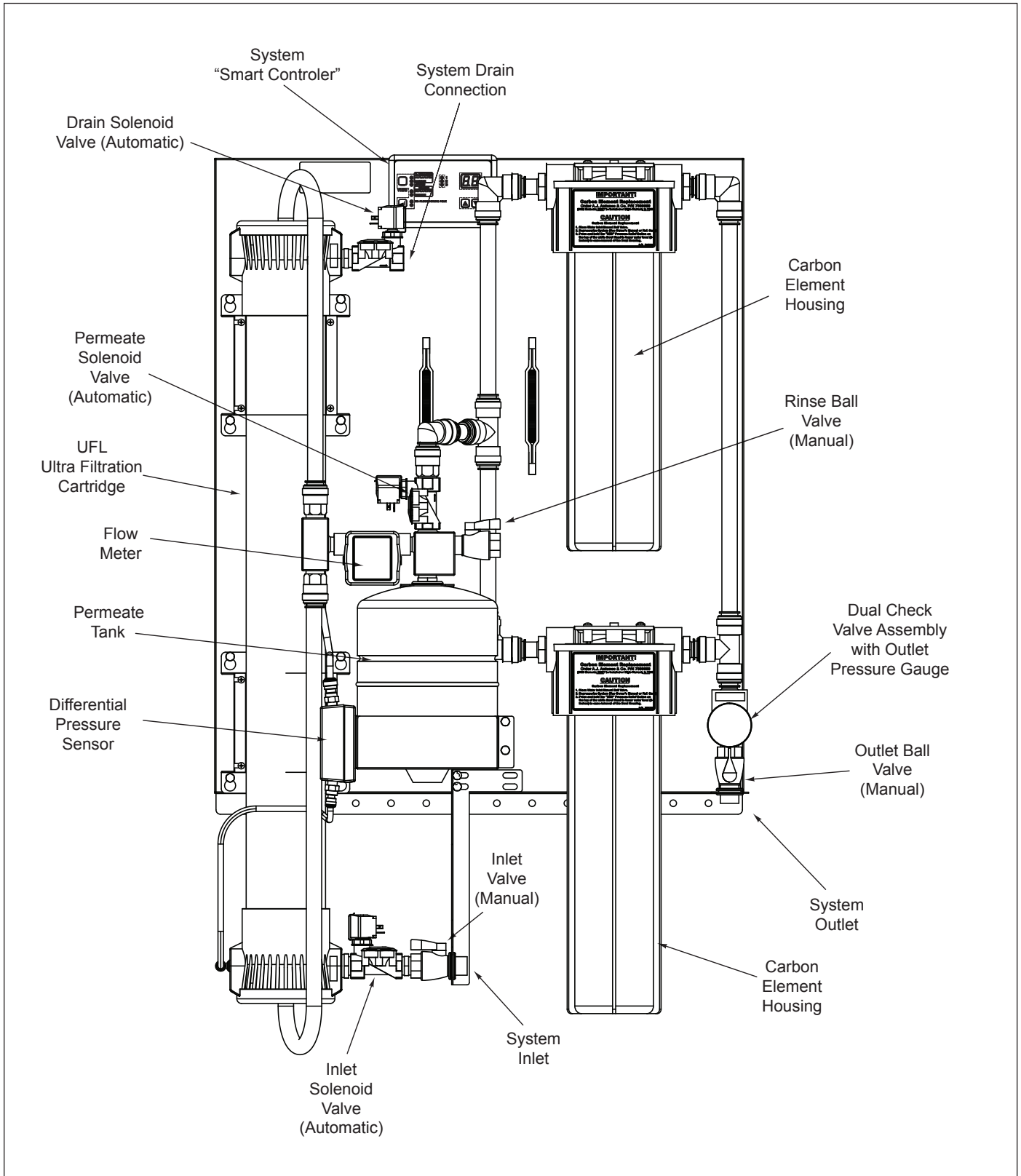

**Figure 1b. TAP-442 System Components**

**PERFORMANCE DATA SHEET**

**Filter Cartridge Capacities**

Maximum Operating Pressure	100 psig (690 kPa)
Maximum Operating Temp.	104°F (40°C)
Minimum Operating Temp.	40° F (4° C)
pH Range	3-10
MWCO	100 kD
Pore Size	.02 microns



Cartridge Tested and Certified by NSF International against NSF/ANSI for the reduction of:

Standard No. 42: Aesthetic Effects  
Nominal Particulate Reduction Class I  
Standard No. 53: Health Effects  
Cyst Reduction  
Turbidity Reduction

**System Capacities**

Model Mfg. No.	Gal./Liters Per Min. (max)	Carbon Element Capacity	UF Length	Number of Carbons
TAP-440 9700830 9700831	10 gal. (38 liters)	0	40 in. (102 cm)	0
TAP-441 9700840		60,000 gal. (227,000 liters)		1
TAP-442 9700700 9700701 9700850 9700851		120,000 gal. (454,000 liters)		2

Cartridge has been tested according to NSF/ANSI Standard 42 and 53 for reduction of the substances listed below. The concentration of the indicated substances in water entering the system was reduced to a concentration less than or equal to the permissible limit for water leaving the system, as specified in NSF/ANSI 42 or 53. While testing was performed under standard laboratory conditions, actual performance may vary.

**Performance Claims for Percent Reduction**

Substance	Influent Challenge Concentration	Reduction Requirement
cyst <sup>1</sup>	minimum 50,000/L	99.95%
Turbidity	11+/1 NTU	≤ 0.5 NTU
Particulate Class I Particles 0.5 to < 1µm	at least 10,000 particles /mL	85%

<sup>1</sup>based on the use of microspheres or *Cryptosporium parvum* oocysts

**NOTE: The NSF Information provided above applies to the TAP system's Ultra Filtration Cartridge.**

**WATER CONDITION EQUIPMENT GUIDELINES**

The following table describes the required or recommended equipment to be used with your filtration system based on the Inlet Water Pressure and Inlet Turbidity.

If your Inlet Turbidity (NTU) is...	Then the Additional Equipment required or recommended is...
Less than 1 NTU	<i>Required:</i> No additional equipment. <i>Recommended:</i> Inlet Water Strainer (180 micron/80 mesh screen)
Greater than 1 NTU	<i>Required:</i> Inlet Water Strainer (180 micron/80 mesh screen)

## INSTALLATION

### System Overview

The TAP System has two components that improve the quality of the water. The first (UFL-440 Ultra Filtration) removes particulate material and cysts. The second (carbon elements) remove chlorine, tastes and odors. The system is designed to be self-cleaning by use of solenoid valves, sensing components, and a Smart Controller.

### Unpacking (TAP-441/442)

1. Open the main box. It should contain:
  - A. Large System Box
2. Open the Large System Box. It should contain:
  - A. Plate-mounted TAP-441/442 System with TAP Smart Controller and Quick Reference Card
  - B. One or two Carbon Element(s) and Housing
  - C. One 20-foot coil of flexible hose
  - D. Accessory Box
  - E. Padded Envelope

**NOTE: To remove the system, cut the four corners of the box and then lift the system by the black handles on backplate (some systems). Do NOT lift the unit by the plumbing. Follow instructions attached to the outside of the box.**

3. Open the Accessory Box. It should contain:
  - A. Mounting bracket
  - B. Four bent Pex tubing
  - C. Inlet Support Bracket
4. Open the Padded Envelope. It should contain:
  - A. Outlet Check Valve Assembly
  - B. Carbon Bowl Wrench
  - C. Power Adaptor
  - D. Owner's Manual
5. Remove all packing materials and protective coverings from the system.
6. Assemble the system according to the instructions on the outside of the box.

### Unpacking (TAP-440)

1. Open the main box. It should contain:
  - A. Large System Box

**NOTE: To remove the system, cut the four corners of the box and then lift the system by the black handles on the backplate (some systems). Do NOT lift the unit by the plumbing. Follow instructions attached to the outside of the box.**

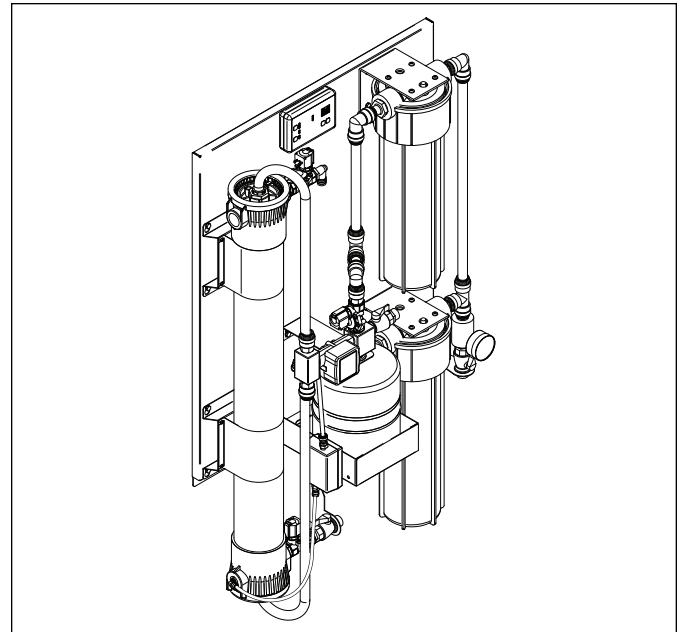

**Figure 2. TAP-442 System**

2. Open the Large System Box. It should contain:
  - A. Plate-mounted TAP-440 with TAP Smart Controller and Quick Reference Card
  - B. One 20-foot coil of flexible hose
  - C. Accessory Box
3. Open the Accessory Box. It should contain:
  - A. Mounting bracket
  - B. Two bent Pex tubing
  - C. Padded Envelope
4. Open the Padded Envelope. It should contain:
  - A. Outlet Check Valve Assembly
  - B. Power Adaptor
  - C. Owner's Manual
5. Remove all packing materials and protective coverings from the system.
6. Assemble the system according to the instructions on the outside of the box.
7. Remove the information packet. To prevent any delay in obtaining warranty coverage, fill out and mail the warranty card.

**NOTE: If any parts are damaged, contact A.J. Antunes & Co. IMMEDIATELY at 800-253-2991 (toll free in the U.S. and Canada) or 630-784-1000.**

## INSTALLATION (continued)

### Equipment Setup

#### GENERAL

When placing the system into service, pay attention to the following guidelines:

- Do NOT immerse cord or plug in water.
- Keep cord away from heated surfaces.

#### ELECTRICAL

Make sure the plug on the power cord matches the appropriate outlet. For proper operation, and to ensure the highest quality water, do NOT connect the system to a switched electrical outlet.

#### PLUMBING

**NOTE: The TAP system is designed to use tap water not to exceed 104°F (40°C).**

**NOTE: The system must be connected to the cold water line. Do NOT connect the system to the hot water line.**

The TAP system uses the following connections:

<b>System Inlet</b>	Male 3/4" NPT
<b>System Outlet (Product Water)</b>	Male 3/4" NPT
<b>Drain</b>	3/4" I.D. Hose Barb
<b>Rinse Outlet</b>	3/4" GHT (Garden Hose)

When making a plumbing connection to the system, use a backup wrench on the supporting plumbing. Always use a quality, approved pipe sealant or Teflon® tape on pipe threads. Be careful not to get the pipe sealant inside the pipe when making connections.

Do NOT over tighten the connections. Use plastic fittings when connecting to the plastic connections of the system.

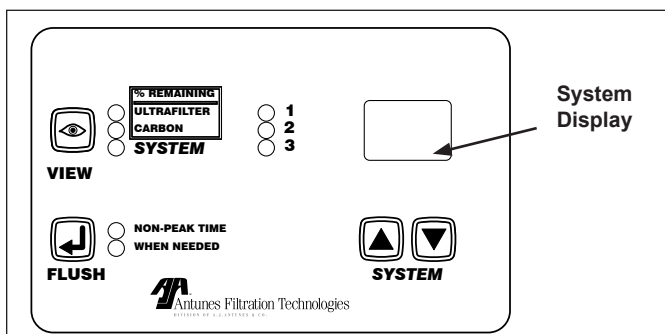

Figure 3. TAP System Control Panel

### ⚠ CAUTION ⚠

This equipment is to be installed to comply with the basic plumbing code of the Building Officials and Code Administrators, Inc. (BOCA) and the Food Service Sanitation Manual of the Food and Drug Administration (FDA).

### ⚠ CAUTION ⚠

**Water Flow Regulator Assemblies are NOT interchangeable. Operating the system with the wrong Water Flow Regulator or without a regulator can damage the system, cause personal injury, and voids the warranty!**

If soldered plumbing is used, do NOT apply heat to or near the filtration system. The use of union (O-ring seal) connections is highly recommended for ease of installation and future servicing.

#### SUGGESTED TOOLS AND SUPPLIES FOR INSTALLATION

The following tools and supplies are suggested to make the installation easier:

- Screwdriver
- Drill with Bits
- Tape Measure
- Two Gallon Bucket
- Pipe Wrenches
- Wall Anchors
- Bypass Kit
- Adjustable Wrenches
- Level
- Pipe dope or Teflon® tape
- Fresh 6% unscented liquid chlorine bleach (such as Clorox®)
- Garden Hose, 3/4"
- Molly Bolts

#### FLOW REGULATOR ASSEMBLY

The TAP system uses a Water Flow Regulator Assembly that controls the flow of water into the unit. This assembly consists of a white threaded male connector and a color-coded Flow Regulator. The unit **MUST** be operated with the appropriate Water Flow Regulator Assembly.

**TAP-440, 441, and 442 Units** use a Black and White Water Flow Regulator Assembly (10 gallons per minute).

**INSTALLATION (continued)**

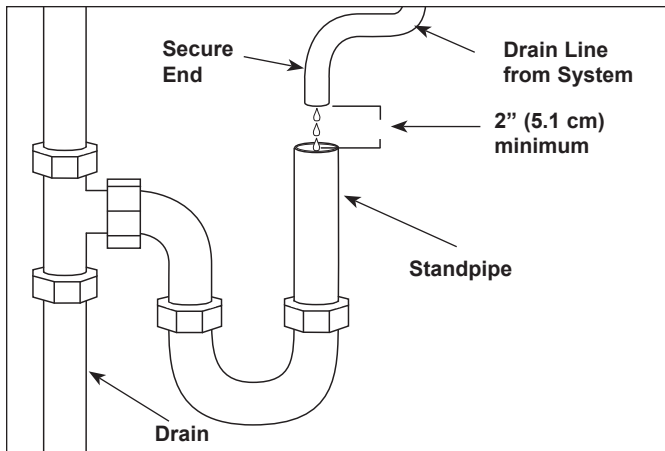

**Figure 4. Proper Drain Plumbing**

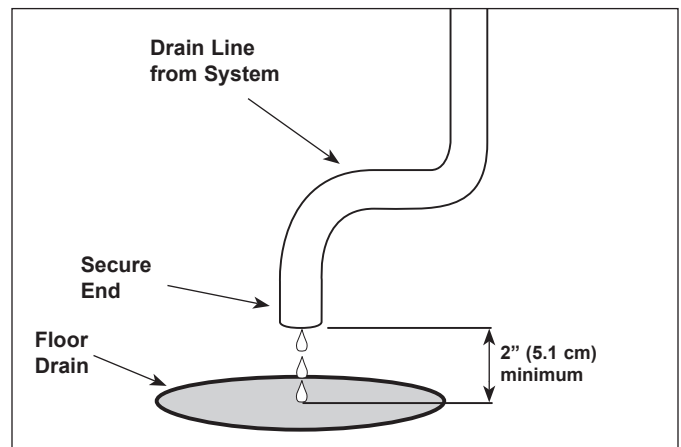

**Figure 5. Proper Drain Plumbing With Floor Drain**

**INLET WATER PLUMBING**

If desired, a “T” or Cross Fitting with cap or plug can be installed between the Inlet Ball Valve and the System Inlet. This fitting can be used for draining and sanitizing the system and downstream plumbing.

The plumbing leading to the system must be clear of all debris before connecting to the system inlet. Hold a bucket at the inlet water line and slowly open the Inlet Ball Valve. Allow the pipe to flush until all debris is removed.

**DRAIN LINE PLUMBING**

The drain line flushes particle buildup out of the system during self cleaning and must be able to support the flow rate when the system flushes. The flow rate from the flush depends on the inlet water pressure, inlet pipe size, and system selected. The drain opening should be as large or larger than the inlet plumbing line. The drain line leading out of the system should be as short as possible, sloping downward without kinks or loops. Be sure the drain used is not blocked or restricted.

Protect the system from possible back contamination by installing an air gap between the drain connection of the system and the drain (Figures 4 and 5). This gap in the line, with no physical contact between the system and drain, prevents contamination of the system in the event of a backed-up drain.

**NOTE: Make sure the end of the drain line is positioned and secured at least 2 inches above the drain so that the water flow is directed into the drain without splashing. Make sure the drain is capable of handling a flow of 10 gallons per minute.**

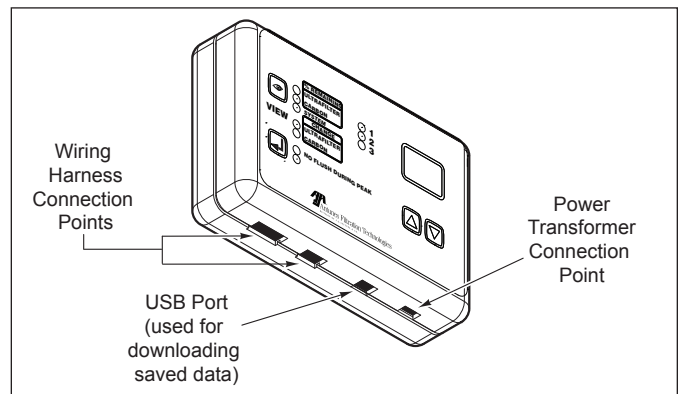

**Figure 6. Smart Controller Inputs**

**SMART CONTROLLER AND WIRING HARNESSES**

TAP Systems come with the Smart Controller attached. If the system is disassembled, follow these steps to reattach the Smart Controller:

1. Using the provided Velcro® fastener, connect the Smart Controller to the system (Figure 2).
2. Plug the two wiring harness connectors into the appropriate spots on the bottom of the Smart Controller (Figure 6).

**NOTE: Do NOT plug the power transformer into the Smart controller at this time. Mount the system to the wall first before attaching the power.**

**INSTALLING CARBON ELEMENT & HOUSING (TAP-441/442 UNITS ONLY)**

1. Screw the Carbon Element Housing into the Carbon Filter Head. Do NOT overtighten.

## INSTALLATION (continued)

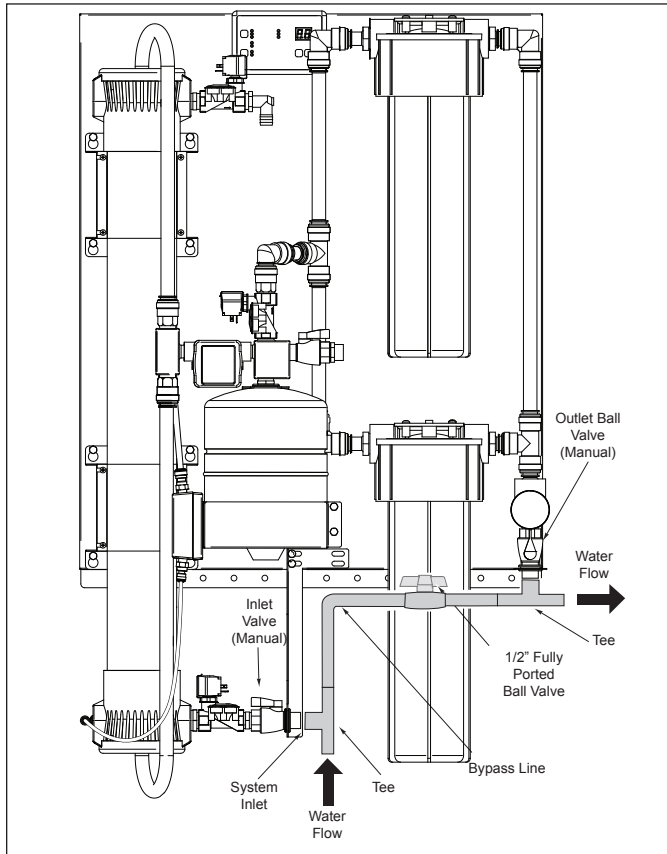

**Figure 7. Installing a Bypass**

### Installing a Bypass

It is recommended that a bypass is installed on the TAP System. This will make it easier to replace cartridges and service the system. Installation of a bypass can be done easily since the Inlet and Outlet Ball Valves are already installed. Follow these steps to install a bypass on your TAP System:

1. Install a tee on the Inlet and Outlet Ball Valves.
2. Connect one leg of the tee on the Inlet Ball Valve to the water inlet and the other leg to the tee on the Outlet Ball Valve.
3. Connect the two tees by creating a plumbing bypass line.
4. Install at least a fully ported 1/2" (preferably 3/4") Ball Valve on the bypass line connecting the two tees.
5. When the TAP System is in service, open the Inlet and Outlet Ball Valves and close the Bypass Ball Valve.
6. When servicing is needed, close the Inlet and Outlet Ball Valves and open the Bypass Ball Valve.

### Mounting the System

The TAP system comes with a Mounting Bracket (TAP-440 P/N 0505560; TAP-442 P/N 0505558) to assist in mounting the system securely. Consider these important points when choosing a mounting location:

- The system must be mounted with sufficient access for cartridge replacement. The system should be mounted as close to the ceiling as possible to allow proper access when changing cartridges.
- The system must be mounted near an appropriate electrical outlet.
- The system must be mounted near a drain for flushing operations.
- The system must be installed in front of all consumable water filtration processes.
- The system **MUST** be mounted with the provided Mounting Bracket and mounting hardware capable of supporting 120 lbs (54 kg) or more of weight.
- The Mounting Bracket must be secured into wall studs or with the appropriate heavy duty mounting hardware.

The TAP System is pre-assembled to a back plate. The back plate has mounting holes across the bottom portion to secure the bottom of the system to the wall. Some of the bottom mounting holes may be obscured by the UFL Cartridge. Plan your mounting accordingly.

**INSTALLATION (continued)**

**⚠ CAUTION ⚠**

Due to its weight and size, the TAP system should be mounted by two or more individuals. Use the handles to lift the system (some units). The system **MUST** be mounted with the provided Mounting Bracket. Read the **ENTIRE** section on *Mounting the System* **BEFORE** attempting to mount the TAP system.

**⚠ IMPORTANT ⚠**

Allow 40 inches above or below the Ultra Filtration Cartridge for ease of replacement.

Follow these steps to secure the Mounting Bracket to the wall and seat the TAP system on the bracket:

1. Use a level and a studfinder to attach the Mounting Bracket securely to the wall with the appropriate mounting hardware (Figure 8).
2. The Mounting Bracket is designed so that the TAP system can be lifted and hung on the Mounting Bracket. With assistance from another person, lift the TAP system and seat it onto the Mounting Bracket securely (Figure 8).
3. Secure the bottom portion of the TAP system to the wall using the holes provided. Make sure to secure the system into wall studs or use the appropriate mounting hardware (Figure 9).

**NOTE: If the surface of the wall is rough or uneven, mount a 2 x 4 to the wall and attach the bracket to it. The 2 x 4 should be 30" wide.**

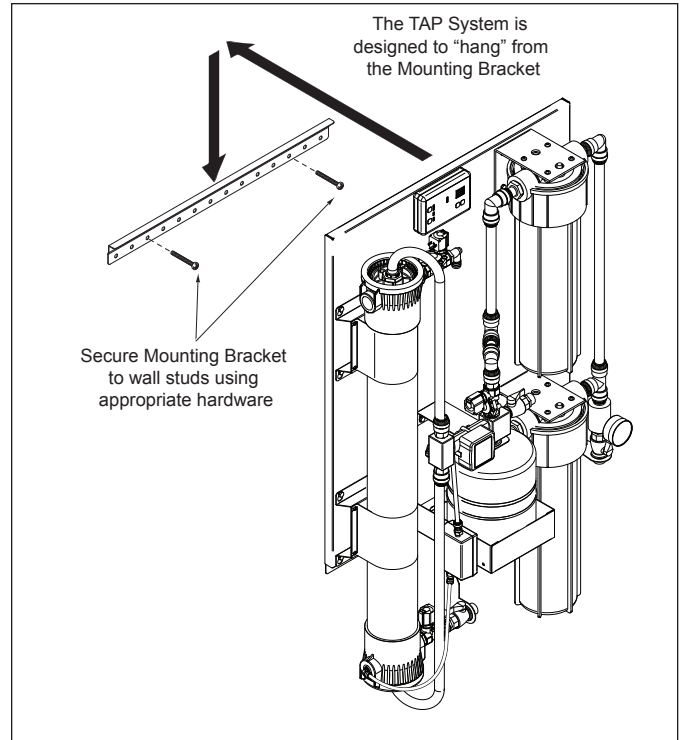

**Figure 8. Mounting the TAP System**

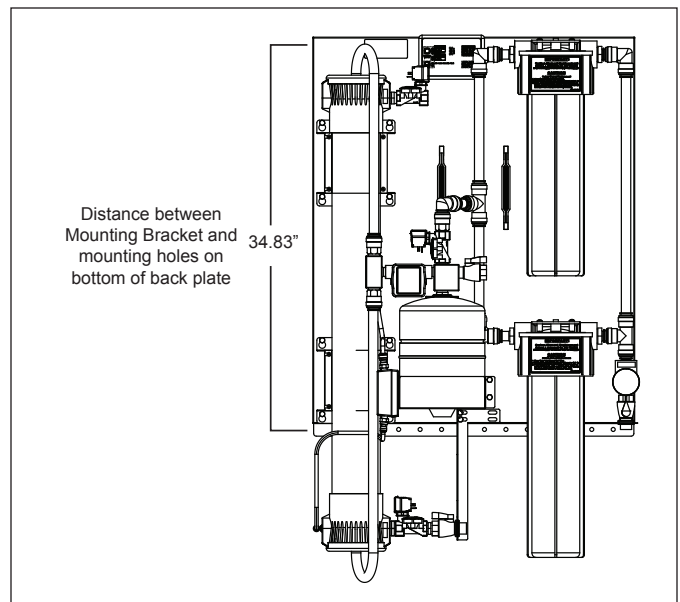

**Figure 9. Mounting Dimensions of TAP System**

## INSTALLATION (continued)

### Check Valve Assembly

The Dual Check Valve assembly can be detached from the system for ease of mounting, but it must be reattached to the system after mounting. Refer to Figure 10 and follow these steps:

1. Insert the Dual Check Valve assembly into the System Outlet.
2. Make sure the Dual Check Valve assembly is fully inserted into the System Outlet fitting.

**NOTE: Do NOT remove the pipe nipple and the connected System Outlet Ball Valve from the Dual Check Valve assembly.**

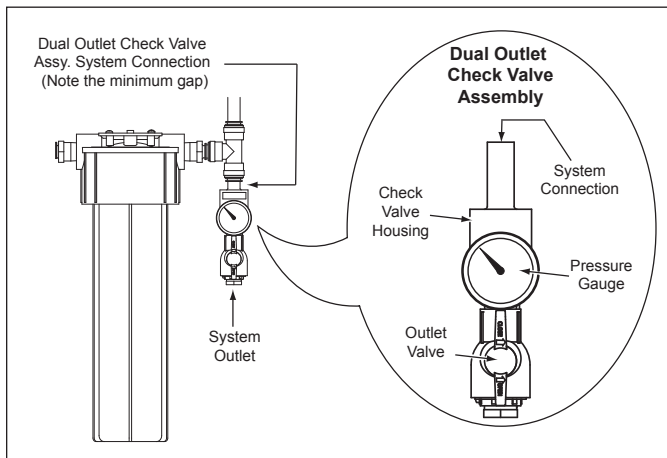

Figure 10. Dual Check Valve Assembly

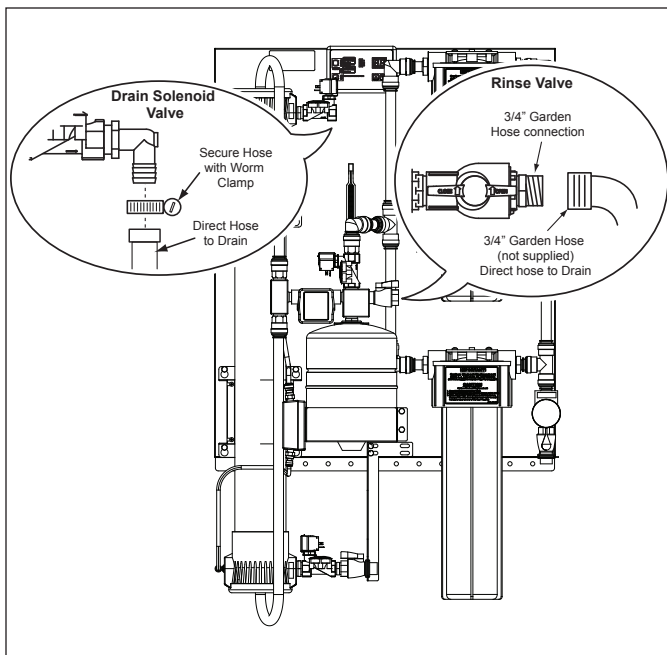

Figure 11. Attaching the Drain Hose (TAP-442)

### Drain Hose Connection

The TAP System is shipped with a 20-foot coil of braided tubing designed to direct the Drain Valve Solenoid water to the drain. Refer to Figure 11 below and follow these steps:

1. If necessary, cut a length of braided tubing so that it reaches the drain from the appropriate valve.
2. Connect one end of the hose to the Drain Valve Solenoid and secure with a provided Worm Clamp.
3. Direct the other end of the hose to the drain.

**NOTE: The drain MUST be able to accommodate a drain flow of 10 gpm. The drain hose MUST have an air gap between the end of the hose and the drain.**

### Rinse Hose Connection

The TAP System has a standard 3/4" garden hose connection at the Rinse Ball Valve.

1. Obtain a length of 3/4" garden hose long enough to reach from the Rinse Ball Valve connection to the drain.
2. Install a gasket in the end of the hose (non-drain end).
3. Connect the hose to the Rinse Ball Valve fitting. Use a back-up wrench on the fitting if required.
4. Direct the other end of the hose to the drain. Secure as necessary.

**NOTE: The drain MUST be able to accommodate a flow of 10 gpm.**

### CAUTION

**Do NOT use the Rinse Valve connection for consumable water. Because the Carbon Elements are after the Rinse Valve, the Rinse Valve water may have an objectionable taste.**

**INSTALLATION (continued)**

**Attaching to the System Inlet**

The System Inlet (Figure 12) has a 3/4" NPT male thread at the Inlet Ball Valve. **Be careful not to over tighten a fitting onto the System Inlet Ball Valve. The plastic ball valve can be cracked due to over tightening a fitting into the valve.** Use a plastic fitting to connect to the System Inlet. Use an approved pipe thread sealant that is approved for use on PVC fittings.

**Attaching to the Filtered Water Permeate Outlet**

The system outlet (Figure 13) has a 3/4" NPT male thread at the Outlet Ball Valve. **Be careful not to over tighten a fitting onto the Outlet Ball Valve. The plastic ball valve can be cracked due to over tightening a fitting into the valve.**

It is recommended that a plastic fitting be used in the outlet. Use a drinking water-approved pipe thread sealant that is approved for use on PVC fittings.

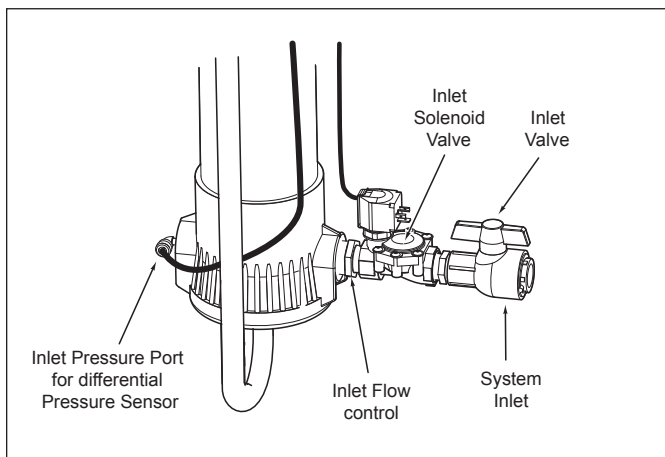

**Figure 12. TAP System Inlet Assembly**

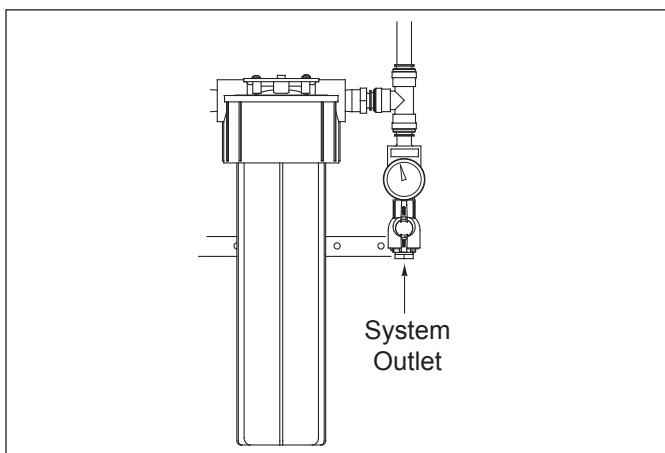

**Figure 13. TAP System Outlet**

**Starting the System**

**NOTE: Be sure that ALL ball valves are closed before starting the system.**

Follow these steps to power up the system:

1. After the system is mounted, connect the power supply to the bottom right of the Smart Controller (Figure 6).
2. Select the appropriate adaptor for your power outlet and attach the adapter to the transformer.
3. Plug the transformer into the appropriate outlet that has power to it at all times.

**NOTE: Do NOT plug the power transformer into an outlet that will be switched off. Failure to supply power to the system at all times may result in short cartridge life or bad tasting water.**

**NOTE: The system is designed to supply water even with the power off. However, with power off, the system will not flush or monitor any usage.**

**SETTING THE INTERNAL CLOCK**

The Display flashes "CL", indicating that the Internal Clock **must be set before any other action can take place**. The unit beeps as a reminder to set this value. To set the clock:

1. Press and hold (in order) the **VIEW** and **▲** buttons until the red System LED illuminates and "--" appears on the display.
2. Release all buttons.
3. Use the **▲** and **▼** buttons to scroll to **01**.
4. Press the **FLUSH** button.
5. Use the **▲** and **▼** buttons to set the local date and time and press the **FLUSH** button after each selection to save the data. The clock should be set to local time in the following format:

YY; MM; DD; HH (0-23); MM

**NOTE: The system uses a 24 hour clock. If the local time is 3:45 PM on July 2, 2008, the clock would be set as 08; 07; 02; 15; 45.**

## INSTALLATION (continued)

### Rinsing the Ultra Filtration Cartridge

The Ultra Filtration Cartridge is pre-installed with the TAP System before shipment. This cartridge **must** be rinsed before placing the system into operation to remove air and the shipping solution from the Ultra Filtration Cartridge.

Follow these steps to rinse the Ultra Filtration Cartridge. This will take approximately 40 minutes.

1. **Manually** close the Inlet Ball Valve (Figure 1a and 1b).
2. Make sure a drain hose is connected to the Rinse Ball Valve. Direct this hose to a drain.

**⚠ CAUTION ⚠**

**Ingesting the protective solution may cause irritation of the gastrointestinal tract, colic, diarrhea, or other similar symptoms.**

3. **Manually** open the Rinse Ball Valve (Figure 1a and 1b).
4. Enter the **06** program. Press and hold (in order) the **VIEW**, and **▲** buttons until the red **SYSTEM** LED illuminates and “ -- ” appears on the display (Figure 14).
5. Use the **▲** button to scroll up to “**06**” and press the **FLUSH** button to start the rinse program. The system displays **d1** and begins to depressurize. Wait until the system beeps and flashes **d3**.
6. **Manually** open the Inlet Ball Valve. Press the **FLUSH** button to start the **r1** stage.
7. Wait until the display flashes **r1** (approximately 1 minute) and the system beeps.
8. Press the **FLUSH** button. The system starts the **r2** stage.
9. Wait until the display flashes **r2** (approximately 15 minutes) and the system beeps.
10. **Manually** close the Rinse Ball Valve.
11. Press the **FLUSH** button to start the **r3** stage.
12. Wait until the display flashes **r3** (approximately 15 minutes) and the system beeps.

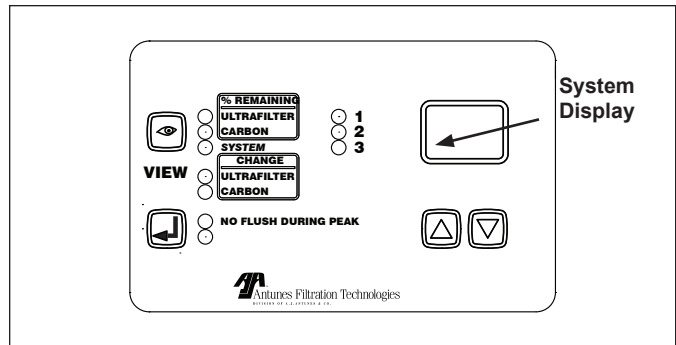

**Figure 14. TAP System Control Panel**

13. **Manually** open the Rinse Ball Valve.
14. Press the **FLUSH** button to start the **r4** stage (Rinse Flow stage).
15. Wait until the display flashes **r4** (approximately 5 minutes) and the system beeps.
16. **Manually** close the Rinse Ball Valve.
17. Press the **FLUSH** button to start the **r5** stage.
18. Wait for 1 minute. Water flows through the UFL housing and out of the Drain Solenoid Valve.
19. The system begins the **r6** stage. The system completes depressurization and displays **d3**.
20. Repressurize the system using the **08** program. Press and hold the **VIEW** and **▲** buttons until the red **SYSTEM** LED illuminates and “ -- ” appears on the display.
21. Use the **▲** button to scroll up to “**08**”.
22. Press the **FLUSH** button to start the Pressurize System program.

The system repressurizes and makes water available through the system.

**INSTALLATION (continued)****Sanitizing the System and Lines**

**NOTE: If installed, remove the Carbon Element(s) from the system BEFORE sanitizing.**

The plumbing must be sanitized to eliminate possible contamination that may have occurred during the installation process.

One ounce (30 ml) of liquid chlorine bleach (regular bleach, unscented 6 % sodium hypochlorite) can be used to sanitize the plumbing. The amount of bleach to use depends on the system installed and the amount of plumbing downstream of the TAP System.

**NOTE: Follow the handling and safety instructions supplied with the bleach.**

1. Press and hold (in order) the **VIEW** and **▲** buttons until the red **SYSTEM** LED illuminates and “ -- ” appears on the display.
2. Use the **▲** button to scroll up to “07” and press the **FLUSH** button to start the Depressurize System program.
3. Turn off the water to the system.
4. Remove the Carbon Element(s) if they are installed and reattach the Carbon Bowls.
5. Open the faucet closest downstream to the system.
6. Allow the system and plumbing to drain.
7. If an inlet sanitation fitting is installed, remove the plug or disconnect the water line at the inlet of the system. Allow the water to drain out of the system.
8. Pour the bleach into the inlet sanitation fitting or inlet water line using a cup or funnel. Be careful not to spill bleach onto clothing or skin.
9. Reattach the plug on the sanitation fitting or inlet water line.
10. Slowly turn on the water supply to the system.
11. Allow water to flow through the system and out of the open faucet until the smell of bleach is present.
12. Close the faucet and let the system stand without water flow for at least 15 minutes to allow the bleach to sanitize the pipes.
13. After 15 minutes without water flow, open the faucet.
14. Allow water to flow through the system until the presence of bleach is gone.
15. Open all other faucets in line with the system to flush any bleach from the plumbing.
16. Close all open faucets.
17. Replace the removed Carbon Element(s) by following the steps in the **Replacing the Carbon Element** in the Maintenance section of this manual.
18. If necessary, reinstall the Carbon Element(s) or install a new Carbon Element(s).
19. Repressurize the system using the **08** program. Press and hold the **VIEW** and **▲** buttons until the red **SYSTEM** LED illuminates and “ -- ” appears on the display.
20. Use the **▲** button to scroll to “08” and press the **FLUSH** button to start the Pressurize System program.

The system repressurizes and makes water available through the system. Sanitation is complete.

**Rinsing the Carbon Elements and Plumbing**

Once the system and lines have been sanitized, the Carbon Element(s) should be installed. Remove all plastic wrapping before inserting the Carbon Element(s) into the Carbon Bowl.

Before placing the system into operation, the Carbon Element(s) should be rinsed using the procedure below.

**NOTE: To ensure that the highest quality water is produced from the system, the Carbon Element(s) and plumbing leading from the filter system must be flushed clear of carbon fines and other debris.**

1. Direct water from the System Outlet to a drain.
2. Turn on the water to the system.
3. Allow water to flow through the Carbon Element(s) and Carbon Element Housing(s) to flush out trapped air and any debris that may be present.
4. To help remove trapped air from the Carbon Element Housing(s), press the red button on top of the housing until water just begins to come out.
5. Flush the Carbon Element(s) for at least 5 minutes.

**Note: Do NOT consume water used during this process.**

6. When the Carbon Element(s) flushing is complete, turn off the water to the system.
7. Reconnect the water to service. The system is now ready for use.
8. **For new piping installations:** After making the connection to the System Outlet:
  - a. Open the faucet or tap closest to the filter system.
  - b. Slowly open the Inlet Ball Valve.
  - c. Allow the pipe to flush until all debris is cleared.

## OPERATION

### Operation

The TAP System operates with little to no user intervention. The system monitors and flushes itself automatically.

### Manual Flushing

The TAP System is designed to automatically flush but can also be manually flushed when desired. To manually flush the system:

1. Press and hold the **FLUSH** button for 3 to 4 seconds.
2. The system enters the **FLUSH** program and automatically performs the following stages while displaying the stage code on the display throughout the process:
  - **F1** (Close Permeate Solenoid Valve stage)
  - **F2** (Close Inlet Solenoid Valve stage)
  - **F3** (Open Drain Solenoid Valve stage)
  - **F4** (Open Inlet Solenoid Valve stage)
  - **F5** (Close Drain Solenoid Valve stage)
  - **F6** (Open Permeate Solenoid Valve stage)

**NOTE: The system automatically performs these stages.**

3. Flushing is complete once the system completes the **F6** stage of the **FLUSH** program.

### System Power Loss

The TAP System is designed to run with constant power. Thus, the power cord should always be plugged into an appropriate power outlet that will not be switched off.

In the event of a power loss, the TAP System:

1. Aborts any active valve program.
2. Resets the valves to normal operation (pressurized/water available).
3. Sounds an alert to notify the operator of the power loss.
4. Records the time of the power loss into the controller memory.
5. Displays the **EV-20** event code (indicating a loss of power).
6. The system beeps 4 times every 10 seconds for approximately 2 minutes. Then it beeps once every 30 seconds.

To turn off the audio alert, press and release both the **▲** and **▼** buttons at the same time.

**NOTE: Be sure to restore power to the system. The system displays the EV-21 code when power is restored to the system.**

### ⚠ CAUTION ⚠

The system continues to filter water even after a power loss but it will **NOT** flush. Therefore, running the system without power may shorten the life of the filtration elements. Make sure the system always has power.

### Viewing Filtration Element Data

The TAP System monitors the lifespan of the filtration elements and can display the percent-of-life remaining for the selected component. Follow these steps to view the Filtration Element Data:

1. Press the **VIEW** button to cycle through the Ultra Filtration and Carbon LEDs.
2. Pressing the **VIEW** button again steps to the next component.
3. The system displays the percent-of-life remaining for the selected component in the display.

### Viewing Sensor Readings

The TAP System uses the Flow Meter and Differential Pressure Sensor to monitor the Flow Rate and Differential Water Pressure respectively.

The system also uses measurements to determine when to automatically flush and it monitors the effectiveness of the flush operations. To view this data:

1. Press and hold both the **VIEW** and **▼** buttons until the Red **SYSTEM** LED illuminates.
2. Press the **VIEW** button to scroll through the green LEDs (Figure 15) that indicate the following data:
  - **LED 1** (top): Used to determine when the system automatically flushes and measures the effectiveness of flush operations.
  - **LED 2** (middle): Flow Rate, in gallons per minute (gpm)
  - **LED 3** (bottom): Differential Water Pressure, in pounds per square inch (psi)
3. To exit, press and hold the **FLUSH** button until the red **SYSTEM** LED turns off.

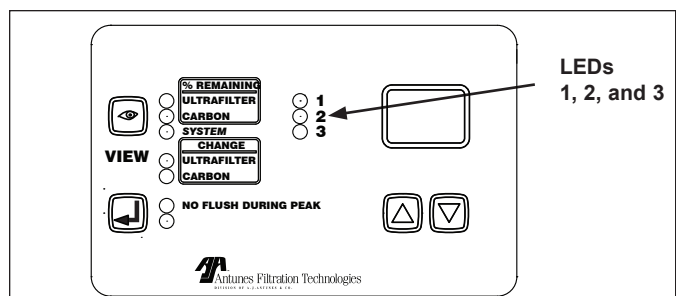

Figure 15. TAP System Control Panel

## MAINTENANCE

### Operation

The TAP system is designed to operate with little to no user intervention. The system monitors and flushes itself automatically.

### Manual Flushing

The TAP system is designed to automatically flush but can also be manually flushed when desired. To manually flush the system:

1. Press and hold the **FLUSH** button for 3 to 4 seconds.
2. The system enters the **FLUSH** program and automatically performs the following stages while displaying the stage name on the display throughout the Flush process:

- **F1** (Close Permeate Solenoid Valve stage)
- **F2** (Close Inlet Solenoid Valve stage)
- **F3** (Open Drain Solenoid Valve stage)
- **F4** (Open Inlet Solenoid Valve stage)
- **F5** (Close Drain Solenoid Valve stage)
- **F6** (Open Permeate Solenoid Valve stage)

**NOTE:** The system automatically performs these stages

3. Flushing is complete once the system completes the **F6** stage of the **FLUSH** program.

### System Power Loss

The TAP system is designed to run with constant power. Thus, the power cord should always be plugged into an appropriate power outlet that will not be switched off.

In the event of a power loss, the TAP System:

1. Aborts any active valve program.
2. Resets the valves to normal operation (pressurized/water available).
3. Sounds an alert to notify the operator of the power loss.
4. Records the time of the power loss into the controller memory.
5. Displays the **EV-20** event code (indicating a loss of power).

The system beeps 4 times every 10 seconds for approximately 2 minutes. Then it beeps once every 30 seconds.

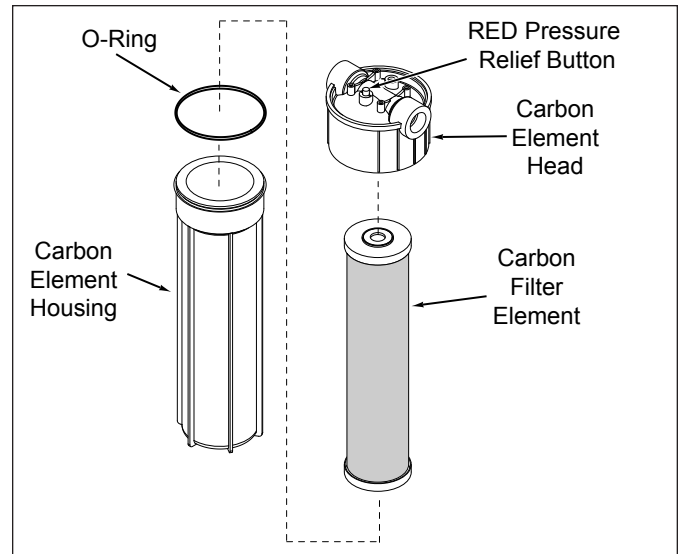

**Figure 16. Replacing the TAP Carbon Element**

To turn off the audio alert, press and release both the **▲** and **▼** buttons at the same time.

**NOTE:** Be sure to restore power to the system. The system displays the **EV-21** code when power is restored.

### Replacing the Carbon Element

The life of a Carbon Element depends on the overall quality of the water in the area. Follow these steps to replace the Carbon Element:

1. Turn off water to the system by closing the Inlet Ball Valve and the Outlet Ball Valve.
2. Run the **03** program. Press and hold the **VIEW** and **▲** buttons until the red system LED illuminates and “ -- ” appears on the display.
3. Use the **▲** and **▼** buttons to scroll to **03**.
4. Press the **FLUSH** button.

The system performs the **03** program, which consists of the following stages:

- **C1** (Close Inlet Ball Valve stage)
- **C2** (Open Drain Valve stage)
- **C3** (Open Permeate Valve stage)

5. When the **03** program completes, press and hold the RED Pressure Relief Button on the top of the Carbon Element Housing (Figure 16) to lower the

## MAINTENANCE (continued)

### Resetting the Carbon Element Accumulated Total Value

The TAP system uses the Carbon Element Accumulated Total feature to measure the lifespan of the Carbon Element(s).

After installing the Carbon Element(s), the Carbon Element Accumulated Total value must be reset. This ensures that system maximizes the life of the Carbon Element(s).

1. Reset the Carbon Element Accumulated Total using the “**04 (Reset Carbon Element Accumulated Total)**” program. Simultaneously press the **VIEW** and **▲** buttons until the red **SYSTEM** LED illuminates and “--” appears on the display.
2. Use the **▲** or **▼** buttons to scroll to “**04**” and press the **FLUSH** button to start the program. The system automatically resets the Carbon Element Accumulated Total. The display returns to “--”.
3. Press the **FLUSH** button again to return the system to normal operation.

### Replacing the Ultra Filtration Cartridge

**Note:** It is strongly recommended that new Carbon Elements be installed after a UFL cartridge is changed.

**NOTE:** Make sure there is enough room below the system to remove the cartridge.

1. Depressurize the system using the “**07 (Depressurize UFL System)**” program. Simultaneously press the **VIEW** and **▲** buttons until the red system LED illuminates and the system displays “--”. Use the **▲** and **▼** buttons to scroll to **07** and press the **FLUSH** button.

The system performs the **07** program, which consists of the following stages:

- **d1** (Close Inlet Ball Valve stage)
  - **d2** (Open Drain Valve stage)
  - **d3** (Close Permeate Valve stage)
2. When the **07** program completes, place a bucket under the Ultra Filtration Cartridge Housing. Locate the TAP Pressure Differential housing (Item #2 in the Replacement PArts list). Remove the 1/4” bottom tubing from the quick connect fitting located on the bottom of the pressure sensor

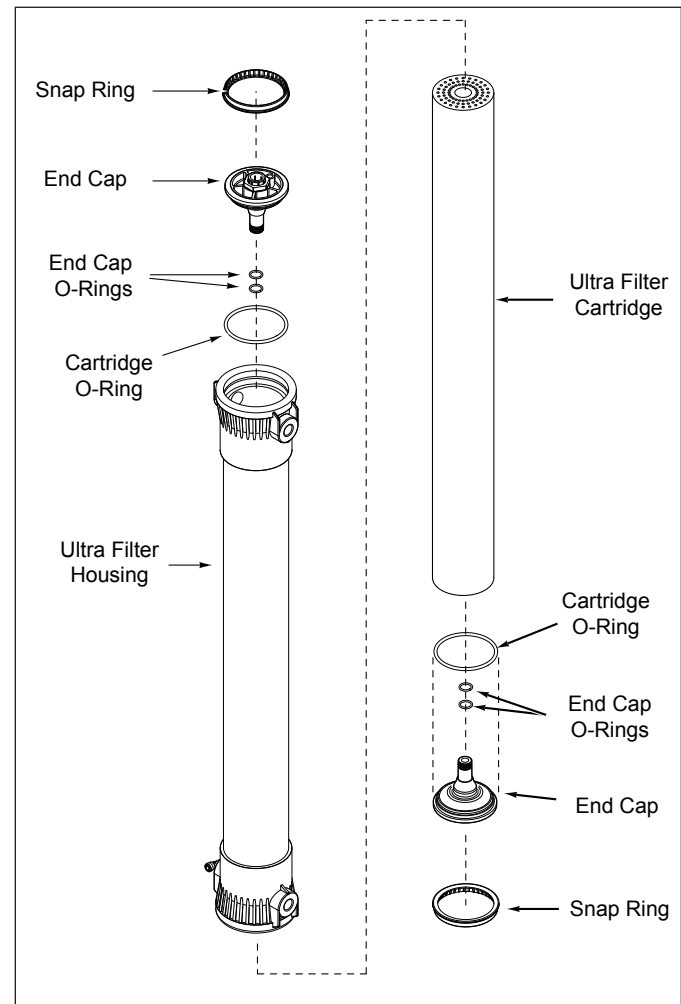

**Figure 17. Replacing the Ultra Filtration Element**

box and drain into the bucket. When the water is completely drained, disconnect the large bent bottom tubing from the quick connect fitting by the TAP water meter. Leave the tubing attached to the bottom end cap so it can be used to pull the end cap from the housing.

3. Remove the Snap Ring on the bottom end of the Ultra Filtration Housing. Grab the raised lug with a pair of pliers and pull towards the center of the end cap and away. The ring should lift out of its groove.
4. The lower End Cap, End Cap O-ring, and Cartridge should easily drop down out of the housing (Figure 17). If not, pull gently on the end cap to remove the cartridge.

**MAINTENANCE (continued)**

5. Inspect the cartridge O-rings and end cap O-ring for nicks or cuts. Replace as needed.
6. Lubricate all O-rings with a food-grade silicone lubricant (Figure 18). Apply a light coating of lubricant to the inside center tube at both ends of the new cartridge.

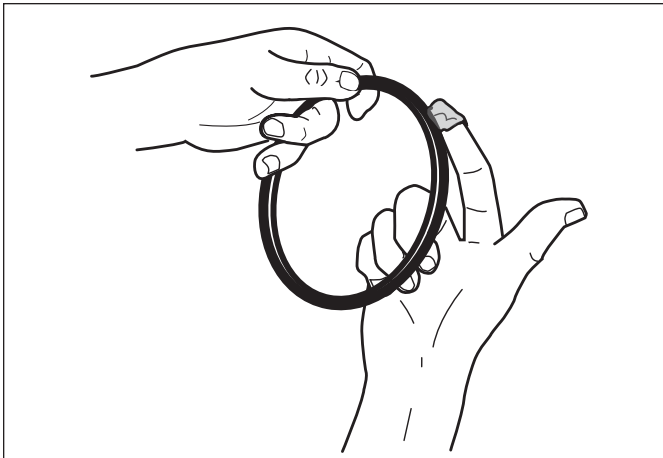

**Figure 18. Lubricating O-rings**

13. When rinsing is complete, the system must then be repressurized. Use the ▲ or ▼ buttons to scroll to “08” and press the **FLUSH** button to start the Pressurize program. The system will repressurize and make water available through the system.

**System Sanitization**

Over time and use, the plumbing downstream from the system may require sanitization. The system and downstream plumbing should be sanitized at least once a year. When necessary, follow the **Sanitizing the System and Lines** procedure in the Installation section of this manual.

7. Record the serial number of the new cartridge. The cartridge serial number is engraved on one end of the outer tube (for example: 05K 12013).
8. Install the End Cap O-ring on the End Cap and insert the End Cap into the end of the new cartridge.
9. Position the new cartridge and End Cap below the housing and gently insert into the housing.
10. Press the End Cap into position until it is fully seated and the Snap Ring groove is visible.
11. Install the Snap Ring by guiding the non-lugged end into the groove first, pushing outward, and working around the ring until it snaps into place.

**NOTE: Make sure that the Snap Ring is fully seated before turning the water on.**

12. The new filtration cartridge must be rinsed before operation. Follow the **Rinsing the Ultra Filtration Cartridge** and **Sanitizing the System and Lines** procedures in the Installation section of this manual to complete the cartridge change.

## MAINTENANCE (continued)

### Accessing TAP Controller Features

#### POWER LOSS TO SYSTEM (SYSTEM UNPLUGGED OR SUPPLY INTERRUPTED)

- Any active valve program is aborted
- Valves set so water is available
- Control “BEEPS” five times every 3 minutes if water flow is present
- If no flow present for 10 minutes, beeping stops until water flow starts again
- Pressing both ▲ and ▼ will silence beeper

#### FLUSH (BUTTON) AUTOMATIC OPERATION

Press and hold to run a Flush cycle. The system automatically performs the following stages in less than a minute:

- **F1** - Close Permeate Valve
- **F2** - Close Inlet Valve
- **F3** - Open Drain Valve
- **F4** - Open Inlet Valve
- **F5** - Close Drain Valve
- **F6** - Open Permeate Valve

#### VIEW (BUTTON) – NORMAL OPERATING MODE

Toggles between Ultra Filtration Cartridge % of life remaining and Carbon Elements % of life remaining

#### VIEW (BUTTON) – SENSOR READINGS

1. Press and hold (in order): **VIEW** button and ▼ button.
2. The red System LED illuminates.
3. Repeatedly push the **VIEW** button to scroll through the green LED’s, which indicate the following information:
  - LED #1** (Top) Based on the VER value, displays a numerical measure of how clean/dirty the Ultra Filtration Cartridge is. The higher the number, the more dirty the Cartridge is.
  - LED #2** (Middle) Flow Rate (gpm)
  - LED #3** (Bottom) Differential Pressure (psid)
4. To exit Sensor Readings, press the **FLUSH** button until red LED turns off.

#### ERROR CODE DESCRIPTIONS

EC-01 – Differential Pressure = 0 psid Flow Rate is greater than 0 gpm	EC-08 – Insufficient flush (Tank refill amount is less than ½ of the discharge amount)
EC-02 – Differential Pressure is greater than 45 psid (at any flow rate)	EC-09 – Memory data re-initialized
EC-03 – Differential Pressure is greater than 0 psid, Flow Rate = 0 gpm	EC-10 – Flow switch #1 fail
EC-06 – Flush Flow is less than 0.75 gallon	EC-11 – Flow switch #2 fail
EC-07 – Flow is greater than 10 gpm	EC-12 – Flow switches erratic
	EC-13 – EEPROM bad

#### EVENT CODE DESCRIPTIONS

- EV-20** – Power removed
- EV-21** – Power restored
- EV-22** – Carbon Element(s) changed
- EV-23** – UFL Filter changed
- EV-24** – Time exceeded, Flow Rate > 0

**MAINTENANCE (continued)**
**Service Menu Access**

To manually execute a program, press and hold, in order, the **VIEW** button and the **▲** button.

1. The red System LED illuminates and the "--" appears in the display. Release all buttons.
2. Use the **▲** and **▼** buttons to select the desired function and press the **FLUSH** button to execute the program.
3. To exit the Service Menu, press the **FLUSH** button until the red LED turns off.

"--" - Exit Service Level 2	<b>10</b> - Dump User Data out USB (serial) port
<b>01</b> - Set Clock (YY MM DD HH (0-23) MM) System uses a 24 hour clock. If the time is 3:45 PM on July 2, 2008, set clock to <b>08 07 02 15 45</b> . <b>Press FLUSH after each 2 digit entry.</b>	<b>11</b> - Dump Events out USB (serial) port
<b>02</b> - Set Flush Time (Hour 0-23; minute) <b>Press FLUSH after each 2 digit entry.</b>	<b>13</b> - Set Differential Pressure Sensor to 0 psi
<b>03</b> - Change Carbon Element	<b>14</b> - Display Error Codes. Use the <b>▲</b> and <b>▼</b> to view codes.
<b>04</b> - Reset Carbon Element Accumulated Total	<b>15</b> - Clear Displayed Error Codes (Data stays in memory)
<b>05</b> - Set Maximum Gallons for Carbon Element (x 10,000)	<b>24</b> - Reset to Factory Values
<b>06</b> - Rinse New UFL Membrane and reset UFL Total	<b>25</b> - Set Product Type (Model 42x = 2, Model 44x = 4). Use the <b>▲</b> and <b>▼</b> buttons.
<b>07</b> - Depressurize UFL System	<b>26</b> - Set for No Flush During Peak (11am-2pm). 1 = <b>ON</b> , 0 = <b>OFF</b> . Use the <b>▲</b> and <b>▼</b> buttons.
<b>08</b> - Pressurize System	<b>28</b> - Turns the display of Error Codes On or OFF 1 = <b>ON</b> , 0 = <b>OFF</b> . Use the <b>▲</b> and <b>▼</b> buttons.
<b>09</b> - Toggle Valves (open or closed). <b>INLET:</b> Use VIEW button, LED 1 lit when closed <b>PERMEATE:</b> Use <b>▲</b> , LED 2 lit when closed <b>DRAIN:</b> Use <b>▼</b> , LED 3 lit when closed The red System LED blinks in this mode.	<b>NOTE: Menu items 20, 21, 22, 23, and 27 are for factory use ONLY.</b>

**PROGRAM DESCRIPTIONS** (Simultaneously pressing the **▲** and **▼** buttons aborts any active program).

**03 - (Change Carbon Element)**

- **C1** - Close Inlet Valve stage
- **C2** - Open Drain Valve stage
- **C3** - Open Permeate Valve stage

**06 - (Rinse New UFL Membrane)**

- Operator runs the 06 program (see Service Menu Access above)
- The system runs the **07 - (Depressurize UFL System)** program (see below)
- The system displays **d3**. **Operator** - after beep, manually open the Rinse Ball Valve and Inlet Ball Valve. Press **FLUSH**.
- **R1 stage: Operator** - wait for 1 minute. The system beeps. Press **FLUSH**.
- **R2 stage: Operator** - wait for 15 minutes. The system beeps. Manually close the Rinse Ball Valve. Press **FLUSH**.
- **R3 stage: Operator** - wait for 15 minutes. Manually open the Rinse Ball Valve. Press **FLUSH**.
- **R4 stage: Operator** - Wait for 5 minutes. The system beeps. Manually close the Rinse Ball Valve. Press **FLUSH**.
- **R5 stage: Operator** - Wait for 1 minute as the system automatically opens the Drain Valve.
- **R6 stage:** The system closes the Inlet Valve - the system is depressurized.
- **D3 stage: Operator** - Activate the **08 - (Pressurize System)** program.

**07 - (Depressurize UFL System)**

- **D1** Close Inlet Valve stage
- **D2** Open Drain Valve stage
- **D3** Close Permeate Valve stage

**08 - (Pressurize System)**

- **P1** - Close Drain Valve stage
- **P2** - Open Inlet Valve stage
- **P3** - Open Permeate Valve stage

**TROUBLESHOOTING**

<b>Problem</b>	<b>Possible Cause</b>	<b>Corrective Action</b>
Unit does not have power.	The power cord is not plugged into the appropriate outlet or control box.	Plug power cord into the appropriate outlet.
	The unit is plugged into a switched electrical outlet.	Plug the power cord into an unswitched outlet.
	SMART Controller Control Board is inoperable.	Contact your maintenance person or Authorized Service Agency.
	Transformer is defective.	
No water comes out of the filter system.	Inlet/Outlet Ball Valves closed.	Open the Inlet/Outlet Ball Valves.
	System depressurized.	Run System Pressurize program.
	Drain Valve is stuck open.	Clean, rebuild, and/or replace the Drain Valve.
	Rinse Ball Valve is open.	Close the Rinse Ball Valve.
	The system may be in a flush cycle.	Wait for the flush cycle to end.
	Wiring Harness incorrectly connected to solenoid valves.	Confirm wiring harness connections.
	Wiring harness has broken wire/ connection.	Repair or replace the wiring harness.
	Inlet Strainer (if installed) is plugged.	Clean or replace Inlet Strainer
	Ultra Filtration Cartridge is plugged.	Replace Ultra Filtration Cartridge.
	Carbon Elements are plugged.	Replace Carbon Elements.
Low water flow comes out of the filter system.	See above.	See above.
	The inlet water pressure is too low.	Boost the inlet water pressure.
	The outlet check valve may be plugged or defective.	Clean or replace the outlet check valve assembly.
	The inlet flow restrictor may be plugged.	Clean or replace the inlet flow restrictor.
Water tastes bad.	Carbon Elements need replacing.	Replace Carbon Elements.
	Storage/shipping solution not completely flushed out of the system.	Flush the system for a longer period of time; replace Carbon Elements.
	Biological growth in pipes.	Sanitize plumbing.
	Water condition changed.	Consider installing additional filtration.
	Broken capillaries in Ultra Filtration Cartridge.	Replace Ultra Filtration Cartridge.
Flush runs continuously.	Drain Valve stuck open.	Clean, rebuild, or replace the Drain Valve.
	Controller sending continuous signals to valves.	Replace the controller.

**MAINTENANCE (continued)**

<b>Problem</b>	<b>Possible Cause</b>	<b>Corrective Action</b>
Flush runs too long. [Factory set single flush cycle is 1 minute; up to 3 consecutive cycles possible (total 3 minutes)]	Flush settings changed from factory setting.	Confirm flush settings; change back to factory settings.
	Inoperable SMART Controller.	Replace the SMART Controller.
Flush occurs at a time of high water usage.	The controller time clock is set incorrectly or setting was lost due to power loss.	Set time clock to correct time.
	Flush time set wrong.	Set flush time to acceptable time.
Water splashes at drain during flush.	Drain line not positioned properly.	Reposition the end of the drain line.
	Drain not capable of handling high flow rate.	Clean drain; find alternate drain.
Water leaks at ends of the filter cartridge after changing cartridge.	O-ring not lubricated.	Lubricate O-ring with food grade lubricant.
	O-ring is split, cut, or twisted.	Replace O-ring.
	Cartridge end connections are loose.	Tighten with wrench; replace fittings if needed.
Water leaks from Carbon bowl.	O-ring not lubricated.	Lubricate O-ring with food grade lubricant.
	O-ring is split, cut, or twisted.	Replace O-ring.
Water leaks from system fitting or connection.	Fitting broken or loose.	Tighten or replace the fitting.
	Not enough pipe thread sealant used.	Redo the fitting with the proper amount of sealant.

**WIRING DIAGRAM**

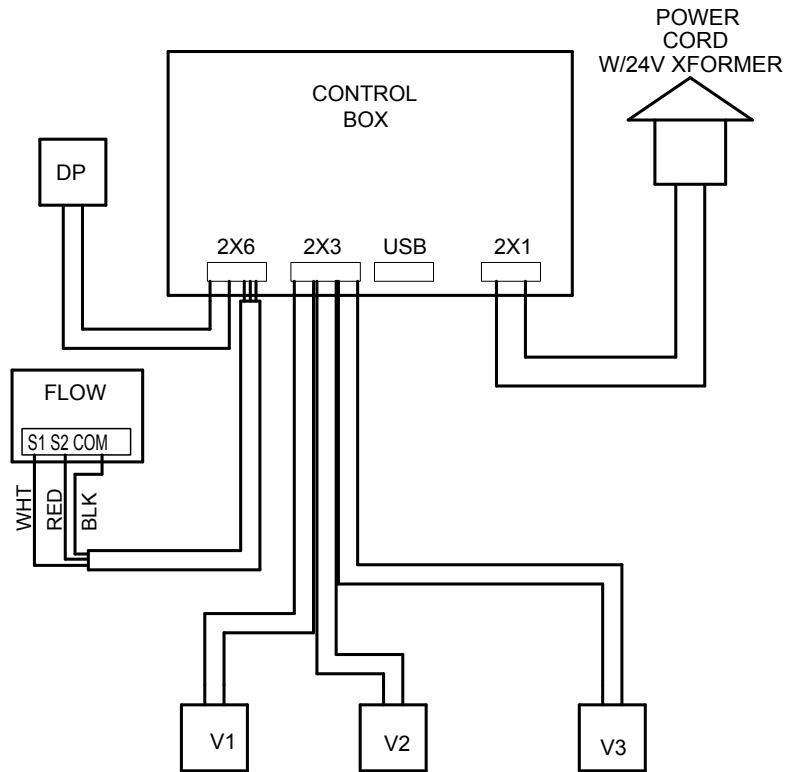

**RECOMMENDED EQUIPMENT SCHEMATIC**

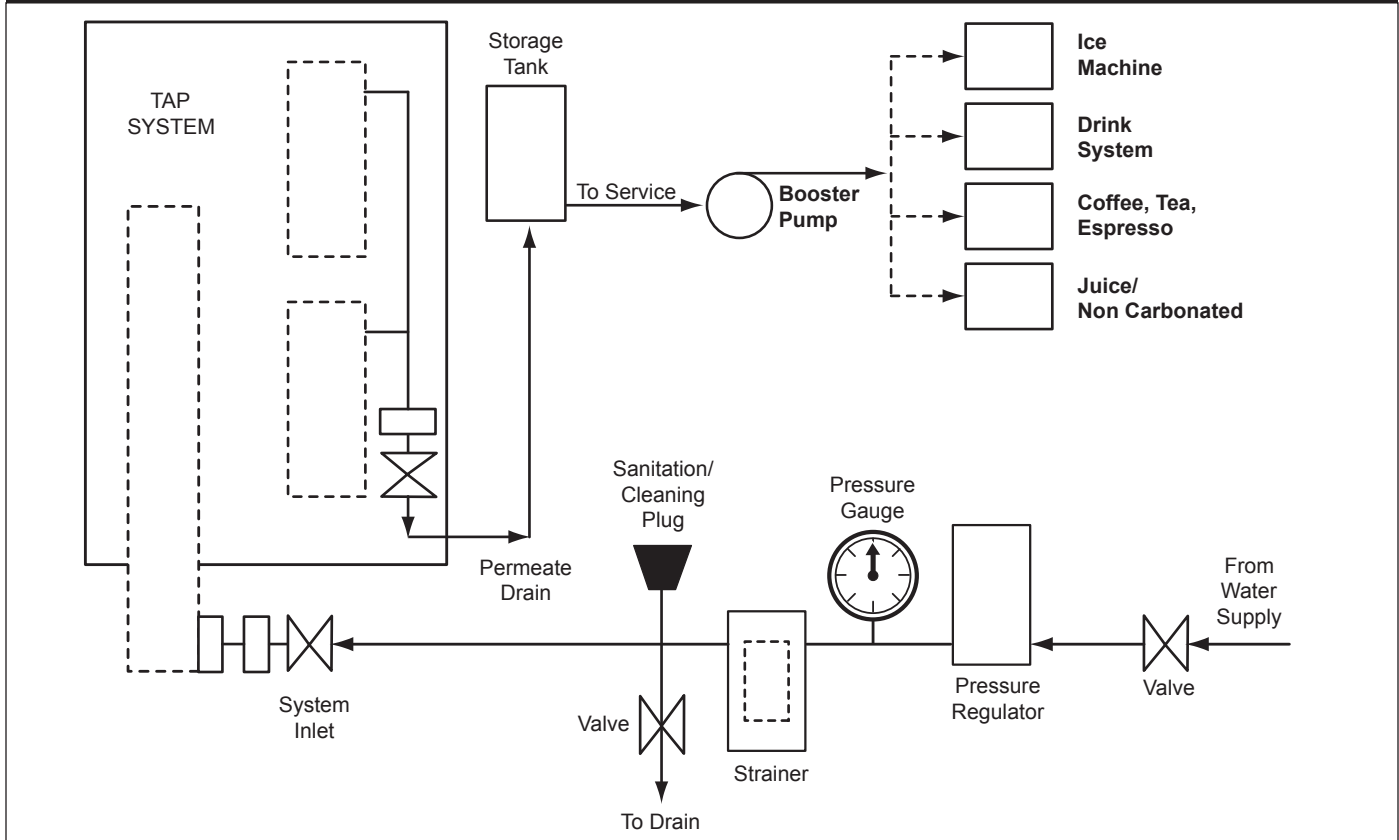

**REPLACEMENT PARTS**

**TAP-442 only**

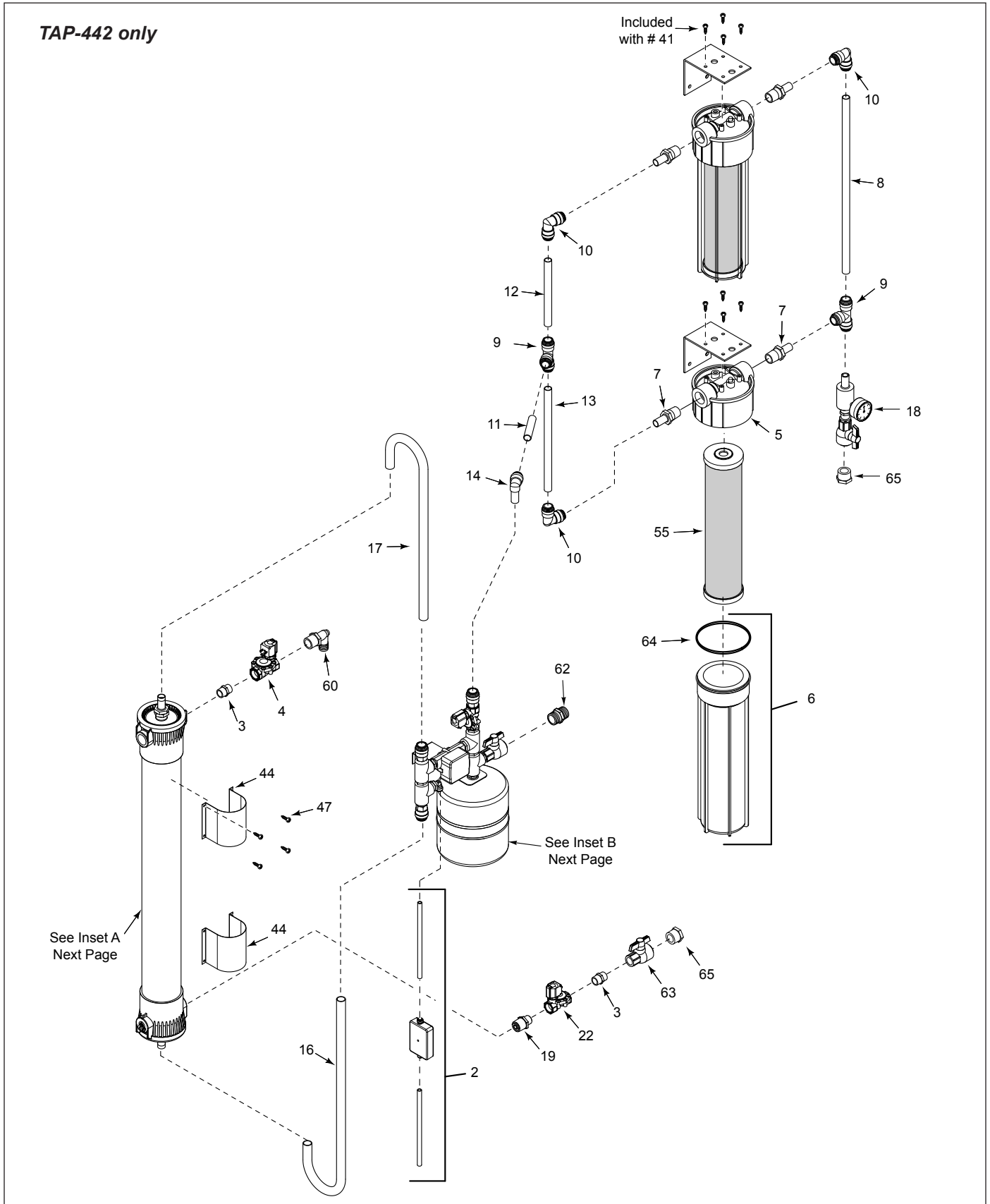

**REPLACEMENT PARTS (continued)**

*TAP-442 only*

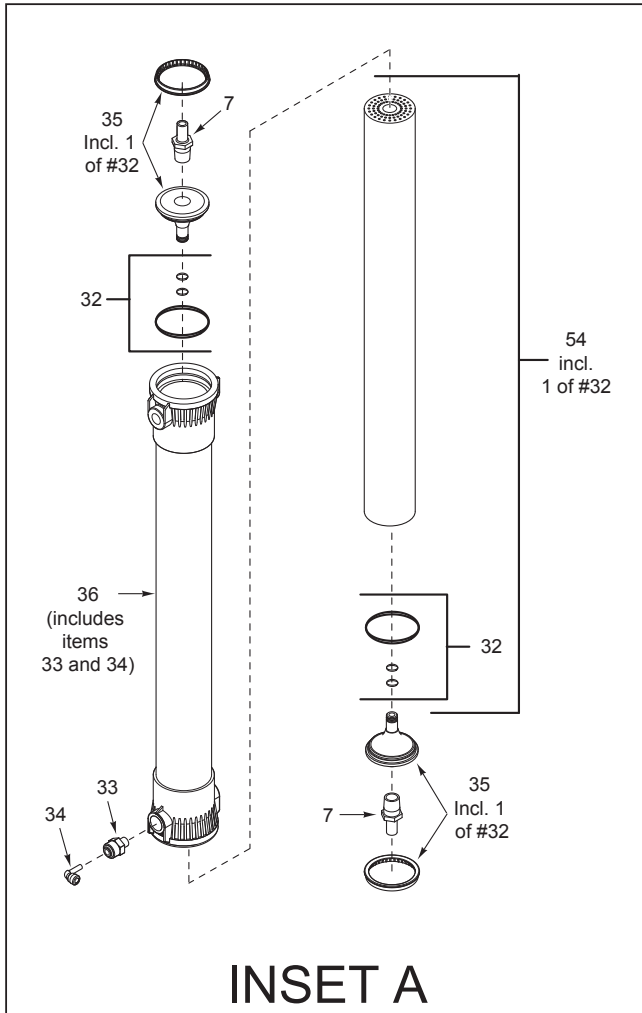

**INSET A**

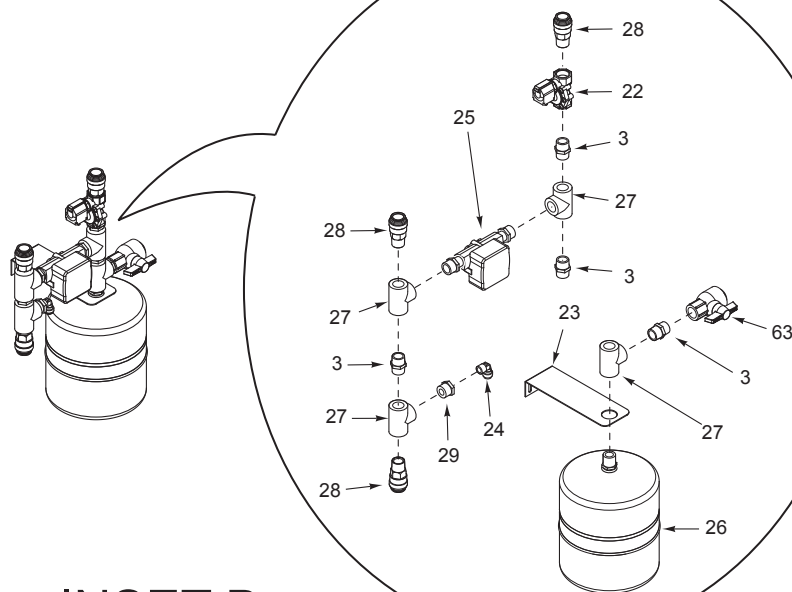

**INSET B**

**REPLACEMENT PARTS (continued)**

**TAP-442 only**

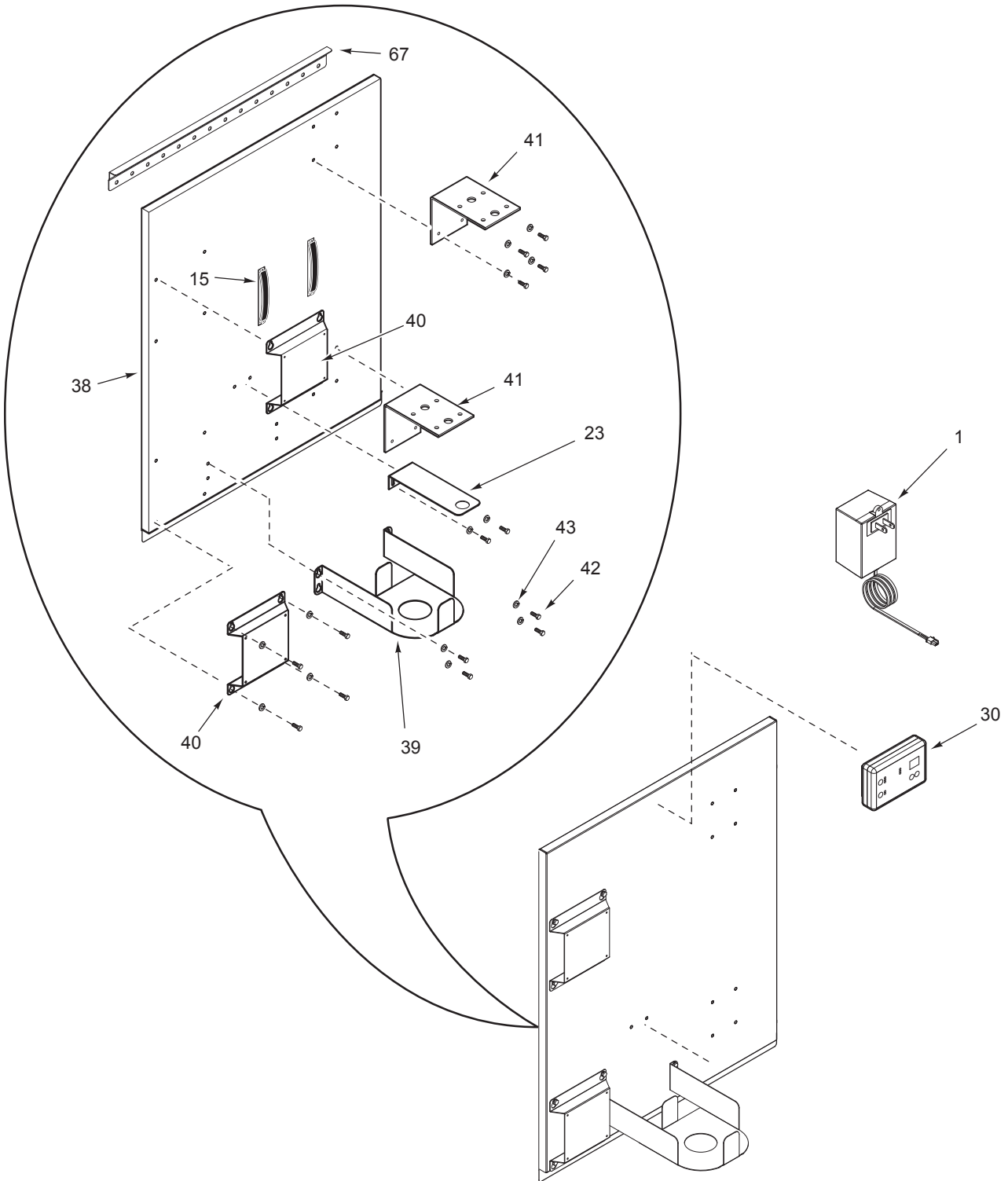

**REPLACEMENT PARTS (continued)**

Replacement Parts can be purchased from an authorized dealer. Contact Antunes Filtration Technologies at 1-630-754-1000 or toll free in the United States at 1-800-253-2991

Item No.	Part No.	Description	Qty.
1	0012146	DC Power Supply with Adaptors	1
2	7000527	TAP Pressure Differential Kit	1
3	2190144	Nipple, Hex 3/4" NPT X 1 1/2" Lg	7
4	4040182	Solenoid Valve Latching w/ Spring	1
5	2180220	Head, Carbon (TAP System)	1
6	2180221	Carbon Housing and O-ring, Clear	1
	2180282	Carbon Housing and O-ring, White	
7	2190154	Adaptor, 1" Stem	6
8	2010134	Tubing, Pex, 7/8" 25" Lgth	1
9	2190155	Union Tee	2
10	2190156	Union Elbow	3
11	2010131	Tubing, Pex, 7/8" OD 4" Lgth	1
12	2010132	Tubing, Pex, 7/8" OD 9.25" Lgth	1
13	2010133	Tubing, Pex, 7/8" OD 14.5" Lgth	1
14	2190159	Stackable Elbow	1
15	2100312	Handle, AFT (Back Plate)	2
16	2010158	Tubing, UFL Bottom	1
17	2010157	Tubing, UFL Top	1
18	7000529	Outlet Check Valve Kit	1
19	7000549	Flow Regulator Assy Kit - 10 GPM	1
22	4040181	Solenoid Valve Latching w/o Spring	2
23	0504309	Tank Support	1
24	2080132	Elbow, Fixed, 3/8" Tube OD X 1/4" NPT Thread	1
25	2170125	TAP Water Meter	1
26	2180215	Tank, 2.1 Gallon, 3/4" NPT	1
27	2180272	Tee 3/4" NPT	4
28	2190157	Male Connector 3/4" NPT	3
29	2180271	Cross, Tank Block	1
30	7000545	TAP DC Smart Controller	1
31	1001197	Label, TAP System Control Cover	1
32	7000413	O-Ring Replacement Kit	1
33	2080125	Connector, Male, 1/4" Tube OD X 1/8" NPT Thrd	1
34	2080126	Elbow, Plug-in, 1/4" Stem OD X 1/4" Tube OD	1
35	2180230	End Cap 4" Quick Connect	2
36	2180222	Housing, Filter, 440 W/sensor Port	1
38	0021484	Weldment Tap Plate	1
39	0504581	Saddle	1

Item No.	Part No.	Description	Qty.
40	0504279	Bracket, Mounting	2
41	0504359	Bracket, Carbon Filter Head	2
42	325P109	Screw, #1/4-20 X 1/2" Hex Head Pack	22
43	325P154	Washer, Lock 1/4" S/S Helical Spring, Regular	22
44	0504065	Clamp, 4" Filter UFL	2
45*	0700712	Wire Harness, TAP Valve Control	1
46*	0700713	Wire Harness, TAP (Pressure/flow)	1
47	325P157	Screw, #1/4-20 X1/2" Mach. Head Pack	8
48*	1001133	Label, Inlet	1
49*	1001134	Label, Permeate	1
50*	1001135	Label, Drain	1
51*	1010941	Quick Reference Card TAP	1
52*	1010942	Owner's Manual TAP-44X Family	1
53*	1030863	Spec Label #9700700	1
54	7000412	Cartridge Replacement Kit	1
55	7000669	Carbon Element Kit (Single Pk)	1
56*	2110176	Clamp, Worm 7/8" Dia To 1 1/4" Hose Dia.	2
57*	2140153	Lubricant, Dow Corning High-Vacuum Grease	1
58*	2140158	Cord, Loctite Thread Sealing	1
59*	2180226	Filter Wrench (For Giant 20" Housing)	1
60	2190163	Fitting-Elbow, 3/4-npt To 3/4" Hose Barb	2
61*	5206019	Tubing, Braided Pvc 20ft	1
62	2190167	Adapter, 3/4" Garden Hose	1
63	2170131	Valve, Ball, 3/4" NPT Female to 3/4" NPT Male	3
64	0200261	O-Ring, Carbon Bowl (Housing)	1
67	0505558	Mounting Bracket	1
68*	1001209	Label, OEM Carbon Replacement	2
69	0400381	Grommet, 1.75 OD x 1.187 ID	1
70	0400387	Grommet, Support, Small	2
71	0504600	Bracket, Support - Outlet	1
72	0504597	Bracket, Mounting	1
73	2180181	Ring, Lock	2
<b>* Not Shown</b>			



## LIMITED WARRANTY

Equipment manufactured by the Antunes Filtration Technologies Division of A.J. Antunes & Co. has been constructed of the finest materials available and manufactured to high quality standards. These units are warranted to be free from defects in materials and workmanship for a period of one year from date of purchase under normal use and service, and when installed in accordance with manufacturer's recommendations\*. The ultra filtration membrane cartridge is warranted under the same terms and conditions on a prorated basis for 24 months from date of purchase.

\*To ensure continued proper operation of the units, follow the maintenance procedure outlined in the Owner's Manual.

1. This warranty does not cover failures due to improper system installation, defects caused by improper storage or handling prior to placing of the equipment into service. This warranty does not include overtime charges or work done by unauthorized service agencies or personnel. This warranty does not cover normal maintenance, calibration, or regular adjustments as specified in operating and maintenance instructions of this manual, and/or labor involved in moving adjacent objects to gain access to the Equipment.
2. Antunes Filtration Technologies reserves the right to make changes in design or add any improvements on any product. The right is always reserved to modify equipment because of factors beyond our control and government regulations. Changes to update equipment do not constitute a warranty charge.
3. **If shipment is damaged in transit, the purchaser should make a claim directly upon the carrier. Careful inspection should be made of the shipment as soon as it arrives and visible damage should be noted upon the carrier's documentation. Damage should be reported to the carrier. This damage is not covered under this warranty.**
4. THIS WARRANTY IS EXCLUSIVE AND IS IN LIEU OF ALL OTHER WARRANTIES, EXPRESSED OR IMPLIED, INCLUDING ANY IMPLIED WARRANTY OR MERCHANTABILITY OR FITNESS FOR A PARTICULAR PURPOSE, EACH OF WHICH IS HEREBY EXPRESSLY DISCLAIMED. THE REMEDIES DESCRIBED ABOVE ARE EXCLUSIVE AND IN NO EVENT SHALL ANTUNES FILTRATION TECHNOLOGIES BE LIABLE FOR SPECIAL CONSEQUENTIAL OR INCIDENTAL DAMAGES FOR THE BREACH OR DELAY IN PERFORMANCE OF THIS WARRANTY.

Prices and specifications are subject to change without notice.



A.J. Antunes & Co.  
Headquarters/Manufacturing  
180 Kehoe Boulevard  
Carol Stream, Illinois 60188 USA  
Phone (630) 784-1000  
Toll Free (800) 253-2991  
Fax: (630) 784-1650

Antunes Equipment  
Manufacturing (Suzhou) Ltd.,  
9 Hou Ju Road, Building #24,  
S&T Park, SND  
Suzhou, Jiangsu, China 215011  
Phone: 86-512-6841-3637  
Fax: 86-512-6841-3907

[www.ajantunes.com](http://www.ajantunes.com)