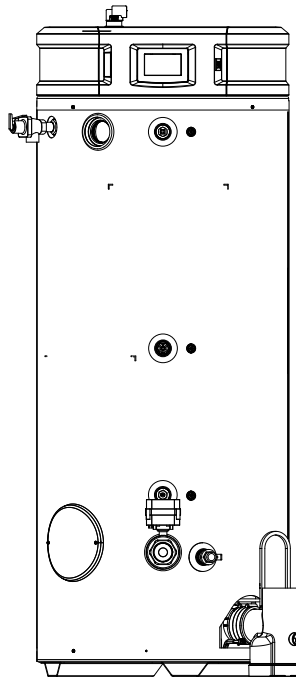


# Commercial High Efficiency Water Heater

# USE & CARE MANUAL

WITH INSTALLATION INSTRUCTIONS FOR THE CONTRACTOR

For use with the following models:  
GHE80SS, GHE80SU  
GHE100SS, GHE100SU  
CATEGORY IV Models  
Fan Assisted Combustion



Recognize this symbol as an indication of important safety information!



Do not destroy this manual. Please read carefully and keep in a safe place for future reference.



**NOTICE:** This water heater is designed for use in a commercial application and the installation and maintenance of it should be performed by a qualified, licensed service professional. If the foregoing assumption is not appropriate, then we recommend that you obtain and retain our Residential Use & Care Manual.



**WARNING:** If the information in these instructions are not followed exactly, a fire or explosion may result causing property damage, personal injury or death.

## **⚠ FOR YOUR SAFETY!**

### **-AVOID FIRES AND EXPLOSIONS**

- Do not store or use gasoline, other flammable vapors or liquids or other combustible materials in the vicinity of this or any other appliance.
- Doing so may result in a explosion or fire

### **- WHAT TO DO IF YOU SMELL GAS**

- Do not try to light any appliance.
- Do not touch any electrical switch.
- Do not use any phone in your building
- Immediately call your gas supplier from a neighbor's phone. And follow the gas supplier's instructions.

- If you cannot reach your gas supplier, call the fire department.

- Do not return to your building until authorized by the gas supplier or fire department.

### **-ALWAYS REFER TO THIS MANUAL**

- Improper installation, adjustment, alteration, service, or maintenance can cause injury, property damage, or death.
- Installation and service must be performed by a qualified installer, service agency, or gas supplier.

## TABLE OF CONTENTS

### Safety Information

Safety Precautions ..... 3-4

### Introduction

Local Installation Regulations ..... 5

Water Heater Location ..... 5

### Installation Instructions

Inspect Shipment ..... 5

Water Supply Connections ..... 6

Gas Supply..... 6

Wiring ..... 7

Typical Installation..... 8

### Vent Installation

Information for Pipe and Fittings..... 9

General Venting Information ..... 9

Joining Pipe and Fittings ..... 9-10

Vent Length Information..... 11-12

Vent Terminal Precautions ..... 13-16

Horizontal Vent Installation..... 17-19

Vertical Vent Installation ..... 20-22

Concentric Vent Installation..... 23-29

Installation Checklist..... 30

### Operating Instructions

Ignition Instructions ..... 31

Water Temperature ..... 32

Emergency Shut Down..... 32

User Interface .....33-39

### Care and Cleaning

Pressure Switch Inspection ..... 37

Venting Inspection..... 37

Routine Maintenance ..... 37

Anode Inspection ..... 37

Seasonal Operation ..... 37

Venting System Inspection..... 37

### Troubleshooting

Before You Call For Service..... 38-46

Alarm and Alert Codes .....40-46

### Customer Service

Parts List ..... 47

Wiring Diagrams ..... 48

How to Obtain Service Assistance ..... 52

## READ ALL SAFETY INFORMATION

Your safety and the safety of others are very important. There are many important safety messages in this manual and on your appliance. Always read and follow all safety messages.



This is the safety alert symbol. Recognize this symbol as an indication of important safety information! This symbol alerts you to safety hazards that could result in physical harm or death.

All safety messages will follow the safety alert symbol and either the word “DANGER”, “WARNING”, “CAUTION” or “NOTICE”.

These words mean:

### DANGER

An imminently hazardous situation that will result in death or serious injury.

### WARNING

A potentially hazardous situation that could result in death or serious injury and/or damage to property.

### CAUTION

A potentially hazardous situation that may result in minor or moderate injury.

### NOTICE:

Attention is called to observe a specified procedure or maintain a specific condition.

#### Quick Guide for Water Heater Operating Conditions:

##### Min. Inlet Gas Pressure (at gas valve, during ignition to full input):

Natural Gas:	3.5 In. WC
LP Gas:	11.0 In. WC

##### Max. Inlet Gas Pressure (at gas valve, during ignition to full input):

Natural Gas:	10.5 In. WC
LP Gas:	13.0 In. WC

##### Electrical:

120 Vac, 60 Hz., 7 amp min. powered required

##### Basic Clearances for Water Heaters:

To combustibles: 0" for sides and back; 6" for top  
Recommended for service: 24" for front and top



# General Safety Precautions

To meet commercial water use needs, the temperature on this water heater is adjustable up to 185°F (85° C). However, water temperatures over 125°F (52° C) can cause severe burns instantly or death from scalds. This is the preferred starting point for setting the control for supplying general purpose hot water.

Safety and energy conservation are factors to be considered when setting the water temperature. The most energy efficient operation will result when the temperature setting is the lowest value that satisfies the needs consistent with the application.

The following chart details the relationship of water temperature and time to scald injury and may be used as a guide in determining the safest water temperature for your applications.

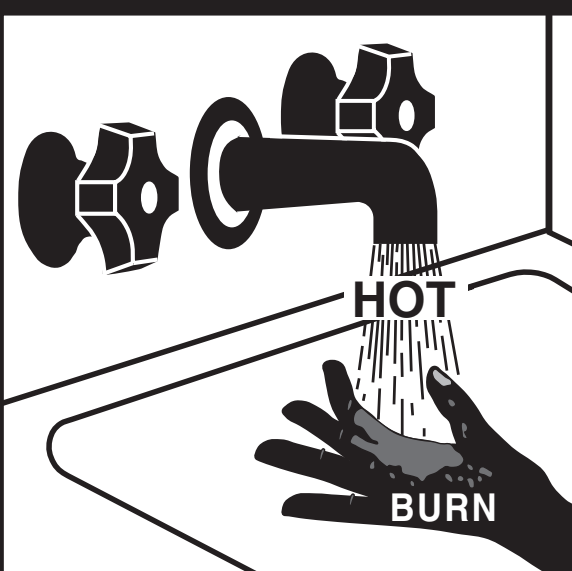
TIME / TEMPERATURE RELATIONSHIPS IN SCALDS

Temperature	Time to Produce Serious Burn
120° F (49°C)	More than 5 minutes
125° F (52°C)	1 <sup>1</sup> / <sub>2</sub> to 2 minutes
130° F (54°C)	About 30 seconds
135° F (57°C)	About 10 seconds
140° F (60°C)	Less than 5 seconds
145° F (63°C)	Less than 3 seconds
150° F (66°C)	About 1 <sup>1</sup> / <sub>2</sub> seconds
155° F (68°C)	About 1 second

Table courtesy of Shriners Burn Institute

The temperature of the water in the heater can be regulated by setting the temperature on the display (see pages 33 & 36). To comply with safety regulations the water heater temperature was set to 120°F (49°C) before the water heater was shipped from the factory. The illustration information on pages 33 & 36 shows the display and how to adjust the water temperature.

**! DANGER**



**Water temperature over 125°F can cause severe burns instantly or death from scalds.**

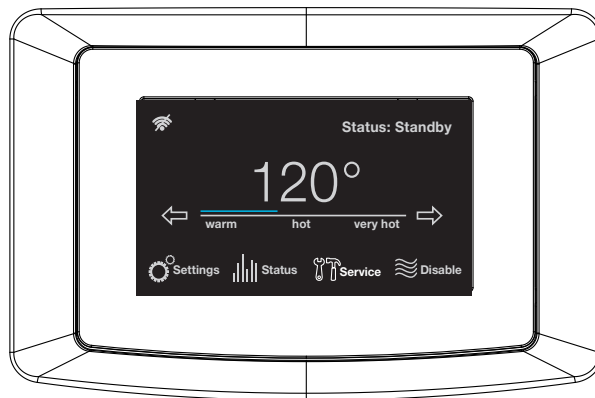
**Children, disabled and elderly persons are at greatest risk of being scalded.**

**See instructions manual before setting temperature of water heater.**

**Turn water off before bathing or showering.**

**Temperature limiting valves are available, see manual.**

## ! DANGER



See Section "User Interface" (pages 33 & 36) for setting the temperature.

Hotter water increases the potential for hot water SCALDS. **NOTICE:** Mixing valves are recommended for reducing point of use water temperature by mixing hot and cold water in branch water lines. It is recommended that a mixing valve complying with the Standard for Temperature Actuated Mixing Valves for Hot Water Distribution Systems, ASSE 1017 be installed. See page 6 for more details. For additional information, contact a licensed plumber or the local plumbing authority.

Maximum water temperatures occur just after burner has shut off. To find the temperature of the hot water being delivered, turn on a hot water faucet, and place a thermometer in the hot water stream, and read the thermometer.



# General Safety Precautions

Be sure to read and understand the entire Use & Care Manual before attempting to install or operate this water heater. Especially the following General Safety Precautions. Failure to follow these warnings could result in a fire or explosion, causing property damage, bodily injury, or death. Should you have any problems understanding the instructions in this manual, STOP, and get help from a qualified installer, service technician, or gas supplier.

## WARNING

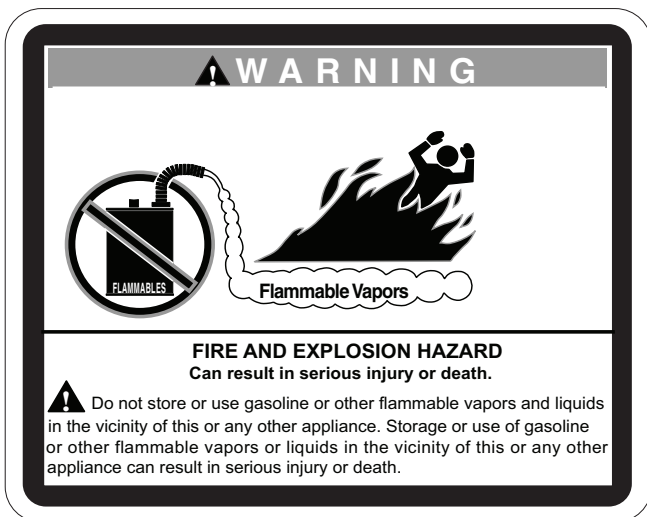
Gasoline, as well as other flammable materials and liquids (adhesives, solvents, etc.) and the vapors they produce, are extremely dangerous. DO NOT handle, use or store gasoline or other flammable or combustible materials anywhere near or in the vicinity of a water heater. Be sure to read and follow the warning label pictured below as well as the other labels on the water heater, and warnings printed in this manual. Failure to do so can result in property damage, bodily injury, or death.

## DANGER

Failure to properly vent the water heater to the outdoors as outlined in the "Venting" section (see pages 8 through 29) of this manual can result in unsafe operation of the water heater. To avoid the risk of fire, explosion, or asphyxiation from carbon monoxide, never operate this water heater unless it is properly vented and has an adequate air supply for proper operation. Be sure to inspect the vent system for proper installation at initial start-up and, at least, annually, thereafter. Refer to the "Maintenance" section (see page 37) of this manual for more information regarding vent system inspections.

## WARNING

Gasoline, as well as other flammable materials and liquids (which include but are not limited to adhesives, solvents, paint Thinners, etc.), and the vapors they produce are extremely dangerous. DO NOT handle, use, or store gasoline or other flammable or combustible materials anywhere near or in the vicinity of a water heater or any other appliance. Be sure to read and follow the warning label pictured below and other labels on the water heater and in this manual. Failure to do so can result in property damage, bodily injury, or death.



## DANGER

**LIQUEFIED PETROLEUM MODELS — Propane (LP) gas, must be used with great caution.**

- It is heavier than air and will collect first in lower areas making it hard to detect at nose level.
- Make sure to look and smell for LP leaks before attempting ignition of the water heater. Use a soapy solution to check all gas fittings and connections. Bubbling at a connection indicates a leak that must be corrected.
- When smelling to detect an LP leak, be sure to sniff near the floor too.
- Gas detectors are recommended in LP applications and their installation should be in accordance with the manufacturer's recommendations and local laws, rules, regulations, or customs.
- It is recommended that more than one method be used to detect leaks in LP applications.

### IF LP GAS IS PRESENT OR SUSPECTED:

- DO NOT attempt to find the cause yourself;
- DO NOT try to light any appliance;
- DO NOT touch any electrical switch;
- DO NOT use any phone in your building.
- Leave the building immediately and make sure your family and pets leave also.
- Leave the doors open for ventilation and contact the gas supplier, a qualified service agency or the fire department.
- Keep the area clear until the service call has been made, the leak is corrected, and a qualified agency has determined the area to be safe. Read and Review this entire manual with special emphasis on the "Venting" section (Pages 8-29) and "Operation" section (Pages 31-32) prior to any installation work.

## WARNING

Both LP and natural gas have an odorant added to help detection. Some people may not physically be able to smell or recognize this odorant. If unsure or unfamiliar about the smell associated with LP or natural gas, ask the gas supplier. Other conditions, such as "Odorant Fade", which causes the odorant to "fade" or diminish in intensity can also hide or camouflage a gas leak.

## DANGER

Water heaters utilizing Liquefied Petroleum gas (LP) are different from natural gas models. A natural gas heater will not function safely on LP gas and vice versa. No attempt should ever be made to convert a heater from natural gas to LP gas. To avoid possible equipment damage, personal injury or fire: DO NOT connect this water heater to a fuel type not in accordance with the unit's data plate. Propane for propane units; natural gas for natural gas units. These units are not certified for any other type fuel.

## WARNING

LP appliances should not be installed below-grade (for example, in a basement) if such installation is prohibited by federal, state, or local laws, rules, regulations or customs.

# Introduction

## LOCAL INSTALLATION REGULATIONS

This water heater must be installed in accordance with these instructions, local codes, and utility company requirements. In the absence of local codes, the latest edition of the National Fuel Gas Code, ANSI Z223.1 in the United States, or CAN/CSA B149.1 Installation Codes in Canada should be consulted.

## LOCATION

A. If this water heater is of the direct vent, all air for combustion and all products of combustion are routed through the venting system, directly from the water heater to the outside of the building.

Otherwise, this unit can also be set up as a power vent unit. Combustion air for a power vent unit will be obtained from the surrounding area. Ensure that there is an adequate air supply for the water heater, per the codes given above in the "Local Installation Regulations" section.

The water heater should be installed in a clean, dry location as close as practical to the vent terminals. Long hot water lines should be insulated to conserve water and energy. The water heater and water lines should be protected from exposure to freezing temperatures.

B. A gas fired water heater should not be installed in a space where liquids which give off flammable vapors are to be used or stored. Such liquids include gasoline, LP gas (butane and propane), paint or adhesives and their thinners, solvents or removers. Because of natural air movement in a room or other enclosed space, flammable vapors can be carried some distance from where their liquids are being used or stored. The open flame of the water heater's main burner can ignite these vapors causing an explosion or fire which may result in severe burns, death, or property damage. For these reasons, installation of a gas-fired water heater in a garage is not desirable.

C. All models are certified for installation on combustible floors and in alcoves. The minimum side and top clearance to walls and ceiling for providing protection of combustible materials are shown on the water heater's rating label. A top and front clearance of 24 inches (61 cm) is recommended for inspection and servicing.

**NOTICE: Auxiliary catch pan installation MUST conform to the applicable local codes.**

### CAUTION

The water heater should not be located in an area where leakage of the tank or connections will result in damage to the area adjacent to it or to lower floors of the structure. When such areas cannot be avoided, it is recommended that a suitable catch pan be installed under the water heater and adequately drained. The pan **MUST NOT** interfere with the operation of the water heater and access of the serviceable components.

D. **RESTAURANT INSTALLATION:** — If the water heater is to be installed in a restaurant or other location where NSF International listing is required, this unit must be sealed to the floor, and other components must be added utilizing Rheem's UL listed NSF seal Kit (see kit listing on page 34). A factory designed

sealing kit is available from the distributor or store where the water heater was purchased. When installed according to the instructions supplied with the kit, these heaters will meet the NSF international requirements.

E. **CORROSIVE ATMOSPHERES** — The heater should not be installed near an air supply containing halogenated hydrocarbons. For example, the air in beauty shops, dry cleaning establishments, photo processing labs, and storage areas for liquid and powdered bleaches or swimming pool chemicals often contain such hydrocarbons. The air there may be safe to breathe, but when it passes through a gas flame, corrosive elements are released that will shorten the life of any gas burning appliance. Propellants from common spray cans or gas leaks from refrigeration equipment are highly corrosive after passing through a flame. The limited warranty is voided when failure of the water heater is due to a corrosive atmosphere. (Refer to the Certificate of Limited Warranty for complete terms and conditions.) The manufacturer's warranty does not cover any damage or defect caused by installation, attachment, or use of any special attachment, such as energy saving devices (other than those authorized by the manufacturer) into, onto, or in conjunction with the water heater. The use of such unauthorized devices may shorten the life of the water heater and may endanger life and property. The manufacturer disclaims any responsibility for such loss or injury resulting from the use of such unauthorized devices.

1. **INSPECT SHIPMENT** — Check for possible damage that may have occurred during shipping. The manufacturer's responsibility ceases upon delivery of goods to the carrier in good condition. Any claims for damage, shortage in shipments, or non-delivery must be filed immediately against the carrier by the consignee.

One plastic bag is included, contains the Use & Care Manual, and Warranty.

One box is included, contains the fitting plugs, 3 inch elbow w/screen, exhaust tee w/condensate trap and instructions to install the neutralizer.

2. **THERMAL EXPANSION** — Determine if a check valve exists in the inlet water line. It may have been installed in the cold water line as a separate back flow preventer, or it may be part of a pressure reducing valve, water meter or water softener. A check valve located in the cold water inlet line can cause what is referred to as a "closed water system". A cold water inlet line with no check valve or back flow prevention device is referred to as an "open" water system.

As water is heated, it expands in volume and creates an increase in the pressure within the water system. This action is referred to as "thermal expansion". In an "open" water system, expanding water, which exceeds the capacity of the water heater, flows back into the city main where the pressure is easily dissipated.

A "closed water system", however, prevents the expanding water from flowing back into the main supply line and the result of "thermal expansion" can create a rapid, and dangerous pressure increase in the water heater and system piping. This rapid pressure increase can quickly reach the safety

# Installation

setting of the relief valve, causing it to operate during each heating cycle. Thermal expansion, and the resulting rapid, repeated expansion and contraction of components in the water heater and piping system can cause premature failure of the relief valve and possibly the heater itself. Replacing the relief valve will not correct the problem!

The suggested method of controlling thermal expansion is to install an expansion tank in the cold water line between the water heater and the check valve. The expansion tank is designed with an air cushion built in that compresses as the system pressure increases, thereby relieving the over pressure condition and eliminating the repeated operation of the relief valve. Other methods of controlling thermal expansion are also available. Contact your installing contractor, water supplier, or plumbing inspector for additional information regarding this subject.

If a recirculation line is installed, the return connection should be made through a tee close to the inlet connection on the water heater. A check valve should always be installed in the recirculation line to prevent cold water from entering.

**WATER CONNECTIONS** — This water heater may be connected individually, in multiples with others, or with an external hot water storage tank.

Inlet water connections are made to the lower coupling on the heater, and outlet water connections are made to the upper coupling.

Each water heater is supplied with the necessary components (diffuser tubes) to make the water connections that will ensure proper performance. The components are supplied in a bag attached to the water heater. If special instructions are required for any specific water heater, they will be included in the bag.

Cap or plug unused connections. Use only clean, new galvanized steel, copper or approved plastic pipe for water connections. Local codes or regulations shall govern the exact type of material to be used.

The installation of unions on the inlet and outlet water lines and a shut-off valve in at least the cold water inlet line is recommended, so the water heater may be easily disconnected for servicing. Dielectric unions are not required for protection of the water heater.

**Mixing valves are recommended for reducing point of use water temperature by mixing hot and cold water in branch water lines. It is recommended that a mixing valve complying with the Standard for Temperature Actuated Mixing Valves for Hot Water Distribution Systems, ASSE 1017 be installed. See page 3 for more details and contact a licensed plumber or the local plumbing authority for further information.**

Thermometer(s) should be installed so that they indicate the temperature of the water at or near the outlet of the water heater and storage tank(s) if provided. See Fig. 2.

3. **RELIEF VALVE** — A new factory installed combination pressure and temperature relief valve, complying with the Standard for Relief Valves and Automatic Gas Shutoff Devices for Hot Water Supply Systems, ANSI Z21.22, or Standard CSA 4.4, Temperature, Pressure, Temperature and Pressure Relief Valves and Vacuum Relief Valves is provided with the water heater. No valve is to be placed between the relief valve and the water heater. For a circulating tank installation, the separate storage tank(s) must have similar protection. The pressure rating of the relief valve must not exceed 150 psi (1034 kPa) (160 psi for ASME models), the maximum working pressure as marked on the front of the water heater.

## **WARNING**

Connect the outlet of the relief valve to a suitable open drain. The discharge line must pitch downward from the valve to allow complete draining (by gravity) of the relief valve and discharge line, and be no smaller than the outlet of the valve. The end of the discharge line should not be threaded or concealed and should be protected from freezing. No valve of any type, restriction or reducer coupling should be installed in the discharge line. Local codes shall govern the installation of relief valves.

The Btu/h rating of the relief valve must equal or exceed the Btu/h input of the water heater as marked on its rating plate.

4. **GAS SUPPLY** — The inlet gas pressure to the water heater must not exceed 10.5" wc (2.6 kPa) for Natural gas and 13.0" wc (3.2 kPa) for L.P. gas. The minimum inlet gas pressure (with main burner on) is shown on the rating plate. Check to see if high or low gas pressure is present and then contact the gas company for correction.

The gas line should be of adequate size to prevent undue pressure drop (pressure should not drop more than 1.5", when going from standby to full blower speed condition). Sizing based upon information in Table 2, on page 24. No additional allowance is necessary for an ordinary number of fittings.

**NOTE: The minimum inlet gas pressure (at gas valve), during ignition to full input, should not be less than 3.5" WC for Nat. or 11" WC for LP.**

A ground joint union and manual shutoff valve should be installed in the gas line near the water heater so that the burner assembly may be easily removed. The shut-off valve must be readily accessible for turning on or off. See Fig. 2.

If a sediment trap is not incorporated as part of the appliance, a sediment trap shall be installed downstream of the equipment shutoff valve as close to the inlet of the appliance as practical at the time of the appliance installation. The sediment trap shall be either a tee fitting with a capped nipple in the bottom outlet or other device recognized as an effective sediment trap. See Fig. 2.

**LEAK TESTING** — The water heater and its gas connections **MUST** be leak tested at normal operating pressure before it is placed in operation. Turn ON

the manual gas shut-off valve near the water heater. Use a soapy water solution to test for gas leaks at all connections and fittings. Bubbles indicate a gas leak that must be corrected. The water heater factory connections to the gas valve should also be leak tested after placing the water heater in operation.

**NEVER** use open flame to test for gas leaks, as bodily injury or property damage could result.

**PRESSURE TESTING THE GAS SUPPLY SYSTEM** — The water heater and its manual gas shut-off valve **MUST** be disconnected from the gas supply piping system during any high pressure testing of that system at pressures in excess of 1/2 psi (14" WC, 3.5 kPa).

The water heater **MUST** be isolated from the gas piping system by closing the manual gas shut-off valve during any pressure testing of the gas supply piping at pressures equal to or less than 1/2 psi (14" WC / 3.5 kPa).

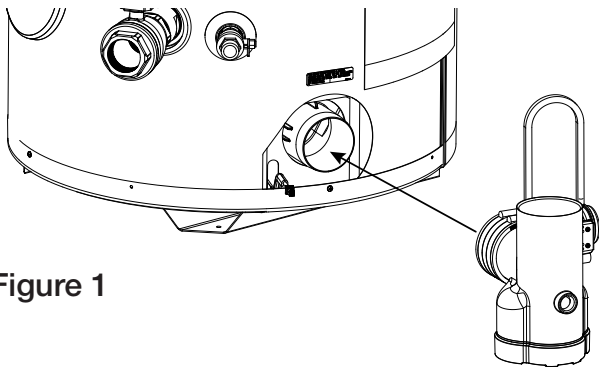


Figure 1

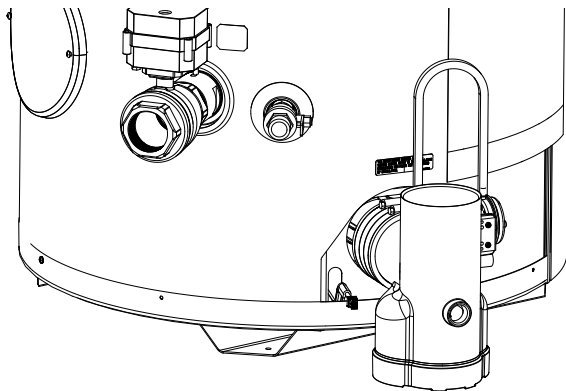


Figure 2 - Condensate Trap

Complete installation of wiring harnesses per installation instructions in kit.

## 5. CONDENSATE

**EXHAUST TEE & NEUTRALIZER** - The exhaust elbow/condensate trap is located in the installation kit along with the bag of neutralizer. Pour the neutralizer into the exhaust tee so that it is in the bottom. Then insert the exhaust tee onto the heater as shown in Figure 1. Using a 5/16" nut driver or ratchet, tighten the exhaust tee onto the heater.

**CONDENSATE** - This is a condensing high efficiency appliance and has a condensate removal system. The exhaust tee incorporates a condensate trap and must be filled with water before operating the water heater. Pour about 1 cup of water into the exhaust tee.

**SERVICING** - Remove the exhaust elbow from the heater using a 5/16" nut driver or ratchet. Empty the condensate and neutralizer from the exhaust elbow, and refill it with the new neutralizer (Rheem part number AP16770). Re-attach the exhaust tee to the heater. Pour approximately 1 cup of water into the exhaust tee. Re-attached the venting. It is very important that the condensate line is sloped away from the heater and down to a suitable inside drain. If the condensate outlet on this unit is lower than the drain, you must use a condensate removal pump. It is also important that the condensate line is not exposed to freezing temperatures, or any other type of blockage. Plastic tubing should be the only material used for the condensate line. Steel, brass, copper, or other metals will be subject to corrosion and deterioration, so they are not recommended to be used for the condensate drain line. A second vent may be necessary to prevent condensate line vacuum lock if a long horizontal run is used. Also an increase to 1" tubing may be necessary.

**6. WIRING** — A correct polarity 120V 50/60 Hz power supply with suitable disconnect means, must be connected to the black and white leads provided. The maximum current draw by these models is 7 Amps. The water heater, when installed, must be electrically grounded in accordance with local codes or, in the absence of local codes, with the National Electrical Code, ANSI/NFPA 70 in the United States, or CSA C22.1 Electrical Code, in Canada. Improper grounding or polarity may result in abnormal operation of the unit. Refer on page 48 of this manual for the wiring diagram for this water heater.

### **⚠ WARNING**

The water heater must be vented to the outdoors as described in these instructions.

### **⚠ WARNING**

**DO NOT** connect this water heater to an existing vent or chimney; it must be vented separately from all other appliances, using only approved venting materials.

# Installation

## **WARNING**

Failure to properly vent the water heater to the outdoors as outlined above and in the following section can result in unsafe operation of the water heater causing bodily injury, explosion, fire or death.

## **WARNING**

**NOTICE: DO NOT use in conjunction with a GFCI.** To avoid the risk of fire, explosion or asphyxiation from carbon monoxide, NEVER operate this water heater unless it is properly vented and has an adequate air supply for proper operation. It is important that the vent pipe engages fully into any pipe fitting and be kept in that position until the adhesive has fully cured. DO NOT drill or punch holes in the plastic pipe or fittings.

## 7. VENTING –

**NOTE:** This unit can be vented either as a direct vent or power vent configuration.

**NOTICE:** This unit can be vented using only the below recommended pipe material. Use only 2, 3, 4, or 6 inch diameter pipe.

Refer to local codes for restrictions on the use of PVC, CPVC, PP or ABS pipe and fittings. All exhaust venting materials for products installed in Canada must meet ULC-S636.

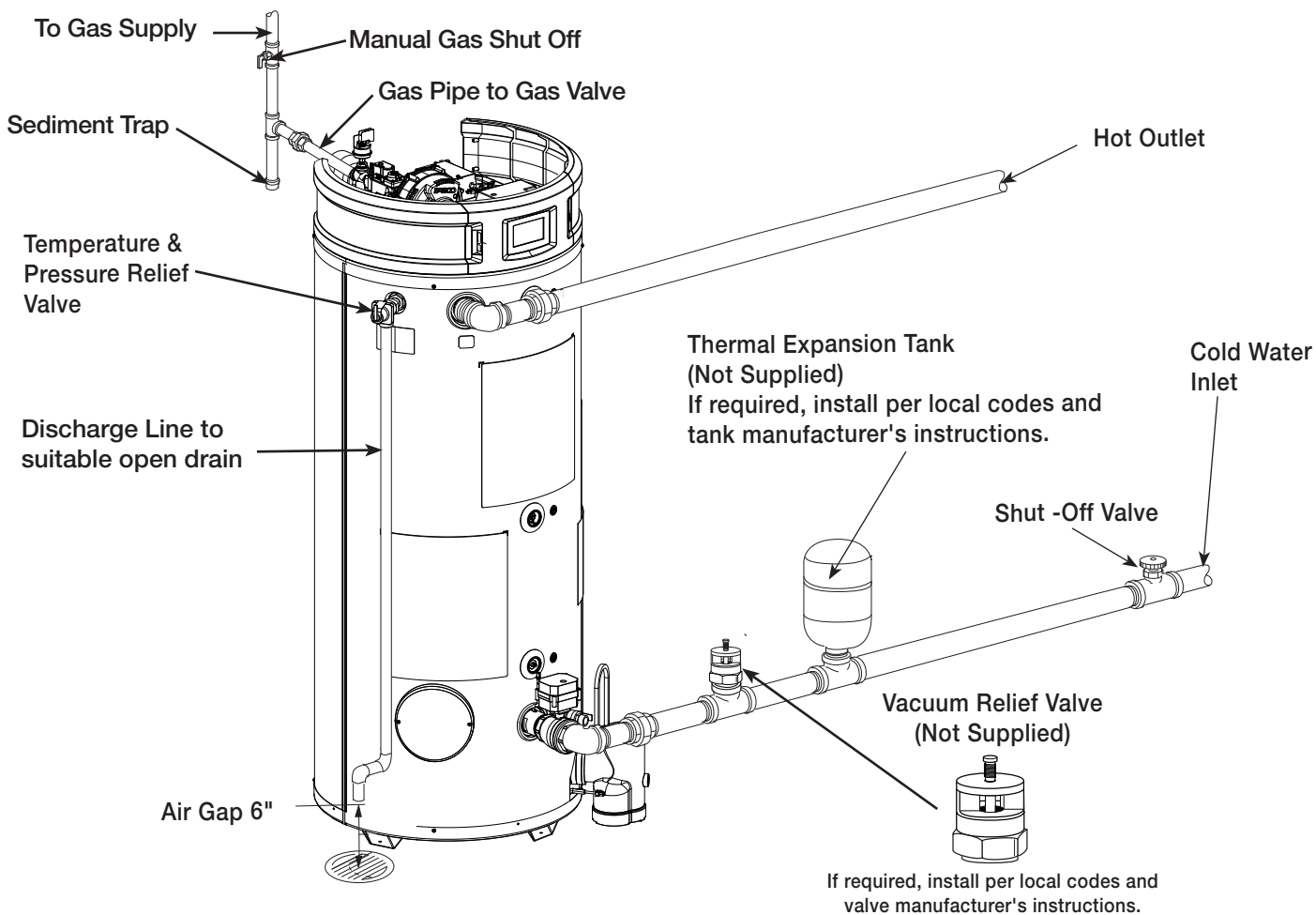
PVC (Schedule 40, ASTM D-1785)  
CPVC (Schedule 40, ASTM F-441)  
ABS (Schedule 40, ASTM D-2661)(Not permitted in Canada)

PVC Cellular Core (Schedule 40, ASTM F-891)(Not permitted in Canada)

The fittings, other than the VENT TERMINAL, should be equivalent to the following:

PVC (Schedule 40 DWV, ASTM D-2665)

Figure 3. – Typical Installation Drawing.



## NOTES:

The gas supply piping must be adequately supported and aligned to minimize loads (forces) on the water heater's gas valve and burner system.

# Installation

CPVC (Schedule 40 DWV, ASTM F-438)  
ABS (Schedule 40 DWV, ASTM D-2661)(Not permitted in Canada)

**NOTICE: Use of PVC cellular core (ASTM-F891), ABS Schedule 40, DWV cellular core (ASTM -F628), or Radel® (polyphenylsulfone) in non-metallic venting systems is prohibited.**

The unit may be vented horizontally through a wall or vertically through the roof. Pipe runs must be adequately supported along both vertical and horizontal runs. Maximum unsupported span is recommended to be no more than 4 feet. It is imperative that the first hanger be located on the horizontal run immediately adjacent to the first 90-degree elbow from the vertical rise or at the blower outlet, in the case of a horizontal blower position. The support method used should isolate the vent pipe from floor joists or other structural members to help prevent the transmission of noise and vibration. **DO NOT** support, pin, or otherwise secure the venting system in a way that restricts the normal thermal expansion and contraction of the chosen venting material.

If the water heater is being installed as a replacement for an existing power vented water heater, a thorough inspection of the existing venting system must be performed prior to any installation work. Verify that the correct materials, as detailed above, have been used and that the minimum or maximum vent length and terminal locations, as detailed in this manual, have been met. Carefully inspect the entire venting system for any signs of cracks or fractures, particularly at the joints between elbows or other fittings and the straight runs of vent pipe. Check the system for signs of sagging or other stresses in the joints as a result of misalignment of any components in the system. If any of these conditions are found, they must be corrected in accordance with the venting instructions in this manual before completing the installation and putting the water heater into service.

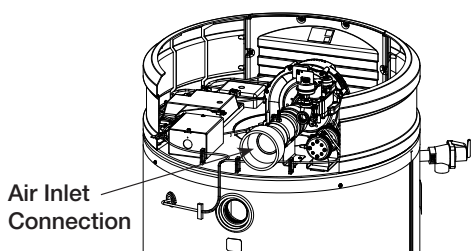


Figure 4. — Vent Pipe Connection Locations

## VENT PIPE CONNECTION —

**Note:** It is recommended that a suitable rubber coupling is used on the outlet vent connection.

Refer to Figure 4, for connecting the vent pipe to the water heater. These models can be vented either as a direct vent or as a power vent water heater.

**NOTICE:** If the unit is installed as a power vent water heater, the vent terminal with screen must still be installed on the inlet air side.

Before starting the vent installation, careful planning should be given to the routing and termination of the vent pipes. The length of the vent pipes (inlet and outlet) should be kept to a minimum. Also, see Figure 11 for vent terminal placement. Refer to the venting charts in Table 1 for the pipe sizes and the total equiv-

alent length of pipe that can be used. **DO NOT** exceed the equivalent length of pipe in the charts.

Depending on the size of pipe selected for venting the water heater, it may be necessary to use a fitting for stepping up or down in pipe size to connect to the water heater. All models are shipped with 3" vent terminals with screen. If another size of pipe is used for venting the unit, the proper vent terminal must be installed.

When the unit is vented as a direct vent, through a side wall, the vent terminals must be on the same exterior wall mounted horizontally and maintain a minimum distance between the centers of 24" (61 cm). See Figures 8, 9, and 11 for other vent terminal restrictions.

**JOINING PIPES AND FITTINGS —** All pipe, fittings, solvent cement, primers, and procedures, must conform to American National Standards Institute and American Society for Testing and Materials (ANSI/ASTM) standards in the U.S. For Canada, all pipe, fittings, solvent cement, primers, and procedures must conform to ULC-S636 and vent manufacture specifications.

**CEMENTING JOINTS —** All joints in the vent piping must be properly sealed. Use of the following material is recommended:

PVC materials should use ASTM D-2564 grade cement.

CPVC materials should use ASTM F-493 grade cement.

ABS materials should use ASTM D-2235 grade cement.

(ABS is not allowed in Canada)

**Cleaner-Primer and Medium Body Solvent Cement**

1. Cut the pipe end square, removing all jagged edges and burrs. Chamfer the end of the pipe, and, then, clean the fitting socket and pipe joint area to remove all dirt, grease, and moisture.
2. After checking pipe and socket for proper fit, wipe the socket and pipe with cleaner-primer. Apply a liberal coat of primer to the inside surface of the socket and the outside of the pipe. **DO NOT** allow the primer to dry before applying the cement.
3. Apply a thin coat of cement evenly in the socket. Quickly apply a heavy coat to the pipe end. Insert the pipe into the fitting with a slight twisting motion until it bottoms out.

**NOTICE: Cement must be fluid; if not, re-coat.**

4. Hold the pipe fitting for 30 seconds to prevent the tapered socket from pushing the pipe out of the fitting.
5. Wipe all excess cement from the joint with a rag. Allow 15 minutes for drying before handling. Cure time will vary according to fit, temperature, and humidity.

**NOTICE: Stir the solvent cement frequently while using. Use a natural bristle brush or the dauber supplied with the can. The proper brush size is one inch.**

FOR PROPER INSTALLATION:

## **CAUTION**

- **DO NOT** use solvent cement that has become curdled, lumpy or thickened.
- **DO NOT** thin solvent cement. Observe shelf precautions printed on the containers.

# Installation

- For applications below 32°F (0°C), use only low temperature type solvent cement.
- Appropriate solvent and cleaner must be used for the type of vent pipe used (PVC, CPVC, PP, or ABS).

**DANGER OF FIRE OR BODILY INJURY** – Solvent cements and primers are highly flammable. Provide adequate ventilation and do not assemble near a heat source or open flame. **DO NOT** smoke. Avoid skin or eye contact. Observe all cautions and warnings on material containers.

**DIRECT VENT INSTALLATION** - Check to make sure flue gases **DO NOT** recirculate into the air intake terminal when using direct venting. If the water heater is having service issues, flue recirculation may be a contributing factor. Even when the minimum vent terminal separation distances are followed, recirculation may still occur, depending upon the location outside the building, the distance from other buildings, proximity to corners, weather conditions, wind patterns, and snow depth. Periodically check to make sure that flue recirculation is not occurring. Signs of flue gas recirculation include frosted or frozen intake terminals, condensate in the intake terminal and venting system, oxidation, or white chalk material on the flame sensor or igniter shield. Correction to flue recirculation may involve angling the intake away from the exhaust terminal, increasing the distance between them, or using inside air for combustion. Check to be sure the intake and exhaust terminals are not obstructed, especially during periods of below freezing weather. All intake and exhaust venting components must have the same diameter size. **DO NOT** use a different size on the intake and exhaust venting.

Be sure the condensate runs freely to a drain and does not accumulate inside the water heater. In cold climates, precautions may need to be taken to insure that the condensate drain does not freeze. Make sure the condensate trap or drain loop is installed to prevent flue gases from being discharged into the room. Refer to the "Venting" section (page 8) of this manual for complete instructions on venting and condensate drainage.

Stress levels in the pipe and fittings can be significantly increased by improper installation. If rigid pipe clamps are used to hold the pipe in place, or if the pipe cannot move freely through a wall penetration, the pipe may be directly stressed, or high thermal stresses may be formed when the pipe heats up and expands. Install accordingly to minimize such stresses. Follow the below procedure to vent through the wall.

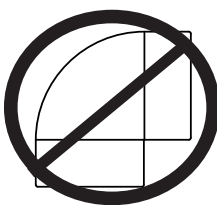
1. Cut two holes for the pipe to pass through. The hole diameter should be 2.5" (6.4 cm) for 2" pipe, 3.5" (8.9 cm) for 3" pipe, and 6.5" (16.5 cm) for 6" pipe. Vent terminals must maintain a horizontal distance apart in the range of 24" to 36" (61 cm to 91 cm). Refer to Figure 5 for additional information.
2. Use the proper PVC cement (primer and adhesive) to secure the exhaust vent and air intake terminals provided with the water heater to the plastic pipes. The distance between the back edge of the exhaust vent terminal and the exterior wall (see Figure 10) must be 6 inches (12.7 cm) more for the exhaust vent terminal than the air intake terminal. Use the proper cement or sealant and assembly procedures to secure the vent connector joints between the terminal and the blower outlet. Provide support brackets for every 3 feet (.91 m) of horizontal vent beyond the intake terminal as seen in Figure 10.

## Additional Fitting Considerations

Figure - 5. Examples of Elbows:

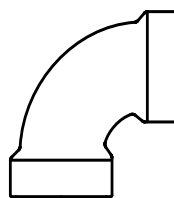
**DO NOT** use short sweep elbows. It is recommended to use only standard and/or long sweep elbows. See examples as shown.

DO NOT use



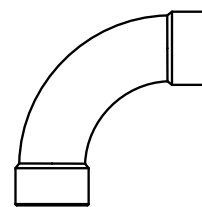
Short Sweep 90° Elbow

Good



Standard 90° Elbow

Best



Long Sweep 90° Elbow

# Installation

## MINIMUM AND MAXIMUM VENT LENGTHS

Important information for all installations:

- 1) The minimum required venting is what is required to safely extend the inlet and outlet vent pipes outside of the building.
- 2) Each 90° elbow (standard or long sweep elbow) reduces the equivalent vent length by 5 feet (1.5m).
- 3) Each 45° elbow reduces the equivalent vent length by 2 1/2 feet (0.8m).
- 4) **DO NOT** mix pipe sizes for venting these models, use only one size of pipe for all venting.
- 5) All vent terminations (horizontal or vertical) should be a minimum of 24 inches (61cm) and a maximum of 36 inches (91 cm) apart, as measured from center to center of terminals.
- 6) The maximum equivalent vent lengths, for inlet and outlet, must be within 20 equivalent feet (6.1m) of each other. Supplied vent terminal(s) are not included in the maximum equivalent vent length.

Feet	to	Meters
20		6.1
50		15.2
60		18.3
70		21.3
80		24.4
100		30.5
120		36.6
130		39.6
170		51.8

Exceeding the maximum equivalent vent lengths may cause the water heater to malfunction or cause a lock-out condition.

Power Vent		Max Vent Length (Eq.Ft.) Rigid Pipe Diameter							
		2" (5 cm)		3" (8 cm)		4" (10 cm)		6" (15 cm)	
		Inlet	Outlet	Inlet	Outlet	Inlet	Outlet	Inlet	Outlet
GHE80SU-130(A) or GHE80SU-160(A)	0-8999 Ft (0-2743 m)	1 (0.31 m)	35 (10.7 m)	1 (0.31 m)	135 (41.1 m)	1 (0.31 m)	185 (56.4 m)	N/A	N/A
GHE80SU-200(A)	0-8000 ft (0-2438 m)	1 (0.31 m)	35 (10.7 m)	1 (0.31 m)	135 (41.1 m)	1 (0.31 m)	185 (56.4 m)	N/A	N/A
GHE80SU-300(A)	0-8000 Ft (0-2438 m)	1 (0.31 m)	35 (10.7 m)	1 (0.31 m)	135 (41.1 m)	1 (0.31 m)	185 (56.4 m)	1 (0.31 m)	120 (36.6 m)
GHE100SU-130(A) or GHE100SU-160(A)	0-8999 ft (0-2743 m)	1 (0.31 m)	35 (10.7 m)	1 (0.31 m)	135 (41.1 m)	1 (0.31 m)	185 (56.4 m)	N/A	N/A
GH100SU-200(A)	0-8999 ft (0-2743 m)	1 (0.31 m)	35 (10.7 m)	1 (0.31 m)	135 (41.1 m)	1 (0.31 m)	185 (56.4 m)	N/A	N/A
GHE100SU-250(A) or GHE100SU-300(A)	0-8999 ft (0-2743 m)	1 (0.31 m)	35 (10.7 m)	1 (0.31 m)	135 (41.1 m)	1 (0.31 m)	185 (56.4 m)	1 (0.31 m)	120 (36.6 m)
GHE100SU-350(A) or GHE100SU-400(A)	0-8999 ft (0-2743 m)	N/A	N/A	1 (0.31 m)	65 (19.8 m)	1 (0.31 m)	100 (30.5 m)	1 (0.31 m)	135 (41.1 m)
		Min Vent Length (Eq.Ft.) Rigid Pipe Diameter							
All Models	See Below	1 (0.31 m)	15 (4.6 m)	1 (0.31 m)	15 (4.6 m)	1 (0.31 m)	15 (4.6 m)	1 (0.31 m)	15 (4.6 m)

**TABLE 1. POWER VENTING – RIGID VENT PIPING: PVC, CPVC, ABS, PP – MAX VENT LENGTHS**

Models GHE80SU-200(A) & GHE80SU-300(A) are limited to an altitude of 8000 ft, while all other models are limited to 8999 ft.

# Installation

Power Direct Vent		Max Vent Length (Eq.Ft.) Rigid Pipe Diameter							
Inlet Models	Altitude Range	2" (5 cm)		3" (8 cm)		4" (10 cm)		6" (15 cm)	
		Inlet	Outlet	Inlet	Outlet	Inlet	Outlet	Inlet	Outlet
GHE80SU-130(A) or GHE80SU-160(A)	0-2000 (0 - 609 m)	20 (6.1 m)	35 (10.7 m)	60 (18.3 m)	75 (22.9 m)	120 (36.6 m)	135 (41.1 m)	N/A	N/A
	2001-8999 (610 - 2743 m)	20 (6.1 m)	35 (10.7 m)	40 (12.2 m)	55 (16.8 m)	120 (36.6 m)	135 (41.1 m)	N/A	N/A
GH80SU-200(A) or GHE80SU-300(A)	0-8000 ft (0-2438 m)	20 (6.1 m)	35 (10.7 m)	60 (18.3 m)	75 (22.9 m)	120 (36.6 m)	135 (41.1 m)	120 (36.6 m)	135 (41.1 m)
GHE100SU-130(A) or GHE100SU-160(A)	0-2000 (0 - 609 m)	20 (6.1 m)	35 (10.7 m)	60 (18.3 m)	75 (22.9 m)	120 (36.6 m)	135 (41.1 m)	N/A	N/A
	2001-8999 (610 - 2743 m)	20 (6.1 m)	35 (10.7 m)	40 (12.2 m)	55 (16.8 m)	120 (36.6 m)	135 (41.1 m)	N/A	N/A
GH100SU-200(A) or GHE100SU-250(A) or GHE100SU-300(A)	0-2000 (0 - 609 m)	20 (6.1 m)	35 (10.7 m)	60 (18.3 m)	75 (22.9 m)	120 (36.6 m)	135 (41.1 m)	N/A	N/A
	2001-8999 (610 - 2743 m)	20 (6.1 m)	35 (10.7 m)	40 (12.2 m)	55 (16.8 m)	120 (36.6 m)	135 (41.1 m)	120 (36.6 m)	135 (41.1 m)
GHE100SU-350(A) or GHE100SU-400(A)	0-8999 ft (0 - 2743 m)	N/A	N/A	50 (15.2 m)	65 (19.8 m)	70 (21.4 m)	85 (25.9 m)	120 (36.6 m)	135 (41.1 m)
		Min Vent Length (Eq.Ft.) Rigid Pipe Diameter							
All Models	See Below	5 (1.5 m)	15 (15.2 m)	5 (1.5 m)	15 (15.2 m)	5 (1.5 m)	15 (15.2 m)	5 (1.5 m)	15 (15.2 m)

**TABLE 2. POWER DIRECT VENTING LENGTHS**

Models GHE80SU-200(A) & GHE80SU-300(A) are limited to an altitude of 8000 ft, while all other models are limited to 8999 ft.

For each 90° Elbow, reduce pipe length by five (5) feet.

For each 45° Elbow, reduce pipe length by two and a half (2.5) feet.

**Note: Vent pipe size should not be mixed for venting these units.**

**Use same diameter pipe for all venting of the unit.**

### Venting Configurations are the Same for SS Models:

All power direct vent models can use 3 in. or 4 in. concentric venting the above vent lengths.

3 inch concentric vent can only be used with 3 inch rigid piping.

4 inch concentric vent can only be used with 3 inch rigid piping.

**DO NOT mismatch concentric vent terminations with different rigid piping as it may cause the heater to malfunction or cause a lock-out condition.**

**DO NOT use 2 inch rigid venting with concentric vent terminations.**

**DO NOT use 6 inch rigid venting with concentric vent terminations.**

Flexible Polypropylene pipe (ft)				
Pipe Size (IN.)	3		4	
	Intake	Exhaust	Intake	Exhaust
Max PV	0	60	0	60

Models GHE80SU-200(A) & GHE80SU-300(A) are limited to an altitude of 8000 ft, while all other models are limited to 8999 ft.

# Installation

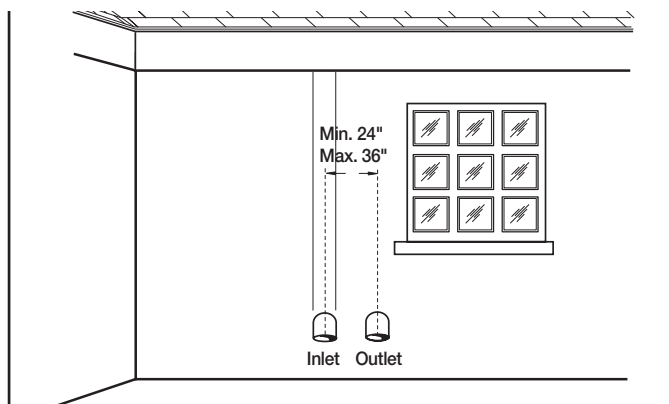


Figure 5

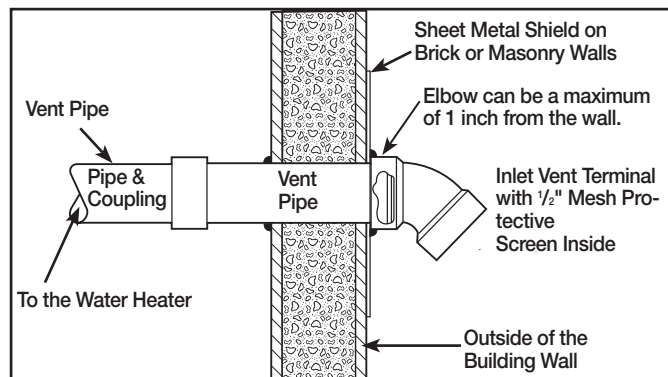


Figure 6 – Typical Horizontal Vent Installation

Additional Considerations (See Figures 10 & 11)

1. **DO NOT** install vent terminals under any patio or deck.
2. To help prevent moisture from freezing on walls and under eaves, **DO NOT** locate outlet vent terminal on the side of a building with prevailing winter winds.
3. **DO NOT** terminate vent pipe directly on brick or masonry surfaces. Use a rust-resistant sheet metal backing plate behind vent. (See Figure 6.)
4. **DO NOT** locate vent terminal too close to shrubbery, since flue gases may damage them.
5. Caulk all cracks, seams and joints within 6 feet (1.83 m) of vent terminal.
6. All painted surfaces should be primed to lessen the chance of physical damage. Painted surfaces will require maintenance.
7. Make sure that all vent pipes exposed to cold conditions (attics, crawl spaces, etc.) have the proper slope and support to keep moisture from accumulating in the vent pipes. **NOTE:** Insulating of non-metallic vent materials is prohibited.
8. This water heater requires its own separate venting system. **DO NOT** connect the exhaust vent to an existing vent pipe or chimney.

## **WARNING**

Moisture in the flue gas will condense as it leaves the vent terminal. In cold weather this condensate can freeze on the exterior wall, under the eaves, and on surrounding objects. Some discoloration to the exterior of the building is to be expected; however, improper location or installation can result in severe damage to the structure or exterior finish of the building. In locations with extended amounts of time with temperatures under 40°F. (4°C.) and/or prevailing wind toward the outlet vent, make sure that the outlet

vent terminal is at least 2 feet (0.61 m) away from anything that can be damaged by the condensate

**HORIZONTAL VENT INSTALLATION** – Once the vent terminal location has been determined, make a hole through the exterior wall to accommodate the vent pipe. The vent pipe must exit the exterior wall horizontally only (See Figure 6).

Insert a small length of vent pipe through the wall, and connect the coupling as shown in Figure 6. Connect the vent terminal as shown to the vent pipe on the exterior of the building. Seal any opening around the vent pipe or fittings with mortar or silicone caulk as shown in Figure 6.

Complete the rest of the vent pipe installation to the water heater's vent connector fitting on the blower outlet. If necessary, support the horizontal run of pipe as previously mentioned.

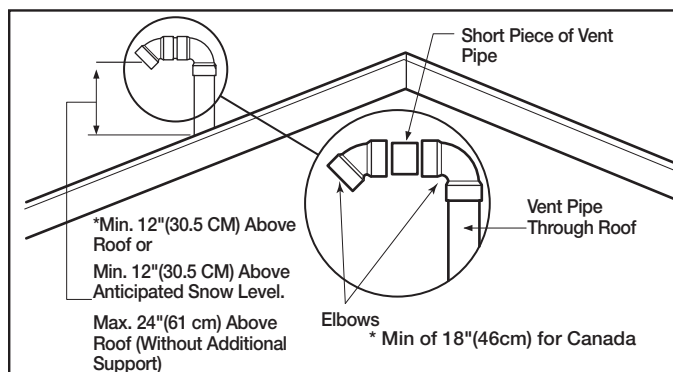


Figure 7 – Vertical Vent Terminal Location

**VERTICAL VENT INSTALLATION** – Once the vent terminal location has been determined, make a hole through the roof and interior ceiling to accommodate the vent pipe. Complete the vent pipe installation to the water heater's vent connector fitting on the blower outlet. Support vertical or horizontal runs as previously mentioned.

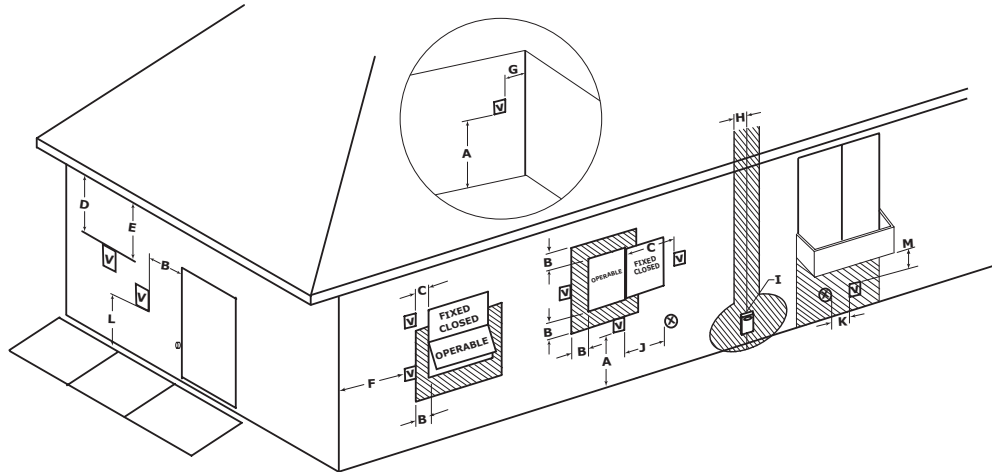
Install adequate flashing where the vent pipe passes through the roof. Determine the vent terminal height and cut the vent pipe accordingly. Refer to Figure 9 for the proper vent terminal height. Connect the vent elbow onto the vertical pipe through the roof. Connect a short piece of vent pipe (approximately 3" (7.6 cm) long) to the elbow, and, then, join the vent terminal to the short piece of vent pipe.

**VERTICAL VENT TERMINAL LOCATION** – The location of the vertical vent terminal depends on the following considerations (see Figure 7):

1. Minimum 12" (30.5 cm) above the roof 18" (46 cm) for Canada.
2. Minimum 12" (30.5 cm) inches above anticipated snow level.
3. Maximum 24" (61 cm) above roof level without additional support for vent pipe.
4. 4 feet (1.22 m) from any gable, dormer or other roof structure with building interior access (i.e., vent, window, etc.).
5. 10 feet (3.05 m) from any forced air inlet to the building. Any fresh or make-up air inlet such as a dryer or furnace area is considered to be a forced air inlet.
6. Vent terminals are a minimum of 24" (61 cm) and a maximum of 36" horizontally apart.

# Installation

Figure 8



☑ VENT TERMINAL    ⊗ AIR SUPPLY INLET    ▨ AREA WHERE TERMINAL IS NOT PERMITTED

## Horizontal Vent Terminal Location for Power Direct Vent

The following information should be used for determining the proper location of the vent terminal for direct vent water heaters.

	Canadian Installations <sup>1</sup>	US Installations <sup>2</sup>
A= Clearance above grade, veranda, porch, deck or balcony.	12 inches (30 cm)	12 inches (30 cm)
B= Clearance to window or door that may be opened.	6 inches (15 cm) for appliances ≤ 10,000 Btuh (3 kW), 12 inches (30 cm) for appliances > 10,000 Btuh (3kW) and ≤ 100,000 Btuh (30kW), 36 inches (91 cm) for appliances > 100,000 Btuh (30kW).	6 inches (15 cm) for appliances ≤ 10,000 Btuh (3 kW), 9 inches (23 cm) for appliances > 10,000 Btuh (3 kW) and ≤ 50,000 Btuh (15 kW), 12 inches (30 cm) for appliances > 50,000 Btuh (15 kW)
C= Clearance to permanently closed window.	*	*
D= Vertical Clearance to ventilated soffit located above the terminal within a horizontal distance of 2 feet (61 cm) from the center line of the terminal.	*	*
E= Clearance to unventilated soffit.	*	*
F= Clearance to outside corner.	*	*
G= Clearance to inside corner.	*	*
H = Clearance to each side of center line extended meter/regulator assembly above	3 feet (91 cm) within a height 15 feet (4.57 m) above the meter/regulator assembly.	*
I = Clearance to service regulator vent outlet.	3 feet (91 cm)	*
J = Clearance to nonmechanical air supply inlet to the building or the combustion air inlet of any other appliance..	6 inches (15 cm) for appliances ≤ 10,000 Btuh (3 kW), 12 inches (30 cm) for appliances > 10,000 Btuh (3kW) and ≤ 100,000 Btuh (30kW), 36 inches (91 cm) for appliances > 100,000 Btuh (30kW).	6 inches (15 cm) for appliances ≤ 10,000 Btuh (3 kW), 9 inches (23 cm) for appliances > 10,000 Btuh (3 kW) and ≤ 50,000 Btuh (15 kW), 12 inches (30 cm) for appliances > 50,000 Btuh (15 kW)
K = Clearance to mechanical air supply inlet.	6 feet (1.83 m)	3 feet (91 cm) above if within 10 feet(3 m) horizontally.
L = Clearance above paved side walk or paved driveway located on public property.	7 feet (2.13 m)+	7 feet (2.13 m)+
M = Clearance under veranda, porch, deck or balcony.	Not Allowed	Not Allowed

<sup>1</sup> In accordance with current CAN/CSA-B149.1 Installation Codes.

<sup>2</sup> In accordance with current ANSI Z223.1/ NFPA 54 National Fuel Gas Code.

+ A vent shall not terminate directly above a sidewalk or paved driveway that is located between two single family dwellings and serves both dwellings.

\*"Clearance in accordance with local installation codes and the requirements of the gas supplier."

# Installation

- **DO NOT** terminate near soffit vents or crawl space or other area where condensate or vapor could create a nuisance hazard or cause property damage.
- **DO NOT** locate the exhaust vent terminal where condensate or vapor could cause damage or could be detrimental to the operation of regulators, relief valves, or other equipment.
- **DO NOT** locate the exhaust vent terminal over public area or walkways where condensate or vapor can cause nuisance or hazard.
- **DO NOT** locate the vent terminal in proximity to plants/shrubs.

VENT INSTALLATION – Before proceeding, make certain you understand the procedure and cautions covered in the section “Joining Pipes and Fittings.”

## POWER VENT INSTALLATION:

Power venting is where the indoor air is used and the exhaust is vented to the outside. Venting may be run horizontally through an outside wall or vertically through a roof through using either 2" (5.1 cm), 3" (7.6 cm), 4" (10.2 cm) or 6" (15.2 cm) diameter PVC, ABS or CPVC. This water heater is supplied with a screened intake elbow and exhaust coupling referred to as the air intake terminal and the exhaust vent terminal.

## NOTE:

Flexible PP vent kit is available for Power Vent configurations, in either 3" or 4" diameters. These kits should be used for vertical venting only.

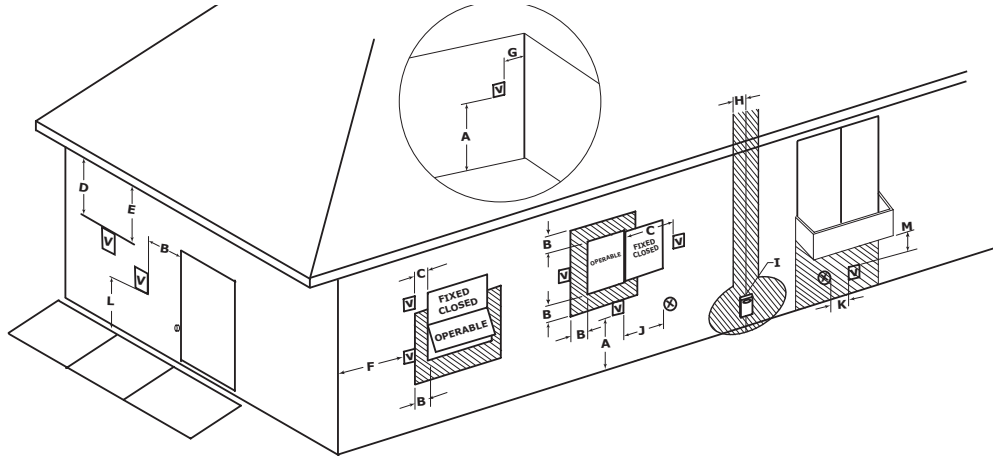
**NOTICE:** Use of PVC cellular core (ASTM-F891), ABS Schedule 40, DWV cellular core (ASTM –F628), or Radel® (polyphenylsulfone) in non-metallic venting systems is prohibited.

In a horizontal application, it is important that condensate not be allowed to buildup in the exhaust vent pipe. To prevent this from happening, the pipe should be installed with a slight upward slope of ¼" per foot. The vent system must be supported every 5 feet of vertical run and every 3 feet of horizontal run of vent pipe length.

Failure to properly support the vent piping with hangers and clamps may result in damage to the water heater or venting system.

# Installation

Figure 9



V VENT TERMINAL   
 X AIR SUPPLY INLET   
  AREA WHERE TERMINAL IS NOT PERMITTED

## Horizontal Vent Terminal Location for Power Vent

The following information should be used for determining the proper location of the vent terminal for direct vent water heaters.

	Canadian Installations <sup>1</sup>	US Installations <sup>2</sup>
A= Clearance above grade, veranda, porch, deck or balcony.	12 inches (30 cm)	12 inches (30 cm)
B= Clearance to window or door that may be opened.	6 inches (15 cm) for appliances ≤ 10,000 Btuh (3 kW), 12 inches (30 cm) for appliances > 10,000 Btuh (3kW) and ≤ 100,000 Btuh (30kW), 36 inches (91 cm) for appliances > 100,000 Btuh (30kW).	4 feet (1.2 m) below or to side of opening; 1 foot (300 mm) above opening.
C= Clearance to permanently closed window.	*	*
D= Vertical Clearance to ventilated soffit located above the terminal within a horizontal distance of 2 feet (61 cm) from the center line of the terminal.	*	*
E= Clearance to unventilated soffit.	*	*
F= Clearance to outside corner.	*	*
G= Clearance to inside corner.	*	*
H = Clearance to each side of center line extended meter/regulator assembly above	3 feet (91 cm) within a height 15 feet (4.57 m) above the meter/regulator assembly.	*
I = Clearance to service regulator vent outlet.	3 feet (91 cm)	*
J = Clearance to nonmechanical air supply inlet to building or the combustion air inlet to any other appliance..	6 inches (15 cm) for appliances ≤ 10,000 Btuh (3 kW), 12 inches (30 cm) for appliances > 10,000 Btuh (3kW) and ≤ 100,000 Btuh (30kW), 36 inches (91 cm) for appliances > 100,000 Btuh (30kW).	4 feet (1.2 m) below or to side of opening; 1 foot (300 mm) above opening.
K = Clearance to mechanical air supply inlet.	6 feet (1.83 m)	3 feet (91 cm) above if within 10 feet (3 m) horizontally.
L = Clearance above paved side walk or paved driveway located on public property.	7 feet (2.13 m)+	7 feet (2.13 m)+
M = Clearance under veranda, porch, deck or balcony.	Not Allowed	Not Allowed

<sup>1</sup> In accordance with current CAN/CSA-B149.1 Installation Codes.

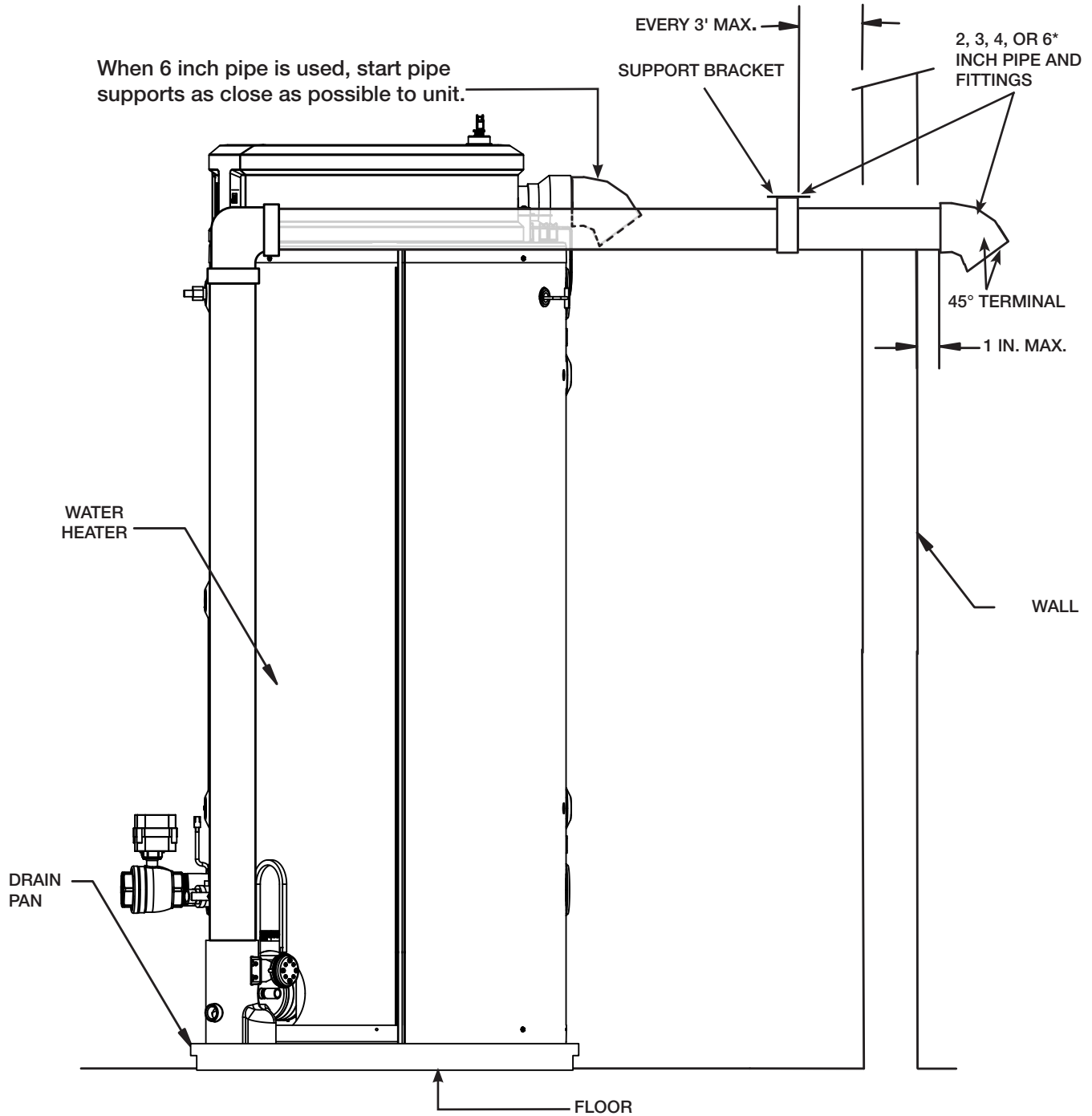
<sup>2</sup> In accordance with current ANSI Z223.1/ NFPA 54 National Fuel Gas Code.

+ A vent shall not terminate directly above a sidewalk or paved driveway that is located between two single family dwellings and serves both dwellings.

\* "Clearance in accordance with local installation codes and the requirements of the gas supplier."

# Installation

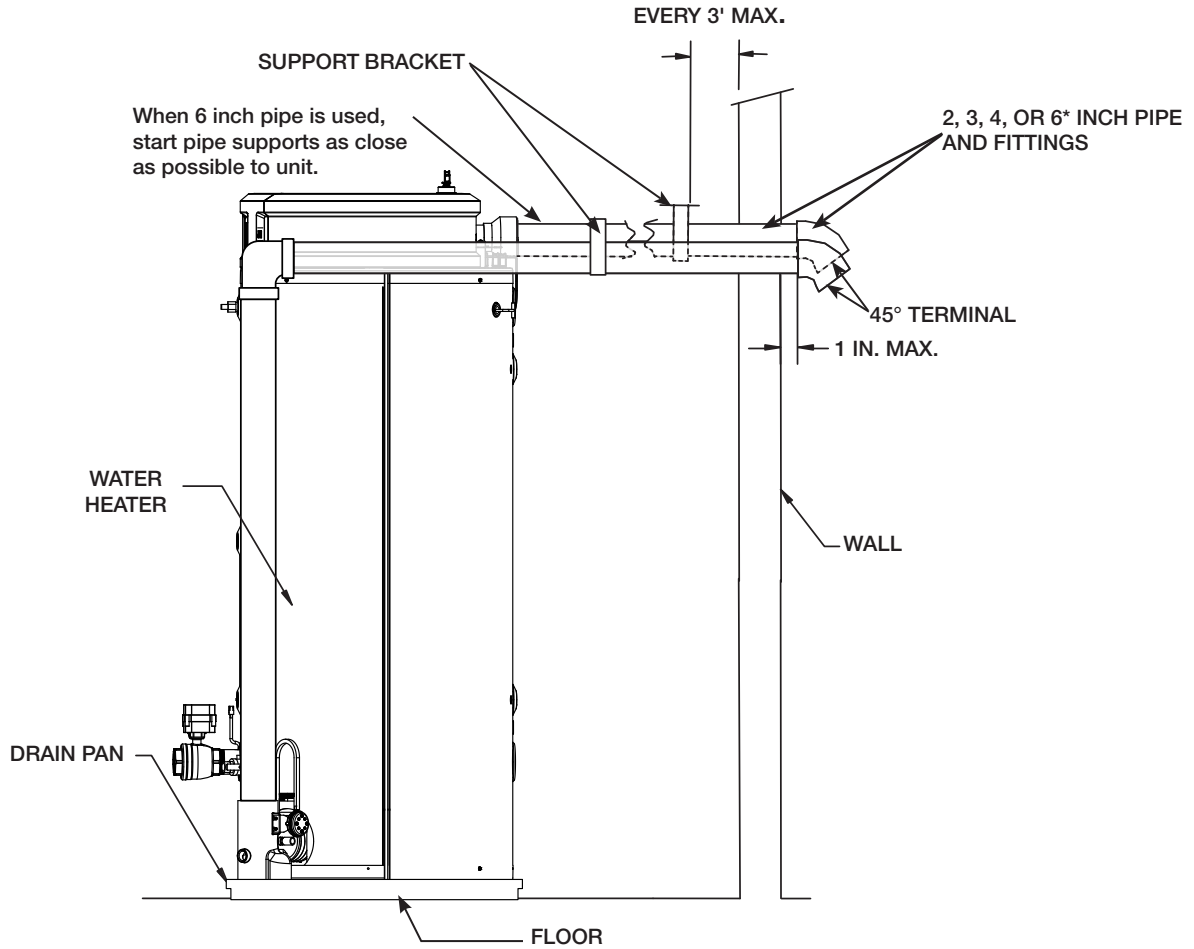
Figure - 10- Typical Horizontal Power Vent System



\* A 6 inch pipe can be used on 300,000 Btu/h models and above.

# Installation

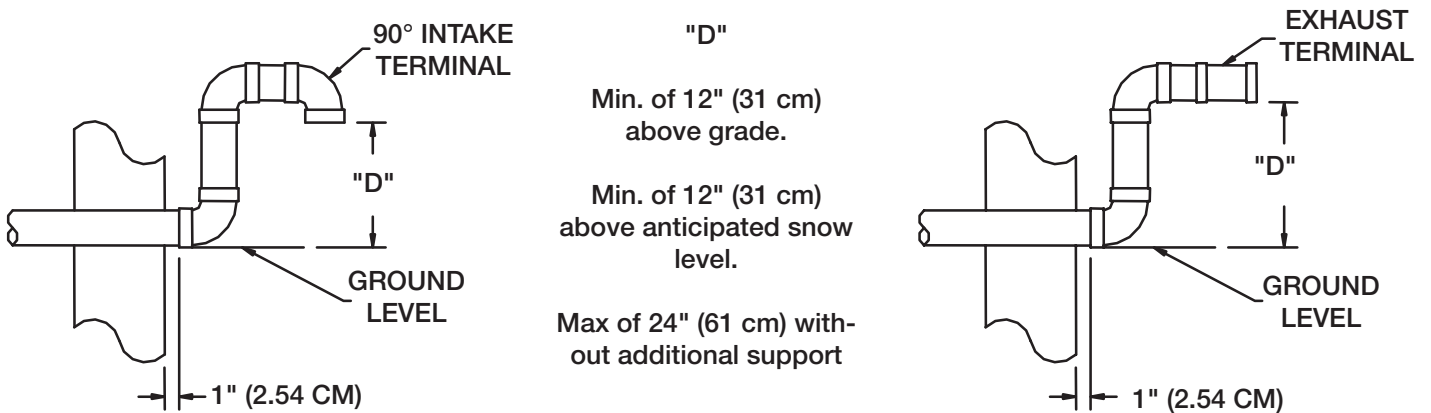
**Figure - 11- Typical Horizontal Direct Vent System**



\* A 6 inch pipe can be used on 300,000 Btu/h models and above.

**Through The Wall Venting With Low Ground Clearance:**

When venting cannot exit through the wall at a height greater than or equal to 12" (30.5 cm) (and above expected snow level) from the ground, then the installation must be modified as shown below (see Figure 11a).

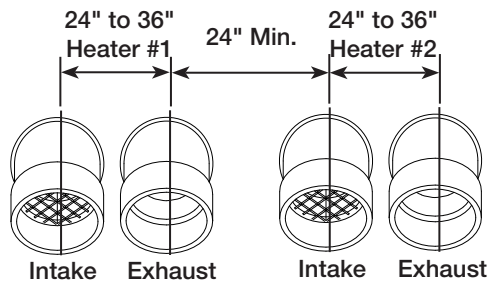


**Figure 11a. Vent Terminal (Low Ground Clearance)**

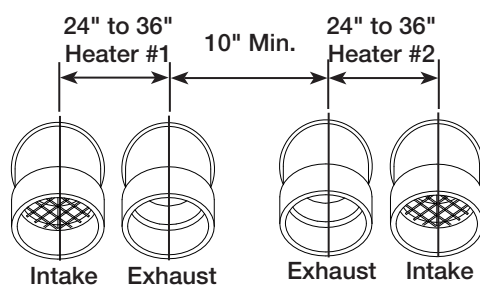
# Installation

## Horizontal Venting

**Figure 12a: Multiple Unit Venting**



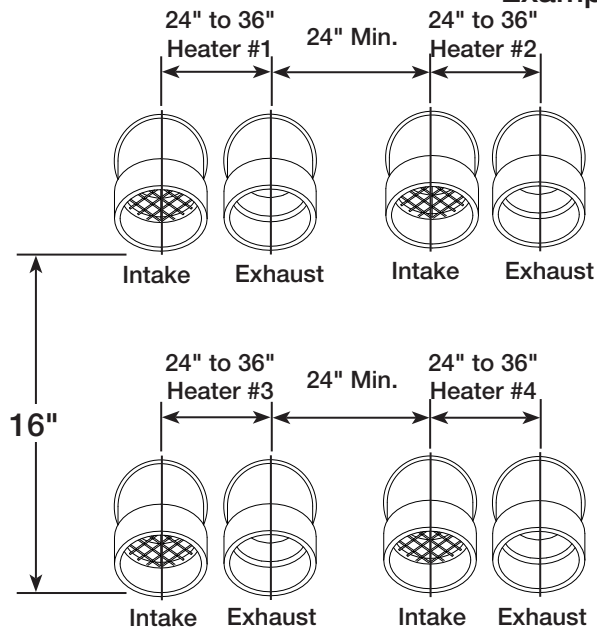
**Figure 12c: Optional Configuration**



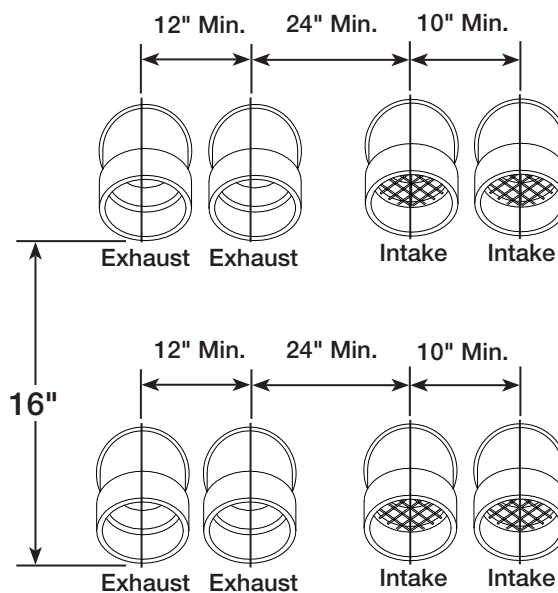
**Figure 12b: Multiple Unit Venting**

NOTICE: 11c can also be configured for 4 units.

Example of 4 Units' Vent.

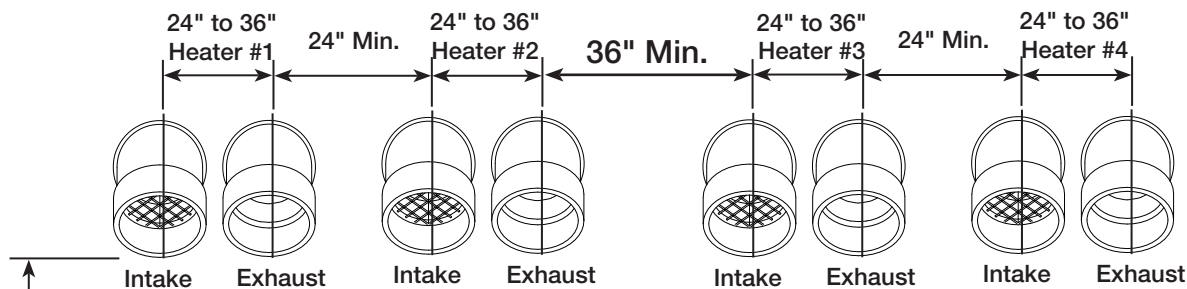


**Figure 11d: Optional Configuration**



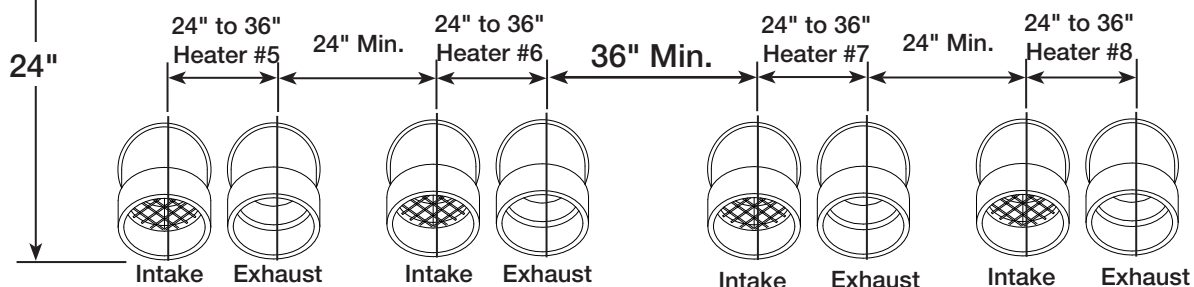
**Figure 12e**

Example of 4 Units' Vent.



**Figure 12f**

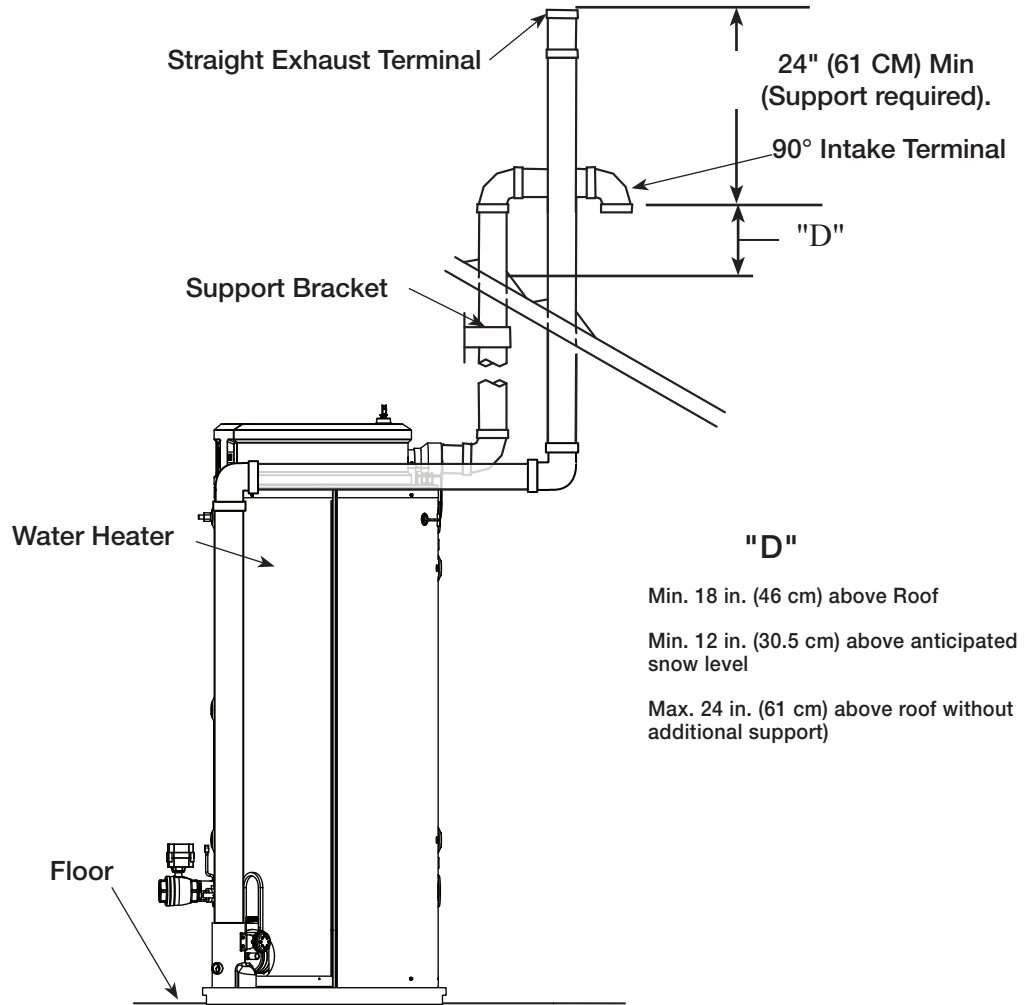
Example of 8 Units' Vent.



inch to cm	
10"	= 25 cm
12"	= 31 cm
16"	= 41 cm
18"	= 46 cm
24"	= 61 cm
36"	= 91 cm

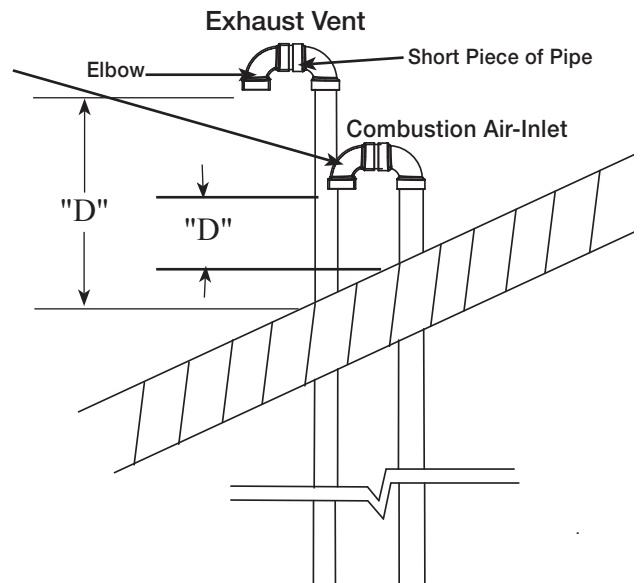
# Installation

Figure 13. Typical Vertical Direct Vent System Installation

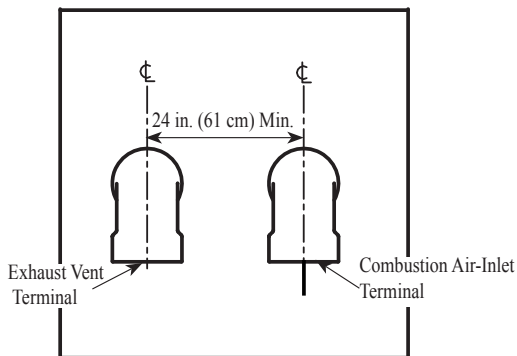


Alternate vertical venting with exhaust vent turned down - preferred for cold climates.

Terminals with 1/2 in. (1.3 cm) Mesh Protective Screen

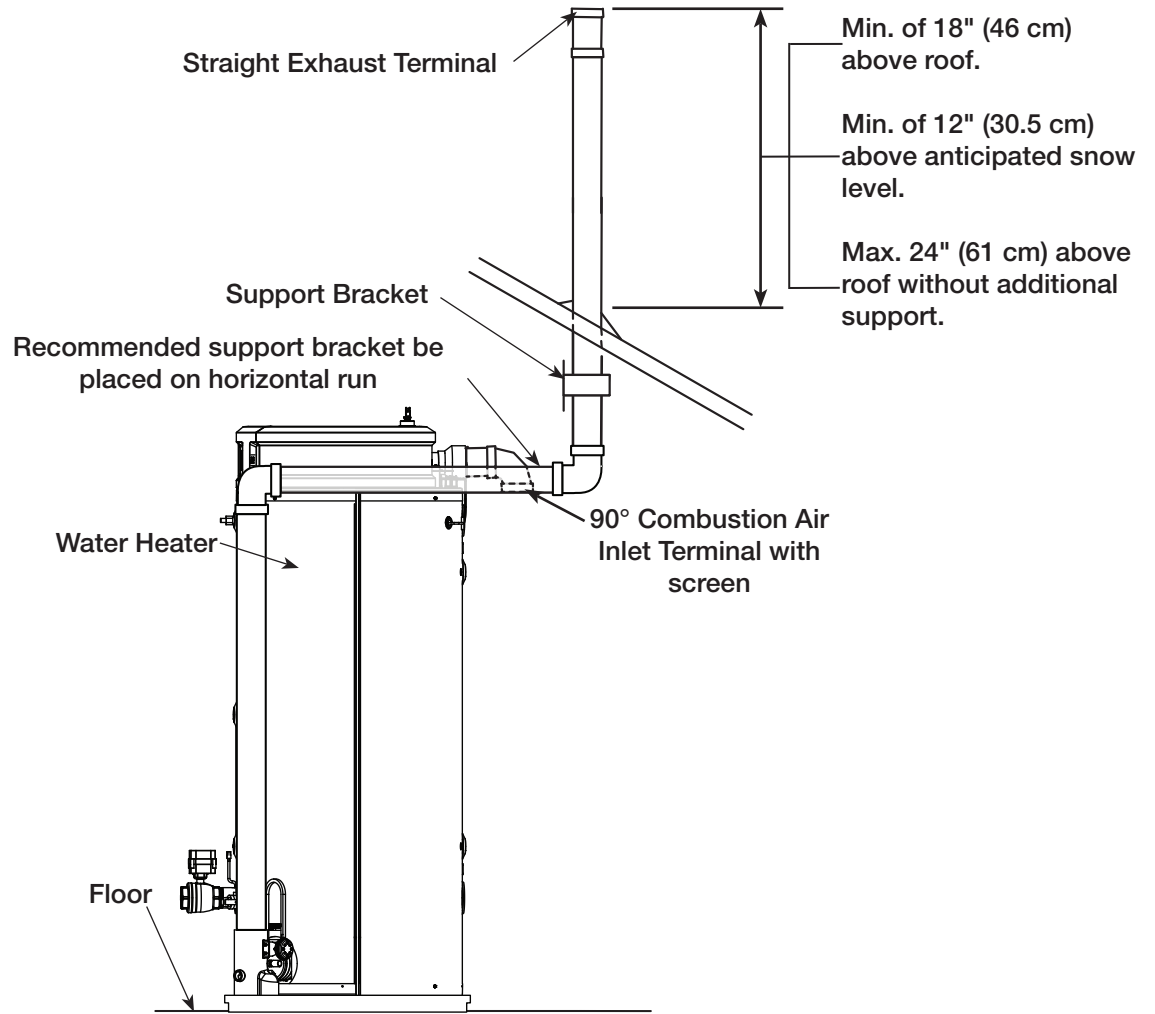


Terminals spacing for horizontal or vertical venting.

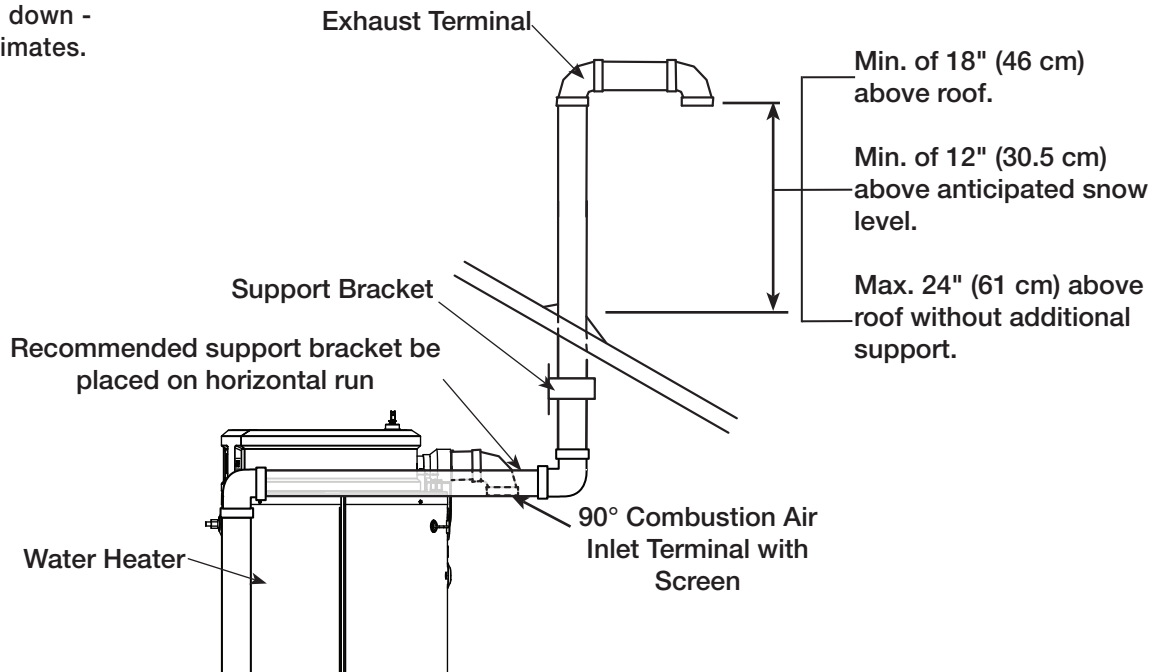


# Installation

Figure 14. Typical Vertical Power Vent System Installation

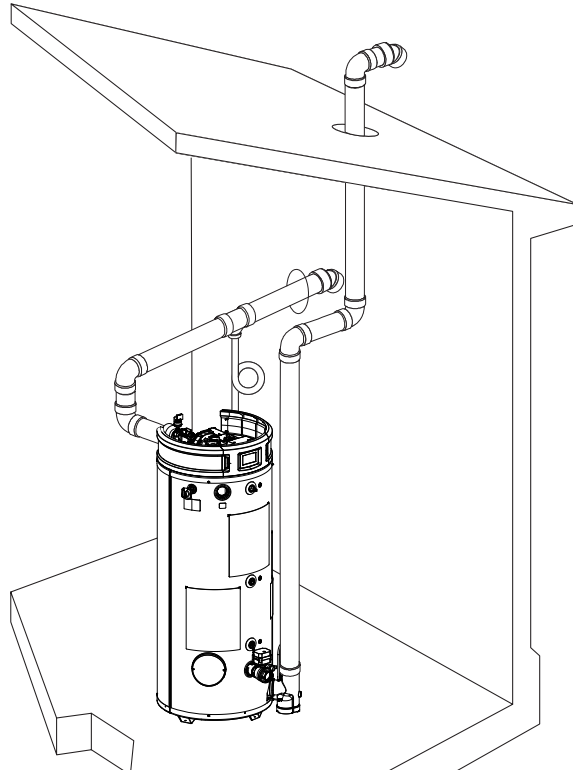


Alternate vertical venting with exhaust vent turned down - preferred for cold climates.

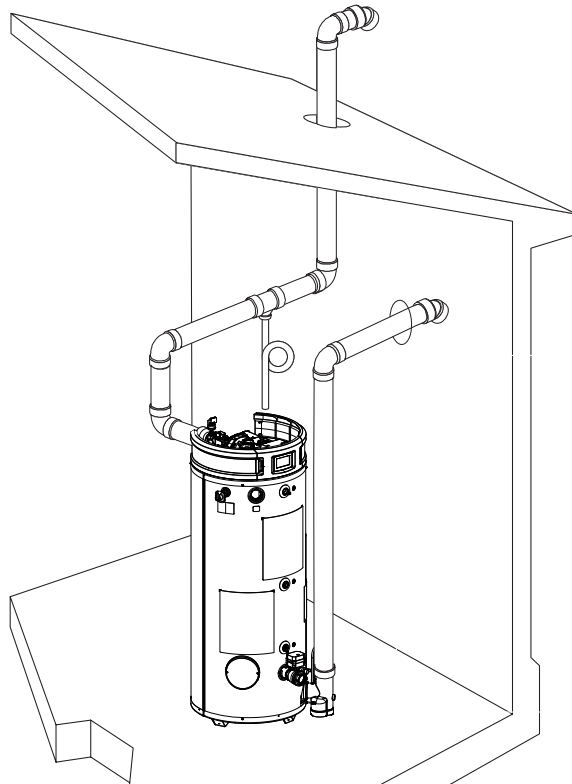


# Installation

Figure 15. Direct Vent Vertical Vent Horizontal Intake



Direct Vent Horizontal Vent Vertical Intake



# Installation

## CONCENTRIC VENT TERMINAL INSTALLATION: PROCEDURE

Improper installation, adjustment, service, or maintenance can cause property damage, personal injury, or death. Consult a qualified installer, service agency, or gas supplier for information or assistance.

This kit must be used only for terminating this water heater. **DO NOT** use this termination kit for any other appliance. Using this kit on other appliances and/or water heaters can result in property damage, personal injury, or death.

**NOTICE:** Concentric vent kit requires that the joints be cemented.

## CAUTION

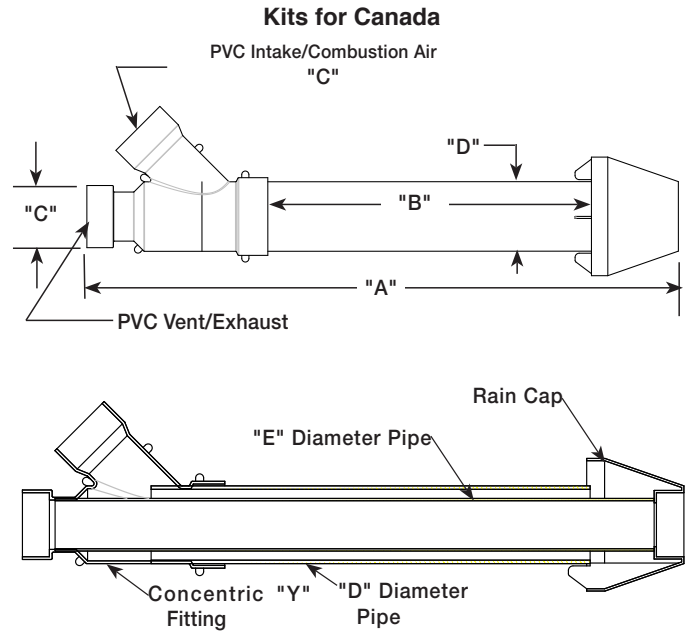
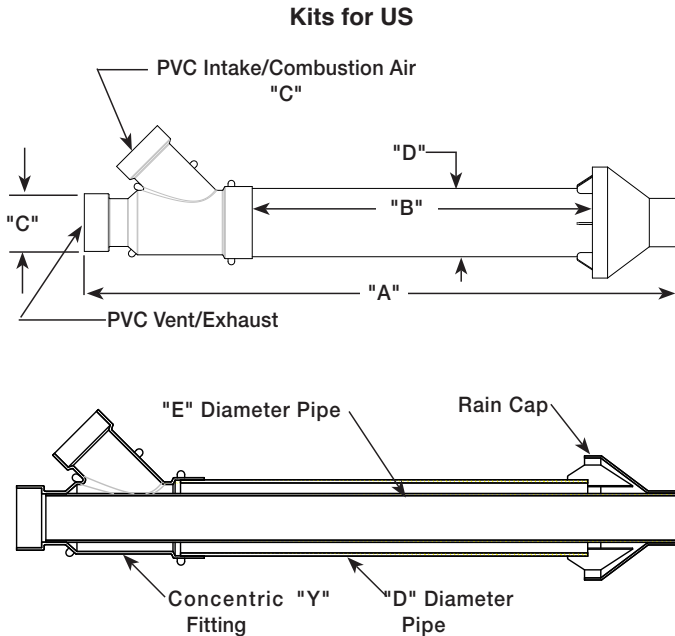
**DO NOT** operate this water heater with the rain cap removed or recirculation of combustion products may occur. Water may also collect inside larger combustion-air pipe and flow to the burner assembly. Failure to follow this warning could result in product damage, improper operation, personal injury or death.

**DO NOT** use field-supplied couplings to extend pipes. Airflow restriction will occur and the water heater pressure switches may cause intermittent problems.

Kits for US					Kits for Canada (ULC S636 Material)						
	Nominal PVC Dimensions					Nominal PVC Dimensions					
	"A"	"B"	"C"	"D"	"E"		"A"	"B"	"C"	"D"	"E"
3" Vent Kit	39.98"	21"	3"	4" *	2"	3" Vent Kit	36.16" (91.9 cm)	21" (53.3 cm)	3" (7.6 cm)	4" * (10.2 cm)	2" (5.1 cm)
4" Vent Kit	53.75"	34.8"	4"	6" ^	4"	4" Vent Kit	55.96" (142 cm)	38.25" (97.2 cm)	4" (10.2 cm)	6" * (15.2 cm)	4" (10.2 cm)

\*Hole size for nominal 4" PVC would be 5" (12.7 cm) and for 6" PVC would be 7" (17.8 cm).

^ The pipe is on 6.3" OD, but a 7" hole can still be used.



## Installation:

1. Become familiar with concentric vent kit parts (see charts above).
2. Determine the best location for the termination kit.
3. Cut the recommended diameter hole for the nominal PVC pipe size called out in the charts above – Dim. "D".
4. Partially assemble the vent kit by performing the following:
  - a. Cement concentric Y fitting to larger diameter pipe (see charts above).
  - b. Cement rain cap to smaller diameter pipe (see charts above).

# Installation

## ⚠ WARNING

These instructions are intended as an aid to qualified service personnel for proper installation, adjustment, and operation of this kit. Read these instructions thoroughly before attempting installation, adjustment, or operation. Failure to follow these instructions can result in improper installation, adjustment, service, or maintenance possibly resulting in fire, electrical shock, property damage, personal injury, or death.

## ⚠ WARNING

This kit is to be used only for vent & combustion air-inlet termination for power direct vent gas water heaters. **DO NOT** use this kit to terminate any other type of appliance. Failure to follow this warning could result in fire, personal injury, or death.

**LOCATION:** The Concentric Vent & Combustion Air-Inlet Termination Kit can be installed in a horizontal or vertical (roof) orientation. Before installation procedures begin, determine the best location for the termination kit.

**IMPORTANT:** When installing the kit, consider the following when choosing a location:

- Kit is positioned where vent gases will not damage nearby structure.
- Kit is positioned so that wind will not cause combustion products, leaves, snow, or other debris to enter the combustion air-inlet.
- Kit is positioned where it will not get damaged by foreign objects (i.e.: balls, stones, etc.).
- Kit is positioned where vent gases will not be inhaled or cause a nuisance.

**NOTE:** Ensure that the heights of the vent and/or combustion air-inlet openings are at least 12" above the anticipated snow level.

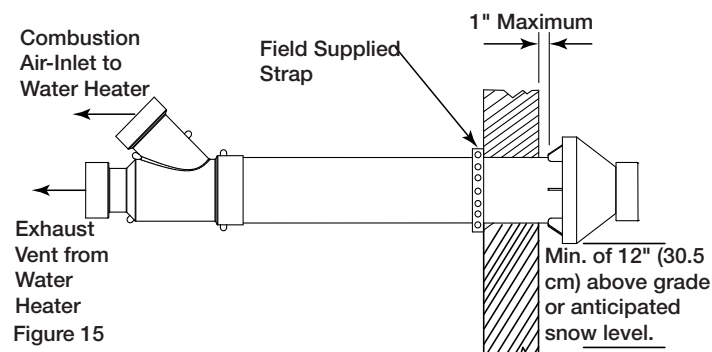
## HORIZONTAL INSTALLATION

### STEP 1:

Cut the proper size opening (see "D" in chart) in the sidewall and install the field supplied weather-seal boot/flashing for PVC pipe.

### STEP 2:

From inside, insert the combustion air-inlet pipe through the seal boot so that a maximum of 1" clearance occurs between the outside wall and the rain cap fins (See Figure 16). Ensure that no insulation or debris accumulate in the pipe.



### STEP 3:

Secure the combustion air-inlet pipe using a field supplied perforated strap or a suitable type material (see Figure 16).

### STEP 4:

Assemble the vent pipe assembly by cleaning and cementing the rain cap to the smaller diameter vent pipe.

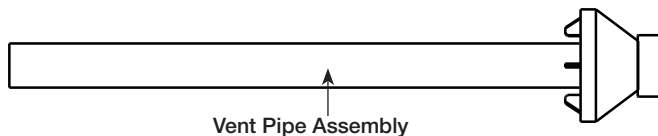


Figure 17

**Note:** If field disassembly is desired for cleaning, a stainless steel screw may be used to secure the rain cap to the PVC vent pipe.

## ⚠ WARNING

When using the alternate screw method, pre-drill a clearance hole in the rain cap slightly larger than the screw and a pilot hole in the vent pipe to prevent cracking of the PVC pipe. Cracking of the PVC components will cause a failure of the system, allowing combustion products to be recirculated. Failure to follow this warning could result in personal injury of death.

## ⚠ WARNING

**DO NOT** operate the water heater with the rain cap and elbow removed or recirculation of combustion products may occur. The vent and combustion air-inlet systems may also take in water, causing damage to the water heater. Failure to follow this warning could result in damage to the unit, improper operation, personal injury, or death.

### STEP 5:

From the outside, slide the vent pipe assembly through the combustion air-inlet pipe and cement the rain cap to the combustion air-inlet pipe. From the inside, cement the "Y" fitting to the combustion air-inlet pipe (see Figure 16 & 17).

### STEP 6:

Complete the installation of the remainder of the vent and combustion air-inlet systems as required in this manual.

## VERTICAL INSTALLATION

### STEP 1:

Cut a proper size opening (see "D" in chart) in the roof, and install field-supplied weather-seal boot/flashing for the larger PVC pipe.

### STEP 2:

From inside, insert the larger diameter combustion air-inlet pipe up through the seal boot, ensuring that no insulation or debris accumulate in the pipe. Ensure termination height is above the 12" minimum clearance anticipated snow level.

# Installation

## STEP 3:

Secure the combustion air-inlet pipe using a field supplied perforated strap or a suitable type material. (see Figure 18).

## STEP 4:

Assemble the vent pipe assembly by cleaning and cementing the rain cap to the smaller diameter exhaust pipe. Assemble the 90° elbow by cleaning and cementing it to the rain cap. Assemble the field supplied PVC connector and 90° elbow by cleaning and cementing them together as shown in Figure 18. The alternate screw method is not necessary for the field supplied PVC parts.

Note: If field disassembly is desired for cleaning, a stainless steel screw may be used to secure the rain cap to the smaller diameter exhaust pipe.

## WARNING

When using the alternate screw method, pre-drill a clearance hole in the rain cap slightly larger than the screw and a pilot hole in the vent pipe to prevent cracking of the PVC pipe. In a separate location, pre-drill a slightly larger clearance hole in the 90° elbow and a pilot hole in the rain cap for the screw being used at that site. Cracking of the PVC components will cause a failure of the system, allowing combustion products to be recirculated. Failure to follow this warning could result in personal injury or death.

## WARNING

DO NOT operate the water heater with the rain cap removed or recirculation of combustion products may occur. The vent air pipes may also take in water, causing damage to the water heater. Failure to follow this warning could result in damage to the unit, improper operation, personal injury, or death.

## STEP 5:

From the roof top, slide the vent pipe assembly down through the intake pipe and cement the rain cap to the intake pipe. From the inside, cement the "y" fitting to the intake pipe (See Figure 18).

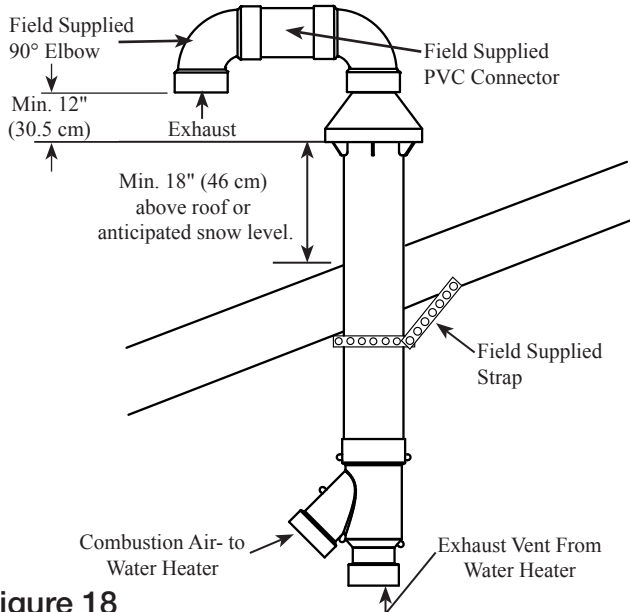


Figure 18

Figure 19 Multiple Sidewall or Vertical Concentric Vents

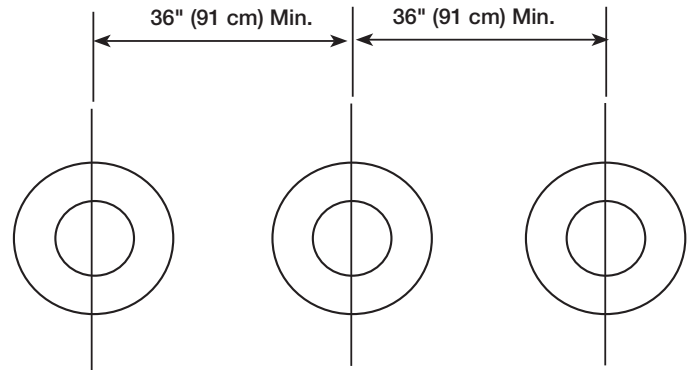
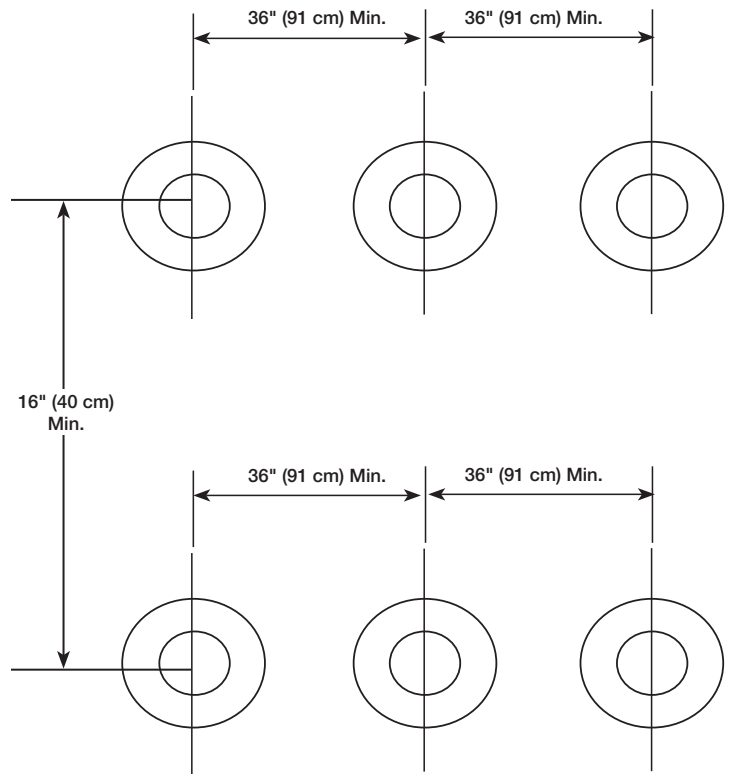


Figure 19A Multiple Sidewall Concentric Vents



## STEP 6:

Complete the installation of the remainder of the vent and air intake systems as required in this manual.

# Installation

The GHE80SS/SU and GHE100SS/SU models have been certified to use polypropylene pipe for both the intake and exhaust vent systems, but must use the current PVC vent terminations (including concentric vents). All polypropylene pipe and fittings listed in the tables below are ULC-S636 listed.

PP Chart 1 **Centrotherm**

Nominal Pipe Diameter	PVC to PP Adapter	Connector Ring**	45 Degree Elbow	87 Degree Elbow	Vent Material	Terminals
2"	ISAGL0202	IANS02**	SELL0245	ISELL0287	ISVL02-1,2,3,6	USE CURRENT PVC TERMINALS
3"	ISAGL0303	IANS03**	SELL0345	ISELL0387	ISVL03-1,2,3,6	
4"	ISAGL0404	IANS04**	ISEL0445	ISELL0487	ISVL04-1,2,3,6	

**M&G**

PP Chart 2 **Duravent**

Nominal Pipe Diameter	PVC to PP Adapter	Locking Band	45 Degree Elbow	90 Degree Elbow	Vent Material	Terminals
2"	2PPS-ADL	2PPS-LB2	2PPS-E45L*	2PPS-E90L*	2PPS-12L,36L,72L*	USE CURRENT PVC TERMINALS
3"	3PPS-ADL	3PPS-LB2	3PPS-E45L*	3PPS-E90L*	3PPS-12L,36L,72L*	
4"	4PPS-ADL	4PPS-LB2	4PPS-E45L*	4PPS-E90L*	4PPS-12L,36L,72L*	

**\*Can also be BL instead of L. A lock ring should be used at every pipe/fitting connection.**

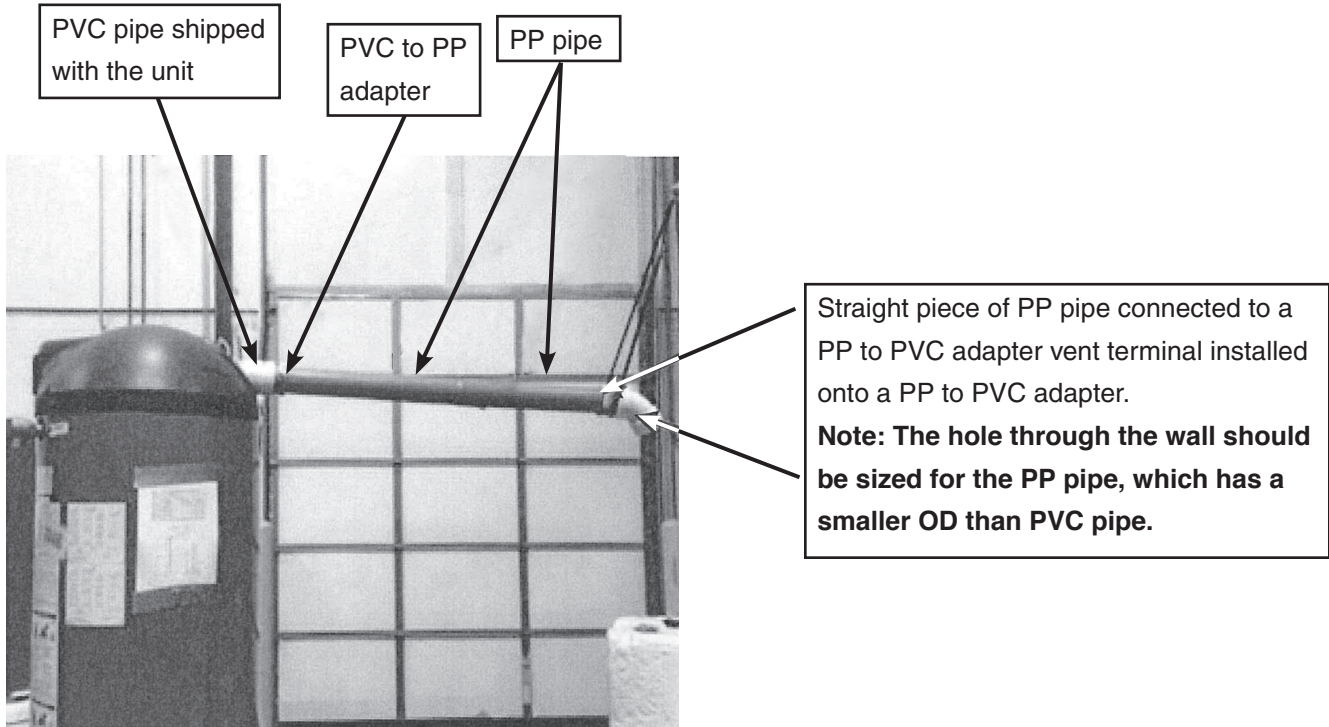
**\*\*Connector rings should be used for all pipe/fitting connections.**

The GHE80SS/SU and 100SS/SU models can be vented using rigid polypropylene pipe, to the same vent lengths called out in the current GHE manuals (AP14729-5 and AP18494). The overall vent length (pipe and elbows) must fall within the allowable vent terminal configurations shown in the manuals. An adapter (see charts above) will be needed to join the polypropylene pipe to the PVC pipe shipped with the units.

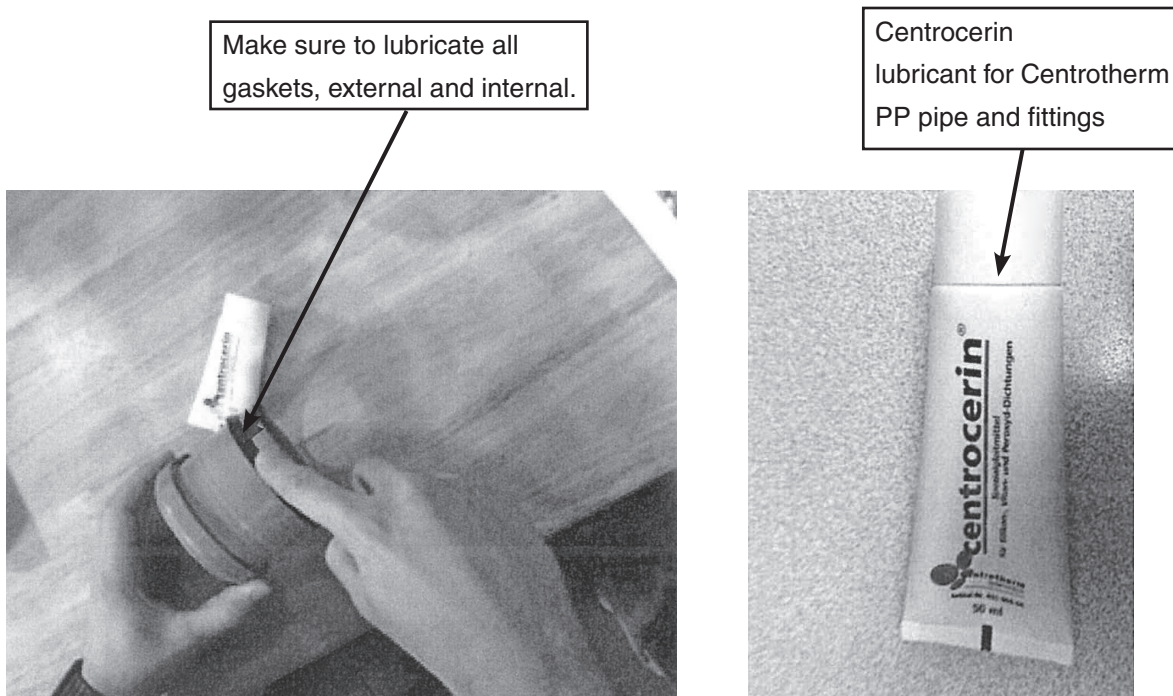
At the vent terminations, the polypropylene pipe will need to convert back to one of the allowable PVC termination configurations currently used.

Page 28 shows what a complete vent set up would consist of for either the intake or exhaust vent system.

# Installation



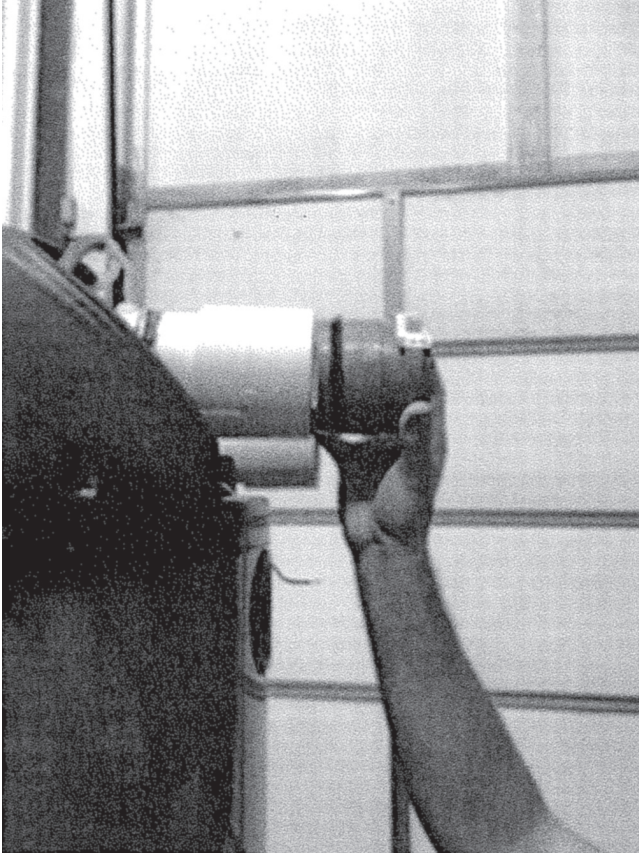
The first step to install the PP pipe is to find a PVC to PP adapter and lubricate the gasket that will slide into the PVC fitting. The lubricant for the Centrotherm parts is called Centrocerin. Apply a small amount onto your finger and then apply to the outer gasket.



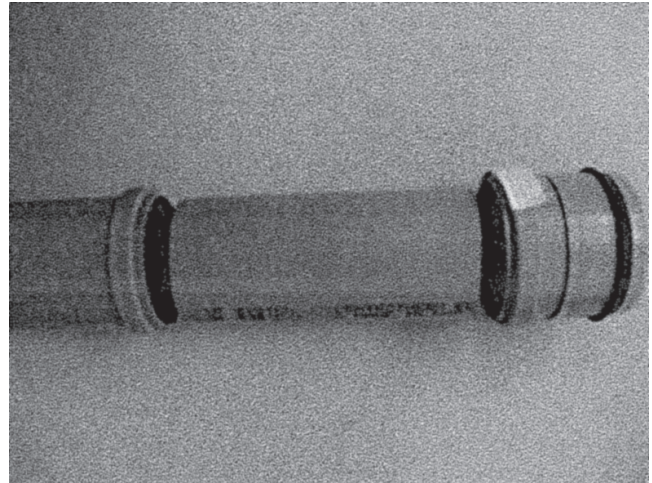
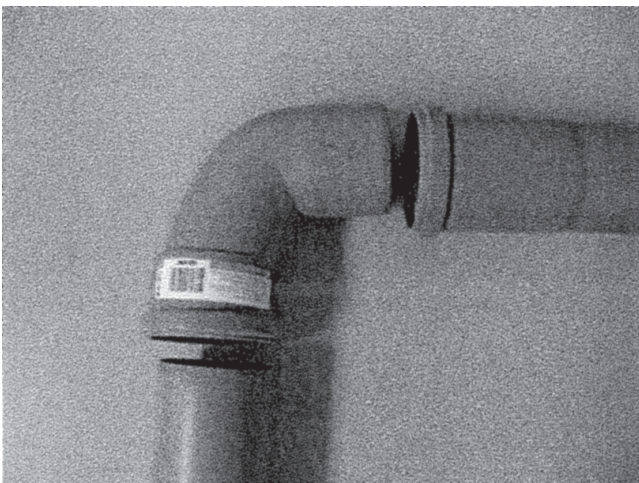
## Installation

The PVC to PP adapter should then be installed into the PVC couplings on the inlet air and exhaust vent installed on the unit. The sealing gasket will require some type of lubricant to make it easier to install the adapter.

Both Centrotherm and M&G Duravent recommend a connector ring to be installed between the PVC part and the PP part. The connector ring for the Centrotherm pipe (either IAFC02, IAFC03, or IAFC04) is shown below. The connector ring for the M&G Duravent pipe is shipped with the PVC to PP adapter..



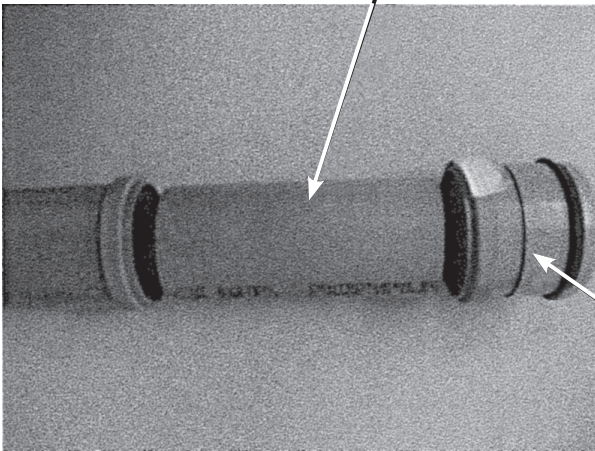
Pipe and fittings are then installed to reach the area for the vent terminations. Each bell end of the pipe has a gasket, which should be lubricated before the next piece of pipe or fitting is installed.



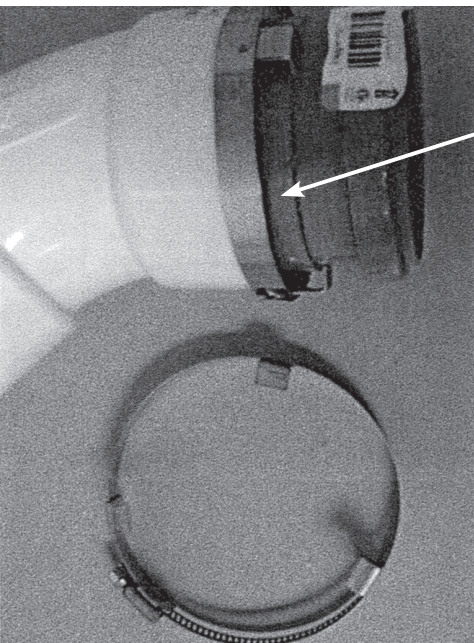
# Installation

To be able to use a PVC termination, a short piece of PP pipe will need to be cut, as shown below, to transition from the bell end of the pipe to the PP to PVC adapter.

Cut a piece of PP pipe that is long enough to go through the wall and have about 2" protruding on each side of the wall.



The PP to PVC adapter can either be installed on the pipe or into the vent terminal for the next step. The final step is to make sure the vent terminal is attached and secured to the adapter.



# Installation Check List

## A. Water Heater Location

- Close to area of vent.
- Indoors and protected from freezing temperatures.
- Proper clearance from combustible surfaces observed and water heater is not installed on a carpeted floor.
- Air supply free of corrosive elements and flammable vapors.
- Provisions made to protect area from water damage.
- Sufficient room to service the heater.

## B. Water Supply

- Water heater completely filled with water.
- Water heater and piping air vented.
- Water connections tight and free of leaks.

## C. Gas Supply

- Gas line equipped with shut-off valve, union, and sediment trap/drip leg.
- Approved pipe joint compound used.
- Minimum pipe size of 3/4"; NO flex pipe.
- Recommended a minimum of 10" WC inlet pressure for natural gas.
- Soap and water solution used to check all connections and fittings for possible gas leak.
- Gas company inspected installation (if required).

## D. Relief Valve

- Discharge line run to open drain.
- Discharge line protected from freezing.

## E. Venting

- All pipe connections are secure (at blower, vent terminals and for each pipe joint connection), and all pipes properly supported.
- Vent terminals mounted properly in allowed locations, with proper clearances .

## F. Condensate

- Condensate trap installed and primed.
- Condensate neutralizer installed (if required).

## G. Wiring

- Correct power supply (120 VAC).
- Electrical connections are tight.
- Water heater is properly grounded with proper polarity.

**TABLE 2**  
For U.S. Installations  
Maximum Capacity of Pipe in Cubic Feet of Gas per Hour for Gas Pressures of  
0.5 psig or Less and a Pressure Drop of 0.3 Inch Water Column  
Based on a 0.60 Specific Gravity Natural Gas; If 1.5 Specific Gravity L.P. Gas is used, multiply capacity by 0.63

Nominal Iron Pipe Size Inches	Internal Diameter Inches	Length of Pipe, Feet													
		10	20	30	40	50	60	70	80	90	100	125	150	175	200
3/4	.824	278	190	152	130	115	105	96	90	84	79	72	64	59	55
1	1.049	520	350	285	245	215	195	180	170	160	150	130	120	110	100
1 1/4	1.380	1,050	730	590	500	440	400	370	350	320	305	275	250	225	210
1 1/2	1.610	1,600	1,100	890	760	670	610	560	530	490	460	410	380	350	320
2	2.067	3,050	2,100	1,650	1,450	1,270	1,150	1,050	990	930	870	780	710	650	610
2 1/2	2.469	4,800	3,300	2,700	2,300	2,000	1,850	1,700	1,600	1,500	1,400	1,250	1,130	1,050	980
3	3.068	8,500	5,900	4,700	4,100	3,600	3,250	3,000	2,800	2,600	2,500	2,200	2,000	1,850	1,700
4	4.026	17,500	12,000	9,700	8,300	7,400	6,800	6,200	5,800	5,400	5,100	4,500	4,100	3,800	3,500

For maximum pipe capacity for installations in Canada, refer to CAN/CSA B149.1. For natural gas, refer to Tables A.1 through A.17. For propane (LP) gas, refer to Tables B.1 through B.12.

# Operation

Before operating this water heater, be sure to read and follow the instructions on the label pictured below and all other labels and warnings on the water heater and printed in this manual. Failure to do so can result in unsafe operation of the water heater resulting in property damage, bodily injury, or death. Should you have any problems reading or understanding the instructions in this manual, STOP, and get help from a qualified person.

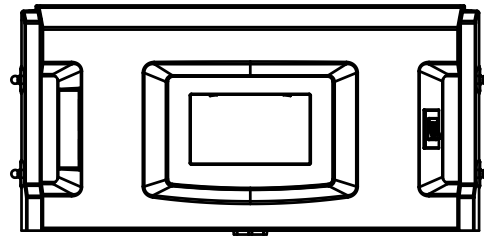
## FOR YOUR SAFETY READ BEFORE OPERATING

**WARNING:** If you do not follow these instructions exactly, a fire or explosion may result causing property damage, personal injury or loss of life.

- A. This appliance does not have a pilot. It is equipped with an ignition device which automatically lights the burner. Do not try to light the burner by hand.
- B. BEFORE OPERATING smell all around the appliance area for gas. Be sure to smell next to the floor because some gas is heavier than air and will settle on the floor.
- WHAT TO DO IF YOU SMELL GAS
- Do not try to light any appliance.
  - Do not touch any electrical switch; Do not use any phone in your building.
  - Immediately call your gas supplier from a neighbor's phone, and follow the gas supplier's instructions.
- If you cannot reach your gas supplier, call the fire department.
- C. Use only your hand to turn the gas control knob. Never use tools. If the knob will not turn by hand, don't try to repair it. Call a qualified service technician. Force or attempt to repair may result in a fire or explosion.
- D. Do not use this appliance if any part has been under water. Immediately call a qualified service technician to inspect the appliance and to replace any part of the control system or any gas control which has been under water.

## OPERATING INSTRUCTIONS

1. STOP! READ THE SAFETY INFORMATION ABOVE ON THIS LABEL.
2. SET THE "ON/OFF" SWITCH NEXT TO THE CONTROL DISPLAY TO THE "OFF" POSITION.
3. THIS APPLIANCE IS EQUIPPED WITH AN IGNITION DEVICE WHICH AUTOMATICALLY LIGHTS THE BURNER.
4. IF YOU THEN SMELL GAS, STOP! FOLLOW "B" IN THE SAFETY INFORMATION ABOVE ON THIS LABEL. IF YOU DON'T SMELL GAS, GO TO THE NEXT STEP.
5. TURN ON ALL ELECTRICAL POWER TO THE APPLIANCE, WITH THE SWITCH LOCATED TO THE RIGHT OF THE CONTROL DISPLAY.
6. IF THE APPLIANCE WILL NOT OPERATE, FOLLOW THE INSTRUCTIONS "TO TURN OFF GAS TO APPLIANCE".
7. WATER TEMPERATURE ADJUSTMENT IS APPROXIMATELY 120°F. SET THE THERMOSTAT TO THE DESIRED TEMPERATURE SETTING



**CAUTION:** HOTTER WATER INCREASES THE RISK OF SCALD INJURY. CONSULT THE INSTRUCTION MANUAL BEFORE CHANGING THE TEMPERATURE.

**WARNING:** TURN OFF ALL ELECTRIC POWER BEFORE SERVICING.

## TO TURN OFF GAS TO APPLIANCE

1. TURN OFF ALL ELECTRIC POWER TO THE APPLIANCE IF SERVICE IS TO BE PERFORMED.
2. TURN THE "MANUAL GAS VALVE KNOB" TO THE "OFF" POSITION.

# Operation

## SAFETY PRECAUTIONS

- A. **DO** turn off manual gas shut-off valve if water heater has been subjected to over heating, fire, flood, physical damage or if gas supply fails to shut off.
- B. **DO NOT** turn on water heater unless it is filled with water.
- C. **DO NOT** turn on water heater if cold water supply shut-off valve is closed.
- D. **DO NOT** store or use gasoline or other flammable vapors and liquids, such as adhesives or paint thinner, in vicinity of this or any other appliance. If such flammables must be used, open doors and windows for ventilation, and all gas burning appliances in vicinity should be shut off, including their pilot lights, to avoid vapors igniting.

**NOTICE: Flammable vapors may be drawn by air currents from surrounding areas to the water heater.**

- E. **DO NOT** allow combustible materials such as newspaper, rags or mops to accumulate near water heater.

- F. If there is any difficulty in understanding or following the OPERATION or MAINTENANCE instructions, it is recommended that a qualified person or serviceman perform the work.

### CAUTION

**Hydrogen gas can be produced in a hot water system served by this water heater that has not been used for a long period of time (generally two weeks or more). HYDROGEN GAS IS EXTREMELY FLAMMABLE!! To dissipate such gas and to reduce risk of injury, it is recommended that the hot water faucet be opened for several minutes at the kitchen sink before using any electrical appliance connected to the hot water system. If hydrogen is present, there will probably be an unusual sound such as air escaping through the pipe as the water begins to flow. DO NOT smoke or use an open flame near the faucet at the time it is open.**

- 1. **TEMPERATURE SETTINGS** — The temperature is adjusted to 120° F when shipped from the factory. To meet commercial water use needs, it is adjustable up to 185°F (85°C). However, water temperatures over 125°F (52°C) can cause severe burns instantly or death from scalds. This is the preferred starting point for setting the control for supplying general purpose hot water.

Safety and energy conservation are factors to be considered when setting the water temperature. The most energy efficient operation will result when the temperature setting is the lowest that satisfies the needs consistent with the application.

### DANGER

**Hotter water increases the potential for hot water SCALDS. When this water heater is supplying general purpose hot water requirements for individuals, a thermostatically controlled mixing valve for reducing point of use water temperature is recommended. Contact a licensed plumber or the local plumbing authority for further information.**

**Outlet water temperature will vary during normal operating cycles. Reliable temperature readings should be taken shortly after main burner cycles off during a period of little or no use.**

- 2. **EMERGENCY SHUTDOWN** —

### WARNING

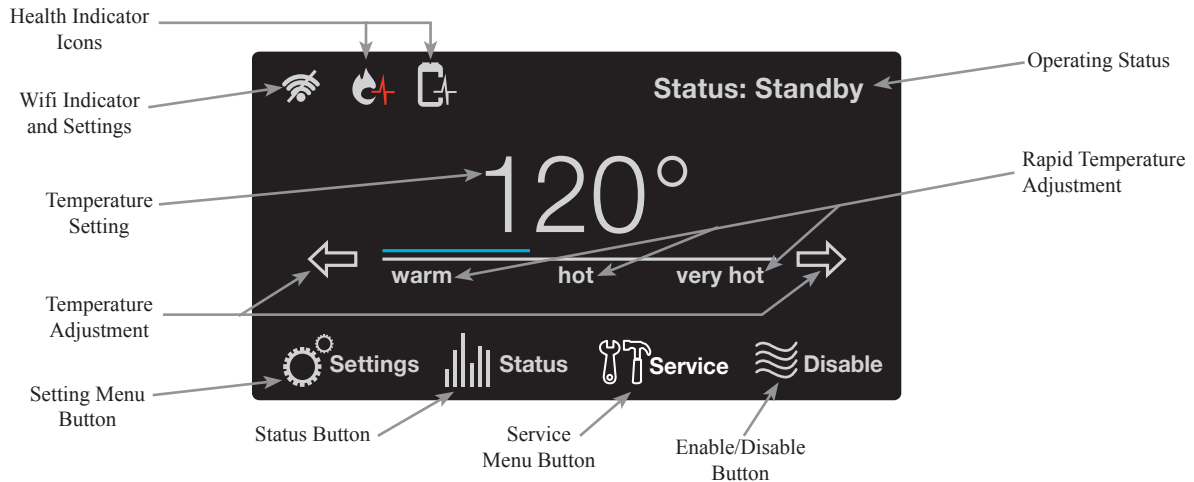
**Should overheating occur or the gas supply fail to shut off, turn off the manual gas control valve to the appliance.**

**DO NOT** use this appliance if any part has been under water. Immediately call a qualified service technician to inspect the appliance and to replace any part of the control system or any gas control which has been under water.

If the water heater has been subjected to fire or physical damage, turn off gas at the manual gas control (shut-off) valve. **DO NOT** operate the water heater again until it has been checked out by a qualified service technician.

# User Interface

## NAVIGATING THE HOME SCREEN:



## Startup

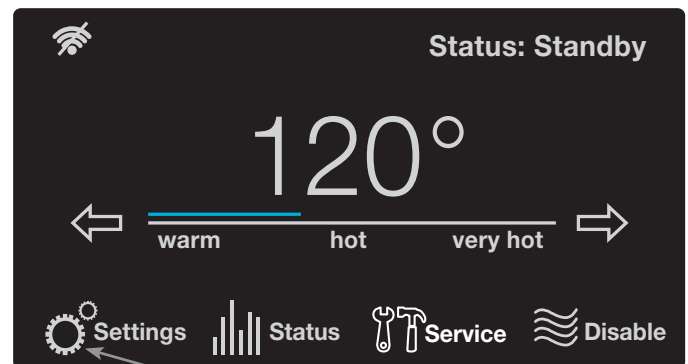
Once power is applied to the water heater and the On button is pressed, the Startup Wizard on the LCD will go over the below features:

1. Setting of Time and Date
2. Setting Hours of Operation for the business
3. Wifi Setup

Follow the on-screen instructions to complete setup. Some of these items can be skipped if a later setup is desired.

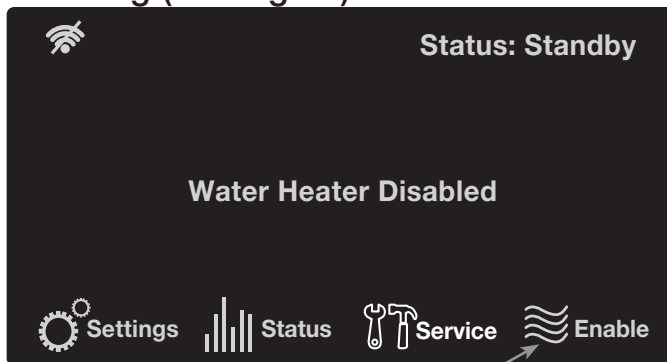
## Setting Menu

The settings function on the water heater display allows access to the basic settings, configurations, schedules, bacnet, and the time/date.

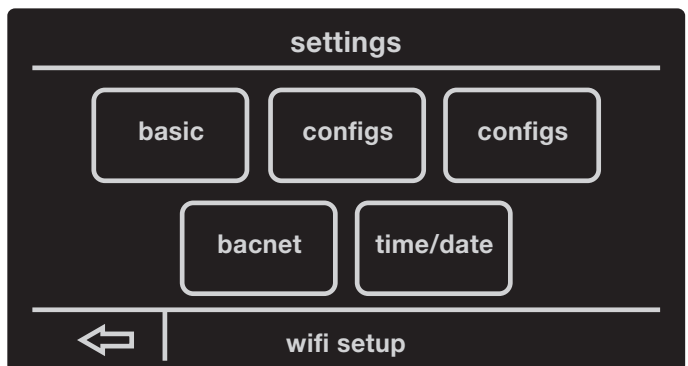


Pressing the settings button will allow access to water heater settings

## Enabling (turning on) the Unit



Press the enable button to turn the water heater on



## Temperature Adjustment

Tank temperature will be maintained according to the setting on the home screen. If the water temperature setting needs adjustment, use the arrows on the display to select desired temperature.

The display also has a rapid temperature adjustment feature that corresponds to the below temperature settings.

Warm: 110°F

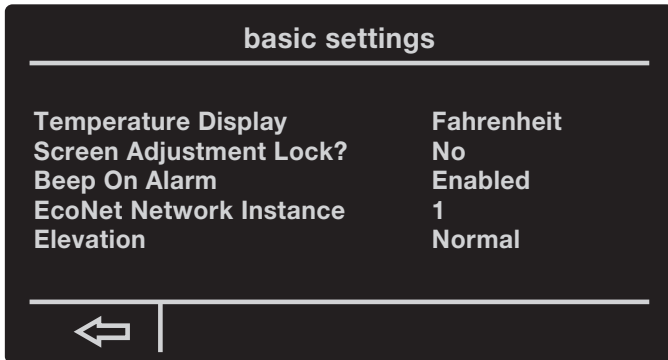
Hot: 140°F

Very hot: 180°F

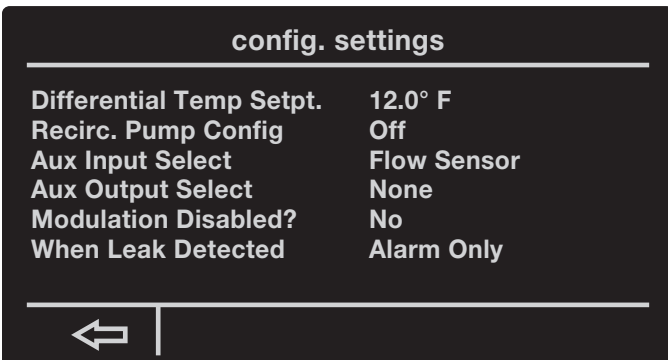
Touching the text 'warm', 'hot', or 'very hot' will adjust the temperature to the above temperature setting.

# User Interface

**BASIC SETTINGS:** The basic settings in your water heater can allow you to change the temperature unit, screen adjustment lock/unlock, enabling/disabling the alarm beep, and your EcoNet network instance. Simply select the setting by tapping it, and press the Up/Down arrows to make adjustments. WiFi setup can be accessed from this screen as well.



**CONFIGURATION SETTINGS:** The configuration settings on your water heater allows you to control the differential temperature set point, turning on/off the recirculation pump, auxiliary input/output, enabling/disabling modulation, and how your hot water heater reacts to a detected leak.



The setting can be highlighted by tapping and then adjusted with the up/down arrows.

The Differential can be adjusted from 1°F to 30°F. The recommended differential is 12°F.

This water heater has a modulation algorithm that can be disabled by tapping 'No' in front of Modulation Disabled and making adjustments by tapping the up/down buttons.

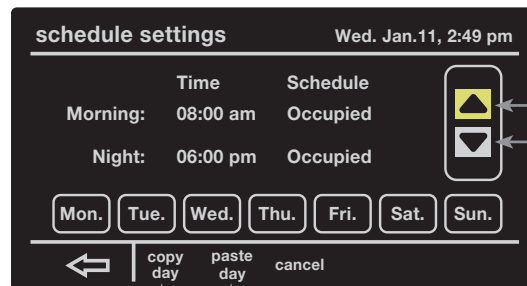
Water heater behavior in response to leak can be changed from Alarm Only to Disable When Leak Detected.

Shutoff Valve (on premium models only) behavior re-

sponse can be selected to the following:

- Open
- Closed
- Close if Leak Detected: Always close the valve when leak is detected.
- Close if Unocc. Leak Detected (based on unoccupied times from the schedule function). Water heater will alarm only during the operating hours.

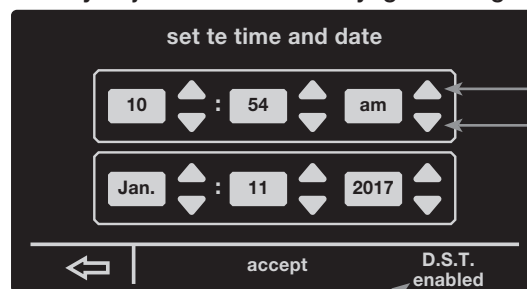
**SCHEDULE SETTINGS:** The schedule settings allows you to control when your hot water heater will be enabled/disabled. Your heater allows you to select a day you want and set the times when the heater will be in use. You can also copy/paste the day you select and apply it to other days as well.



By selecting a day and then accessing the copy function, you can paste that day's settings onto other

The up/down arrows enable you to adjust the time of the morning/night run times.

**TIME/DATE SETTINGS:** By selecting time/date you can change the water heaters current set time. You can also select the daylight savings time function to automatically adjust the time for daylight savings.



The D.S.T function allows you to adjust the time for daylight savings time.

The up/down arrows allow you to control the time, month, day, and year.

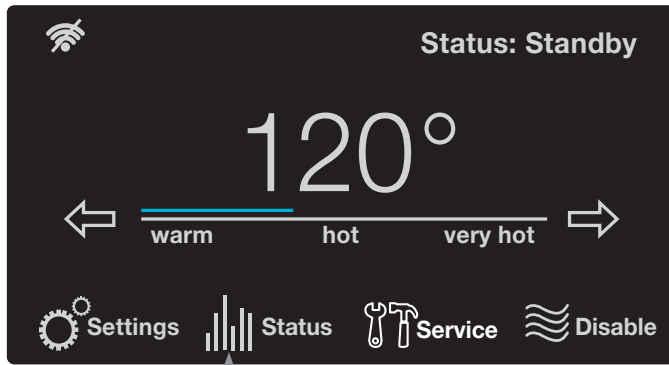
## BacNet

This water heater is compatible with BacNet MS/TP protocol. Please refer to the GHE BacNet instruction sheet for details on the setup.

# User Interface

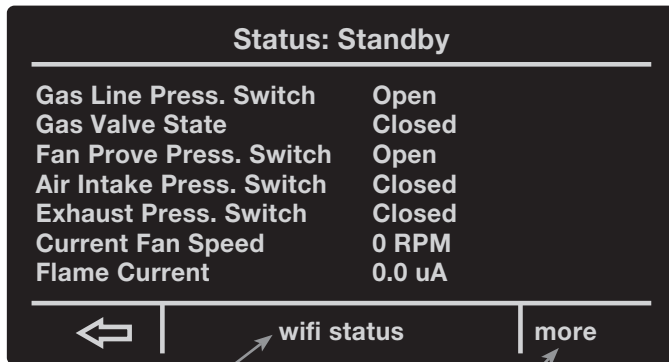
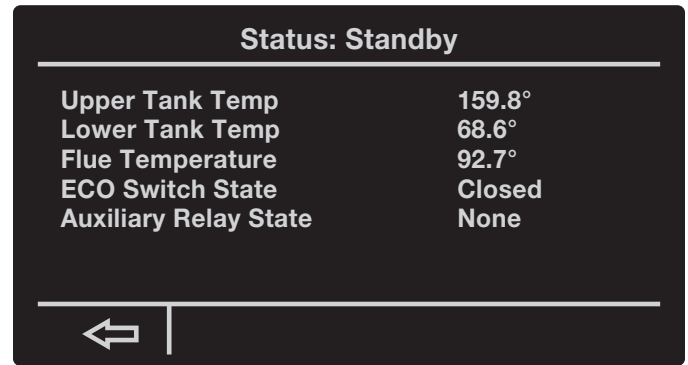
## Status Menu

The Status screen provides information on the current operating status, diagnostics and sensors. This screen also provides information on the WiFi status.



By pressing the Status button, you will be taken to a prompt showing the state of your water heater's many features.

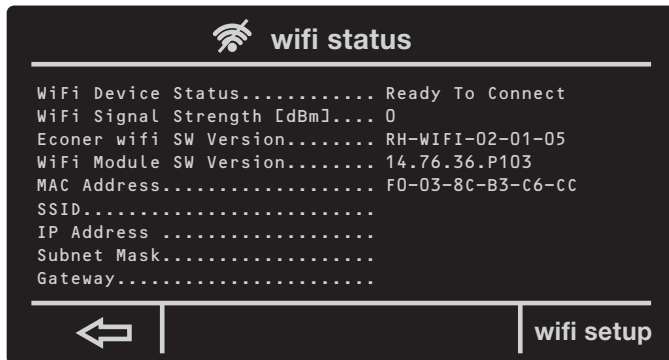
**MORE FUNCTION:** Selecting the more function your heater will bring you to a prompt showing you the current temperatures of the lower/upper tank, Flue temperature, ECO switch state, and Auxiliary relay state.



By selecting Wi-Fi status, you can access the status of your water heater's Wi-Fi and even set it up.

By selecting more, you can access the temperatures of your water heater, ECO switch state, and auxiliary switch state.

**WI-FI STATUS:** After selecting the Wi-Fi status function, you will be brought to a prompt showing you the current state of your water heater's Wi-Fi and the ability to set-up your water heater's Wi-Fi.

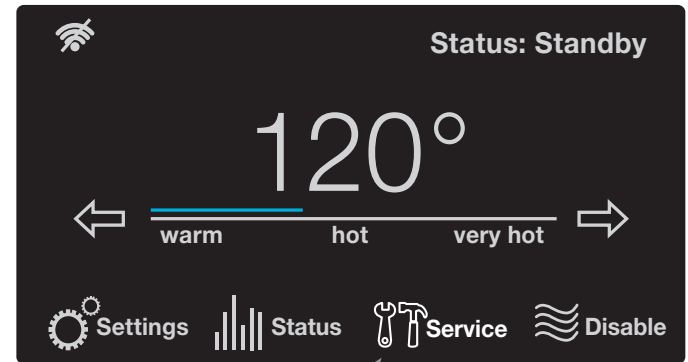


Selecting the Wi-Fi setup function will bring you to a prompt allowing you to connect your water heater to your home Wi-Fi.

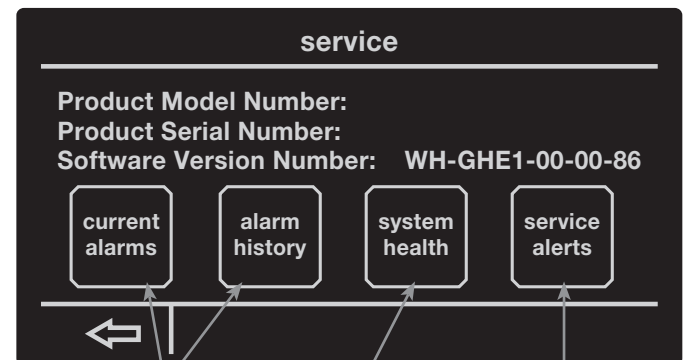
## Service Menu

The service screen provides information on the product description, alarms, system health, and service alerts. Alarm details can be found in the "Before You Call Service" section of the manual.

In case there is an active alarm, the "Service" button will blink on the home screen. Pressing the "Service" button will show a new screen containing the active alarms and alarm history.



By selecting the service function, you will be taken to a prompt giving you access to the heater's alarms, health, and alerts.



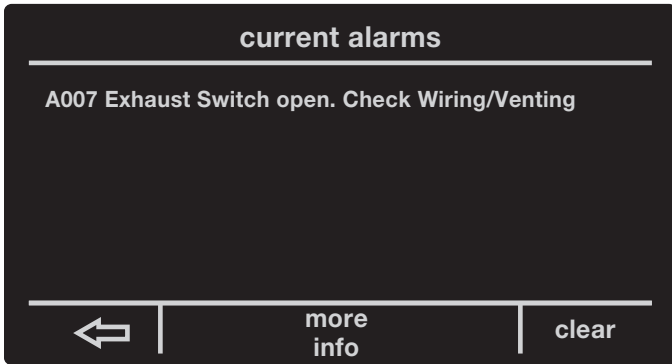
Current Alarms and Alarm History allows you to access any current alarms that have been tripped and view a list of previous alarms.

System Health will show you the status of the tank's combustion health and overall tank health.

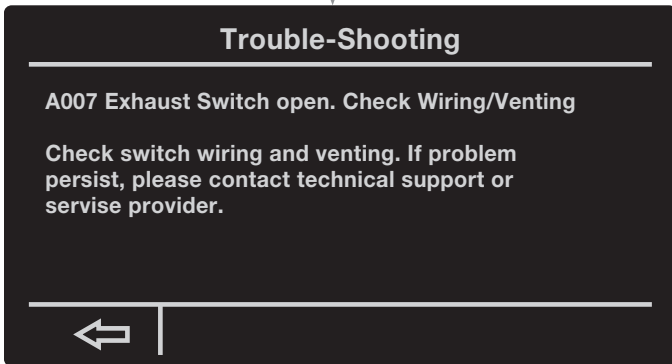
Service Alerts will allow you to set how often you want to be alerted to check venting, clean the drain trap, replace the neutralizer, and to drain and inspect the tank.

# User Interface

**ALARMS:** The current alarms function allows you to see any problems that have been detected by your water heater. Also, by selecting on the current alarm you can press “more info” to read more on the current problem of your water heater. Alarm history allows you to see any of the previous alarms that have gone off in the past and give you the ability to clear those previous alarms.



By selecting “more info” you can be given a more in-depth explanation of the current alarm.



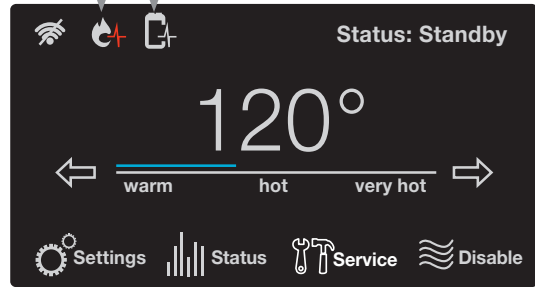
**ALARM HISTORY:** The alarm history function allows you to see the previous alarms that have been detected by your water heater in the past.



**SYSTEM HEALTH:** The system health function allows you to see the current health of your hot water heater’s combustion health and tank health status. The combustion health and tank health each have three levels of health:

This symbol will appear on your home screen if your combustion health is critical. Pressing this icon will take the user to the Health Status Screen

This symbol will appear if your tank health status has reached critical. Pressing this icon will take the user to the System Health Screen

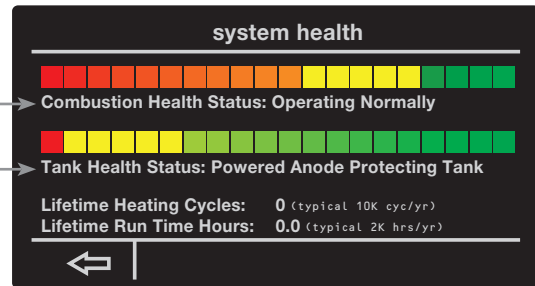


**COMBUSTION HEALTH:**

1. Normal operation  
-no action needed
2. Reliability Decreasing  
-begin planning for service and/or replacement.
3. Needs Servicing  
-contact your service provider

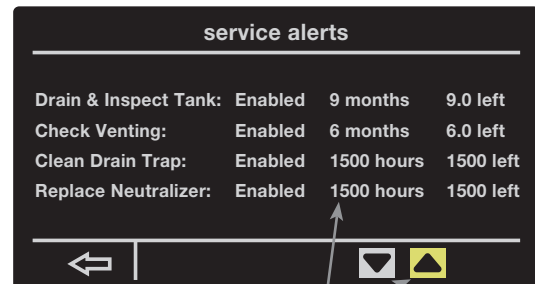
**TANK HEALTH:**

1. Powered anode protecting tank  
-no action needed
2. Anode protection ending  
-begin planning for service and/or replacement.
3. Anode no longer protecting tank.  
-contact your service provider



The health of your system’s combustion system and overall health can be seen here. This screen be accessed by tapping the health indicator icons on the home screen.

**SERVICE ALERTS:** By selecting the Service alerts function you will be able to adjust how often you want to be alerted to drain and inspect the tank, clean the drain trap, check the venting, and to replace the neutralizer.



By selecting an option and then using the up and down arrow, you can set how often you’d like to be alerted to system maintenance.

# Maintenance

Properly maintained, this water heater will provide years of dependable, trouble free service. It is strongly suggested that a regular routine maintenance program be established and followed by the owner. It is further recommended that a periodic inspection of the relief valve and venting system should be made by service technicians qualified in gas appliance repair.

## 1. ROUTINE PREVENTIVE MAINTENANCE

- A. **PRESSURE SWITCH** — Inspect the inlet to the pressure switch and the tubing for debris or blockage. Clean out the tubing periodically to prevent buildup of debris.
- B. **COLLECTOR PAN** — Remove any particles.
- C. **CONDENSATE TRAP** — Check for blockages.
- D. **ELECTRICAL CONNECTIONS** — Periodic inspection of all electrical connections and wiring conditions.

### CAUTION

Label all wires prior to disconnection when servicing controls. Wiring errors can cause improper and dangerous operation.

### CAUTION

#### VERIFY PROPER OPERATION AFTER SERVICING !

Make certain all power to the water heater is turned "OFF" before performing any maintenance or inspection work on this water heater.

Before manually operating the relief valve, make certain no one will be exposed to the danger of coming in contact with the hot water released by this valve. The water may be hot enough to create a SCALD hazard. The water released should be directed to a suitable drain to prevent injury or damage.

**NOTICE:** If the temperature and pressure relief valve on the water heater discharges periodically, this may be due to thermal expansion in a "closed" water system. Contact the water supplier or local plumbing inspector on how to correct this. **DO NOT** plug the relief valve outlet.

- E. **TANK**— Good maintenance requires that the tank be cleaned of deposits. Unless the water supply is soft (0 to 5 grains hardness), scale or lime deposits will accumulate in the tank. Hard water scale is deposited at an increasingly high rate in proportion to increased water temperature. Accumulation of these deposits may reduce efficiency, and shorten the life of the water heater.

Any new installation should have a tank inspection program set up initially for frequent inspection. The first inspection should be within a six month period. Once the scaling tendencies have been established, the inspection program can be modified to suit the water conditions. Cleaning should be performed if the scale has accumulated above the drain valve opening.

A wet-dry shop vac with a nozzle fashioned from 1" and/or 3/4" polyethylene pipe makes a good tool for scraping and removing scale.

#### TO CLEAN OR INSPECT TANK:

1. Shut off gas valve and drain tank.
2. Remove the tank clean-out cover on the jacket and, with a pocket knife, cut and remove a circular plug of insulation the full size of the jacket opening.
3. Loosen the nut on the seal plate assembly enough to twist the yoke sideways. Hold the assembly securely and push inward, then remove the assembly from the tank.
4. Remove as much built-up scale from the flue tubes and the tank bottom as practical. Do not allow the cleaning tool to damage the glass lining.
5. Clean the seal plate and install a new gasket. Wipe clean the interior surface of the tank that contacts the gasket. Reinstall the seal plate and tighten in position. Fill the tank with water and check for leaks. If no leaks are found, install the insulation plug and clean-out cover on the jacket and re-light the water heater.

If chemical lime dissolving cleaners are preferred, cautiously follow the instructions supplied with the cleaner. **DO NOT** use a muriatic or hydrochloric acid (HCl) base cleaner.

2. **SEASONAL OPERATION** - If the water heater is to remain idle for an extended period (60 days or more) the heater should be turned off. The water heater and piping should be drained if they might be subjected to freezing temperatures. It is recommended that the water heater's operation is thoroughly checked (by a qualified service technician) before it is placed back in service. **NOTICE:** Refer to the Hydrogen Gas caution notation on page 32.
- F. **VENTING SYSTEM** — Inspect the venting system at least yearly to make certain the passageways are free and unobstructed, and that the vent connector from the water heater's blower assembly is properly positioned and securely attached. Remove any obstructions in the vent connector or vent terminal.

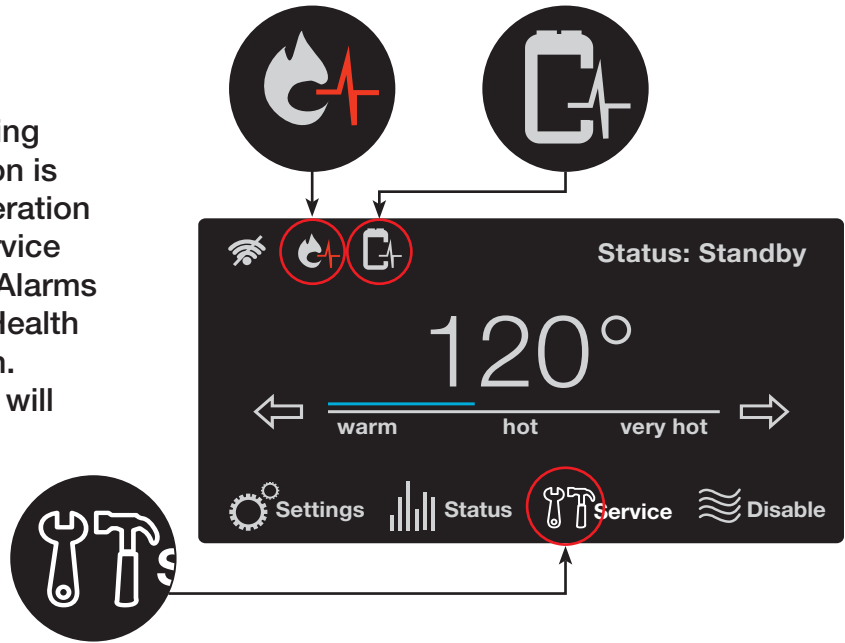
# Before You Call For Service...



## Troubleshooting Tips

Save time and money! Review the charts on the following pages first and you may not need to call for service.

If one of the health indicators is blinking on the home screen or the service icon is blinking there is an issue with the operation of your water heater. Pressing the service icon will allow you to look at Current Alarms (and Alerts), Alarm History, and Unit Health screens for issues that need attention. Pressing the blinking health indicator will show the health screen.



Problem	Possible Causes	What To Do
Display not on	No power to the unit	Check the breaker to the unit, the on/off switch, and the fuse on the ignition control board.
	Harness from control board disconnected	Make sure that the wire harness to J4 on the ignition control board is still connected.
Blower does not run	No power to blower motor	Verify power to the control board and that all harnesses to the blower are properly installed. Make sure that there is no damage the harnesses or connectors.
Unable to light the main burner	Air in gas line	Let the unit cycle at least 3 times to remove air from the gas line. If the unit does not try to light, contact a qualified service technician to purge the air from the gas line.
	Manual gas shut-off valve(s) not open	Check to make sure that all manual shut-off valves between the unit and the gas line are open.
	Blocked inlet or exhaust vent pipe	Contact a qualified service technician to evaluate vent pipes for a blockage.
	Pressure switch	Make sure the pressure switch hoses are not "kinked" or disconnected.
		Blocked inlet or outlet vent systems will cause pressure switch to shut off the unit. Contact a qualified service technician to evaluate the vent system.
Wire connection not fully secured	Contact a qualified service technician to confirm wire connections.	

# Before You Call For Service...



## Troubleshooting Tips

Save time and money! Review the charts on the following pages first and you may not need to call for service.

Problem	Possible Cause	What To Do
Unable to light the main burner	Gas control problem	Contact a qualified service technician.
	Unit or electrical supply line not properly grounded	Verify that the electrical supply line and unit have proper ground connection.
Main burner does not stay lit	Burner flame not contacting sensor rod.	Call a qualified service technician to review flame rectification.
	Unit or electrical supply line not properly grounded	Verify the electrical supply line and unit have proper ground connection.
Not enough or no hot water	Water usage exceeded the capacity	Wait for the water heater to recover after an abnormal demand of the water heater.
	Low gas pressure	Check the gas supply pressure.
	Water heater set point is set too low	See the "User Interface" section of this manual to the set point temperature.
	Leaking or open hot water faucets	Make sure all faucets are closed.
	"ON/OFF" switch turned off	Turn the switch to the "ON" position.
	Colder supply water	Incoming water temperature might be lower than when the unit was initially installed. This will require a longer heat up cycle.
	Burner not staying on	Refer to the "Main Burner" section of this manual.
Water is to hot	The water heater set point is set too high	See the "User Interface" section of this manual to the set point temperature.

### CAUTION

Make certain power to the water heater is "OFF" before removing the protective cover FOR ANY REASON.

### CAUTION

Label all wires prior to disconnection when servicing controls. Wiring errors can cause improper and dangerous operation. VERIFY PROPER OPERATION AFTER SERVICING!

### CAUTION

For your safety, **DO NOT** attempt repair of gas piping, gas control burner, vent connectors or other safety devices. Refer repairs to qualified service personnel.

**NOTE:** A GHE Training Manual is available through the Technical Services Department for a more detailed troubleshooting and repair guide.

# Before You Call For Service...

Alarm ('A') and Alert ('T') Codes	Description	Current Alarm Screen Display
A001	Ignition lockout due to a total of 9 consecutive failed ignitions. <b>This will disable the heater.</b>	A001 Ignition lockout. ->Clear error code by turning the unit off/on. If problem persists, please contact technical support or service provider.
A002	Flame not stable lockout. Lost flame three times during one heat cycle. <b>This will disable the heater.</b>	A002 Flame is not stable. ->Clear error code by turning the unit off/on. If problem persists, please contact technical support or service provider.
A003	The intake pressure switch was detected open when the blower was running. <b>This will disable the heater.</b>	A003 Intake Switch open. Check Wiring/Venting ->Check switch wiring and venting. If problem persists, please contact technical support or service provider.
A004	The proof of air flow switch was detected open during heating operation. <b>This will disable the heater.</b>	A004 PoF Switch error H. Check Blower/Wiring. ->Check switch wiring and venting. If problem persists, please contact technical support or service provider.
A005	The proof of air flow switch was detected open during pre-purge operation. <b>This will disable the heater.</b>	A005 PoF Switch error E. Check Blower/Wiring. ->Check switch wiring and venting. If problem persists, please contact technical support or service provider.
A006	The proof of air flow switch was detected open during post purge operation.	A006 PoF Switch error P. Check Blower/Wiring. ->Check switch wiring and venting. If problem persists, please contact technical support or service provider.
A007	Exhaust flue pressure switch was detected open during heating. <b>This will disable the heater.</b>	A007 Exhaust Switch open. Check Wiring/Venting ->Check switch wiring and venting. If problem persists, please contact technical support or service provider.
A008	The proof of air flow pressure switch was detected closed before the blower started operation. <b>This will disable the heater.</b>	A008 PoF Switch/Blower mismatch. Call Tech Svc ->The Proof of Fan pressure switch is closed when the blower is off. Please contact technical support or service provider.
T009	Gas pressure is below minimum specified. This will cause difficulties lighting the unit.	T009 No Gas detected. Check gas connections ->Verify gas supply to the unit. Check wiring to the gas pressure switch. If problem persists contact technical support.

## Before You Call For Service...

Alarm ('A') and Alert ('T') Codes	Description	Current Alarm Screen Display
A016	Energy Cutout (ECO) switch is open. <b>This will disable the heater.</b>	A016 High Tank Temperature. Call Tech Service. ->Clear error code by pressing clear button. Refer to use and care manual for troubleshooting, or contact technical support.
A017	Flue (exhaust) gas temperature has exceeded 155°F. <b>This will disable the heater.</b>	A017 High Flue Temp. Recycle unit ON/OFF. ->Blower will continue to run until exhaust temperature has decreased. If problem persists please contact technical support.
A018	Flue temperature sensor (thermistor) detected open. <b>This will disable the heater.</b>	A018 Flue Temp Sensor open. Check wiring. ->Check wiring to sensor. If condition persists refer to use and care manual or contact technical support.
A019	Flue temperature sensor (thermistor) detected short circuited. <b>This will disable the heater.</b>	A019 Flue Temp Sensor shorted. Call Tech Svc. ->Check wiring to sensor. If condition persists refer to use and care manual or contact technical support.
T020	Lower tank (inlet) temperature sensor (thermistor) detected open.	T020 Lower Tank Sensor open. Check wiring. ->Check wiring to sensor. If condition persists refer to use and care manual or contact technical support.
T021	Lower tank (inlet) temperature sensor (thermistor) detected short circuited.	T021 Lower Tank Sensor shorted. Call Tech Svc. ->Check wiring to sensor. If condition persists refer to use and care manual or contact technical support.
A022	Upper tank temperature sensor detected open. <b>This will disable the heater.</b>	A022 Upper Tank Sensor open. Check wiring. ->Check wiring to sensor. If condition persists refer to use and care manual or contact technical support.
A023	Upper tank temperature has exceeded 205°F. <b>This will disable the heater.</b>	A023 Upper Tank temp. too hot. Call Tech Svc. ->Clear error code by pressing clear button. Refer to use and care manual for troubleshooting, or contact technical support.
A024	Upper tank temperature sensor detected short circuited. <b>This will disable the heater.</b>	A024 Upper Tank sensor shorted. Call Tech Svc. ->Check wiring to sensor. If condition persists refer to use and care manual or contact technical support.

## Before You Call For Service...

Alarm ('A') and Alert ('T') Codes	Description	Current Alarm Screen Display
A025	Control does not detect blower RPM. <b>This will disable the heater.</b>	A025 No Blower RPM feedback. Call Tech Service ->Please contact technical support or service provider.
A026	Blower RPM feedback (actual RPM) is $\geq 300$ RPM from desired RPM for > 1 minute.	A026 Blower expected RPM vs actual RPM mismatch ->Please contact technical support or service provider.
A027	Flame current detected prior to opening gas valve. <b>This will disable the heater.</b>	A027 Flame present before ignit. Call Tech Svc ->Clear error code by turning the unit off and on. If problem persists please contact technical support or service provider.
A028	Flame current detected 10 seconds after closing gas valve. <b>This will disable the heater.</b>	A028 Flame present w/o heating. Call Tech Svc. ->Clear error code by turning the unit off and on. If problem persists please contact technical support or service provider.
A029	Unit did not ignite.	A029 Failed ignition. Retrying.
A030	Unit lost flame.	A030 Flame lost during heating. Retrying.
A031	Powered anode control is no longer communicating with the ignition control. This will override any other anode based alarms.	A031 Powered Anode Communication failure ->Unit will continue to operate. Please contact your qualified service provider.
T032	Lower (inlet) thermistor analog to digital converter fault.	T032 Lower Tank temp A/D error. Call Tech Svc. ->If problem persists, please contact technical support or service provider.
A033	Exhaust flue thermistor analog to digital converter fault. <b>This will disable the heater.</b>	A033 Flue sensor A/D error. Call Tech Service. ->If problem persists, please contact technical support or service provider.
A034	Upper tank thermistor analog to digital converter fault. This will disable the heater.	A034 Upper Tank temp A/D error. Call Tech Svc. ->If problem persists, please contact technical support or service provider.
T035	Gas relay #1 contacts did not close. The unit will continue to try and close the relay to initiate combustion.	A035 Gas Relay 1 stuck open. Call Tech Service ->If problem persists, please contact technical support or service provider.
A036	Gas relay #1 stuck closed. This could inadvertently allow the gas valve to open. <b>This will disable the heater.</b>	A036 Gas Relay 1 stuck closed. Call Tech Svc. ->If problem persists, please contact technical support or service provider.

## Before You Call For Service...

Alarm ('A') and Alert ('T') Codes	Description	Current Alarm Screen Display
A037	Gas relay #2 contacts failed to properly close. This can cause gas valve cycling and gas buildup in the burn chamber. <b>This will disable the heater.</b>	A037 Gas Relay 2 stuck open. Call Tech Service ->If problem persists, please contact technical support or service provider.
A038	Gas relay #2 stuck closed. This could inadvertently allow the gas valve to open. <b>This will disable the heater.</b>	A038 Gas Relay 2 stuck closed. Call Tech Svc. ->If problem persists, please contact technical support or service provider.
A039	This is a control board hardware fault and requires control board replacement if persistent. <b>This will disable the heater.</b>	A039 Flame sense cct fault. Call Tech Service ->If problem persists, please contact technical support or service provider.
A040	This is a control board hardware fault and requires control board replacement if persistent. <b>This will disable the heater.</b>	A040 Controller RAM fault. Call Tech Service. ->If problem persists, please contact technical support or service provider.
A041	This is a control board hardware fault and requires control board replacement if persistent. <b>This will disable the heater.</b>	A041 Controller ROM fault. Call Tech Service. ->If problem persists, please contact technical support or service provider.
A042	This is a control board hardware fault and requires control board replacement if persistent. <b>This will disable the heater.</b>	A042 Controller EEPROM fault. Call Tech Svc. ->If problem persists, please contact technical support or service provider.
A043	This is a control board hardware fault and requires control board replacement if persistent. <b>This will disable the heater.</b>	A043 IC Program execution fault. Call Tech Svc ->If problem persists, please contact technical support or service provider.
A044	Input power frequency not 60 Hz. (outside allowable deviation). <b>This will disable the heater.</b>	A044 Processor Clock/Line Frequency Disagree ->If problem persists, please contact technical support or service provider.
A101	This is a display board hardware fault and requires control board replacement if persistent. <b>This will disable the heater.</b>	A101 Configuration Data Restore Failure ->Initialization of the control system failed at startup. Please contact technical support or service provider.
A102	Set the internal clock time.	A102 Time Clock needs to be programmed ->Go to Settings, select time/date menu and set the time and date.
A103	This is a display board hardware fault and requires control board replacement if persistent. <b>This will disable the heater.</b>	A103 Time Clock not advancing time properly ->Please contact your qualified service provider.
A104	Presence of water detected by the leak sensor in the bottom pan. If water is seen locate source and take appropriate action to correct the issue. <b>This may disable the heater based on configuration settings.</b>	A104 Water Leak Detected ->The presence of water has been detected by the control. Please contact a qualified service provider.

## Before You Call For Service...

Alarm ('A') and Alert ('T') Codes	Description	Current Alarm Screen Display
T105	Check to see if leak sensor is installed in the bottom pan. Check wiring on connector P11 of the ignition control board.	T105 Water Leak Sensor Not Installed ->Check water leak sensor connection. Refer to use and care manual for troubleshooting, or contact technical support.
A108	Communication lost between the display board and the ignition control board. The ignition control board will continue to operate the heater using the last known configuration settings. Check wiring between the display and P5 of the ignition control board.	A108 Ignition Board Communication Failure ->Communications lost with ignition control board. If problem persists, contact technical support or service provider.
A109	CO sensor detects presence of carbon monoxide gas above the threshold limit. <b>This will disable the heater.</b>	A109 External CO Sensor Alarm: Heater Disabled ->Immediately contact a qualified service provider.
A110	Monthly test of automatic shutoff valve (premium models only) was not completed properly. The valve did not close in the allotted time.	A110 Shutoff Valve Test Close Error ->Auto Shutoff valve failed to close during test cycle. Please contact technical support or service provider.
A111	Monthly test of automatic shutoff valve (premium models only) was not completed properly. The valve did not open in the allotted time. <b>This will disable the heater.</b>	A111 Shutoff Valve Test Open Error ->Water heater has been disabled. Manually open valve. Please contact technical support or service provider.
A112	Automatic shutoff valve (premium models only) is closed. <b>This will disable the heater.</b>	A112 Shutoff Valve Not Open: Heating Disabled ->Manually open valve if no water detected or if unit is not being serviced. Contact technical support or service provider.
T113	Peak flame rod current has deviated from the startup average. This is indicative of degradation of the flame rod (dirty, sooty). It needs to be cleaned and inspected .	T113 Flame Rod Degraded and Needs Servicing ->Clean or replace per use and care manual. Please contact technical support for assistance.
T114	Peak flame rod current has deviated from the startup average by a significant amount. Clean and inspect flame rod. Replace if necessary.	T114 Flame Rod Degraded and Needs Servicing ->Clean or replace per use and care manual. Please contact technical support for assistance.
A115	Monitored characteristics of the combustion system indicate degraded performance. Combustion system needs to be inspected and serviced.	T115 Combustion Health Degraded: Needs Service ->Combustion system performance is degraded. Please contact technical support or service provider for assistance.
A116	Monitored characteristics of the combustion system indicate severely degraded performance. Combustion system needs to be inspected and serviced.	T116 Combustion Health Degraded. Needs Service ->Clear error code by pressing clear button. Refer to use and care manual for troubleshooting, or contact technical support.

## Before You Call For Service...

Alarm ('A') and Alert ('T') Codes	Description	Current Alarm Screen Display
T117	Periodic maintenance, inspection, and upkeep on the unit.	T117 Time to Drain and Inspect Tank ->Refer to the use and care manual for instructions, or contact technical support or service provider.
T118	Periodic maintenance, inspection, and upkeep on the unit.	T118 Time to Check Venting for Debris ->Refer to the use and care manual for information, or contact technical support or service provider.
T119	Periodic maintenance, inspection, and upkeep on the unit.	T119 Time to Clean Out the Condensate Drain Trap ->Refer to the use and care manual for instructions and locations. Call technical support or service provider if necessary.
T120	Periodic maintenance, inspection, and upkeep on the unit.	T120 Time to Replace the Neutralizer ->Clear error code by pressing clear button. Refer to use and care manual for troubleshooting, or contact technical support.
A121	One or more powered anodes do not sense water in the tank. This can also be caused by an "open" circuit on an anode. Check anode wiring. Ensure tank is completely full. <b>This will disable the heater.</b>	A121 No Water Detected in Tank ->Fill the tank with water. If error persists, please contact technical support or service provider.
T122	No communication with the powered anode controller for >60 seconds. If the green LED on top of the anode control is solid, the anodes are still protecting the tank.	T122 Powered Anode Control Comm Failure ->Check wiring connections of the anode control board. If error persists, please contact technical support or service provider.
T123	Anode "open" circuit. This can be caused by wiring damage, wiring disconnected, or anode damage.	T123 Upper Anode Open ->Check wiring connections for the upper anode. If error persists, please contact technical support or service provider.
T124	Anode control common and the power connection for this anode cross connected.	T124 Upper Anode Mounting Error ->Check wiring connections for the upper anode. If error persists, please contact technical support or service provider.
T125	Anode "short" circuited. This can be caused by wiring damage, anode damage, or the anode in contact with the tank.	T125 Upper Anode Shorted ->Check wiring connections for the upper anode. If error persists, please contact technical support or service provider.
T126	Anode power = 100%. The anode system has reached its protective limits on one or more anode elements.	T126 Upper Anode Overload ->Upper Anode has reached full capacity. Tank may not be fully protected. Please contact technical support or service provider.
T127	Anode power > 70%. The anode system is approaching its protective limits on one or more anode elements.	T127 Upper Anode Pre-Overload ->Upper Anode near end of useful life but will continue protecting tank. Please contact technical support.

## Before You Call For Service...

---

Alarm ('A') and Alert ('T') Codes	Description	Current Alarm Screen Display
T128	Anode "open" circuit. This can be caused by wiring damage, wiring disconnected, or anode damage.	T128 Middle Anode Open ->Check wiring connections for the middle anode. If error persists, please contact technical support or service provider.
T129	Anode control common and the power connection for this anode cross connected.	T129 Middle Anode Mounting Error ->Check wiring connections for the middle anode. If error persists, please contact technical support or service provider.
T130	Anode "short" circuited. This can be caused by wiring damage, anode damage, or the anode in contact with the tank.	T130 Middle Anode Shorted ->Check wiring connections for the middle anode. If error persists, please contact technical support or service provider.
T131	Anode power = 100%. The anode system has reached its protective limits on one or more anode elements.	T131 Middle Anode Overload ->Middle Anode has reached full capacity. Tank may not be fully protected. Contact technical support or service provider.
T132	Anode power > 70%. The anode system is approaching its protective limits on one or more anode elements.	T132 Middle Anode Pre-Overload ->Middle Anode near end of useful life but will continue protecting tank. Please contact technical support.
T133	Anode "open" circuit. This can be caused by wiring damage, wiring disconnected, or anode damage.	T133 Lower Anode Open ->Check wiring connections for the upper anode. If error persists, please contact technical support or service provider.
T134	Anode control common and the power connection for this anode cross connected.	T134 Lower Anode Mounting Error ->Check wiring connections for the lower anode. If error persists, please contact technical support or service provider.
T135	Anode "short" circuited. This can be caused by wiring damage, anode damage, or the anode in contact with the tank.	T135 Lower Anode Shorted ->Check wiring connections for the lower anode. If error persists, please contact technical support or service provider.
T136	Anode power = 100%. The anode system has reached its protective limits on one or more anode elements.	T136 Lower Anode Overload ->Lower Anode has reached full capacity. Tank may not be fully protected. Contact technical support or service provider.
T137	Anode power > 70%. The anode system is approaching its protective limits on one or more anode elements.	T137 Lower Anode Pre-Overload ->Lower Anode near end of useful life but will continue protecting tank. Please contact technical support.

# Replacement Parts

## Instructions For Placing a Parts Order

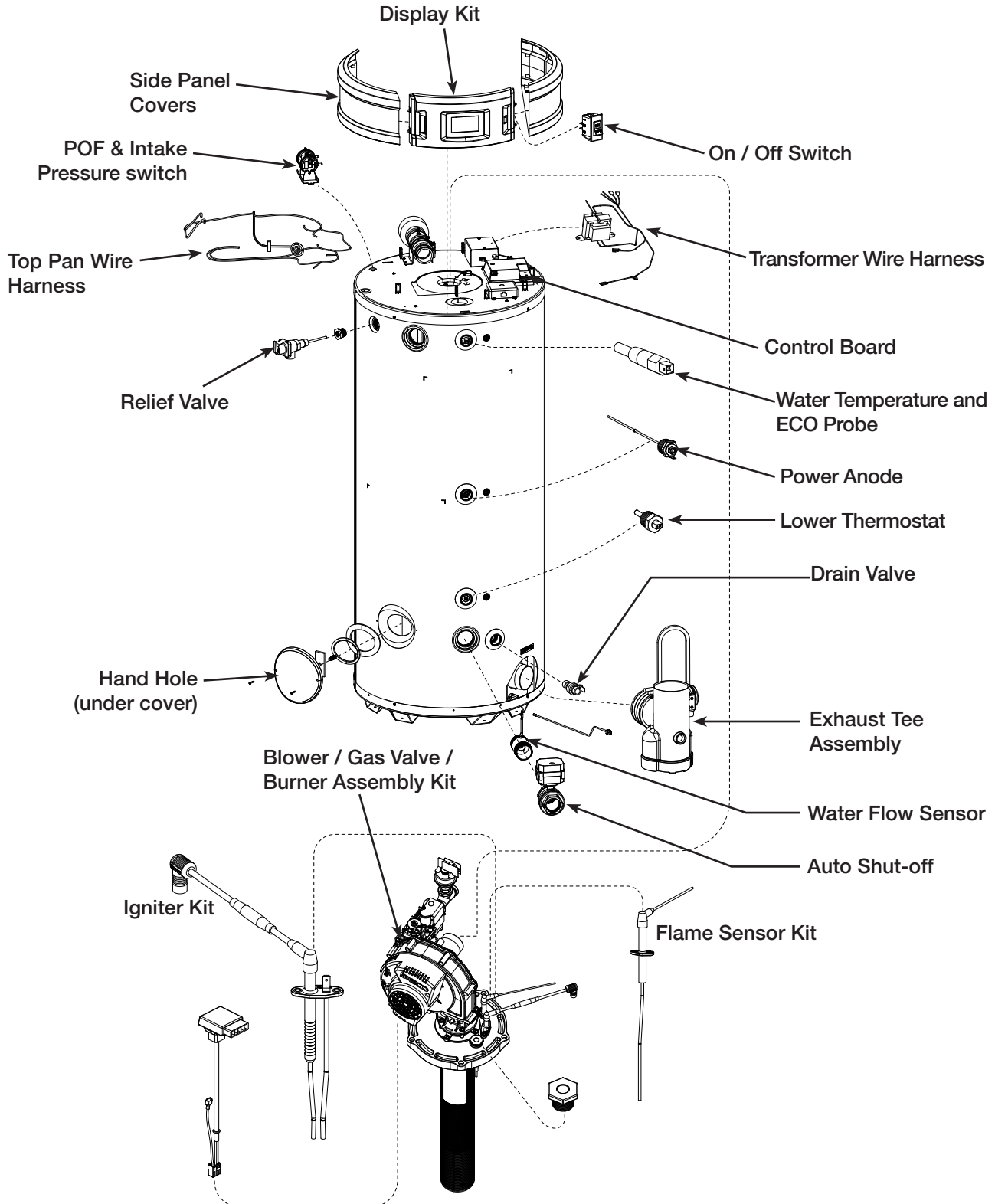
All parts orders should include:

The model and serial number of the water heater from the rating plate.

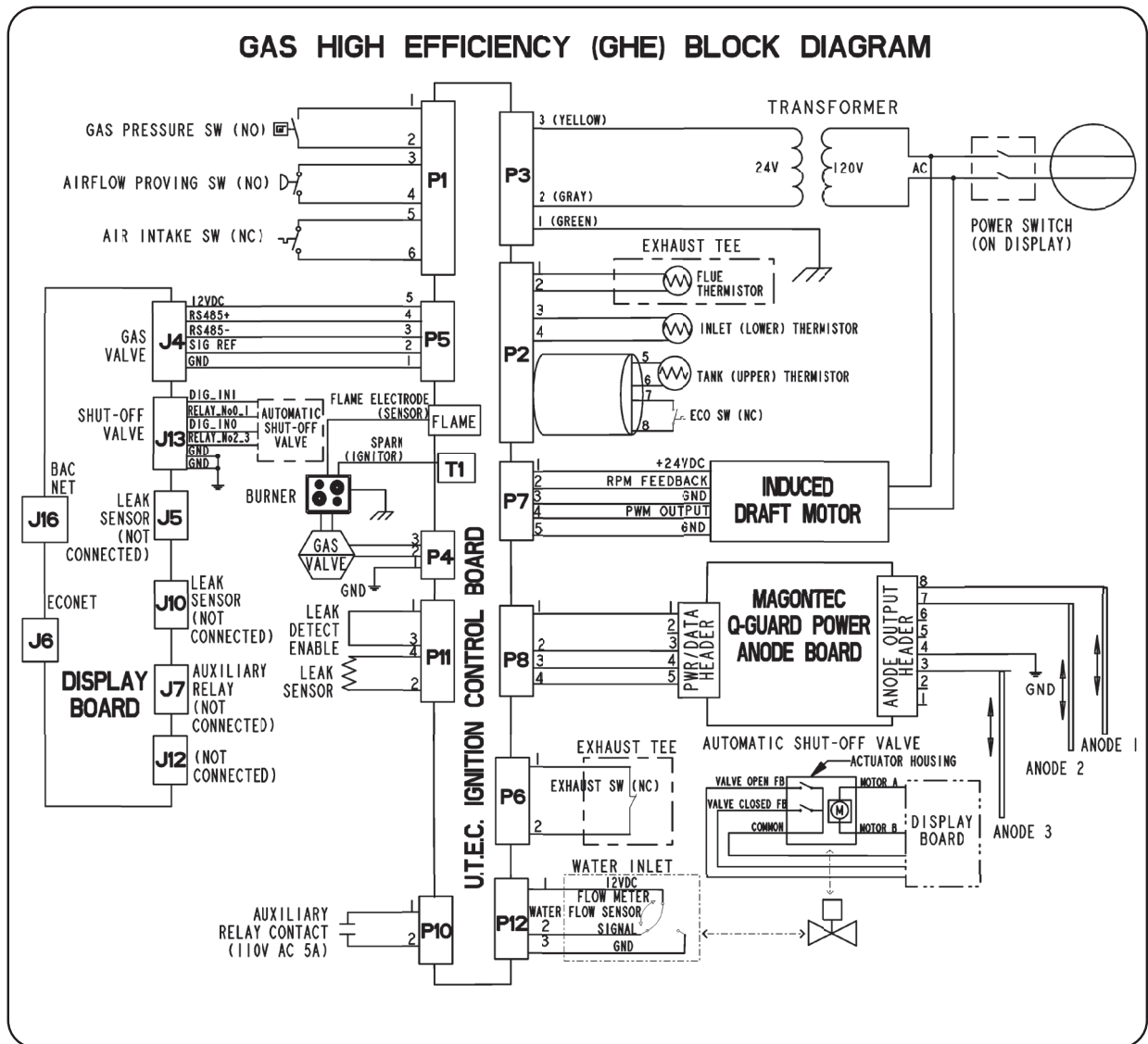
Specify type of gas (natural or LP) as marked on the rating plate.

Part description (as noted below) and number of parts desired.

**▲ CAUTION:** For your safety **DO NOT** attempt repair of gas piping, gas control burner, vent connectors or other safety devices. Refer repairs to qualified service personnel.



# Wiring and Schematic Diagrams



### **CAUTION**

Label all wires prior to disconnection when servicing controls. Wiring errors can cause improper and dangerous operation. **VERIFY PROPER OPERATION AFTER SERVICING!**

---

NOTES:

---

---

NOTES:

---

---

**NOTES:**

---

# How to Obtain Service Assistance

1. Should you have any questions about your new water heater, or if it requires adjustment, repair, or routine maintenance, it is suggested that you first contact your installer, plumbing contractor or previously agreed upon service agency. In the event that the firm has moved, or is unavailable, refer to the telephone directory commercial listings or local utility for qualified service assistance.
2. Should your problem not be solved to your complete satisfaction, you should then contact the Manufacturer's National Service Department at one of the following addresses:

In The U.S.A.:

Rheem Manufacturing Co., Water Heater Division  
ATTN: Technical Service  
800 Interstate Park Drive  
Montgomery, AL 36109  
Phone: 1-800-432-8373

In CANADA:

Rheem Canada, Ltd. / Ltée  
125 Edgeware Road, Unit 1  
Brampton, ON L6Y 0P5  
Phone: 1-800-268-6966.

When contacting the manufacturer, the following information should be made available:

- a. Model and serial numbers of the water heater as shown on the rating plate attached to the jacket of the heater.
- b. Address where the water heater is located and can be seen.
- c. Name and address of the installer and any service agency who performed service on the water heater.
- d. Date of original installation and dates any service work was performed.
- e. Details of the problem as you can best describe them.
- f. List of people, with dates, who have been contacted regarding your problem.

The following Gasket is required for tank cleanout maintenance for all models:

[SP5886](#) Tank Handhole Sealplate Gasket

All other Parts can be ordered by providing the following information:

1. Description of Part(s), such as:
  - Gas Valve
  - Igniter
  - Burner
  - Switch/Sensor
  - Blower Assembly
  - Anode Rods
  - Or other parts as required (see replacement parts section).
2. Quantity of each part required.
3. Complete model number and name of the water heater.
4. Serial Number of water heater.
5. Specify Type of Gas.
6. Address Parts Orders to your distributor or dealer.

**NOTICE:** For installations requiring NSF 5 compliance, order kit AS42690A or B to meet sealing requirements and NSF 5 label.