

C0330, C0530, C0630, C0830, C1030 Service Parts

This part list contains the service parts for the air cooled, water cooled and remote air cooled C0330, C0530, C0630, C0830, C1030 ice machines.

There was a change to panels and the C0530 air cooled condenser in late 2009. Those are designated as B series units.

Top panel trim strips were removed from production in mid 2011.

The C0530 changed to a C series in May 2011. The change was to a new compressor and TXV.

The C0330 changed to a C series in December, 2011, it uses the same compressor as C0530 C.

Models CB0330, CB0530, CB0630, CB0830 and CB1030 include as standard equipment the [KVS](#) and [KSBU-N](#),

To avoid costly and time consuming errors, double check the model and voltage before ordering a part.

Note: These abbreviations are used in this list:

- AC = Air Cooled
- WC = Water Cooled
- RC = Remote Cooled
- HGV = Hot Gas Valve
- TXV = Thermostatic Expansion Valve
- Volt = Voltage
- Sol Vlv = Solenoid Valve
- Hdwe = Hardware

Table of Contents

Cabinet - C0330, C0530, C0630 - A Series	Page 2
Cabinet - C or CB 0330, 0530, 0630 - B Series or C Series	Page 3
Cabinet - C0830, C1030 - A Series	Page 4
Cabinet - C or CB 0830, 1030 - B Series	Page 5
Interior Parts	Page 6
Evaporator Compartment	Page 7
Air Cooled Refrigeration System	Page 8
Air Cooled Mechanical & Electrical - C or CB 0330	Page 9
Air Cooled Mechanical & Electrical - C or CB 0530, 0630, 0830, 1030	Page 10
Water Cooled Refrigeration System	Page 11
Remote Refrigeration System	Page 12
Electrical & Control Box	Page 13
Compressors	Page 14
Compressor Mounting Hardware	Page 14
Crankcase Heaters	Page 14
Remote Condenser, ERC111, ERC211, and ERC311	Page 15

C0330, C0530, C0630, C0830, C1030 Service Parts

Cabinet - C0330, C0530, C0630 - A Series

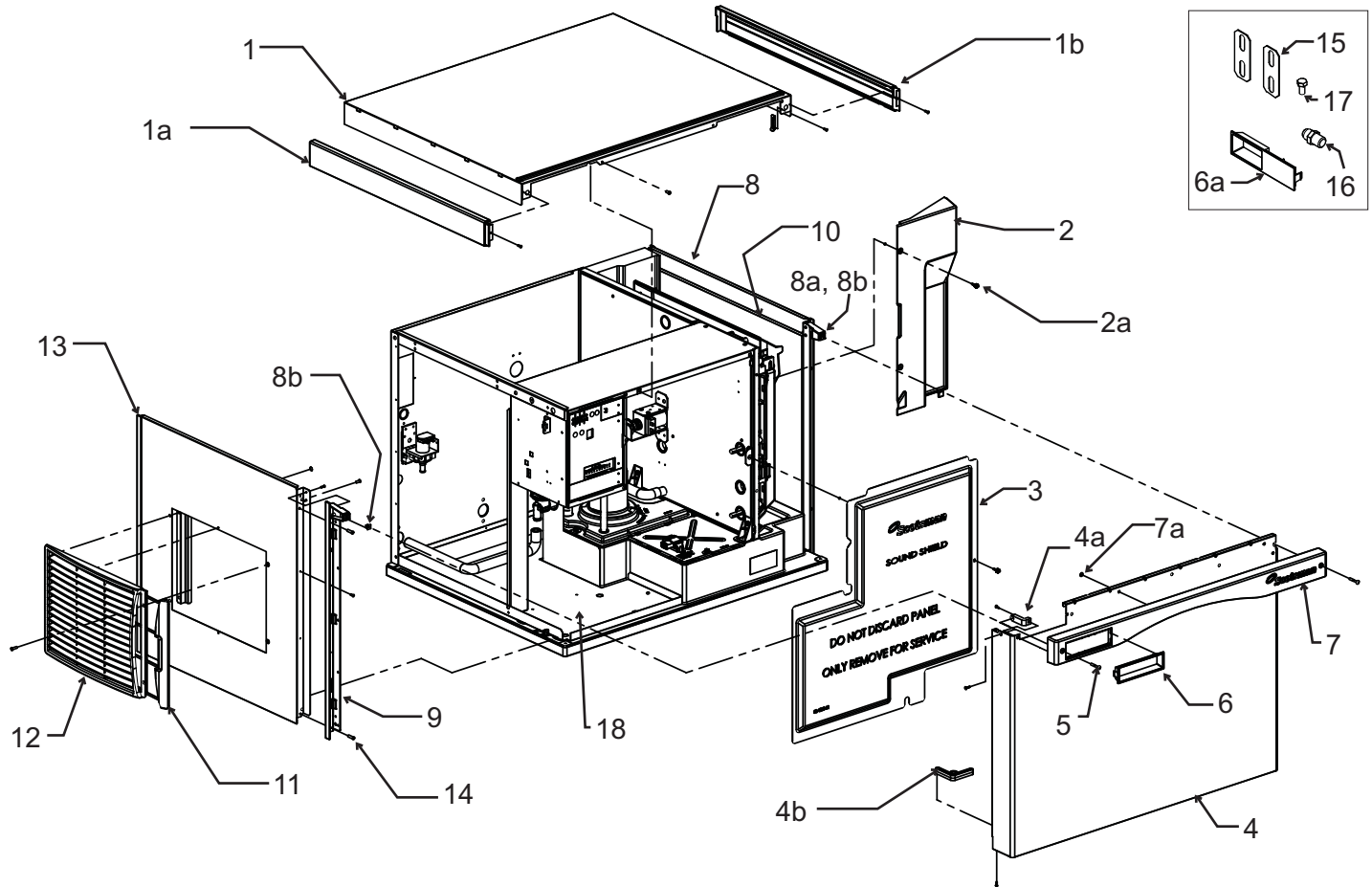

Item Number	Part Number	Description
1*	A38941-022	Top panel, w/trim strips
1a	02-4221-01	Left trim strip
1b	02-4221-02	Right trim strip
2	02-4240-01	Evaporator cover
2a	03-0727-05	Screw
3	02-4218-01	Sound shield - use discontinued late 2008
4*	A38552-022	Front panel assembly, includes trim strip, gussets and labels.
4a	02-4216-01	Top gusset
4b	02-4217-01	Bottom gusset
5	03-1735-03	Screw, front panel
6	02-4284-01	Bezel, full window
6a	02-4284-02	Bezel, partial window
7	02-4214-02	Trim strip
7a	03-1731-02	Push nut
8*	A38553-021	Right side panel assy
8a	02-4215-01	Receptacle
8b	03-3804-01	Screw receptacle
9	02-4067-01	Side panel support for water cooled and remote models
	02-4067-02	Side panel support for air cooled models
10	02-4336-01	Right side panel liner
11	02-4212-01	Air filter
12	02-4224-01	Louver panel
12a	A39222-001	Filter guide
12b	A39238-001	Louver bracket
13*	A38551-021	Left side panel, AC
	A38551-022	Left side panel WC, RC
14	03-1404-12	Screw
15	A30911-015	Machine straps
16	16-0355-00	Inlet water fitting, flare
17	03-1405-15	Screw
18	A38608-001	Compressor deck

*Note: All panels supplied complete as used on unit

C0330, C0530, C0630, C0830, C1030 Service Parts

Cabinet - C or CB 0330, 0530, 0630 - B or C Series

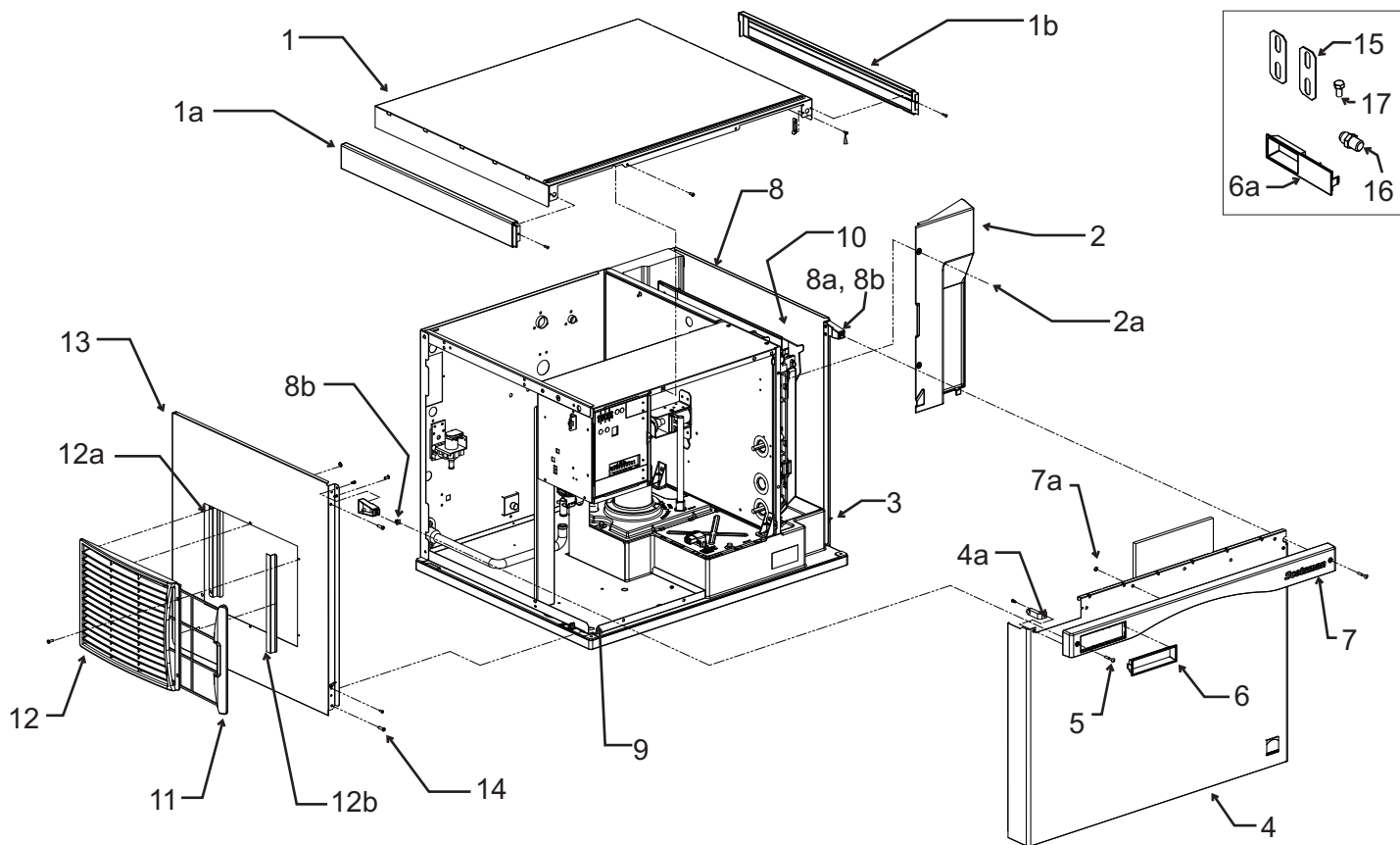

Item Number	Part Number	Description
1	A39579-022	Top panel
1a	02-4221-01	Left trim strip**
1b	02-4221-02	Right trim strip**
2	02-4240-01	Evaporator cover
2a	03-0727-05	Screw
3	A39571-001	Side panel clip
4*	A39578-022	Front panel assembly, includes trim strip, gussets and labels.
4a	02-4216-01	Top gusset
5	03-1735-03	Screw, front panel
6	02-4284-01	Bezel, full window
6a	02-4284-02	Bezel, partial window***
7	02-4214-02	Trim strip
7a	03-1731-02	Push nut
8*	A39581-021	Right side panel assy
8a	02-4215-01	Receptacle
8b	03-3804-01	Screw receptacle
9	A38608-001	Compressor deck
10	02-4336-01	Right side panel liner
11	02-4212-01	Air filter
12	02-4224-01	Louver panel
12a	A39222-001	Filter guide
12b	A39238-001	Louver bracket
13*	A39580-021	Left side panel, AC
	A39580-022	Left side panel WC, RC
14	03-1404-12	Screw
15	A30911-015	Machine straps
16	16-0355-00	Inlet water fitting, flare***
17	03-1405-15	Screw

*Note: All panels supplied complete as used on unit, except top panels do not have trim strips.

** Trim strips discontinued mid 2011

*** Bezel and fitting discontinued from production 2/8/2012.

C0330, C0530, C0630, C0830, C1030 Service Parts

Cabinet - C0830, C1030 - A Series

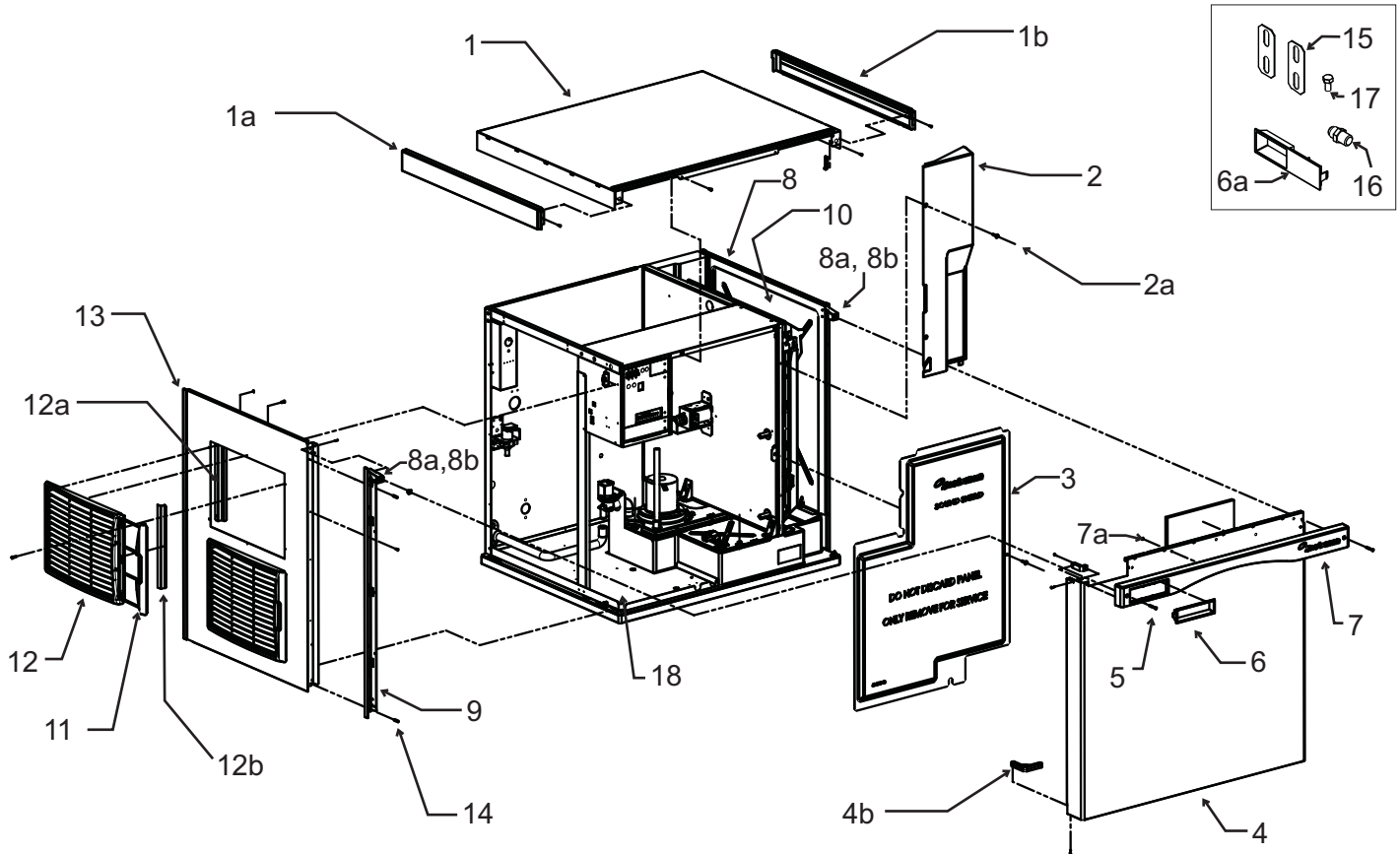

Item Number	Part Number	Description
1*	A38941-022	Top panel, w/trim strips
1a	02-4221-01	Left trim strip
1b	02-4221-02	Right trim strip
2	02-4240-02	Evaporator cover
2a	03-0727-05	Screw
3	02-4218-02	Sound shield - use discontinued late 2008
4*	A38552-023	Front panel assembly, includes trim strip, gussets and labels.
4a	02-4216-01	Top gusset
4b	02-4217-01	Bottom gusset
5	03-1735-03	Screw, front panel
6	02-4284-01	Bezel, full window
6a	02-4284-02	Bezel, partial window
7	02-4214-02	Trim strip
	03-1731-02	Push nut
8*	A38553-022	Right side panel assy
8a	02-4215-01	Receptacle
8b	03-3804-01	Screw receptacle
9	02-4067-03	Side panel support for water cooled and remote models
	02-4067-04	Side panel support for air cooled models
10	02-4336-02	Right side panel liner
11	02-4212-01	Air filter
12	02-4224-01	Louver panel
12a	A39222-001	Filter guide
12b	A39238-001	Louver bracket
13*	A38551-023	Left side panel, AC
	A38551-024	Left side panel WC, RC
14	03-1404-12	Screw
15	A30911-015	Machine straps
16	16-0355-00	Inlet water fitting, flare
17	03-1405-15	Screw
18	A38611-001	Compressor deck

*Note: All panels supplied complete as used on unit.

C0330, C0530, C0630, C0830, C1030 Service Parts

Cabinet - C or CB 0830, 1030 - B Series

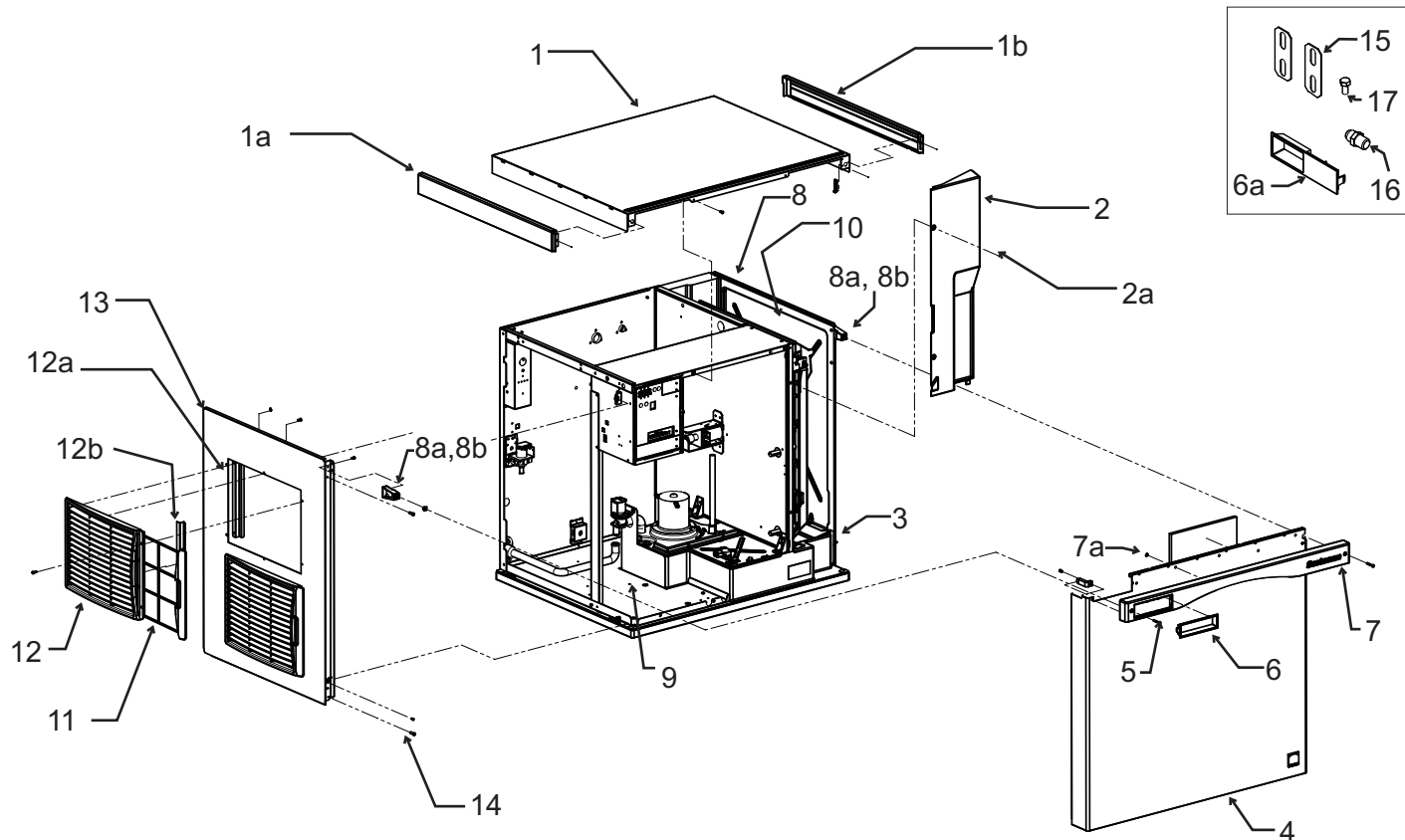

Item Number	Part Number	Description
1	A39579-022	Top panel
1a	02-4221-01	Left trim strip**
1b	02-4221-02	Right trim strip**
2	02-4240-02	Evaporator cover
2a	03-0727-05	Screw
3	A39571-001	Side panel clip
4*	A39578-023	Front panel assembly, includes trim strip, gussets and labels.
4a	02-4216-01	Top gusset
5	03-1735-03	Screw, front panel
6	02-4284-01	Bezel, full window
6a	02-4284-02	Bezel, partial window***
7	02-4214-02	Trim strip
	03-1731-02	Push nut
8*	A39581-022	Right side panel assy
8a	02-4215-01	Receptacle
8b	03-3804-01	Screw receptacle
9	A38611-001	Compressor deck
10	02-4336-02	Right side panel liner
11	02-4212-01	Air filter
12	02-4224-01	Louver panel
12a	A39222-001	Filter guide
12b	A39238-001	Louver bracket
13*	A39580-023	Left side panel, AC
	A39580-024	Left side panel WC, RC
14	03-1404-12	Screw
15	A30911-015	Machine straps
16	16-0355-00	Inlet water fitting, flare***
17	03-1405-15	Screw

*Note: All panels supplied complete as used on unit, except top panels do not have trim strips.

** Trim strips discontinued mid 2011

*** Bezel and fitting discontinued from production 2/8/2012.

C0330, C0530, C0630, C0830, C1030 Service Parts

Interior Parts

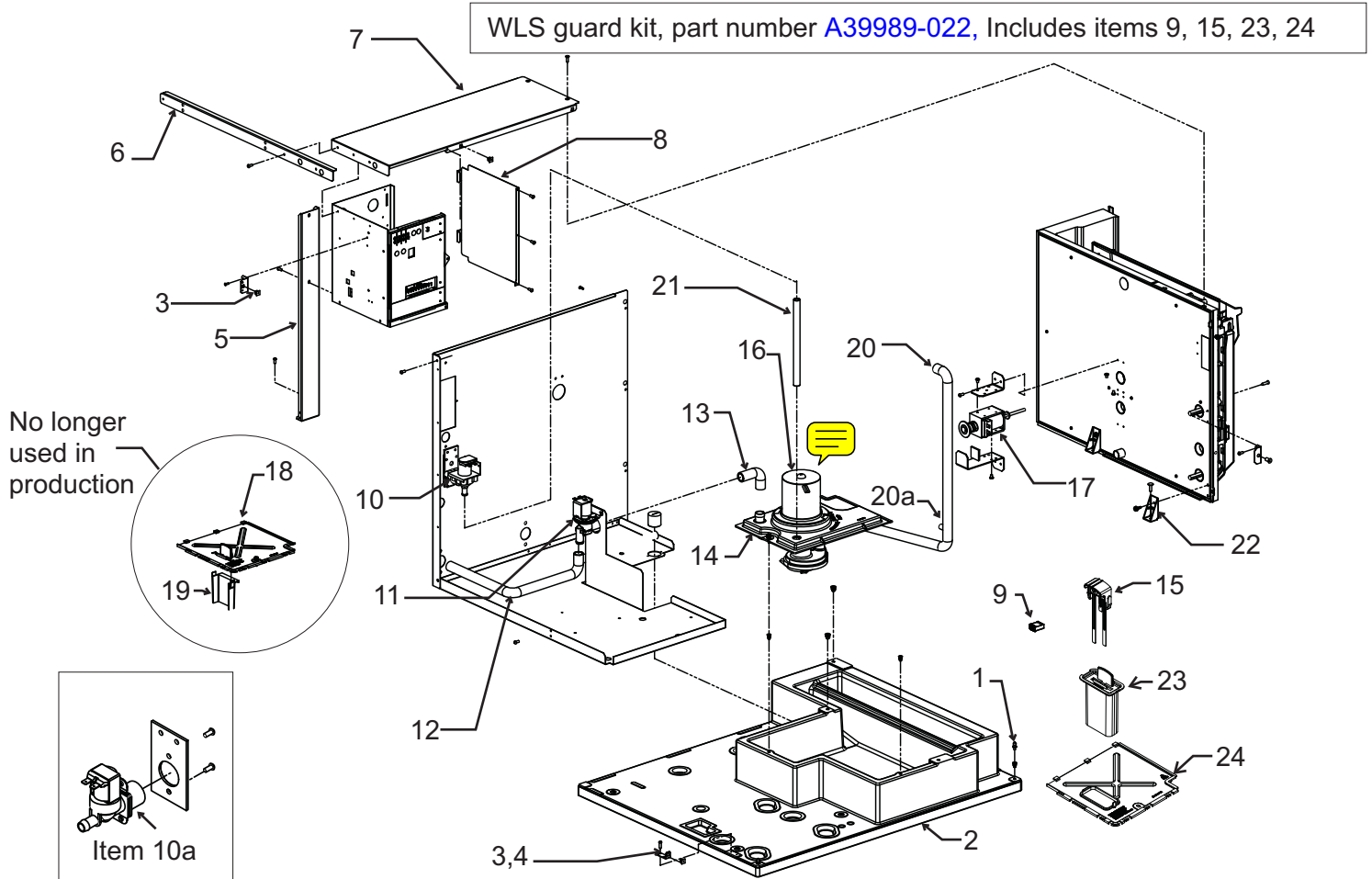

Item Number	Part Number	Description
1	15-0411-00	Strike (A series)
2	A38589-002	Base, insulated
3	03-3804-01	Receptacle
4	A38732-001	Side panel mount
5	A38607-001	Strut, C or CB 0330-630
	A38629-001	Strut, C or CB 0830, C1030
6	A38582-001	Brace
7	A38539-002	Control box top
8	A38537-001	Control box side
9	see page 14 for WLS harness	
10	12-2922-01	Inlet water sol vlv, 115 volt
	12-2922-02	Inlet water sol vlv, 230 volt
	12-2912-01	Water valve rebuild kit
10a	11-0568-02	Inlet water sol vlv, CE mod
11	11-0564-01	Purge valve, 115 volt
	11-0564-02	Purge valve, 230 volt
12	A38860-002	Drain tube
13	A38860-001	Drain hose
14	02-4164-01	Water pump bracket
15	A39030-021	Water level sensor

16	see table	Water pumps	
Pumps	115	208-230/60	208-230/50
C or CB 0330, 0530	12-2919-21	12-2919-22	12-2919-26
C or CB 0630	-	12-2919-22	12-2919-26
C or CB 0830, 1030	-	12-2920-23	12-2920-25

17	see table	Harvest assist solenoid	
Hvst. solenoids	115	208-230	
C or CB 0330, C0530	12-3035-21	12-3035-22	
C or CB 0630	-	12-3035-22	
C or CB 0830, 1030	-	12-3036-22	

18	02-4166-01	Reservoir cover (prior)
19	02-4332-01	Sensor cover (prior)
20	02-4154-03	Pump hose, C/CB0830-1030
	02-4154-02	Pump hose, C/CB0530-0630
	02-4154-01	Pump hose, C0330
20a	11-0515-21	Temp sensor set
21	13-0674-02	Fill hose order by ft
	15-0821-01	Fill hose, -6 CE models
22	02-4152-01	Gusset
23	02-4646-01	WLS guard, use/w item 24
24	02-4647-01	Sump cover, use/w item 23

C0330, C0530, C0630, C0830, C1030 Service Parts

Evaporator Compartment

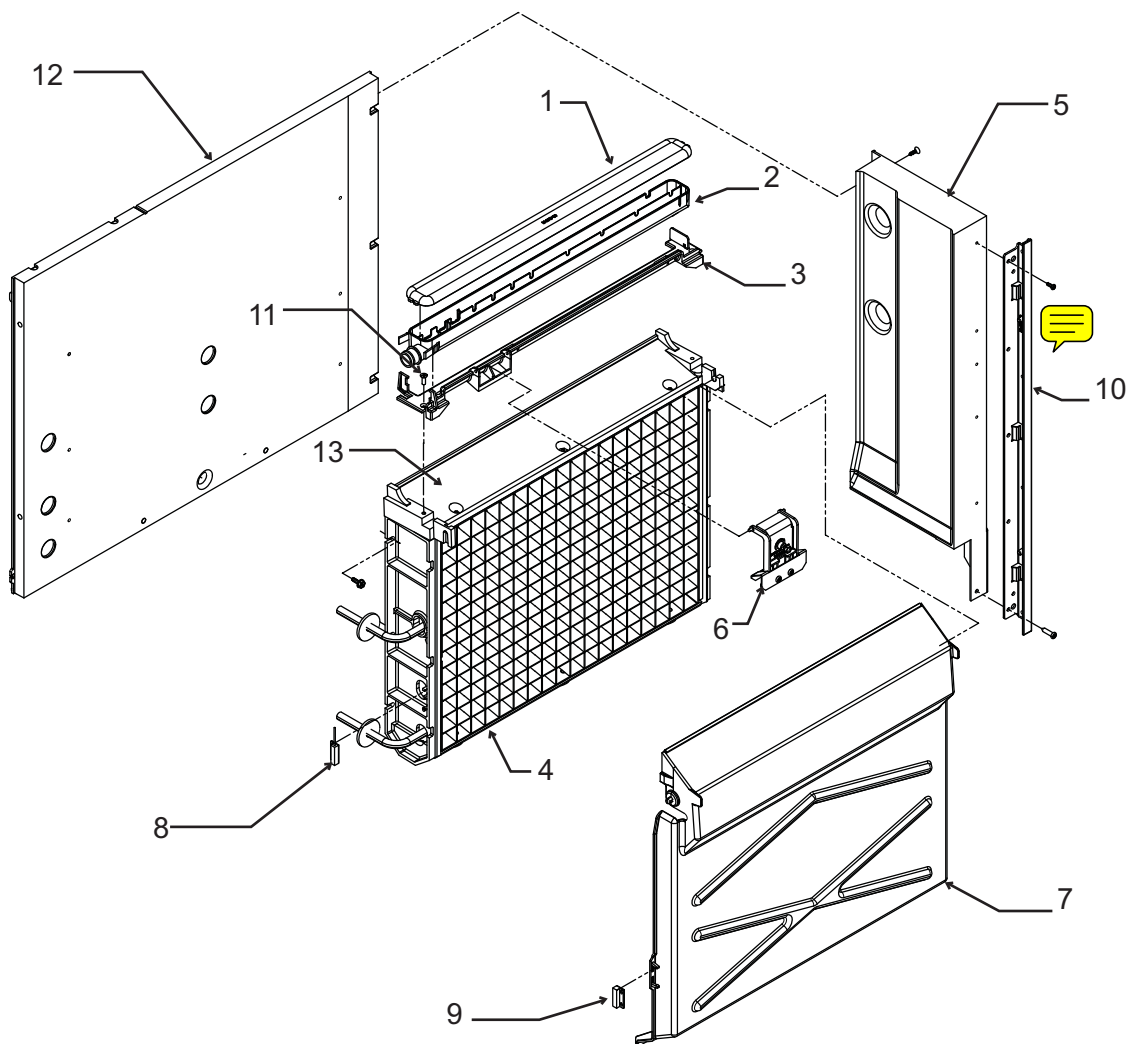

Item Number	Part Number	Description
1	02-4065-01	Water distributor cover
2	02-4064-01	Water distributor
3	02-4205-01	Mounting bracket
4	see table	Evaporator
5	A38596-001	Back wall, C or CB 0330, 0530, 0630
6	A39031-021	Ice thickness sensor
7	02-4100-31	Curtain, C/CB 0330
	02-4100-32	Curtain, C/CB 0530, 0630
	02-4611-21	Curtain, C/CB 0830, 1030
8	11-0563-01	Curtain switch
9	11-0563-02	Curtain switch magnet
10	02-4067-01	Side panel support C0330, 0530, 0630 A series
	02-4067-03	Side panel support C0830, 1030 A series only
11	03-1418-30	Mounting screw
12	13-0943-01	Gasket tape
13	02-4156-21	Spillway replacement kit

Note: Item 7 includes item 9, shipped loose.

C0330, C0530, C0630, C0830, C1030 Service Parts

Air Cooled Refrigeration System

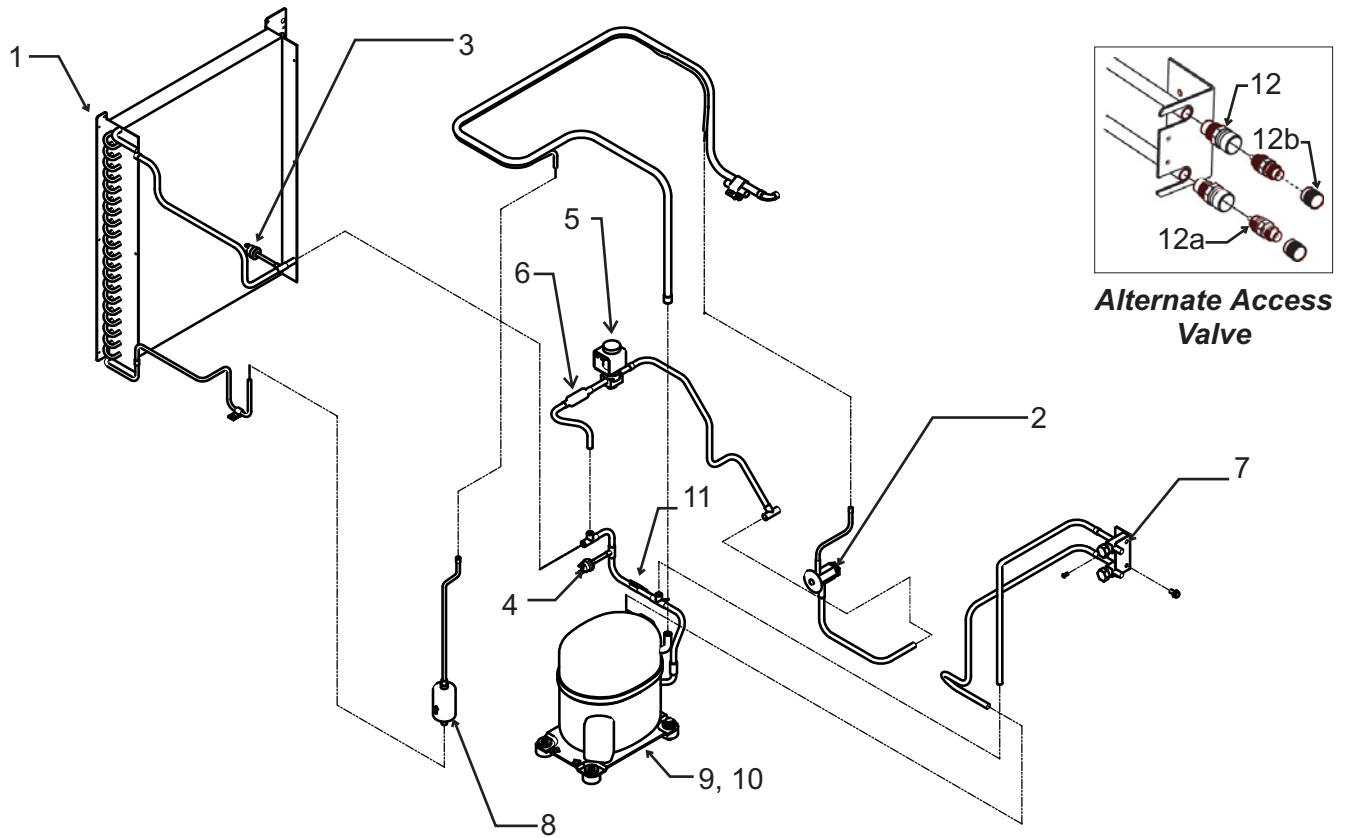

Item Number	Part Number	Description	Item Number	Part Number	Description
1	18-8890-01	Condenser, AC, C/CB 0330	5	11-0493-02	Hot gas valve, 115 volt
	18-8920-01	Cond, AC, C0530 - A series		12-2719-21	115 volt coil
	18-8935-01	Cond, AC, C/CB 0530 - B or C series		11-0493-01	Hot gas valve, 230 volt
	18-8896-01	Condenser, AC, C/CB 0630		12-2719-22	230 volt coil
	18-8895-01	Condenser, AC, C/CB 0830, 1030		12-2733-30	HGV rebuild kit
2	16-1182-02	TXV, C0530 A or B Series	6	16-1063-01	Strainer
	16-1184-01	TXV, C/CB0530 C series	7	16-0832-20	Access valve
	16-1182-01	TXV, C/CB0630		16-0832-03	Port cap
	16-1183-02	TXV, C/CB0330		16-0832-02	Stem cap
	16-1142-01	TXV, C/CB 0830, 1030	8	02-3319-01	Dryer C/CB 0330 thru 0630
	19-0599-06	Insulation, TXV		02-3319-02	Dryer, C/CB 0830 & 1030
3	11-0566-21	Fan cycle pressure sw.	9	see page 12	Compressors
4	11-0501-05	Hi pressure cut out, C or CB 0330, 0530 and 0630	10	see page 12	Compressor mounting hdw
			11	11-0515-21	Temp sensor set
				Use of alternate access valve began 4-08	
			12	16-1137-01	Valve body
			12a	16-1139-01	Core
			12b	16-1140-01	Cap

C0330, C0530, C0630, C0830, C1030 Service Parts

Air Cooled Mechanical & Electrical - C or CB 0330

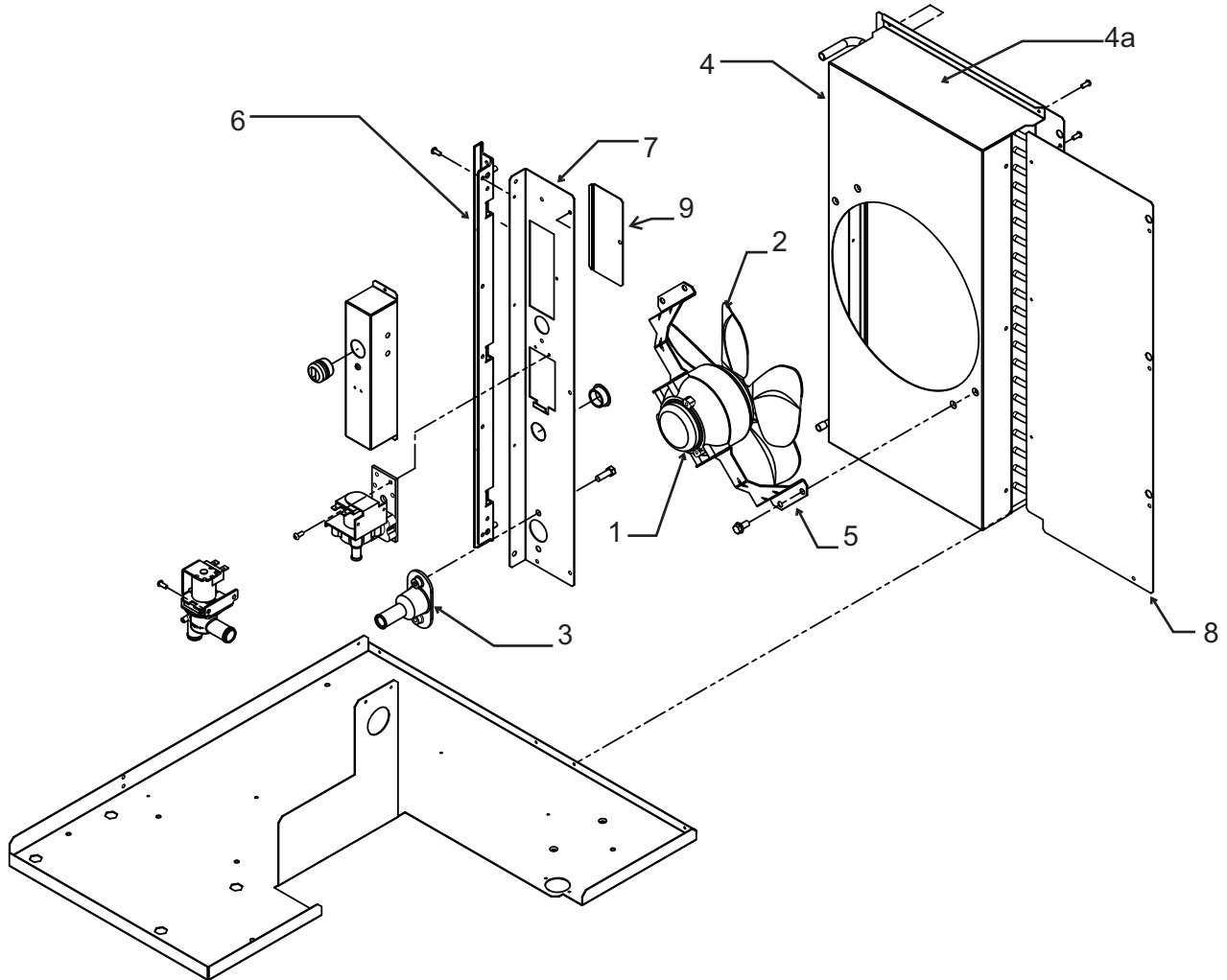

Item Number	Part Number	Description
1	12-1681-23	Fan motor, C or CB0330, 115 volt
	12-1681-04	Fan motor, C0330, 230 volt
2	18-8836-01	Fan blade, C or CB0330
3	02-3692-21	Drain adapter - also for WC and RC
4	A38841-001	Fan shroud, C0330 A Series
	A39350-001	Fan shroud, C or CB 0330 B or C Series
4a	A39593-001	Fan shroud top, B or C series
5	A38480-001	Fan motor bracket, C or CB 0330
6	02-4067-02	Side panel support, C or CB 0330, 0530, 0630
7	A38791-001	Utility channel, AC A series
	A39586-001	Utility channel, AC B or C series
8	A39606-001	Back panel, B or C series
9	A38548-002	Junction box cover

C0330, C0530, C0630, C0830, C1030 Service Parts

Air Cooled Mechanical & Electrical - C or CB 0530, 0630, 0830, 1030

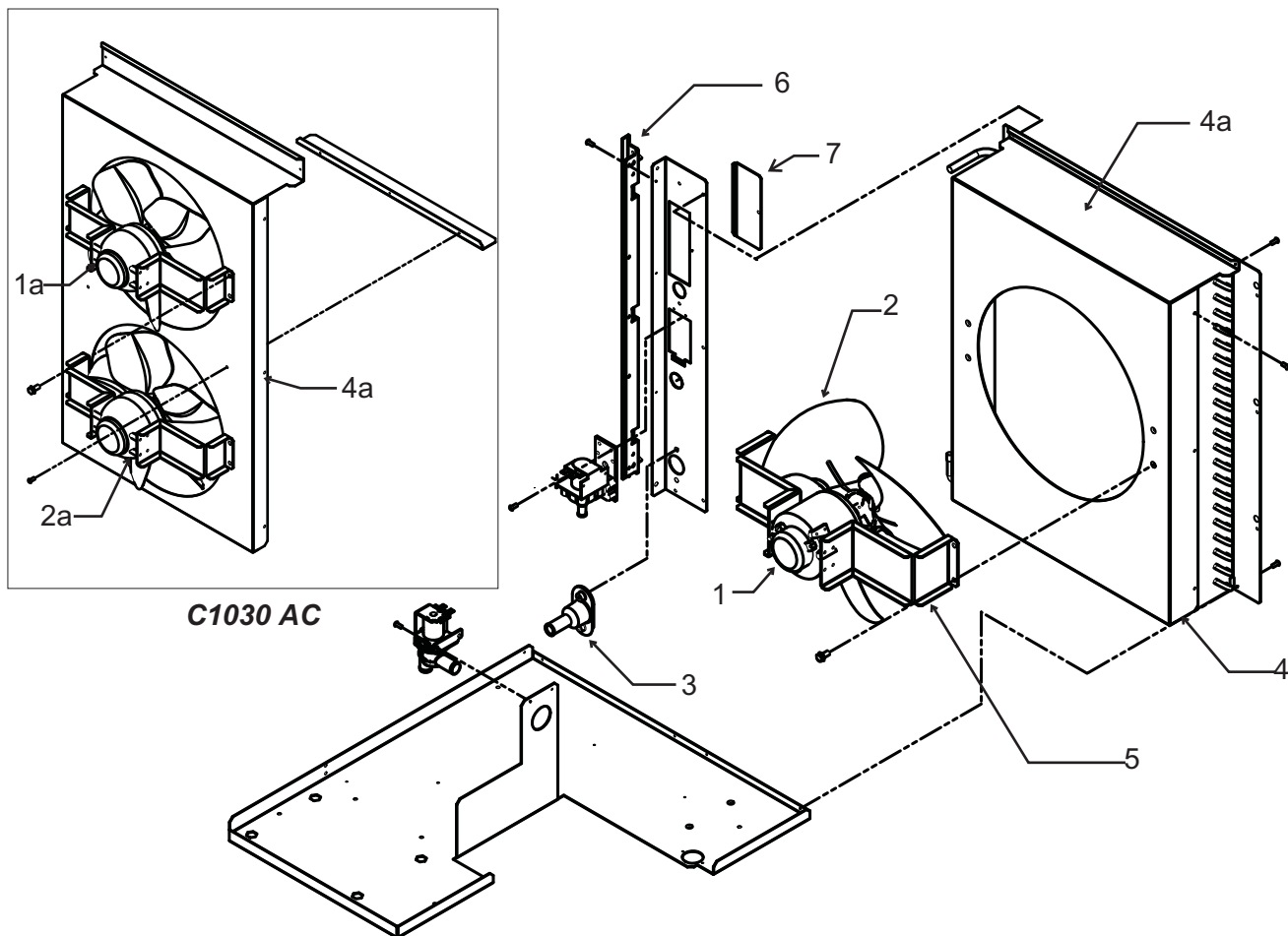

Item	Description	C/CB 0530 115 volt	C/CB 530 - 230 volt or C/CB 630 or C/CB 830	C/CB 1030 60 Hz	C/CB1030 50 Hz	C0530, C0630	C/CB 0530, 0630	C/CB 0830	C1030	C/CB 1030
	Series	all	all*	all	all	A	B or 0530 C	B	A	B
1	Fan motor	18-8926-01	18-8927-01	18-8899-01	18-8899-06	-	-	-	-	-
2	Fan blade	18-8882-01		18-8900-01		-	-	-	-	-
3	Drain adapter	02-3692-21								
4	Fan shroud	-	A38868-001 *C0830 A series only	-	-	A38623-001	A39607-001	A39603-001	A38624-001	A39609-001
4a	Shroud top	-	-	-	-	-	A39608-001	A39601-001	-	A39610-001
5	Fan motor bracket	A38554-001		A38655-001		-	-	-	-	-

6 Side panel support, A series only.

C0330, C0530 and C0630 [02-4067-02](#)

C0830, C1030 [02-4067-04](#)

7 [A38548-002](#) J box cover

C0330, C0530, C0630, C0830, C1030 Service Parts

Water Cooled Refrigeration System

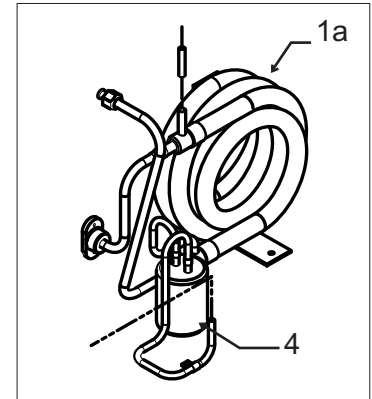
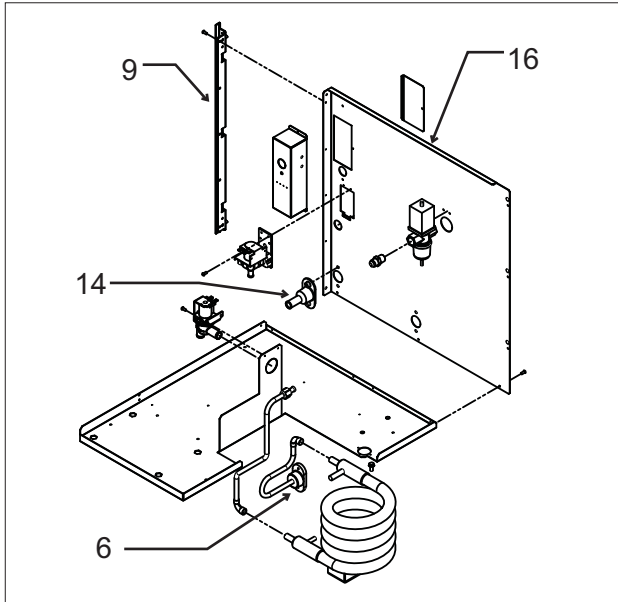

C0830, C1030

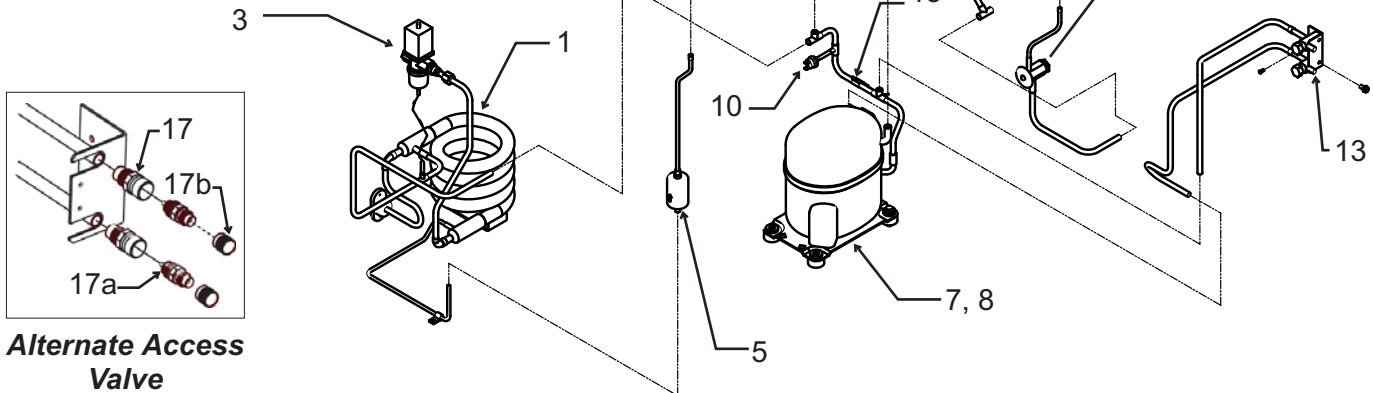

Alternate Access Valve

Item Number	Part Number	Description
1	18-8871-21	Condenser, WC, C0330, C0530, C0630, C0830
1a	18-8893-21	Condenser, WC, C1030
2	16-1182-02	TXV, C0530 A or B series
	16-1184-01	TXV, C 0530 C series
	16-1182-01	TXV, C 0630
	16-1183-02	TXV, C/0330
	16-1142-01	TXV, C0830, C1030
	19-0599-06	Insulation TXV
3	11-0478-01	Water regulating valve
4	16-0874-01	Receiver, C0830, C1030
5	02-3319-01	Dryer, C0330 thru C0630
	02-3319-02	Dryer, C0830 - C1030
6	A31828-002	Condenser drain
7	see page 12	Compressors
8	see page 12	Compressor mounting hdw
9	02-4067-01	Side panel support, C0330, C0530, C0630 - A series only
10	11-0501-21	High pressure cut out
11	11-0493-02	Hot gas valve, 115 volt
	11-0493-01	Hot gas valve, 230 volt
	12-2719-22	230 volt coil
	12-2733-30	HGV rebuild kit
12	16-1063-01	Strainer
13	16-0832-20	Access valve
	16-0832-03	Port cap
	16-0832-02	Stem cap
14	02-3692-21	Drain adapter
15	11-0515-21	Temp sensor set
16	A38634-001	Back pnl, WC - A Series 23"
	A38625-001	Back pnl, WC - A Series 29"
	A39561-001	Bck pnl, WC - B/C series 23"
	A39573-001	Back pnl, WC - B Series 29"
17	16-1137-01	Valve body
17a	16-1139-01	Core
17b	16-1140-01	Cap

C0330, C0530, C0630, C0830, C1030 Service Parts

Remote Refrigeration System

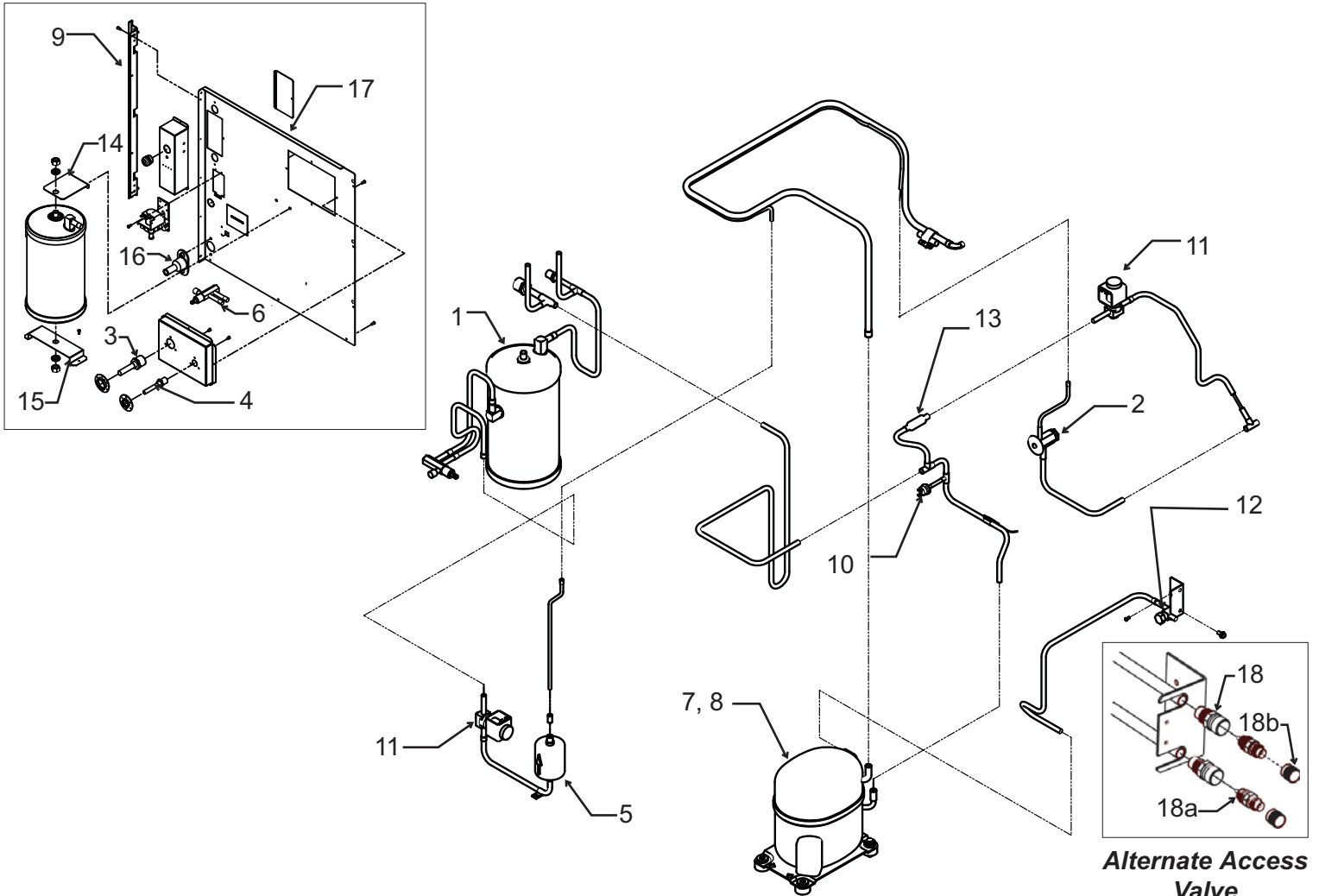

Item Number	Part Number	Description
1	16-1176-01	Receiver, C0530, C0630
	16-1175-01	Receiver, C0830, C1030
2	16-1182-02	TXV, C0530 A or B series
	16-1184-01	TXV, C0530 C series
	16-1182-01	TXV, C0630
	16-1142-01	TXV, C0830, C1030
	19-0599-06	Insulation, TXV
3	16-0850-01	Discharge quick connect
4	16-0850-03	Liquid quick connect
5	02-3319-02	Drier
6	16-1030-01	Liquid line access valve
7	see page 12	Compressors
8	see page 12	Compressor mounting hwd
8a	see page 12	Crankcase heater
9	02-4067-01	Side panel support, C0330, C0530, C0630 - A series
	02-4067-04	Side panel support, C0830, C1030 - A series
10	11-0501-22	High pressure cut out
11	11-0493-02	Liquid line vlv or HGV, 115 v
	11-0493-01	Liquid line vlv or HGV, 230 v
12	16-0832-20	Access valve
	16-0832-03	Port cap
	16-0832-02	Stem cap
13	16-1063-01	Strainer
14	A37211-001	Top receiver bracket
15	A37212-001	Bottom receiver bracket
16	02-3692-21	Drain adapter
17	A38664-001	Back pnl, RC - A series 23"
	A38665-001	Back pnl, RC - A series 29"
	A39561-001	Bck pnl, RC - B/C series 23"
	A39573-001	Back pnl, RC - B Series 29"
Use of alternate access valve began 4-08		
18	16-1137-01	Valve body
18a	16-1139-01	Core
18b	16-1140-01	Cap

C0330, C0530, C0630, C0830, C1030 Service Parts

Electrical & Control Box

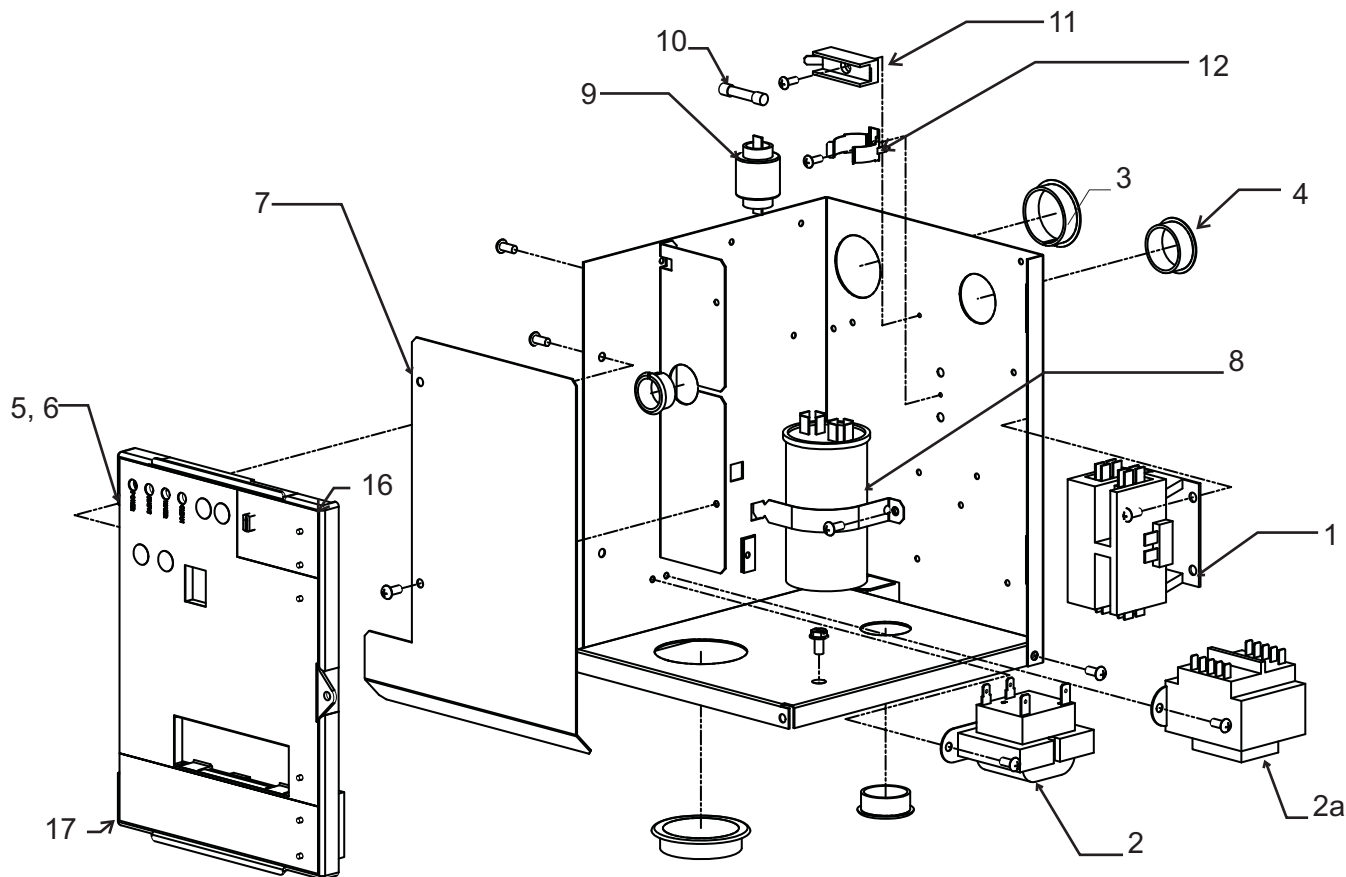

Item Number	Part Number	Description
1	12-2469-03	Contactors, 115 volt
	12-2469-02	Contactors, 230, single ph
	12-2533-02	Contactors, three phase
2	12-2924-01	Transformer, 115 volt
	12-2924-02	Transformer, 230 volt
2a	12-2639-01	Transformer, 50 Hz
3	12-1213-11	Snap bushing
4	12-1213-15	Snap bushing
5	11-0550-28	Service controller, fits all Prodigy cubers
	11-0550-27	Service controller, for all but C0530C
6	02-4076-01	Control box door
	02-4189-01	Overlay label
7	A39216-001	Barrier
8		see next page Run capacitor
9		see next page PTCR -
10	12-2686-01	Fuse, 50 Hz only
11	12-2687-01	Fuse holder
12	18-8835-02	Bracket
Wiring Harnesses (not illustrated)		
13	12-2931-01	Power harness, A & W
	12-2931-02	Power harness, Remote
Power harness connects to J1 on controller		
14	12-2932-01	Hi voltage harness, A & W
	12-2933-01	Hi voltage harness, Rem
	12-2971-01	Hi voltage, 50 Hz A & W
Hi voltage harness has the 8 pin connector		
15	12-2928-01	WLS harness
16	KVS	Vari-smart ice level control
17	KSBU-N	Smart-Board

Items 16 and 17 standard on CB models.

C0330, C0530, C0630, C0830, C1030 Service Parts

Compressors

Model	Series	Electrical	Compressor	Overload	Run Capacitor	PTCR
C/CB 0330-1	A or B	115/60/1	18-8897-21	18-8897-23*	18-1902-53*	18-8835-01*
C0330-6	A or B	230/50	18-8897-26	18-8897-28*	18-1902-57*	18-8835-01*
C0330-32	A or B	208-230/60/1	18-8897-22	18-8897-27*	18-1902-57*	18-8835-01*
C/CB 0330-1	C	115/60/1	18-8948-21	18-8948-50*	18-1902-64*	18-8835-01*
C0330-6	C	230/50	18-8948-22	18-8948-51*	18-1902-65*	18-8835-01*
C0330-32	C	208-230/60/1	18-8948-23	18-8948-51*	18-1902-30*	18-8835-01*
C0530-1	A or B	115/60/1	18-8921-21	18-8921-23*	18-1902-45*	18-8835-01*
C0530-6	A or B	230/50	18-8921-26	18-8774-27*	18-1902-68*	18-8835-01*
C0530-32	A or B	208-230/60/1	18-8921-22	18-8774-28*	18-1902-52*	18-8835-01*
C/CB 0530-1	C	115/60/1	18-8948-21	18-8948-50*	18-1902-64*	18-8835-01*
C0530-6	C	230/50	18-8948-22	18-8948-51*	18-1902-65*	18-8835-01*
C0530-32	C	208-230/60/1	18-8948-23	18-8948-51*	18-1902-30*	18-8835-01*
C/CB 0630-32	A or B	208-230/60/1	18-8922-22	18-8922-27*	18-1902-57	18-8835-01
C0630-6	A or B	230/50	18-8922-26	internal	18-1902-71	18-8835-01
C/CB 0830-32	A or B	208-230/60/1	18-8813-23	internal	18-1902-53*	18-8835-01*
C0830-6	A or B	230/50	18-8813-27	internal	18-1902-69	18-8835-01
C0830-3	A or B	208-230/60/3	18-8813-25	internal	-	-
C/CB 1030-32	A or B	208-230/60/1	18-8726-23	internal	18-1902-53*	18-8835-01
C1030-6	A or B	230/50	18-8726-27	internal	18-1902-69	18-8835-01
C1030-3	A or B	208-230/60/3	18-8726-25	internal	-	-

Compressor Mounting Hardware

Model	Series	Bolt	Washer	Grommet	Sleeve
C/CB 0330	A or B	03-1405-20	03-1407-07	18-4700-28	18-0108-41
C0530	A or B	03-1405-20	03-1407-07	18-4700-28	18-0108-41
C/CB 0330 or 0530	C	03-1405-20	03-1407-07	18-2200-28	18-2200-27
C/CB 0630	A or B	03-1405-20	03-1407-07	18-4700-28	18-0108-41
C/CB 0830 or 1030	A or B	03-1405-20	03-1407-07	18-2300-27	18-2300-26

Crankcase Heaters

Model	Crankcase heater
C0530R A or B Series	12-2942-01
C0530R C Series	12-3043-01
C0630R	12-2942-02
C0830R or C1030R	18-2308-01 internal 12-3043-03* external

* Replacement compressors include selected components and a filter dryer. They may also include other components used only on other models. CS type compressors include fittings to adapt to prior tubing sizes.

C0330, C0530, C0630, C0830, C1030 Service Parts

Remote Condenser, ERC111, ERC211, and ERC311

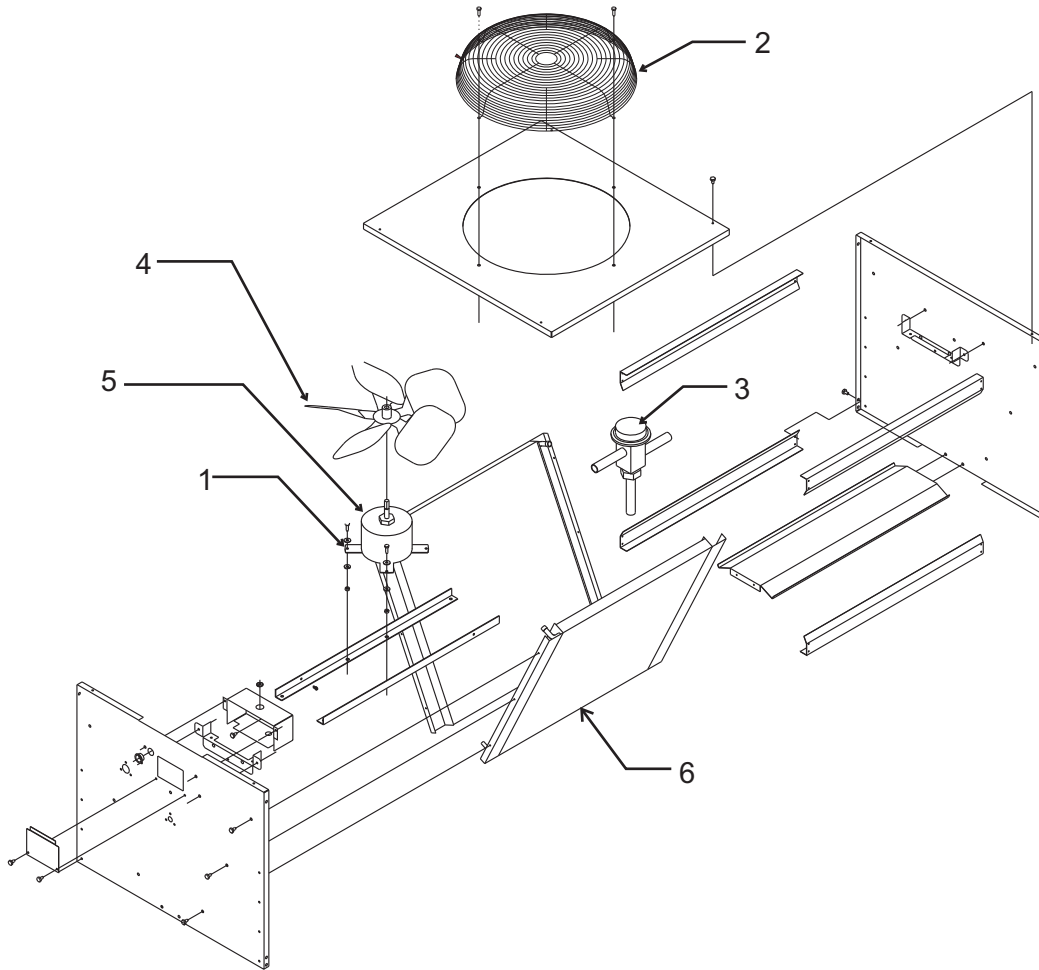

Item Number	Part Number	Description
1	03-1405-08	Screw
2	02-3575-01	Fan guard
3	11-0422-22	Headmaster
4	18-8816-01	Fan blade
5	12-2651-01	Fan motor - 230 volt (ERC311)
	12-2651-02	Fan motor - 115 volt (ERC111 and ERC211)
6	18-8815-01	Coil, ERC111
	18-8827-01	Coil, ERC311

Not Shown:

- [A37169-001](#) Leg
- [A37170-001](#) Leg brace
- [03-1645-01](#) Screw for legs
- [16-0850-01](#) Quick connect, discharge
- [16-0850-03](#) Quick connect, liquid