

CME1356 and CME1656 Service Parts

This parts list contains the part numbers and description of the replacement parts available for these two models.

They have been manufactured in both 50 Hz and 60 Hz models, plus there have been model series changes from A to C to D to E to F to H.

To avoid costly and time consuming errors, double check the model and voltage before ordering a part.

Table of Contents

Cabinet page 2

Water System page 3

Air Cooled Refrigeration System page 4

Water Cooled Refrigeration System page 5

Electrical page 6

BH900 page 7

BH1356 page 8

Kit Parts page 9

Wiring Diagrams page 10

CME1356 and CME1656 Service Parts Cabinet

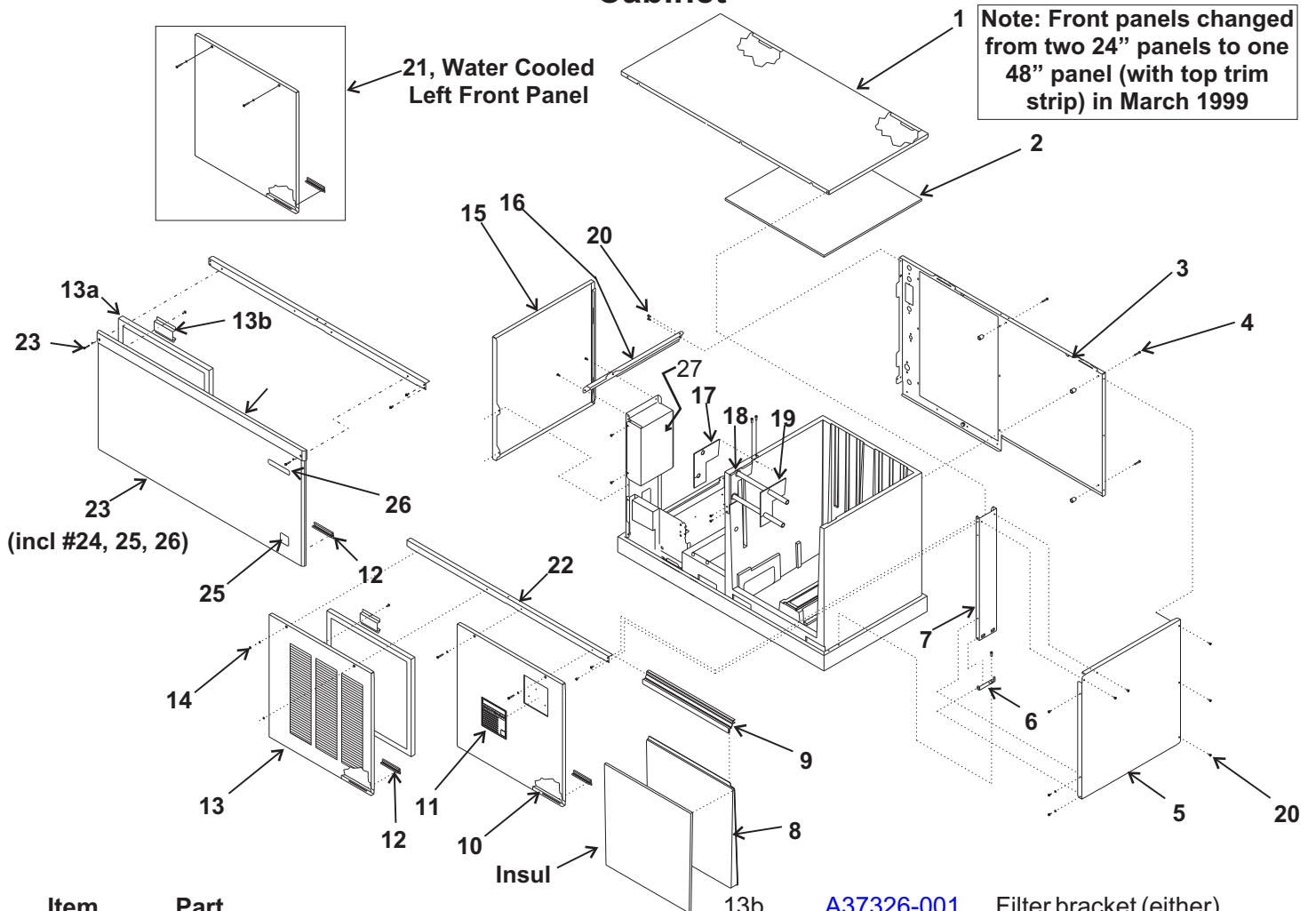

Item Number	Part Number	Description	Part Number	Description
1	A37202-015	Top panel, Grey	13b	A37326-001 Filter bracket (either)
	A37202-002	Top panel, SS	14	03-1728-01 Front panel screw
	02-3823-21	Top panel, plastic for C - H series. Will not fit A or B series.	15	A37198-015 Left side pnl, no louvers grey
2	02-3686-01	Insulation		A37198-002 Left side panel, no louvers SS
3	A37197-001	Back pnl - for wc A & B		A38025-001 Left side panel, louvered for Air cooled E & F & H series
	A37196-001	Back pnl - for ac A & B	16	A37193-001 Left side channel
	A37670-001	Back pnl for AC C - H	17	02-3696-03 Left side grommet
	A37669-001	Back pnl for WC C - H	18	A37216-001 Bracket
4	03-1404-37	Screw	19	02-3696-02 Right grommet
5	A37199-015	Rt side panel, grey, A & B	20	03-1531-01 Screw
	A37199-002	Rt side panel, SS, A & B	21	A37201-015 24" Left front panel, grey
	A37668-001	Rt side panel, C - H series		A37201-002 24" Left front panel, SS
6	A37194-001	Right bottom channel	22	A37195-001 Top front channel
7	A37213-001	Right side support	23	A37489-031 SS 48" panel w/o louvers
8	02-3702-21	Evaporator cover, incl insul		A37489-002 Grey 48" panel w/o louvers
9	02-3701-01	Cover retainer		A37489-033 SS 48" panel with louvers
10	A37200-015	24" Right front panel, grey		A37489-004 Grey 48" panel with louvers
	A37200-002	24" Right front panel, SS	23a	03-1735-01 Screw
11	15-0808-01	Emblem	24	02-3794-02 Trim strip
12	02-3699-01	Panel support clip		03-1731-02 Push nut
13	A37262-015	24" Left front panel AC - grey	25	15-0792-01 CM3 emblem
	A37262-002	24" Left front panel, AC -SS	26	15-0711-02 Scotsman emblem
13a	02-3485-01	Air filter, for front or left side		03-0271-00 Nut for emblems #25 & 26
			27	A37214-001 Control box cover

CME1356 and CME1656 Service Parts

Water System

Item Number	Part Number	Description
1	02-3613-01	Elbow
2	02-3520-01	Elbow, rt. 1356
3	13-0617-48	O-ring
4	02-3518-01	Manifold
5	02-3519-01	Manifold right, 1656
6	13-0840-01	Plug
7	02-2527-01	Water distributor
8	A37315-021	Evaporator
9	02-3725-01	Hose clamp
10	02-3672-01	Right trough, 1656 only
11	02-3672-02	Left trough
12	A37337-001	Evap support
13	11-0540-21	Ice sensor (set)
14	02-3337-02	Ice deflector
15	02-3706-01	Upper inner splash panel

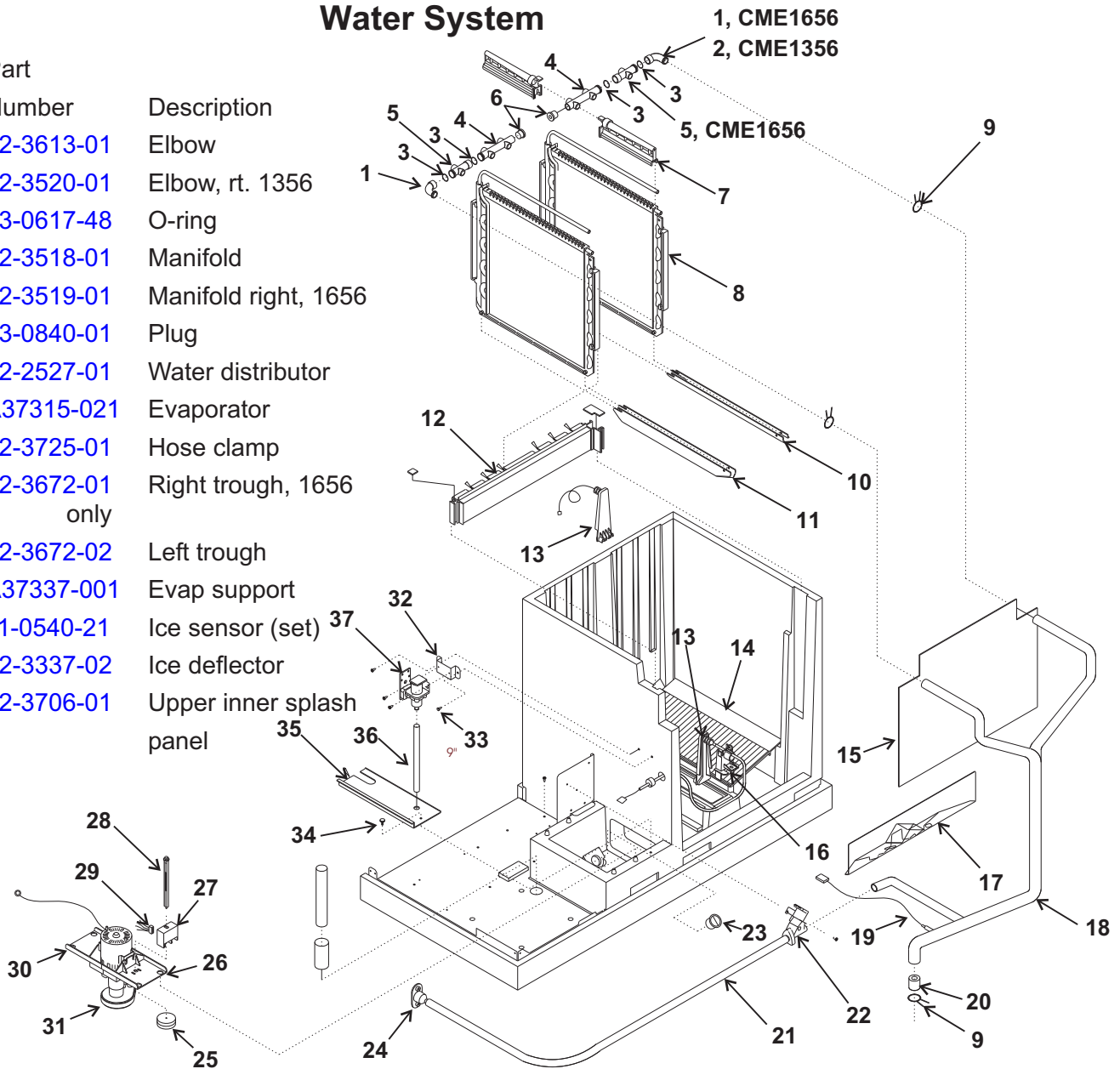

16	02-3689-01	Ice sensor holder	26	02-3388-04	Pump bracket
17	02-3680-01	Lower inner splash panel	27	11-0539-51	Water level sensor
18	02-3660-02	CME1356 water hose	28	02-3383-04	Float stem, tan for 1356
	02-3660-01	CME1656 water hose	29	02-3383-05	Float stem, brown for 1656
19	11-0515-21	Temp sensor set	30	12-2665-01	Harness for water sensor
20	02-3614-01	Flow restrictor, 1356 only no longer used	31	02-3388-05	Pump bracket
21	13-0674-06	Drain hose, order 2 units	32	12-2582-21	Water pump
22	11-0514-01	Purge valve	33	A37204-001	Bracket
	11-0514-21	Coil only	34	03-1404-18	Screw
23	02-3703-01	Drain plug	35	03-1691-01	Nylon screw
24	02-3692-21	Drain fitting	36	02-3534-01	Reservoir cover
25	02-3341-01	Float	37	13-0674-02	Tube, order 1 unit
				12-2666-01	Inlet water valve
				16-0355-00	Coupling

CME1356 and CME1656 Service Parts

Air Cooled Refrigeration

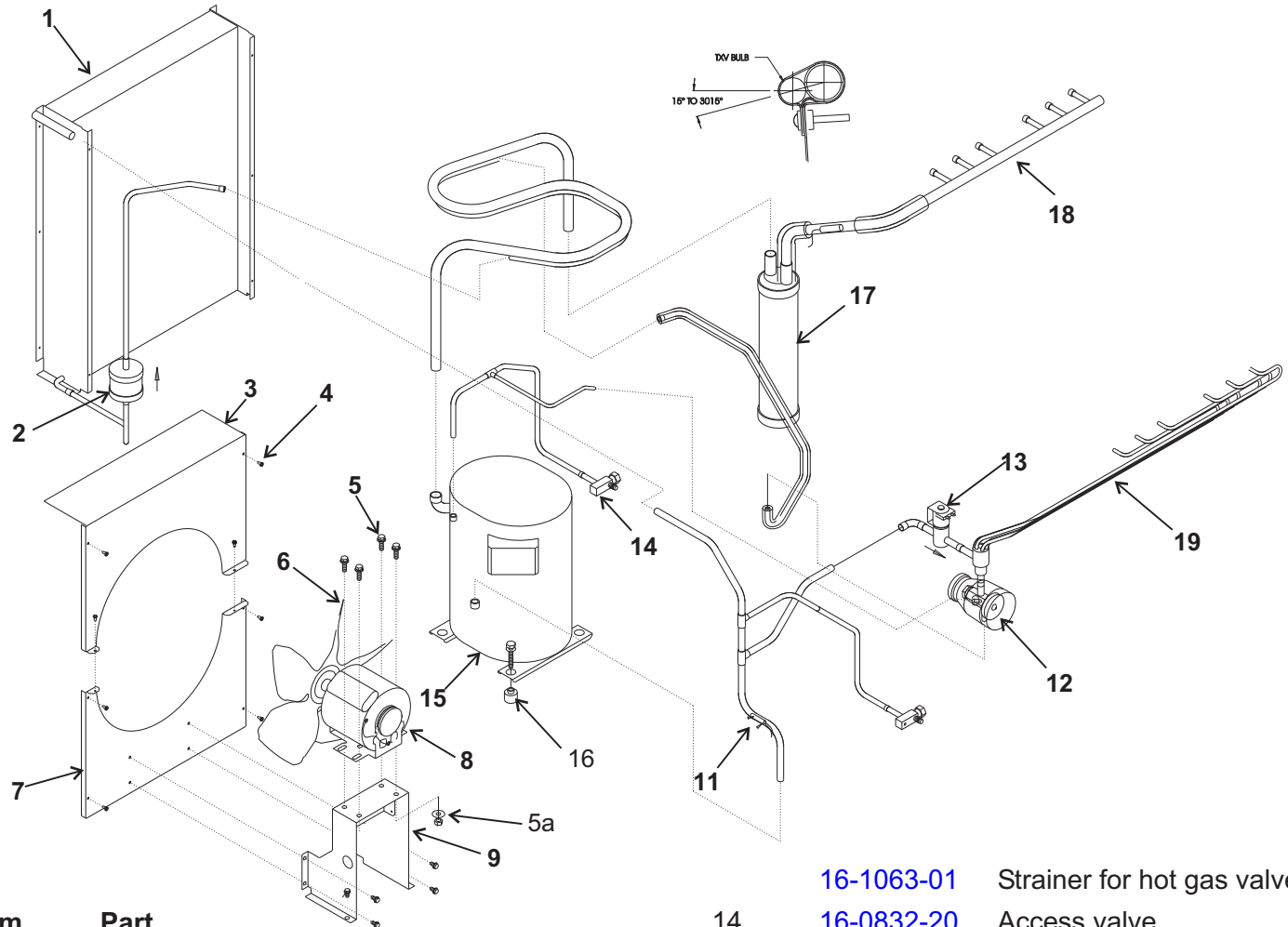

Item Number	Part Number	Description
1	18-8817-01	Air cooled condenser
2	02-3319-02	Filter dryer
3	A37205-001	Top fan shroud
4	03-1531-01	Screw
5	03-1251-01	Hex cap screw
5a	03-1406-10	Nut
6	18-8765-01	Fan blade
7	A37206-001	Bottom fan shroud
8	18-8818-01	Fan motor
9	A37207-001	Fan bracket
10	03-1645-01	Screw
11	11-0515-21	Temp sensor set
12	16-1066-21	TXV, ANE1 ¼ SZ
	02-3396-01	Insulation for TXV
13	11-0507-01	Hot gas valve, 1356
	11-0507-02	Hot gas valve, 1656
	12-2719-23	Coil for hot gas valve
	16-1063-01	Strainer for hot gas valve
14	16-0832-20	Access valve
	16-0832-03	Port cap
	16-0832-02	Stem cap
15	18-8751-23	Compressor, 60 Hz, single phase
	18-8751-29	Compressor, 60 Hz, 3 phase
	18-8751-27	Compressor, 50 Hz, single phase
16	18-2300-27	Grommet
	18-2200-27	Sleeve
	03-1405-20	Bolt
	03-1407-07	Washer
17	16-1031-21	Accumulator
18	16-1032-02	Suction manifold, 1656
	16-1032-01	Suction manifold, 1356
19	A37312-021	Distributor and tubes, 1356
	A37312-022	Distributor and tubes, 1656

CME1356 and CME1656 Service Parts

Water Cooled Refrigeration

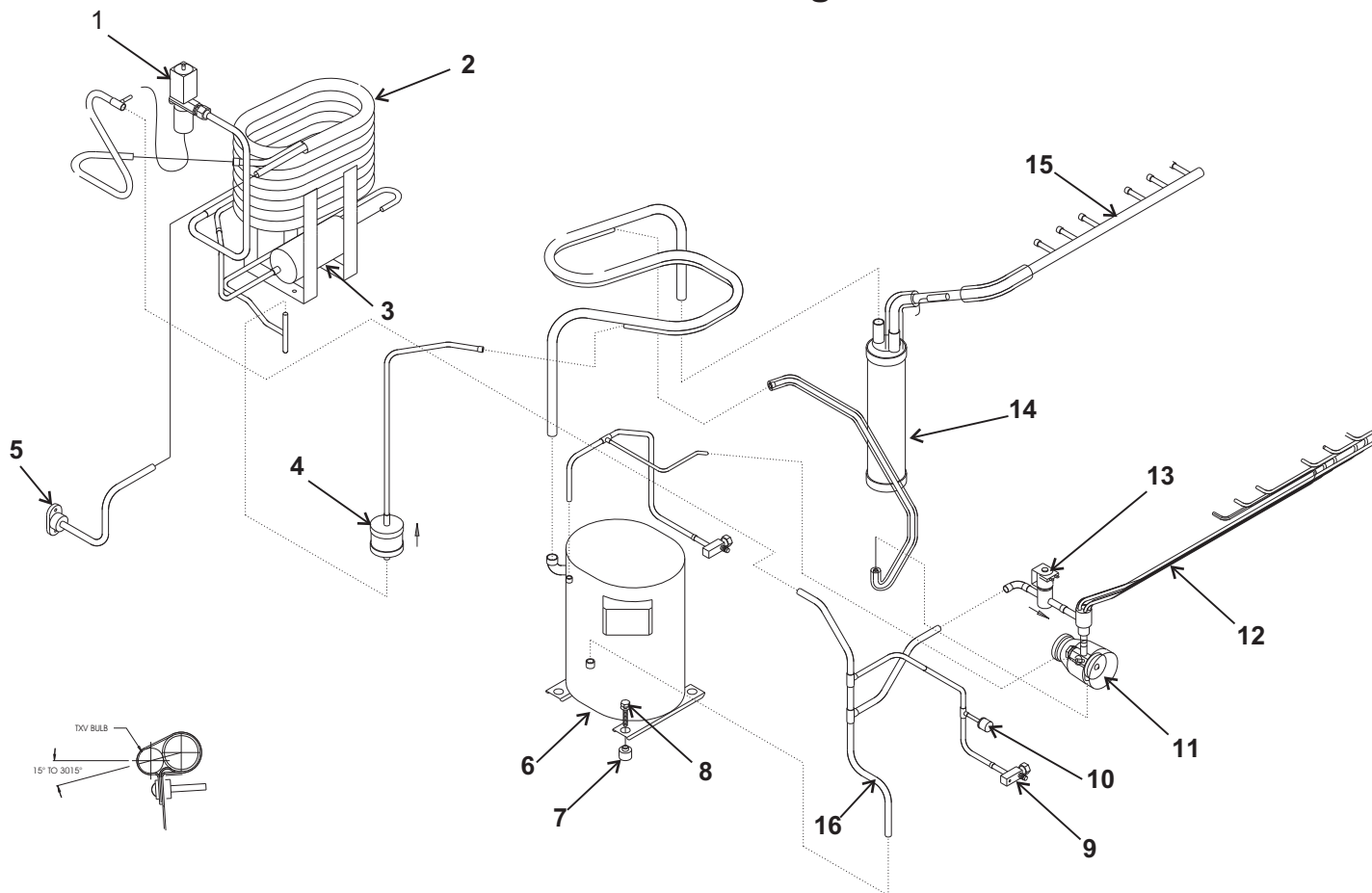

Item Number	Part Number	Description	Item Number	Part Number	Description
1	11-0608-21	Water regulating valve	9	16-0832-20	Access valve
2	18-8767-25	A - E series water cooled condenser		16-0832-03	Port cap
	18-8865-21	F & higher series water cooled condenser		16-0832-02	Stem cap
3	02-2628-02	Receiver	10	11-0501-21	Hi pressure cut out
4	02-3319-02	Filter dryer	11	16-1066-21	TXV, ANE1 ¼ SZ
5	A31828-003	Adapter		02-3396-01	Insulation for TXV
6	Compressors:		12	A37312-021	Distributor and tubes, 1356
	18-8751-23	60 Hz, single phase		A37312-022	Distributor and tubes, 1656
	18-8751-29	60 Hz, 3 phase	13	11-0507-01	Hot gas valve, 1356
	18-8751-27	50 Hz, single phase		11-0507-22	Hot gas valve, 1656
7	18-2300-27	Grommet		16-1063-01	Strainer for hot gas valve
	18-2200-27	Sleeve	14	16-1031-21	Accumulator
8	03-1405-20	Bolt	15	16-1032-02	Suction manifold, 1656
	03-1407-07	Washer		16-1032-01	Suction manifold, 1356
			16	11-0515-21	Temp sensor set

CME1356 and CME1656 Service Parts

Electrical



Single Phase

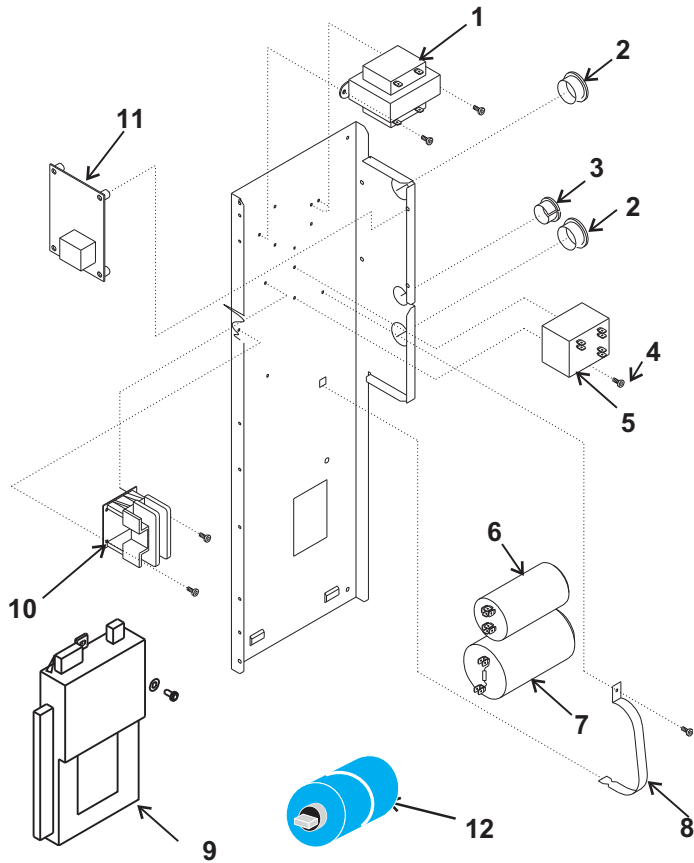

Three Phase

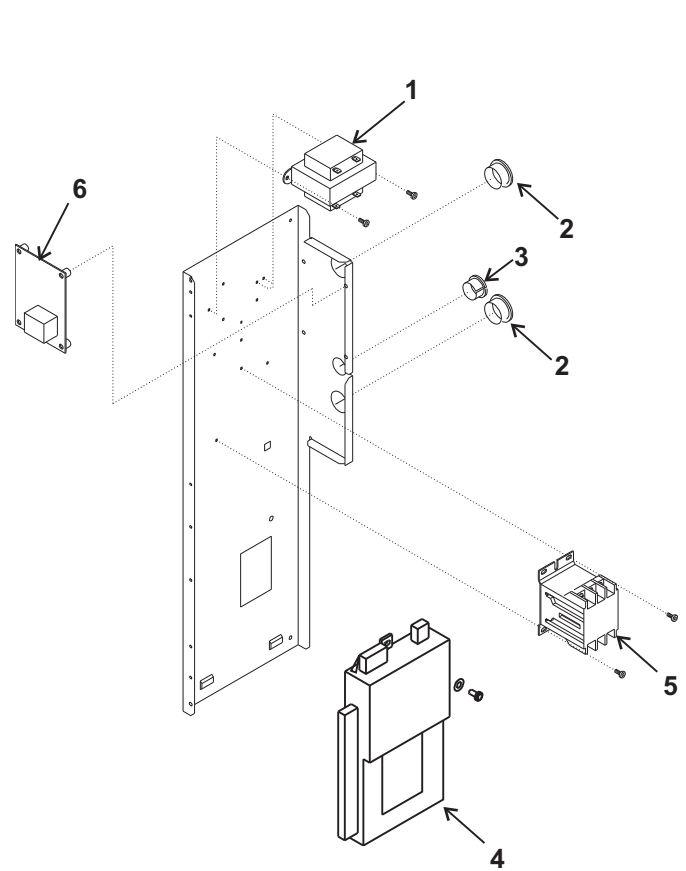

Single Phase

Item Number	Part Number	Description
1	A37217-001	Transformer
2	12-1213-11	Snap bushing
3	12-1213-10	Snap bushing
4	03-1531-01	Screw
5	18-1903-46	60 Hz potential relay
	18-1903-56	50 Hz potential relay
6	18-1902-56	Run capacitor
7	18-1901-27	60 Hz start capacitor
	18-1901-57	50 Hz start capacitor
8	A37125-001	Strap
9	12-2838-24	Controller Kit
10	12-2469-01	Single phase contactor
11	11-0531-22	Purge valve timer
12	18-8840-01	PTCR
12a	18-8840-02	PTCR Bracket

Three Phase

Item Number	Part Number	Description
1	A37217-001	Transformer
2	12-1213-11	Snap bushing
3	12-1213-10	Snap bushing
4	12-2838-24	Controller
5	12-2533-01	Three phase contactor
6	11-0531-22	Purge valve timer

Not Shown

11-0521-21	Bin thermostat
02-3740-01	Thermostat bracket
03-1675-03	3 pronged knob
12-2701-01	Bin thermo harness
12-2663-01	Lo voltage harness, A-C
12-2659-01	Hi voltage harness, A-C
12-2679-01	Relay, -6 B thru H
12-2686-01	Fuse, -6 B thru H
12-2639-02	Transformer, -6 B, thru H
12-2798-01	Hi volt harness, -6 B thru H
12-2738-01	Lo volt harness, -6 B thru C
12-2792-01	Lo volt harness, -6 D thru H
D thru H series:	
12-2791-01	Lo voltage harness, 60 Hz
12-2796-01	Hi voltage harness, 60 Hz

CME1356 and CME1656 Service Parts

BH900 Ice Storage Bin

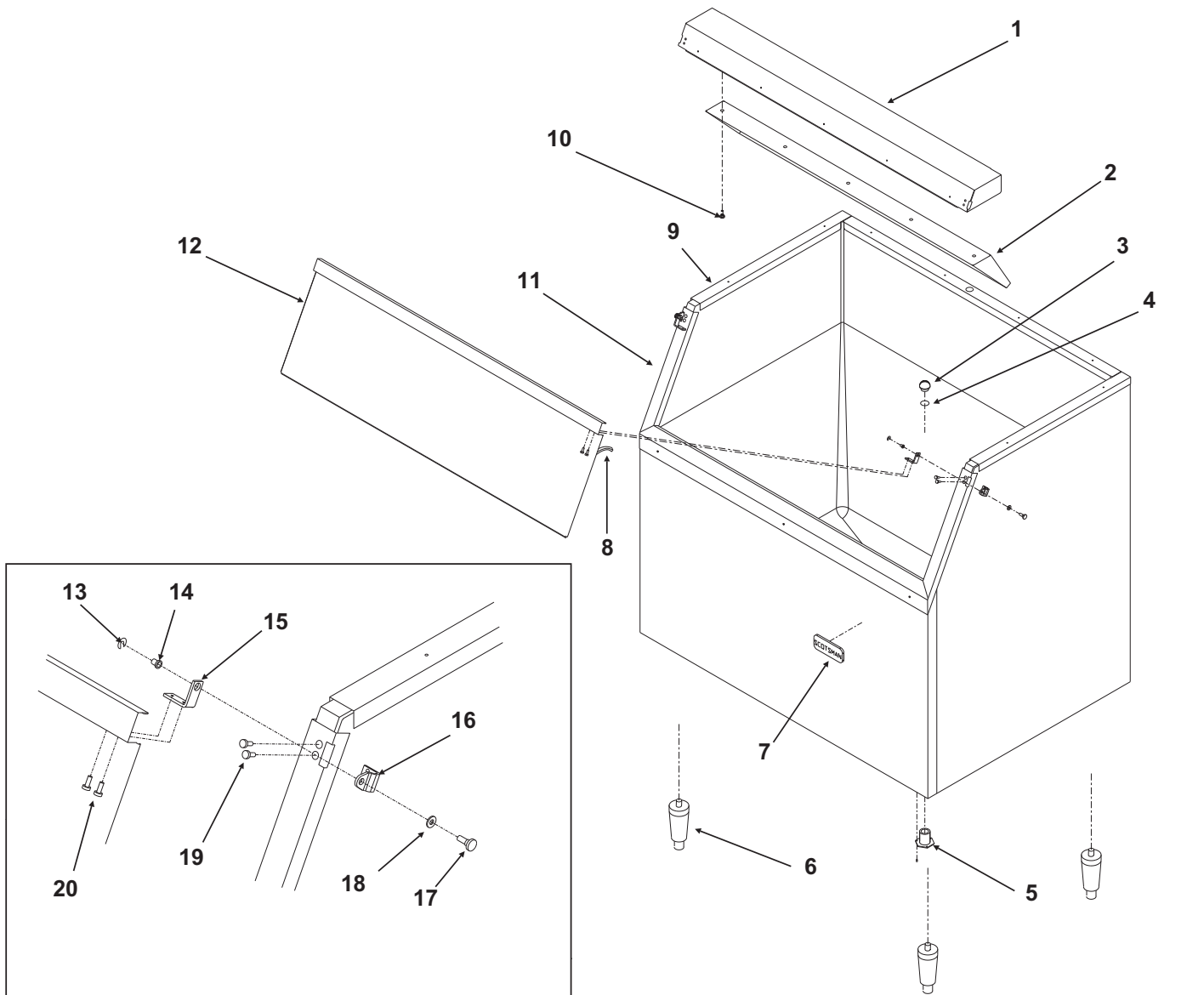

ITEM NUMBER	PARTS NUMBER	DESCRIPTION
1	A35322-020	Canopy Assembly
2	A35152-001	Ice Baffle
3	02-2809-01	Drain Top
4	13-0617-11	O-ring
5	02-3201-01	Drain casting
6	KLP2E	Leg Kit, Black
7	15-0808-01	Emblem
8	13-0595-00	Door gasket(order qty 7)
9	19-0503-04	Bin gasket (order by foot)
10	03-0727-11	Baffle screw
11	A35275-001	Door frame assy. except C
	A37641-021	C series door frame
12	A35323-020	Door with gasket - BH900
13	03-1539-09	"E" ring
14	02-2380-01	Hinge bushing
15	02-3195-01	Door hinge
16	02-3196-01	Bin hinge
17	02-2806-01	Shoulder screw
18	02-2380-02	Spacer
19	03-1403-29	Screw 10-24
20	03-1403-24	Screw 10-24

CME1356 and CME1656 Service Parts

BH1356 Ice Storage Bin

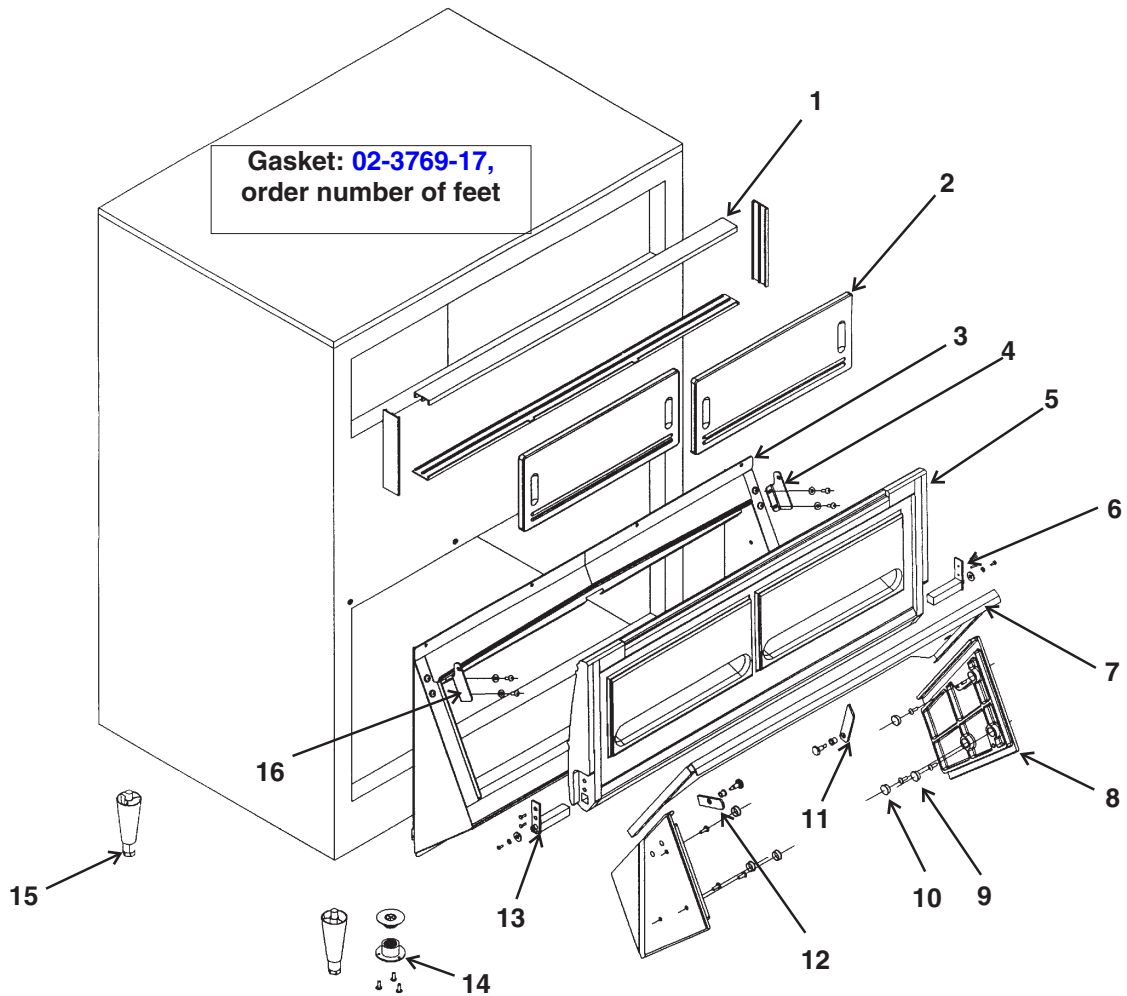

Item Number	Part Number	Description
1	02-3769-02	Track
2	02-3769-16	Window
3	02-3769-04	Lower frame assembly
4	02-3769-08	Left and right hinges
5	02-3769-05	Door with door hinges
6	02-3769-07	Right hinge
7	02-3769-09	Ice gate
8	02-3769-12	End plate guide (pair)
9	02-3769-13	Screws for end plate
10	02-3769-14	Plugs for end plate
11	02-3769-10	Catch for ice gate
12	02-3769-15	Ice gate retainer
13	02-3769-06	Left hinge
14	02-3769-01	Plastic drain
15	KLP2S	Legs

CME1356 and CME1656 Service Parts Kit Parts

Stacking Kit - KSCME6-LG

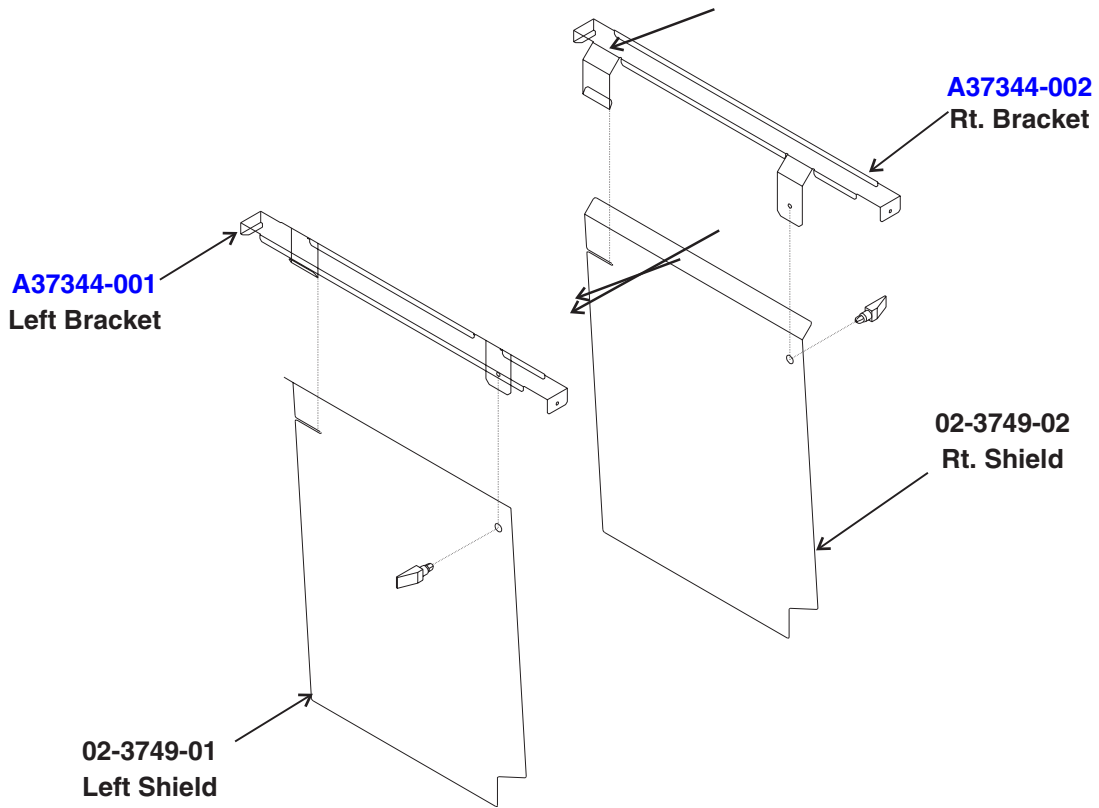

Stacking Kit **KSCME6-LG-B**

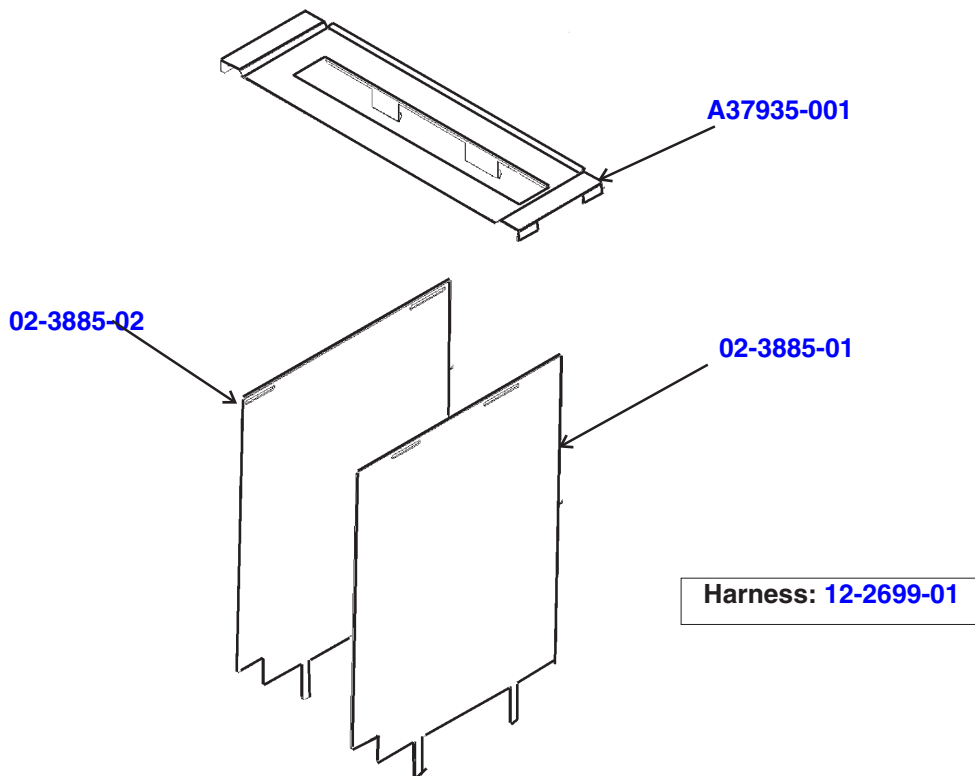

CME1356 and CME1656 Service Parts

Single Phase Schematic Diagram, D - H Series

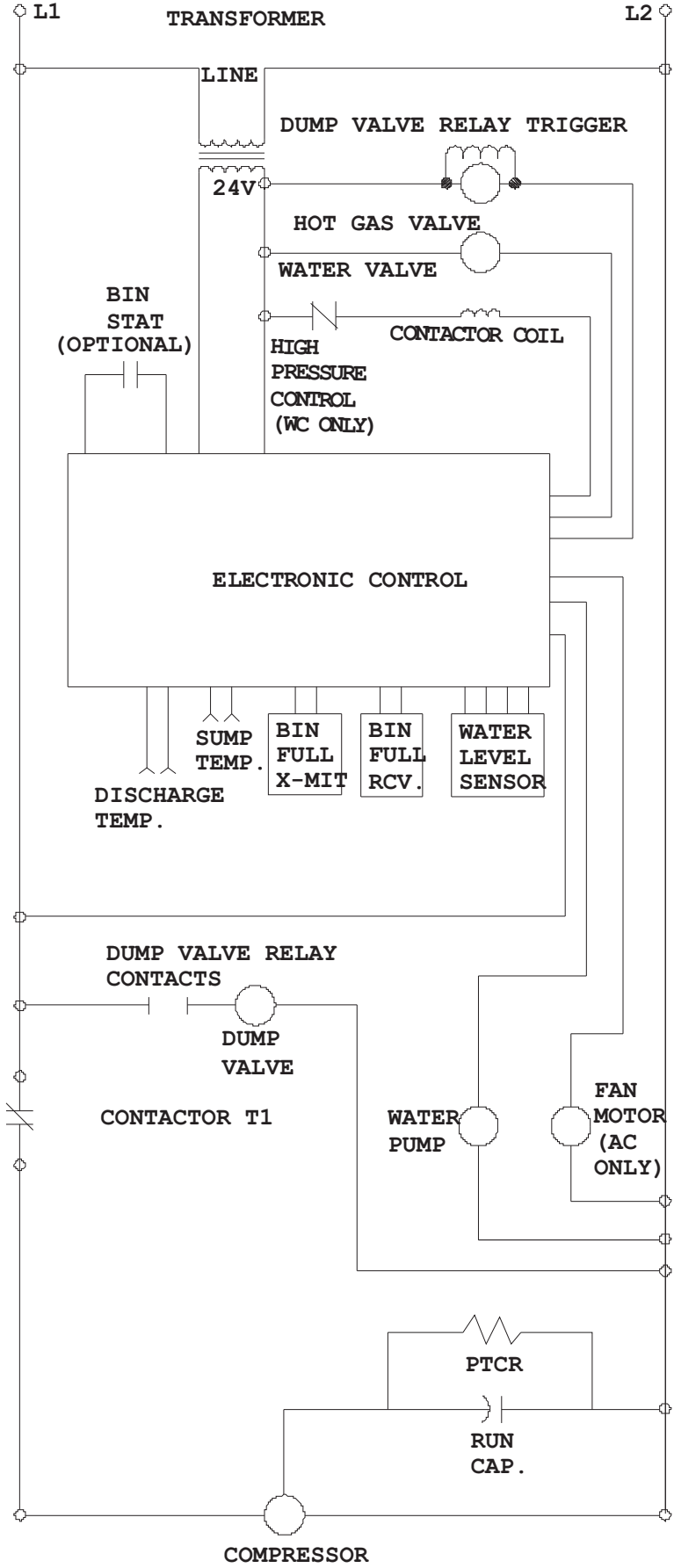

CME1356 and CME1656 Service Parts

Single Phase 60 Hz Wiring Diagram, D - H Series

17-2820-01

USE COPPER CONDUCTORS ONLY

△ DASHED LINES INDICATE FIELD WIRING WHICH MUST BE INSTALLED IN ACCORDANCE WITH THE NATIONAL ELECTRICAL CODE AND ALL STATE AND LOCAL CODES

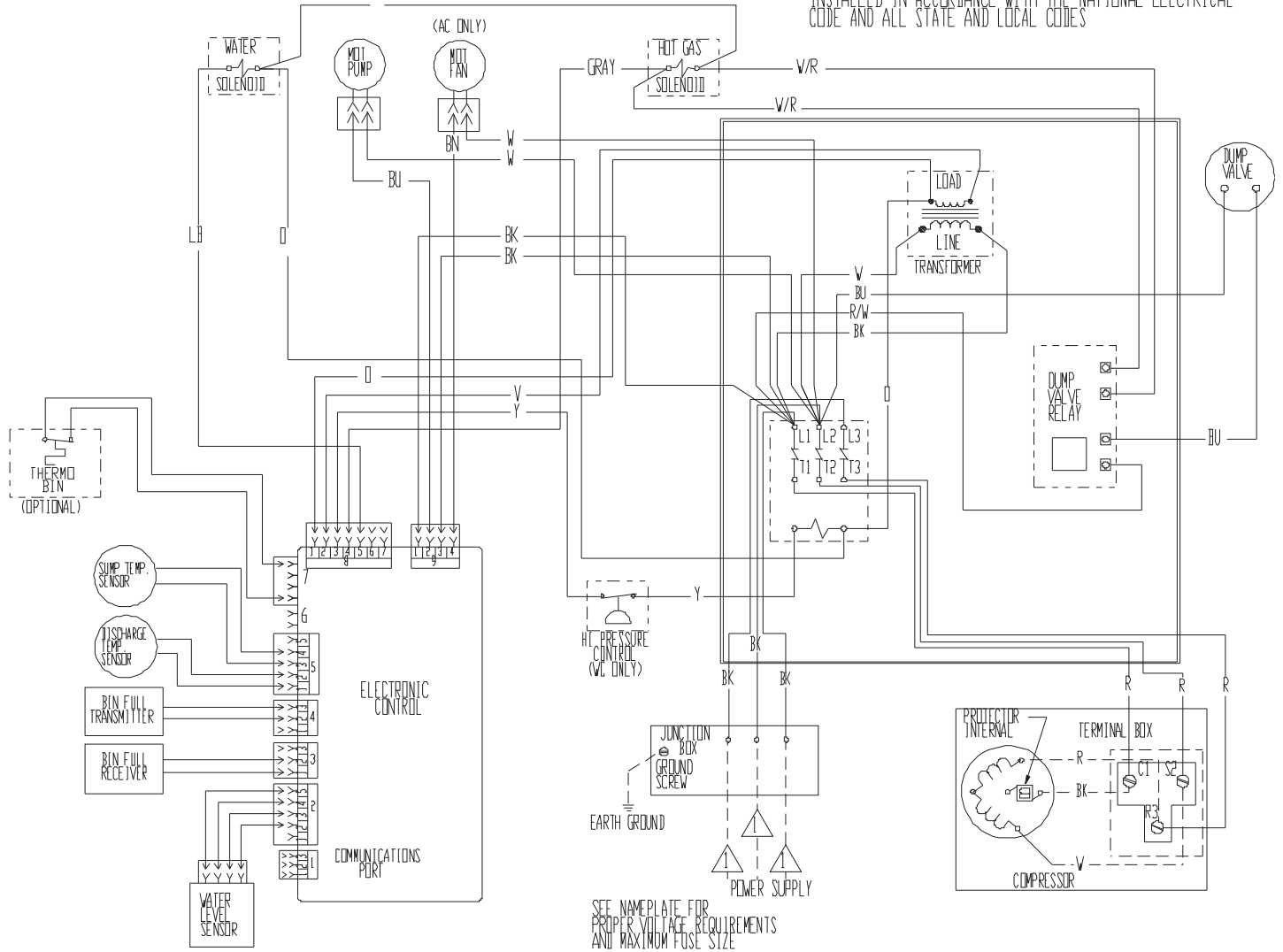

THIS UNIT MUST BE GROUNDED.

CAUTION: MORE THAN ONE DISCONNECT MEANS MAY BE REQUIRED TO DISCONNECT ALL POWER TO THIS UNIT.

CME1356 and CME1656 Service Parts

Three Phase Wiring Diagram, D - H Series

▲ DASHED LINES INDICATE FIELD WIRING WHICH MUST BE INSTALLED IN ACCORDANCE WITH THE NATIONAL ELECTRICAL CODE AND ALL STATE AND LOCAL CODES.

▲ SEE NAMEPLATE FOR PROPER VOLTAGE REQUIREMENTS AND MAXIMUM FUSE SIZE

USE COPPER CONDUCTORS ONLY

17-2776-01

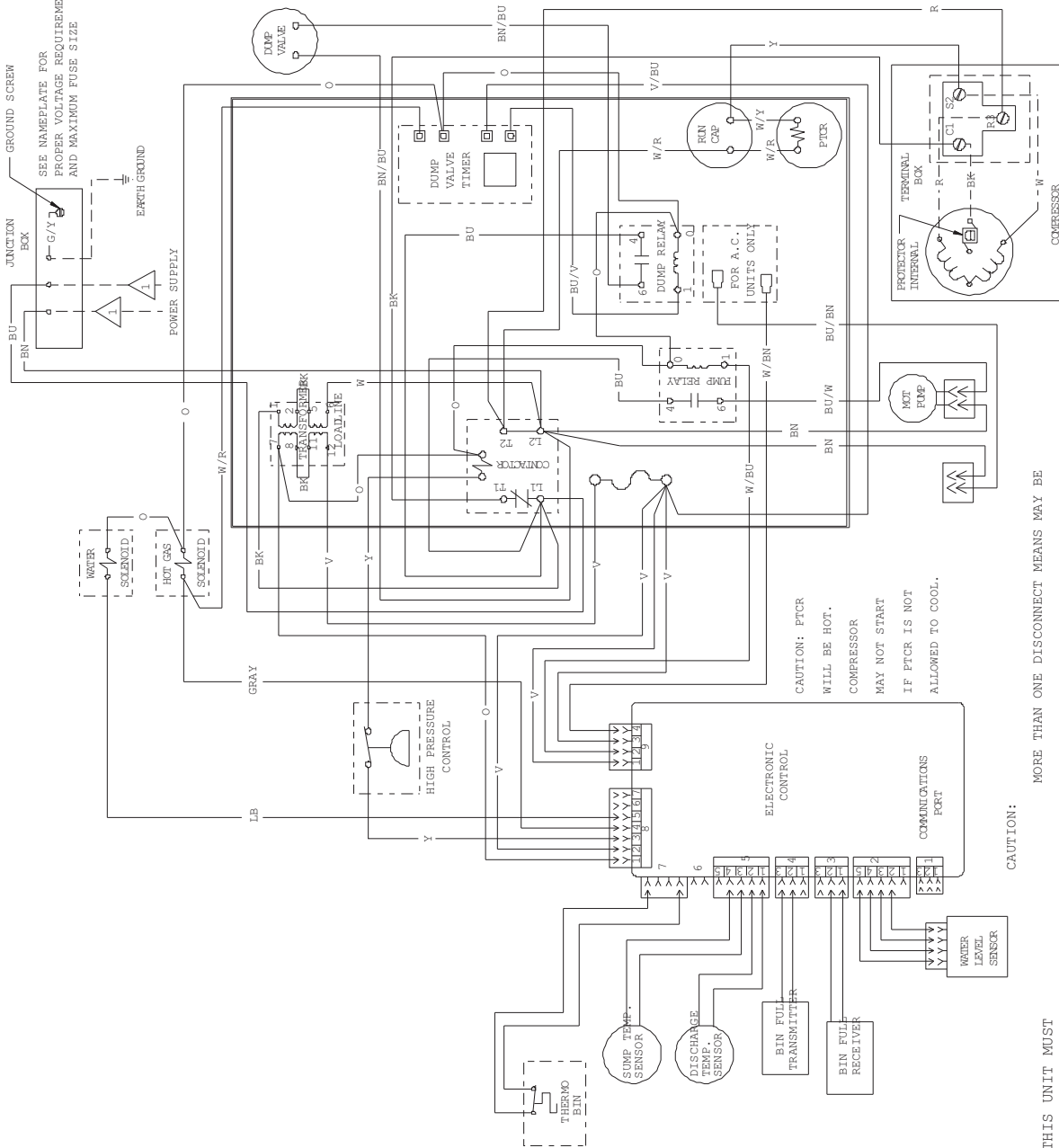
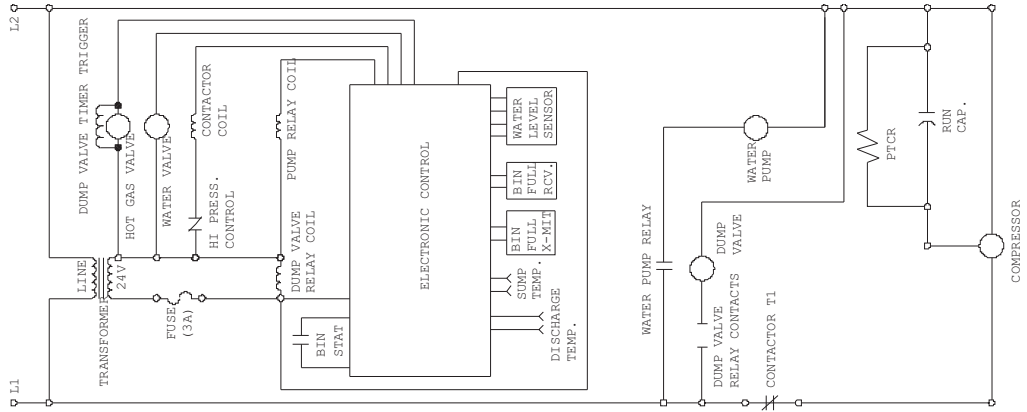

CAUTION: PTCR WILL BE HOT. COMPRESSOR MAY NOT START IF PTCR IS NOT ALLOWED TO COOL.

THIS UNIT MUST BE GROUNDED.

CAUTION: MORE THAN ONE DISCONNECT MEANS MAY BE REQUIRED TO DISCONNECT ALL POWER TO THIS UNIT.

CME1356 and CME1656 Service Parts

Single Phase 50 Hz Air Cooled Wiring Diagram, D - H Series

17-2502-01

USE COPPER CONDUCTORS ONLY

⚠ DASHED LINES INDICATE FIELD WIRING WHICH MUST BE INSTALLED IN ACCORDANCE WITH THE NATIONAL ELECTRICAL CODE AND ALL STATE AND LOCAL CODES.

⚠ WIRE COLOR FOR 208-230/60/1 UNITS: BLACK
WIRE COLOR FOR 230/50/1 UNITS : BROWN

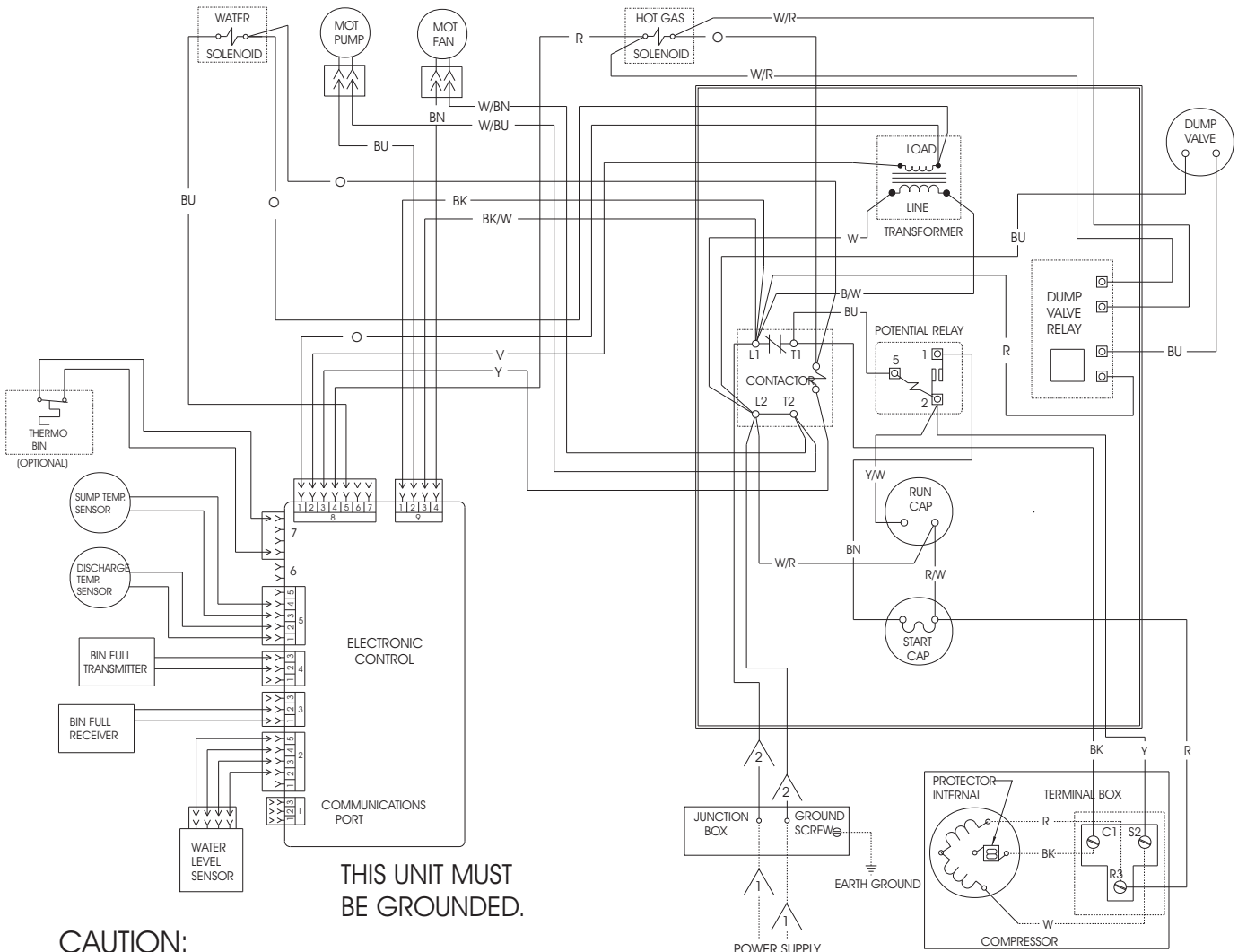

THIS UNIT MUST BE GROUNDED.

CAUTION:
MORE THAN ONE DISCONNECT MEANS MAY BE REQUIRED TO DISCONNECT ALL POWER TO THIS UNIT.

SEE NAMEPLATE FOR PROPER VOLTAGE REQUIREMENTS AND MAXIMUM FUSE SIZE

CME1356 and CME1656 Service Parts

Single Phase, 50 Hz Water Cooled Wiring Diagram, D - H Series

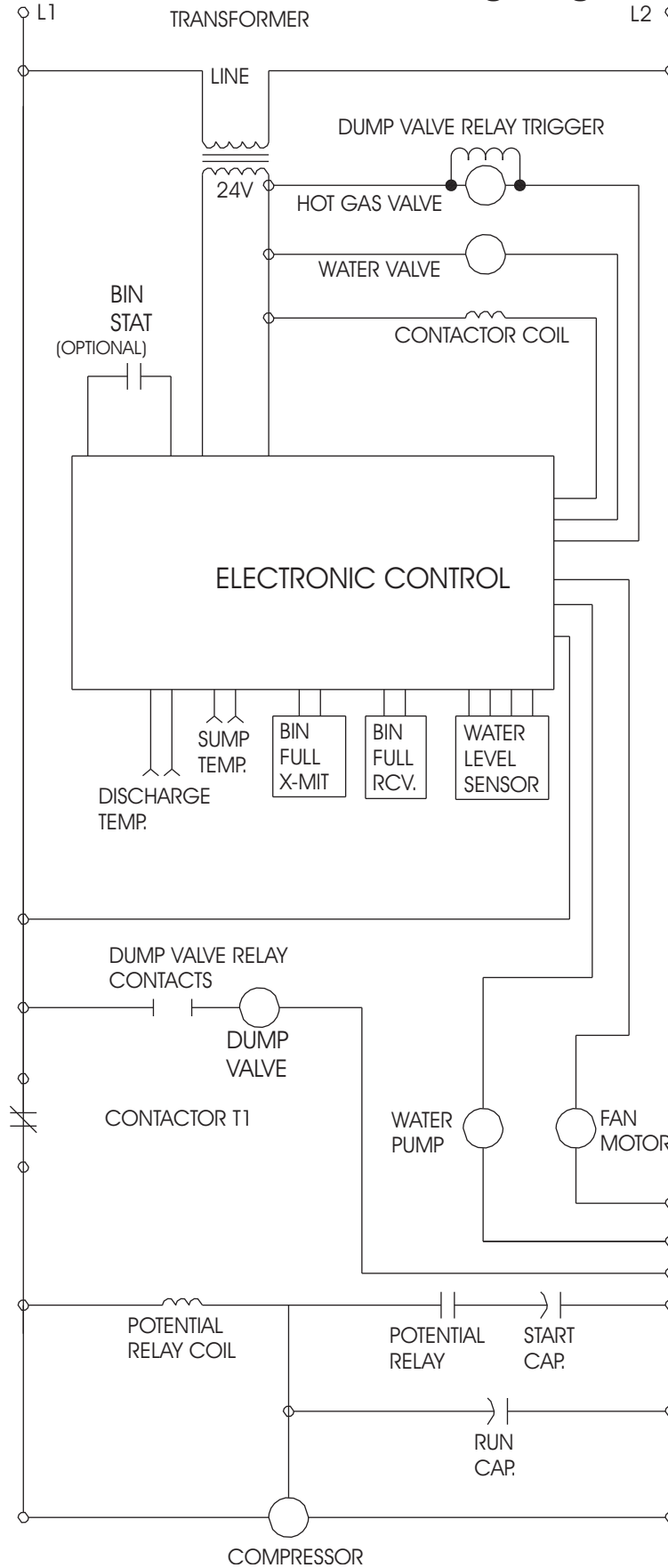

CME1356 and CME1656 Service Parts

Air Cooled Three Phase Wiring Diagram, A - C

17-2511-03

USE COPPER CONDUCTORS ONLY  DASHED LINES INDICATE FIELD WIRING WHICH MUST BE INSTALLED IN ACCORDANCE WITH THE NATIONAL ELECTRICAL CODE AND ALL STATE AND LOCAL CODES.

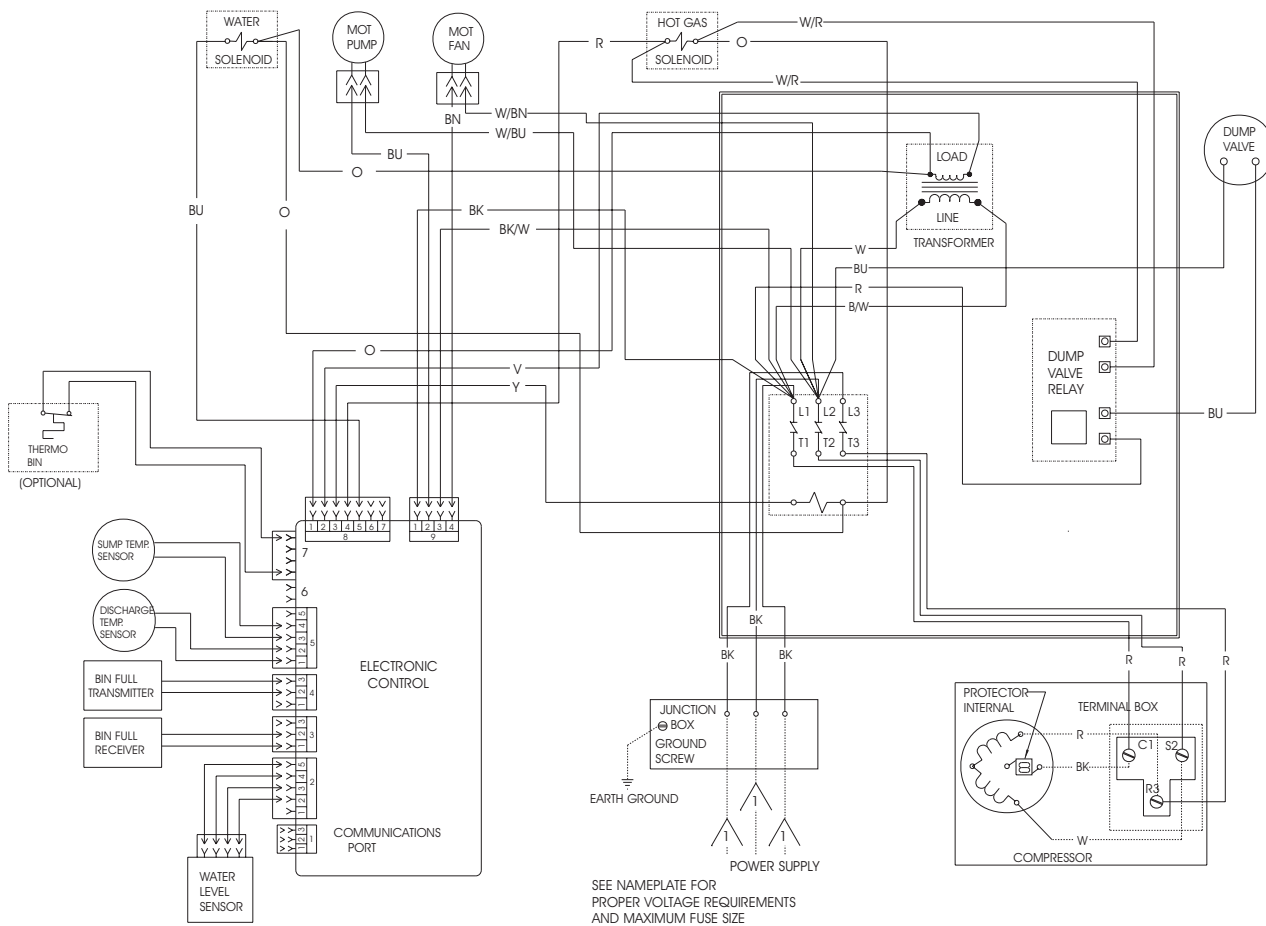

CAUTION:

THIS UNIT MUST
BE GROUNDED.

MORE THAN ONE DISCONNECT MEANS MAY BE
REQUIRED TO DISCONNECT ALL POWER TO THIS UNIT.

CME1356 and CME1656 Service Parts

Air Cooled Three Phase Schematic Diagram

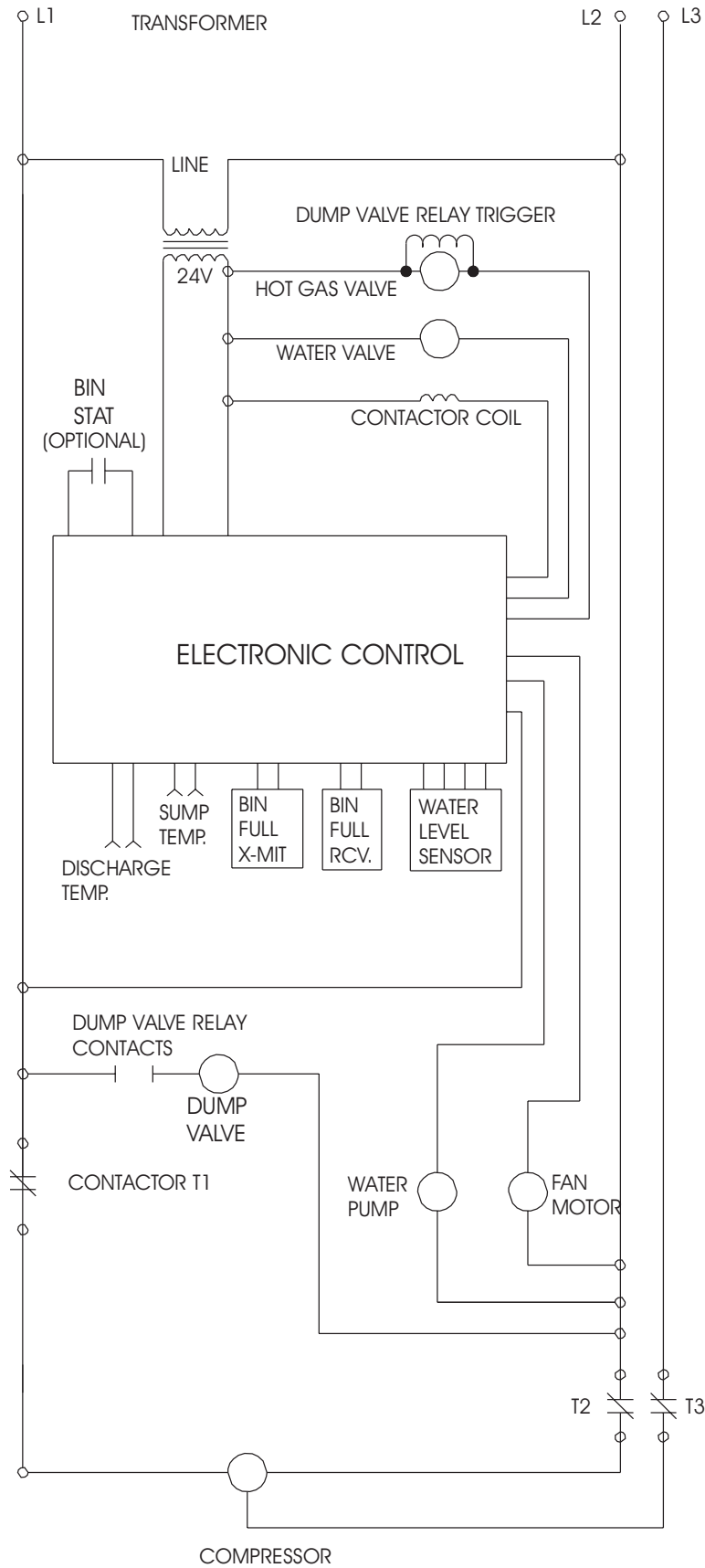

CME1356 and CME1656 Service Parts

Water Cooled Single Phase Wiring Diagram, A - C

17-2503-01

USE COPPER CONDUCTORS ONLY

- △ 1 DASHED LINES INDICATE FIELD WIRING WHICH MUST BE INSTALLED IN ACCORDANCE WITH THE NATIONAL ELECTRICAL CODE AND ALL STATE AND LOCAL CODES.
- △ 2 WIRE COLOR FOR 208-230/60/1 UNITS: BLACK
WIRE COLOR FOR 230/50/1 UNITS : BROWN

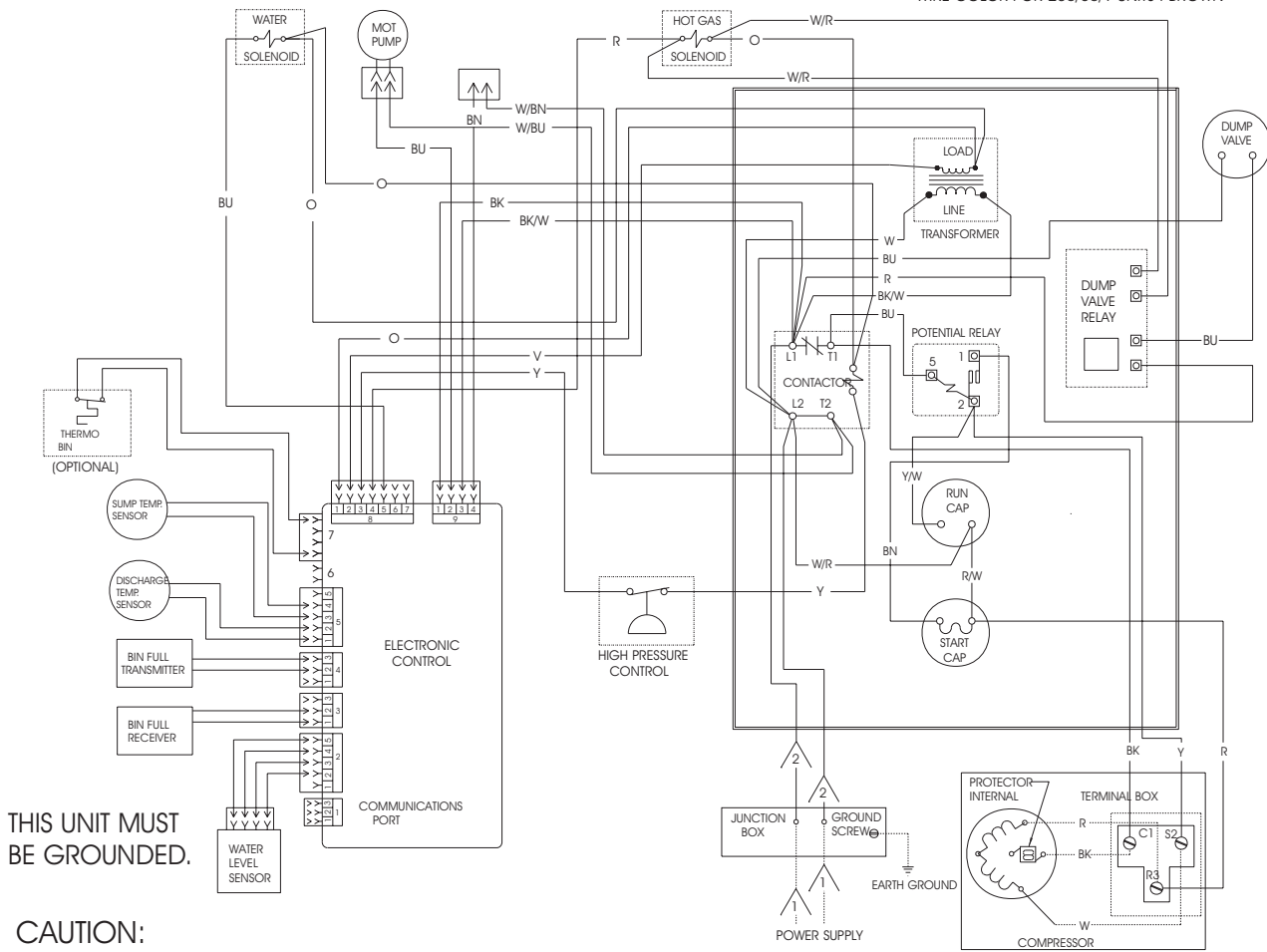

THIS UNIT MUST BE GROUNDED.

CAUTION:
MORE THAN ONE DISCONNECT MEANS MAY BE REQUIRED TO DISCONNECT ALL POWER TO THIS UNIT.

SEE NAMEPLATE FOR PROPER VOLTAGE REQUIREMENTS AND MAXIMUM FUSE SIZE

CME1356 and CME1656 Service Parts

Water Cooled Single Phase Schematic Diagram, A - C

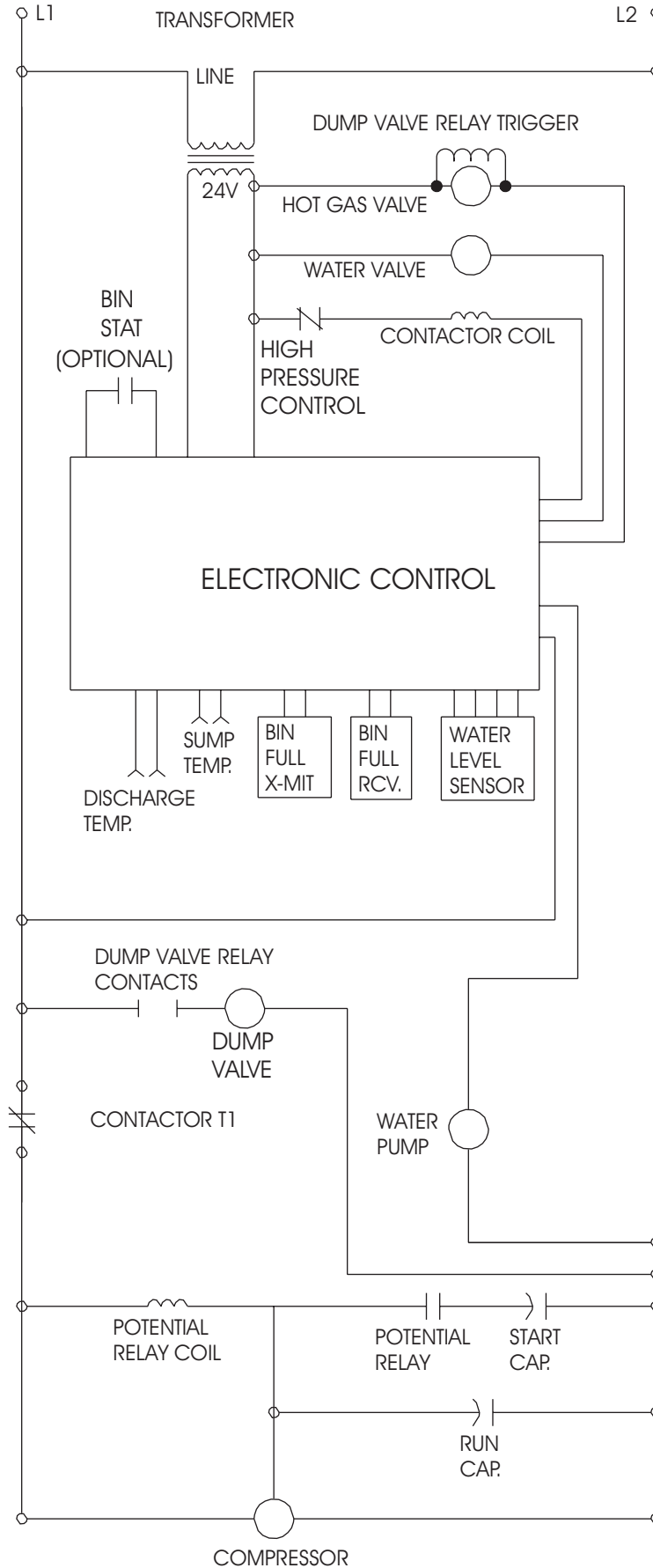

CME1356 and CME1656 Service Parts

Water Cooled Three Phase Wiring Diagram

17-2512-03

USE COPPER CONDUCTORS ONLY

⚠ DASHED LINES INDICATE FIELD WIRING WHICH MUST BE INSTALLED IN ACCORDANCE WITH THE NATIONAL ELECTRICAL CODE AND ALL STATE AND LOCAL CODES.

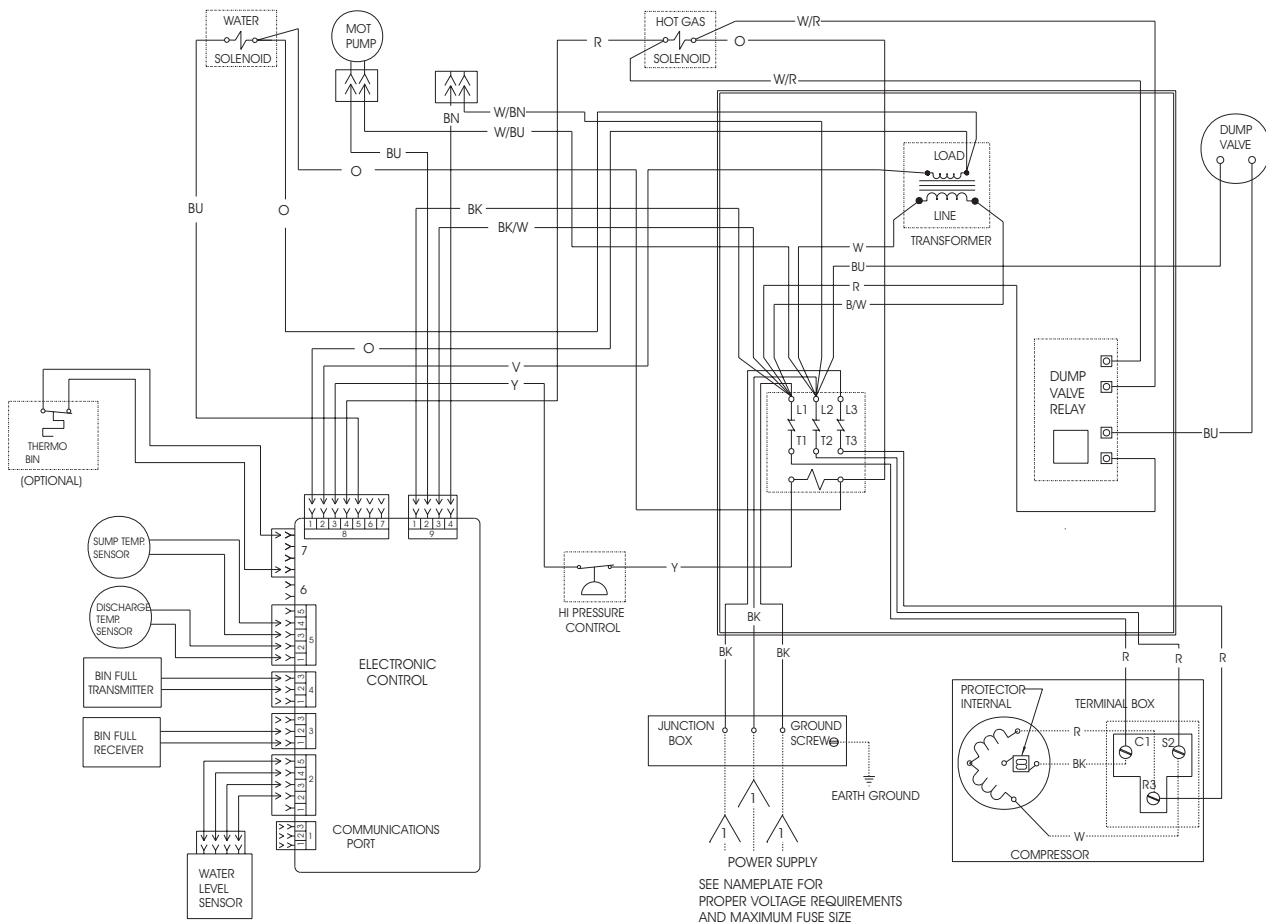

CAUTION:

THIS UNIT MUST BE GROUNDED.

MORE THAN ONE DISCONNECT MEANS MAY BE REQUIRED TO DISCONNECT ALL POWER TO THIS UNIT.

CME1356 and CME1656 Service Parts

Water Cooled Three Phase Schematic Diagram

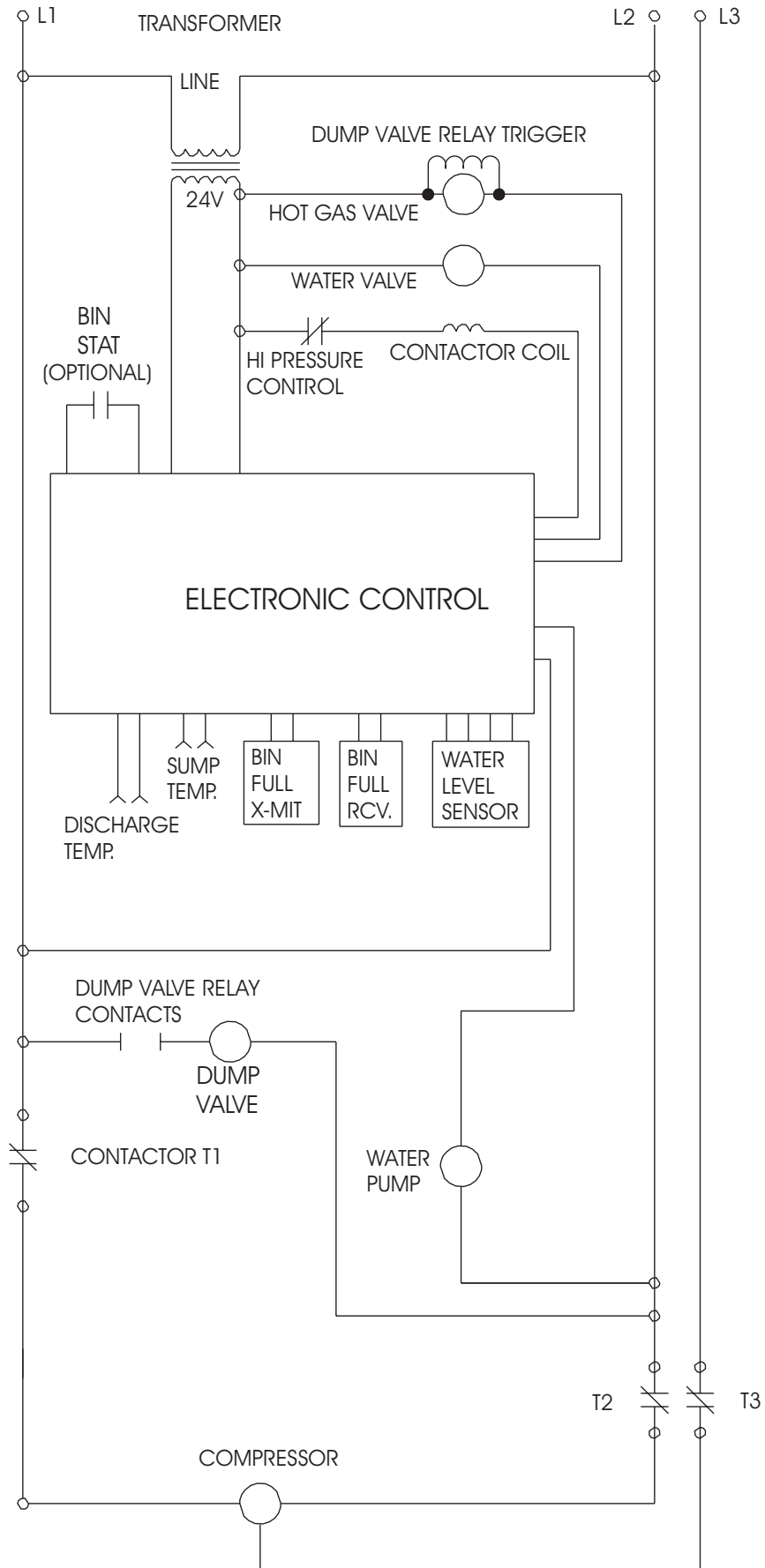

SERVICE BULLETIN

Subject: Controller Cover

Affects all versions of models: CME1356, CME1656, CME1856 and CME2006

The above models are now manufactured with a sheet metal cover over the top of the controller.

Service controllers also are now shipped with a cover that should be applied to these models whenever replacing the controller if the machine does not already have a cover installed.

Whenever cleaning or servicing any unit, check to see whether it has a cover over the controller like the one shown below. If it does not, Scotsman recommends installing a cover. A separate part is now available for this purpose. Its part number is [A37480-021](#). It mounts over the top end of the controller and is secured by two sheet metal screws. Use the cover as a template and drill two 1/8" holes for the two screws.

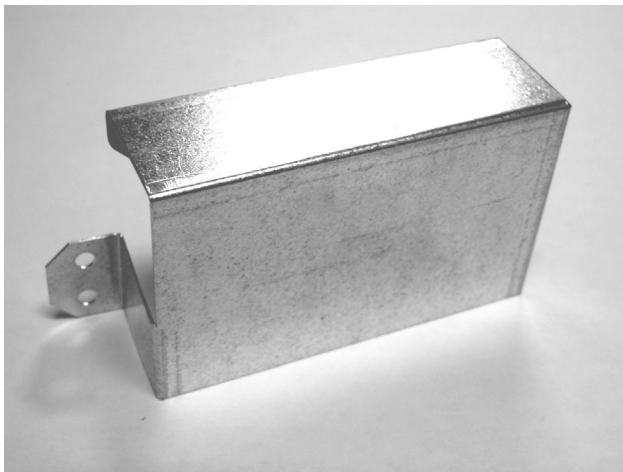

Controller Cover

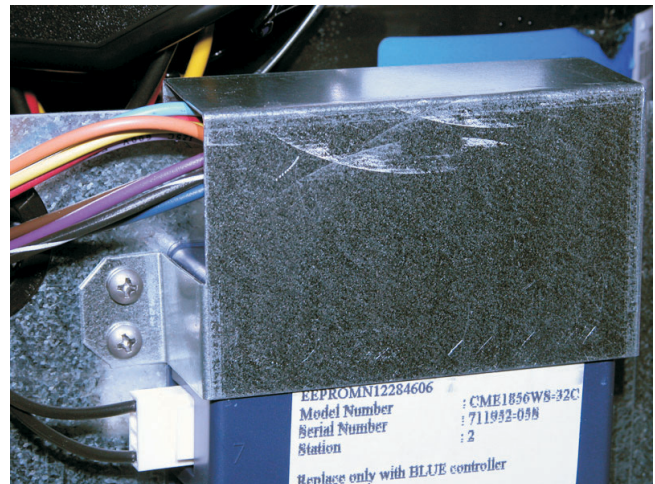

Cover Installed on Unit

Scotsman is shipping a supply of covers to all Scotsman Distributors and listed service agencies. A supply of covers should be carried by each service person on service calls so a cover may be installed on the unit being cleaned or serviced if one is not already in place. Additional covers may be obtained free of charge from Scotsman, through the local Scotsman Distributor, as needed.