

Scotsman[®]

Ice Systems

Service Manual for Meridian Ice Maker-Dispensers Models HID312, HID525 and HID540

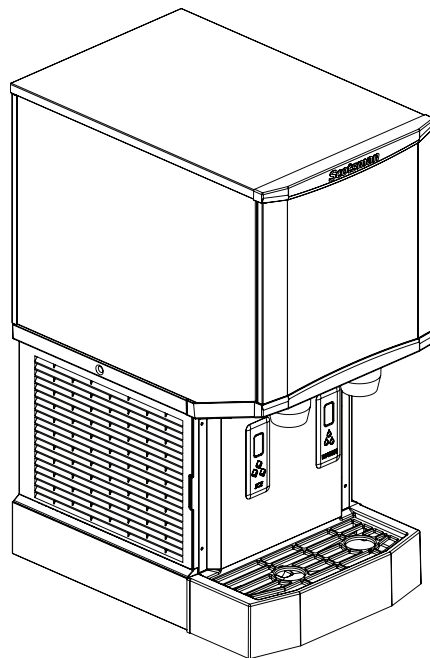
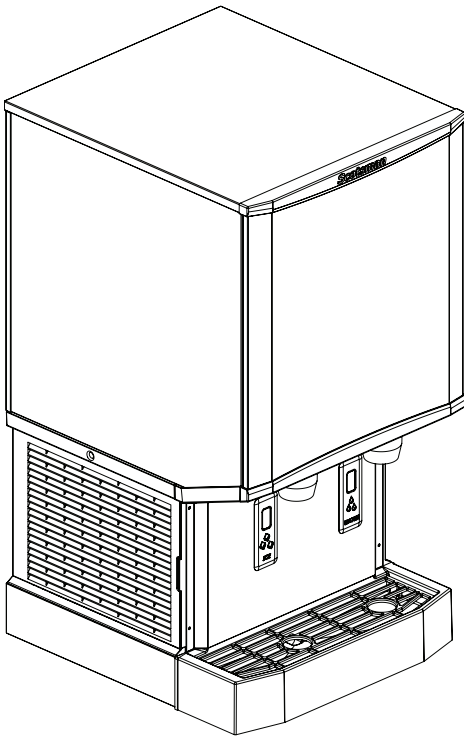

HID312, HID525, HID540

Service Manual

Introduction

The ice maker-dispensers covered in this manual were designed by to be the finest on the market. Their design is a result of Scotsman's long experience in ice maker-dispensers.

HID312 is 16 inches wide and air cooled only.

HID525 is 21 inches wide and 34.9 inches tall. it is available as an air cooled or water cooled model.

HID540 is also 21 inches wide, but it is 40.9 inches tall. it is also available either air or water cooled.

Observe any caution or warning notices. They are important and provide notice of potential hazards. Keep this manual for future reference.

Contents

Specifications	3
HID312 Cabinet Drawing.	4
HID525 Cabinet Drawing.	5
HID540 Cabinet Drawing.	6
Placement	7
Counter Installations	8
Differences Between Models	9
Component Location	10
Installation	11
Start Up	12
Operation: Ice and Water Vending	13
Controller.	14
Controller Functions	15
Maintenance and Cleaning	16
Air filter	17
Maintenance and Cleaning - Dispensing Bin Components	18
Ice level controls	19
Dispensing Bin.	20
Ice Making and Ice Dispensing System Cleaning Instructions	21
Other Maintenance	23
Basic Troubleshooting.	24
Troubleshooting	25
Controller Diagnostics	26
Test Procedures	27
Test Procedures	28
Test Procedures - Refrigeration	29
Test Procedures Auger and Gear Reducer	30
Dispensing Motor.	31
Photo Eye - Bin Control	32
Gear Reducer	33
Auger	34
Evaporator	35
Water Seal and Auger Bearings	36
HID312 Wiring Diagram	37
HID312 Schematic Diagram	38
HID525 or 540 Wiring Diagram	39
HID525 or 540 Schematic Diagram.	40

HID312, HID525, HID540

Service Manual

Specifications

The ice maker-dispenser is designed to be installed indoors, in a controlled environment. Although it can operate in a wide range of air and water temperatures, it will provide the best performance if not subject to extremes.

Air Temperature Limitations

- Maximum: 100°F. or 38°C.
- Minimum: 50°F. or 10°C.

Water Temperature Limitations

- Maximum: 100°F. or 38°C.
- Minimum: 40°F. or 4.4°C.

Water Pressure, potable

- Maximum: 80 PSI or 5.5 Bar
- Minimum: 20 PSI or 1.3 Bar

Water Pressure, condenser inlet

- Maximum: 145 PSI or 10 Bar
- Minimum: 20 PSI or 1.3 bar; can be as low as 5 PSI or .3 Bar if clean & supplied with 45°F. water)

Condenser GPM

- 70°F. water: .25 or .95 LPM
- 50°F. water: .15 or .57 LPM

Water Conductivity:

- Minimum: 10 microSiemens/cm

RO water may be supplied to the potable water system, but if it has less than the above conductivity, the water level sensor will not detect water and the unit will not make ice.

Deionized water will not work and isn't recommended.

Voltage - 60 Hz

- Maximum: 126 Minimum: 104

Operating the machine outside of any of the above limitations is considered abuse and any resulting damage is not covered by warranty and could cause a complete loss of warranty coverage.

Warranty Information

The warranty statement for this product is provided separately from this manual. Refer to it for applicable coverage. In general warranty covers defects in material or workmanship. It does not cover maintenance, corrections to installations, or situations when the machine is operated in circumstances that exceed the limitations printed above.

Product Information

The product is an ice maker-dispenser. It is designed to be installed on a countertop or on a specific machine stand.

- All models require a drain. An internal drain basin separates the ice storage bin's drain from the drip tray drain.
- A backflow preventer may be required by local plumbing codes.
- 60 Hz model has a 7.5 ft. power cord with NEMA 5-15P plug.
- Air cooled models flow air left to right and include a cleanable air filter.
- 4" or 10 cm legs are optional for counter models. Thread size 3/8 - 16.
- Special models are required for wall mounting.
- Ice or water vending is triggered by touch free sensors, no other activation method is available.
- For available options and kits, see sales literature.

Scotsman Ice Systems are designed and manufactured with the highest regard for safety and performance.

Scotsman assumes no liability or responsibility of any kind for products manufactured by Scotsman that have been altered in any way, including the use of any part and/or other components not specifically approved by Scotsman.

Scotsman reserves the right to make design changes and/or improvements at any time. Specifications and design are subject to change without notice.

HID312, HID525, HID540

Service Manual

HID312 Cabinet Drawing

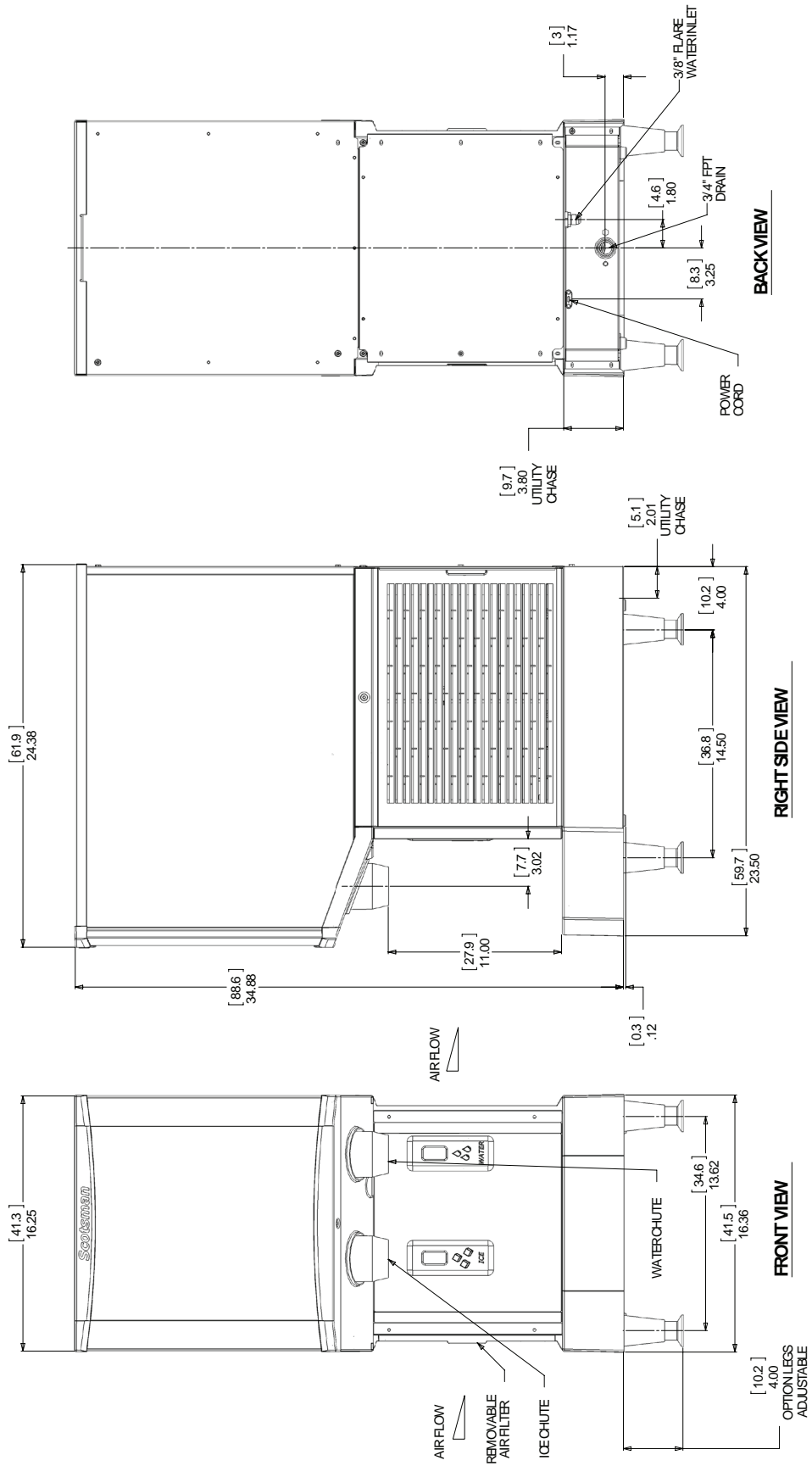

HID312, HID525, HID540

Service Manual

HID525 Cabinet Drawing

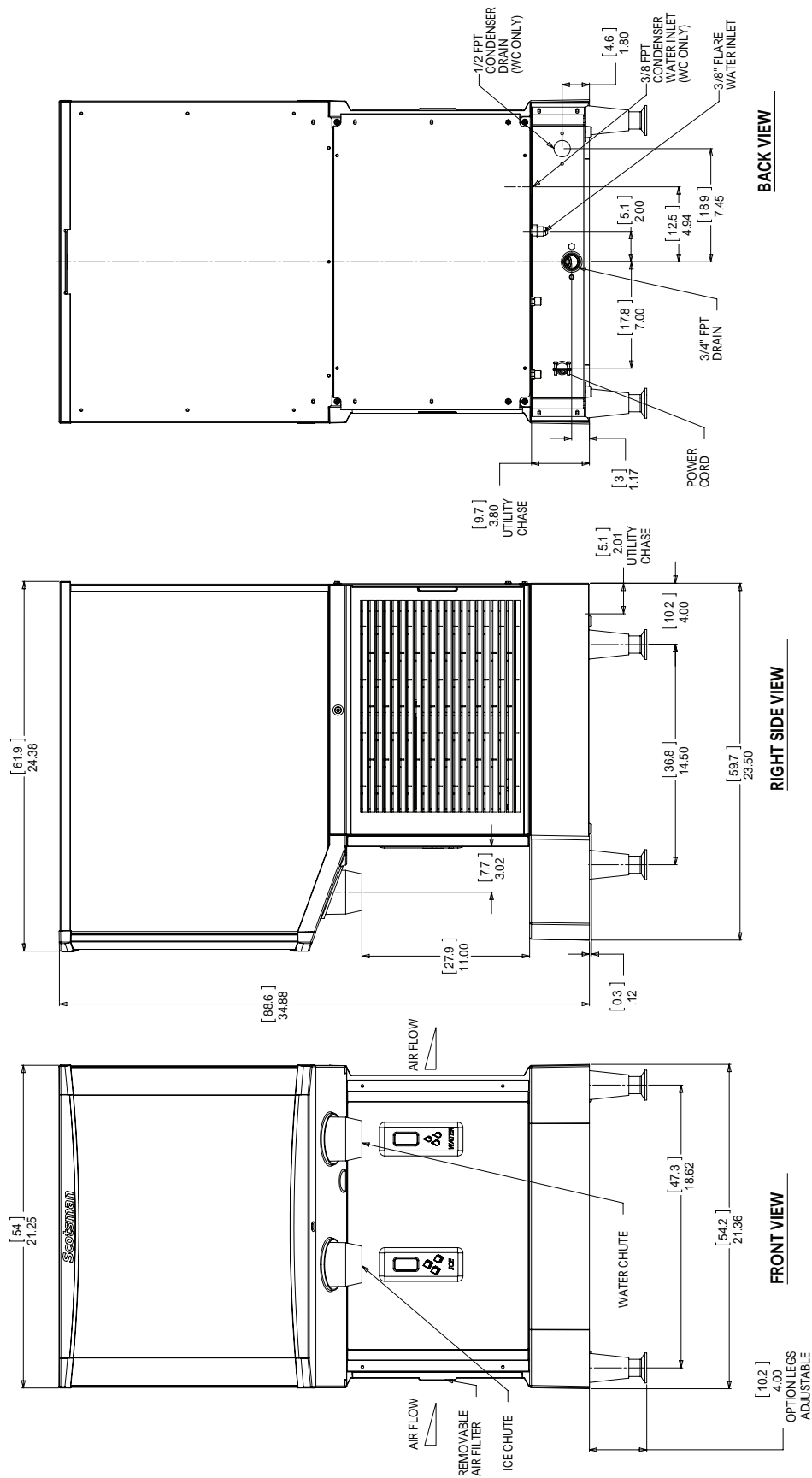

HID312, HID525, HID540

Service Manual

HID540 Cabinet Drawing

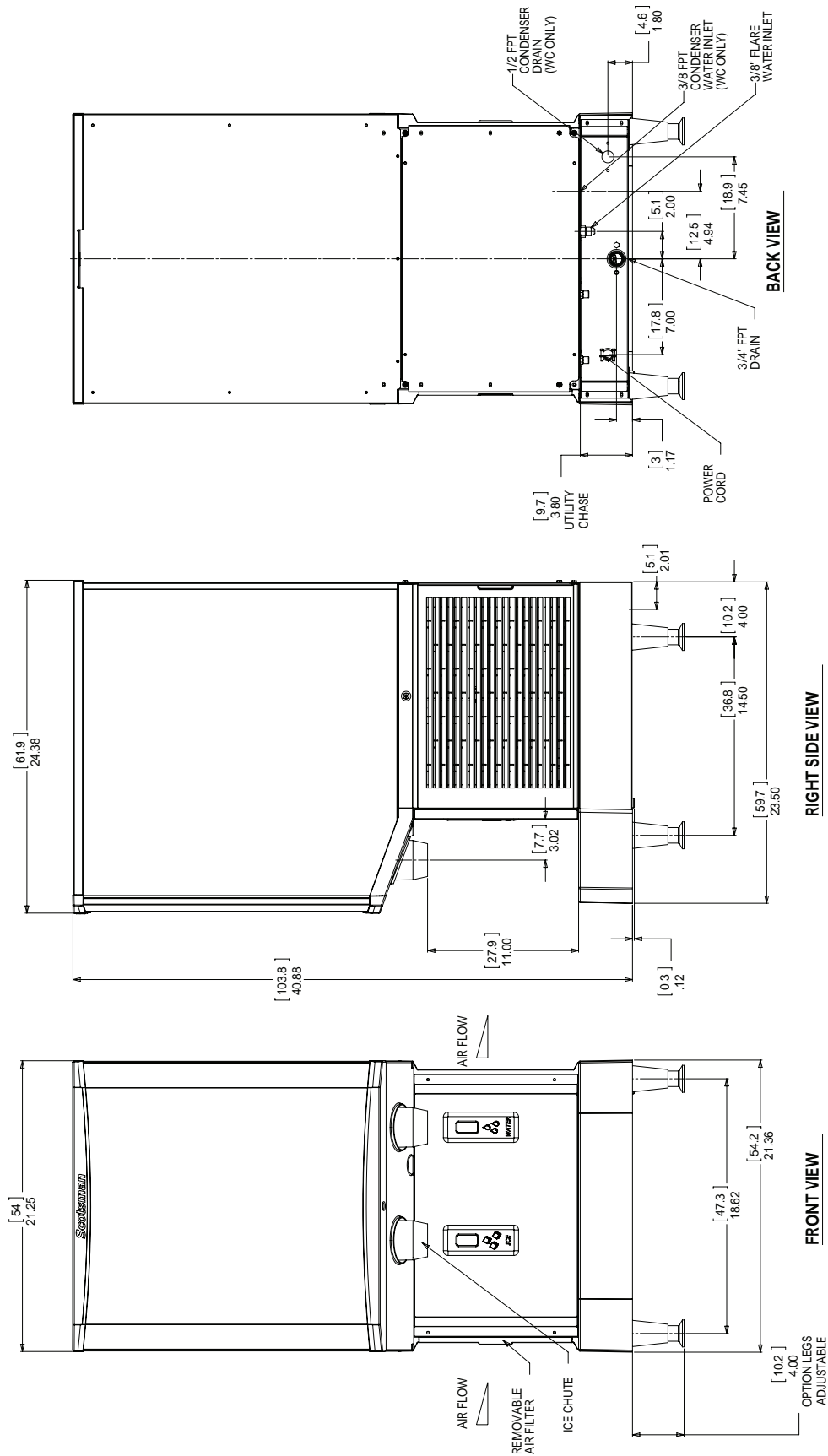

HID312, HID525, HID540

Service Manual

Placement

The location of the equipment should be selected with care. Consideration should be given to allow adequate space on the sides for air cooled models to breathe.

Minimum clearances for air cooled models:

- 6 inches or 15 cm at each side
- 2 inches or 5 cm above, 10" or 25 cm more to allow auger removal when ceiling is fixed.
- 6 inches or 15 cm at the back.

Air cooled models flow air left to right. More space than the minimum at the sides will maximize performance.

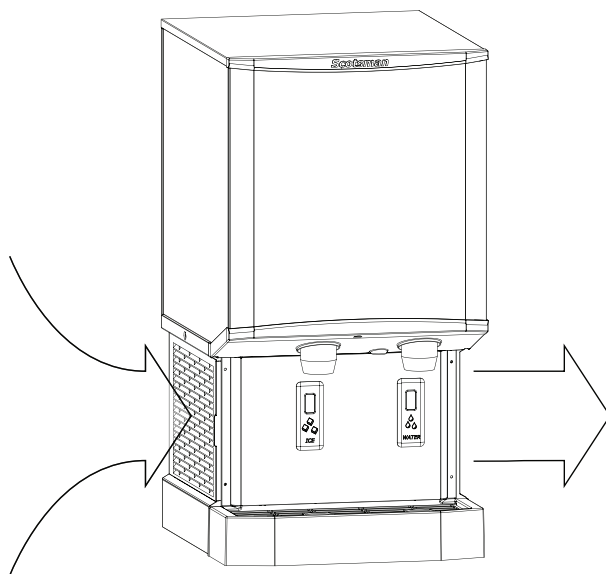

Airflow Direction

The power outlet should be located within the length of the supplied power cord. If placed on a counter, the counter must be strong enough to support the weight of the unit. Space above the cabinet should be allowed for service and maintenance. If legs will be used, allow space for the total cabinet height.

Air cooled models in a small room will require ventilation to exhaust the heat they produce. They also produce some added noise from the fan. Noise sensitive areas should consider water cooled equipment or the machine located where the noise from ice making is not objectionable.

Nearby infrared emitters or a window that allows sunlight to shine on a dispensing sensor may cause the unit to dispense ice or water without a container to trigger it.

Cafeteria applications.

The unit can be placed in a cafeteria line for ice and water. As some users sometimes dispense too much ice, high volume use may require the drip tray to be occasionally cleared of spilled ice.

HID312, HID525, HID540

Service Manual

Counter Installations

Units placed on a counter must either use legs or be sealed to the counter top with food grade sealant per local codes. To avoid disturbing the seal, complete the installation prior to sealing.

Note: Seal Chassis to Counter, do NOT Seal Drip Tray

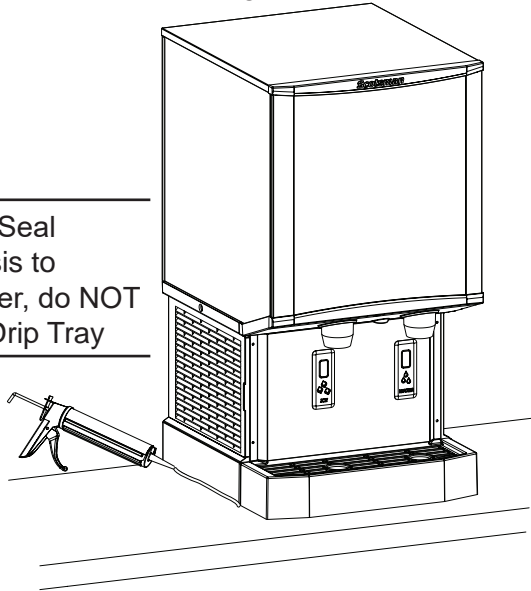

Legs

4" legs are optional for countertop applications. They are not to be used on the HID dispenser when it is placed on a machine stand.

Note: Use only legs of 4" minimum height.

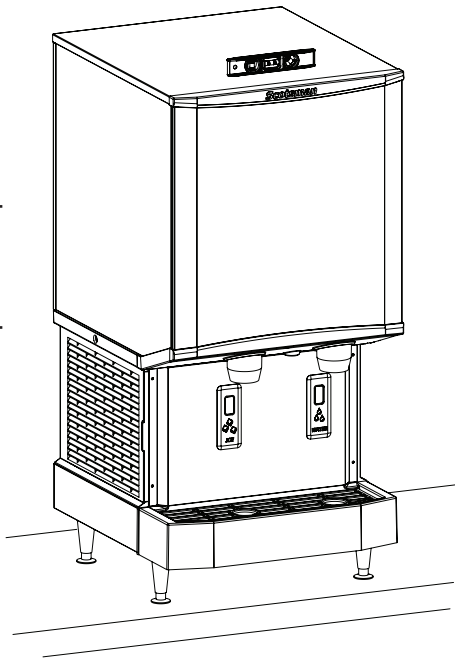

Set Up

The drip tray and cup rest are shipped in place, there is no need to attach or remove them. It is a good idea to remove the front panels and inspect for any loose or rubbing parts prior to installation.

Panel Removal

Remove one screw at bottom front of upper front panel, swing bottom of panel forward and lift off the unit.

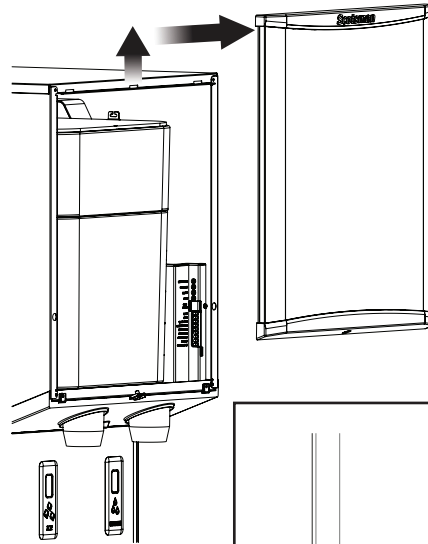

Twist ice and water chutes counterclockwise and pull down to remove.

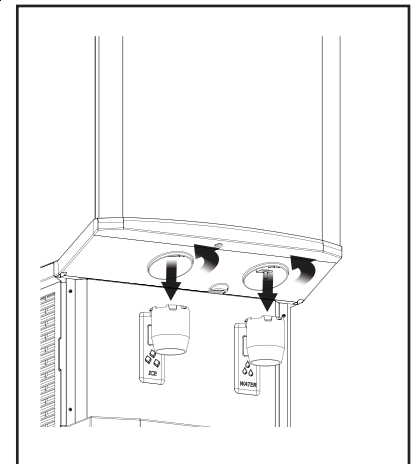

Remove four screws from sides of lower front panel, pull forward slightly and rest it on the drip tray. If needed, unplug sensor connector and separate panel from unit.

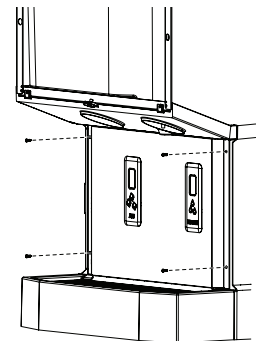

Pre-Start Inspection

Level the cabinet front to back and left to right. Confirm there are no loose or rubbing parts. Return splash panel and chutes to unit.

HID312, HID525, HID540

Service Manual

Differences Between Models

Model	Electrical	Condenser	Cabinet Type	Width in / cm	Height in / cm	Refrigerant / Charge
HID312A-1A	115/60/1	Air	Counter	16 / 41.3	35 / 88.6	R-134a / 12 oz
HID525A-1A	115/60/1	Air	Counter	21 / 54	35 / 88.6	R-404A / 12 oz
HID525W-1A	115/60/1	Water	Counter	21 / 54	35 / 88.6	R-404A / 11 oz
HID540A-1A	115/60/1	Air	Counter	21 / 54	41 / 103.8	R-404A / 12 oz
HID540W-1A	115/60/1	Water	Counter	21 / 54	41 / 103.8	R-404A / 11 oz
HID312AW-1A	115/60/1	Air	Wall Mount	16 / 41.3	35 / 88.6	R-134a / 12 oz
HID525AW-1A	115/60/1	Air	Wall Mount	21 / 54	35 / 88.6	R-404A / 12 oz
HID540AW-1A	115/60/1	Air	Wall Mount	21 / 54	41 / 103.8	R-404A / 12 oz
HID312A-6A	230/50/1	Air	Counter	16 / 41.3	35 / 88.6	R-134a / 12 oz
HID525A-6A	230/50/1	Air	Counter	21 / 54	35 / 88.6	R-404A / 12 oz

Model	Electrical	Condenser	Typical Watts	Auger Motor Amps	Compressor Amps	Compressor Brand / Model
HID312A-1A	115/60/1	Air	415 - 420	1.1 - 1.3	4.1 - 4.3	Embraco
HID525A-1A	115/60/1	Air	816 - 825	1.1 - 1.5	5.7 - 5.9	Copeland
HID525W-1A	115/60/1	Water		1.1 - 1.5	5.7 - 5.9	Copeland
HID540A-1A	115/60/1	Air	816 - 825	1.1 - 1.5	5.7 - 5.9	Copeland
HID540W-1A	115/60/1	Water		1.1 - 1.5	5.7 - 5.9	Copeland
HID312AW-1A	115/60/1	Air	415 - 420	1.1 - 1.3	4.1 - 4.3	Embraco
HID525AW-1A	115/60/1	Air	816 - 825	1.1 - 1.5	5.7 - 5.9	Copeland
HID540AW-1A	115/60/1	Air	816 - 825	1.1 - 1.5	5.7 - 5.9	Copeland
HID312A-6A	230/50/1	Air				Embraco
HID525A-6A	230/50/1	Air				Copeland

Model	Electrical	Condenser	Suction Pressure (PSIG)	Superheat (Degrees F.)	70/50 Discharge Pressure (PSIG)	90/70 Discharge Pressure (PSIG)
HID312A-1A	115/60/1	Air	6 - 8	7 - 10	102 - 109	138 - 145
HID525A-1A	115/60/1	Air	30 - 34	11 - 15	230 - 235	300 - 310
HID525W-1A	115/60/1	Water	30 - 34		245 - 250	245 - 250
HID540A-1A	115/60/1	Air	30 - 34	14 - 15	230 - 235	300 - 310
HID540W-1A	115/60/1	Water			245 - 250	245 - 250
HID312AW-1A	115/60/1	Air	6 - 8	7 - 10	102 - 109	138 - 145
HID525AW-1A	115/60/1	Air				
HID540AW-1A	115/60/1	Air				
HID312A-6A	230/50/1	Air				
HID525A-6A	230/50/1	Air				

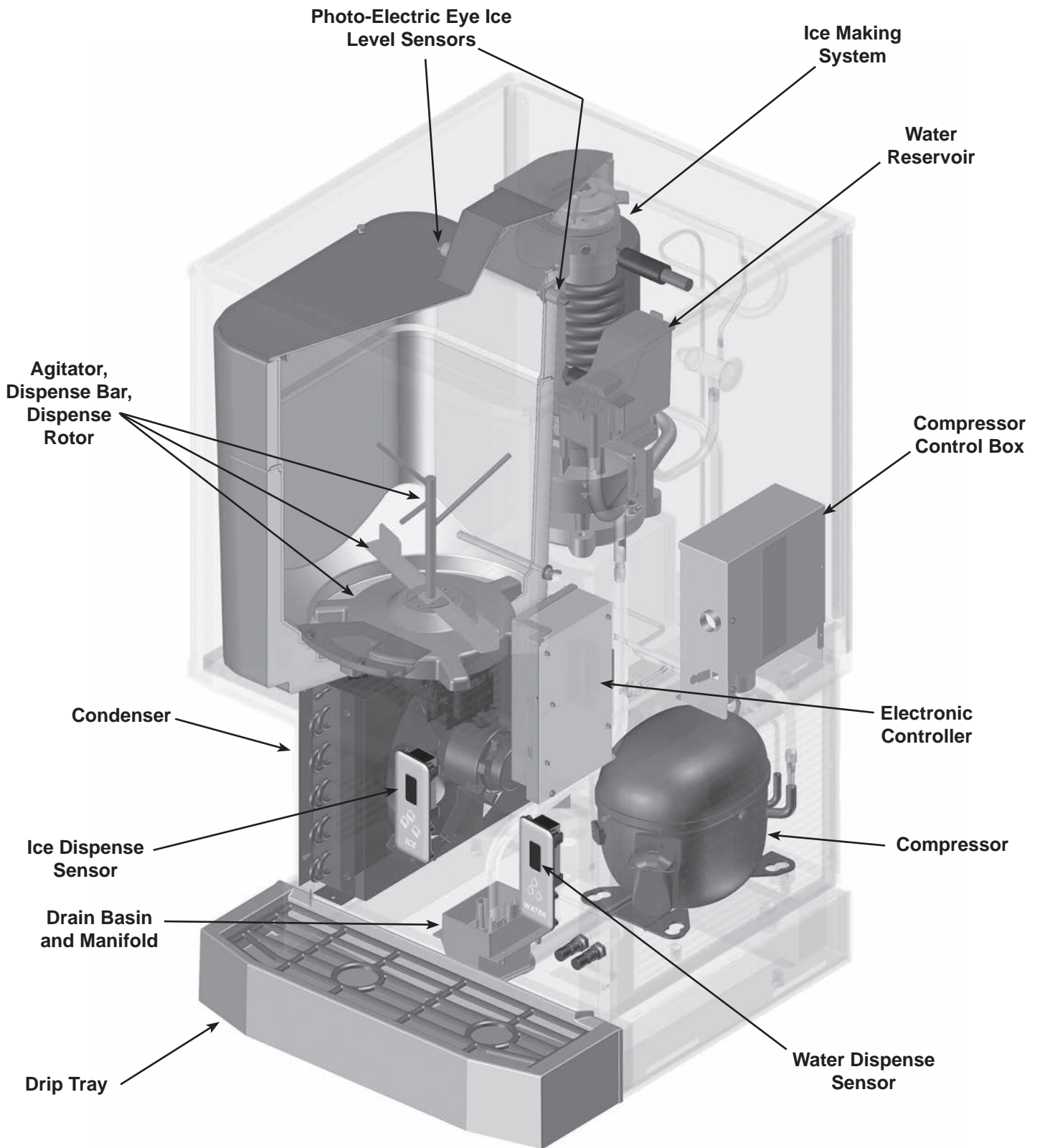

HID312, HID525, HID540

Service Manual

Installation

Installation should be done by an experienced ice machine installer. To locate one, call the number on the back of this manual or go to Scotsman's website www.scotsman-ice.com to identify a local distributor or service company.

The machine will require power, water and drain. Locate the water supply fitting on the lower back of the cabinet and obtain the correct fitting to connect the water supply.

Plumbing Fittings:

- Potable water inlet: 3/8 male flare.
- Cabinet drain: 3/4 FPT.
- Water cooled condenser inlet: 3/8 FPT.
- Water cooled condenser drain: 1/2 FPT

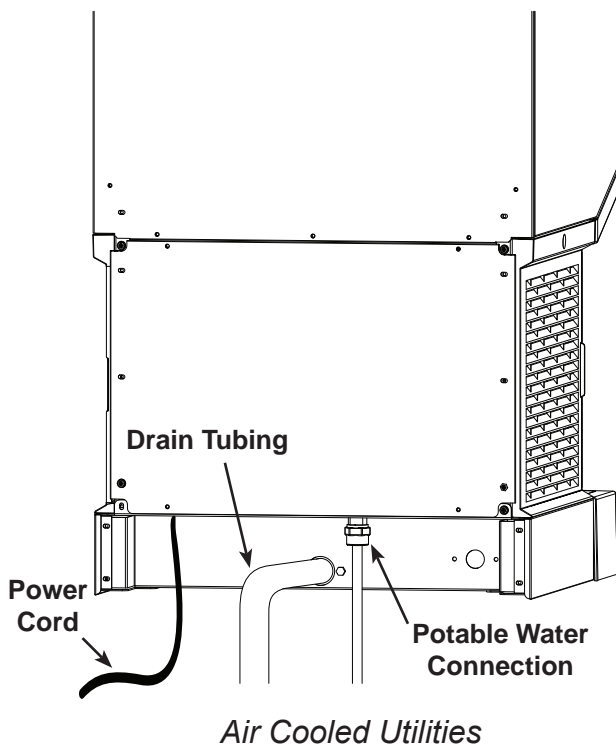

All models:

Connect the potable water supply to the inlet at the bottom back of the unit. 3/8" OD tubing recommended. Water filters may be used but are not required. Note that activated carbon or charcoal water filters are used for taste and odor problems but also take out any chlorine that the local water agency may have added for purification. That can require more frequent sanitization of the equipment.

Connect drain tubing to the central drain fitting at the back of the cabinet. Use 3/4 inch rigid tubing, use

material to meet local codes. The drain basin in the machine will act as an internal vent, no additional vent should be required unless there is a very long horizontal run. Drain tubing must pitch down 1/4 inch per foot to the building drain. Insulation of drain tubing is recommended for most environments.

Water cooled models:

Connect water or coolant supply (if using recirculating system) to the condenser inlet.

Connect drain (or return if a recirculating system) to the condenser drain. Use only rigid tubing. Do not vent this drain tube.

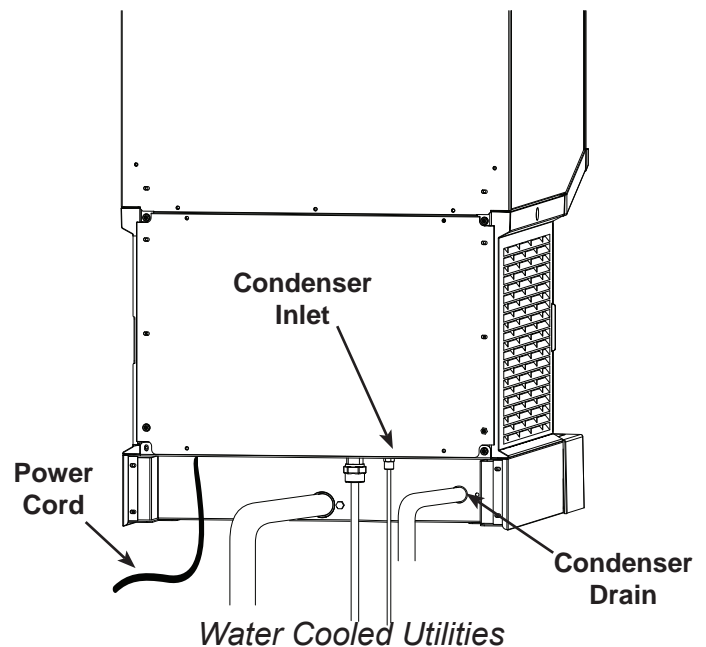

Electrical Supply - 115 volt models

Plug the unit into a dedicated 15 amp outlet. The unit must be the only device on the circuit. Confirm the outlet is properly grounded and is in good condition. Worn outlets should be replaced as they can cause erratic operation of equipment. Do not use an extension cord. Do not cut off the ground plug on the power cord.

Ground fault outlets are not recommended. If ground fault is required a ground fault breaker should be used.

Use the services of a licensed electrician when needed and conform to local and national codes.

Position the unit in its final location.

Level the unit front to back and left to right.

Seal to the countertop as required per local codes.

HID312, HID525, HID540

Service Manual

Start Up

1. Remove upper front panel
2. Open the water hand valve, observe that water enters the water reservoir, fills and then shuts off. Check for leaks. Repair any leaks before going any further.
3. Switch electrical supply on. Lights on controller will flash and then the power light will remain on. The code display will show *0*.
4. Push and release the On/Off button. The machine will start the ice making process. The code display will show *F*. Air cooled models will discharge warm air out the right side, water cooled models will discharge warm (about 110°F.) water out of the condenser drain.
5. In minutes ice will begin to fall into the dispensing bin. Check ice dispensing by holding a container in front of the Touch Free ice sensor (just below the ice delivery spout). Ice should flow from the spout when a container is present, and stop dispensing when the container is removed.
6. Check water dispensing by holding a container in front of the Touch Free water sensor. Water will flow when a container is present and stop when it is removed.
7. Push the On/Off button to switch the machine off.
8. Unplug or disconnect electrical power.
9. Remove the top panel and the top of the ice storage bin. Scoop out any ice in the bin and sanitize the interior of the ice storage bin by wiping it with a locally approved sanitizer or a mixture of 1 ounce of household bleach to 2 gallons of water, allow to air dry.
10. Reconnect electrical power.
11. Push the On/off button to switch the machine on.
12. Replace all covers and panels.
13. Give the owner/user the user manual, instruct him/her in the operation and maintenance requirements of the unit. Make sure they know who to call for service.
14. Fill out the Customer Evaluation and Warranty Registration form, and mail it in to Scotsman or register the unit at Scotsman's website (www.scotsman-ice.com).

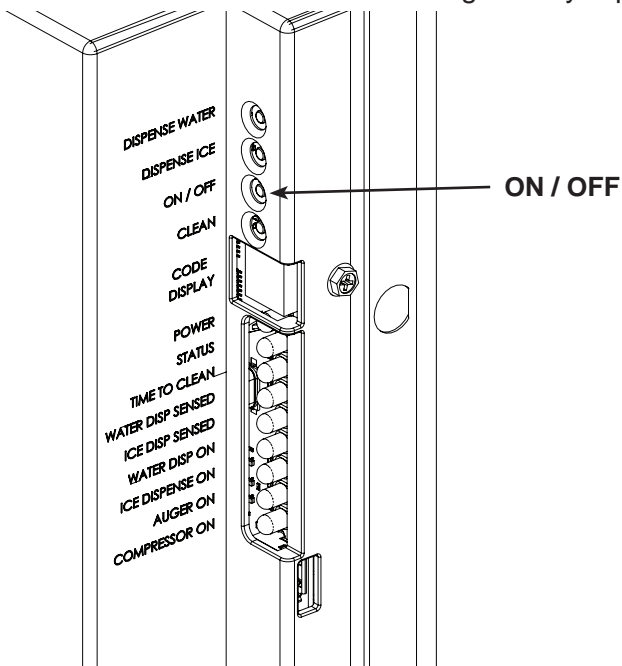

HID312, HID525, HID540

Service Manual

Operation: Ice and Water Vending

During ice making soft ice is compressed thru a die and then broken off into irregular lengths. It will not be clear and, because of melting, when dispensed it will not be uniform in size or shape.

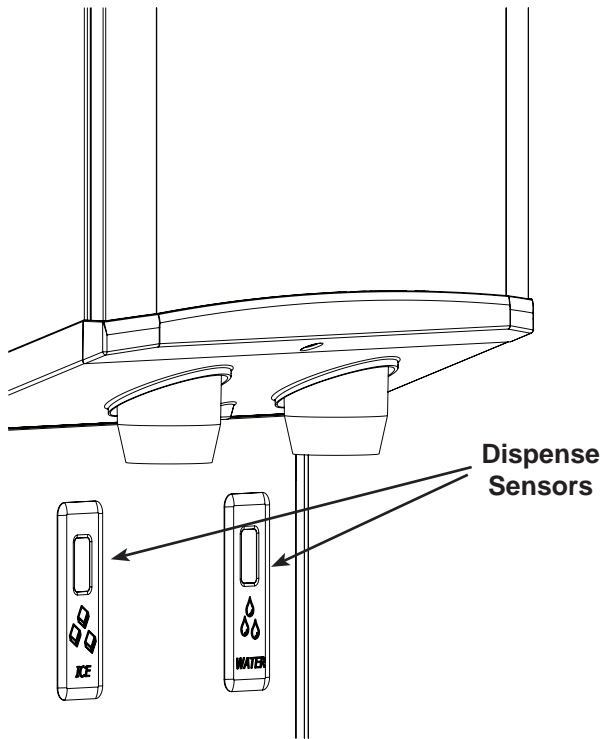

Dispensing takes place when the Touch Free sensor's infrared beam bounces back to the sensor from a container placed directly in front of it.

If the container is in front of the Touch Free sensor on the left side, the ice dispensing rotor will rotate and sweep ice over the ice dispensing chute. Ice will continue to discharge out this chute as long as the rotor is turning. It stops when the rotor stops.

If the user does not remove the container, ice will be dispensed for 24 seconds and then stop.

If the container is in front of the Touch Free sensor on the right side, the inlet water valve will open and water will flow into the container.

If the user does not remove the container water will be dispensed for 20 seconds and then stop.

Note: Water may dispense cloudy and then clear up in the glass. That is normal due to air in the water and is not an indicator of any malfunction.

Other notes:

- An occasional drip may be seen from the ice dispense chute. This is normal and is from ice melting inside the chute. A continuous stream of water from the ice chute indicates a restricted bin drain.
- Clear containers (glass or plastic) may not always activate the dispense sensors. Retry with an opaque container.
- The drip tray is not a sink and cannot tolerate garbage. Coffee and soda should not be discarded into it. Debris like stirring straws that are discarded into the drip tray will likely cause a drain back up and need to be removed as soon as they are found.
- Both dispensing and ice making are disabled when the unit is switched off at the controller.

Splash panel wipe-off. Wiping the splash panel could result in unintended dispensing. To avoid that, a disable button has been provided. It is recessed into the bottom of the chute panel. Push and release it to disable dispensing for 60 seconds.

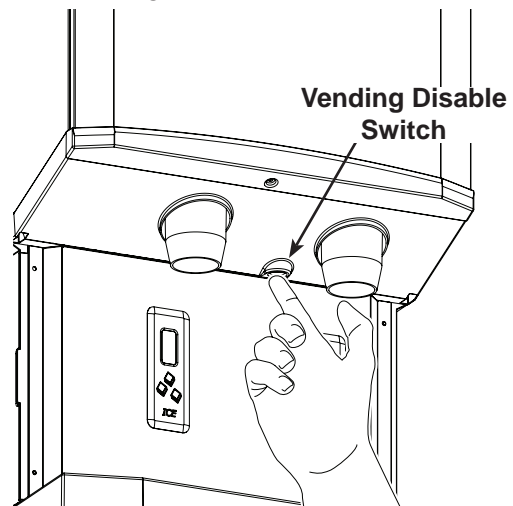

Noise

This is a commercial ice machine. It contains a powerful compressor, heavy duty gear reducer and, if air cooled, a fan that moves a lot of air. It will produce some noise when it is making ice. Every effort was made during its design to minimize the sound level but some is unavoidable.

HID312, HID525, HID540

Service Manual

Controller

All models use the same control system.

The electronic controller operates the compressor (with fan motor), auger drive motor, dispense drive motor and inlet water solenoid valve. It monitors:

- Reservoir water availability
- Storage bin ice level
- Call for ice dispense
- Call for water dispense
- Refrigeration pressure
- Dispense enable / disable
- Auger motor speed
- Auger motor rotation
- Any installed control options

Many of these are used to insure that the machine does not damage itself during use. For example, it is critical that it not attempt to make ice without water, so if the water sensor is dry, the machine will not make ice.

Switches - there are four switches:

- **Dispense water** - to test water dispensing
- **Dispense ice** - to test ice dispensing
- **On/Off** - to switch the machine on or off. Holding it in to shut off will stop ice making immediately.
- **Clean** - to engage the clean mode

Indicators - there are nine LEDs:

- **Power** - Glows when controller has power
- **Status** - Glows when in ice making mode
- **Time to Clean** - Glows when it is time to clean the machine
- **Water Dispense Sensed** - glows when the water dispense sensor has been triggered*
- **Ice Dispensed Sensed** - glows when the ice dispense sensor has been triggered*
- **Water Dispense** - glows when the inlet water solenoid valve has been powered*
- **Ice Dispense** - glows when the ice dispense motor has been powered*
- **Auger** - glows when the auger motor is on
- **Compressor** - glows when the compressor is on

* If blinking the water or ice dispensing time limit has been met.

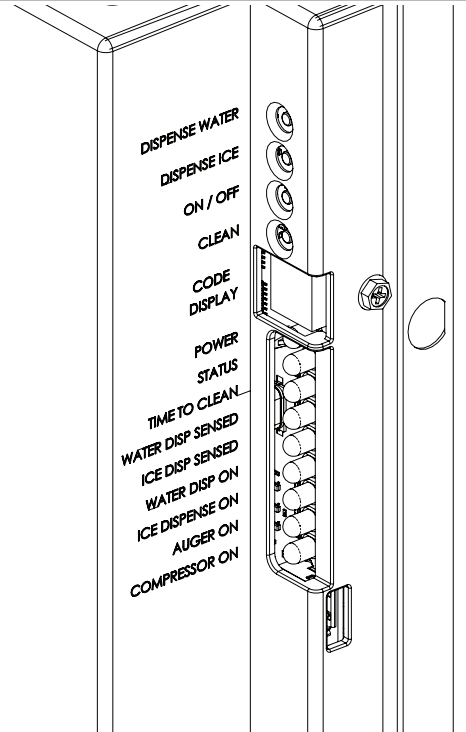

There is also a code display, the codes are:

- O* - - - for off
- F* - - - for ice making
- b* - - - for bin full
- E* - - - for controller error
- C* - - - for clean mode
- d* - - - for test mode
- 1* - - - for auger rotation direction wrong
- 2* - - - for auger speed too slow
- 3* - - - for no water sensed
- 4* - - - for high refrigerant pressure

If a number code is triggered, the controller will stop ice making. A blinking code means it is a temporary condition. Example: A blinking *F* occurs during the ice making restart process; it stops blinking when the compressor starts.

The controller will automatically restart from a water interruption or power interruption or when a refrigerant pressure switch has automatically reset.

To reset the control when it has been manually locked out, Push and release the On/Off button to shut it Off and then Push and release it again to switch it On.

Note: The compressor will not restart for 4 minutes from the time it was shut off.

HID312, HID525, HID540

Service Manual

Controller Functions

The controller has features for the service technician. Some details

- Any auger motor failure is an immediate shut down. Because of the critical nature of that failure there is no auto restart from an auger error.
- An open Water Sensor (dry probes) will stop the machine. Because water can be restored at any time, whenever both Water Sensor probes are wet again AND the compressor has been off for at least two minutes, ice making will restart.
- An open High Pressure switch will stop the machine. Because the pressure switch is an automatic reset, when it closes AND the compressor has been off for at least two minutes, ice making will restart.
- Fault Code View: Push and HOLD the **vend disable button** *see page 13 for location then push and hold the **on/off button** for 3 seconds or until Status light is on. Release both. Pushing Clean will cycle thru the available codes, the total number of codes stored is 30.
- Clear codes: Push and HOLD the **vend disable button** then push and hold the **Clean button** for about 3 seconds. The display code will blink 3 times. Release both.
- The compressor will not restart until it has been off for at least 2 minutes.
- There is a Test Mode. The Test Mode operates each load in sequence to confirm that it is being powered by the controller.

To start Test Mode: Push and HOLD the ON/OFF button; at the same time, push and HOLD the CLEAN button. When a “d” appears in the code display, release the buttons, the test mode will begin.

Time (seconds)	On	Off
0	Compressor	Auger Gear Motor, Water Disp, Ice Disp
10	Compressor and Auger Gear Motor	Water Disp, Ice Disp
20	Auger Gear Motor	Compressor, Water Disp, Ice Disp
30	Water Dispense	Auger Gear Motor, Compressor, Ice Disp
35	Ice Dispense	Auger Gear Motor, Compressor, Water Disp
40	None	All – Test Complete

- The Time to Clean indicator light glows when 6 months of power up time have elapsed. When it is on it does NOT stop ice making. It is cleared and reset when the Cleaning process has been completed.
- The Cleaning process, described in detail in the Maintenance section, is initiated by a press of the Clean button. The auger motor will be operating during the entire Clean mode. No ice will be made. The scale is dissolved by the action of the scale remover and the auger’s motion.
- Pushing the Disable switch closes contacts of the switch, signalling the controller to ignore the dispense sensor’s signals for 60 seconds.
- USB firmware updates may become available. To update the unit must be in Test Mode and then a USB stick with ONLY the update on it is inserted into the USB connector. L will be displayed during the Loading process. After a few seconds the top five LEDs begin scrolling up for about 75 seconds then the LEDs start scrolling down for about 20 seconds. At the end “0” is displayed. Unplug the USB drive.

Note: If during the update process the display flashes between “L” and “F” that means that the Load Failed. If that happens, unplug the USB drive, then power cycle the control board. If “0” is not displayed, press the On/Off button. The controller will revert to the original firmware.

HID312, HID525, HID540

Service Manual

Maintenance and Cleaning

There are five areas of maintenance:

1. Drip tray and drain system
2. Air cooled condenser filter and condenser
3. Ice dispense bin and rotor
4. Photo eye ice level control
5. Ice making water system

Drip Tray

It is important to keep the drip tray clean of trash. Remove any as soon as it is noticed. Pour hot water into the tray on a regular basis to keep the drain open.

Over time the drip tray and cup rest may become coated with scale or dirt. It can be removed to be scrubbed at a wash sink.

1. Remove upper front panel.
2. Push in vend disable switch.

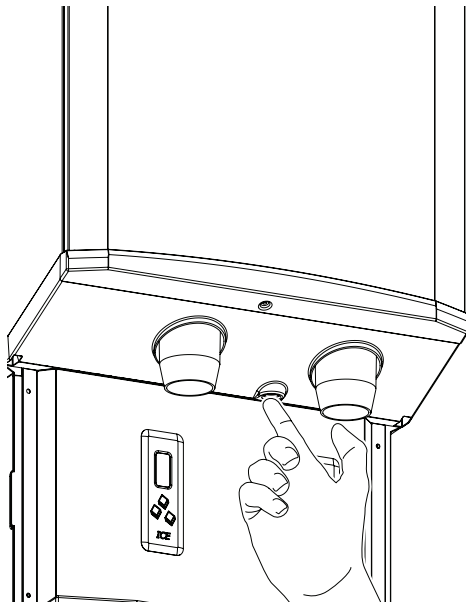

3. Twist dispense chutes clockwise and pull down to remove.

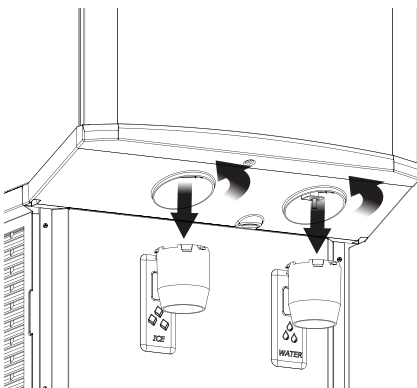

4. Remove screws holding lower front panel to unit and unplug lower panel sensors at the harness connection. Set panels aside.

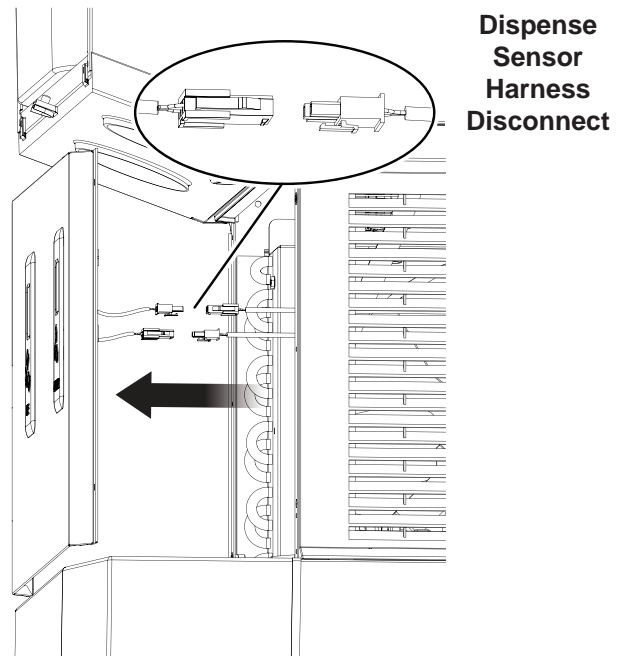

5. Shut the machine off.
6. Pull the sink forward to disconnect it from the drain. Plug the drain fitting with a cloth to keep it from leaking while the drip tray is being cleaned.

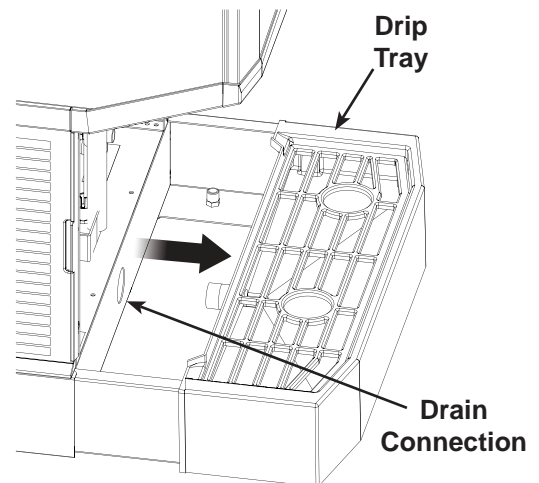

7. Wash out the drip tray and dispense chutes. Use ice machine scale remover if needed to dissolve scale.
8. Reverse to reassemble. Be sure drip tray is pushed back fully into place. Insert chutes and rotate CCW until they snap into place and stop.

HID312, HID525, HID540

Service Manual

Air filter

The air filter on the left side of the cabinet will capture significant dust and lint during operation. As the dirt builds up it begins to restrict air flow and causes the refrigeration system to work longer to make ice. Clean the air filter regularly.

To remove, pull it forward from the louvers. Do not leave it out for extended periods of time.

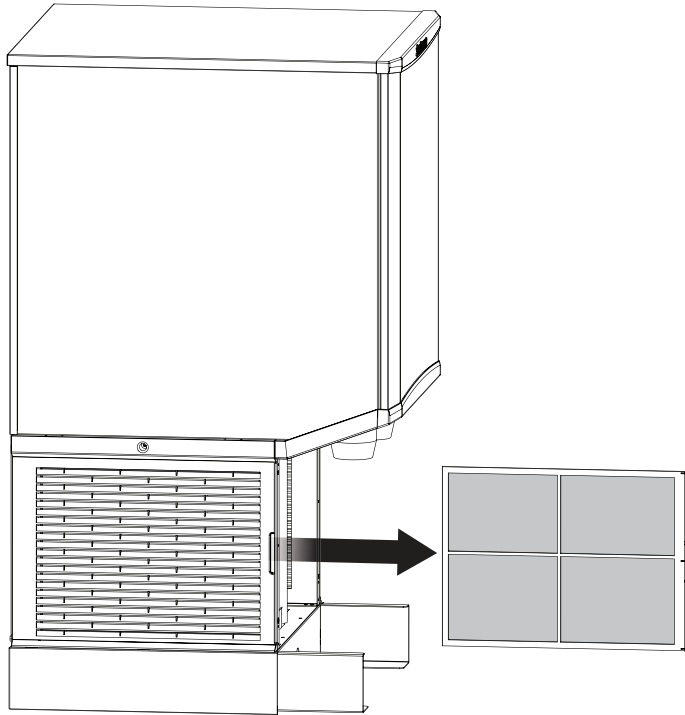

To clean, wash it at a utility sink. Return it to the unit when clean.

Condenser.

The condenser fins may need cleaning too. Remove the left side air grill and brush any lint and dirt off the surface of the condenser. Vacuum any remaining dirt. Do not damage the fins of the condenser during cleaning.

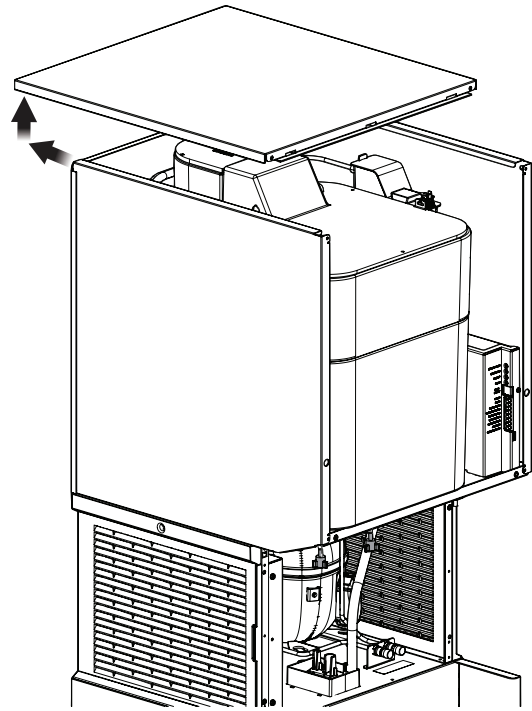

Remove Top Panel

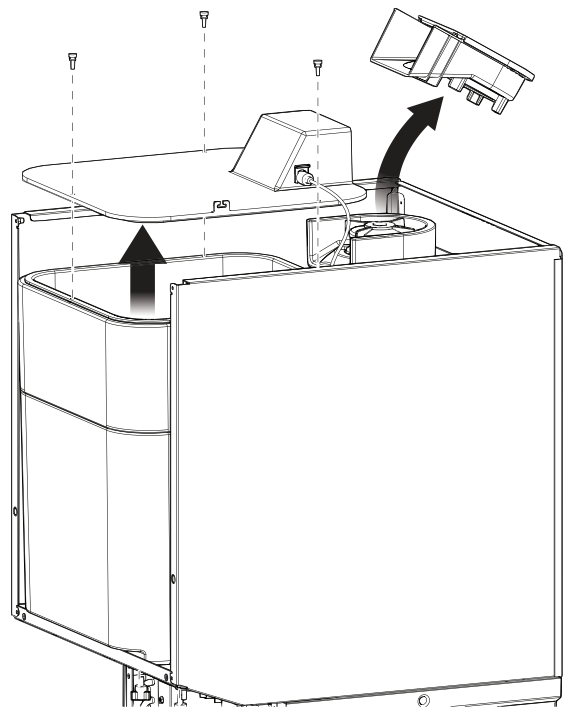

Remove Bin Cover and Ice Delivery Chute

HID312, HID525, HID540

Service Manual

Maintenance and Cleaning - Dispensing Bin Components

The ice storage bin and rotor must be cleaned and sanitized on a regular basis, at a minimum when the ice making system is cleaned. Hand tools and hand protection like rubber gloves are recommended for this procedure.

Note: Some steps overlap with the procedure on the next page. This procedure can be independent of the ice making system cleaning or can be part of it.

Bin Cleaning Procedure

1. Remove upper front panel.
2. Remove top panel.
3. Shut machine off.
4. Vend or melt out all ice.

Note: Only add 16 oz or 1/2 liter water to the bin at a time, as excess water will drain out the spout.

5. Disconnect ice level control at harness.

CAUTION	
Moving parts hazard. Risk of personal injury. Disconnect electrical power before proceeding.	

6. Unplug or disconnect unit from electrical power.
7. Remove ice storage bin cover, set aside.
8. Remove agitator (rotate CCW), set aside.
9. Remove 2 thumbscrews & chute cover, set aside.

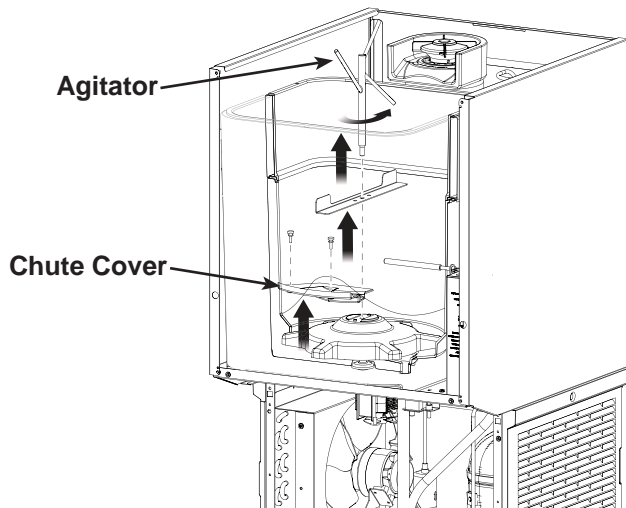

10. Lift up and remove dispense rotor, set aside.

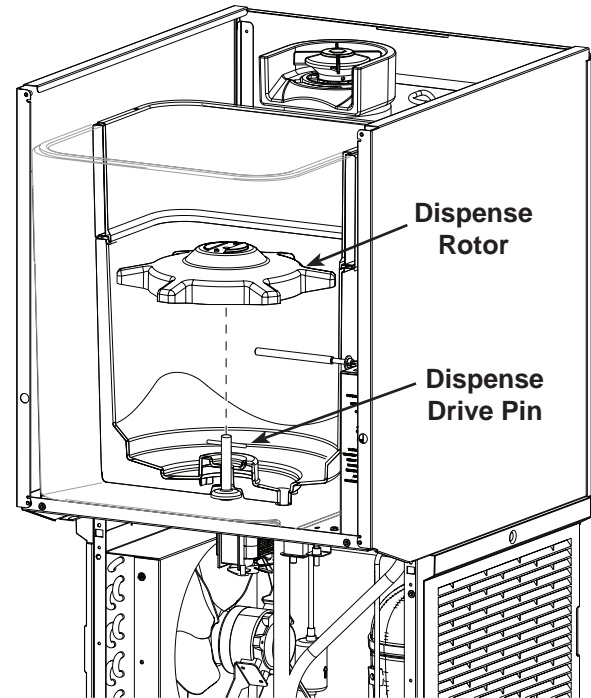

11. Mix a solution of ice machine scale remover, such as Scotsman Clear 1 and potable water per the directions supplied with the scale remover.
12. Use a clean cloth and wash all the interior surfaces of the bin and the bin cover, agitator bar, chute cover and dispense rotor with the ice machine scale remover solution. Rinse with clear water.
13. Mix a 2 gallon or 7.5 liter solution of locally approved sanitizer. A possible sanitizer solution is one packet of Stera Sheen Green Label and 2 gallons or 7.5 liters of warm potable water.
14. Use a new clean cloth and wash all the interior surfaces of the bin and the bin cover, agitator bar, chute cover and dispense rotor with the sanitizer solution.
15. Return all parts to their original positions and secure them with their original fasteners.
16. Reconnect electrical power and restart the machine.

HID312, HID525, HID540

Service Manual

Ice level controls

Clean if the controller indicates bin full and there is no ice between the sensors.

1. Remove top front and top panels.
2. Shut machine off.
3. Disconnect ice level controls at connector.
4. Remove 3 screws and ice storage bin cover.
5. Pull each sensor grommet clip up and off.

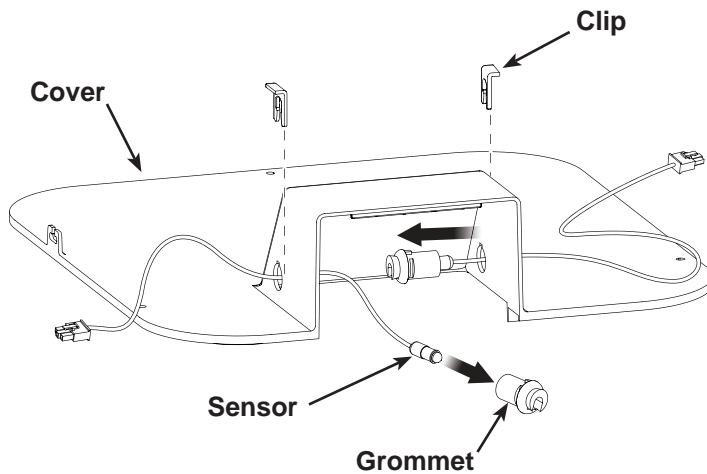

6. Push grommets out of bin top.
7. Pull each sensor out of its rubber grommet. Pull on the part closest to the grommet, not the wire.
8. Wipe the sensor lenses clean with a soft, clean cloth. Caution - do not scratch the lens. If there is mineral scale on the lens, ice machine scale remover will be needed to wipe them clean.
9. Return each sensor to a grommet, push it in until it snaps into place.
10. Reverse the rest of the steps to reassemble.

HID312, HID525, HID540

Service Manual

Dispensing Bin

The dispensing bin may be removed for cleaning or to provide service access to other components.

1. Go thru steps 1 thru 10 of the Bin Cleaning Procedure above.
2. Remove chute cover.
3. Remove ice sweep and ice discharge chute.

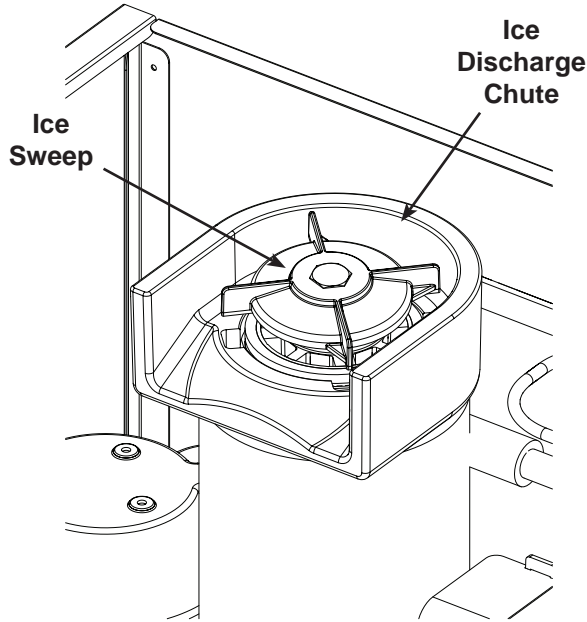

4. Remove dispense motor drive pin.

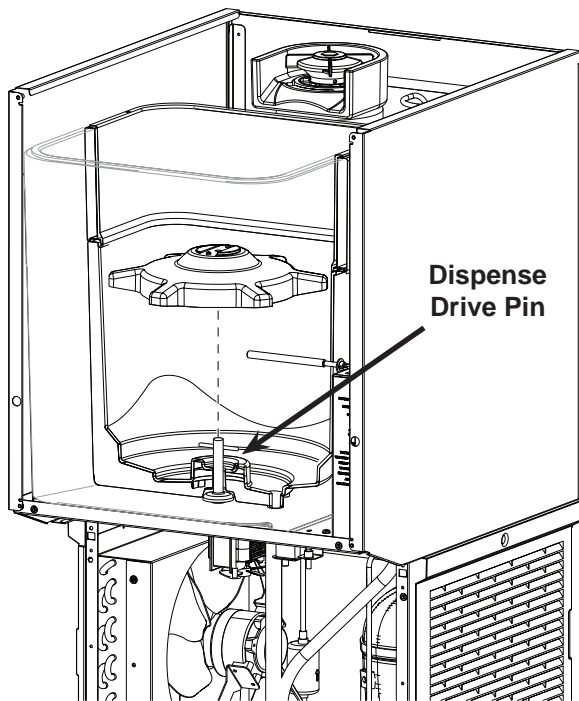

5. Twist and remove the water and ice dispense chutes.

6. Remove the chute mounting panel.

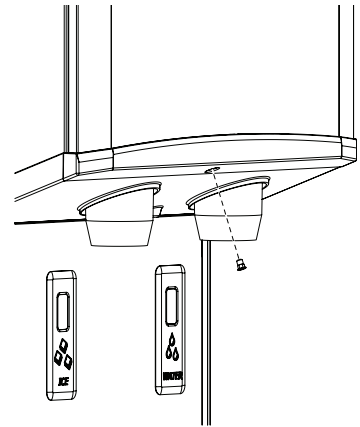

7. Remove splash panel, disconnect sensors from harness and set panel aside.

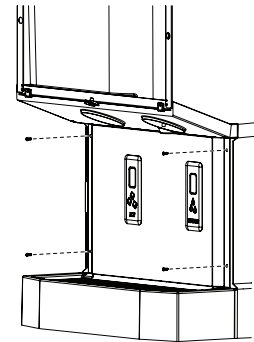

8. Locate two plastic knob bolts under the bin. Remove them.

9. Locate bin drain and disconnect it from bin fitting.

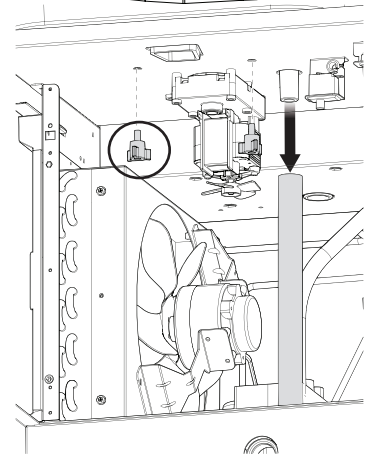

10. Lift the bin up and off the chassis. Clean as needed.

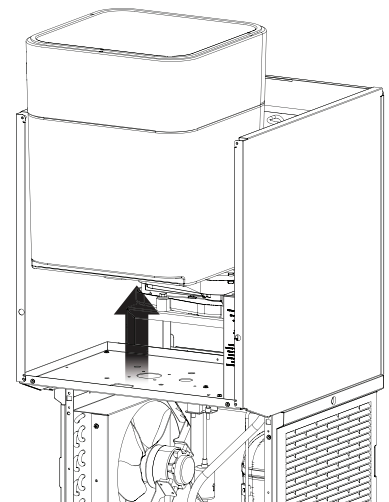

HID312, HID525, HID540

Service Manual

Ice Making and Ice Dispensing System Cleaning Instructions

Hand tools, cleaning supplies and hand protection are recommended for this procedure.

Frequency: Recommended minimum time between cleanings is 6 months. To aid in determining if the machine has not been cleaned in 6 months, a Time To Clean light will glow after 6 months of power up time. Cleaning the machine with the following process will reset that light and the timer that controls it. More frequent cleanings may be required based on the mineral content of the water, run time and potential airborne contamination.

1. Remove both front panels.
2. Push On/Off button to shut ice making off.
3. Shut water supply off.
4. Drain water from ice making system by pulling reservoir drain hose from plug at drain basin and return to plug when drained.

Note: Drain into drain basin in base of unit. Sink must be attached to unit throughout this process.

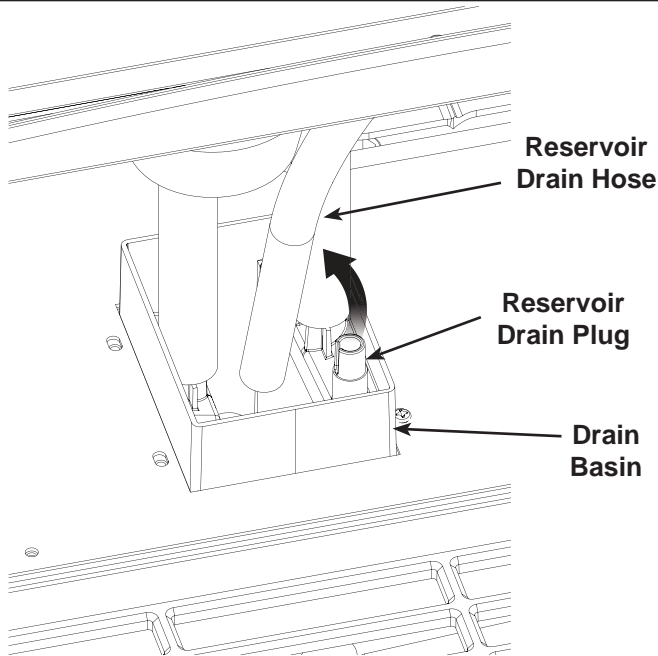

5. Remove reservoir cover and fill with hot (110-120 degree F.) water, wait 2 minutes and drain water from ice making system by pulling reservoir drain hose from plug and return hose to plug when drained.
6. Mix a solution of 16 oz or 1/2 liter of Scotsman Clear 1 ice machine scale remover and 16 oz or 1/2 liter of clean, potable water.

7. Loosen thumb screw holding water reservoir to post.
8. Lift water reservoir to the top of the post and re-secure with the thumb screw.
9. Remove cover from water reservoir.

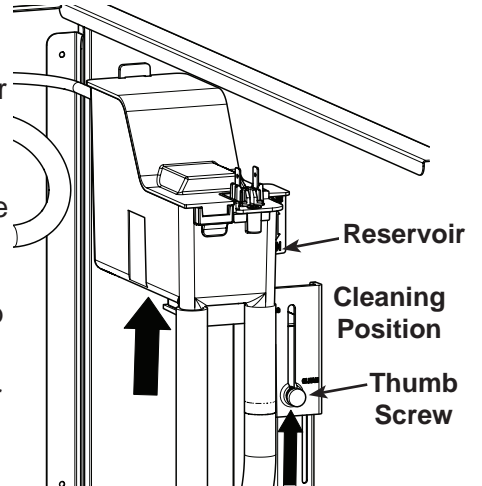

10. Vend all ice from dispenser.

CAUTION	<p>A black silhouette of a hand is shown being struck by a gear. The gear has a curved arrow around it, indicating rotation.</p>
Moving parts hazard. Risk of personal injury. Disconnect electrical power before proceeding.	

11. Remove dispense bin cover.
12. Remove ice discharge chute cover from top of ice making system.
13. Pour cleaning solution into reservoir. Caution: solution is highly acidic. Use rubber gloves and Do Not Spill.

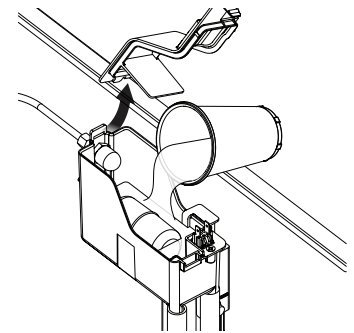

CAUTION	Scotsman Ice Machine Cleaner contains acids. These compounds may cause burns.
<p>A black silhouette of a hand is shown being splashed with liquid from a test tube. The liquid is depicted as a spray of dots.</p>	If swallowed, DO NOT induce vomiting. Give large amounts of water or milk. Call Physician immediately. In case of external contact, flush with water.
	KEEP OUT OF THE REACH OF CHILDREN

HID312, HID525, HID540

Service Manual

14. Push the Clean button. The unit will operate the auger motor for 30 minutes and then stop.

Note: Stop at any time by pushing the On/Off button.

15. Disconnect unit from electrical power.
16. Drain the scale remover solution from the water system by pulling the reservoir drain hose from its plug and return it to the plug when drained.
17. Pour 24 ounces or .7 liters of clean, potable water into the reservoir.
18. Drain the water from the water system by pulling the reservoir drain hose from its plug and return it to the plug when drained.
19. Mix a solution of 4 ounces or 118 cc of ice machine scale remover and 16 oz or 1/2 liter of potable water. Use this scale remover solution to washout the water reservoir cover, ice discharge chute, ice chute cover, ice delivery chute, storage bin cover and inside of the ice storage bin. Also wash the sink /drip tray and grill with this solution. Pour half down the bin drain and the rest into the sink / drip tray to flush out their drains.

Sanitize now.

20. Mix a 2 gallon or 7.5 liter solution of sanitizer. A recommended sanitizer solution is one 2 oz. packet of Stera Sheen Green Label and 2 gallons or 7.5 liters of warm potable water, or an equivalent sanitizer at a concentration of 100 ppm.
21. Pour the sanitizer solution into the reservoir until it is full (level with the molded line on the side).
22. Reconnect electrical power.
23. Push the On/Off button to make ice for 10 minutes. Add more sanitizer to the reservoir to keep it full while making ice.
24. Push the On/off button to stop making ice.
25. Disconnect electrical power.
26. Remove the ice outlet cover, dispense rotor and ice dispenser agitator from the bin. Wash them with the sanitizer solution.
27. Wash all inside surfaces of the ice storage bin and ice discharge chute with the sanitizer solution.
28. Wash the ice discharge chute cover, ice sweep, metal area below the ice sweep and ice dispense chute with the sanitizer solution.
29. Wash the sink / drip tray and grill with the sanitizer solution. Pour remaining sanitizer into the bin and sink. Do not overfill bin.

30. Drain sanitizer from ice making system by pulling reservoir drain hose from plug and return hose to plug when drained.
31. Loosen thumb screw holding water reservoir to post and lower the water reservoir to the top of the slot, retighten thumb screw.
32. Return the chute cover, dispense rotor and agitator to the inside of the storage bin. Secure with the original fasteners.
33. Return the ice dispense chute and water reservoir cover to their original positions and secure them with their original fasteners.
34. Reconnect water and electrical power to the machine.
35. Push the On / Off button to restart ice making.
36. Operate machine for 5 minutes and then push the On / Off button to stop ice making.
37. Pour 16 oz or 1/2 liter of warm potable water into the bin. Repeat until the ice has been melted.
38. Return the dispense bin cover to the machine and secure with the original screws.
39. Push the On / Off button to resume ice making.
40. Return all panels to their normal positions and secure with the original screws.

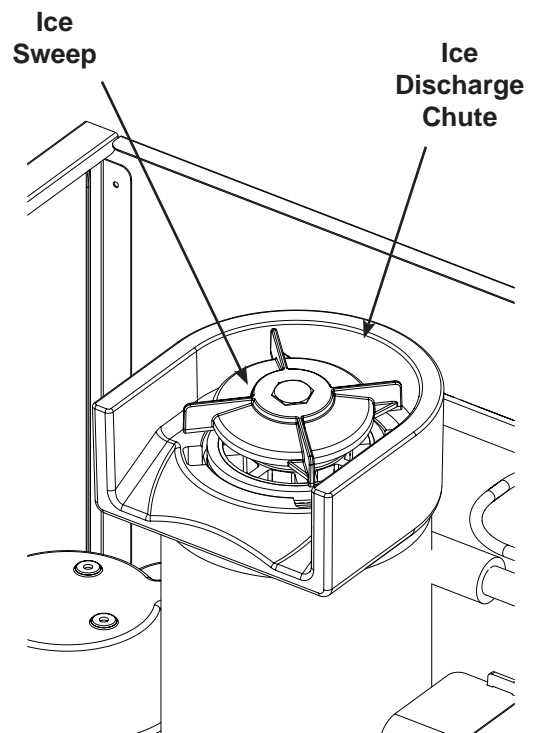

HID312, HID525, HID540

Service Manual

Other Maintenance

The auger in the ice making system is centered by bearings at the top and bottom. It is also sealed from leaking by a water seal at the bottom.

The bearings are permanently lubricated and need no maintenance. They can be visually checked for obvious wear or damage but there is no need to add lubrication.

Auger motor bearings and the gear reducer are also permanently lubricated and need no maintenance.

The bottom of the ice making system should be checked for water leaks. Water draining from the bottom is an indication of a water seal leak. Immediate repair is required when a water seal leak is discovered.

Caution: Moving parts hazard. Do not touch the rotating shaft at any time.

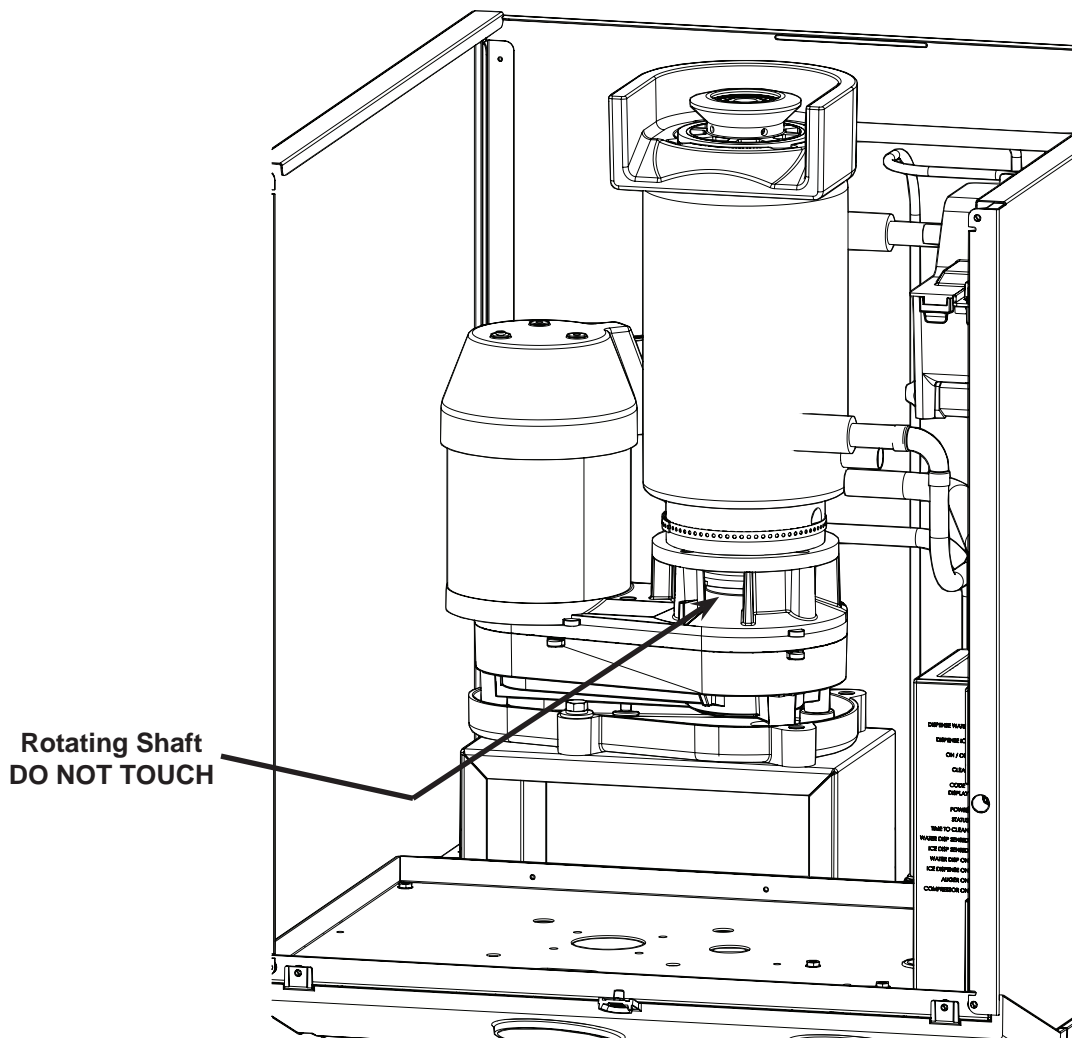
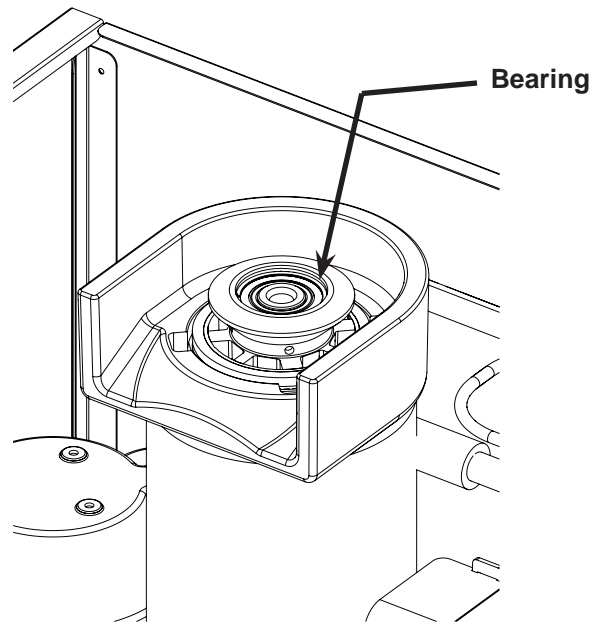

HID312, HID525, HID540

Service Manual

Basic Troubleshooting

Symptom	Possible Cause	Probable Correction
No ice is dispensed	No ice in bin	Unit in Off mode. Remove upper front panel and check controller code, push On/Off button to restart.
		No water to unit. Controller shows code 3. Restore water supply.
		No power to unit, power light on controller is off. Restore power.
		High pressure control opened. Controller shows code 4, water interrupted to water cooled model. Restore water and reset controller.
		Ice level control sensing full bin falsely. Controller shows b. Clean ice level control sensors.
No water is dispensed	Dispense motor not turning	Remove upper front panel, check controller indicator lights. Hold container in front of sensor, does the Ice Dispense Sensed light glow? If no, sensor is not detecting the container. If yes, does the Ice Dispense light glow? If yes, push Dispense Ice button. Does the motor activate? If yes, go to next row. If no, check for voltage at motor. If no voltage, replace controller. If voltage at motor, replace motor.
	Dispense motor working, but ice in bin not moving	Agitator or rotor not turning, remove all ice and inspect for damage to agitator and rotor.
No water is dispensed	No water to unit.	Restore water.
	Water valve not opening	Remove upper front panel, check controller indicator lights. Hold container in front of sensor, does the Water Dispense Sensed light glow? If no, sensor is not detecting the container. If yes, does the Water Dispense light glow? If yes, push Dispense Water button. Does the water valve activate? If no, check for voltage at valve. If no voltage, replace controller. If voltage at valve, replace valve.
Water drips from spout	May be normal	A few drops per minute is normal.
	Bin drain may be plugged.	Check bin drain tube at basin.
Dispensed water is cloudy, but clears up in a few minutes	Air in the water	This is normal and can vary depending upon how much air is in the water. May be improved by lowering water pressure to the unit.
Water leak near front	Drip tray not in position	Confirm drip tray is pushed all the way back and touching the base.
Water filling drip tray	Main drain plugged	Remove splash panel and inspect basin for standing water. Clear drain to and from basin.

Symptom	Possible Cause	Probable Correction
No ice in bin	Auger motor not operating	Open windings. Check motor windings and replace if open.
		Gear reducer seized, replace gear reducer.
		Auger bearings seized, replace bearings and seal
		No power to auger motor, Auger light is ON. Replace controller.
		Code 2 in controller. Check that sensor rotates with motor and isn't loose. Tighten screw if loose.
		Code 1 in controller, replace auger motor.
	Compressor not operating	Contactor coil is open, check and replace if needed.
		Compressor hot and overheated, check start relay and start capacitor
		No power to compressor or contactor coil. Compressor light is ON. Replace controller.
		Compressor at room temperature, will not start. Check windings. If open, replace compressor. If not open, check/replace start relay and start capacitor.
Compressor operating, auger turning, no ice is made	Check refrigeration system, TXV may be set to too much superheat or the system is low on refrigerant.	
Excessive noise	Tubing contact	Check for tubes rattling and panels not tight
	Fan blade out of balance	Replace fan blade
	Compressor noisy	Replace compressor
Moaning noise when making ice	Water seal being compressed	Gear reducer bearing failure, replace gear reducer
Dispense motor not turning	No voltage to it	Check dispense light, if on there should be voltage. If none, replace motor.
	Wrong voltage motor	Check motor label, install correct motor.
Dispense motor working, but ice in bin not moving	Broken ice agitator	Replace and check for mechanical cause for breakage
	Broken drive pin	Replace and check for worn hole in dispense motor shaft
Too much ice in drip tray	Users are taking ice and dumping it	Glass size too small, use larger glass.
Water leak near front	Drip tray not in position, hard to push all the way in	Add small amount of food grade lube to the drip tray drain stub or o-ring in drain fitting.
Glass does not trigger dispense light	Glass is too clear	Confirm by testing dispense with hand behind glass.

HID312, HID525, HID540

Service Manual

Controller Diagnostics

Code or Light Action	Probable Cause	Suggested Action
<i>0</i>	Unit manually switched off	If desired, switch unit on.
<i>F</i>	Freeze mode	None, unit is making ice.
<i>b</i>	Bin sensors sense bin full	Check if bin is full.
<i>E</i>	Corrupted memory	Replace controller
<i>C</i>	Clean mode	Continue clean mode
<i>d</i>	Test mode	None, allow unit to finish test mode.
<i>1</i>	Auger motor rotated auger backwards.	Check capacitor, rotation sensor and rotation harness.
<i>2</i>	Auger motor stalled or operating slowly	Clean ice making system and retry. If unit shuts off again right after a reset, magnet rotor on motor shaft may be loose.
<i>3</i>	No water in reservoir	Restore water. If there is water, is it too pure? Are sensor wires connected?
<i>4</i>	High pressure cut out open	Check fan motor on air cooled or water supply on water cooled.
Water dispense sensed light blinking	Container positioned in front of water dispense sensor for more than 24 seconds	Normal, controller has a time limit for dispensing. Remove container.
Water dispense light blinking		
Ice dispense sensed light blinking		
Ice dispense light blinking		
Status light is on	Unit is in ice making mode	Normal, may not be making ice if bin is full
Time to Clean light is on	Unit has not been cleaned for at least 6 months	Clean unit
Water Dispensed Sensed light is on	A container is in front of the sensor	Normal during water dispensing
Ice Dispensed Sensed light is on	A container is in front of the sensor	Normal during ice dispensing
Water Dispense light is on	Water solenoid has been activated	Normal during water dispensing
Ice Dispense light is on	Bin drive motor has been activated	Normal during ice dispensing
Auger light is on	Auger motor is active	Normal when making ice
Compressor light is on	Compressor is active	Normal when making ice

Dispensing Sensors

Remove upper front panel, check controller indicator lights.

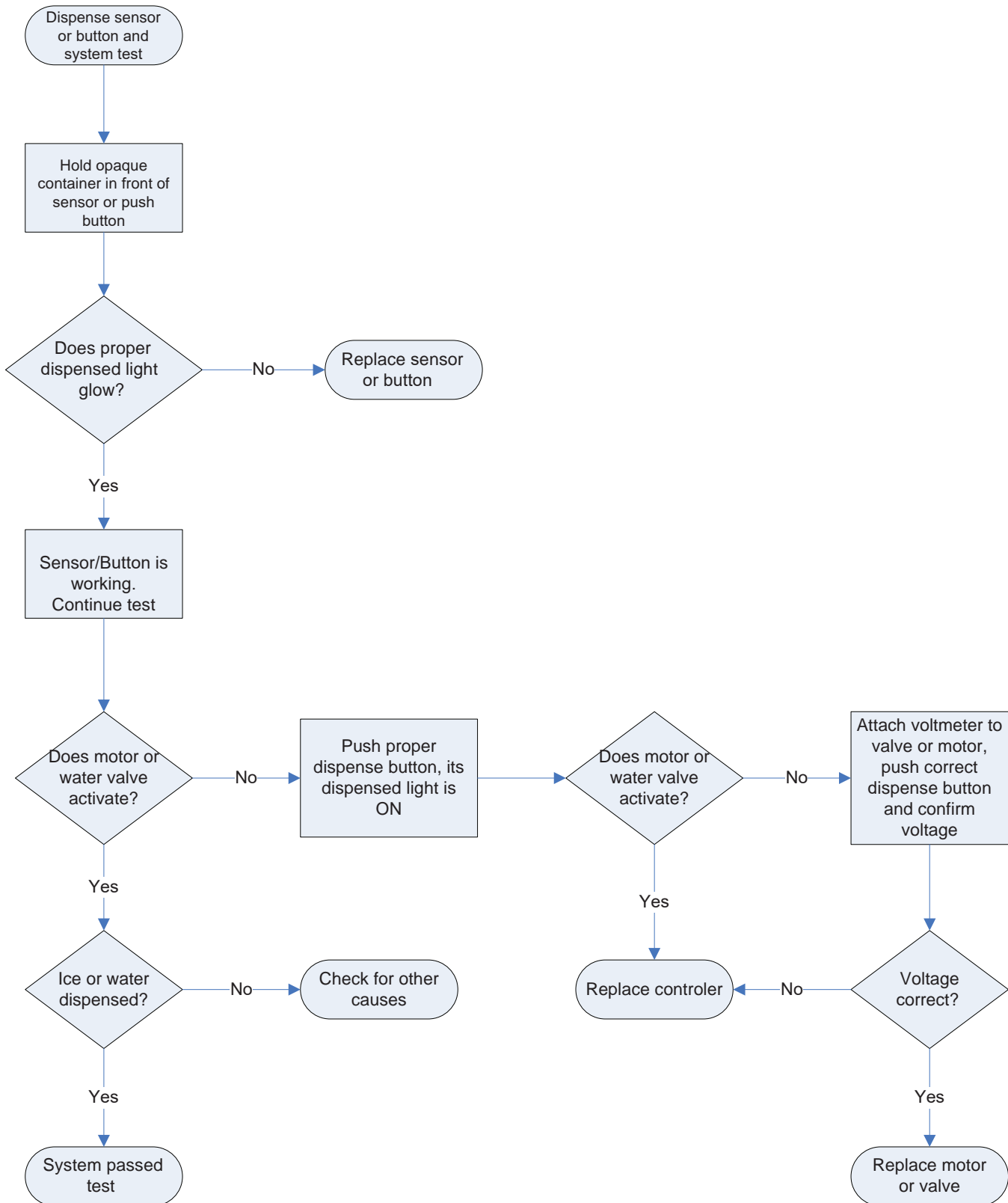

HID312, HID525, HID540

Service Manual

Test Procedures

Photo-Eye Bin Control

Remove front panel.

Check controller code display. If the unit is in ice making mode (status light on) there will normally either be an F or a b displayed.

If the bin is full, b is displayed.

If the bin is not full and the unit is in ice making mode, F is displayed.

if the bin is not full and the unit is off, O is displayed.

False bin full: If the bin is not full and b is displayed:

1. Check for loose connection at the harness to the photo eye sensors.
2. Check for broken wire at sensor.
3. Check for something blocking the sensors, which can include scale buildup.



Rotation Sensor

The sensor consists of a pick up and a magnet. The pick up has a wire that connects to the controller. The magnet is in the rotating magnet holder on top of the auger motor. if the rotor is loose, it will not rotate and the sensor will shut the machine off for no rotation.

1. Remove front and left side panels.
2. Remove motor cover.
3. Check that rotor has magnet and is secure to motor shaft.
4. Check gap from the sensor to magnet. Should be .003"

Note: The use of an impact driver can assist in removing rotor screw. Special thin open end wrench may be needed to hold motor shaft, it fits under the magnet rotor.

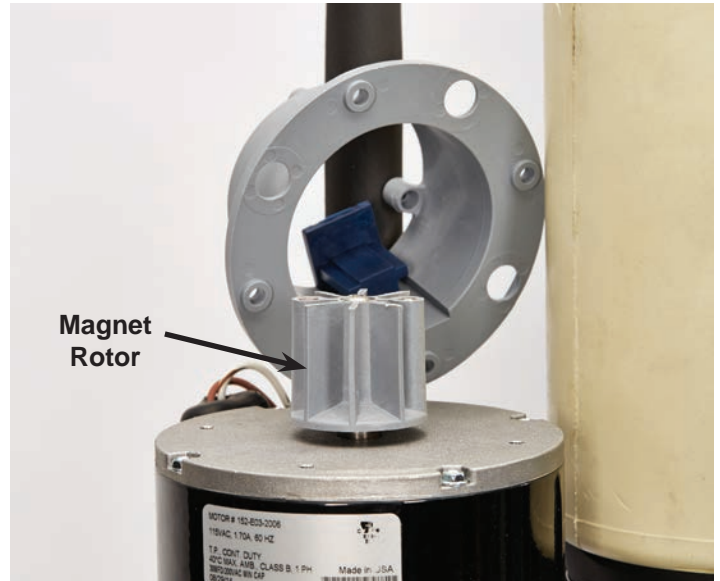

Dispensing Motor

See chart on prior page.

Remove splash panel.

Place voltmeter probes on motor terminals.

Press Dispense Ice and confirm voltage. If voltage is correct and motor does not function, replace dispense motor.

Note: 230 volt motor in an 115 volt machine will rotate with an empty bin but not one with ice. Be SURE to confirm voltage on label to match ice machine voltage.

HID312, HID525, HID540

Service Manual

Test Procedures - Refrigeration

The HID refrigeration system is steady-state. When in operation and stabilized, it will maintain nearly constant discharge and suction pressures.

Items that can affect that are:

- Irregular water flow
- Erratic thermostatic expansion valve
- Changes in room air temperature

Normally use of refrigeration gauges is unnecessary. If the unit is making ice properly, it is highly likely that all is normal. Refrain from attaching gauges, and then only use very short hoses to avoid changing the amount of refrigerant charge. See pressure information on page 9.

The compressor gets its power from the contactor, which is operated by the controller. It must be working or the compressor will be off.

Compressor Starting

The HID312 uses a current relay for starting. The HID525 and HID540 use a potential relay. Both have start capacitors.

HID312 current relay: The contacts of a current relay are normally open and close when the current is high. They stay closed until the compressor starts and the current drops off.

Compressor starts but current too high, overheats. If the relay does not open the start winding will remain powered and there will be current in the wire between the start capacitor and the compressor. Replace the relay.

Compressor does not start. Current relay contacts may be open because relay coil is open, check for continuity. Start capacitor may have failed.

HID525 or HID540 potential relay: The contacts of this relay are normally closed and open when the compressor starts.

Compressor starts but current too high, overheats. If the relay contacts do not open, there will be current from the start capacitor. Replace the relay.

Compressor does not start. Relay contacts open, check for continuity. Replace relay if open. Start capacitor may have failed.

Capacitor Testing

Capacitors may be tested using a multimeter, but begin with a visual test. A good indication of a failed capacitor is one that is bulging or leaking.

If the capacitor looks ok, check it with a multimeter.

1. Discharge the capacitor.
2. Set a digital meter to a high resistance scale of at least 4k.
3. Put the probes on the capacitor terminals and observe the display. It should provide a reading and then show Open Line. If no reading, the capacitor has failed and should be replaced.

If the meter has a Capacitance setting, use it to measure the capacitance, replace if not near to the mfd listed on it.

Compressor Testing

Because the compressor is the hermetic type, the available testing methods are limited. Some items that can be measured are winding resistance and amp draw.

If the compressor does not start and a check with an amp meter shows it does not draw any current, it is likely it has an open winding or overload. Those can be checked using a multimeter.

If the compressor is hot the overload may be open. An open overload is an indication of a worn compressor, defective starting components or high superheat.

Note: Normal operating temperature of the compressor dome is 85 - 95 degrees F. - warm to the touch.

If the overload is open and the compressor is not hot, the overload itself could be the problem. Overloads also open due to high current and a shorted winding could cause that. Check for shorted or grounded windings with a multimeter.

High superheat is caused by lack of refrigeration, possibly from low charge or a TXV starving the evaporator.

HID312, HID525, HID540

Service Manual

Test Procedures Auger and Gear Reducer

Auger

The auger must be clean and undamaged to work properly.

Remove it from the evaporator to confirm.

Note: A wet auger will appear clean - dry it to check for scale.



Damaged auger flight edges are not repairable and the auger must be then be replaced.



Auger Motor

The auger motor is a PSC motor with a capacitor. If the motor will not start, check first for voltage to the motor.

If there is full voltage to the motor, check the capacitor and motor windings, replace the motor if the winding is open. Replace the capacitor if it is damaged, open or weak.

Note: The replacement motor is supplied attached to a gear reducer cover. Remove the motor from the cover and attach it to the gear reducer.

A reversed motor code (1) is a strong symptom of a motor that should be replaced.

Gear Reducer

The gear reducer is a sealed component. No gears or shaft bearings are available. A gear reducer without motor is available.

A properly operating gear reducer will operate quietly and draw a consistent amount of amps. It will not leak lubricant. Oil discharge is a strong indicator of water infiltration and is cause for replacement.

High amp draw could be caused by scale build up in the evaporator. Clean it first, then check amp draw. Confirm the top and lower bearings are not seized or rough.

A motor that rotates but the output shaft does not turn indicates a stripped gear and is cause for the gear reducer section to be replaced.

HID312, HID525, HID540

Service Manual

Dispensing Motor

Removal - must remove the bin

1. Vend or melt out all ice.

Note: Only add 16 oz or 1/2 liter water to the bin at a time, as excess water will drain out the spout.

2. Disconnect electrical power to unit.

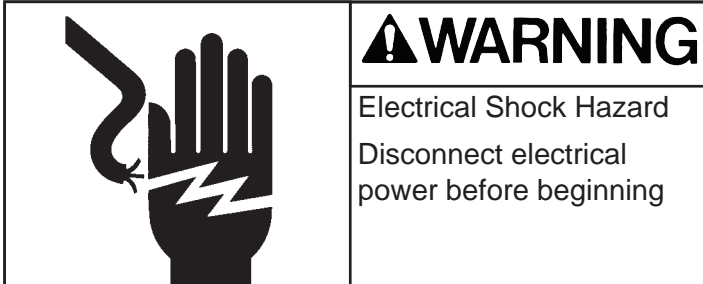

3. Remove front, top, side and upper back panel.
4. Remove splash panel.
5. Disconnect ice level control at harness.
6. Remove ice storage bin cover, set aside.
7. Remove agitator (rotate CCW), set aside.
8. Remove 2 thumbscrews & chute cover, set aside.
9. Lift up and remove dispense rotor, set aside.
10. Remove ice sweep.
11. Remove ice delivery chute and chute cover.
12. Remove dispense motor drive pin.

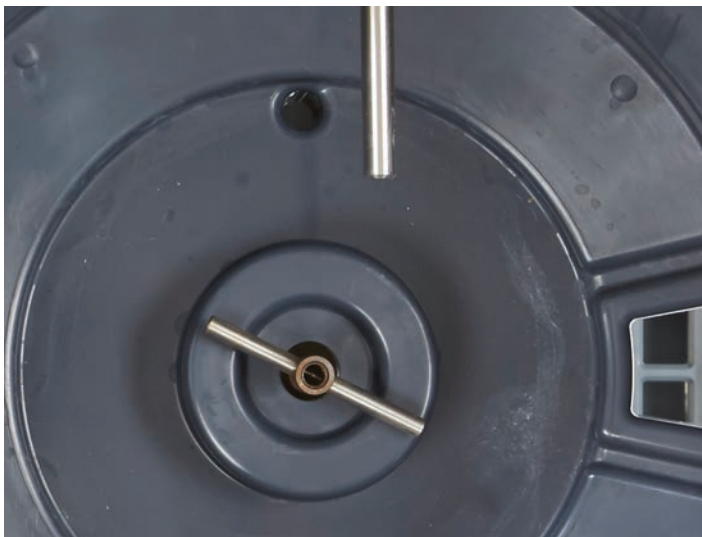

13. Twist and remove the water and ice dispense chutes.
14. Remove the chute mounting panel.

15. Locate two 3 prong knob bolts under the bin. Remove them.

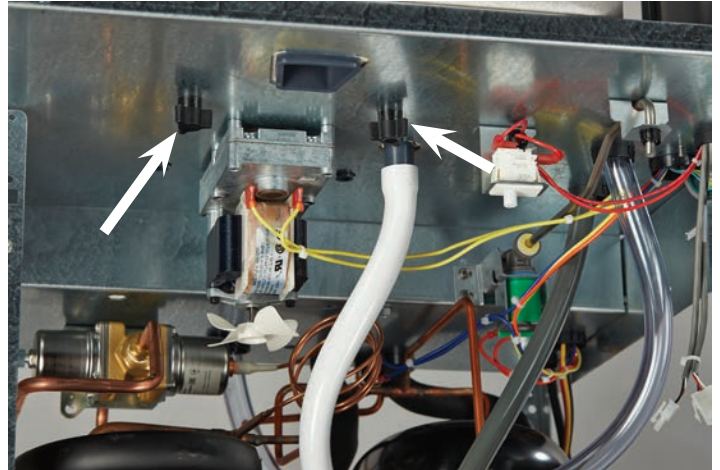

16. Locate bin drain and disconnect it from bin fitting.
17. Lift the bin up and off the chassis.
18. Disconnect wires to dispense motor.
19. Remove 4 bolts holding motor to machine and remove the motor.
20. Install new motor, be sure it is the correct voltage and attach the cooling fan blade.

Dispensing Sensors

1. Disconnect electrical power to unit.
2. Remove splash panel, disconnect sensor from harness.
3. Remove 6 screws holding sensor bracket to splash panel and pull the sensor body out of the holder.
4. Install new sensor.
5. Reconnect harness.



Reference: Ice / water dispense sensors, 01- is ice. has male contact pin, 3 pin on control top. Water is -02. Connects on control bottom.

HID312, HID525, HID540

Service Manual

Photo Eye - Bin Control

1. Remove front panel.
2. Unplug photo eye from harness. b will be displayed on controller.

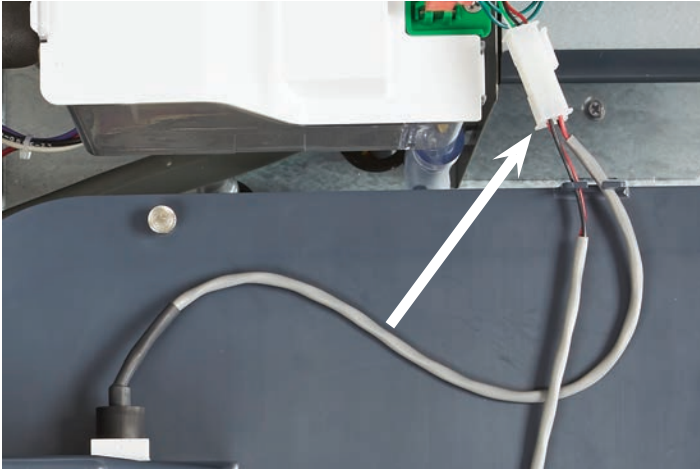

3. Remove 3 thumbscrews holding bin top to bin.
4. Lift top off bin.

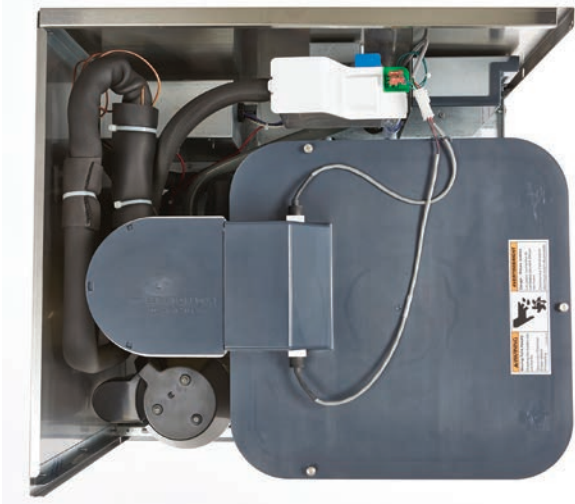

5. Pull clip from each photo eye holder and push holder in to release.

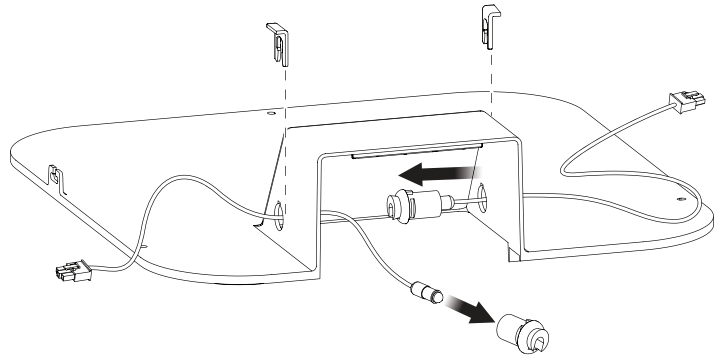

6. Grasp the rubber holder and sensor, pull apart to separate.

Note: Be sure to hold the sensor as close as possible to the holder. Do not pull on the wire.

7. Insert new sensor into holder, it will snap into place when pushed in far enough.
8. Route sensors from inside the bin top, re-secure each with a clip on the outside.
9. Place bin top on bin, secure with the thumbscrews.
10. Reconnect to harness and check that the b goes out.
11. Return front panel to its original position.

HID312, HID525, HID540

Service Manual

Gear Reducer

Removal - bin removal recommended

1. Vend or melt out all ice.

Note: Only add 16 oz or 1/2 liter water to the bin at a time, as excess water will drain out the spout.

2. Disconnect electrical power to unit.

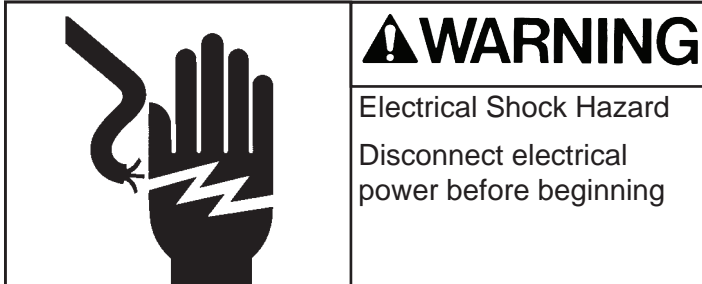

3. Remove front, top, side and upper back panel.
4. Remove splash panel.
5. Disconnect ice level control at harness.
6. Remove ice storage bin cover, set aside.
7. Remove agitator (rotate CCW), set aside.
8. Remove 2 thumbscrews & chute cover, set aside.
9. Lift up and remove dispense rotor, set aside.
10. Remove ice sweep.
11. Remove ice delivery chute and chute cover.
12. Remove dispense motor drive pin.
13. Twist and remove the water and ice dispense chutes.
14. Remove the chute mounting panel.
15. Locate two 3 prong knob bolts under the bin. Remove them.
16. Locate bin drain and disconnect it from bin fitting.
17. Lift the bin up and off the chassis.



18. Disconnect wires to auger motor.
19. Remove 3 screws holding motor cover to motor.
20. Remove 4 screws holding rotation sensor holder to motor.



21. Use a cordless impact driver to remove the screw holding the magnet rotor. If needed use the special thin wrench to hold motor shaft.
22. Remove four 1/2" hex head bolts securing

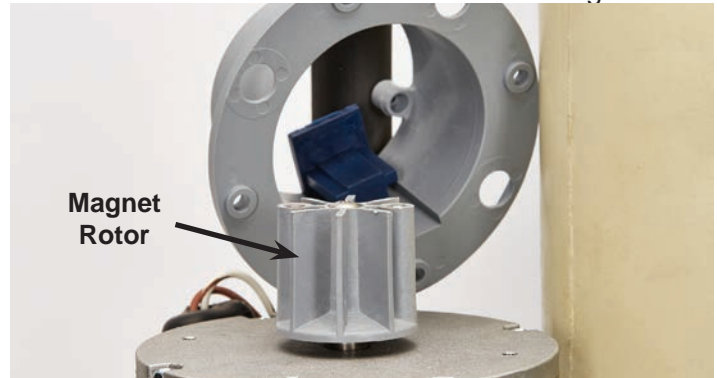

- evaporator assembly to gear reducer cover.
 23. Remove four 1/2" hex head bolts securing gear reducer condensate pan to chassis.
 24. Separate gear reducer from evaporator and lift it from the machine.
 25. Remove three 1/4 hex socket head screws securing pan to gear reducer.
- Install new gear reducer. Be sure vent plug is open

HID312, HID525, HID540

Service Manual

Auger

It is the manufacturer's recommendation that the top bearing, bottom bearing and water seal be replaced at the same time.

Extruder / Breaker

1. Remove top panel
2. Remove storage bin cover.
3. Slide chute cover back and remove.
4. Unscrew ice sweep.
5. Lift up and pull ice chute off evaporator.
6. Remove four 1/4 inch hex head socket screws.



Auger Motor

The auger motor may be replaced without removing the gear reducer. Due to manufacturing and testing reasons, the replacement auger drive motor is supplied mounted on a gear reducer cover. It is not necessary to replace the gear reducer cover.

7. Lift breaker off auger.

Auger

1. Shut water off to machine.
2. Disconnect electrical power.
3. Remove splash panel.
4. Drain reservoir
5. Remove top panel
6. Remove storage bin cover.
7. Slide chute cover back and remove.
8. Unscrew ice sweep.
9. Lift up and pull ice chute off evaporator.
10. Remove four 1/4 inch hex socket head socket screws.
11. Return ice sweep to auger.
12. Lift on ice sweep to remove auger.

1. Remove 3 screws holding motor cover to motor.
2. Remove 4 screws holding rotation sensor to motor.
3. Use a cordless impact driver to remove the screw holding the magnet rotor. If needed use the special thin 3/8 open end wrench to hold the motor shaft.
4. Remove the original drive motor.
5. Separate the replacement drive motor from the shipping casting.
6. Install the rotor of the replacement motor into the gear reducer.
7. Attach the winding of the replacement motor to the gear reducer.
8. Attach the magnet rotor to the new motor shaft.
9. Attach the sensor and its holder to the motor.
10. Attach the motor cover to the motor. Reconnect wires.

HID312, HID525, HID540

Service Manual

Evaporator

1. Go thru all steps to remove the auger.
2. Go thru all steps to remove the bin.
3. Recover the refrigerant charge.

7. Lift the evaporator up and off the bottom bearing retainer. The stationary half of the water seal will be in the bottom of the tube. The rotating half is on the auger.

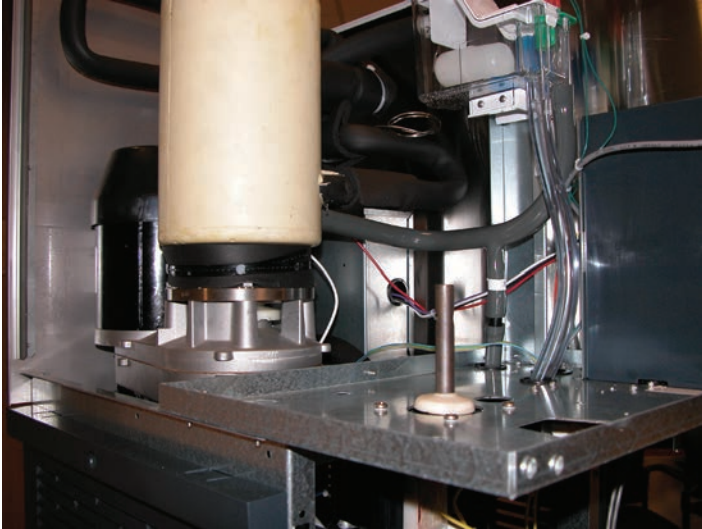

4. Remove foam wrap from bottom of evaporator.
5. Remove the four 1/4 inch hex socket head screws at the bottom of the evaporator.

8. Confirm auger is un-damaged.
9. Install new water seal.
10. Replace bottom and top bearings.
11. Attach new evaporator to adapter.
12. Replace the dryer and evacuate the system to at least 300 microns.
13. Weigh in the nameplate charge.

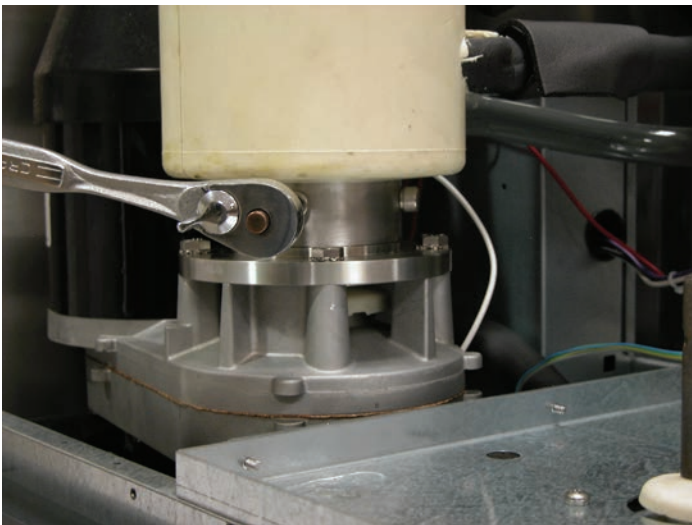

6. Un-braze the evaporator refrigerant inlet and outlet.

HID312, HID525, HID540

Service Manual

Water Seal and Auger Bearings

Water Seal

1. Go thru all steps to remove the auger.
2. Remove the 4 allen head screws at the bottom of the evaporator.
3. Lift the evaporator up and off the bottom bearing retainer.
4. Push the water seal up on one side until it twists, grab it and pull it out.
5. Remove the rotating half from the bottom of the auger.
6. Clean the auger shoulder and add a very thin bead of food grade sealant to the bottom of the auger.

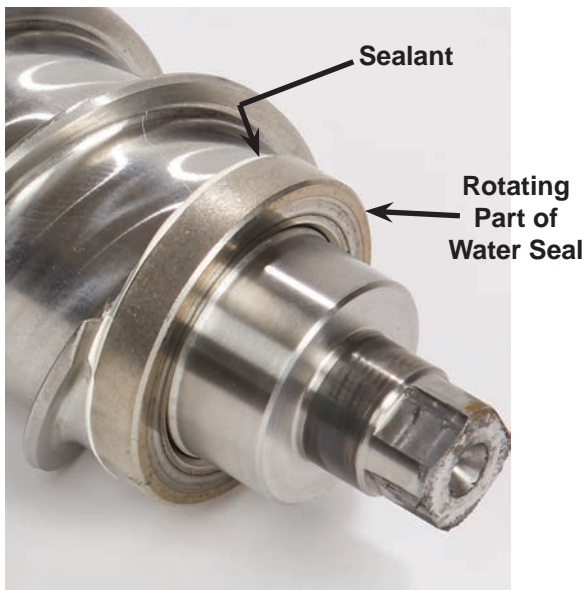

7. Carefully push the new rotating half of the water seal up against the sealant as far as possible. It should seat tightly and straightly against the auger shoulder. Do not put fingerprints on the sealing surface.
8. Wet the outside edge of the stationary half of the water seal and insert it into the bottom of the evaporator.
9. Slip the evaporator onto the bottom bearing retainer, the bearing retainer will push the water seal up into the correct position.

Note: The bottom bearing should have been replaced at this time.

10. Secure the evaporator to the bearing retainer with the original socket head screws. Be sure they are tight.

Top Bearing:

1. Go thru the process of removing the extruder breaker.
2. Remove the clip holding the bearing.
3. Tap out the old bearing.
4. Use the old bearing as something to tap on and drive the new bearing into the extruder.
5. Reinstall the clip.

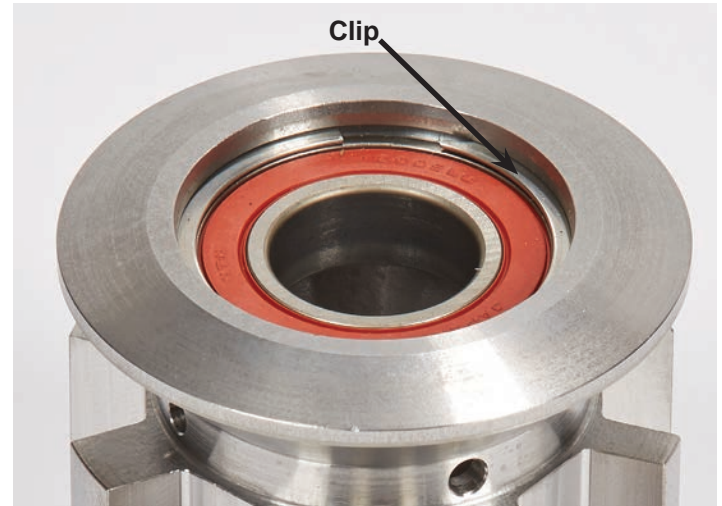

Bottom Bearing:

1. Go thru the process of removing the auger.
2. Remove the 4 allen head screws at the bottom of the evaporator.
3. Remove the bolts holding the bearing retainer to the gear reducer.
4. Separate the gear reducer, evaporator and bearing retainer.
5. Remove the clip.
6. Tap out the old bearing.
7. Use the old bearing as something to tap on and drive the new bearing into the extruder.



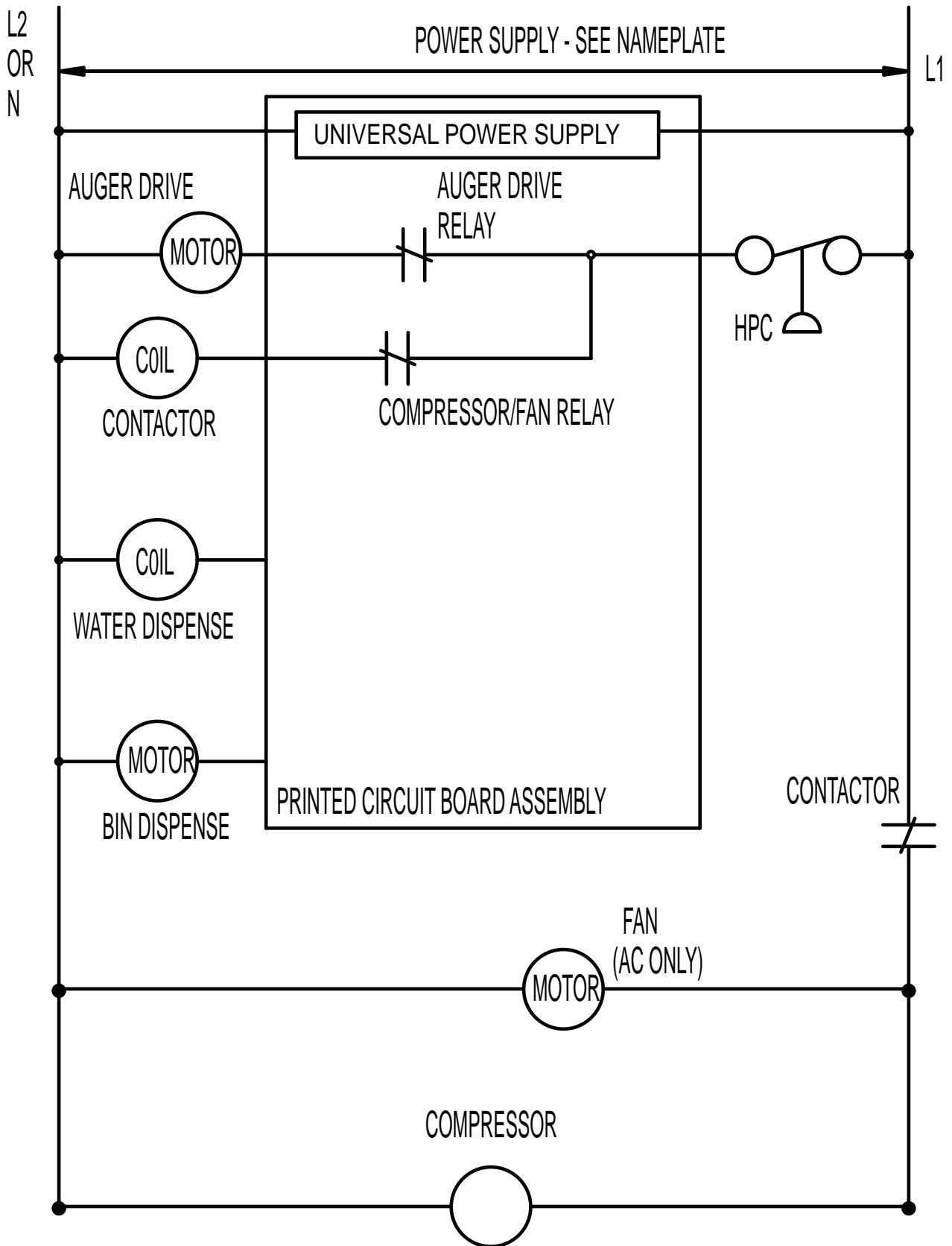

HID312, HID525, HID540

Service Manual

HID525 or 540 Wiring Diagram

17-3489-01

1 WIRE COLOR FOR 208-230/60/1 AND 115/60/1 UNITS: BLACK
 WIRE COLOR FOR 208-230/50/1 UNITS: BROWN

2 WIRE COLOR FOR 115/60/1 UNITS: WHITE
 WIRE COLOR FOR 208-230/50/1 UNITS: BROWN

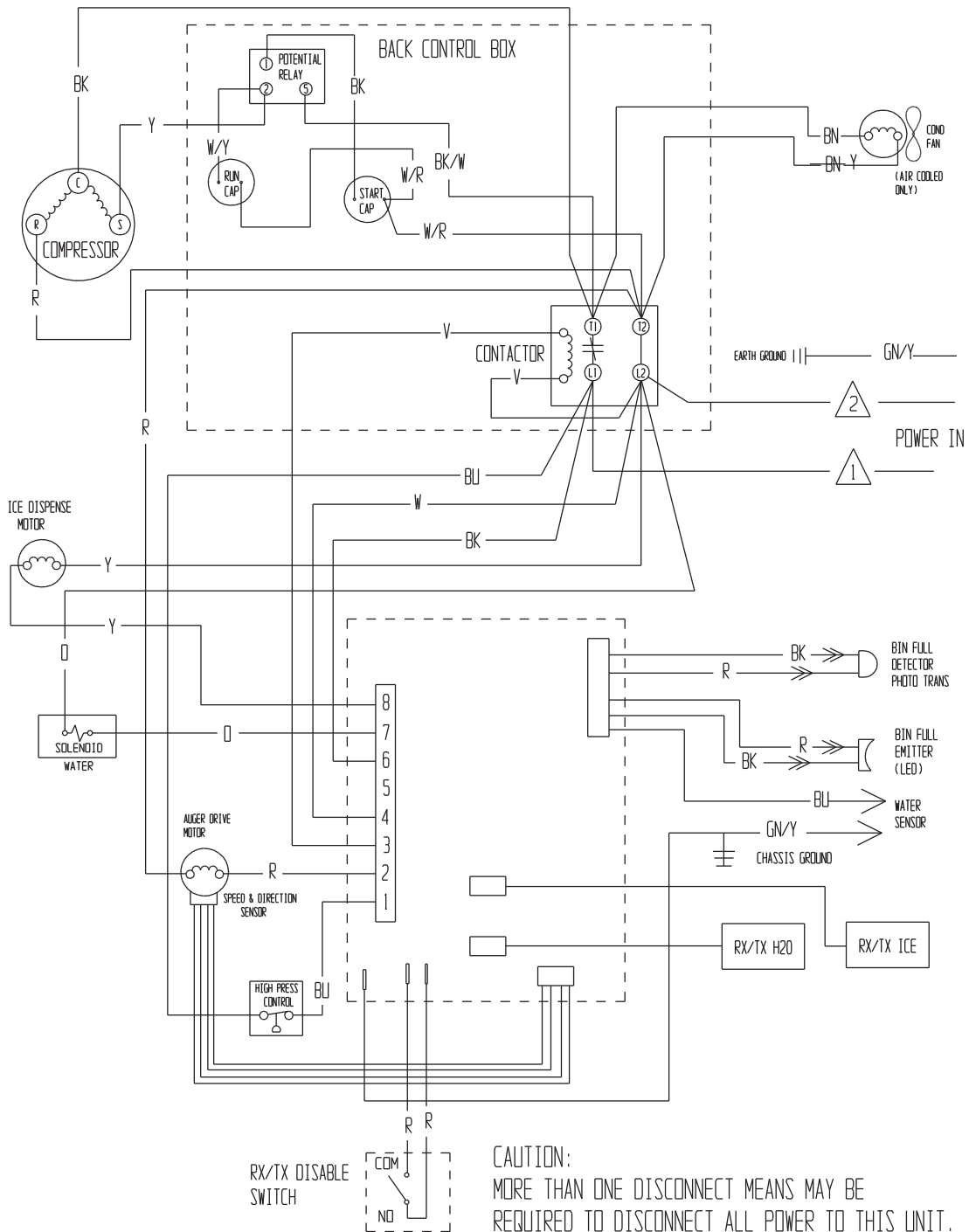

CAUTION:
 MORE THAN ONE DISCONNECT MEANS MAY BE
 REQUIRED TO DISCONNECT ALL POWER TO THIS UNIT.

ALL CONTROLS SHOWN IN ICE MAKING MODE
 WITH ALL DISPENSING SYSTEMS IN OPERATION

SCOTSMAN ICE SYSTEMS

775 Corporate Woods Parkway

Vernon Hills, IL 60061

USA

847-215-4500

800-726-8762

www.scotsman-ice.com