



S E R V E R

SERVE BETTER™

Remote Dispensing System

Remote Pump with 36" Hose
SINGLE POUCH SYSTEM
85783

Remote Pump with 36" Hose
TWIN POUCH SYSTEM
85784

Use with pouches up to 3 gallons
with either 16mm fitment
or 38mm connector.

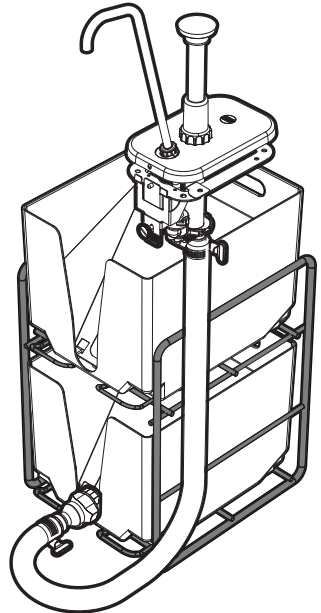
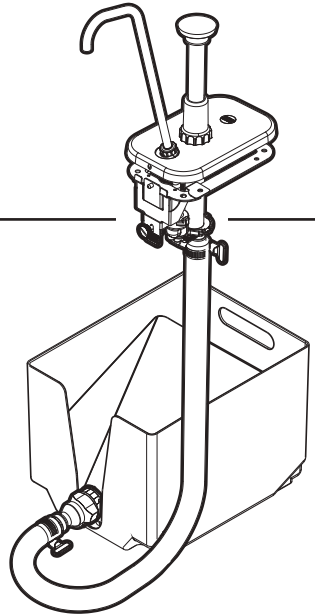
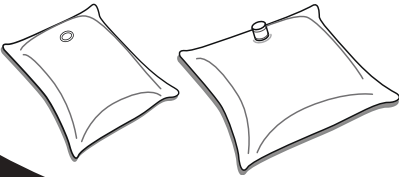

Thank You

...for purchasing our Remote Dispensing System.
This manually operated system simplifies
high-volume dispensing, eliminating the
hassle of a CO₂ driven dispenser.

HIGH VOLUME—HIGHLY CONVENIENT

REMOTE SYSTEM PARTS

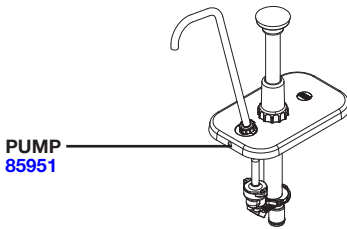

PUMP
85951

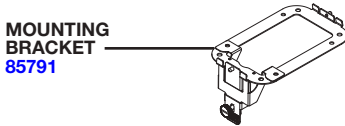

MOUNTING BRACKET
85791

HOSE ASSEMBLY
85758

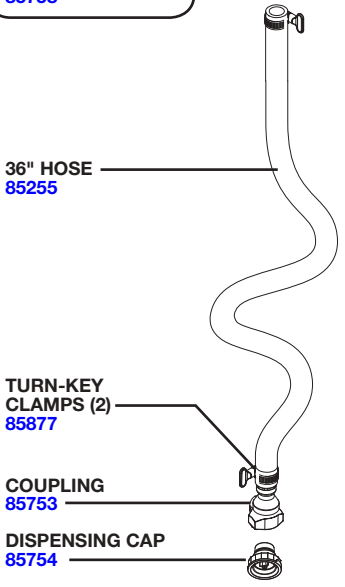

36" HOSE
85255

TURN-KEY CLAMPS (2)
85877

COUPLING
85753

DISPENSING CAP
85754



16MM ADAPTER
85264

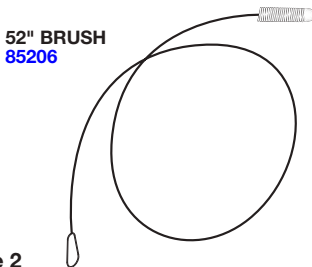

52" BRUSH
85206

SINGLE POUCH SYSTEM 85783

EVACUATION PLATE
07814

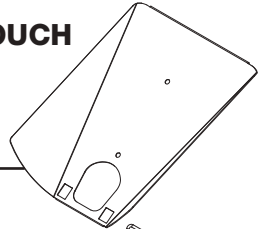

TORSION SPRING
07813

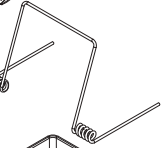

POUCH SUPPORT
07811

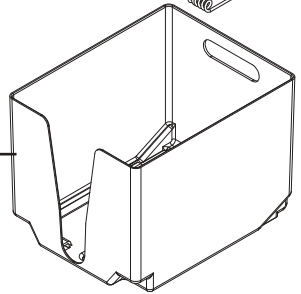

TWIN POUCH SYSTEM 85784

(2) EVACUATION PLATES
07814

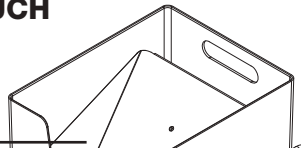

(2) TORSION SPRINGS
07813

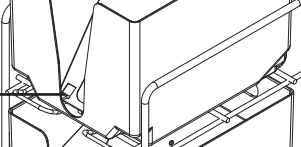

(2) POUCH SUPPORTS
07811

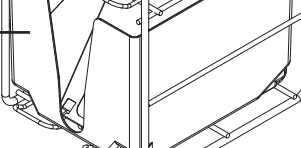

WIREWISE RACK
88643



Twin system includes

(2) DISPENSING CAPS
85754



&

(2) 16MM ADAPTERS
85264



MOUNTING BRACKET DETAILS

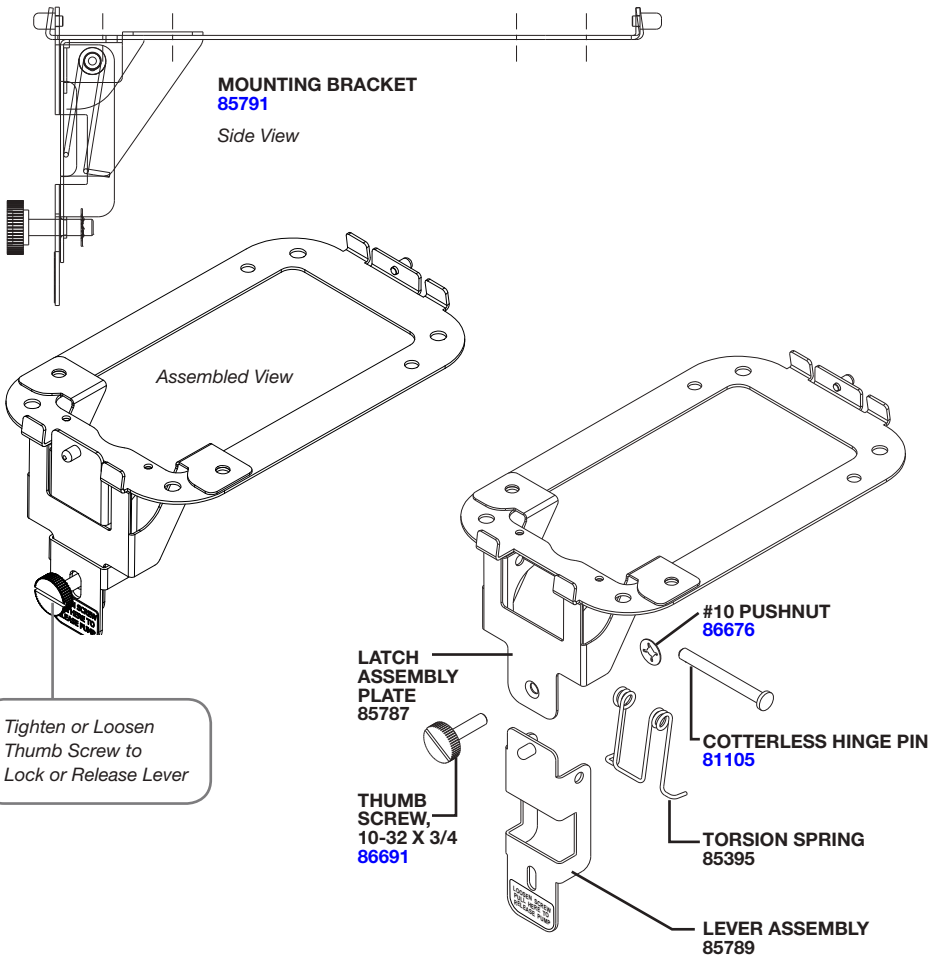

SAFETY



According to food and safety regulations, most foods must be stored and/or served at certain temperatures or they could become hazardous. Check with local food and safety regulators for specific guidelines.

Be aware of the product you are serving and the temperature the product is required to maintain. Server Products, Inc. cannot be responsible for the serving of potentially hazardous product.

IMPORTANT

Clean, rinse, sanitize, and dry parts daily or regularly to comply with local sanitization requirements.



NSF International lists this pump as: "Not acceptable for dispensing potentially hazardous foods."

QUICK START

YOU WILL NEED:

- A qualified person to install the countertop bracket
- Screwdriver, (4) screws, router and/or saw equipment

1 INSTALL THE COUNTERTOP BRACKET

- Choose a location with easy access and convenient height for pump.
- Allow room for slack in hose during set-up, pouch replacement and take-down.

IMPORTANT TIP:

Do not locate countertop hole directly above pouch support(s).

Offset the hole to leave space for pump and hose below.

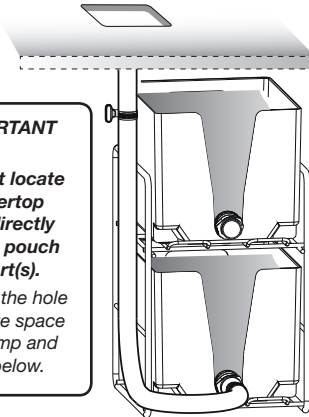

- Use **cutout template** included to mark, cut and drill holes.
- Secure the bracket with four screws.

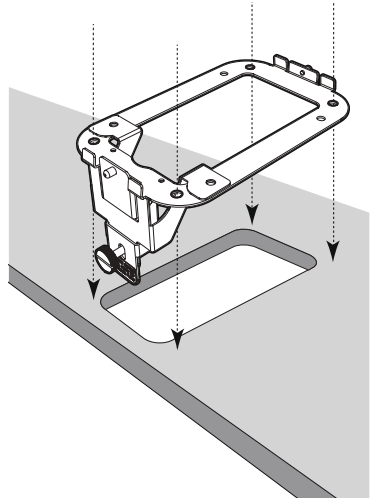

2 INSERT THE PUMP INTO BRACKET

Always clean pump first. Refer to separate instructions for the pump.

- Insert pin on rear of bracket into hole on rear of lid.
- Pull the under-counter lever forward to allow front pin of bracket into front hole of lid.
- Release lever to secure front bracket pin.
- Tighten thumbscrew to lock lever.

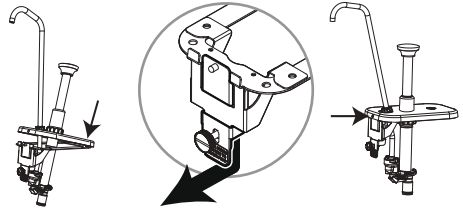

3 ATTACH HOSE TO PUMP

- Slide hose onto valve connector at bottom end of pump.
- Rotate hose clamp turn-key clockwise to secure hose.

TIP: *Hose may be trimmed if length is excessive.*

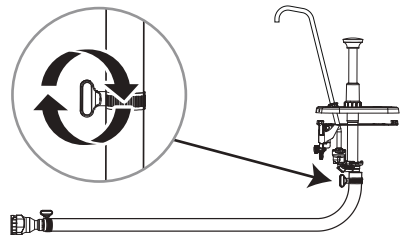

4 PREPARE POUCH(ES)

Place condiment pouch on flat surface with pouch connector or fitment facing upward.

If pouch has

38MM EXTERNAL CONNECTOR

- Remove pouch cap.
- Screw dispensing cap onto connector.

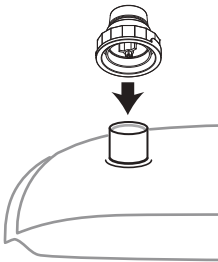

If pouch has

16MM INTERNAL FITMENT

- Screw dispensing cap onto adapter.
- Position adapter directly over center of pouch fitment.
- Press adapter down to pierce through film in pouch fitment.

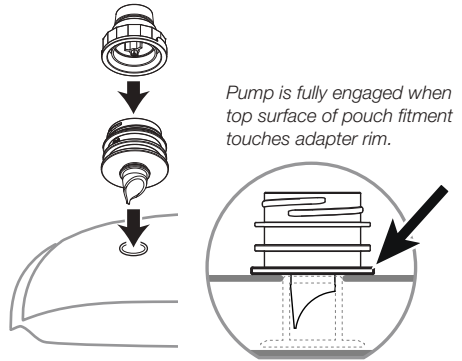

5 PLACE POUCH(ES) INTO POUCH SUPPORT(S)

Locate dispensing cap in front slot directed downward for best evacuation of condiment.

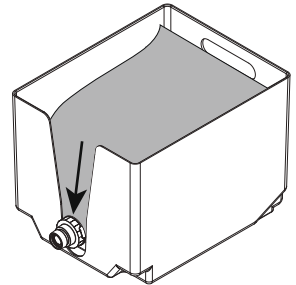

6 PLACE SUPPORT(S) BENEATH COUNTER

Twin pouch system includes wire rack for pouch supports.

7 CONNECT HOSE TO POUCH

Snap hose end onto dispensing cap.

8 PRIME PUMP

Repeatedly press pump knob until condiment is drawn up from pouch and hose below.

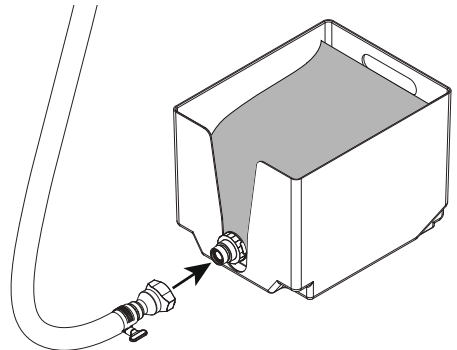

SWITCHING POUCHES

WHEN A CONDIMENT POUCH BECOMES EMPTY...

1 DISCONNECT HOSE FROM EMPTY POUCH

Press button on side of hose coupling to release.

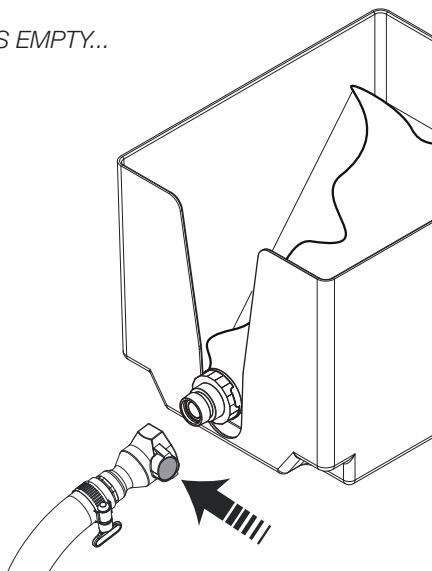

2 SNAP HOSE COUPLING ONTO DISPENSING CAP ON NEW POUCH

See page 5 for how to prepare pouch(es).

DID YOU KNOW?

The hose coupler and dispensing cap prevent leaks when hose is disconnected.

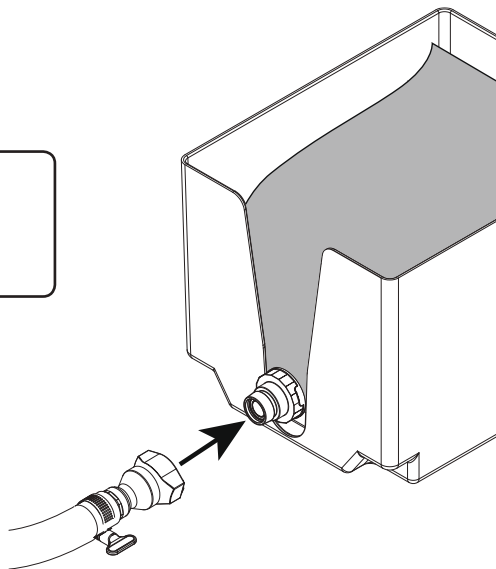

DISASSEMBLY

1 DISCONNECT HOSE FROM PUMP

Turn hose clamp turn-key counter-clockwise to loosen the hose.

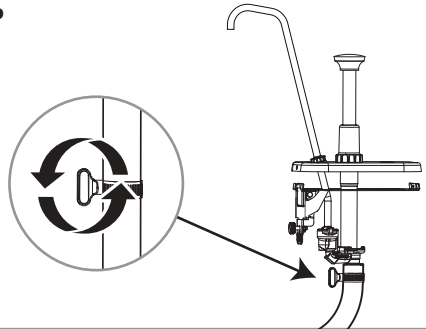

2 DISCONNECT HOSE FROM POUCH

Press button on side of hose coupling to release.

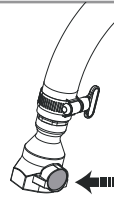

3 REMOVE PARTS(S) FROM POUCH

Unscrew dispensing cap from pouch.

IF USED: Remove adapter from 16mm pouch fitment.

IMPORTANT: Only throw away empty pouch.
Keep any dispensing cap and adapter fitment.

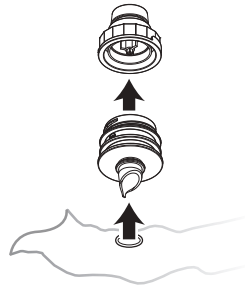

4 REMOVE PUMP FROM COUNTER BRACKET

- Loosen thumbscrew on bracket.
- Pull lever under counter to release front hole of lid from front pin of bracket.
- Lift pump free from pin in back of bracket.

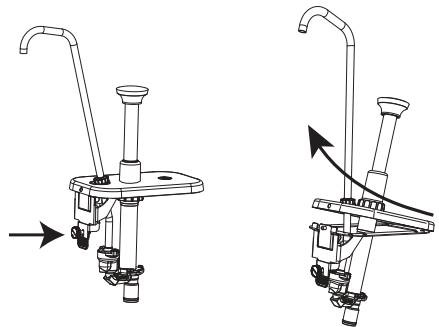

CLEANING

Refer to separate instruction manual for pump cleaning.

1 CLEAN

After disassembling, thoroughly clean all washable parts with soap and hot water.

2 RINSE

 fully with clear water.

3 SANITIZE

all parts according to local sanitization requirements. All parts in contact with food must be sanitized.

4 AIR DRY

 all parts fully.

YES!

Use dishwashing soap and hot water.



Use supplied brush to clean inside hose.

- External surfaces may be wiped clean with a clean damp cloth.
- Glass and surface cleaners approved for use in food contact areas may be used.
- Do not use abrasive, caustic or ammonia based cleansers.
- Do not use metal scrapers or cleaning pads that could scratch surfaces.

SERVER PRODUCTS LIMITED WARRANTY

2
YEAR
WARRANTY



Server Products equipment is backed by a two-year limited warranty against defects in materials and workmanship.

For complete warranty information go to:

www.Server-Products.com

GENERAL SERVICE, REPAIR OR RETURNS

Before sending any item to Server Products for service, repair, or return, contact Server Products customer service to request a **Return Authorization Number**. Merchandise must be sent to Server Products with this number. Service is extremely prompt. Typically, units are repaired and ship out within 48 hours.

Merchandise being returned for credit must be in new and unused condition and not more than 90 days old and will be subject to a 20% restocking charge.

NEED HELP?

Server Products Inc.

3601 Pleasant Hill Road
Richfield, WI 53076 USA



262.628.5600 | 800.558.8722



SPSALES@SERVER-PRODUCTS.COM

Please be prepared with your **Part Numbers**, as shown on pages 2 & 3.

CUTOUT TEMPLATE

Full Scale 1:1

