



SERVER

SERVE BETTER™

Dry Product Dispenser

MODEL: DPD

1 LITER, SINGLE **86670**

1 LITER, SINGLE **87214**

2 LITER, SINGLE **86680**

2 LITER, SINGLE **87215**

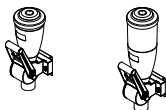

1 LITER, DOUBLE **86690**

2 LITER, DOUBLE **86640**

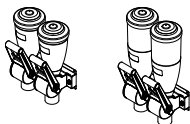

1 LITER, TRIPLE **86650**

2 LITER, TRIPLE **86660**

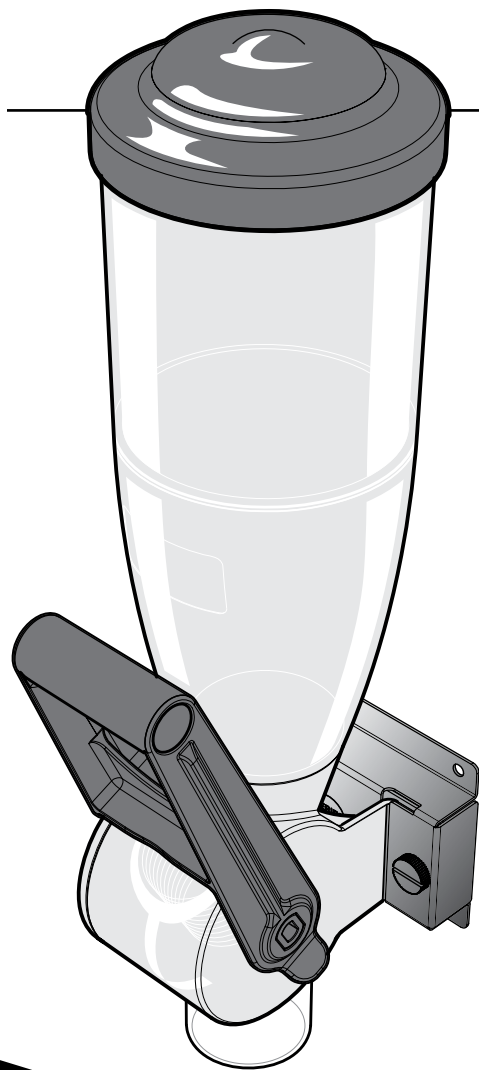
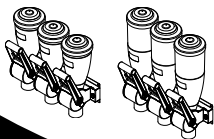

Thank You

...for purchasing our Dry Product Dispenser to showcase your dry toppings and ingredients. Accurately dispense 1/4 oz to 2 oz portions, adjustable in 1/8 oz increments.

SERVE ACCURATE, ADJUSTABLE PORTIONS

PARTS

86688
LID

86681
BODY, 1 LITER

86682
BODY, 2 LITER

86684
PORTION PLUG

86683
CYLINDER

86619
HANDLE

86689
DISCHARGE FITTING TUBE

BRACKETS

Bracket size corresponds to quantity of dispensers in unit.*

87216
SINGLE BRACKET

*Units 87214 & 87215 do not include brackets.

87217
DOUBLE BRACKET

87218
TRIPLE BRACKET

THUMB SCREW(S)

BRACKETS

YOU WILL NEED:

- Screwdriver
- Appropriate fasteners for your surface



INSTALL WALL BRACKET

Select wall location or sturdy vertical surface for mounting.

Consider best location for ease of access to unit and clearance of all movable parts.

Determine proper mounting hardware you will need to supply.

Secure bracket to wall stud(s), anchor bolts in wall, or sturdy vertical surface.

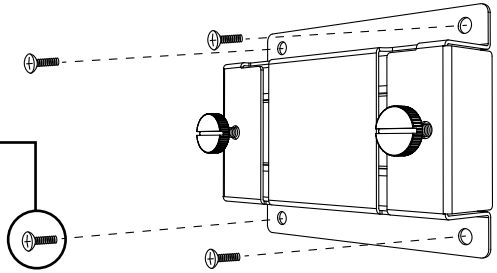

SINGLE BRACKET

You need to supply 4 fasteners.

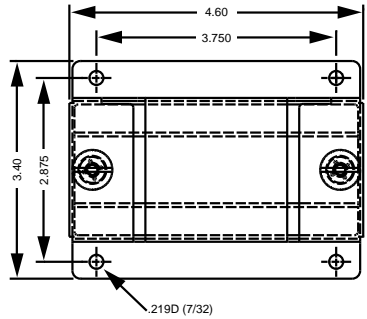
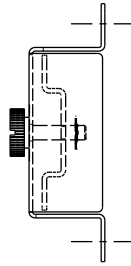

DOUBLE BRACKET

You need to supply 6 fasteners.

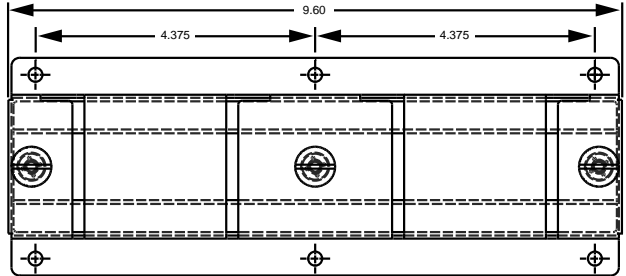

TRIPLE BRACKET

You need to supply 8 fasteners.

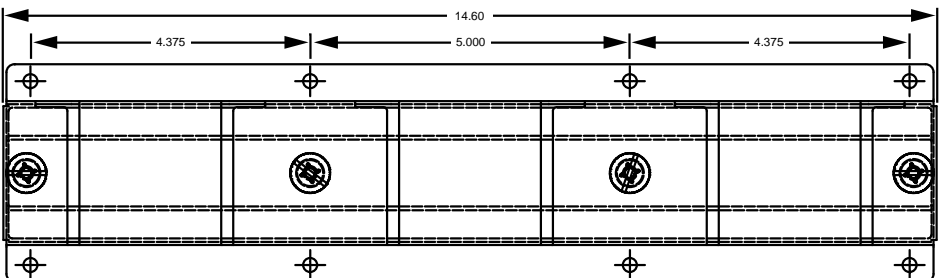

SAFETY



According to food and safety regulations, most foods must be stored and/or served at certain temperatures or they could become hazardous. Check with local food and safety regulators for specific guidelines.

Be aware of the product you are serving and the temperature the product is required to maintain. Server Products, Inc. cannot be responsible for the serving of potentially hazardous product.



NSF International listed.

IMPORTANT

Clean, rinse, sanitize, and dry parts daily or regularly to comply with local sanitization requirements.

CAUTION

Keep fingers clear of all moving parts to prevent operator injury when dispensing product, during cleaning, assembly and disassembly.

CLEANING

1 CLEAN

After disassembling, clean all washable parts with soap and hot water.

2 RINSE

fully with clear water.

3 SANITIZE

all parts according to local sanitization requirements. All parts in contact with food must be sanitized.

4 AIR DRY

all parts fully.



YES!

Use dishwashing soap and hot water.

LID: HAND WASH ONLY

The rest of the dispenser components are dishwasher safe.

- External surfaces may be wiped clean with a clean damp cloth.
- Glass and surface cleaners approved for use in food contact areas may be used.
- Do not use abrasive, caustic or ammonia based cleansers.
- Do not use metal scrapers or cleaning pads that could scratch surfaces.

DISASSEMBLY

1 LOOSEN BRACKET THUMB SCREWS & REMOVE UNIT FROM BRACKET

2 REMOVE LID

3 EMPTY INGREDIENTS FROM UNIT

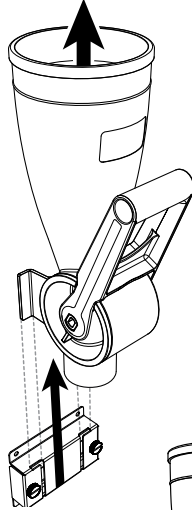
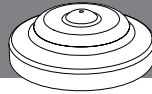

4 REMOVE HANDLE

Use the pull-tab on right side to assist.

5 REMOVE DISCHARGE FITTING TUBE

from bottom opening of dispenser.

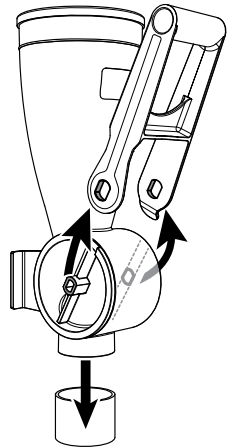

6 REMOVE CYLINDER

from side of unit body.

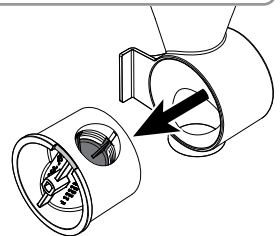

7 REMOVE PORTION PLUG

from cylinder.

Push portion plug out the end of cylinder marked "ML" and "OZ".

If your fingers cannot reach through the end of the cylinder, use a blunt, food-safe kitchen utensil to expel plug.

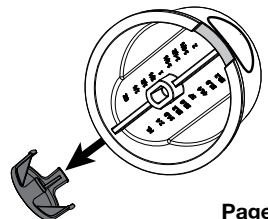

QUICK START



PRACTICE SAFETY. WASH ALL PARTS PROPERLY BEFORE USE. See page 4.

1 SET PORTION CONTROL

Hold cylinder with "ML" and "OZ" markings right-side up.

Insert portion plug, round-side up, into bottom opening of cylinder.

Push plug up to snap into ribs on interior of cylinder.

Ribs indicate portion sizes, marked in 1/8 oz (3.7 mL) increments.

Align bottom tabs on plug with rib indicating desired portion size.

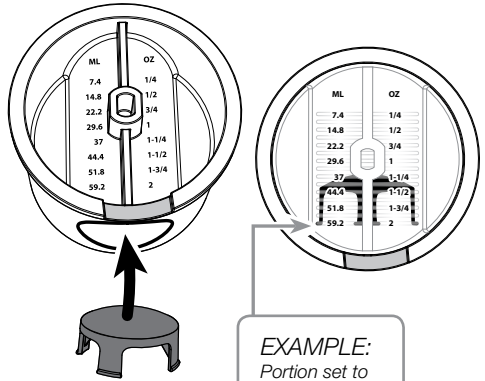

EXAMPLE:
Portion set to
2 oz (59.2 mL).

2 INSERT CYLINDER INTO BODY

Rotate cylinder so that portion markings are upside down.

Turn notch on left side of cylinder rim towards one o'clock position.

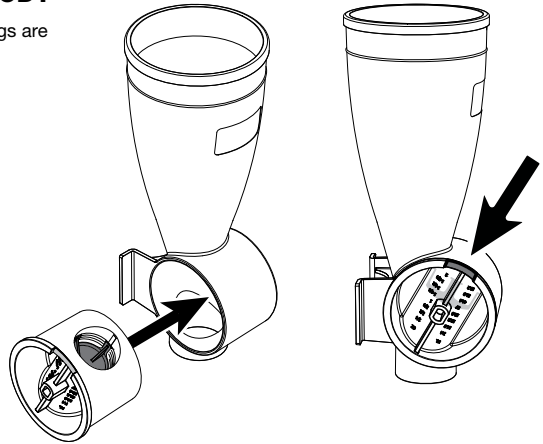
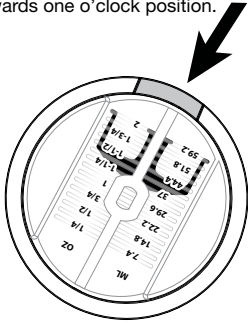

3 INSTALL HANDLE

onto cylinder.

Handle pull-tab must be on right side.

Handle must be in upward position.

Slide handle over both sides of body and cylinder.

Snap handle holes over tabs on each side of cylinder.

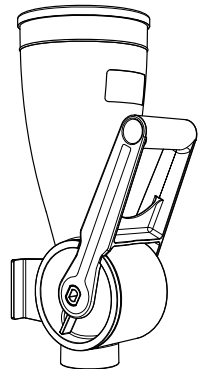
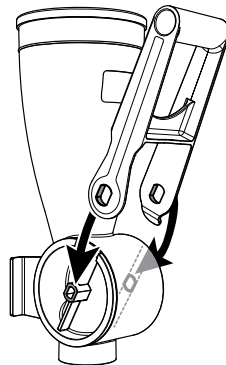
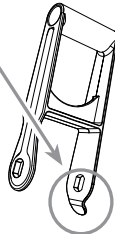

4 ADD DISCHARGE FITTING TUBE

to bottom opening of dispenser.

TIP:

Soft, silicone fitting is easy removed for cleaning if tube contacts food product.

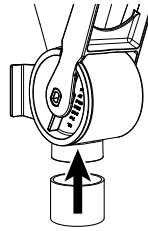

5 INSTALL UNIT INTO BRACKET

See page 3 for bracket installation.

Slide unit flanges into top of wall bracket slots.

Tighten thumb screws on both sides of unit to secure.

IMPORTANT:

Thumb screws may loosen over time due to use.

An unsecured unit puts excess pressure on flanges.

**Prevent flange breakage.
Tighten thumb screws regularly.**

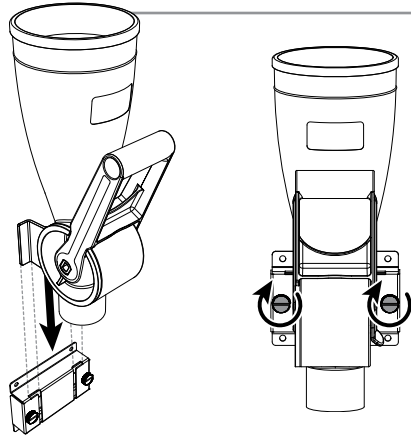

6 ADD DRY INGREDIENTS

to body of unit.

7 PLACE LID ON TOP

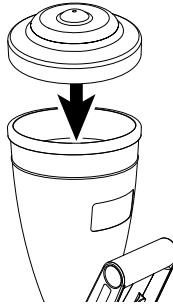

8 SWING HANDLE DOWNWARD

to load the portion.

SWING HANDLE UPWARD

to dispense the portion.

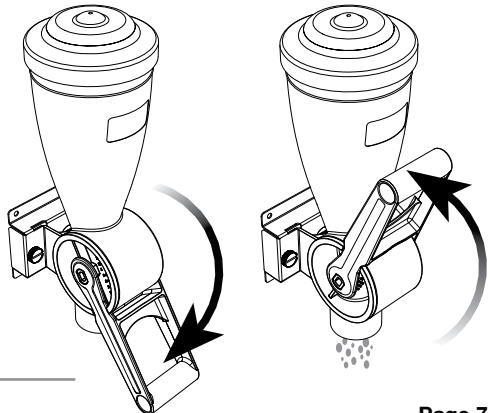

TROUBLESHOOTING

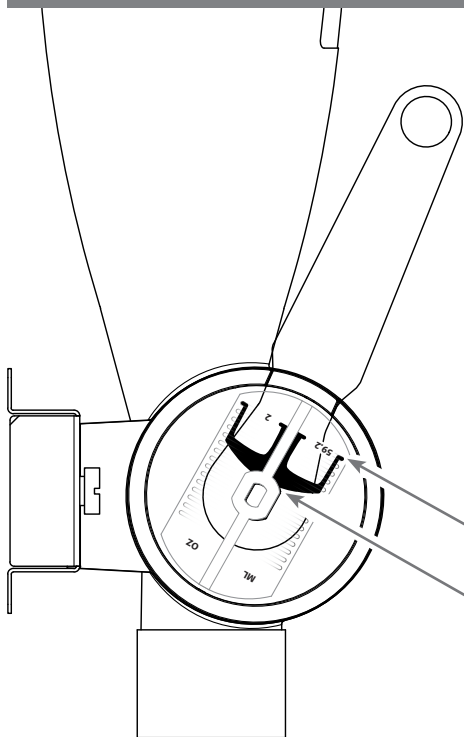

UNIT DISPENSES LITTLE OR NO PRODUCT?

Make sure there is **enough product remaining** to dispense and that the product is **free to move** to the bottom.

Make sure you are dispensing the **right kind of product**. The dry food dispenser is designed for free-flowing foods like candies, toppings and mix-ins. Dissimilar products and those that tend to melt or stick together are not recommended.

FREE FLOW ACCESSORY (1L 86663, 2L 86625) is helpful if bridging of very fine powders occurs.

STIR PADDLE ACCESSORY (1L 86587, 2L 86596) addresses irregular pieces such as cookie crumbs.

Contact our customer service team for assistance: **800.558.8722** or spsales@server-products.com

Make sure the **portion plug is properly installed**. Bottom tabs of portion plug line up with rib indicating portion size.

Round side of portion plug faces away from handle.

DIFFICULT TO REMOVE PORTION PLUG FROM CYLINDER?

Use a blunt, food-safe kitchen utensil to push plug out.

SERVER PRODUCTS LIMITED WARRANTY

2 YEAR WARRANTY



Server Products equipment is backed by a two-year limited warranty against defects in materials and workmanship.

For complete warranty information go to:

www.Server-Products.com

GENERAL SERVICE, REPAIR OR RETURNS

Before sending any item to Server Products for service, repair, or return, contact Server Products customer service to request a **Return Authorization Number**. Merchandise must be sent to Server Products with this number. Service is extremely prompt. Typically, units are repaired and ship out within 48 hours of receipt.

Merchandise being returned for credit must be in new and unused condition and not more than 90 days old and will be subject to a 20% restocking charge.

HELP or ORDERING REPLACEMENT PARTS

Server Products Inc.

3601 Pleasant Hill Road
Richfield, WI 53076 USA



262.628.5600 | 800.558.8722



SPSALES@SERVER-PRODUCTS.COM

Please be prepared with **Part Numbers** for your items. Many of the components have this information stamped on them.

Individual **Part Numbers** are also listed on page 2.