

SERVER

• E S S E N T I A L S •

Extreme™ Countertop Dispenser

MODEL: ECD

07500

Used with pouches up to
3 gallons with 38mm
threaded connector.

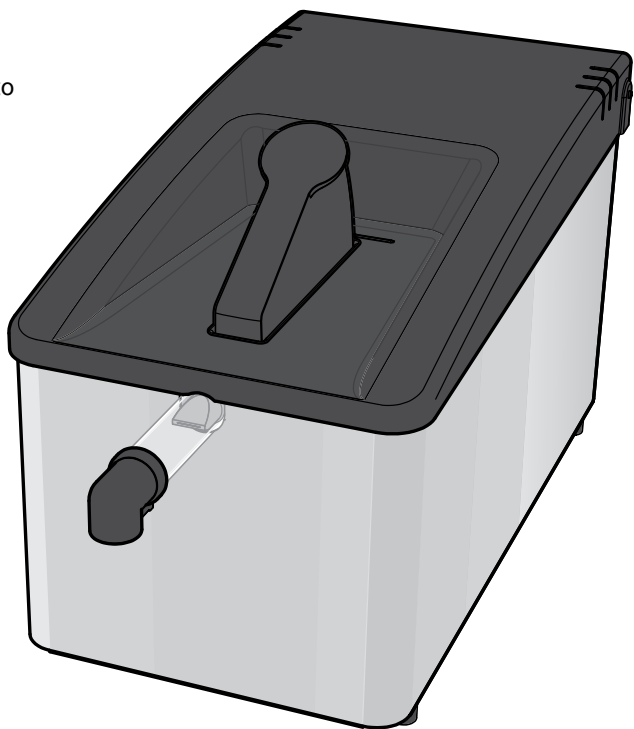

Thank You

for purchasing our Extreme™ Countertop Dispenser. This portion controlled, high-volume unit is sealed and sanitary, achieves excellent evacuation and has only a few parts for easy clean-up.

SIMPLIFY CONDIMENT MANAGEMENT— GO POUCHED

EXTREME™ DISPENSER PARTS

LEVER
07014

LID
07501

EVACUATION PLATE
07508

TORSION SPRING
07505

COTTERLESS HINGE PIN
81105

ROLLER
07056

HINGE PIN
07161

PROTECTIVE CORNERS (2)
07644

PROTECTIVE CAP (4)
86337

SERIES 07H
FOOT W/SCREW (4)
81058

SERIES 23A
FOOT - PUSHED IN (4)
92098

PUMP
07518

11" BRUSH
82049

PUMP PARTS

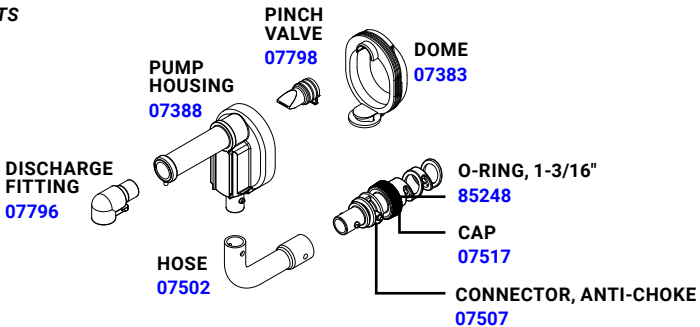

SAFETY



According to food and safety regulations, most foods must be stored and/or served at certain temperatures or they could become hazardous. Check with local food and safety regulators for specific guidelines. Server Products, Inc. cannot be responsible for the serving of potentially hazardous product.

IMPORTANT

Clean, rinse, sanitize, and dry parts daily or regularly to comply with local sanitization requirements.



NSF International lists this pump as:
"Not acceptable for dispensing potentially hazardous foods."

ADA
compliant

PORTION CONTROL

MAXIMUM PORTION IS
1 OZ PER PUSH

Adjustable in 1/4 oz increments

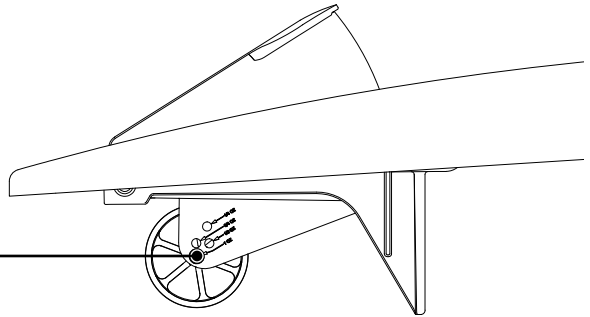

Hinge pin attaches roller to lever.
(Controls portion dispensed.)

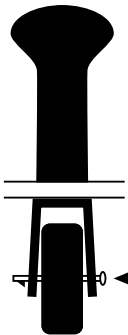

Install hinge pin through center
roller hole and desired portion
hole on lever.
Pin snaps into place.

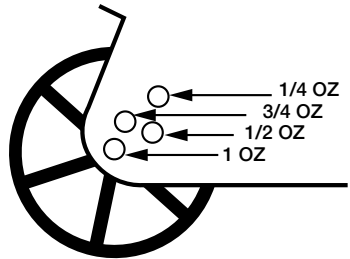

PUMP ASSEMBLY

WASH ALL PARTS
PROPERLY BEFORE USE. See page 7.

- 1** INSERT PINCH VALVE
into pump housing.

TIP: Squeeze the pinch valve open before installation to ensure it isn't stuck shut.

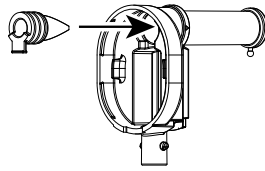

- 2** INSTALL DOME

Press dome into housing fully. Ensure valve flap covers bottom opening.

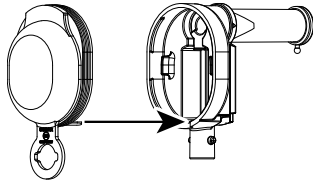

Wrap loop around lower opening to secure dome.

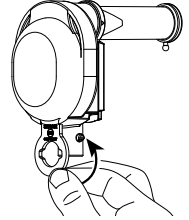

- 3** INSTALL TUBE

Lubricate with a small amount of clean water. Rotate and position until both pegs on housing fit into holes on tube.

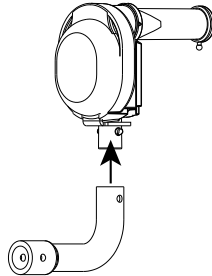

- 4** INSERT CONNECTOR

Lubricate connector with a small amount of clean water. Rotate and position until both pegs on connector fit into holes on tube.

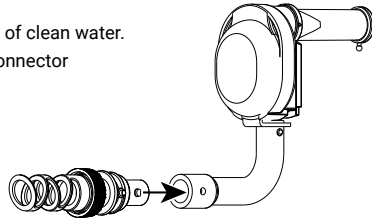

- 5** INSERT DISCHARGE FITTING

into pump housing discharge tube. Place loop of fitting around peg on end of discharge tube to secure.

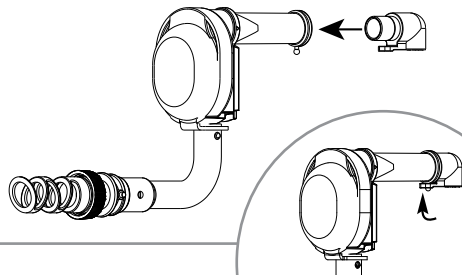

UNIT SETUP

WASH ALL PARTS
PROPERLY BEFORE USE. See page 7.

1 PREPARE POUCH

- Place condiment pouch on flat surface with circular pouch fitment facing upward.
- Remove pouch cap.

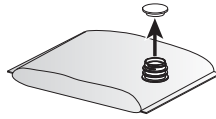

2 ATTACH POUCH TO PUMP

- Insert pump connector into pouch fitment.
- Rotate locking collar clockwise to secure.

TIP: Make pump priming even easier. Push condiment toward connector and squeeze pump dome several times until product is visible in pump.

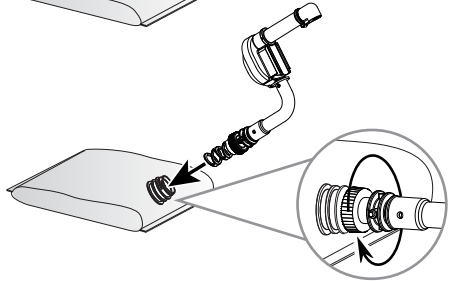

3 INSTALL PUMP & POUCH INTO UNIT

- Place pouch in rear compartment of unit.
- Slide pouch connector grooves into unit divider channel.
- Insert pump into slots inside front of unit.

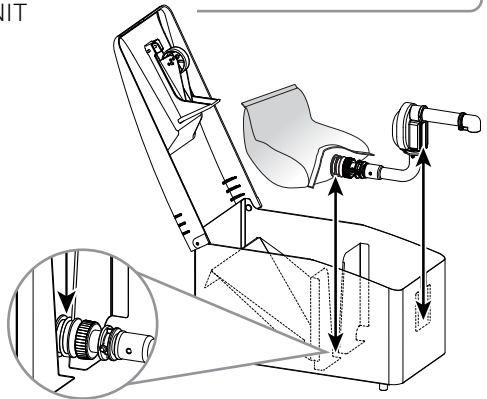

4 SECURE POUCH

- Fold two back corners of pouch over side walls.
- Close lid to secure pouch corners for best product evacuation.

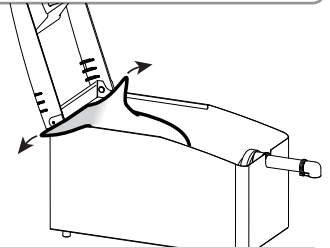

5 PRIME PUMP

Press lever several times until you see product in discharge tube.

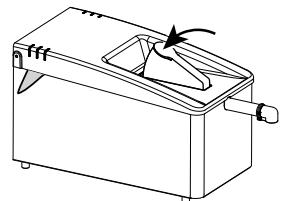

TAKE-DOWN & DISASSEMBLY

1 OPEN LID

2 REMOVE PUMP & POUCH

3 DETACH PUMP FROM POUCH

Rotate locking collar to release pouch.

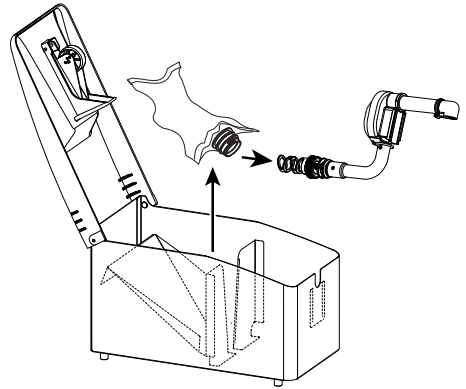

IMPORTANT: Only throw away empty pouch. **Keep the pump connector.**



4 FLUSH & RINSE PUMP

Place lower end of pump into container of hot water. Pump until all remaining product is expelled and only water flows from discharge tube.

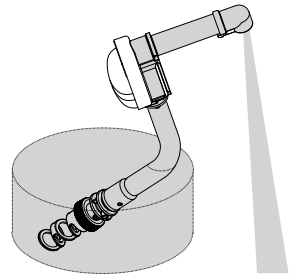

5 DISASSEMBLE PUMP

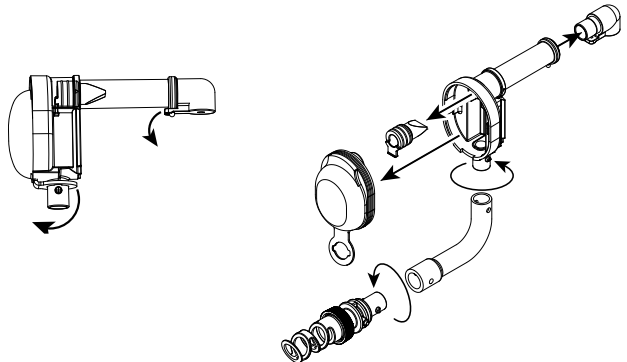

CLEANING

PUMP CLEANING

- 1 FLUSH & RINSE**
all pump surfaces with hot water. Place lower end of pump into container of hot water and operate pump until all remaining product is expelled and only hot water is discharged.
- 2 DISASSEMBLE & CLEAN**
all washable parts with soap and hot water. Use brush to clean any confined areas.
- 3 RINSE**
fully with clear water.
- 4 SANITIZE**
all parts according to local sanitization requirements. All parts in contact with food must be sanitized.
- 5 AIR DRY**
all parts fully.



YES!

Use dishwashing soap, hot water and nylon brush

- Pump is dishwasher safe
- Do not use abrasive, caustic or ammonia based cleansers.
- Do not use cleansing agents with high concentrations of acid, alkaline or chlorine.
- Do not use metal scrapers or cleaning pads that could scratch surfaces.

UNIT CLEANING

PLASTIC LID: Handwash Only

- External surfaces may be wiped clean with a clean damp cloth.
- Glass and surface cleaners approved for use in food contact areas may be used.
- Do not use abrasive, caustic or ammonia based cleansers.
- Do not use metal scrapers or cleaning pads that could scratch surfaces.

CARE OF STAINLESS STEEL

This unit is constructed with stainless steel— one of the best materials for food serving and storage.

If you notice corrosion beginning on any stainless steel surface, you may need to change the cleansing agent, sanitizing agent, or the cleaning procedures you are using.

- A mildly abrasive nylon or brass brush may be used to remove any stubborn food or mineral deposits on interior surfaces of unit.
- Fully rinsing and drying all parts can help prevent corrosion. Elements and minerals in tap water can accumulate on stainless steel parts and create corrosion.
- Do not use products containing acids, alkalines, chlorine, or salt. These agents can corrode stainless steel.

TROUBLESHOOTING

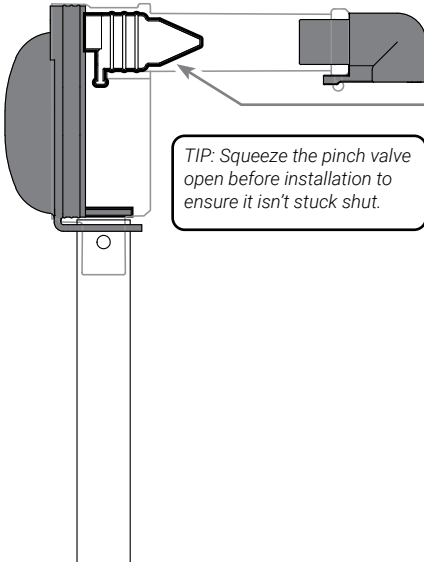

DIFFICULT TO ATTACH PARTS?

- Wet parts with clean water to help fit.

PRODUCT DOESN'T PUMP?

- Ensure pinch valve is inserted in housing.
- Ensure connector is snapped fully in place to fitment in pouch.
- Ensure pump is properly attached to pouch.
- Clean pump thoroughly.
- Ensure pump is properly installed into retaining slots inside front wall of shroud.

HOME POPS OFF?

- Clean thoroughly. Food residue could prevent a tight seal between dome and housing.
- Ensure dome edges are flush with housing.

SERVER PRODUCTS LIMITED WARRANTY

2
YEAR
WARRANTY

This Server product is backed by a two-year limited warranty against defects in materials and workmanship. See Server-Products.com for details.

GENERAL SERVICE, REPAIR OR RETURNS

Before sending any item to Server Products for service, repair, or return, contact Server Products customer service to request a **Return Authorization Number**. Merchandise must be sent to Server Products with this number. Service is extremely prompt. Typically, units are repaired and ship out within 48 hours of receipt.

Merchandise being returned for credit must be in new and unused condition and not more than 90 days old and will be subject to a 20% restocking charge.

NEED HELP?

Server Products Inc.

3601 Pleasant Hill Road
Richfield, WI 53076 USA

Chat with us!

spsales@server-products.com

262.628.5600 | 800.558.8722

Please be prepared with your **Model, P/N** and **Series** located on the lid or base of the unit.

Example:

MODEL XXXX	NSF _®	SERIES ##X ##X
P/N #####		

SERVER
INTELLIGENT BY DESIGN