

First in Cooking, Built to Last.

southbend

A MIDDLEBY COMPANY

IMPORTANT FOR FUTURE REFERENCE

Please complete this information and retain this manual for the life of the equipment:

Model #: _____

Serial #: _____

Date Purchased: _____

OPERATOR'S MANUAL

Super Simple Steam

SEZ Series Countertop Steamers

Models SEZ-3 & SEZ-5

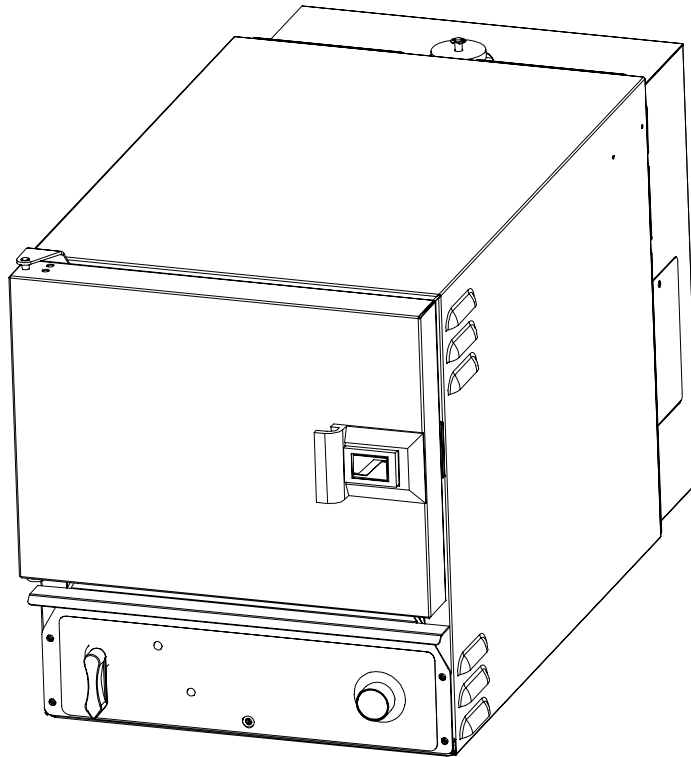

Model SEZ-3

! WARNING

Improper installation, operation, service, or maintenance can cause property damage, injury, or death. Read this manual thoroughly before installing and operating this equipment.

1100 Old Honeycutt Road, Fuquay-Varina, NC 27526
(800) 348-2558 or (919) 552-9161 • FAX (800) 348-2558 or (919) 552-9798

MANUAL 1181587
\$18.00



COUNTERTOP STEAMER
MANUAL SECTION ST

SAFETY PRECAUTIONS

Before installing and operating this equipment, be sure everyone involved in its operation is fully trained and aware of precautions. Accidents and problems can be caused by failure to follow fundamental rules and precautions.

The following symbols, found throughout this manual, alert you to potentially dangerous conditions to the operator, service personnel, or to the equipment.



This symbol warns of immediate hazards which will result in severe injury or death.



This symbol refers to a potential hazard or unsafe practice which could result in injury or death.



This symbol refers to a potential hazard or unsafe practice which could result in injury, product damage, or property damage.



This symbol refers to information that needs special attention or must be fully understood, even though not dangerous.

WARNING **FIRE HAZARD**

For your safety, do not store or use gasoline or other flammable vapors and liquids in the vicinity of this or any other appliance.

Keep area around appliances free and clear of combustibles.

WARNING **SHOCK HAZARD**

Do not open panels that require use of tools.

Unit must be cleaned daily and properly maintained to reduce chances of unsafe operating conditions.

WARNING **BURN HAZARD**

Stand back when opening doors - hot steam or hot water may escape from steamer.

NOTICE

Be sure this Operator's Manual and important papers are given to the proper authority to retain for future reference.

Congratulations! You have purchased one of the finest pieces of heavy-duty commercial cooking equipment on the market.

You will find that your new equipment, like all Southbend equipment, has been designed and manufactured to meet the toughest standards in the industry. Each piece of Southbend equipment is carefully engineered and designs are verified through laboratory tests and field installations. With proper care and field maintenance, you will experience years of reliable, trouble-free operation. **For best results, read this manual carefully.**

RETAIN THIS MANUAL FOR FUTURE REFERENCE.

Table of Contents

Specifications.....	4
Installation.....	6
Operation.....	12
Cooking Hints.....	13
Cleaning.....	16
Troubleshooting.....	18
Parts.....	40

Read these instructions carefully before attempting installation. Installation and initial startup should be performed by a qualified installer. Unless the installation instructions for this product are followed by a qualified service technician (a person experienced in and knowledgeable with the installation of commercial gas an/or electric cooking equipment) then the terms and conditions on the Manufacturer’s Limited Warranty will be rendered void and no warranty of any kind shall apply.

In the event you have questions concerning the installation, use, care, or service of the product, write to:

Technical Service Department
 Southbend
 1100 Old Honeycutt Road
 Fuquay-Varina, North Carolina 27526 USA

The serial plate is located on the right side of the unit near the back and top.



SPECIFICATIONS

DIMENSIONS

Figure 1

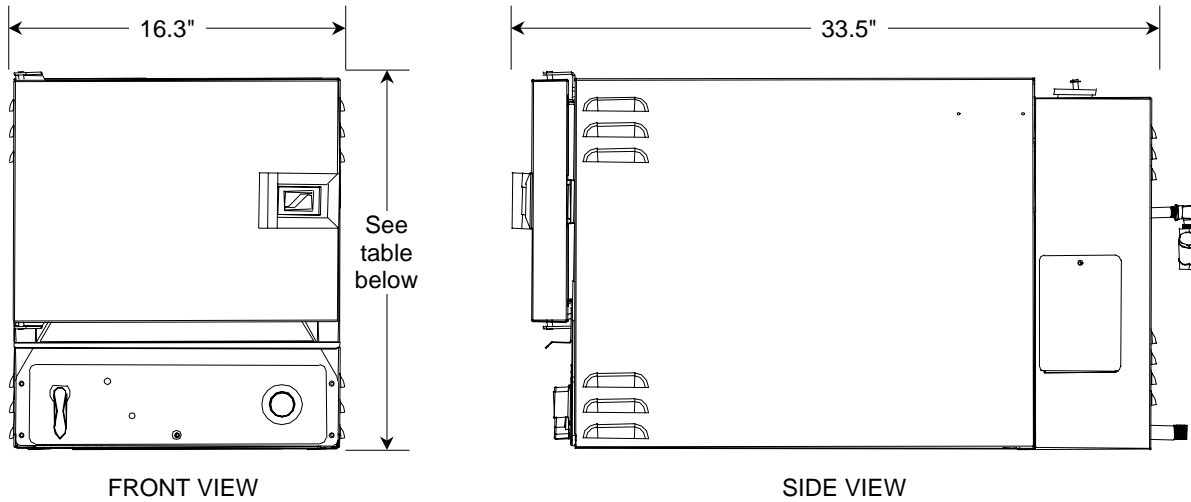

REAR VIEW

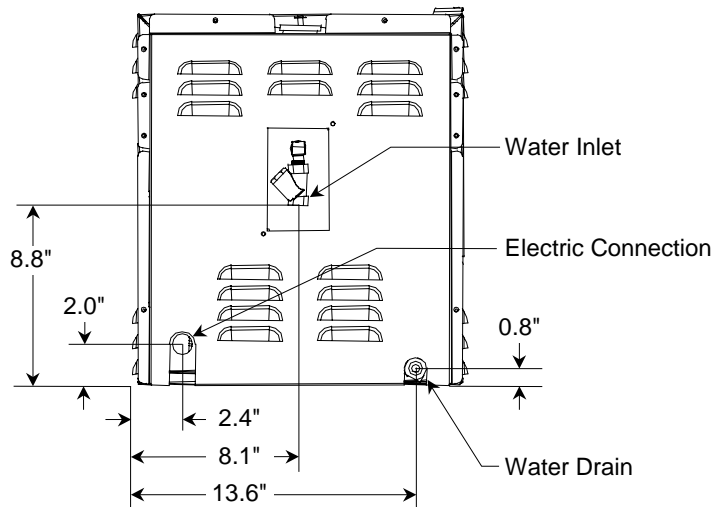

Model	Overall Height	Interior Dimensions			Pan Capacity*			Crate Dimensions			Crated Weight
		Width	Depth	Height	1"	2.5"	4"	Width	Depth	Height	
SEZ-3	18.1"	13.5"	22.0"	9.5"	6	3	2	19.5"	31.5"	28.5"	150 lbs.
SEZ-5	24.1"	13.5"	22.0"	15.5"	9	5	3	19.5"	31.5"	34.5"	175 lbs.

* "Pan Capacity" is the number of 1", 2.5", or 4" high standard pans (12" wide x 20" deep) that the steamer will hold.



ELECTRIC REQUIREMENTS

One electric connection is required to the fuse block of the steamer. All units shipped per customer order, three phase or single phase (a kit is available for field conversion to three phase or single phase). Circuit must be wired for the maximum amps at required voltage.

Voltage	Total Connected Amps			
	Model SEZ-3		Model SEZ-5	
	1 Phase	3 Phase	1 Phase	3 Phase
208 V	44	25	57	33
220 V	41	24	54	31
240 V	38	22	49	29
480 V	19	11	25	15

WATER REQUIREMENTS

To meet warranty requirements, the water supply must be as follows:

Connection	1/4" NPT (female) cold water
Pressure	30 to 60 PSI
Total Dissolved Solids (TDS)	60 PPM
Hardness	2 grains or 35 PPM
pH	7.0 to 7.5

Typical usage is 0.02 gpm. Maximum instantaneous usage is 0.12 gpm.

In order to minimize service problems and to meet the warranty requirements, a water treatment system (softener) is recommended when water quality does not meet the limits stated above.

DRAIN REQUIREMENTS

The drain outlet has a 3/8" NPT (male) connector. DO NOT directly connect the drain to a plumbing system unless you also install an "open funnel" downstream of this connection. There must be no back-flow or back-pressure into the drain connection!

CONSTRUCTION SPECIFICATIONS

Exterior: Type 304 stainless steel with #3 sanitary finish.

Interior: #304 stainless steel.

Power Source: One electric power source for controls and heating elements, as well as one ground wire. A positive ground connection is essential.

Cooking Compartment: Fully insulated.

CONTROLS

ON/OFF Lever: In the "OFF" position, the power is off and the drain valve is open. In the "ON" position, the power is on and the drain valve is closed.

60 Minute Timer: Time can be set between 1 and 60 minutes. When time expires, buzzer sounds. Buzzer can be disabled by turning the knob to manual position. Timer has no effect on the operation of the steamer.

"SERVICE REQUEST" Light: Unit signals when service is needed.

"ON" Light: Indicates power is on.



INSTALLATION

CAUTION

Do not locate unit adjacent to any high heat or grease producing piece of equipment, such as a range top, griddle, fryer, etc., that could allow radiant heat to raise the exterior temperature of the steamer body above 130°F (54°C). DO NOT MOUNT ABOVE OTHER COOKING EQUIPMENT.

NOTICE

These installation procedures must be followed by qualified personnel or warranty will be void.

Local codes regarding installation vary greatly from one area to another. The National Fire Protection Association, Inc. states in its NFPA 96 latest edition that local codes are the “authority having jurisdiction” when it comes to installation requirements for equipment. Therefore, installations should comply with all local codes.

The unit, when installed, must be electrically grounded and comply with local codes, or in the absence of local codes with the National Electrical Code ANSI/NFPA 70-latest edition.

Canadian installation must comply with CSA-Standard (C22.2 No. 109-M1981 General Requirements-Canadian Electrical Code, Part II. 109-M1981) Commercial Cooking Appliances.

NOTICE

EXHAUST FANS AND CANOPIES: It is recommended that the steamer be installed under a ventilation hood. Consult local codes for proper installation of hoods. Proper ventilation is the owner’s responsibility. Any problem due to improper ventilation will not be covered by warranty.

LEVELING: Unit must be level to assure maximum performance. Improper leveling may void warranty.

Step 1: Unpacking

IMMEDIATELY INSPECT FOR SHIPPING DAMAGE

All containers should be examined for damage before and during unloading. The freight carrier has assumed responsibility for its safe transit and delivery. If damaged equipment is received, either apparent or concealed, a claim must be made with the delivering carrier.

Apparent damage or loss must be noted on the freight bill at the time of delivery. The freight bill must then be signed by the carrier representative (Driver). If the bill is not signed, the carrier may refuse the claim. The carrier can supply the necessary forms.

A request for inspection must be made to the carrier within 15 days if there is concealed damage or loss that is not apparent until after the equipment is uncrated. The carrier should arrange an inspection. Be certain to hold all contents plus all packing material.



Step 2: Installation

1. Uncrate carefully. Report any hidden damage to the freight carrier IMMEDIATELY.
2. Do not remove any tags or labels until unit is installed and working properly.
3. If unit is to be installed on legs, locate legs and install as shown in Figure 2 below.

Figure 2

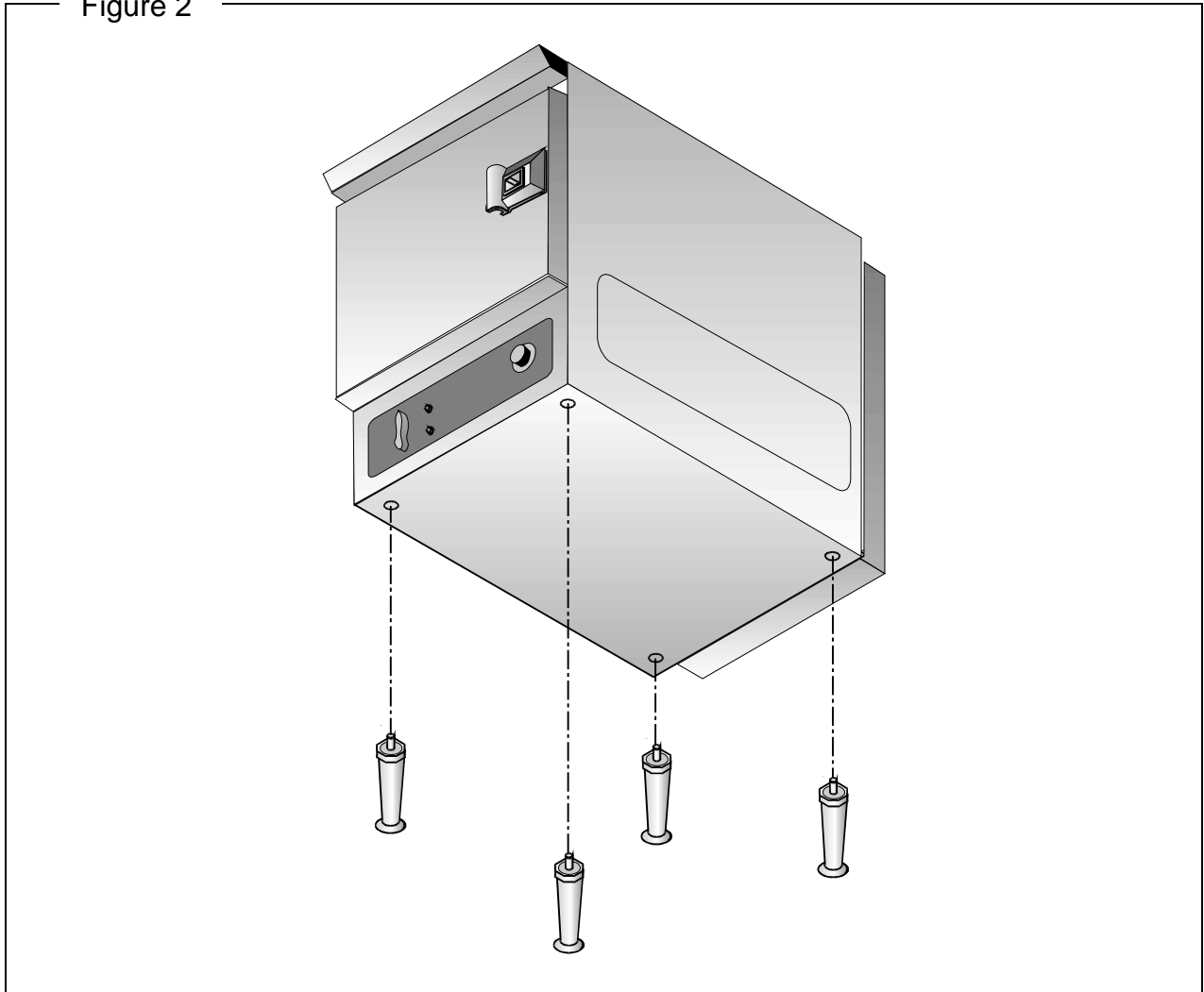

INSTALLATION

4. If the unit is to be installed on a counter top or other surface without using legs, the unit must be sealed to the surface to prevent any water, grease, etc., from accumulating under the steamer. The steamer can be bolted to the counter but will still have to be sealed. The installer may use G.E. or Dow Corning RTV type sealant. Consult local code for exact requirements. See Figure 3 below.



Figure 3

INSTALLATION

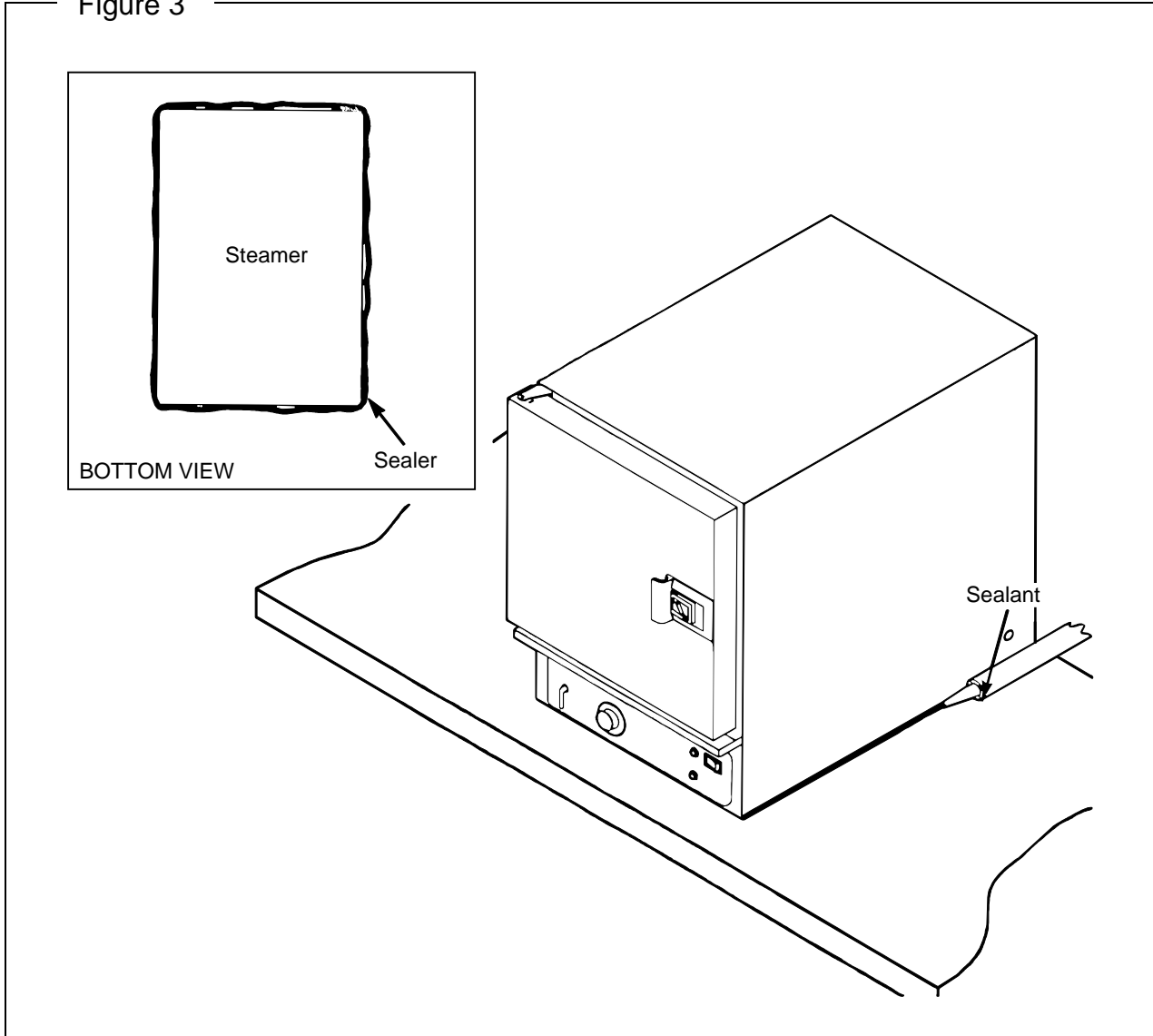



Step 3: Electric Connection

A field connection Fuse Block is located at the rear of the unit, lower left side when facing the back of the unit (see Figure 4 below). A hole is provided for a 3/4" conduit fitting (solid or flex). The rear cover must be removed to gain access to fuse block (see Figure 9 on page 26).

Be sure that the input voltage matches the requirement on the serial plate. The unit is factory wired per customer order.

! WARNING

A POSITIVE GROUND CONNECTION IS ESSENTIAL. DO NOT ALLOW ANY TAMPERING OR ADJUSTMENT OF ANY CONTROL OR WIRING. THE UNIT IS FACTORY SET. ADJUSTING ANY INTERNAL COMPONENT OTHER THAN THE MAIN FUSE BLOCK CAN VOID THE WARRANTY.

THIS UNIT REQUIRES A KIT TO BE FIELD CONVERTED FROM THREE-PHASE TO SINGLE-PHASE OR VICE-VERSA. CONSULT FACTORY FOR PHASE CHANGES.

All 208-220-240 and 480 volt units will have three fuse block sections, "L1-L2-L3", for use with either 3-wire 3-phase or 2-wire, single-phase, 50 or 60 Hz.

Figure 4

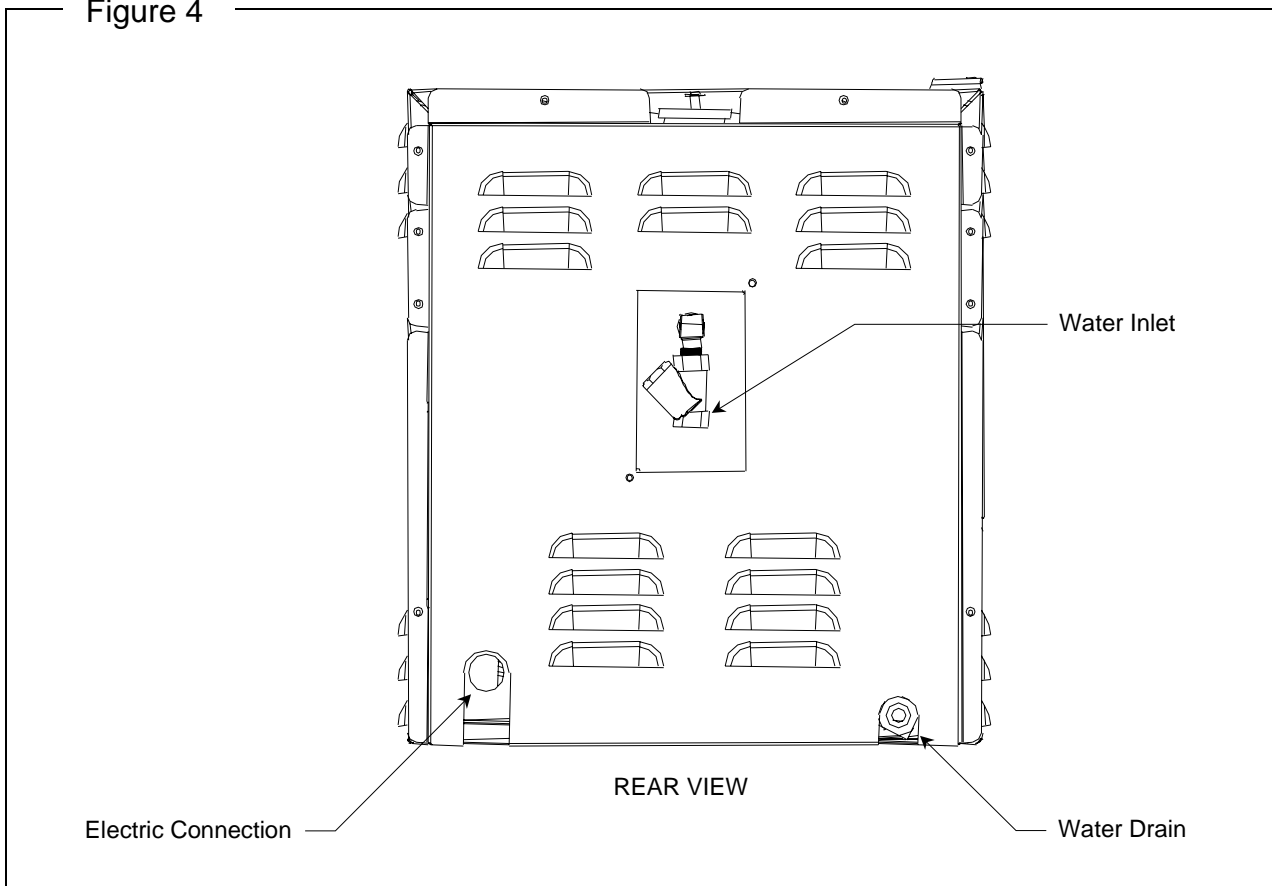

INSTALLATION



INSTALLATION

Step 4: Water Connection

! WARNING

Do not connect steamer to a hot water line. A hot water connection will damage the steamer.

NOTICE

To meet warranty requirements, the supply water must meet the following specifications:

Pressure	30 to 60 PSI
Total Dissolved Solids (TDS)	60 PPM
Hardness	2 grains or 35 PPM
pH	7.0 to 7.5

Connect a cold water line to the water inlet strainer on the back of the steamer, as shown in Figure 4 on page 9. The connector on the unit is 1/4" NPT female.

NOTE: To facilitate cleaning, and allow access to rear of unit, flexible connections are recommended. A shut off valve at (or near) the rear of the unit is highly recommended. See Figure 5 below.

Figure 5

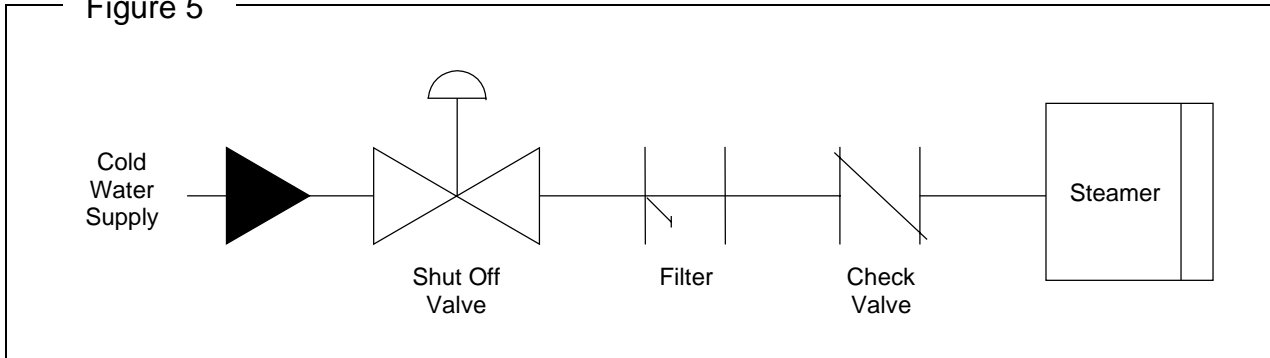



Step 3: Drain Connection

The drain outlet is located on the back of the steamer, as shown in Figure 4 on page 9. The drain connector on the unit is 3/8" NPT male.

Position the unit near, but not on top of, an open floor drain. DO NOT directly plumb to the unit unless you also install an "open funnel" downstream of this connection in the drain system. Make the drain line from the unit to the air gap above the "open funnel" as short as possible. There should be no horizontal piping between the unit and the air gap above the "open funnel." The "open funnel" is intended to eliminate any water from entering the steamer because of a blocked drain, and it also prevents any back pressure within the steamer cavity. Any connection that allows the build-up of back pressure in the unit (such as a reduction in pipe size to a line smaller than 3/8", or more than one 90-degree angle in the line prior to the "open funnel" drain discharge point) may cause personal or property damage and will therefore void the warranty. The unit is a pressureless, free-venting steam cooker and will not operate properly unless the drain line is short, at a steep angle, and open! See Figure 6 below.

Figure 6

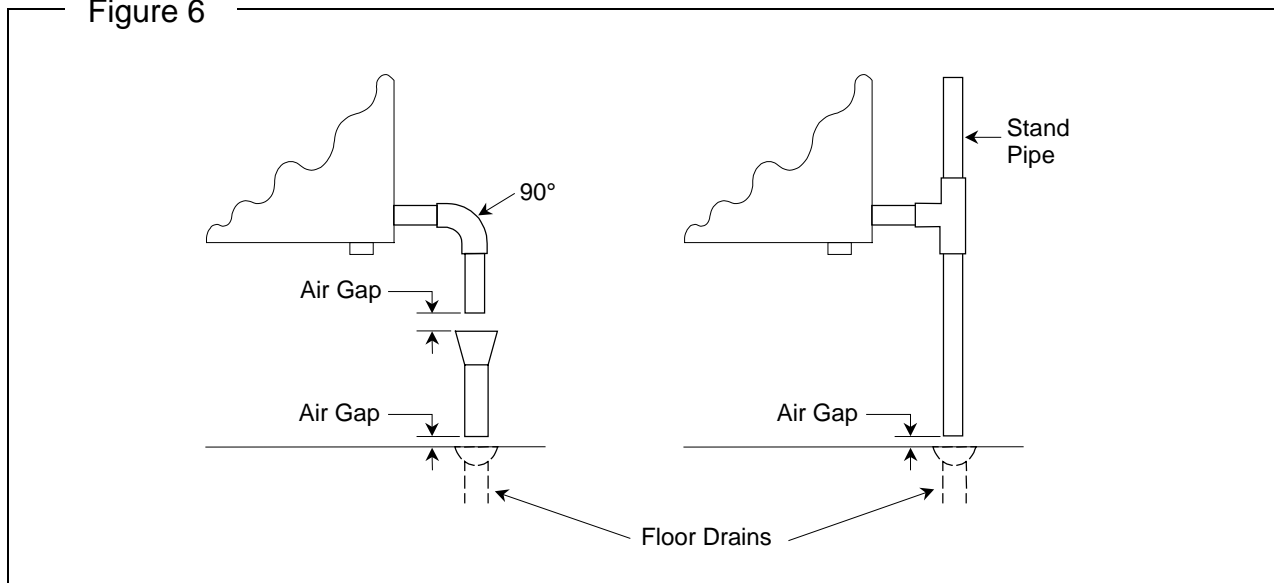



OPERATION

STARTUP

1. Turn lever to "ON" position.
2. Unit will fill automatically and be ready for operation in 15 minutes.

NOTICE: WATER SPECIFICATION

To meet warranty requirements, supply water must meet the following specification:

Total Dissolved Solids (TDS)	60 PPM
Hardness	2 Grains or 35 PPM
pH Factor	7.0 to 7.5

OPERATION

OPERATION

CAUTION

HOT STEAM WILL ESCAPE WHEN DOOR IS BEING OPENED. TO PREVENT BURNS KEEP HANDS AND FACE AWAY FROM STEAM.

If "SERVICE REQUEST" light illuminates during operation, contact your authorized service agency immediately.

1. Suggested cooking times for various foods are shown in the table in the following section.
2. Pan specifications are shown on specifications page (page 4).
3. The door may be opened or closed at any time.
4. Timer can be used as desired, but it has no effect on the operation of the unit!
5. Unit will automatically idle at operating temperature when and if the door is closed and there is no food in the cavity.

SHUTDOWN

1. Turn lever to the "OFF" position.
2. Remove pan guides.
3. Clean all interior surfaces with soap, water, and a non-metallic pad. Occasional use of a deliming solution such as Lime-A-Way is recommended. RINSE THOROUGHLY WITH CLEAN WATER.
4. Ensure drain opening is clear.
5. Replace pan guides.
6. Leave the door open at night after cleaning to prolong the life of the gasket.

NOTICE

DO NOT USE high-chlorine or bleach solution for cleaning the door gasket.

DO NOT USE steel wool or other metallic pads in the steamer.



COOKING HINTS

COOKING TIPS

Schedule cooking of fresh vegetables so that they will be served soon after they are cooked. If it is necessary to prepare them in advance, they can be plunged into cold water, drained thoroughly and held under refrigeration until needed for service.

Five pounds of cold cooked vegetables can be reheated in the steamer in 5 to 10 minutes, depending upon the variety.

SUGGESTED COOKING TIMES

Timer settings are for general guidance only. Differences in food quality, size, shape, freshness, load size, and desired degree of doneness must be taken into consideration and adjustments made in time, if necessary.

Product	Weight	Portions	Cooking Time (minutes)	Pan Used
Asparagus				
Fresh	3½ lbs.	14 (4 oz.)	8-10	Full/Perforated
Frozen Spears (Thawed)	5 lbs.	20 (4 oz.)	9	Full/Perforated
Beans				
Green - Frozen, Cut	5 lbs.	20 (4 oz.)	12	Full/Perforated
Green - Fresh	5 lbs.	20 (4 oz.)	15-17	Full/Perforated
Wax - Frozen	5 lbs.	20 (4 oz.)	13	Full/Perforated
Lima - Frozen	5 lbs.	20 (4 oz.)	10	Full/Perforated
Broccoli				
Spears - Fresh	4 lbs.	16 (4 oz.)	10-12	Full/Perforated
Spears - Frozen (Thawed)	5 lbs.	20 (4 oz.)	8	Full/Perforated
Brussel Sprouts				
Fresh	5 lbs.	20 (4 oz.)	15-17	Full/Perforated
Fresh	5 lbs.	20 (4 oz.)	13	Full/Perforated
Carrots				
Frozen - Whole Baby	5 lbs.	20 (4 oz.)	12	Full/Perforated
Fresh - ¼-inch Bias Cut	5 lbs.	20 (4 oz.)	12	Full/Perforated
Cabbage				
Green, Cut Into Wedges		24	15	Full/Perforated
Red, Cut Into Wedges		16	18-20	Full/Perforated
Cauliflower				
Fresh, Whole	2 lbs.	8 (4 oz.)	9-10	Full/Perforated
Fresh, Whole	2 lbs. 12 oz.	11 (4 oz.)	15	Full/Perforated
Frozen, Flowerettes	5 lbs.	20 (4 oz.)	10-12	Full/Perforated
Corn				
Fresh, Cob, 4-5 Inch Ears	5½ lbs.	15	13-15	Full/Perforated
Frozen - Whole Kernel	5 lbs.	20 (4 oz.)	8	Full/Perforated
Frozen - Cob, 6 Inch Ears	9 lbs.	14	12-14	Full/Perforated

Table continues on next page.



Table continuing from previous page.

Product	Weight	Portions	Cooking Time (minutes)	Pan Used
Mixed Vegetables				
Frozen	5 lbs.	20 (4 oz.)	12	Full/Perforated
Peas				
Frozen	5 lbs.	20 (4 oz.)	8	Full/Perforated
Potatoes				
Red Bliss - Whole	7 lbs.	28	35	Full/Perforated
Russetts - Whole	8 lbs.	20	25-35	Full/Perforated
Russetts - Peeled	5 lbs.	12	20	Full/Perforated
Russetts 1-Inch Cubes	5 lbs.	20 (4 oz.)	17	Full/Perforated
Spinach				
Fresh, Leaf	2½ lbs.	10 (4 oz.)	5	Full/Perforated
Frozen, Chopped	6 lbs.	24 (4 oz.)	35	Full/Perforated
Zucchini				
Fresh - Slices ¼-inch Thick	5 lbs.	20 (4 oz.)	6-8	Full/Perforated
Broccoli				
Spears - Fresh	4 lbs.	16 (4 oz.)	10-12	Full/Perforated
Spears - Frozen (Thawed)	5 lbs.	20 (4 oz.)	8	Full/Perforated
Eggs				
Large - Hard Cooked	12 lbs.	12	15-16	½ Perforated
Meats				
Corned Beef	6¾ lbs.	18 (6 oz.)	2 hours	Full
Hot Dogs, Thawed	5 lbs.	40 (2 oz.)	5	Full/Perforated
Hot Dogs, Frozen	5 lbs.	40 (2 oz.)	10	Full/Perforated
Fowl				
Boneless Chicken Breast	4½ lbs.	12 (6 oz.)	15	Full/Perforated
Tamales, Frozen	3 lbs.	12 (4 oz.)	20	Full/Perforated
Tortilla, Frozen 8-Inch	4 Tortillas	4	45 Seconds	Half/Perforated
Beef Ravioli, Frozen	48 Ravioli (1 lb. 8 oz.)	8	5-6	Full/Perforated
Elbow Macaroni	2 lbs. Uncooked	32 (2 oz.)	7	In Perforated Pan Nested in Solid Pan
Spaghetti	2 lbs. Uncooked	32 (2 oz.)	14	In 4-Inch Full/Perforated
Egg Noodles	2 lbs. Uncooked	32 (2 oz.)	10	Full/Perforated
Converted Rice	2 lbs. 2½ Qts. Water + Oil & Salt		25	Full/Perforated
Navy Beans	2 lbs.			Full/Perforated
Place beans in pan and cover with 3-quarts hot tap water. Steam for 2 minutes; remove from steamer and cover for 1 hour. Remove cover and place back in steamer for 40 minutes.				

Table continues on next page.

COOKING HINTS



Table continuing from previous page.

Product	Weight	Portions	Cooking Time (minutes)	Pan Used
Black Eyed Peas Place beans in pan and cover with 3-quarts hot tap water. Steam for 2 minutes; remove from steamer and cover for 1 hour. Remove cover and place back in steamer for 35 minutes.	2 lbs.			Full/Perforated
Oysters	5 lbs.	16 Count	12	Perforated Pan Nested in Full Pan 2½-Inch Deep
Shrimp, Fresh, Medium, Heads Removed	5 lbs.		6-7	Full/Perforated
Shrimp, Frozen, Large, Peeled & Deveined	5 lbs.		8	Full/Perforated
Lobster	1¾ lbs.		8	Full/Perforated
Alaskan King Crab Legs	1 lb.		4-5	Full/Perforated
CherryStone Clams	5 lbs.	12	7	Full/Perforated
Fish Fillets	7½ lbs.	12 (10 oz.)	18	Full/Perforated Nested in Full Hotel Pan

- For eggs cooked in the shell, adding salt to the cooking water increases cooking efficiency and decreases cooking time. If the egg cracks, the white is cooked at the crack and is sealed right away.
- To avoid green yolk (which is a deposit of iron sulfide) chill the eggs immediately after removing from the steamer by plunging them into a cold water bath (preferably containing ice).
- A quick and easy way to cook eggs for a salad mixture is to crack them directly into a solid steam table pan which has been lightly coated with salad oil. Do not mix. Steam until they are hard cooked. Remove and chop as you would for egg salad. The job of peeling is eliminated.
- Transfer steamed hot chicken to deep pan, cover with Cacciatore Sauce and finish in oven. Bake 20 to 30 minutes. May be held on steam table.
- Chicken, sausage, and/or fish may be browned in Infra-Red or Radiant Broiler after steaming by brushing with melted margarine mixed with salad oil to give a golden brown color.
- Save juices from steamed chicken or turkey to make soups, sauces, or casserole dishes.
- Chicken may be steamed in advance and refrigerated for next day's use. Be sure to bring product back to 180°F before serving.
- Save the juice from the corned beef. After the cabbage has been steamed, place it in a solid pan and add the juice for flavoring and holding on a steam table.
- Steaming brisket is a definite time saver. Boiling in water takes 40 to 50 minutes per pound. Using the steamer can save 50% in cooking time.
- Cabbage, when steamed, retains its color and wedge identity. It will not break apart as it does when boiled in an open pot.
- When removing items prepared in a perforated pan, place a solid pan underneath the perforated pan with the cooked food in order to prevent dripping on the floor.
- The steamer is designed to accept standard 12" x 20" pans. Fractional size pans and dishes can be used as well with the optional perforated shelf.
- For stirring, the pan does not have to be removed from the steamer. Pull pan 1/3 way out of the cavity and the entire surface is accessible.
- The door may be opened at any time during operation to remove or add food.



CLEANING

Southbend equipment is constructed with the best quality materials and is designed to provide durable service when properly maintained. To expect the best performance, your equipment must be maintained in good condition and cleaned daily. Naturally, the frequency and extent of cleaning depends on the amount and degree of usage.

Following daily and more extensive periodic maintenance procedures will increase the life of your equipment. Climatic conditions (i.e., salt air, seasonings, and water quality) may result in the need for more thorough and more frequent cleaning in order to keep equipment performing at optimal levels.



WARNING: BURN HAZARD

For proper and safe operation, this steamer must be cleaned daily as described in this manual. Failure to do so could result in serious injury or damage.

Drains must be kept clean and clear of debris.



WARNING: SHOCK HAZARD

DO NOT GET WATER IN THE CONTROLS.

This could result in expensive repairs and/or electrical shock.

De-energize all power to equipment before cleaning the equipment.

CLEANING

DAILY CLEANING

1. Turn lever to the "OFF" position.
2. Remove pan guides.
3. Clean all interior surfaces with soap, water, and a non-metallic pad. Occasional use of a deliming solution such as Lime-A-Way is recommended. RINSE THOROUGHLY WITH CLEAN WATER.
4. Ensure drain opening is clear.
5. Replace pan guides.
6. Leave the door open at night after cleaning to prolong the life of the gasket.

NOTICE

DO NOT USE high-chlorine or bleach solution for cleaning the door gasket.

DO NOT USE steel wool or other metallic pads in the steamer.

PERIODIC CLEANING

- If lime or mineral deposits start to build up in the interior, clean the unit by using Southbend "descaler" or other non-caustic deliming solution. Follow manufacturer's recommended procedures. Thoroughly rinse out unit with clean water.
- To remove normal dirt, grease, or product residue from stainless steel, use ordinary soap and water applied with a sponge or cloth. Dry thoroughly with a clean cloth. **Never use vinegar or any corrosive cleaner.**



- To remove grease and food splatter or condensed vapors that have baked on the equipment, apply cleanser to a damp cloth or sponge and rub cleanser on the metal in the direction of the polishing lines on the metal. Rubbing cleanser as gently as possible in the direction of the polished lines will not mar the finish of the stainless steel. NEVER RUB WITH A CIRCULAR MOTION. Soil and burnt deposits which do not respond to the above procedure can usually be removed by rubbing the surface with SCOTCH-BRITE scouring pads. DO NOT USE ORDINARY STEEL WOOL, as any particles left on the surface will rust and further spoil the appearance of the finish. NEVER USE A WIRE BRUSH, STEEL SCOURING PAD, SCRAPER, FILE OR OTHER STEEL TOOLS. Surfaces which are marred collect dirt more rapidly and become more difficult to clean. Marring also increases the possibility of corrosive attack. Refinishing may then be required.

SEMIANNUAL CLEANING

At least twice a year, have your Southbend Authorized Service Agency or another qualified service technician clean and adjust the unit for maximum performance. Semiannual cleaning should include the following:

1. Add two gallons of deliming solution through the door into the cavity.
2. Turn unit on, let run for 30 minutes.
3. Turn unit off and drain all solution from the cavity.
4. Fill unit with clean water and drain. Repeat 2 times.

Consult the Southbend Authorized Parts/Service Distributor list for the Authorized Service Representative in your area or contact Southbend at 1-800-348-2558 for this information.

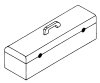

TROUBLESHOOTING

This section contains a troubleshooting key and referenced flowcharts to assist a qualified service technician in the servicing of an SEZ Series Countertop Steamer. **Please note that the unit has a “SERVICE REQUEST” light that illuminates in the event of certain water supply problems. Also note that when the unit is turned on, there is an eight-minute time delay before the heating elements come on to allow time for filling. Therefore, some procedures call for a waiting period when reconnecting power to the unit or turning the unit on.**

TROUBLESHOOTING KEY

Find the symptom below that corresponds to the malfunction, then turn to the corresponding figure and page. Follow the flowchart on that page until the problem is solved.

Symptom	Page
Unit Not Heating Up, “ON” Light Not Lit	19
Unit Not Heating Up Properly or Not Cooking Properly, “ON” Light Lit	20
Excessive Steam Coming from Pressure Relief Vent	21
“Service Request” Light Comes On During Operation	22
Buzzer Does Not Come On	23

TROUBLESHOOTING FIGURES AND PROCEDURES

Figure and/or Procedure	Page
Voltage Check at Control Panel Fuse Block	24
Heating Element Resistance Check (at Contactor)	25
Main Fuse Replacement	26
Power Switch Continuity Check	27
Contactor and MOV Check	28
Timer and Buzzer Check	29
Door Switch Continuity Check	30
Float Switch Continuity Check	31
Controller Check	32
Inlet Float Valve Check	33
Pressure Switch Check	34
High-Limit Thermostats Check	35
Electric Schematic for 208-240 Volt 60 Hz or 220 Volt 50 Hz Model SEZ-3	36
Electric Schematic for 480 Volt Model SEZ-3	37
Electric Schematic for 208-240 Volt 60 Hz or 220 Volt 50 Hz Model SEZ-5	38
Electric Schematic for 480 Volt Model SEZ-5	39

TROUBLESHOOTING

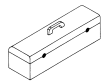

Unit Not Heating Up, "ON" Light Not Lit

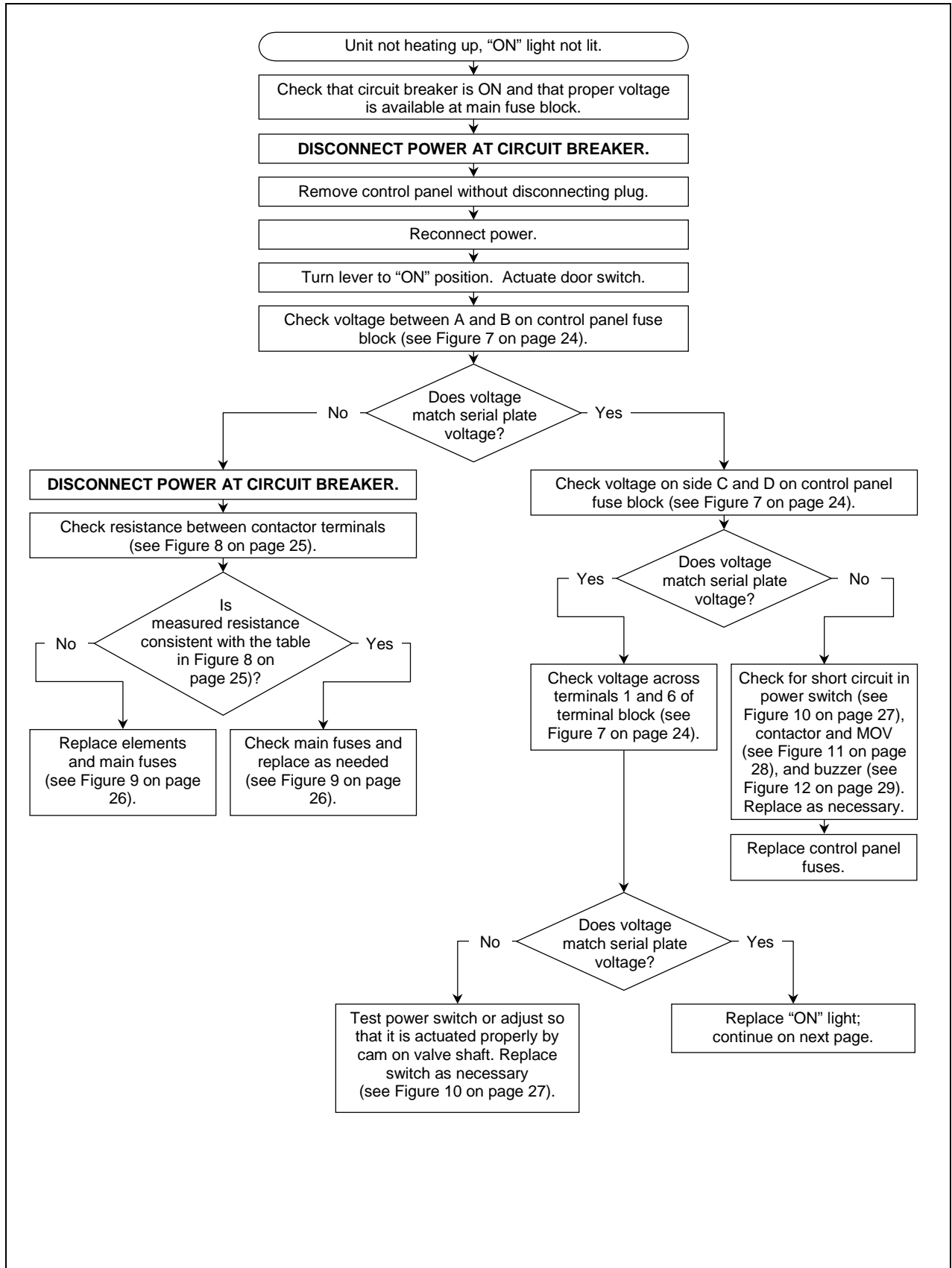

TROUBLESHOOTING



Unit Not Heating Up Properly or Not Cooking Properly, "ON" Light Lit

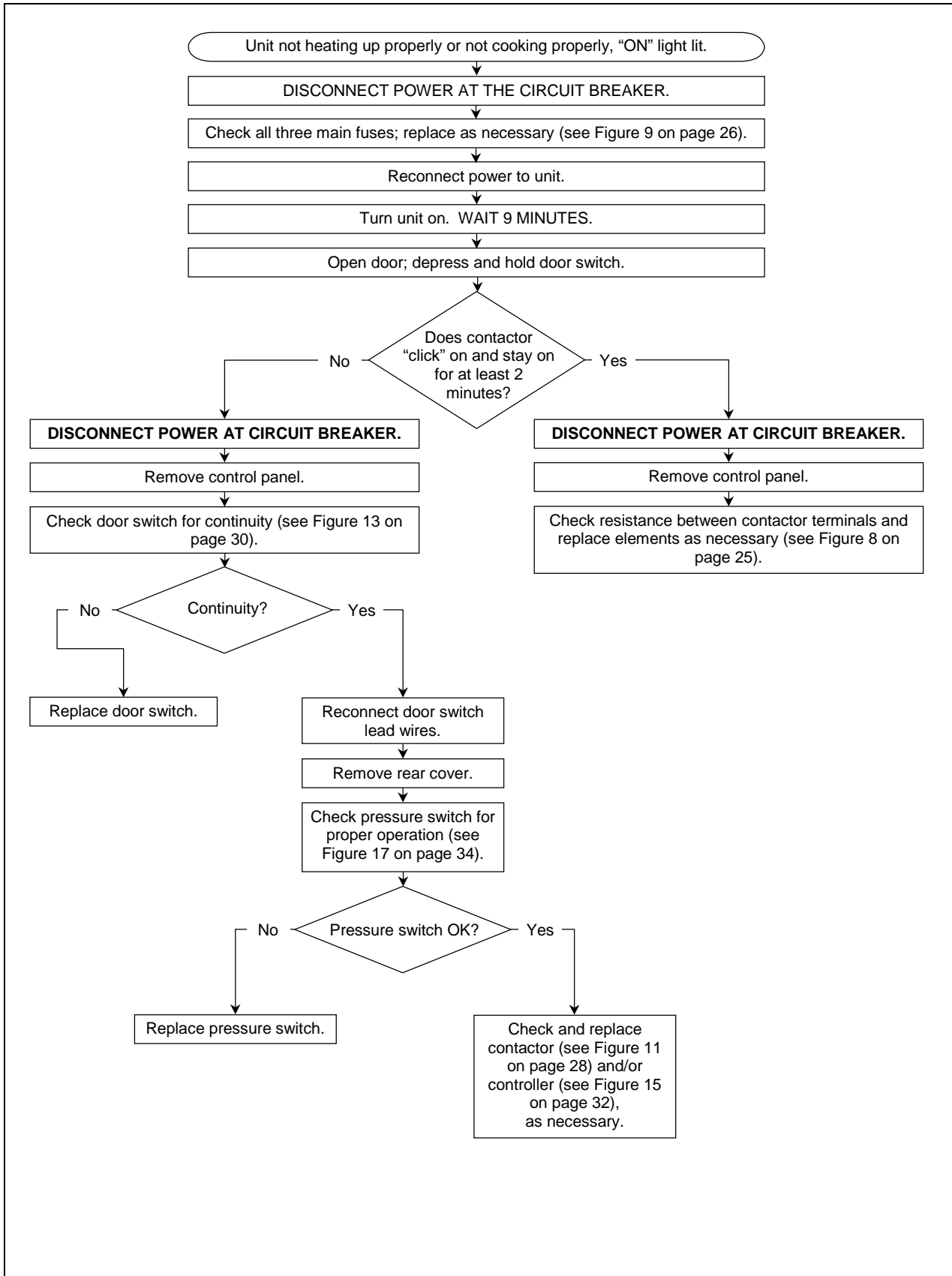

TROUBLESHOOTING

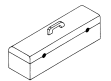

Excessive Steam Coming from Pressure Relief Vent

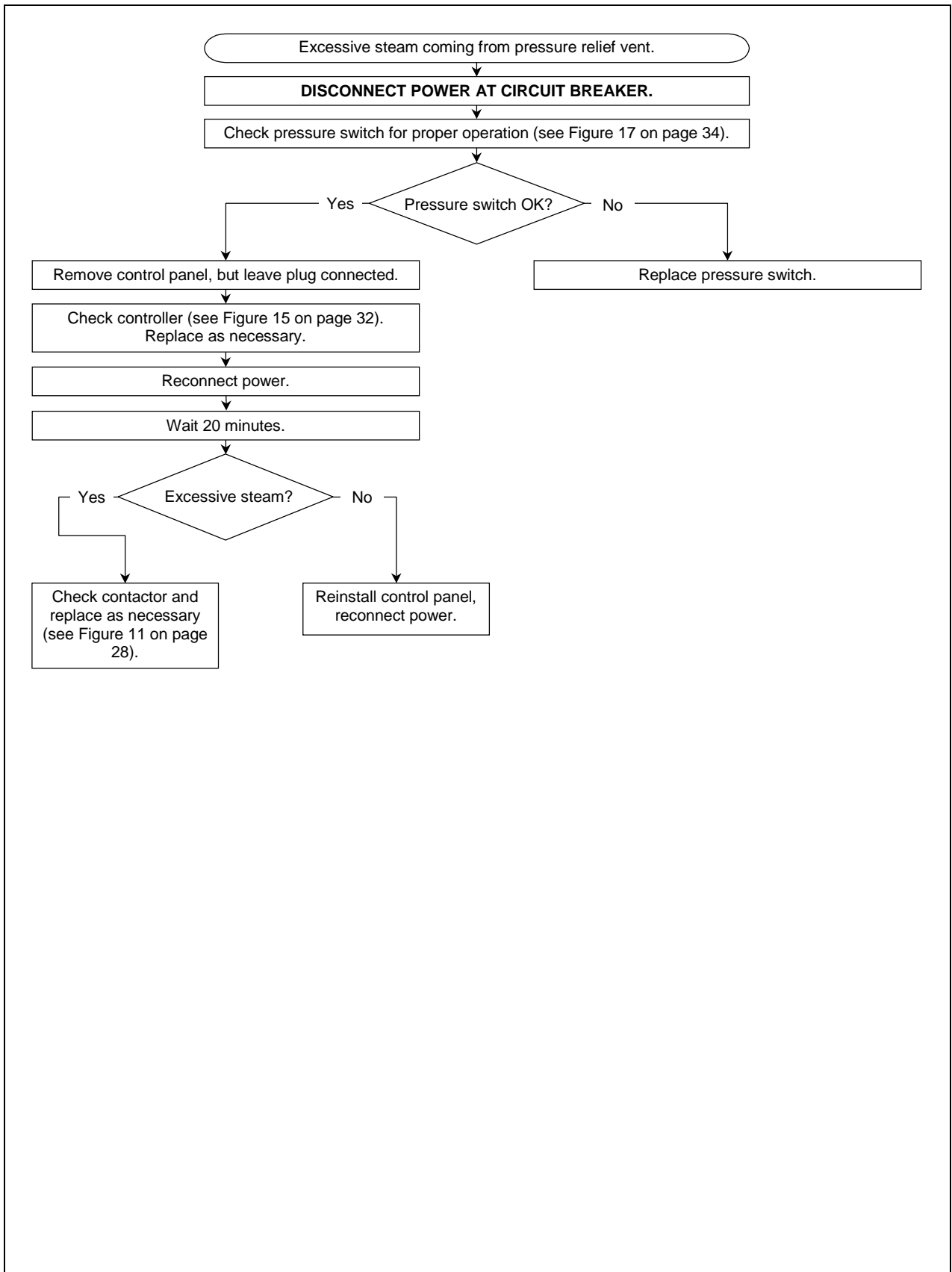

TROUBLESHOOTING



“Service Request” Light Comes On During Operation

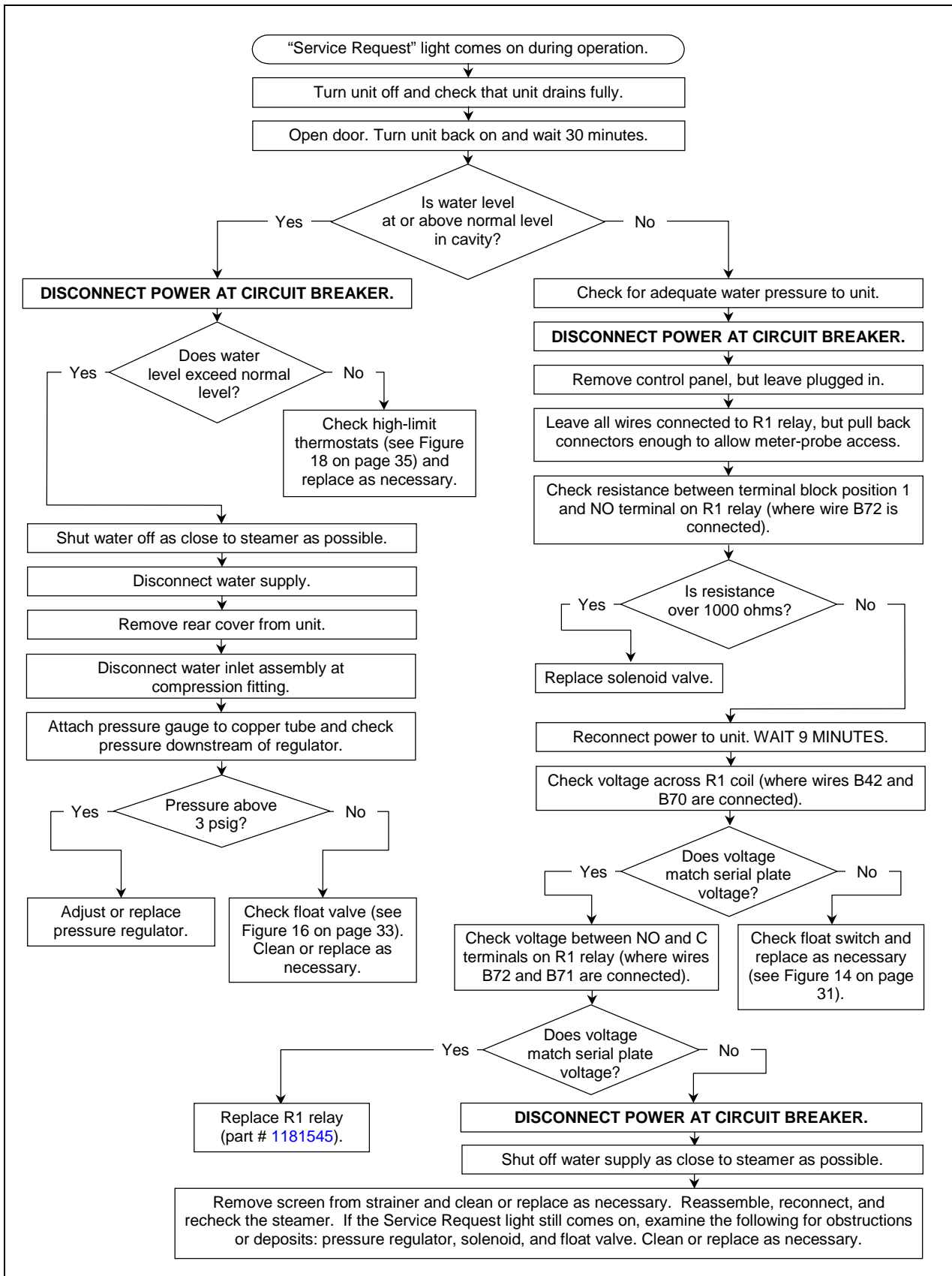

TRUBLESHOOTING

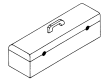

Buzzer Does Not Come On

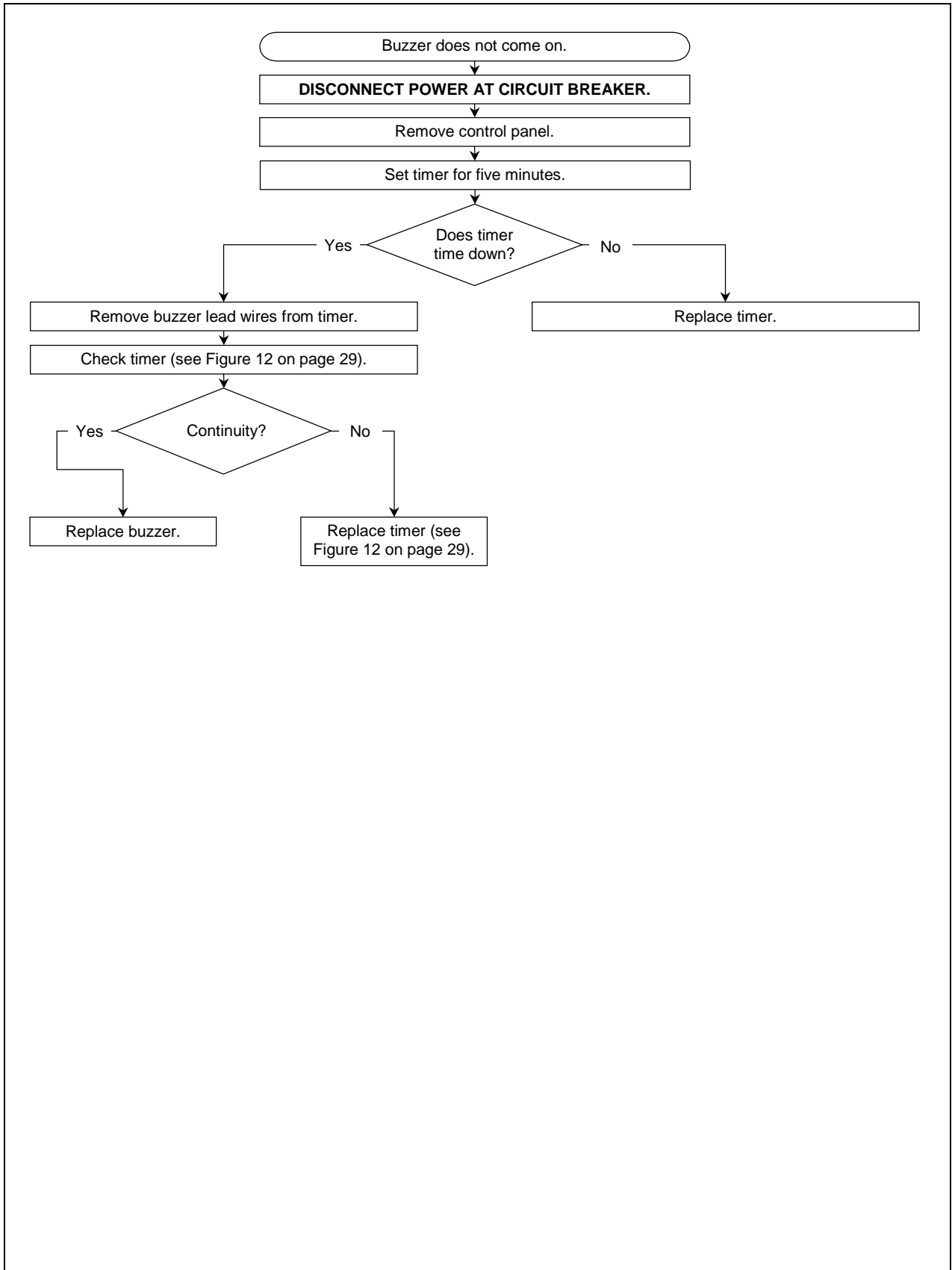

TROUBLESHOOTING



Figure 7

Voltage Check at Control Panel Fuse Block

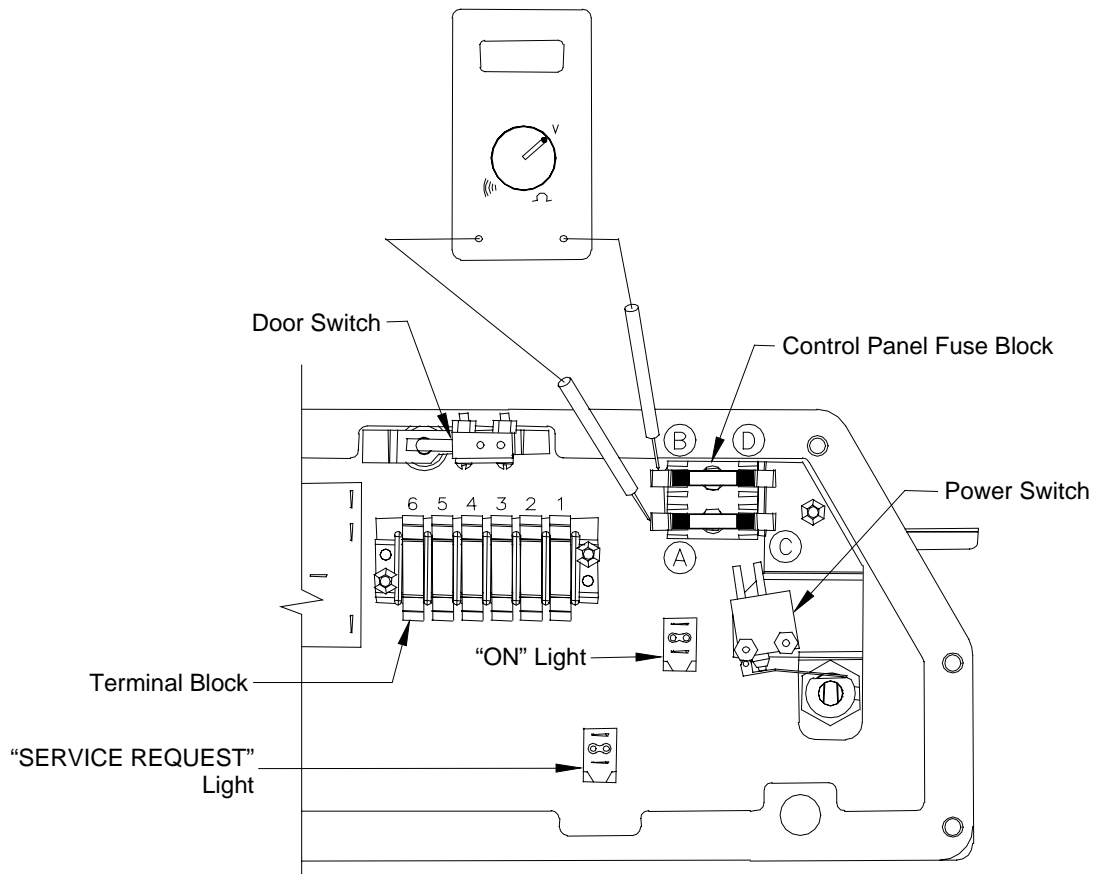

1. **DISCONNECT POWER AT CIRCUIT BREAKER.**
2. Remove control panel without disconnecting plug.
3. Turn lever to "ON" position.
4. Reconnect power.
5. Place leads as shown.
6. Check voltage.

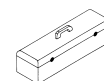
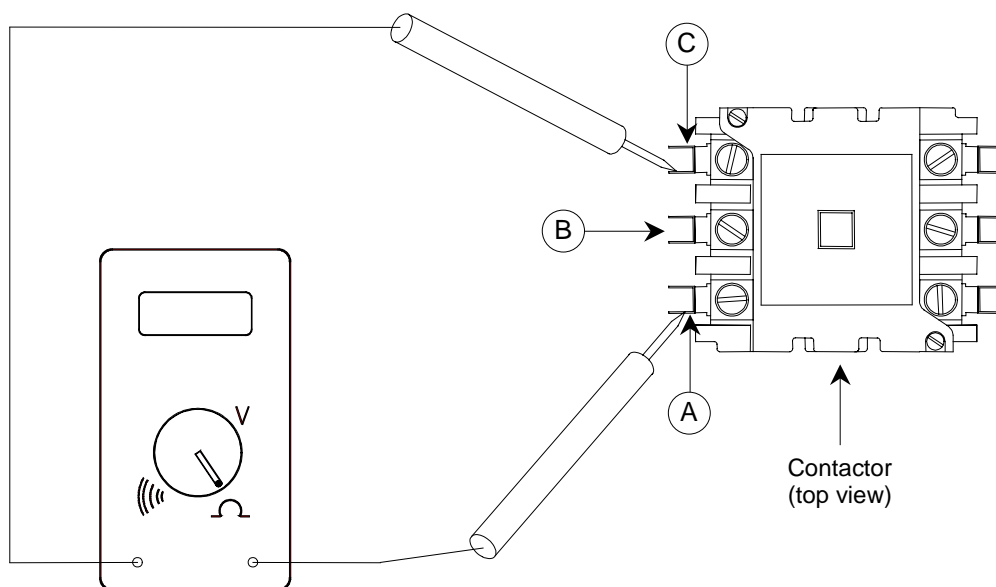

Figure 8

Heating Element Resistance Check (at Contactor)



1. **DISCONNECT POWER AT CIRCUIT BREAKER.**
2. Remove control panel.
3. **DO NOT REMOVE HEATING ELEMENT LEAD WIRES FOR THIS TEST.**
4. Place test leads between terminals A and C on left side of contactor.
5. Check the resistance and compare to the allowable range in the following table:

Voltage	Model SEZ-3			Model SEZ-5		
	Allowable Resistance (Ohms)			Allowable Resistance (Ohms)		
	Three-Phase		Single-Phase	Three-Phase		Single-Phase
	A-B or B-C	A-C	A-C	A-B or B-C	A-C	A-C
208	10 to 12	14 to 16	5 to 6	8 to 10	11 to 13	4 to 5
220	12 to 13	15 to 18	6 to 7	9 to 11	13 to 15	5 to 6
240	14 to 16	18 to 21	7 to 9	11 to 13	15 to 17	6 to 7
480	55 to 64	73 to 85	29 to 34	45 to 52	60 to 70	24 to 28

6. For three-phase units, check resistance between terminals A and B and between terminals B and C similarly.

TROUBLESHOOTING



Figure 9

Main Fuse Replacement

Shown with Rear Cover Removed

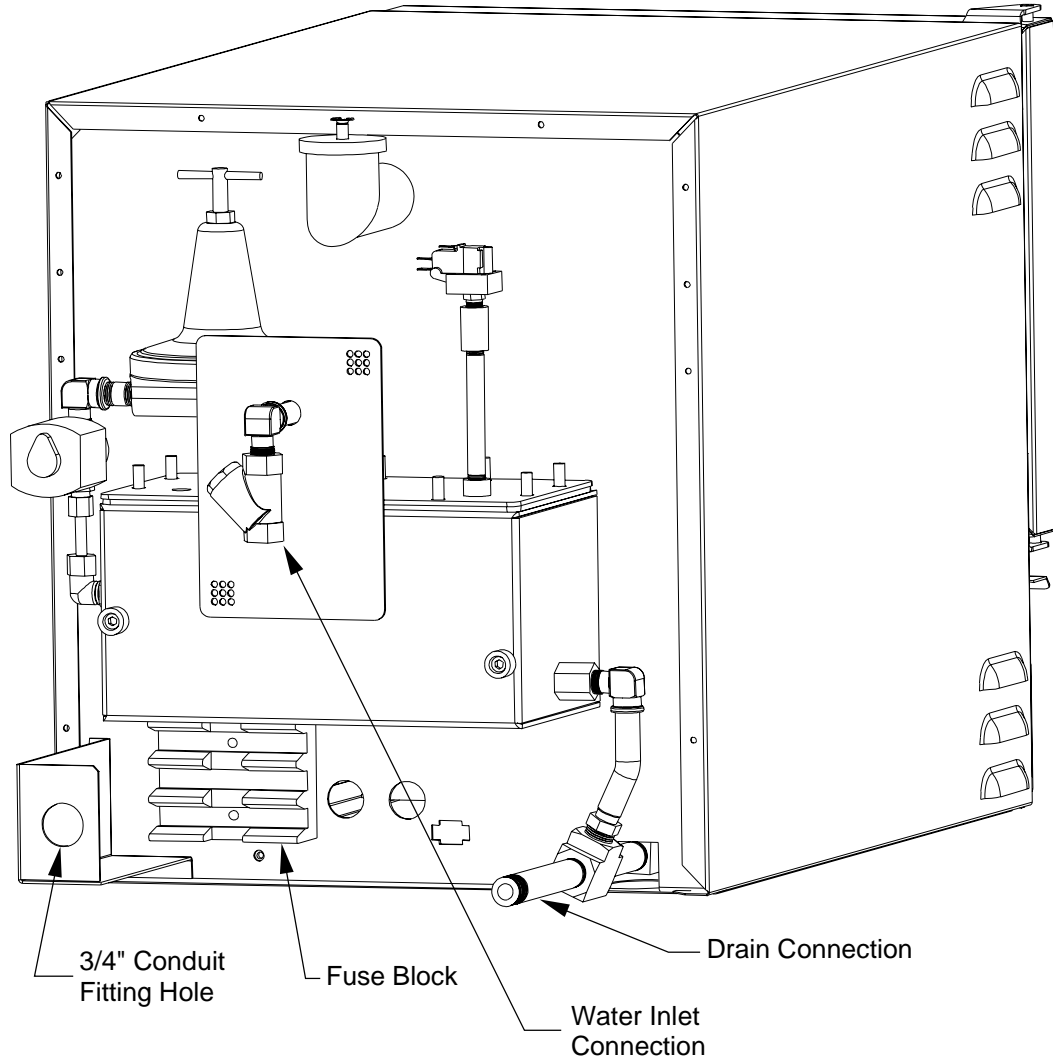

1. **DISCONNECT POWER AT CIRCUIT BREAKER.**
2. Remove rear cover from unit.
3. Check fuses for continuity.
4. Replace as necessary.

TROUBLESHOOTING



Figure 10

Power Switch Continuity Check

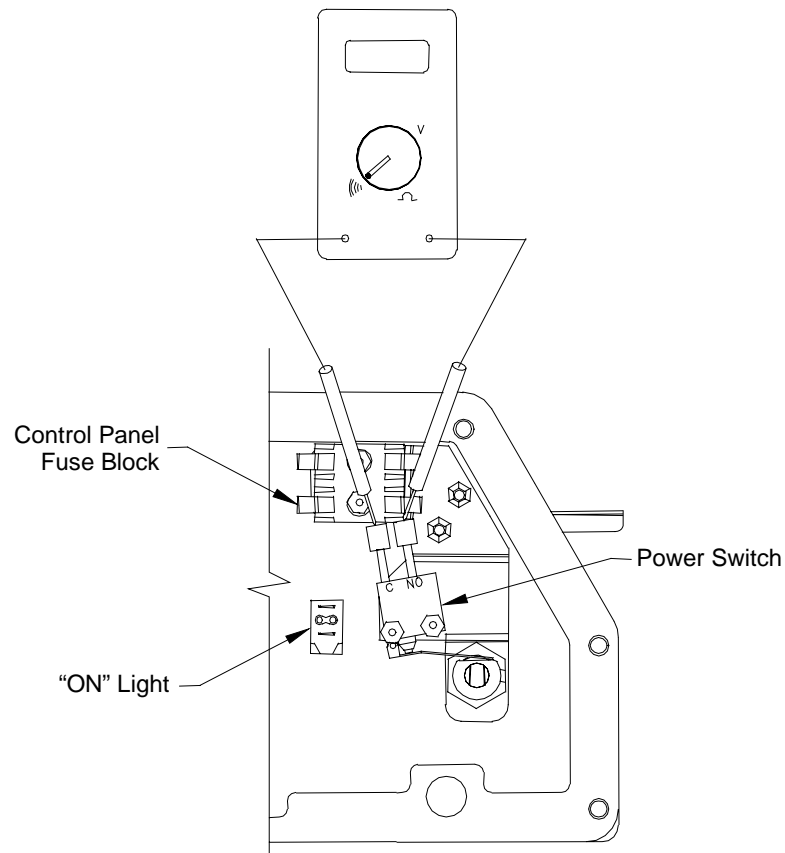

1. **DISCONNECT POWER AT CIRCUIT BREAKER.**
2. Remove control panel.
3. Turn Lever to "ON" from "OFF" and to "OFF" from "ON" ensuring that the power switch is properly actuated.
4. Remove power switch lead wires from fuse block (note wire locations).
5. Place test leads on "C" and "NO" lead wires as shown.
6. Check for continuity with lever in "OFF" position (there should be no continuity).
7. Check for continuity with lever in "ON" position (there should be continuity).
8. Repeat steps 5 - 7 with test leads between other pair of "C" and "NO" lead wires.
9. Place test lead on "NO" lead wire and other test lead on other "NO" lead wire.
10. Check for continuity with lever in "ON" position (there should be no continuity).
11. Reconnect wires or replace switch as necessary.



Figure 11

Contactor and MOV Check

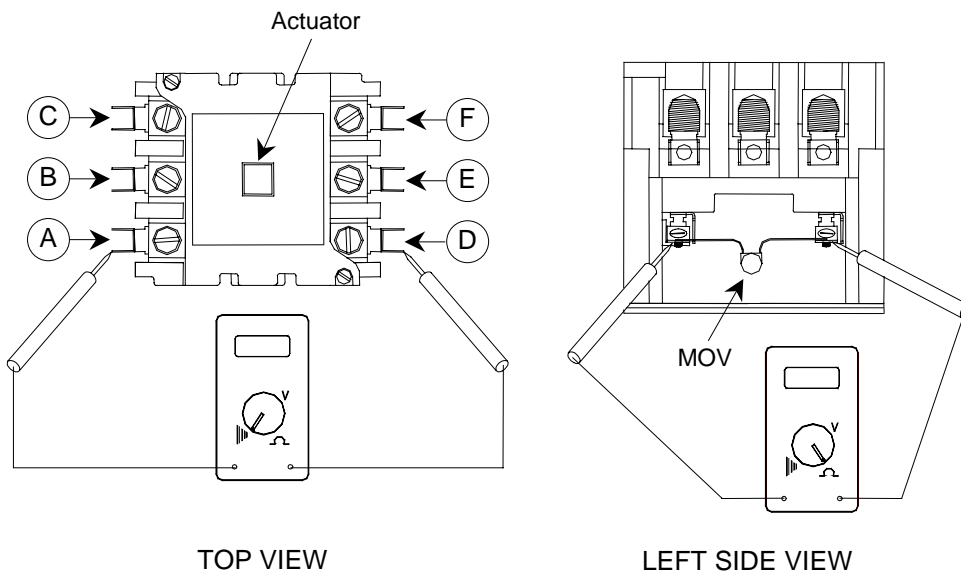

1. **DISCONNECT POWER AT CIRCUIT BREAKER.**
2. Remove control panel and disconnect nine-pin plug PL1.
3. Depress actuator on top of contactor. Actuator should travel freely and spring back when released.
4. Check for continuity between contacts A and D as shown in top view. There should be no continuity.
5. Repeat Step 4 for contacts B and E and for contacts C and F.
6. Remove wire C16 from contactor coil.
7. Place test leads on contactor coil terminal as shown in left side view.
8. Check resistance.
9. If resistance is not in the range 350 to 425 ohms, remove MOV and recheck coil resistance. If resistance is now in the range 350 to 425 ohms, replace MOV, otherwise replace contactor.
10. Reconnect all wires.

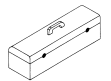
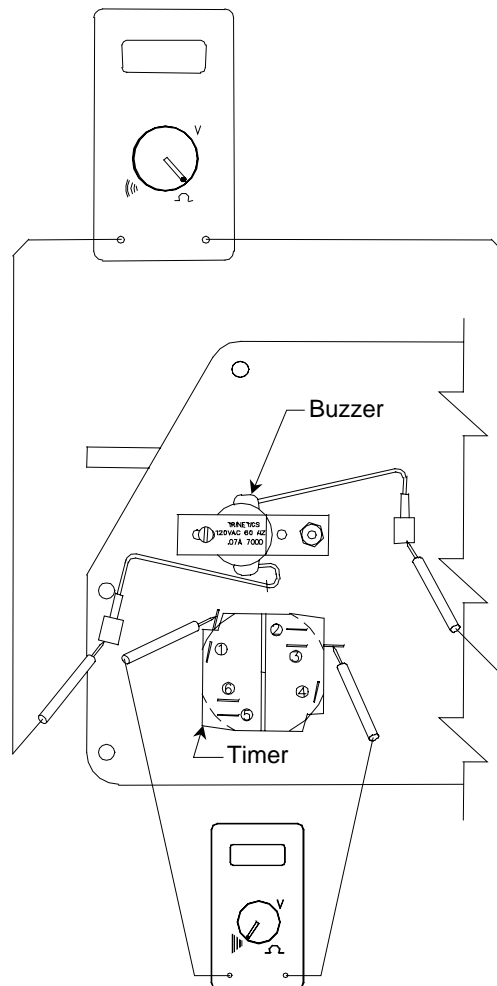

Figure 12

Timer and Buzzer Check



1. **DISCONNECT POWER AT CIRCUIT BREAKER.**
2. Remove control panel.
3. Set timer for one minute and allow to time out. If timer does not run, then replace.
4. Remove buzzer lead wires from timer and terminal block position 6.
5. Place test leads between positions 1 and 3 on the timer.
6. Check for continuity. If no continuity, replace timer.
7. Place test leads in terminals of buzzer lead wires.
8. Check that resistance is approximately 3.4 Kohms. Otherwise, replace buzzer.

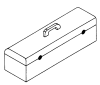
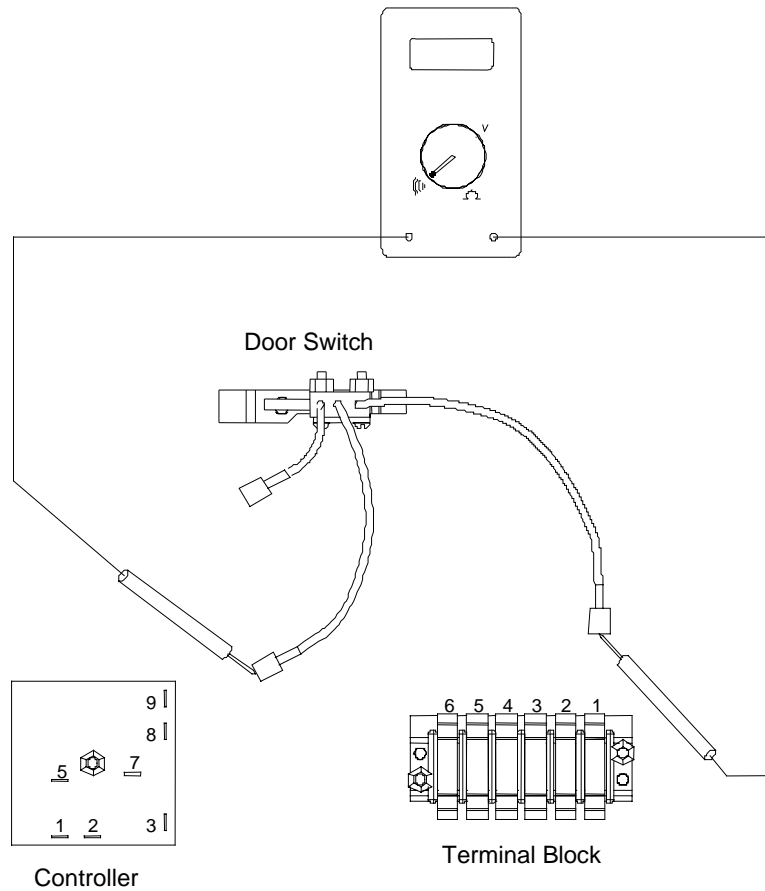

Figure 13

Door Switch Continuity Check



1. **DISCONNECT POWER AT CIRCUIT BREAKER.**
2. Remove control panel.
3. Depress and release door switch actuator rod to make sure door switch is properly actuated.
4. Remove door switch lead wires from terminal block position 1 and terminal 8 of the controller.
5. Place test leads as shown inside the terminal connectors of the lead wires.
6. Check for continuity - (there should be NO continuity).
7. Depress door switch actuator rod and check for continuity - (there should be continuity).
8. Replace as necessary.

TROUBLESHOOTING

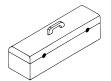
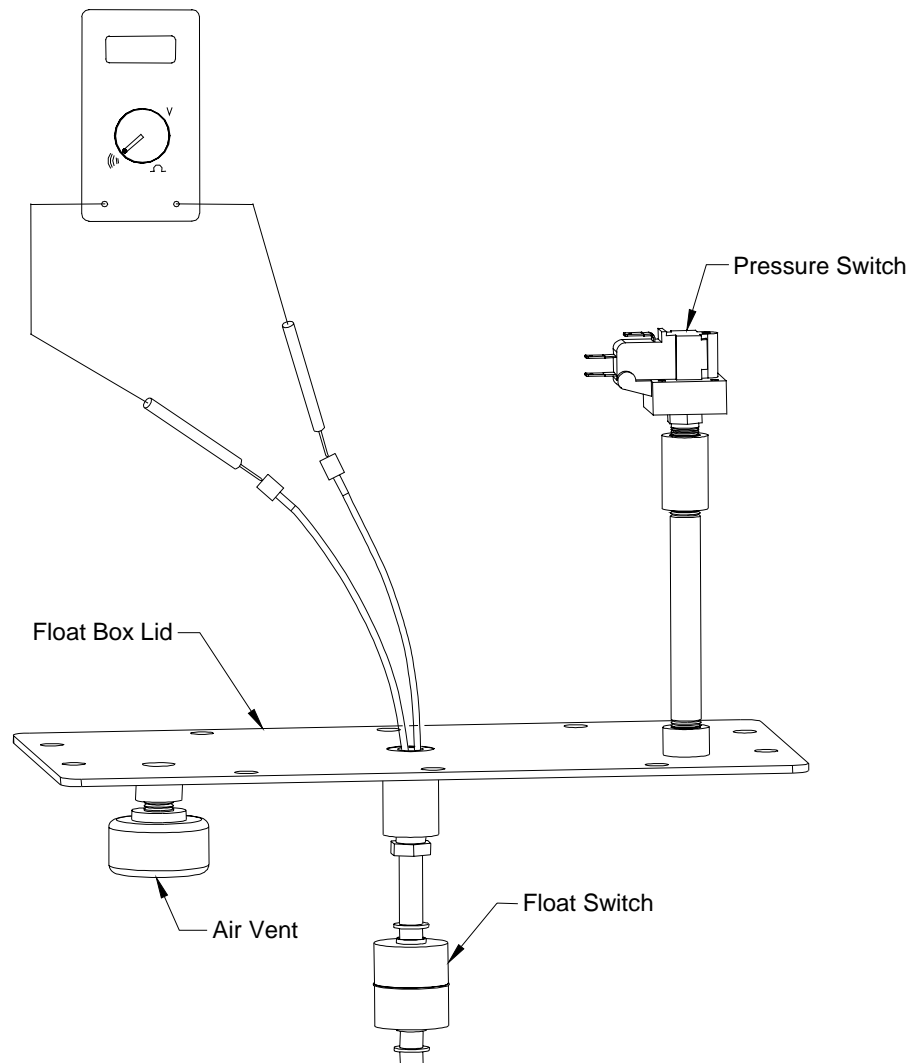

Figure 14

Float Switch Continuity Check



1. **DISCONNECT POWER AT CIRCUIT BREAKER.**
2. Remove rear cover from unit.
3. Disconnect float switch lead wires from wires B40 and B42.
4. Disconnect wires B73 and B74 from the pressure switch.
5. Remove lid from float box.
6. Make sure float travels freely along stem of float switch.
7. Place test leads in float switch terminals as shown.
8. Hold lid in same orientation as when installed.
9. Check continuity. There should be continuity. Replace as necessary.
10. Flip lid over.
11. Check for continuity. There should be no continuity. Replace as necessary.



Figure 15

Controller Check

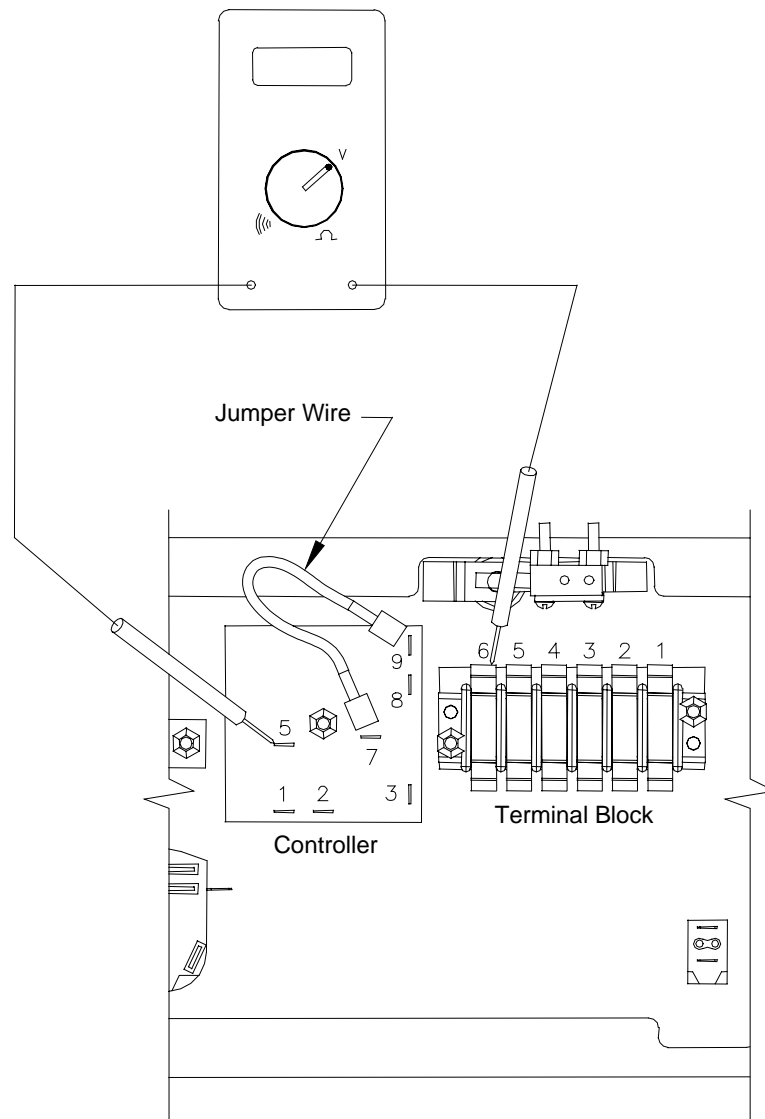

- 1. DISCONNECT POWER AT CIRCUIT BREAKER.**
2. Remove control panel, but leave plugged in.
3. Disconnect wires C98 and C99 from terminals 7 and 9 on the controller. Place a jumper wire between these two terminals.
4. Reconnect power. Turn unit on. **WAIT 9 MINUTES.**
5. Place test leads between terminal 5 of controller and terminal block position 6, as shown.
6. Use a spacer to hold door switch in closed position and simultaneously check voltage. Voltage should match serial plate voltage for 60 seconds, then drop.
7. If controller fails these tests, replace controller.

TROUBLESHOOTING

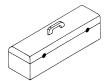
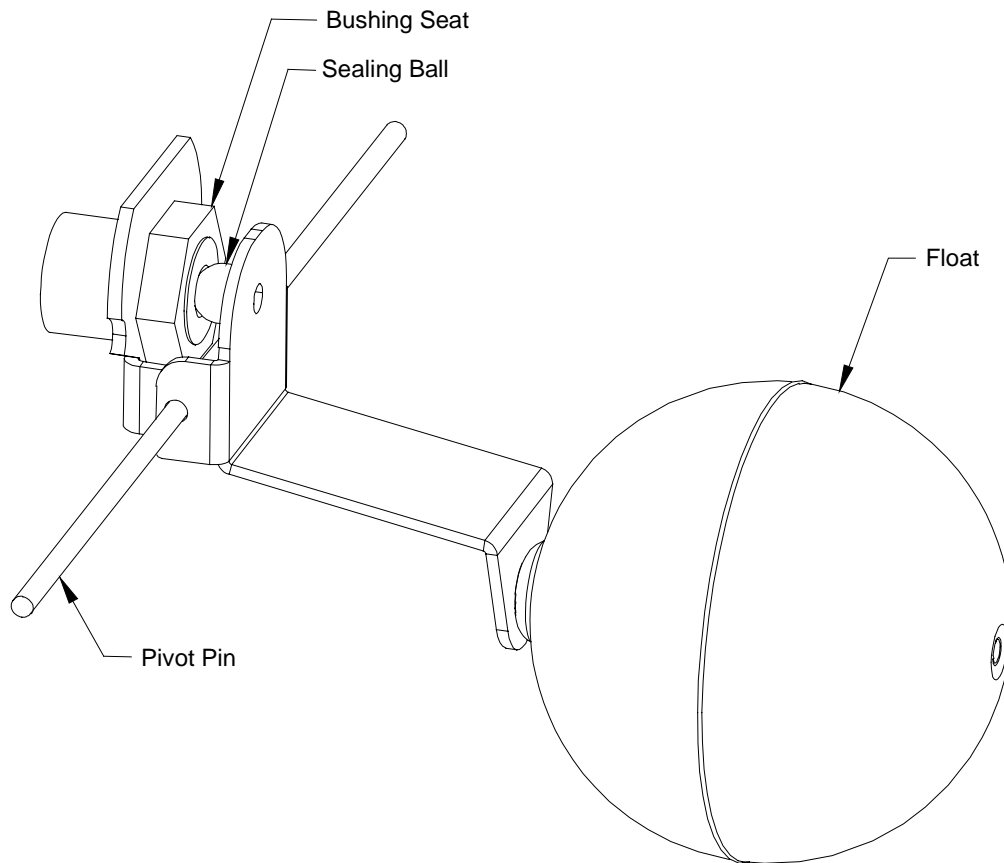

Figure 16

Inlet Float Valve Check



1. **DISCONNECT POWER AT CIRCUIT BREAKER.**
2. Remove rear cover.
3. Loosen water inlet compression fitting and rotate water inlet assembly out of the way.
4. Remove lid from float box.
5. Remove 1/8" pipe plug from the rear of the box on the left side (facing unit from rear).
6. Check inlet float valve mechanism (on left side facing unit from rear) for proper actuation.
7. Slide pin out of assembly through hole created by removal of the pipe plug.
8. Inspect sealing ball and bushing seat for debris and deposits.
9. Ensure that float has no leaks or deposits that would prevent it from floating properly.
10. Clean all parts in a container of descaling solution, or replace as necessary.
11. Reassemble all parts.

NOTICE

If the entire float valve assembly is replaced, new Teflon washers must be used and silicone must be used on the bushing seat threads and under the hex head.

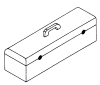
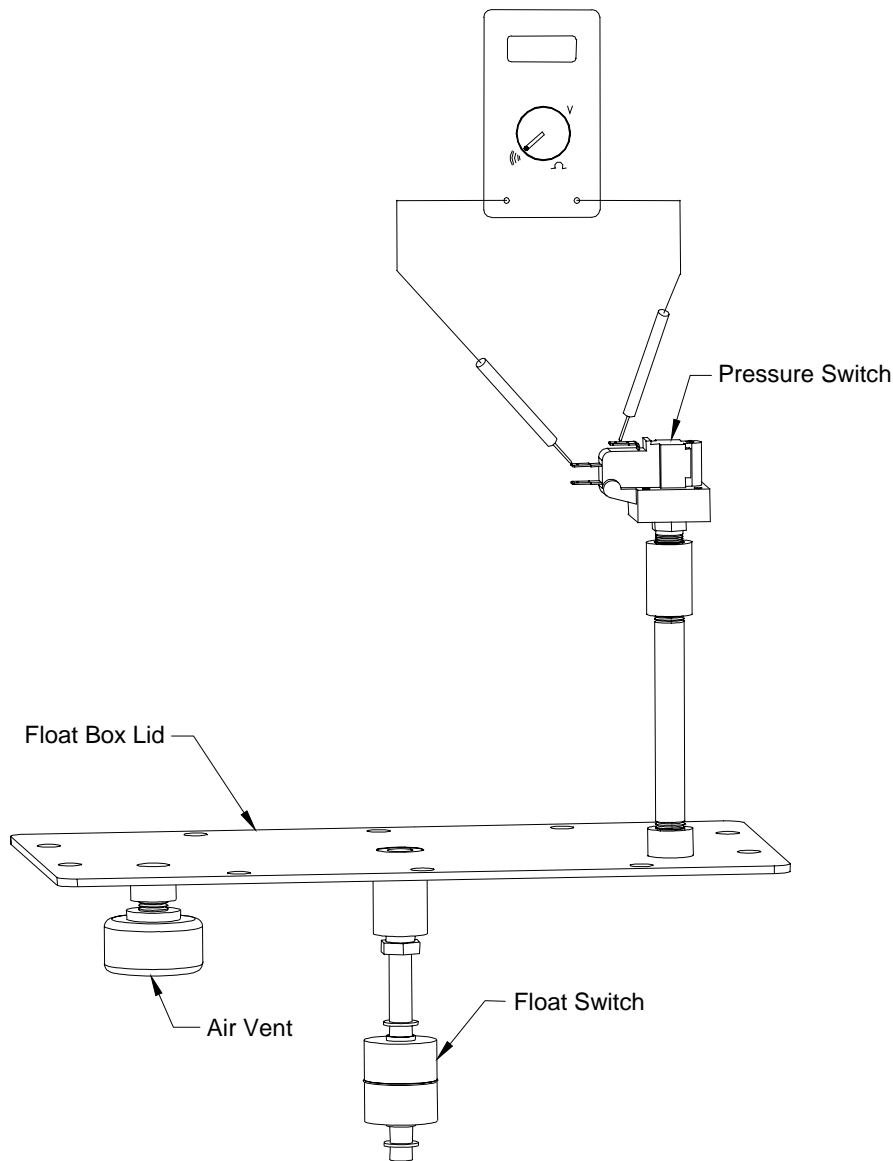

Figure 17

Pressure Switch Check

1. **DISCONNECT POWER AT CIRCUIT BREAKER.**
2. Remove rear cover.
3. Remove wires B73 and B74 from pressure switch "COM" and "NO" terminals.
4. Open door.
5. Place test leads on "COM" and "NO" terminals as shown.
6. Check continuity. There should NOT be continuity. Replace as necessary.
7. Remove pressure switch from lid.
8. With test leads on "COM" and "NO" terminals as before, gently blow into pressure port and check continuity. There SHOULD be continuity. Replace as necessary.

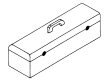
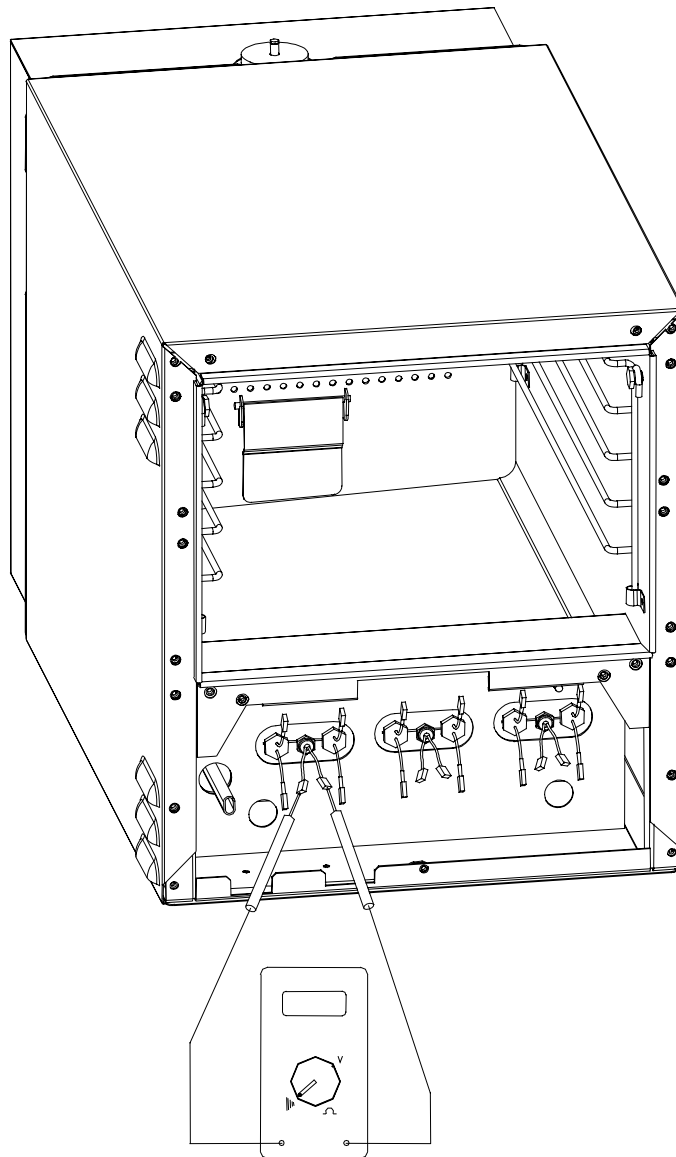

Figure 18

High-Limit Thermostats Check



1. Note: Allow cavity bottom to cool before performing this test.
2. Disconnect left thermostat lead wire from NO position of R1 relay.
3. Disconnect right thermostat lead wire from wire B58.
4. Disconnect remaining thermostat lead wires from each other.
5. Test each thermostat for continuity. Replace as necessary.
6. Reconnect all thermostat lead wires.

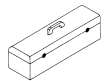
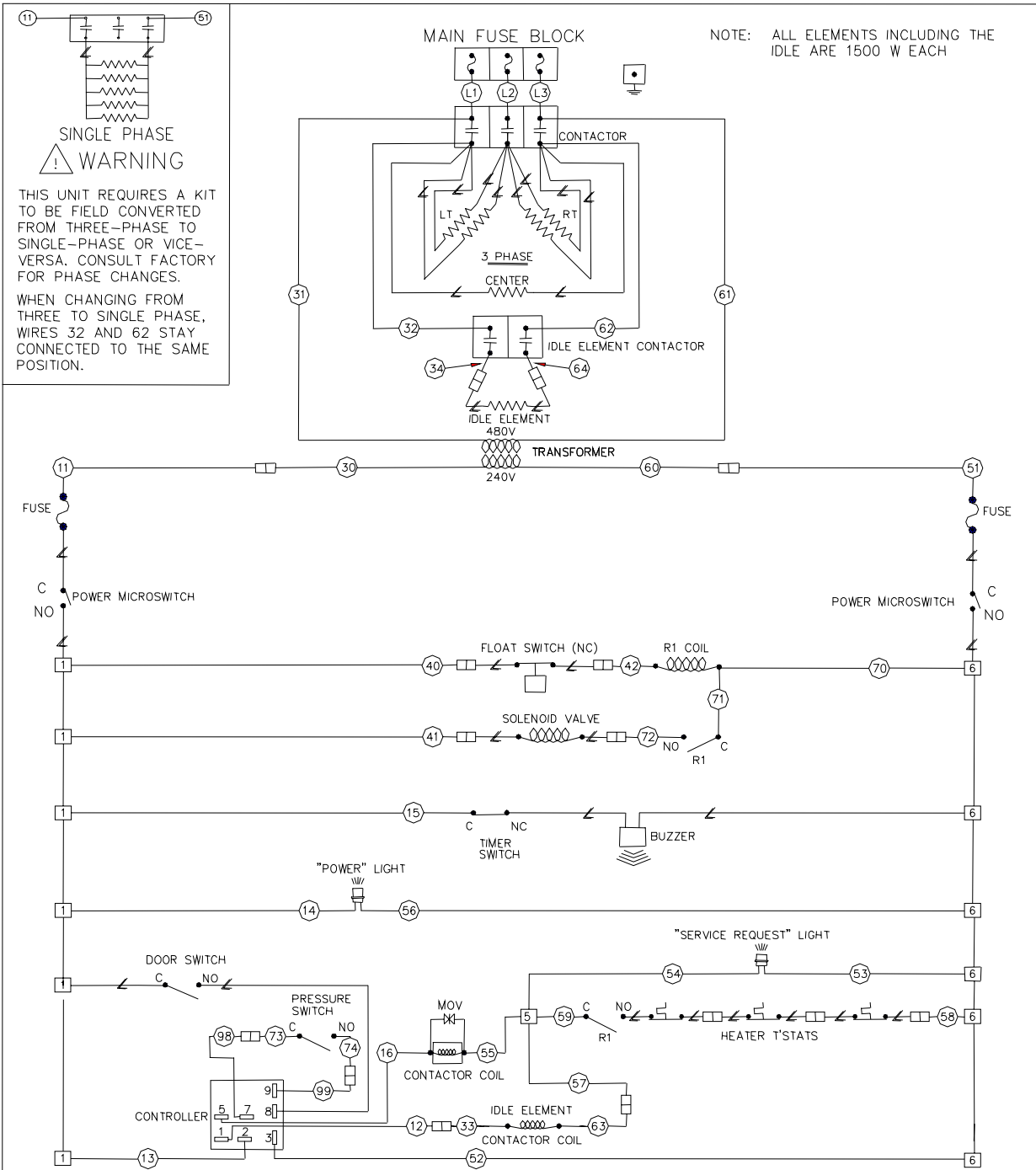

Figure 20

Electric Schematic for 480 Volt Model SEZ-3



SINGLE PHASE
WARNING

THIS UNIT REQUIRES A KIT TO BE FIELD CONVERTED FROM THREE-PHASE TO SINGLE-PHASE OR VICE-VERSA. CONSULT FACTORY FOR PHASE CHANGES.

WHEN CHANGING FROM THREE TO SINGLE PHASE, WIRES 32 AND 62 STAY CONNECTED TO THE SAME POSITION.

NOTE: ALL ELEMENTS INCLUDING THE IDLE ARE 1500 W EACH

- PLUG CONNECTION
- ∠ COMPONENT LEAD
- TERMINAL BLOCK CONNECTIONS
- WIRE NUMBERS

VOLTAGE	480	
PHASE	1	3
AMPERAGE	19	11



WIRING DIAGRAM
 480V
 SEZ-3

P/N
 1181576

TROUBLESHOOTING



Figure 21

Electric Schematic for 208, 220, and 240 Volt Model SEZ-5

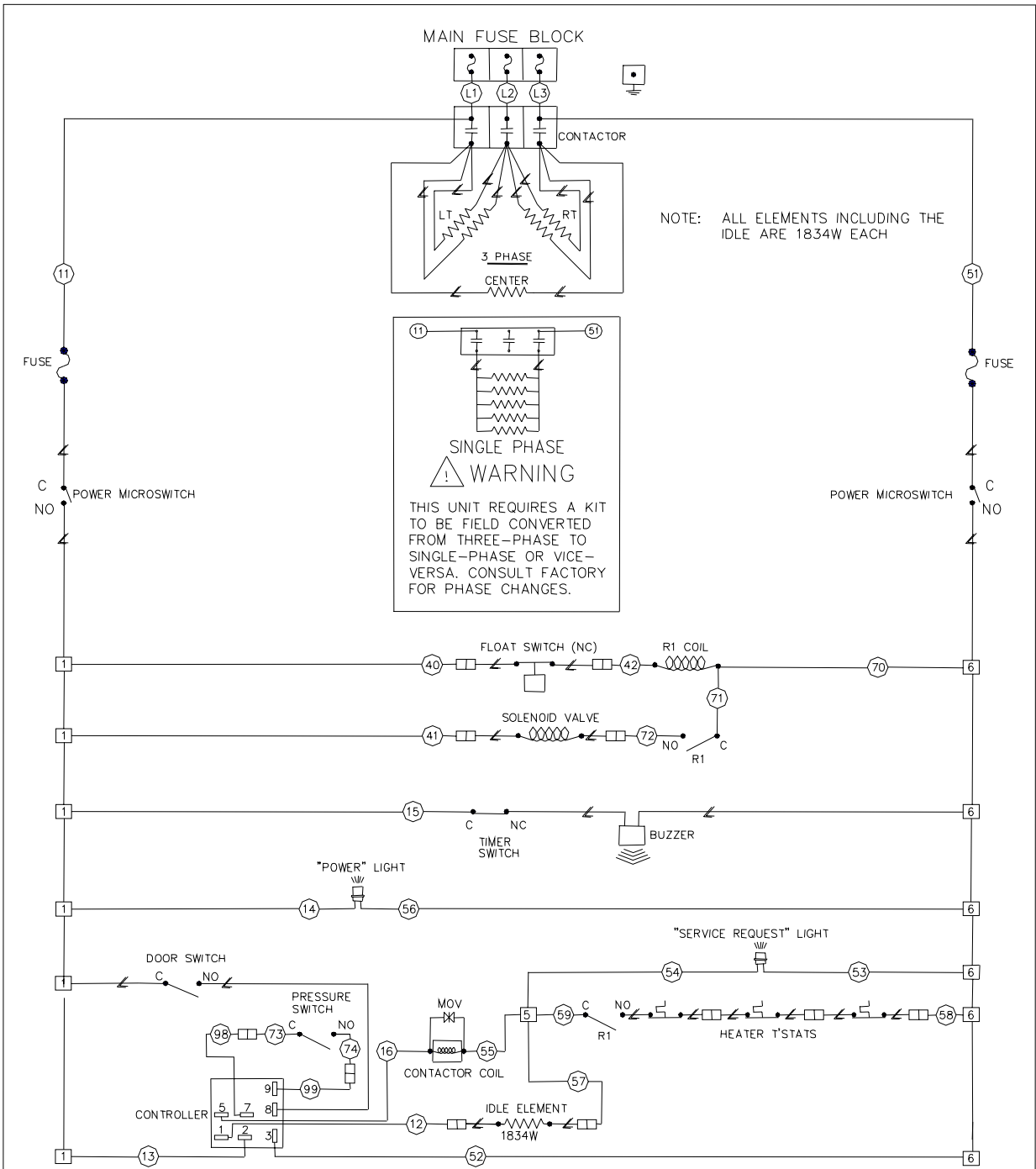

- ∟ COMPONENT LEAD
- TERMINAL BLOCK CONNECTIONS
- WIRE NUMBERS

VOLTAGE	208		240		220	
PHASE	1	3	1	3	1	3
AMPERAGE	57	33	49	29	54	31



WIRING DIAGRAM
208/220/240 V
SEZ-5

P/N
1181754

TROUBLESHOOTING

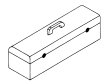
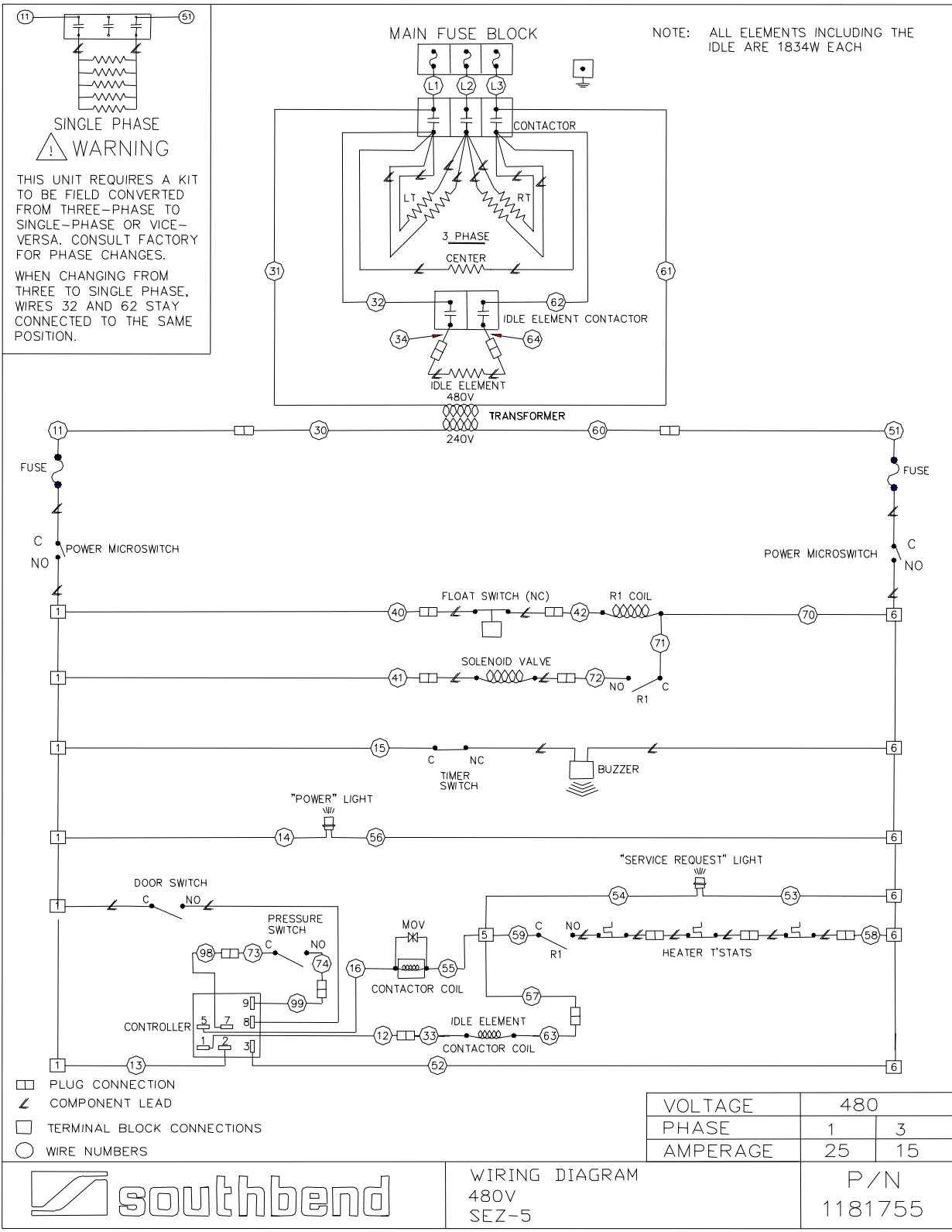
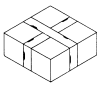

Figure 22

Electric Schematic for 480 Volt Model SEZ-5



TROUBLESHOOTING



PARTS

NOTICE

INSTALLATION OF OTHER THAN GENUINE SOUTHBEND PARTS WILL VOID THE WARRANTY ON THIS EQUIPMENT.

The serial plate with voltage, model, and serial information is located on the right side of the steamer cavity on the upper rear corner. On single units a second tag is located on the face of the door which will show only model and serial number. On tandem units, a second tag is on the right side of the right unit and the left side of the left unit.

Replacement parts may be ordered either through a Southbend Authorized Parts Distributor or a Southbend Authorized Service Agency.

When ordering parts, please supply the Model Number, Serial Number, Part Number, Description, Finish, and Electrical Characteristics as applicable.

For parts not listed, consult a Southbend Authorized Parts Distributor or Southbend Authorized Service Agency. Consult the Southbend Authorized Parts/Service Distributor list for the Authorized Parts supplier in your area. If this list is not available, call Southbend at 1-800-348-2558 to obtain this list.

Index of Parts Diagrams

Page Number	Description
41	Cavity and Heater Parts
42	Control Panel Parts (Rear View)
44	Control Panel Parts (Front and Isometric Views)
45	Water Inlet and Drain Parts
46	Door Assembly Parts
47	Float Tank Parts

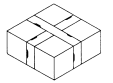

Cavity and Heater Parts

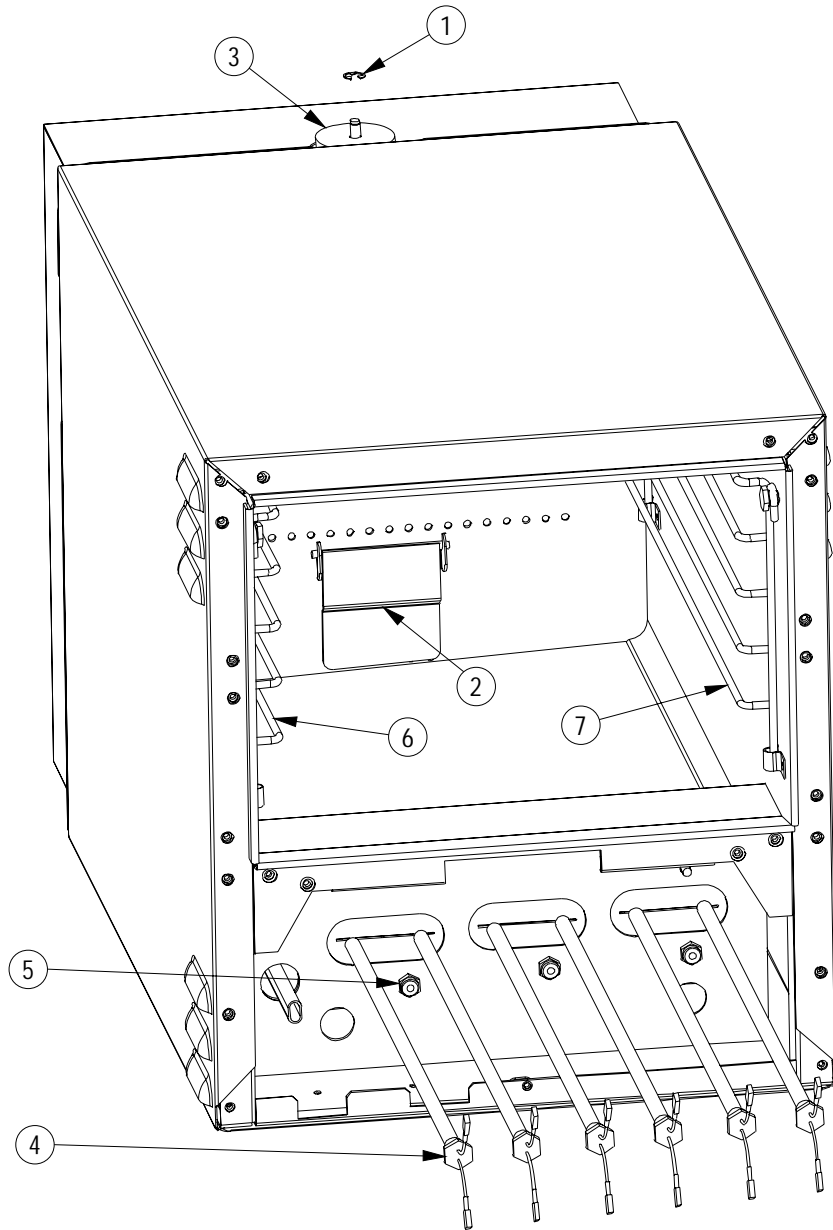

Key	Part Number		Qty	Description
	Model SEZ-3	Model SEZ-5		
1	1181601	1181601	1	Retaining Ring
2	1181544	1181544	1	Flap, backflow, weld assembly
3	1181522	1181522	1	Plate, cavity vent
4	1181508	1181771	6	Heater, cartridge, 208V (1500W for SEZ-3, 1834W for SEZ-5)
	1181509	1181772	6	Heater, cartridge, 220V (1500W for SEZ-3, 1834W for SEZ-5)
	1181510	1181773	6	Heater, cartridge, 240V (1500W for SEZ-3, 1834W for SEZ-5)
	1181511	1181774	6	Heater, cartridge, 480V (1500W for SEZ-3, 1834W for SEZ-5)
5	1181011	1181011	3	Thermostat, 200C, 600V
6	1178668	1178678	1	Side, rack, left
7	1178663	1178679	1	Side, rack, right

PARTS

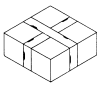

Control Panel Parts (Rear View)

See drawing on following page.

NOTE: The entire Control Panel Assembly can be ordered as part number [1181543](#).

Key	Part Number	Qty	Description
1	6600430	6	Locknut
2	1181533	1	Controller
3	1181524	1	Bracket, on/off switch
4	1178642	1	Gasket, control
5	1178549	1	Screw, set
6	1178535	1	Switch, power
7	1178391	1	Fuse block, controls
8	1178341	1	Timer, with mounting screw
9	1178330	1	Light, indicating, red clip lens
10	1178329	1	Light, indicating, amber clip lens
11	1178276	1	Cam actuator, steamer
12	1177865	1	Nut, 5/8-18
13	1177396	6	Locknut, 6-32 ss
14	1175712	1	Buzzer assembly
15	1170336	1	Marker strip
16	1170335	1	Block, terminal
17	1146398	2	Screw, 6-32x3/8, ss, phil pan hd
18	1146320	4	Screw, 6-32x1

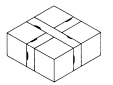

Control Panel Parts (Rear View)

See parts list on previous page.

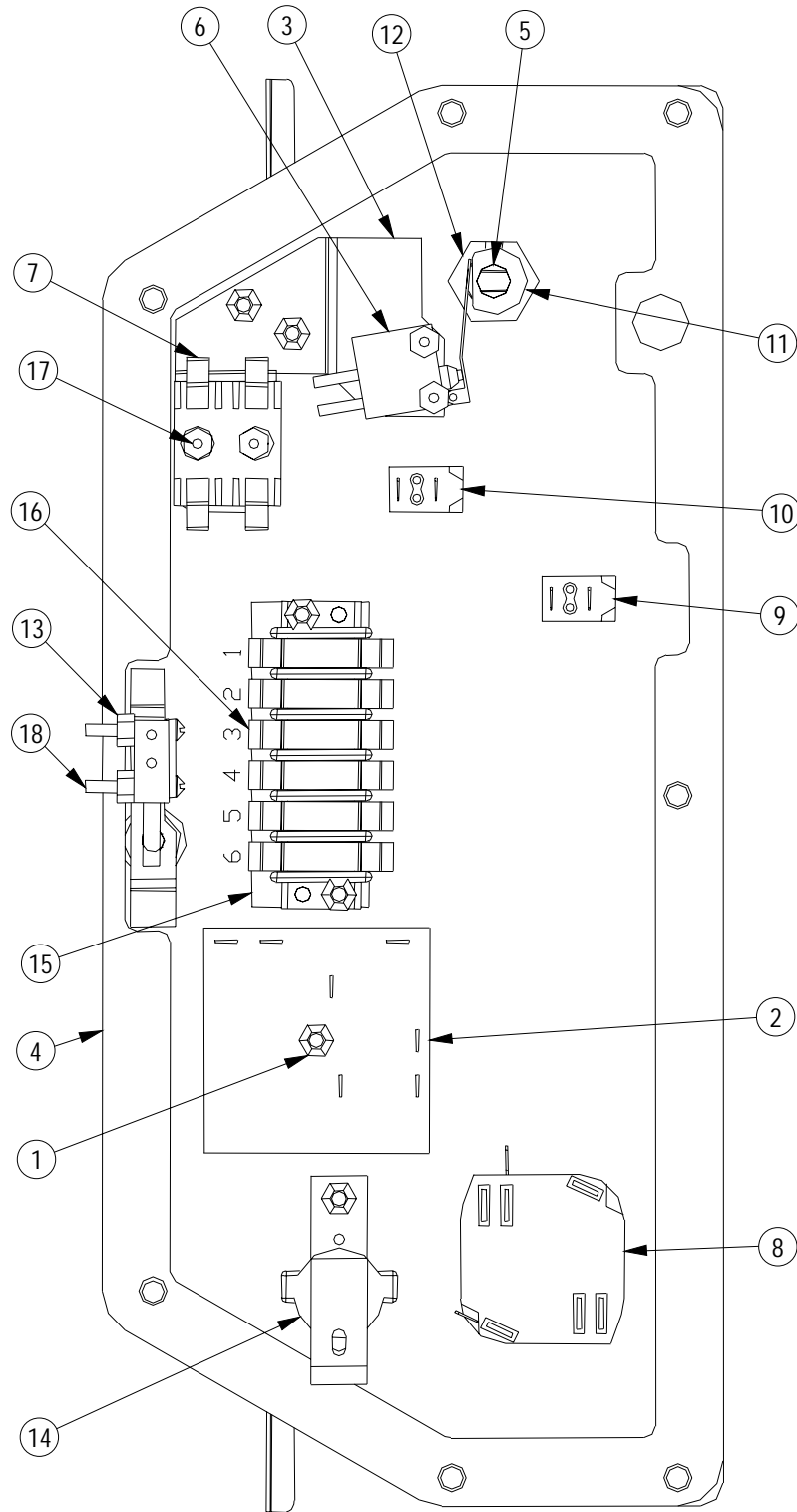

PARTS

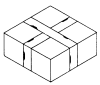

Control Panel Parts (Front and Isometric Views)

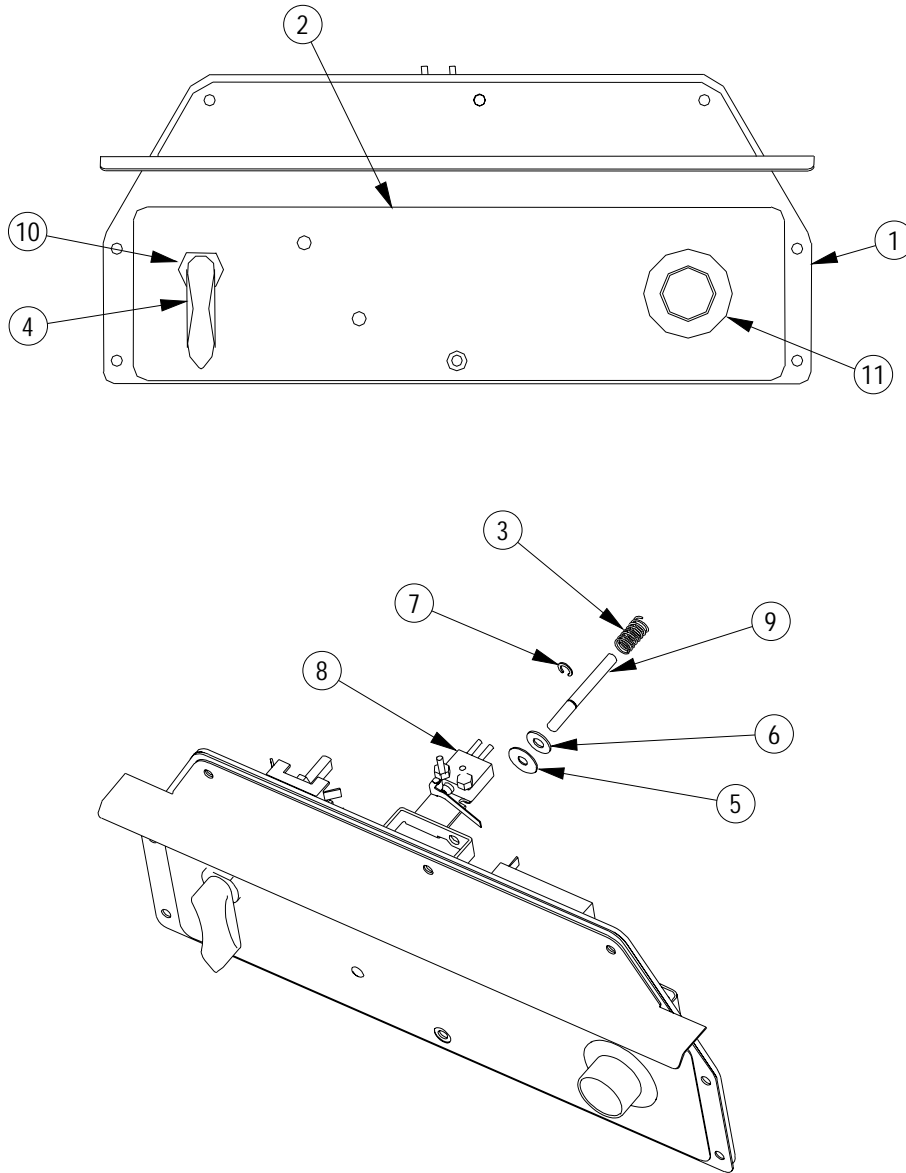

NOTE: The entire Control Panel Assembly can be ordered as part number [1181543](#).

Key	Part Number	Qty	Description
1	1181529	1	Panel, control, weld assembly
2	1181513	1	Polypanel with timer
3	1179932	1	Spring, retaining
4	1178388	1	Valve lever weld assembly
5	1178347	2	Seal, shaft
6	1178339	1	Washer
7	1178338	1	Retaining ring
8	1178331	1	Switch, door
9	1178270	1	Switch, actuator rod
10	1177770	1	Valve lever bushing
11	1170337	1	Knob

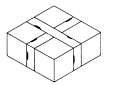

Water Inlet and Drain Parts

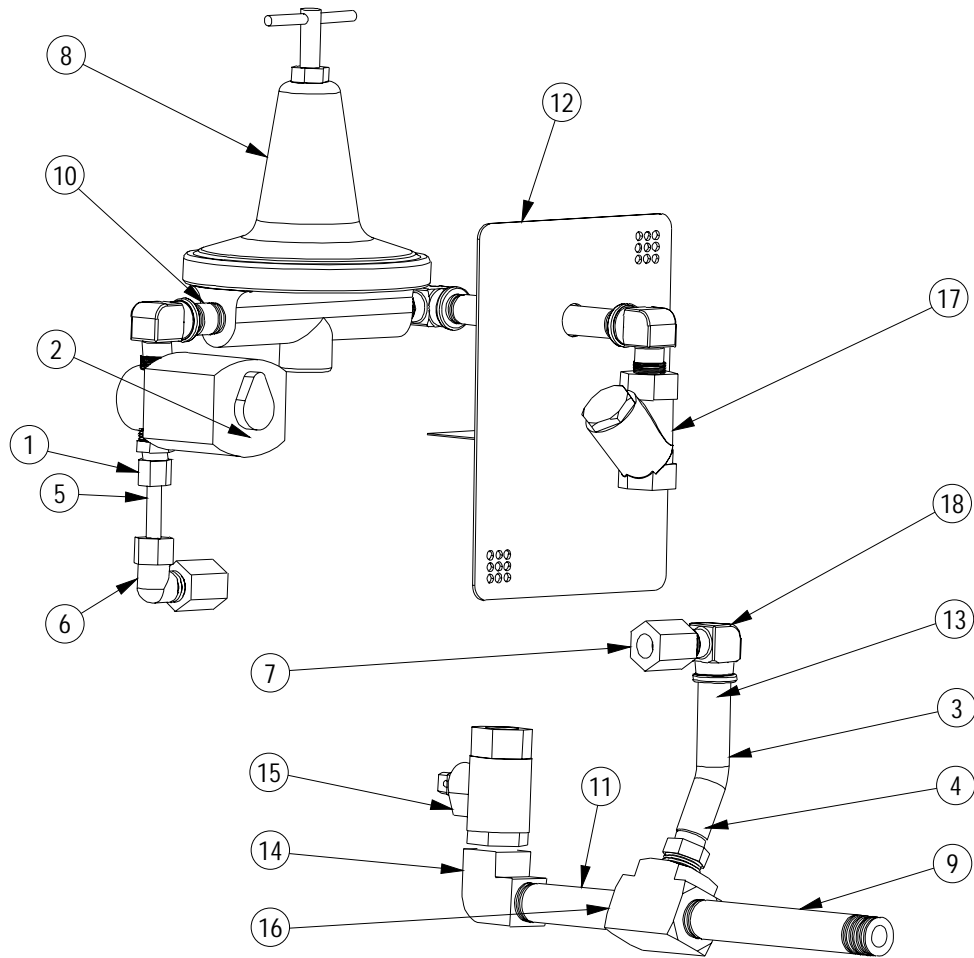

Key	Part Number	Qty	Description
1	PP-285	1	Fitting, 1/4 NPT male
2	1181607	1	Valve, solenoid
3	1181591	1	Hose, 1/2 I.D.
4	1181590	1	Fitting, 3/8 MPT x
5	1181589	1	Tube, water inlet
6	1181579	1	Elbow 1/4CC X
7	1181578	2	Coupling, 1/2-UNC X
8	1181563	1	Regulator, water
9	1181562	1	Nipple, 3/8" NPT, X
10	1181559	1	Nipple, 1/4-NPT
11	1181557	1	Nipple, 3/8 NPT
12	1181556	1	Water inlet weld assembly
13	1181551	1	Nipple, close
14	1181528	1	Elbow, 3/8 NPT
15	1181526	1	Valve 3/8 drain
16	1180956	1	Tee, 3/8 brass
17	1173428	1	Strainer, Y in-line
18	1161048	4	Elbow, 1/4

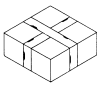

Door Assembly Parts

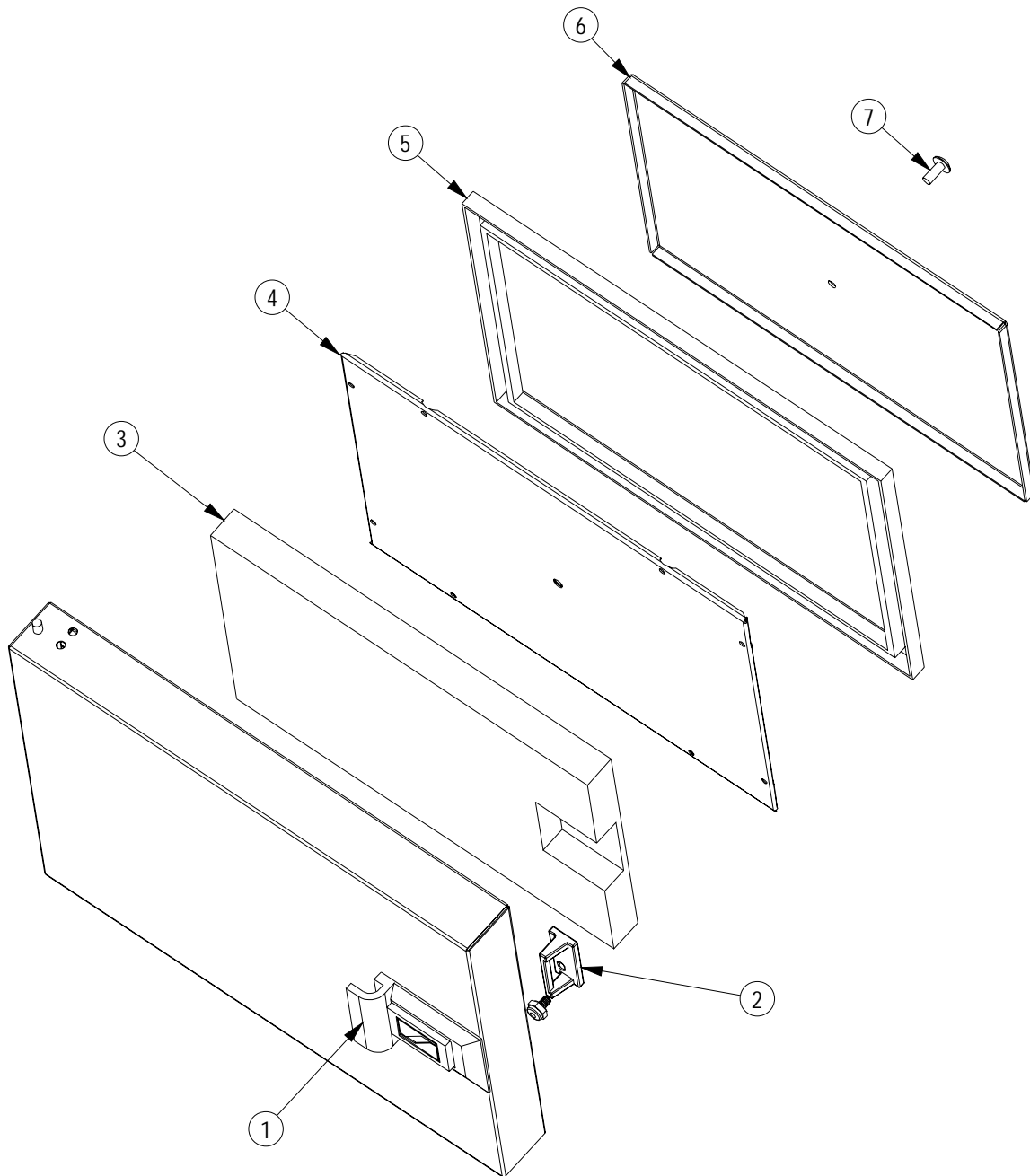

Key	Part Number		Qty	Description
	Model SEZ-3	Model SEZ-5		
1	1177317	1177317	1	Latch assembly
2	1177080	1177080	1	Cast striker
3	1178171	1181018	1	Door insulation block
4	1178105	1181016	1	Panel assembly, inner door
5	1178096	1181010	1	Gasket, door
6	1178106	1181001	1	Gasket rtrn pnl
7	1173224	1173224	1	Screw, 1/2-20 x 5/8 s, slot trs
1-7	1178167	1181015	1	Complete door assembly

PARTS

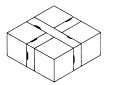

Float Tank Parts

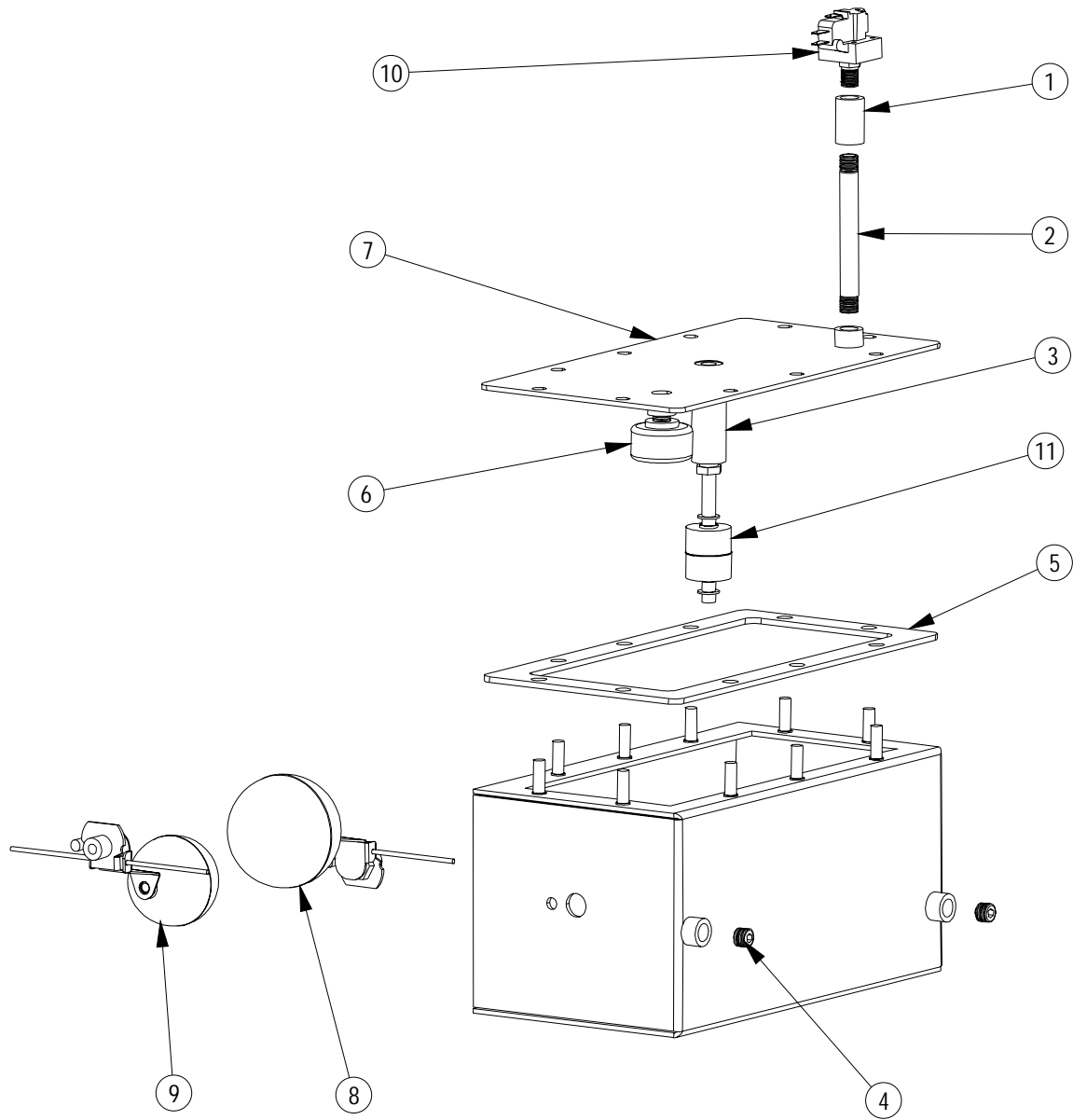

Key	Part Number	Qty	Description
1	PP-501	1	Coupling, 1/8 npt ss
2	1181775	1	Nipple, 1/8 npt x 3.5, brass
3	1181617	1	Float support
4	1181597	2	Plug, pipe, brass
5	1181565	1	Gasket, float tank lid
6	1181561	1	Vent, air
7	1181560	1	Top, float tank
8	1181541	1	Float valve assembly, inlet
9	1181542	1	Float valve assembly, outlet
10	1181540	1	Pressure switch
11	1178340	1	Switch, float, subassembly

SUPER SIMPLE STEAM SEZ SERIES COUNTERTOP STEAMERS

A product with the Southbend name incorporates the best in durability and low maintenance. We all recognize, however, that replacement parts and occasional professional service may be necessary to extend the useful life of this unit. When service is needed, contact a Southbend Authorized Service Agency, or your dealer. To avoid confusion, always refer to the model number, serial number, and type of your unit.



C



SOUTHBEND
REGISTERED TO ISO 9001
CERTIFICATE NO. A2062



Certification No. FM25780



Southbend Registered to ISO 9001

Southbend
1100 Old Honeycutt Road, Fuquay-Varina, NC 27526
(800) 348-2558 or (919) 552-9161 • FAX (800) 348-2558 or (919) 552-9798