



YOU CAN TRUST



YOU CAN TRUST

INSTRUCTIONS MANUAL



Skyfood Equipament LLC

OFFICE

175 SW 7th Street - Suite # 2416
Miami, FL 33130

1-800-503-7534 | 305-868-1603

UG0069 - ENGLISH

Data de Correção: 03/07/2023



12" AUTOMATIC SLICER 1/2 HP ETL/NSF - SKYFOOD

1212E

- BESIDES THIS EQUIPMENT, A COMPLETE RANGE OF OTHER PRODUCTS ARE MANUFACTURED, CONSULT OUR DEALERS
- DUE TO THE CONSTANT IMPROVEMENTS INTRODUCED TO OUR EQUIPMENTS, THE INFORMATION CONTAINED IN THE PRESENT
INSTRUCTION MANUAL MAY BE MODIFIED WITHOUT PREVIOUS NOTICE.

www.skyfood.us

INDEX

- 1. Introduction 3**
- 1.1 Safety 3
- 1.2 Main Components 5
- 1.3 Technical Characteristics 5
- 2. Pre Operation 6**
- 3. Operation 6**
- 3.1 Cutting..... 6
- 3.2 Grinding..... 6
- 4. General Safety Practices 7**
- 4.1 Basic Operation Procedures 7
- 4.2 Safety Procedures and Notes before Switching the Machine ON 8
- 4.3 Routine Inspection..... 8
- 4.4 Operation 9
- 4.5 After Finishing The Work..... 9
- 4.6 Maintenance 9
- 4.7 Warning..... 9
- 5. Analysis and Problem Solving 10**
- 5.1 Problems, Causes and Solutions.....10
- 6. Maintenance 11**
- 7. Electric Diagram..... 15**

7. Electric Diagram

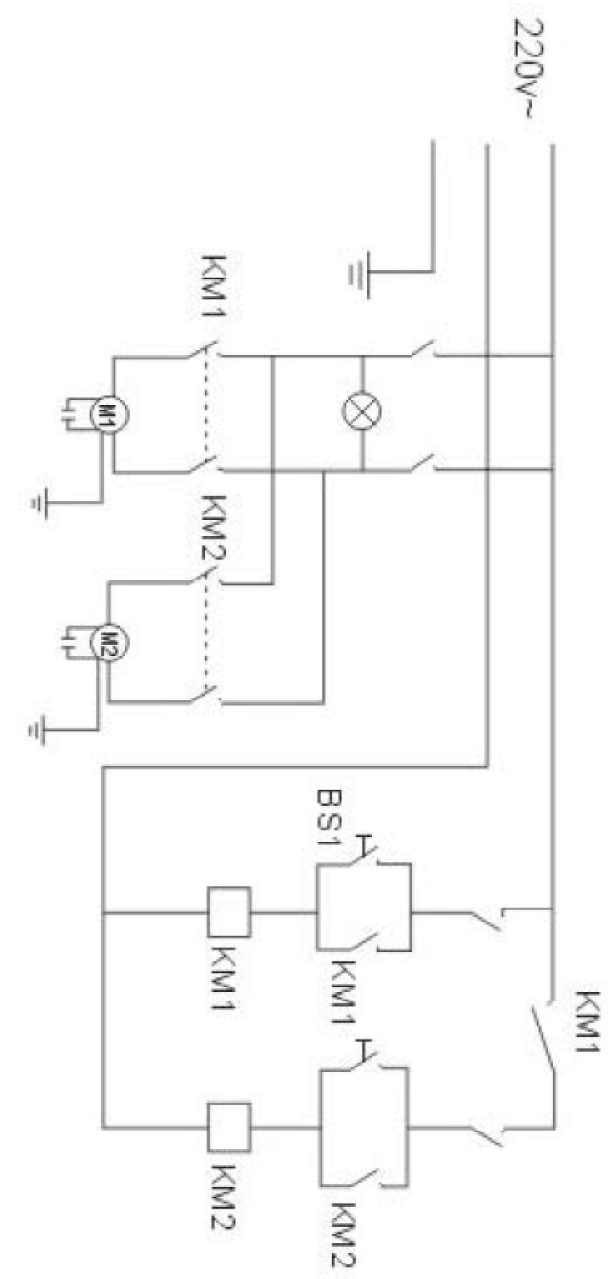

Warranty Registration



Questions about how to complete this form?
Call 1-800-503-7534 / 305-868-1603
Return completed form to:
SKYFOOD EQUIPMENT LLC
11900 Biscayne Blvd, Suite 616
North Miami, FL 33181 - USA
Or fax form to:
786 522 6765

User Details

Contact Person: _____

Business type:

- Bakery and Baked Operations
Bakery (Associated with Restaurant)
Baking Center
Business and Industry In-House Feeding
Butcher
Catering
Club Stores
Convenience Store
Country Club
Deli/Caterers (Chain / Restaurant)
Deli/Caterers (Independent and Non-Restaurant)
Food Store
Government
Hospital
Lodging
Misc Merchandiser with Grocery
Misc Merchandiser with NO Grocery
Meat Packer and Purveyor
Other Business that prepares or serves food
Other Business that sells but doesn't serve food
Pizzeria (Drive In / Carry-Out)
Restaurants (Independent / Chain)
School
Steakhouse / Cafeteria
Supermarket / Grocery
Theme Park
University / College
Winery / Winery
Warehouse Clubs
Wholesale Baking Operations (Non-Institutional)

Company Name: _____

Address: _____

City: _____

State: _____

Zip Code: _____

Phone: _____

Fax: _____

E-mail: _____

Web page: _____

I would like to join the Mail List

I would like to join the E-mail List

Product Details

Product Commercial Item: _____

The Product Commercial Item can be found on the machine's Product Identification Label

Serial Number: _____

Confirm Serial Number: _____

For information, the Product Identification Label can also be found on the machine's Product Identification Label

Proof of Purchase: Yes No

Purchased On: _____ (mm / dd / yyyy)

Purchased From: _____

Company Name: _____

* Indicates required field.

** Indicates required field, not mandatory by Fax.

1. Introduction

1.1 Safety

When incorrectly used this equipment is a potentially DANGEROUS machine. Maintenance, cleaning or any other service shall be performed by a duly trained person and with the machine unplugged .

To avoid accidents respect the following instructions:

1.1.1 Read all the instructions.

1.1.2 In order to avoid the risk of electric shocks and damage to the machine, never operate it wearing wet clothes or shoes, install the equipment on a wet or humid surface nor dip it in water or any other liquid, and do not spray water directly on it.

1.1.3 The use of the equipment must always be supervised, specially when used next to children.

1.1.4 Before cleaning and when not in use or before inserting or removing accessories, maintenance, or other services, disconnect machine from power source.

1.1.5 - Do not leave the electric cable on the edge of the table or counter nor let it touch hot surfaces.

1.1.6 Do not use the equipment if it is not working correctly, nor if it has been damaged in any way. In case that happens, take the equipment to the nearest Technical Assistance to check it up.

1.1.7 The use of accessories not recommended by the manufacturer may cause personal injuries.

1.1.8 Keep your hands or any tool out of the machine while operating to avoid personal injuries or any damage to the equipment.

1.1.9 Make sure the equipment voltage and the network voltage are the same, and the equipment has been solidly grounded.

IMPORTANT

Make sure the cord is in perfect conditions for use. If it is not, change it for a new one in accordance with the technical specifications and safety rules.

The substitution shall be made by a qualified professional , and shall respect the local safety norms.

IMPORTANT

This equipment must not be used by children or any persons with reduced physical or mental aptness, lack of experience or knowledge, unless they are under supervision or have received from the person responsible for safety, proper instructions on how to use the equipment.

IMPORTANT

Children shall be watched in order to avoid them to play with the equipment.

IMPORTANT

In case of emergency take off the plug from its socket.

IMPORTANT

Never spray water directly on to the equipment.

c) Redirecting a customer searching for a SKYFOOD product to a product other than a SKYFOOD product.

d) Indicating or implying that a price that is below the IMAP price can be obtained at the online cart or checkout stage (e.g. "See price in cart", "Email for better price", "Click here for lower price", "Log in for price", "Add to cart for lower price", "Chat for price").

IMAP does not establish maximum advertised prices. All internet dealers and reseller websites may offer SKYFOOD products at any price in excess of the IMAP.

At the sole discretion of Skyfood, failure to comply with IMAP, intentional and/or repeated failure to abide, it reserves the right to put internet dealers and reseller websites account on hold, until prices are adjusted.

SKYFOOD can terminate or amend any part or all of this policy at any time without prior notice.

Return Policy

All returns are subject to the prior authorization of SKYFOOD, in its discretion. Buyer must contact Buyer Support at **305-868-1603**, or by fax at **305-866-2704**, or via e-mail at **support@skyfood.us** in order to request a Return Authorization number ("RA") providing, along with the identification of the goods, a specific reason for return. Buyer Support will either authorize or deny the request for return. Only NEW and UNUSED items are acceptable for return. Unauthorized returns will be destroyed and no credit issued. All authorized returned goods must be shipped freight prepaid to SKYFOOD.

All returned goods are subject to a 20% handling/restocking fee. All returns must be returned in their original packaging and within thirty (30) days from the shipping date.

SKYFOOD reserves the right to change the terms and conditions of this Commercial Policy at any time without any prior notice. It also reserves the right to change the design and specifications of its equipment or any related documentation at any time. The end user is not entitled to upgrades or refunds resulting from these changes.

These Terms and Conditions were last updated on May 26th, 2022.

SKYFOOD EQUIPMENT LLC - SERVICE

Unless otherwise specified, new SKYFOOD products, excluding accessories, sold by SKYFOOD EQUIPMENT, LLC. ("SKYFOOD"), for use only in the continental United States (collectively, "Products" or singularly, "Product"), are warranted to be free from defects in materials and workmanship for a period of one (1) year from the date of purchase by the original purchaser/user ("End User"), or eighteen (18) months from the date of shipment from SKYFOOD's warehouse, whichever expires first. Several new products and accessories may be warranted for a period other than one (1) year while others may be subject to travel limitations, as specified on the products Instruction Manual. **Proof of purchase must be presented; if not this warranty will be VOID.** No warranty is given or implied to a subsequent transferee or any other third party. This warranty is expressly conditional upon SKYFOOD being notified of any defects in materials or workmanship within five (5) days of its occurrence, within the warranted time period. If a notice of a claim under this warranty is timely made by the End User, SKYFOOD or a SKYFOOD's designated service company ("Service Company"), will repair or replace the Product, at SKYFOOD's discretion, subject to the additional conditions hereinafter described.

This warranty shall not apply if damage occurs from improper installation or maintenance performed by an unauthorized service company ("Service Company"), wrong voltage, nor to the extent that Products or parts have been used other than in conformance with operating and maintenance instructions, subjected to misuse or abuse or damaged by accident, acts of God, abnormal use, stress or any other matter unrelated to SKYFOOD, and beyond its reasonable control. **This warranty does NOT cover service labor and travel to perform adjustments on products and/or accessories.** In addition to wear and tear of certain items, such as, but not limited to; glass parts, blades, stones, chopper cutting knives, plates, slicing knives, cutting disc, gaskets, oil changes, sealing tape, heat seal wires, worm gears, self-lubricating bushings, carbon brushes for electric motors, and other parts expendable by nature and that need to be replaced frequently. **Electrical components are subject to natural wear and tear, and are NOT covered by this warranty. THIS WARRANTY EXCLUDES ALL ORAL, STATUTORY, EXPRESS OR IMPLIED WARRANTIES WHICH MAY BE APPLICABLE TO SKYFOOD, INCLUDING, BUT NOT LIMITED TO, ANY IMPLIED WARRANTY OF MERCHANTABILITY AND FITNESS FOR PARTICULAR PURPOSE.** Under no circumstances shall SKYFOOD be liable for loss of use, revenue or profit or for incidental or consequential damages. SKYFOOD shall under no circumstances be liable for any loss, damage, concealed damage, expense or delay of goods for any reason when said goods are in the custody, possession or control of third parties selected by SKYFOOD to forward, enter, clear, transport, or render other services with respect to such goods. The sole and exclusive remedy for breach of any warranty is limited to the remedies provided in the paragraph above.

All products held at non-commercial facilities or domiciles, must be taken or shipped, shipping charges prepaid, either to SKYFOOD's facility or a SKYFOOD's designated service company ("Service Company"). Products held at commercial facilities and weighing less than seventy (70) lbs. must be taken or shipped, shipping charges are prepaid, either to SKYFOOD's facility or to a Service Company. Mileage or travel time will NOT be paid. SKYFOOD offers a limited on-site warranty for products ONLY held at commercial facilities, whose net weight exceeds seventy (70) lbs., provided they are installed in a location that is within a thirty (30) mile radius of a Service Company. **End Users are responsible for all extra travel and mileage rates.** In this case, warranty services will be provided during regular business hours.

Accessories will be replaced or repaired under warranty, for a period of (30) days, beginning from the date of purchase by the original purchaser/user ("End User"), or eighteen (18) months from the date of shipment from SKYFOOD's warehouse, whichever expires first.

This warranty shall not take effect until a properly completed and executed **WARRANTY REGISTRATION** form has been received by SKYFOOD EQUIPMENT, LLC, within thirty (30) days from the date of purchase. The **WARRANTY REGISTRATION** is available either in the Instruction Manual of every Product or at SKYFOOD's website www.skyfood.us. The End User must fill out the **WARRANTY REGISTRATION** form and send it to SKYFOOD according to the instructions posted on the referred website. **Failure to do so will VOID the warranty.**

No extended warranties for third party products. There are no other express warranties or conditions other than the one offered by each manufacturer for products sold by SKYFOOD, not under the SKYFOOD brand.

For questions or assistance, do not return the product or accessories to the store, please call Toll Free 1-800-503-7534, or visit the Customer Service section at www.skyfood.us. For faster service please have the items name, serial number, and proof of purchase for the operator to assist you.

SKYFOOD reserves the right to change the terms of its limited warranty at any time without any prior notice. It also reserves the right to change the design and specifications of its equipment or any related documentation at any time. The end user is not entitled to upgrades or refunds resulting from these changes.

Updates

These Terms and Conditions were last updated on May 2nd, 2016.

For questions or assistance, call SKYFOOD EQUIPMENT Toll Free: **1-800-503-7534**, or visit the Customer Service section at **www.skyfood.us**.

TERMS AND CONDITIONS OF SALE

Terms of Sale

Purchase of any products sold by SKYFOOD shall be subject to and expressly limited by the terms and conditions contained herein. No changes to, waiver of, or addition to any of these terms and conditions shall be effective unless agreed to in writing and signed by SKYFOOD. Buyer acknowledges and agrees that these terms and conditions supersede the terms and conditions of any purchase order or other documentation used by Buyer and, except for delivery and billing addresses, and quantities prices and items ordered, any conflicting or additional terms are void and have no effect, but that Buyer may place orders by use of purchase orders and other documentation for its convenience purposes only. Notwithstanding the foregoing, SKYFOOD reserves the right at any time to amend these terms and conditions, and Buyer shall be deemed to accept such amended terms and conditions by ordering products herein offered after the date of such amendment. Additional special terms and conditions of SKYFOOD may be applicable with respect to certain products.

Orders Acceptance

All orders from Buyers, whether solicited and written by either a SKYFOOD EQUIPMENT, LLC (“SKYFOOD”) Sales Representative, distributor or dealer, are deemed offerings to purchase until accepted by SKYFOOD. SKYFOOD reserves the right to accept orders in full or in part. Acceptance may be either by written confirmation or shipment of the order, in full or in part.

Shipping

TERMS – All prices are FCA (Free Carrier) shipping point. Unless express instructions in writing are received from the Buyer, SKYFOOD has complete freedom in choosing the means, route and procedure to be followed in the handling, transportation and delivery of the goods. SKYFOOD will advance the shipping costs on behalf of the Buyer and charge it accordingly. **SKYFOOD shall under no circumstances be liable for any loss, damage, concealed damage, expense or delay of goods for any reason whatsoever when said goods are in the custody, possession or control of third parties selected by SKYFOOD to forward, enter, clear, transport, or render other services with respect to such goods. Please, inspect your unit upon arrival at the destination and report any transit damage to SKYFOOD and to the shipping company, in order to initiate a claim with the latter. Claims must be reported to the transportation company within fifteen (15) days as of the date of the shipping.**

Free Shipping

Orders of \$3,500.00 or more, with a minimum of 2 pieces (mixed or matched), shipped to the same address in the continental United States will have free shipping.

Rush Order

Rush order, when available and shipped to the same address in the continental United States, is subject to a “Rush Order Fee”, in the amount of \$30.00. Please check lead times prior to ordering. If the due date is not met, the “Rush Fee” will be refunded.

Tax Information

Any tax, duty, custom or other fee of any nature imposed upon the products, their sale, transportation, delivery, use or consumption shall be paid by Buyer in addition to the price quoted or invoiced. If SKYFOOD is required to prepay any such tax or fee, Buyer will reimburse SKYFOOD. Buyer must provide SKYFOOD with a resale/exemption certificate in order to avoid the withholding of applicable taxes.

Interest

Past due balances are subject to a interest charge of 1.5% per month or the highest rate permitted by law, whichever is lower, until paid.

Internet Minimum Advertised Pricing - IMAP

Our IMAP pricing policy is intended for consumers to purchase from internet dealers and reseller websites based on loyalty and customer care expectations. This policy is effective as of the effective date stated below, and supersedes all previous Minimum Advertised Pricing – MAP policies related to SKYFOOD products as of that date. This IMAP policy shall work under the following guidelines:

Products:

The Internet Minimum Advertised Price for all SKYFOOD products can be found on our current Price List.

This IMAP applies only to the advertising and sales of SKYFOOD products which are sold to U.S. customers in the United States via the internet.

This IMAP policy is not applicable to: 1) Any physical store location, 2) Any email newsletters sent to your customer database, 3) In print publications or on any other media.

Procedures:

You can choose to advertise and sell, at any price, any SKYFOOD product on the internet. SKYFOOD will not control advertising and selling prices on the internet.

- Advertising and/or Selling below IMAP Price:

It shall be a violation to this policy to advertise and sell or offer for sale a SKYFOOD product on the internet at a sales price below the internet minimum advertise price (“the IMAP”). Repeatedly re-pricing due to IMAP prices breaches by other internet dealers and reseller websites is not an acceptable justification for violation of this policy.

Sales Price shall not include the cost of shipping or tax. In order to avoid any doubt, customers may offer free shipping to end users, without impacting this policy.

SKYFOOD reserves the right to suspend the enforcement of this policy for certain products, as and when SKYFOOD in its sole discretion, deems appropriate (e.g. product closeouts, specials, etc.).

- Prohibited Advertising Methods:

SKYFOOD has written this policy in an effort to protect and communicate the expectations for the internet dealers and reseller websites. Therefore, SKYFOOD considers any of the following to be damaging to our brand and thus are not permitted by internet dealers and reseller websites that use our brand for advertising:

- a) Advertising SKYFOOD products on third party internet dealers and reseller websites at a price that is below the IMAP Price.
- b) Using split screen, side by side, or pop-up advertising to advertise any similar product other than SKYFOOD’s in conjunction with offering a SKYFOOD product for sale.

1.2 Main Components

All the components of this machine are made with materials sensibly selected to suit their functions, according to test standards and also Skyfood’ knowhow.

PICTURE 01

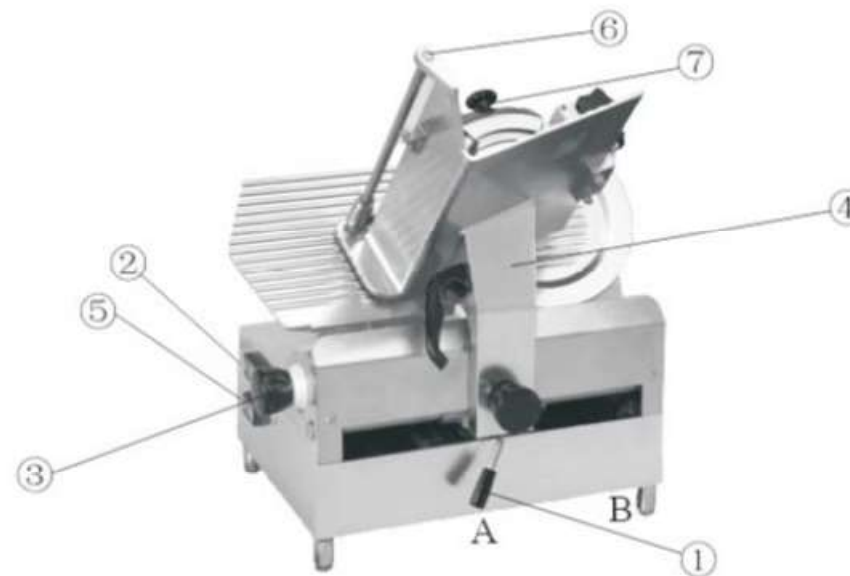

- 01 – Conversion Handle
- 02 – Slicer Engine Switch
- 03 – Thickness Adjusted Handle
- 04 – Out and home frame
- 05 – Out and home control switch
- 06 – Entering the knife and pulling the pole
- 07 – Grinding knife frame

1.3 Technical Characteristics

TABLE 01

CHARACTERISTICS	UNIT	1212E
Voltage	V	110
Power Rating	HP	1/2
Height	inches	33
Width	inches	22
Depth	inches	25
Net Weight	lb	149
Gross Weight	lb	204
Cutting Height	inches	8 1/2
Cutting Width	inches	1/2
Blade Diameter	inches	12
Maximum Cut Thickness	inches	1/2

2. Pre Operation

Put the machine in a steady work table and connect with the ground wire in the back of the machine.

3. Operation

Manual cutting: pull the conversion handle "1" out to "A". At that time, out and home frame is apart from the automatic working pattern. Then press the cutting engine's green button "2" and press the out and home control's engine red stop button "5". Now the machine has entered the manual cutting working pattern.

Automatic cutting: please pull the conversion handle "1" out to "B", press the out and home control switch's "5" green button. At that time, out and home frame has entered the automatic working pattern.

3.1 Cutting

The frozen meat should meet in the foam box or the icebox in the -5°C for thaw for several hours after the meat got from the refrigerator in order to make the meat temperature inside consistent with the outside. You can press the center of the meat lightly by your nail. If you feel the meat is tender, it would be good. According to the experience, the meat in the -5°C to 8°C range is the best time to cut.

Before the machine is working it should be put the lubricant in the pulling pole of frozen meat supplying equipment in order to that the pressed meat plank could send the meat to the knife-edge smoothly. (Do not use the edible oil as the lubricant, such as rapeseed oil, bean oil, etc.)

3.2 Grinding

<1> The knife should grind frequently and lightly. It should clean the smear of the knife before grinding it in case that the oil would smear the grinding wheel. Once the grinding wheel is smeared, please clean it.

<2>After loosening the fixed aim of the grinding knife frame the grinding wheel will lift and circumscribe to the position of grinding knife. Tighten screw down the fixed aim of the grinding wheel.

<3>Turn on the cutting engine switch, and turn off the out and home control engine. At that time, knife just circumscribes to press the grinding wheel frame's handle to the back of the knife blade. It usually needs grinding for more than ten minutes. When the blade is in reverse, it's shapest.

<4> After grinding, please turn off the power and put the grinding wheel frame back

6. Maintenance

<1> Checking and preparing before using

A. Every active place of the machine should inject the lubricant tennly. Especially the oil hole that has the oil mark in the side of the machine. It must use the oil mirror height in the back of the machine. If it is too low, it must inject some oil in the center of the oil mirror (you had better use hyperbola gear oil).

B. Please confirm the blade is sharp. If not, please grind the knife according to the item 3.2 Grinding). Attention: The blade is very sharp, so it should be careful when assembling and cleaning.

C. This machine water-repellent grade is IPX1. It means that it cannot spurt the water directly.

D. If the wires need changing, please contact our factories. Or you could change them by yourselves, please show that the wires are 300/500VX0.75mm---57(RVV).

Plate synchronization belt adjustment:

Please put down the machine, unlade four feet, loosen four nuts, take down the soleplate, separate the upside ride from the downside base, loosen the connected acrial pin, and take the pin. Then you can see the plate's engine in the upside ride and the synchronous belt. You should use the spanner to tighten the adjusted bolt beside the engine to make the belt tighten.

Attention: Do not make it too tight. It should be suitable that it just feel tight by pressing the belt finger.

The way to change the belt:

Please upload the blade, loosen the impacted bolt of the plate's engine, put the belt into the preceding belt of the engine, set the other side of the belt in the engine's axes, and tighter the bolt again.

5. Analysis and Problem Solving

5.1 Problems, Causes and Solutions

The electric fryers have been designed to require minimum maintenance. However, some performance failures may happen due to natural wearing caused by the use of the equipment.

If any problem arises check the table - 03 below, where there are some detailed and recommended possible solutions.

TABLE 03

PROBLEM	CAUSE	SOLUTION
- The cutting engine has the clash after working for a period of time	- The synchronous belt of the cutting plate's engine is loose	- Adjusting the adjusted screw beside the cutting engine yo make the belt tight.
- The engine inside stops working after it goes on working	- The fan-cooled radiator in the machine is broken down, so it cause the temperature is too high that the engine is in the self-protected situation.	- Change the fan-cooled radiator.
- The machine stop running or running slowly.	1. The electrical outlet is not connected very well. 2. Th wire is cutting or the switch is dropping because of the bad transportation. 3. The voltage is not steady.	1. Checking wether the electrical outlet is connecting well. 2. Checking whether every part os connecting well as tje switch is locked well. 3. Make sure that the voltage is steady.
- The meat is not cutting very well. It doest not connect with each other. And the meat cannot drop down. It needs pressing by hand.	1. The frozen meat has frozn in a short time that the meat is to hard. 2. The blade is not sharp enough. 3. The frozen supplying equipment is lack of the lubricant so that it isn't running flexibly. 4. The tightening equipment clamps the meat too tightly.	1. Following the third point about cutting. 2. Following the grinding of knife. 3. Filling some lubricant into the pulling pole for entering knife. 4. Pushing two pressed poles of the clamping equipment to the side of the meat.

4. General Safety Practices

IMPORTANT
If any recommendation is not applicable to your equipment, please ignore it.

The following safety instructions are addressed to both the operator of the machine as well as the person in charge of maintenance.

The machine has to be delivered only in perfect conditions of use by the Distributor to the user. The user shall operate the machine only after being well acquainted with the safety procedures described in the present manual. **READ THIS MANUAL WITH ATTENTION.**

4.1 Basic Operation Procedures

4.1.1 Dangers

Some areas of the electric device have parts that are connected or have parts connected to high voltage. These parts when touched may cause severe electrical shocks or even be lethal.

Never touch manual commands such as switches, buttons, turning keys and knobs with your hands wearing wet clothes and/or wet shoes. By not following these instructions operator could be exposed to severe electrical shocks or even to a lethal situation.

4.1.2 Warnings

- * The operator has to be well familiar with the position of ON/OFF Switch to make sure the Switch is easy to be reached when necessary.
- * Before any kind of maintenance, physically remove plug from the socket.
- * Provide space for a comfortable operation thus avoiding accidents.
- * Water or oil spilled on the floor will turn it slippery and dangerous. Make sure the floor is clean and dry.
- * Before using any commands (switch, buttons, lever), be sure it is the correct one. In case of doubt, consult this manual.
- * Never touch any manual commands (switch, buttons, lever) unadvisedly.
- * If any work is to be made by two or more persons, coordination signs will have to be given for each operation step. Every step of the operation shall be taken only if a sign has been made and responded.

4.1.3 Advices

- * In case of power shortage, immediately switch the machine off.
- * Use recommended or equivalent lubricants, oils or greases.
- * Avoid mechanical shocks, once they may cause damages or bad functioning.
- * Avoid water, dirt or dust contact to the mechanical and electrical components of the

machine.

* DO NOT change the standard characteristics of the machine.

* DO NOT remove, tear off or maculate any safety or identification labels stuck on the machine. If any labels have been removed or are no longer legible, contact your nearest dealer for replacement.

4.2 Safety Procedures and Notes before Switching the Machine ON

IMPORTANT

Carefully read ALL INSTRUCTIONS of this manual before turning the machine ON. Be sure to well understand all the information contained in this manual. If you have any question contact your supervisor or your nearest Dealer.

4.2.1 Danger

An electric cable or electric wire with damaged jacket or bad insulation might cause electrical shocks as well as electrical leak. Before use, check the conditions of all wires and cables.

4.2.2 Advices

Be sure to well understand all the information contained in this manual. Every operation function or procedure has to be thoroughly clear.

Before using any commands (switch, buttons, lever), be sure it is the correct one. In case of doubt, consult this manual.

4.2.3 Precautions

The electric cable has to be compatible with the power required by the machine.

Cables touching the floor or close to the machine need to be protected against short circuits.

The oil reservoirs have to be filled until the indicated level. Check and refill if necessary.

OBSERVATION

For your own safety read all the machine stickers.

4.3 Routine Inspection

4.3.1 Advice

When checking the tension of the belts or chains, DO NOT insert your fingers between the belts and the pulleys and nor between the chain and the gears.

4.3.2 Precautions

Check the motor and sliding or turning parts of the machine in case of abnormal noises. Check the tension of the belts and chains and replace the set when belts or chains show signs of wearing.

When checking the tension of belts or chains DO NOT insert your fingers between belts and pulleys, nor between the chains and gears.

Check protections and safety devices to make sure they are working properly.

4.4 Operation

4.4.1 Warnings

Do not use the machine with long hair that could touch any part of the machine. This might lead to a serious accident. Tie your hair up well and/or cover it with a scarf. Only trained or skilled personnel shall operate this machine.

Never touch turning parts with your hands or any other way , NEVER operate the machine without any original safety devices under perfect conditions.

4.5 After Finishing The Work

4.5.1 Precautions

Always TURN THE MACHINE OFF before cleaning by removing the plug from the socket.

Never clean the machine unless it has come to a complete stop.

Put all the components back to their functional positions before turning the machine ON again.

Check the level of oil.

Do NOT insert your fingers in between belts and pulleys nor chains and gears.

4.6 Maintenance

4.6.1 Danger

Any maintenance with the machine in working situation is dangerous. TURN IT OFF BY

IMPORTANT

Always remove the plug from the socket in any emergency situation.

4.7 Warning

Electrical or mechanical maintenance has to be undertaken by qualified personnel. The person in charge of maintenance has to be sure that the machine is under TOTAL SAFETY conditions when working.