

EBF-815 / ETF-810 Parts & Accessories

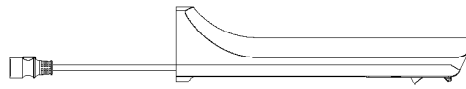

Spout Assembly
EFP-122A

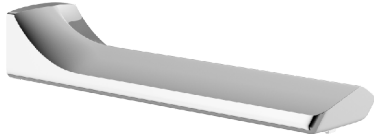

EFP-114A

EBF-815 Wall Mount, battery
ETF-810 Wall Mount, hardwired

SPOUT ASSEMBLY			
Description		Code No.	Part No.
Spout Assembly EBF-815 /ETF-810		03150019	EFP-122A
Wall Mounting Kit 815/810		33620004	EFP-124A
Sensor and Cable Assembly		3315431	EFP-114A
SPRAYHEAD OPTIONS			
Description	Type	Code No.	Part No.
0.35 GPM/1.3 Lpm	MLM	3362005	EFP119
0.5 GPM/1.9 Lpm	MLM	3362001	EFP120

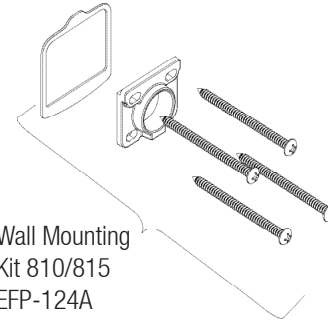

Wall Mounting
Kit 810/815
EFP-124A

BELOW DECK ASSEMBLIES		
Description	Code No.	Part No.
Control Box No Turbine	0367039	EFP39A
Control Box Turbine 0.5 gpm	0367040	EFP40A
Control Box Turbine 1.5 gpm	0367011	EFP11A
Braided Flexible Hose 36"	0315322	EFP1018
Control Box Cover w/Screw	0367010	EFP10A
Solenoid Assembly	0367103	EFP103A
Battery Pack	3324113	EFX8A
Double Inlet Tee Filter Assembly	0367028	EFP28A
BDM & Single Inlet Tee Filter Assembly Kit	0367099	EFP99A
BDT & Single Inlet Tee Filter Assembly Kit	0367100	EFP100A
Replacement Filter Pack-(5) Filter (5) Large O-rings (5) Small O-rings	0367101	EFP101A
24 VAC Power Harness Assembly	0367098	EFP98A
110V/6 VDC Power Supply	0362006	SFP6
100-240 VAC/6 VDC Power Supply	0362016	SFP36
120/24 VAC Power Supply	0365534PK	ETF-233
120/24 VAC Power Supply (Canada) Plug-in	0365879	ETF-416
120/24 VAC Power Supply (Box Mount)	0345370PK	EL-248-40
Extension Cable	0362017	SFP37
Splitter Cable	0362018	SFP38
Gang Adapter Kit	0362035	SFP35A
Faucet to Module Ext. Cable*	0367113	EFP-113-A



EFP39A
EFP40A
EFP11A

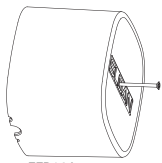

EFP10A
Cover and Screw ONLY



EFX8A



EFP103A

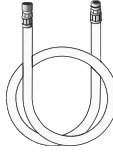

EFP1018



SFP6

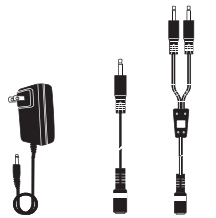

SFP35A



EFP98A



EL-248-40



ETF-233



ETF-416

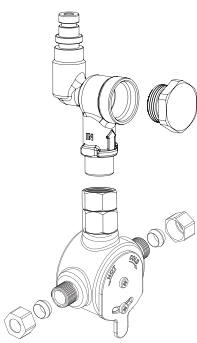

EFP99A

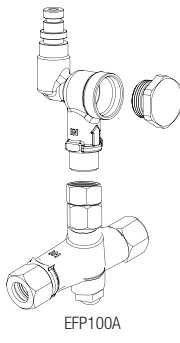

EFP100A

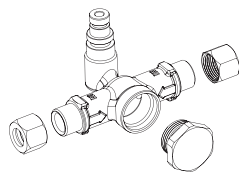

EFP28A



EFP101A

NOTE: Some parts and accessories must be ordered separately * Not shown

**TROUBLESHOOTING INSTRUCTIONS FOR OPTIMA SENSOR ACTIVATED LAVATORY FAUCETS
WITH THE NEW OPTIMA CONTROL BOXES AND THE SLOAN CONNECT SMARTPHONE APP.**

NOTE: To automatically check battery strength, troubleshoot, diagnose and report faucet issues with a wireless device, use the Sloan SmartPhone APP. The APP is available free-of-charge at the Apple iPhone APP store for iOS devices or the Google Play APP store for Android devices. For more information about the APP and its capabilities please visit www.Sloan.com.

FAUCET TROUBLESHOOTING GUIDE

LED indicator light in the IR (infrared) sensor is red.

- A. Battery power is low.
Install four (4) new AA sized alkaline batteries. Check that the orientation of each battery matches the positive (+) and negative (-) symbols shown in the bottom of the battery compartment.
Re-attach battery compartment to control module. Green LED will illuminate. If the Green LED does not illuminate, remove battery compartment for 10 seconds and return into place.

Faucet DOES NOT function.

- A. Batteries not installed or are exhausted.
Install four (4) AA sized alkaline batteries. Check that the orientation of each battery matches the positive (+) and negative (-) symbols shown in the bottom of the battery compartment. Reattach battery compartment to control module. Green LED will illuminate. If the Green LED does not illuminate, remove battery compartment for 10 seconds and return into place.
- B. Power Cable not installed (Hardwire models).
Install power cable and check connection.
- C. Sensor Cable not installed.
Install sensor cable and check connection. Confirm connection guide markings are aligned.
- D. Sensor range is set too short and is not detecting the target.
Increase sensor detection range.

Sensor is activated but faucet DOES NOT deliver water.

- A. Faucet has initiated its adaptive sensing calibration program.
Wait 60 seconds before activating faucet.
- B. Solenoid Cable not connected.
Check solenoid cable connection. Confirm connection guide markings are aligned.

Sensor Range Requires Manual Adjustment.

Sensor Range is measured in units from 1 to 5, with 1 being closest to the faucet and 5 being farthest from the faucet. The factory default Sensor Range is 3.

- A. To determine what the current Sensor Range setting is, press the red "Sensor" button on the upper right hand corner of the Optima Control Box for 1 second. Five seconds after pressing the button, the green LED beside it will blink to indicate the Sensor Range setting. For example, if it is set at 2, the green LED will blink 2 times.
- B. To adjust the Sensor Range, press and hold the red "Sensor" button for three seconds and release once the green LED comes on to indicate that you are in Sensor Range adjustment mode. Then press the "Sensor" button one second at a time for however many times you wish to increase the range. For example, if the Sensor Range is set at 2 and you wish to increase it to 4, press the "Sensor" button two times for one second each time..
- C. If you wish to decrease the Sensor Range, follow the same procedure to enter into Sensor Range adjustment mode, and then press the "Sensor" button one second at a time. The button is designed to go up to 5 units and then back down to 1 unit. For example, if the Sensor Range is set at 4 and you wish to decrease it to 2, press the "Sensor" button three times for one second each time.
- D. To conform your changes, wait 5 seconds and then press the red "Sensor" button on the upper right hand corner of the Optima Control Box for 1 second. Five seconds after pressing the button, the green LED beside it will blink to indicate the Sensor Range setting. For example, if it is now set at 2, the green LED will blink 2 times.

**Solenoid produces an audible "CLICK" when an object is placed in the detection zone of the sensor but
NO water flows.**

- A. Water supply to faucet is not open.
Open supply stop(s).
- B. Inlet fitting filter is clogged.
Remove, clean, and reinsert. Replace with EFP101A solenoid filter kit if necessary.
- C. Aerator or spray head is clogged.
Remove, clean, and reinsert.