



---

## **OPERATOR/INSTALL MANUAL**

### **SP-75 & HE-6 REMOTE PULPING SYSTEM**





To better serve your needs in the future, please record your equipment's information below.

Model Number: SP-75 & HE-6R	Serial number:
Service Company:	Service Phone Number:
Rep/ Dealer:	Rep/Dealer Phone number:
Somat Service Dept: 800-237-6628 x176	
Somat Parts Dept: 877-333-1863	customer@hobart.com

To expedite service or parts, please have the above information available before you call. The serial number of our machine is located inside of the main electrical control panel of your Somat equipment.

## **SOMAT COMPANY MANUFACTURERS WARRANTY**

SOMAT COMPANY warrants each new product manufactured by it to be free from defects in material and workmanship under normal use and service for a period of one (1) year from the date of initial startup or 18 months from date of shipment, whichever occurs first. "Normal use and service", with respect to Pulpers, Food Grinders, Dehydrators, Hydra-Extractors, Waste Handling and Processing Systems, shall mean the handling only of waste items of the types approved by SOMAT® therefore and within the **LIMITATIONS THEREIN** set forth, its obligation under this warranty being limited to repairing or replacing any part or parts thereof, free of charge **INCLUSIVE** of labor to remove and replace, f.o.b. factory from which shipped. This warranty shall not apply to any product or part which shall have been repaired or altered by any person not employed or retained by SOMAT®, so as in the judgment of SOMAT® to affect its operation and reliability, nor which has been installed, operated, or maintained contrary to SOMAT® OPERATION or PREVENTIVE MAINTENANCE INSTRUCTION MANUALS or to other written instructions or drawings approved by SOMAT®, nor which has been subject to misuse, negligence, or accident. This warranty shall not apply should the SOMAT® System be initially started up without a duly authorized SOMAT® representative present.

Except as herein expressly stated, no warranty, expressed, implied or by law, (including but not limited to any implied warranty of merchantability or fitness for a particular purpose), is made by SOMAT; and in any event SOMAT'S liability, whether in contract, tort, strict liability, or under any warranty, or otherwise, shall not exceed the purchase price received by it and shall in no event include any consequential, incidental, punitive or other special damages. No change in this warranty and limitation of liability and substitute therefore (whether incorporated in a purchase order or otherwise) shall be effective unless specifically set forth in a written instrument signed by an officer of SOMAT®.

## **STANDARD EQUIPMENT WARRANTY EXCEPTIONS**

Warranty work is for defective parts or workmanship on Somat original equipment and does not cover wear items, cleaning, or problems resulting from improper use by the end user. Any cutting blade, rotating blade, impact bar, sizing ring, or any other cutting mechanism part damaged due to improper waste materials or any cutting mechanism part that has been worn due to misuse may not be covered under Somat warranty. Any motor, solenoid valve, electrical panel, junction box, or any electrical device in Somat equipment that has been damaged by water, improper installation, electrical short from surges or storm related strikes may not be covered under Somat warranty. Extractor screws and screens will not be warranted for wear. Defective or workmanship related extractor parts must be submitted to Somat for verification before credit will be issued. Line clogs that are resultant of improper feeding, clogs due to improper line installation, leaks in areas that Somat did not fabricate (i.e. table connection), leaks due to improper pipe bracing, tampering with system settings, jams due to non-waste stream items or jams due to dull/missing cutting mechanism parts, alterations to equipment without prior Somat approval or any other action that could cause harm to the equipment's performance may not be covered by Somat warranty.

*Table of Contents:*  
 SP-75S, SP-75UDT, HE-6

**Introduction..... 2**  
     Safety Precautions and Warnings..... 5-7  
     General Description & Definitions..... 8-11

**Installation..... 12**  
     Unpacking..... 13  
     Mechanical Installation..... 14-16  
         *High Tank Models*  
         *UDT Models*  
         *Mounting of Grabber Magnets*  
     Plumbing Installation..... 17-18  
         *Fresh Water*  
         *Hydra-Extractor Overflow and Pulper Drain*  
         *Return Piping for Units With a Tray Feed Only*  
         *Return Piping for Units with a Trough*  
     Electrical Installation..... 19-20  
         *Panel & Optional Remote PBS Mounting*  
         *Supplying Som-A-Trol with Power*  
         *Remote Push Button Station*

**Start-up..... 21**  
     Warranty Registration Form..... 23

**Operation..... 24**  
     Typical Startup And Operating Procedure..... 25-26  
     Shutdown Procedures..... 27  
     Light Codes..... 28  
     Special Operating Procedures..... 29

**Cleaning Your System..... 30**  
     Cleaning Instructions..... 31  
     Cleaning The Pulper..... 31  
         *Cleaning the Hydra-Extractor*  
     Cleaning Compounds..... 32

**Maintenance..... 33**  
     Periodic Maintenance and Inspection..... 34-35  
     Component Removal and Replacement..... 36-41

**Troubleshooting..... 42**

**Display Module Instructions..... 46**

## Safety Precautions and Warnings



**READ THE MANUAL** COMPLETELY BEFORE ATTEMPTING TO OPERATE THE UNIT.

**HIGH VOLTAGE!** DO NOT PERFORM ANY REPAIRS TO MOTORS OR CONTROL SYSTEMS WITHOUT TURNING OFF THE MAIN POWER.

ALWAYS **TURN THE MAIN POWER OFF** AND LET ALL MOTORS COME TO A STANDSTILL BEFORE DOING ANY MAINTENANCE ADJUSTMENTS OR CLEANING OF THE UNIT.

BEFORE STARTING, BE SURE **ALL PERSONNEL ARE CLEAR** OF MOVING PARTS.

KNOW LOCATION AND FUNCTIONS OF ALL **START/STOP BUTTONS** AND SAFETY SWITCHES.

DURING PERIODIC MAINTENANCE, **CHECK ALL SAFETY SWITCHES** TO BE SURE THEY ARE OPERATING PROPERLY.

**DO NOT REMOVE** OR ALTER GUARDS.

**DO NOT REMOVE** SAFETY LABELS. IF LABELS ARE MISSING OR DESTROYED, CONTACT FACTORY FOR REPLACEMENT.

**DO NOT OBSTRUCT** ELECTRICAL PANELS OR PUSH BUTTONS.

**GOOD HOUSEKEEPING** IS THE MOST IMPORTANT SAFETY PROCEDURE.

## Safety Precautions and Warnings

**This equipment has locations which are hazardous and cause severe injury or death if warnings are not followed. Always turn off power before reaching into any unit! Maintenance to be performed by trained and authorized personnel only.**



This equipment has moving parts operating at high speeds. Serious injury can occur if warnings are not followed.

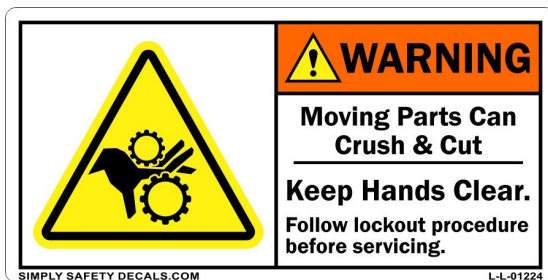

This equipment has moving parts that can crush and cut. Do not alter safety devices or guards. Do not reach into any part of the unit with the power turned on.



This equipment has moveable lids protecting you from moving parts. Do not alter safety devices or guards. Do not reach into any part of the unit with the power turned on.

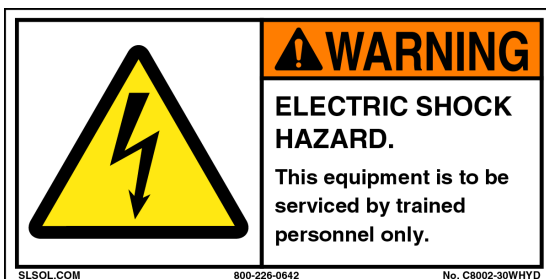

This equipment has High Voltage! Only trained and authorized personnel should perform maintenance on the electrical components of this machine.

# Caution

Damage will occur to this equipment if unsafe objects are fed into the machine(s). Keep these items out of the machine(s) to avoid component failure and unwanted downtime. When in doubt, keep it out of the machine(s)!



**ALWAYS TURN POWER OFF BEFORE SERVICING PULPER!**

# GENERAL DESCRIPTION

The SOMAT® system prepares solid waste materials for disposal by transforming the materials, with water, into a pulp. This transformation takes place in a unit called a Pulper which is designed to pulp all forms of paper, plastic, card board and food waste. The waste material is fed manually or automatically to the Pulper. The continual down flow of water and the rotation of the Pulper impeller create a strong vortex action which pulls the waste down against the cutting blades of the impeller. The resultant slurry is then forced through a perforated stainless-steel Sizing Ring surrounding the impeller.

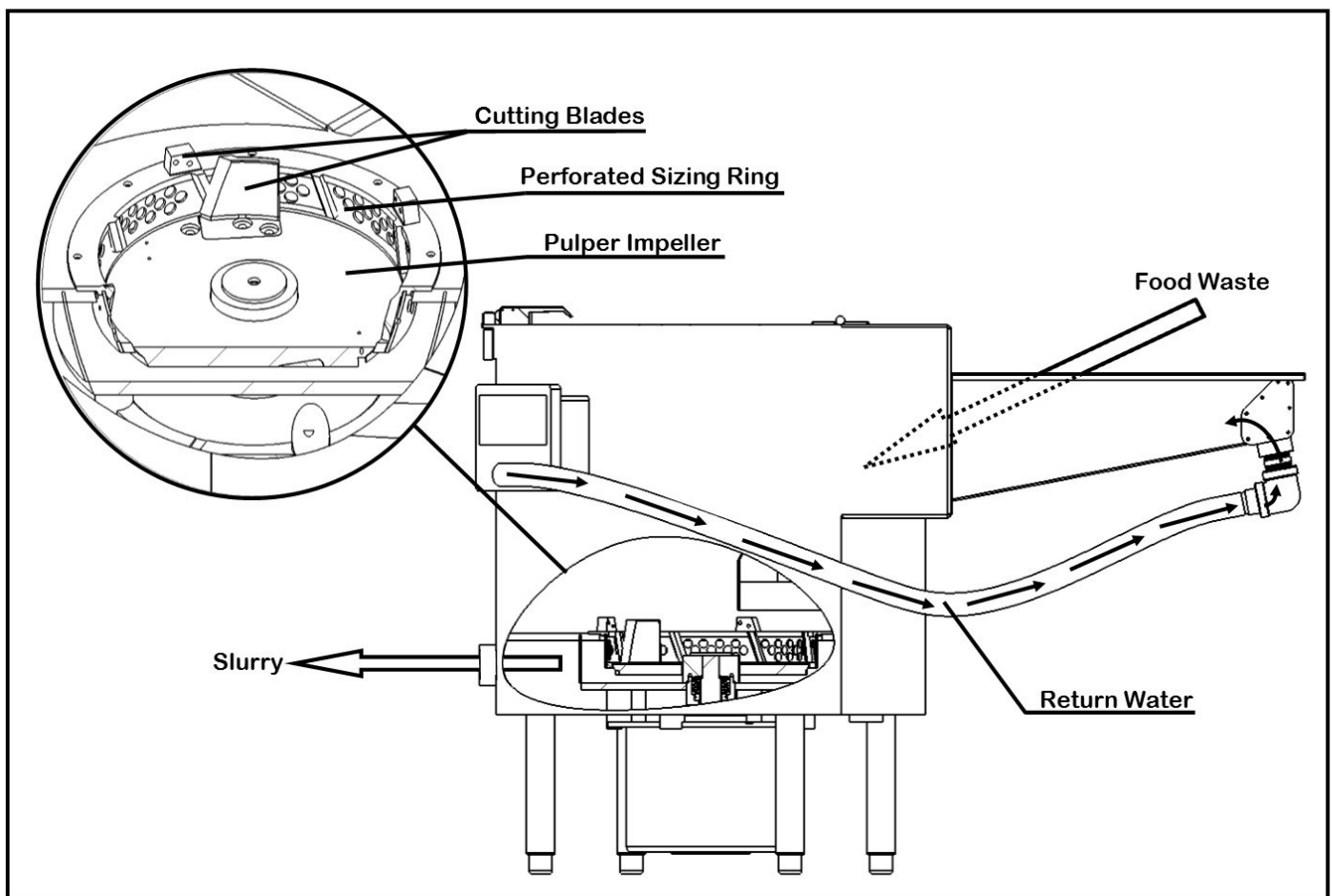

The SOMAT® System is designed to pump the mixture of macerated solids and water, called slurry, to the Hydra-Extractor® where the slurry is reduced to a semi-dry pulp. Within the Hydra-Extractor®, the slurry is carried by a helicoid screw within a perforated tubular screen. The water passes through the screen and is pumped back to the pulping unit. The solids continue up the helicoid screw to a compression chamber or plug area where additional water is removed by extrusion. The solids in this area are called the plug. This plug is broken up at the Hydra-Extractor® discharge opening by a cutter and the pulp then falls out of the discharge chute.

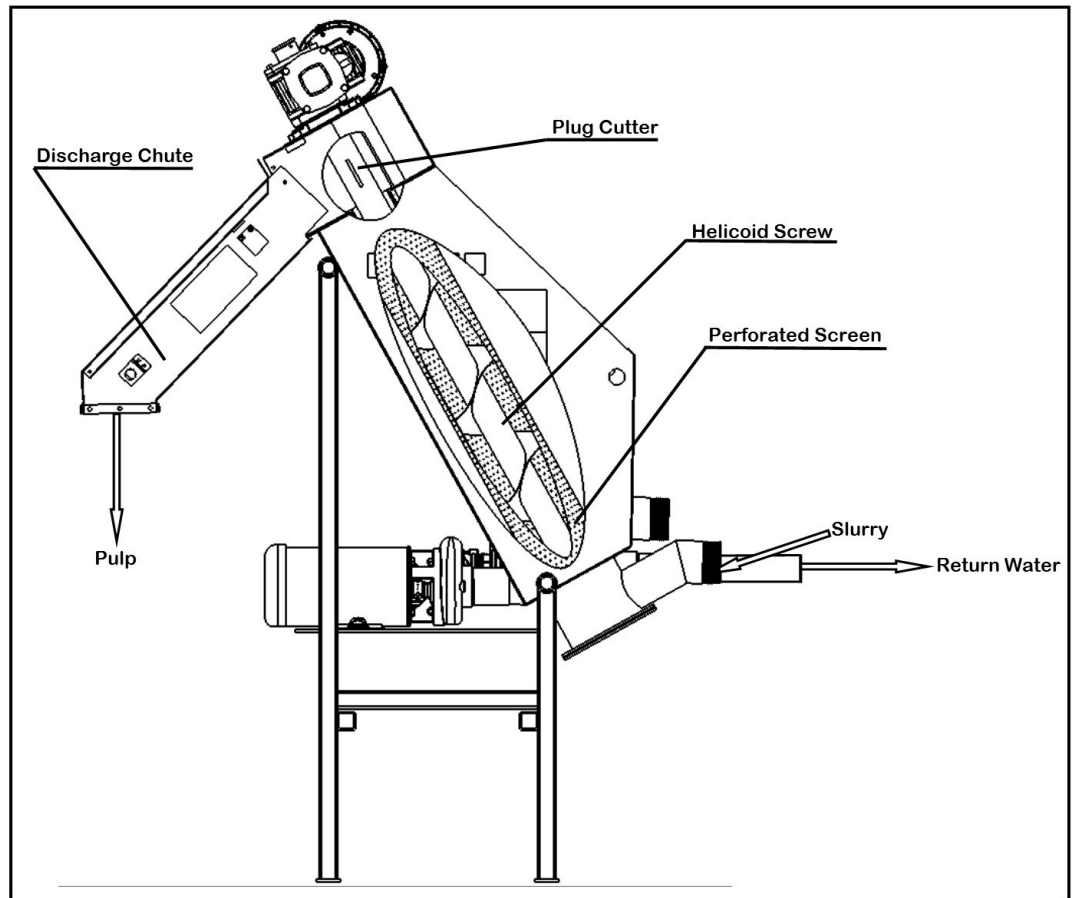

### **TYPICAL REMOTE HYDRA-EXTRACTOR®**

This system can reduce the volume of average non-compacted waste by approximately 80 percent.

The system is powered by electric motors with the associated controls housed in Som-A-Trols® (electric control panels).

In addition to the basic system as discussed to this point, numerous additional items of equipment may or may not be required to comprise a specific system.

## **DEFINITIONS – GENERAL**

1. Pulper - device that contains an impeller and sizing ring to grind solid waste. The resultant mixture of waste particles and water is called slurry.
2. Hydra-Extractor® - Inclined screw-type press for removing transport water from pulp.
3. Slurry - A water solution containing a low percentage of suspended solids.
4. Pulp - Semi-dry solid from which transport water has been extracted.
5. Som-A-Trol® - Electrical control panel, including motor starters and sequencing controls for automatic operation of the SOMAT® system.
6. Slurry Pump - Specially designed pump used to transport slurry from a SOMAT® Pulper to Hydra-Extractor®.
7. Return Pump - Specially designed pump used to return water from Hydra-Extractor® to SOMAT® Pulpers.
8. Water Level Control - a PLC controlled function utilizing time-based programming.
9. Chemical Additive Pump - A proportioning type Additive pump that adds de-foaming, deodorizer, and/or buffering solutions to the process water.
- \*10. Pulp Screw Conveyer– Transport screw with discharge ports throughout its length for even distribution on large haul-away containers.
- \*11. Distributing Type Pulp Screw Conveyer– Transport screw with discharge ports throughout its length for even distribution on large haul-away containers.
- \*12. Water Economizing Tank– Reservoir for return water used in large systems.

**\*Optional equipment which may not be furnished with your pulping system.**

## **DEFINITIONS – COMPONENTS**

### **SOMAT® PULPER:**

1. Tank - Pulping or grinding chamber of the SOMAT® Pulper.
2. Impeller - Rotating metal plate with Cutting Blades and Tungsten Carbide teeth which de-fiber and pulp the waste and along with the Security Ring provides a shearing action for non-fibrous waste.
3. Security Ring - Perforated stainless-steel ring surrounding the impeller through which all slurry must pass after waste is pulped. Dimensions of security ring holes controls particle size of materials leaving the Pulper.
4. Junk Box - Chamber in bottom of tank that segregates non-pulpable materials from tank.

### **HYDRA-EXTRACTOR®:**

1. Screw - Vertical helix which lifts and compresses solids from the slurry and permits water to drain off by gravity.
2. Screen - Mesh screen that surrounds the screw, through which water drains off.
3. Plug - Mass of pulp extending beyond last helix of the screw. The force required to extrude the plug squeezes additional water from pulp.
4. Brush - Nylon brush attached to edge of screw helix which serves to clean the screen.
5. Plug Cutter – Assists in breaking apart waste to discharge down the chute

### **GENERAL:**

1. Throttling Valve - Full ported gate valve used to control water flow.
2. Timer - Electrical device used to automatically shut down the SOMAT® System at a pre-determined time.
3. Fresh Water Solenoid - Electric valve used to control fresh water make-up to the SOMAT® System.
4. Motor Operated Valve - (MOV) Electric valve used to control return water flow in the system.
5. PLC- Computer controller designed to handle pulper and extractor operation.

# Installation

# UNPACKING

The crate containing your SOMAT® Pulper will contain the following items:

1. Pulper
2. Tray, if so equipped
3. Som-A-Trol® Panel
4. Pulper Return Lining Piping Assembly
5. Pulper Slurry Pump Piping Assembly
6. Discharge Chute W/Hardware
7. Hydra-Extractor Som-A-Trol Panel
8. Hydra-Extractor Return Pump Piping

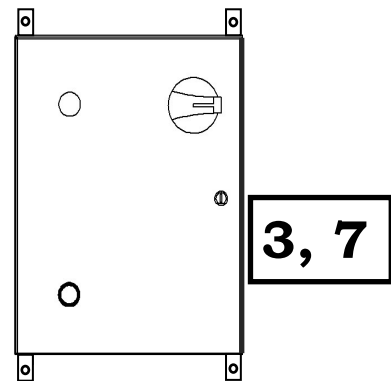
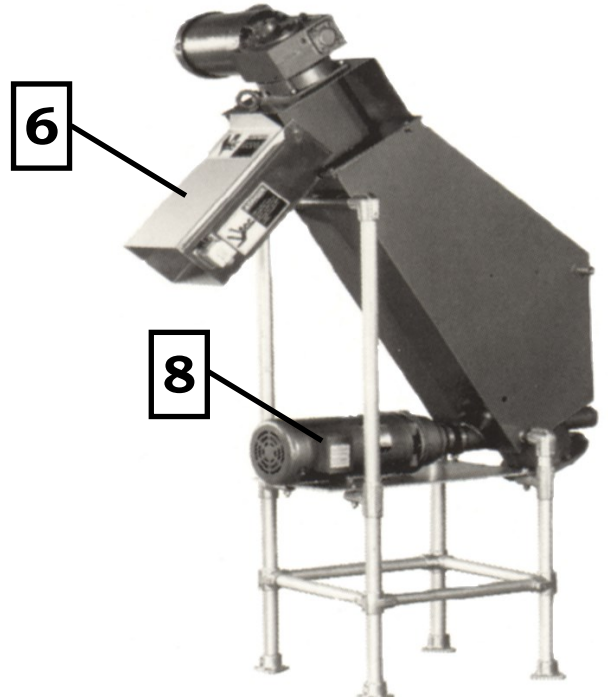
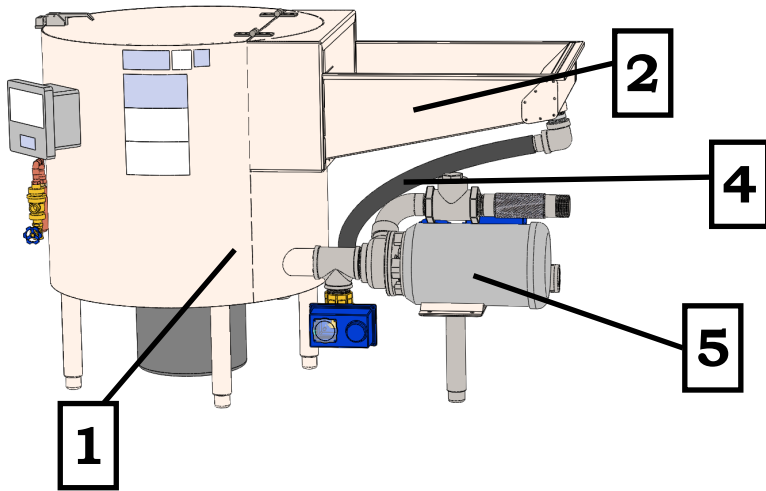

## Misc. parts box containing:

### ALL UNITS:

Anti-Vibration Pads

Installation Drawings (Picture Not Available)



**UDT UNITS ONLY:**

1. Stainless Steel Lid
2. Stainless Steel Adapter (Unless shipped directly to table manufacturer).
3. UDT Gasket (on unit)

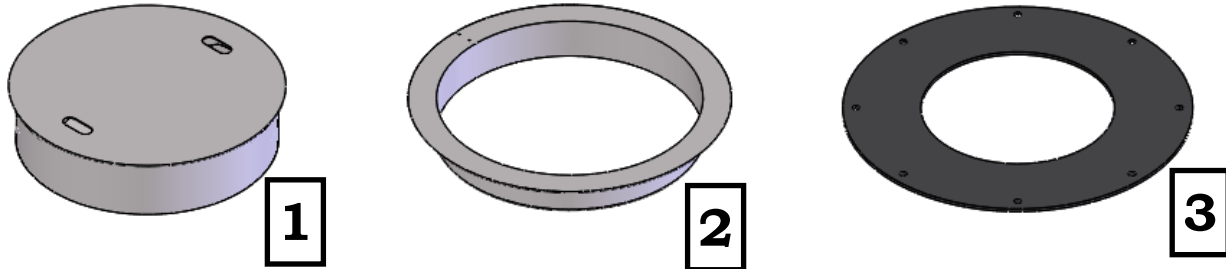

**TRAY ONLY:**

1. Gasket & Hardware
2. Return Water Assembly

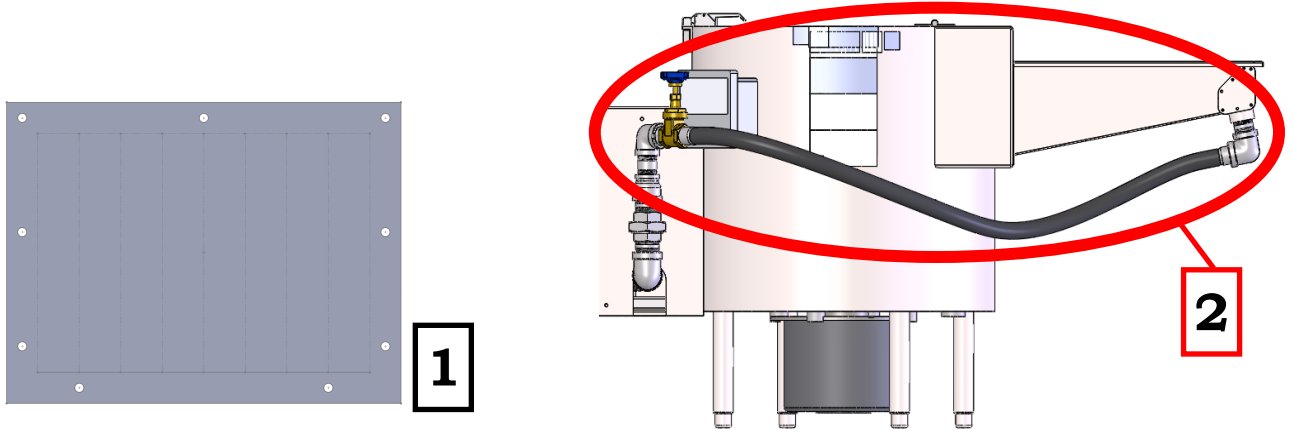

**TROUGH ONLY:**

1. Trough Gasket & Hardware
2. Trough Nozzles & Throttling Gate Valves  
(See Installation Drawing for quantity)

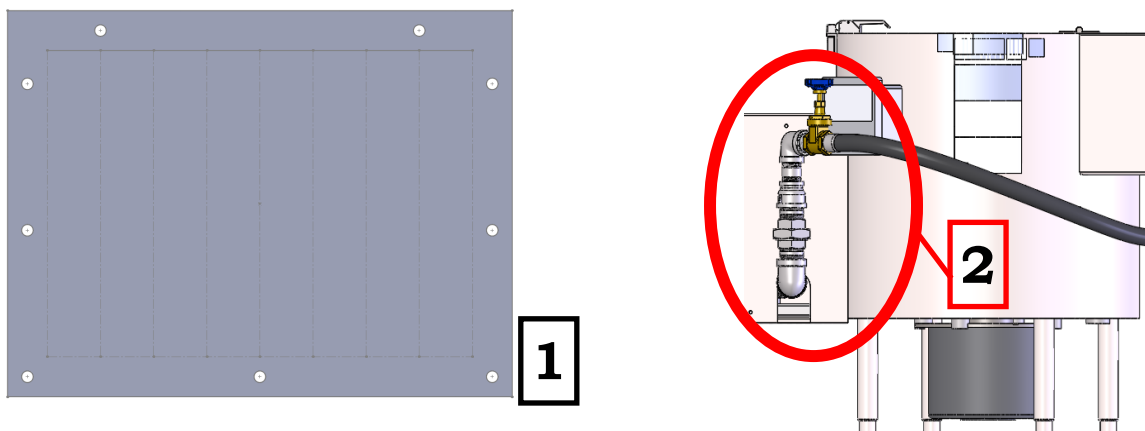

**OPTIONAL EQUIPMENT:**

1. Remote Push Button Station
2. Trough Magnet & Hardware (Picture Not Available)
3. Feed hood
4. Stainless Steel Angular Stand W/Hardware
5. Weather Seals
6. Through-Wall Extractor Chute

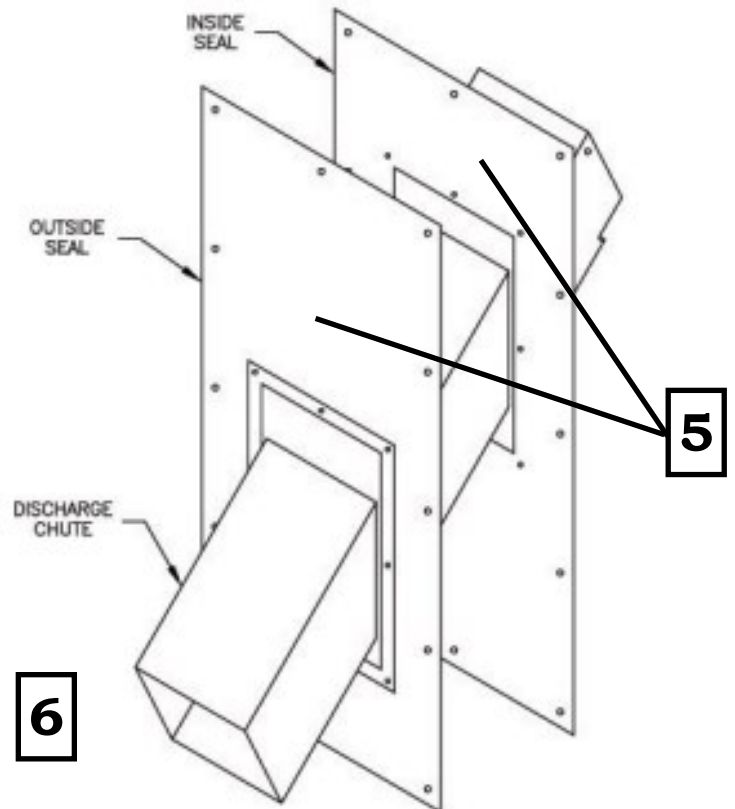
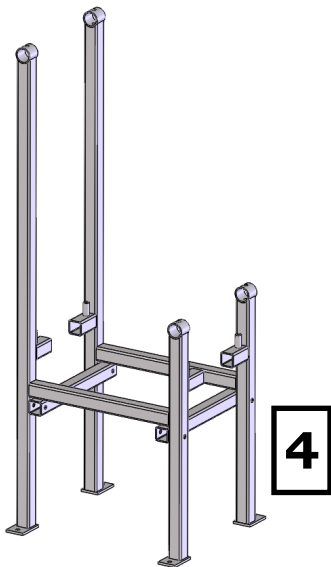
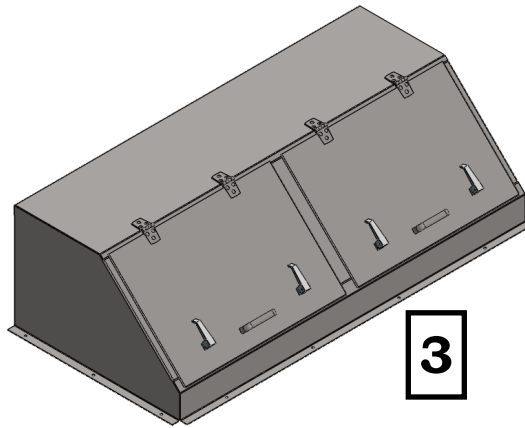
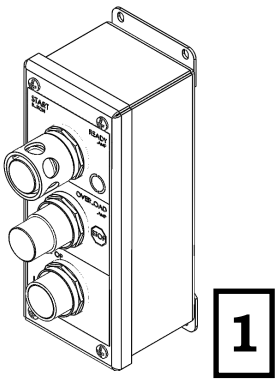

# PULPER INSTALLATION

## HIGH TANK MODELS:

- 1) Put the pulper into position as shown on the Installation Drawings.
- 2) Place the Anti-Vibration Pads under each leg of the Pulper and Hydra-Extractor®.



- 3) TRAY FEED UNITS ONLY - Install the tray to the Pulper (if it was not already installed at the factory) using the provided gasket material and hardware.

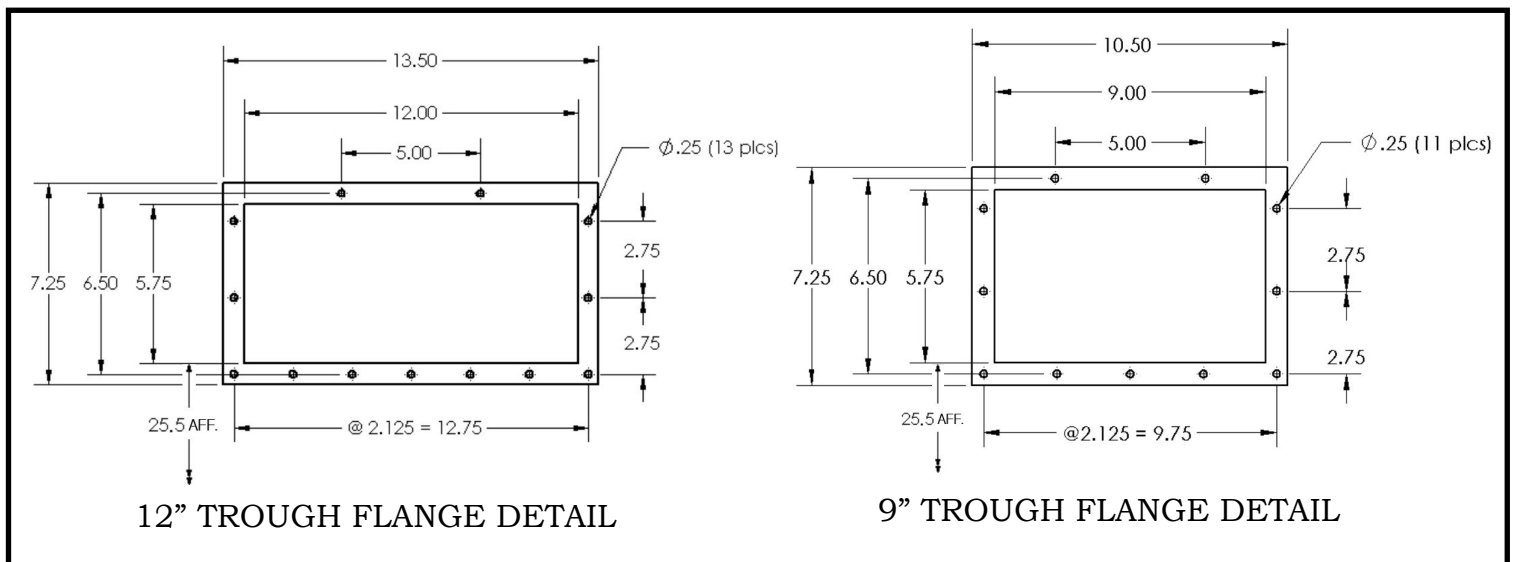

- 4) TROUGH FEED UNITS ONLY - Install the provided trough gasket between the Pulpers inlet and the trough outlet and secure with the provided hardware. Holes will need to be drilled in the field.

## UDT MODELS:

- 1) Cut a hole in the top of the table as shown on the drawing (If not done by table manufacturer).
- 2) Center the provided UDT Table Adapter beneath the opening and weld it into place as shown. Please follow print detail for welding instructions (if not done by table manufacturer).
- 3) Put the Pulper into position.
- 4) Trim UDT Rubber Gasket to fit tightly around the pulper lid. 
- 5) Place the anti-vibration pads under each leg of the Pulper and Hydra-Extractor®.
- 6) Adjust the Pulper and Hydra-Extractor® legs so that the rubber UDT gasket provides a water tight seal with 2" clearance between Pulper top and the underside of the table.
- 7) Install the provided trough gasket between the Pulpers inlet and the trough outlet and secure with the provided hardware. Holes will need to be drilled in the field.

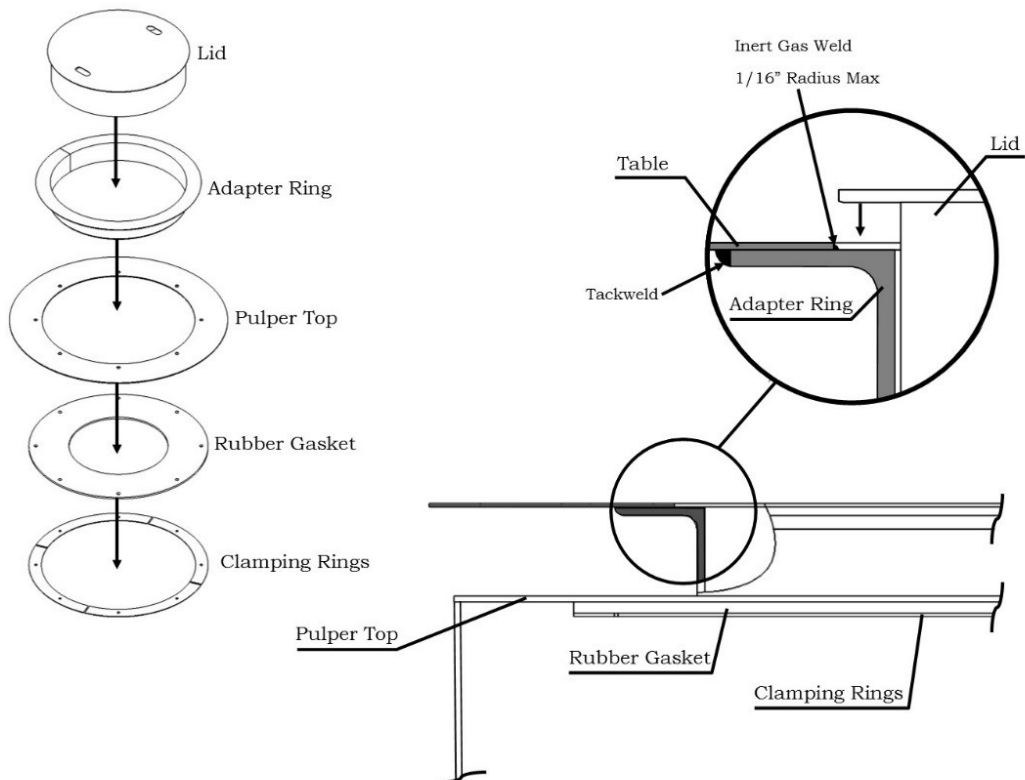

REV	DESCRIPTION	DATE	APPROVED

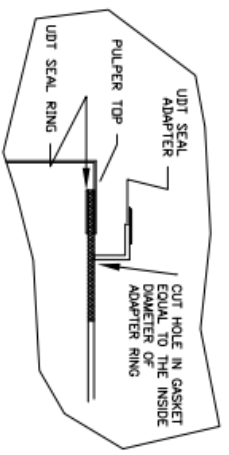
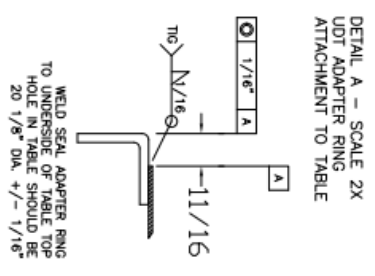
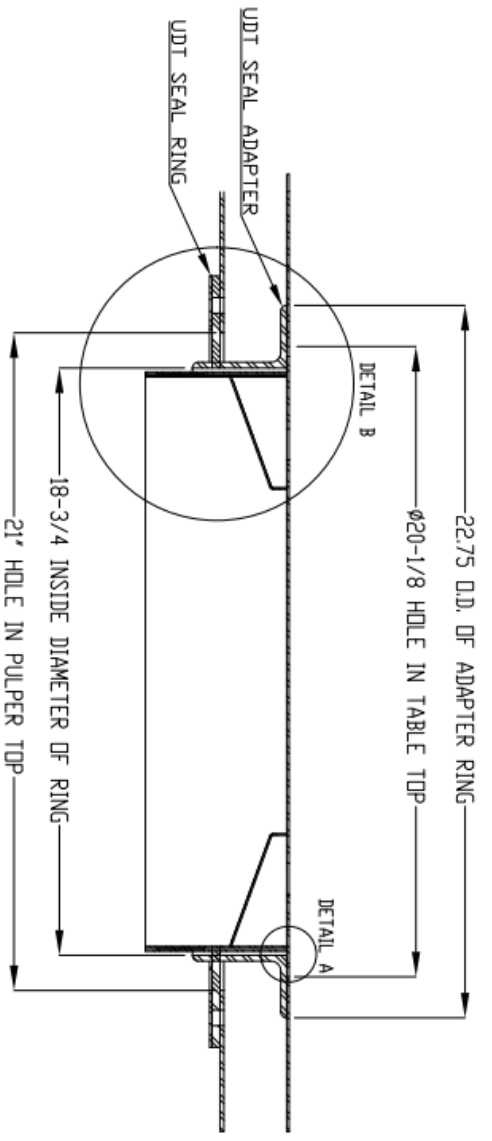

**INSTALLATION OF UDT GASKET/FIT TO UDT ADAPTER RING**

THE UDT GASKET IS HELD TO THE UNDERSIDE OF THE PULPER TOP BY THE TWO HALVES OF THE TOP SEAL RING AND WELD STUDS. ELEVATE THE PULPER UNTIL THE GASKET IS IN CONTACT WITH THE BOTTOM EDGE OF THE UDT ADAPTER RING. FROM THE INSIDE OF THE PULPER, CUT A HOLE IN THE GASKET USING THE ADAPTER RING AS A GUIDE(ROUGHLY 18 3/4 $\phi$ ). ELEVATE THE PULPER THE REMAINDER OF THE WAY SINKING THE ADAPTER RING INTO THE HOLE IN THE GASKET.

**\*\*\*IMPORTANT\*\*\*** THE CIRCLE CUT MUST BE SMOOTH, JAGGED EDGES WILL ADVERSELY AFFECT THE SEALING CAPABILITY OF THE GASKET.

<p>UNLESS OTHERWISE SPECIFIED DIMENSIONS ARE IN INCHES TOLERANCES</p> <p>MACHINING:            WELDMENTS: XX ±                    ± XXX ±                  ± ANGLES:                CHAMFERS:            ±</p> <p>UNLESS OTHERWISE SPECIFIED, MACHINED SURFACE FINISH IS 25 RMS BREAK SHARP EDGES .005-.015 DUE TO THE EFFECTS OF HEAT TREATING AND PLATING</p>		<p><b>NOTICE</b></p> <p>The SPC-75 is a proprietary design of Somat Company. It is not to be copied, reproduced, or used in any way without the written permission of Somat Company, 165 Independence Court, Lancaster, PA 17601.</p> <p>DRAWN BY: RSH CHECKED BY: DATE: 06/25/19 ASSEMBLY:</p>	
<p><b>somat</b> ORIGINAL COMPANY, AND ALL RIGHTS RESERVED</p> <p>SOMAT COMPANY WASTE HANDLING SYSTEMS 165 INDEPENDENCE COURT LANCASTER, PA 17601</p>		<p>LID, GASKET &amp; RING INSTALL SP-75 &amp; SPC-75</p> <p>SIZE: FSCM NO.            DWG NO. SCALE: 1/4"            WEIGHT:            SHEET: 1 OF 1</p>	

## HYDRA-EXTRACTOR INSTALLATION

- 1) If so equipped, attach stainless steel angular stand to assembled Hydra-Extractor using provided 9/16" bolts.
- 2) Move the assembled Hydra-Extractor into position as shown on the installation drawings.
- 3) Install vibration pads under foot pads.
- 4) Install discharge chute and optional weather seal.
- 5) Secure Hydra-Extractor to finished floor.

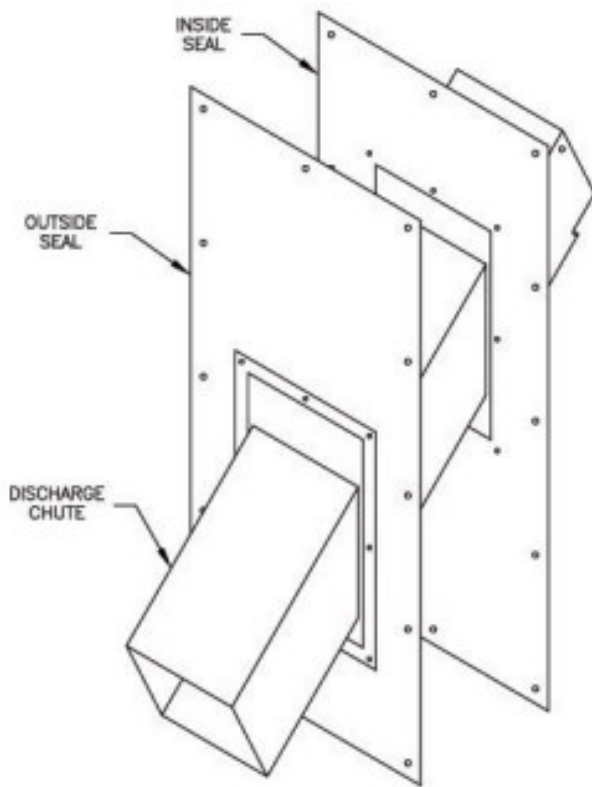

TYPICAL INSTALLATION  
(WALL NOT SHOWN FOR CLARITY)

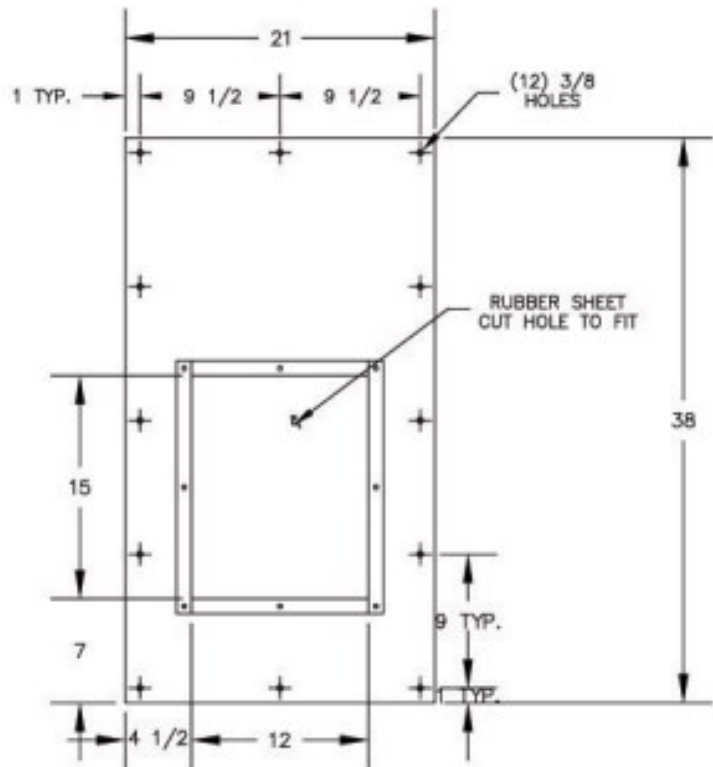

DIMENSIONAL DETAIL

**MOUNTING OF THE GRABBER MAGNETS:**

Preferred: Locate per detail below and weld into place.

Optional: Drill four 7/32" diameter holes into the trough as shown below. Seal the heads of the provided screws with silicone and attach the magnet.

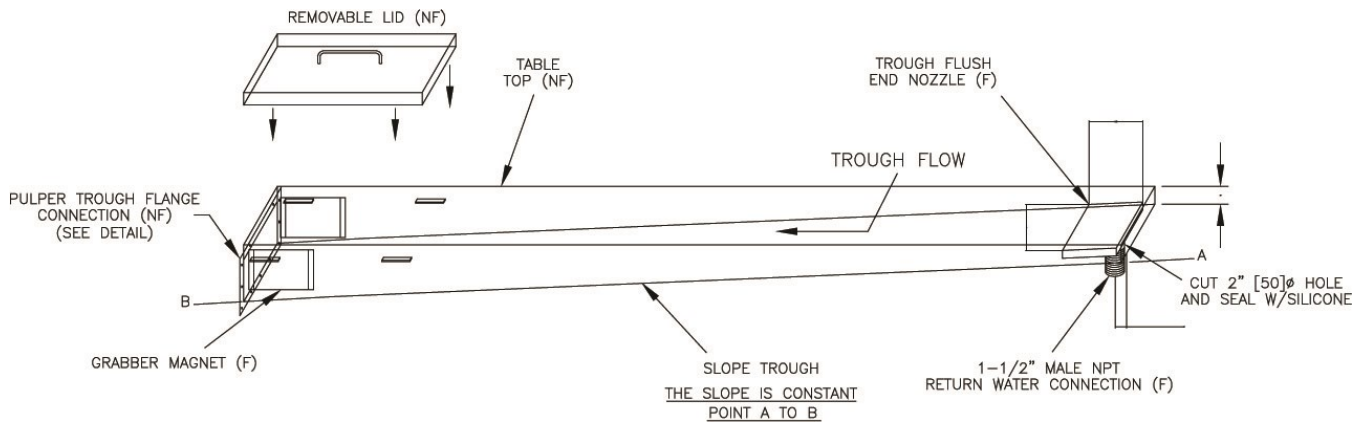

**RECOMMENDED POSITION OF THE GRABBER MAGNETS**

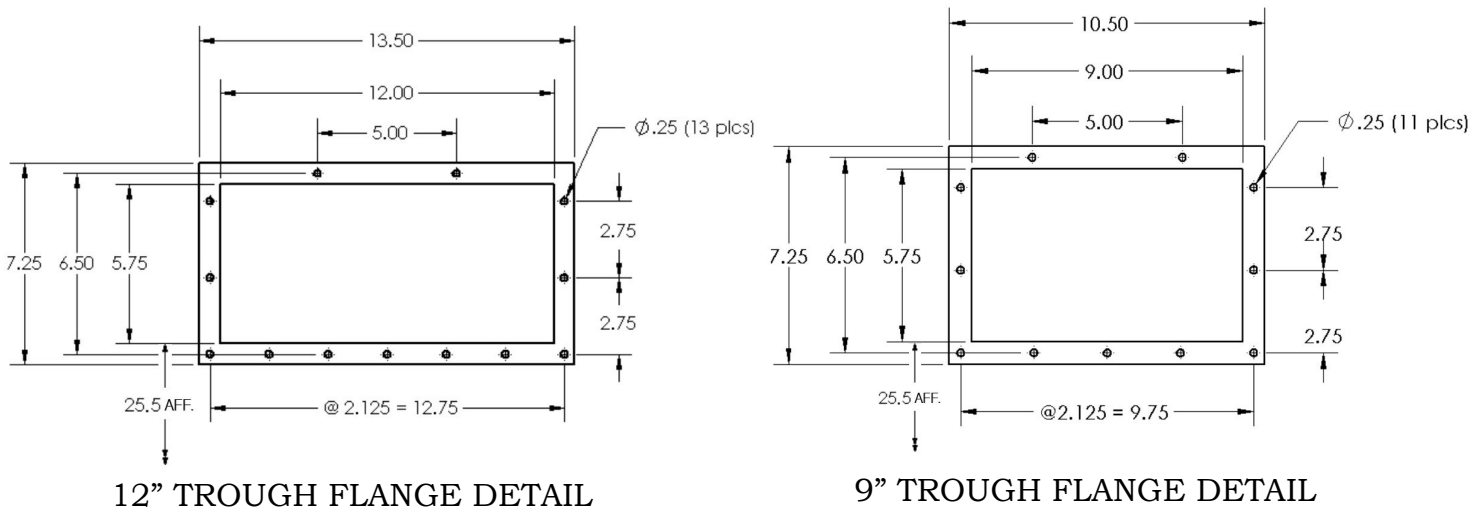

**MOUNTING DETAIL OF TROUGH**

## PLUMBING INSTALLATION

**Check local codes regarding the proper backflow prevention devices to be installed.**

- 1) All interconnecting piping, fresh water lines, and drain lines are NOT supplied by Somat.
- 2) Pipe sizes to be in accordance with Somat recommendations.
- 3) Slurry and return water piping to be Type L Copper, stainless steel, OR equal **(PVC PIPING NOT ACCEPTABLE)**.
- 4) Slurry lines must not include any valving except those authorized by Somat.
- 5) All fittings must be pressure rated drainage type (See Below) and kept to a minimum. Maximum turns allowed 10 feet per 100 feet. Recommend use of two 45° elbows. Use elbows only to change direction. Do not offset around beams, columns, or other obstructions.
- 6) Use 45° Y-Branched or 90° Long Turn T-Y where two lines interconnect. Connections should not be made from the bottom.
- 7) Install all valves and check valves horizontally.
- 8) Cleanouts required in slurry lines only and must be installed at every 90° bend and every 60 feet maximum in straight pipe runs. Use 45° Y-Branch and 90° Long Turn T-Y for cleanouts (All Cleanouts Must Be Accessible).
- 9) Somat disposers require flexible connectors in slurry and return lines only.
- 10) Companion Flanges, Gaskets, and Hardware not supplied at pipe line terminations.
- 11) Keep drains accessible to unit. Do not install drains under Somat Equipment.
- 12) Piping must be supported and braced independently of Somat equipment.  
**ALL INTERCONNECTING PIPING MUST BE SUPPORTED SO THAT NO MOVEMENT OCCURS DURING OPERATION**
- 13) No external strain to be exerted on Somat equipment.
- 14) Protect all Somat equipment and piping from freezing acid condensation.
- 15) **ALL INTERCONNECTING PIPING MUST BE SUPPORTED SO THAT NO MOVEMENT OCCURS DURING OPERATION.**
- 16) "F" = furnished by Somat, "NF" = not furnished by Somat.

The following are some suggested forms of pipe bracing for a SOMAT waste handling system. There are many factors involved which require the additional bracing. This system in normal operation is subject to surges from air, water, and solids. If the piping is not properly supported and “works” during operation it will only be a matter of time before a failure occurs.

**If you have any questions or concerns, please call Somat Company and speak with the service or engineering departments to get clarification.**

1. Support horizontal piping and fittings at sufficiently close intervals to maintain alignment and prevent sagging or grade reversal. Support each length of pipe by an approved hanger located not more than 18 inches from the joint.
2. Support terminal ends of horizontal runs or branches and each change of direction or alignment with an approved hangar to prevent movement. Prevent movement in vertical, lateral, and axial directions.

#### **FRESH WATER:**

**Check local codes regarding the proper backflow prevention devices to be installed.**

- 1) Bring a 3/4" cold water line for the SP-75S, to the pre-piped fresh water assembly. (See enclosed diagram and Installation Drawings)
- 2) Bring a 1/2" hot water line to the pre-piped fresh water assembly on the Hydra-Extractor (see enclosed diagram and Installation Drawing).

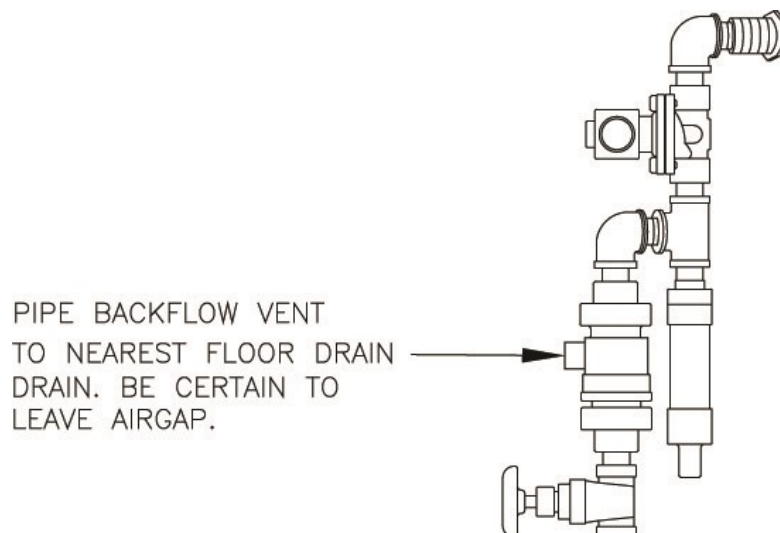

## SLURRY AND RETURN PIPING

- 1) Install the Pulper slurry pump piping assembly on to the slurry pump.  
(See Installation Drawings).
- 2) Install the Pulper return line piping assembly on to the pulper tank.  
(See Installation Drawings).

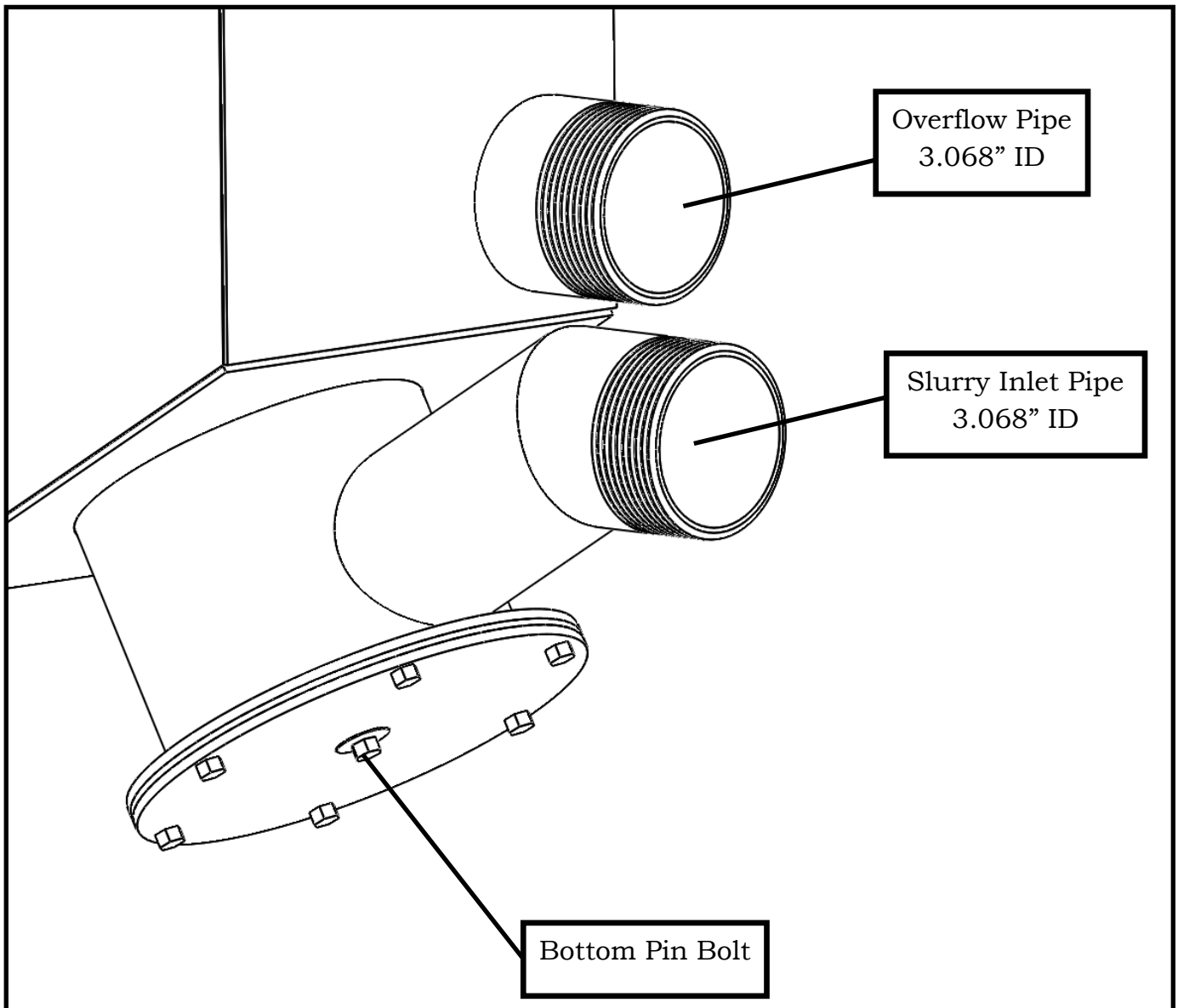

## RETURN PIPING FOR UNITS WITH A TROUGH:

Pipe the trough spreader plate and optional side nozzles and silver saver to the tee in the return line piping assembly as shown in the trough detail on the installation drawing using the provided throttling valves and trough nozzles.

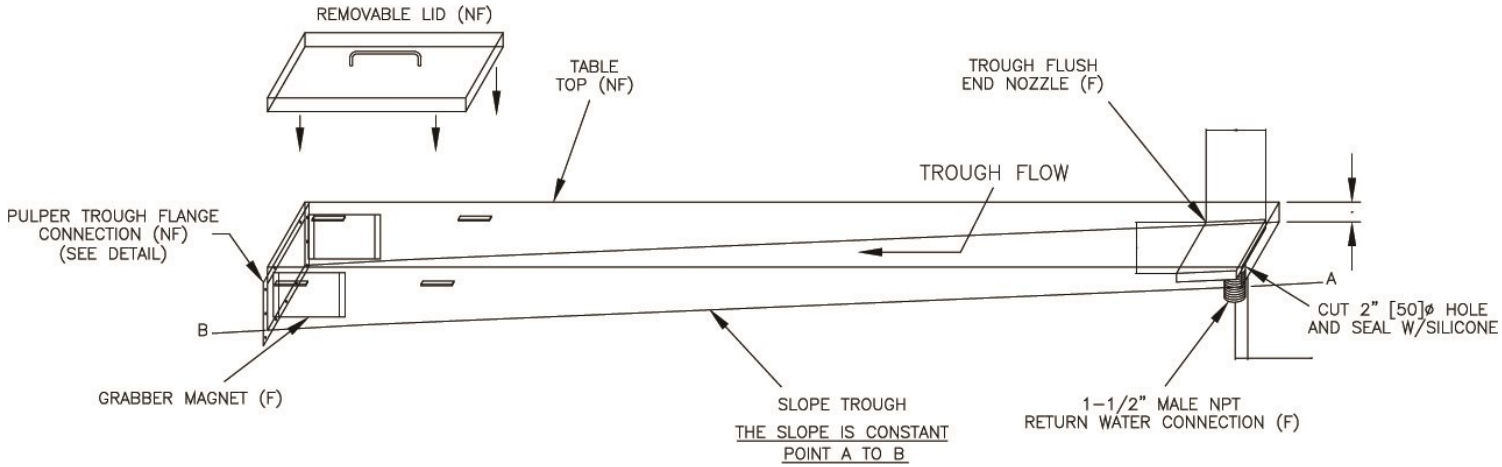

**NOTE: All Pre-Piped Assemblies are hand tightened for shipping purposes only.**

# ELECTRICAL INSTALLATION

1. Pre-wired control panels, operator devices & electric valves by Somat.
2. Install conduits from panel to prewired junction box, pull motor wires and control wires through separate conduit and do the final terminations.
3. Ground all electrical equipment.
4. Control circuit to be 115 VAC and/or 24VDC nominal. (See Approved Drawings)
5. All Som-A-Trol panels are to be wired in accordance to local, state and/or national electric code specifications.
6. Integral push buttons are located in panel door and pre-wired at factory. Optional remote push button station if supplied; to be mounted & wired at work station by electrician. (Bracket Required By Customer)

## PANEL & OPTIONAL REMOTE PBS MOUNTING:

- 1) Mount the Som-A-Trol® (electrical control panel) in a suitable location (see Installation Drawings) so that the bottom of the panel is at least 48" above the finished floor or in accordance with ADA requirements.
- 2) Install the Optional Remote Push Button Station onto the Dish Table or at another convenient location. (See Diagram and Installation Drawings.)

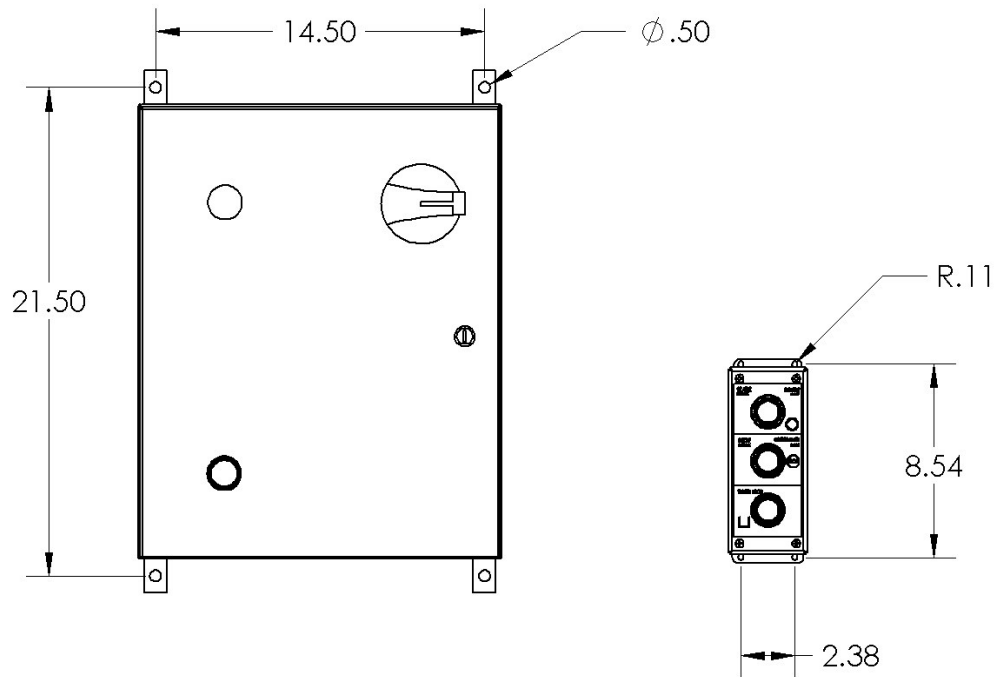

## MOUNTING PATTERN FOR THREE HOLE PUSH BUTTON STATIONS

## **SUPPLYING THE SOM-A-TROL® WITH POWER**

Bring the (4 wire) customer power supply to the top right side of the Som-A-Trol® and connect to the panel disconnect and ground lug. (See Diagram and Installation Drawings.)

All close couple systems are prewired; there is a prewired junction box mounted to the side of the extractor shell. Inside this prewired junction box there will be terminals that are the same as in the panel. Install conduits from the panel to the pre-wire junction box, pull the motor wires and control wires thru these conduits separately and do your final wire terminations matching numbers from panel to pre-wire junction box.

## **REMOTE PUSH BUTTON STATION**

Mount the remote push button station, run the conduit from the remote push button station to the prewired junction box then pull the wires from the remote push button station to the prewired junction box and do your final hookups in the prewired junction box.

## **INTERCONNECTING WIRES**

On the remote system there are interconnecting wires that go from the extractor panel to the pulper panel. To install, run a piece of conduit between the extractor panel and pulper panel. Pull control wires (as listed on the FE drawing) through from extractor panel to pulper panel and install the wires to the terminals which have the same numbers in both panels.

## **WARNING:**

Improper connection of the equipment grounding conductor can result in a risk of electrical shock. An equipment grounding conductor must be run with the circuit conductors and connected to the pulper/extractor grounding terminal.

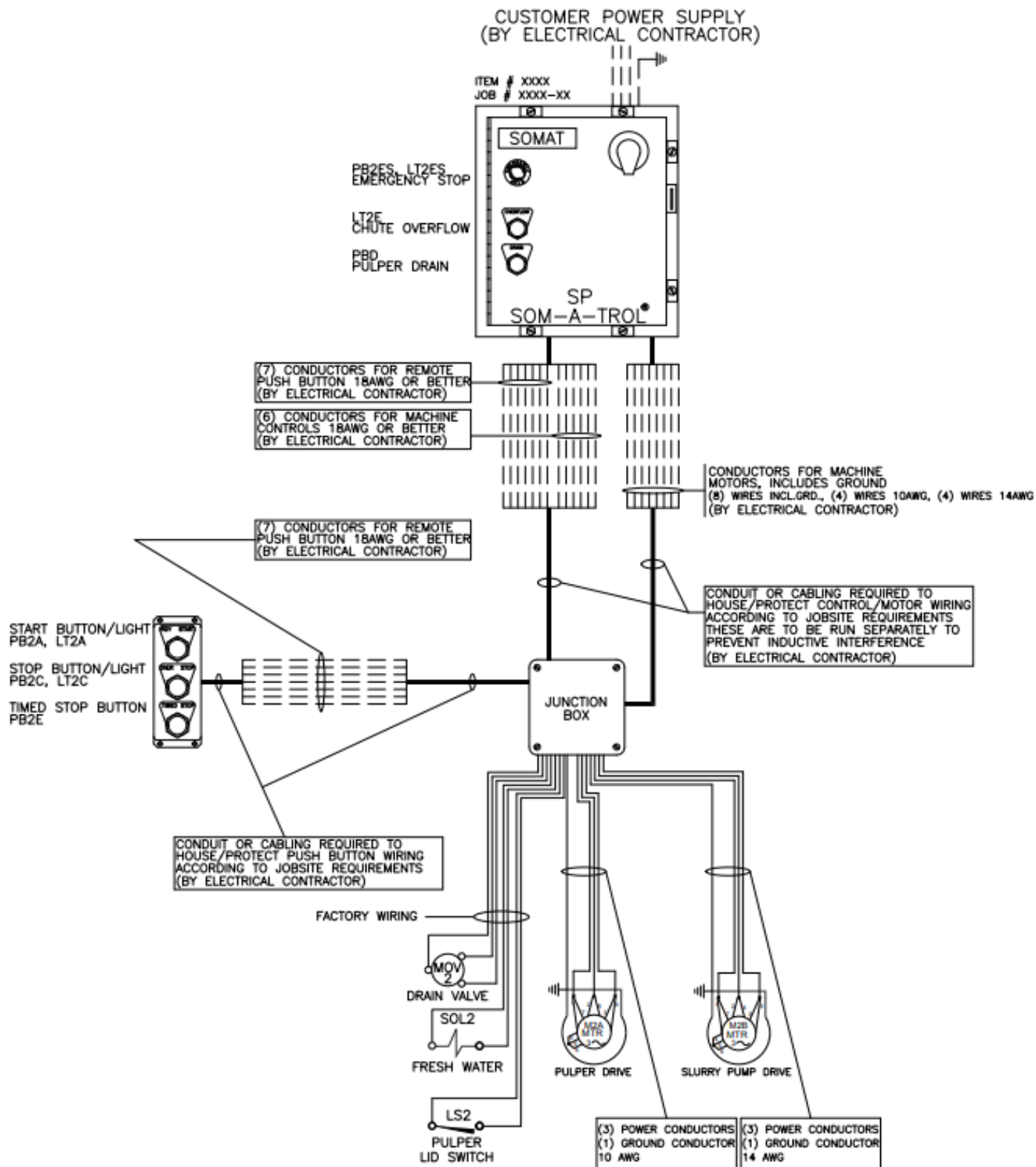

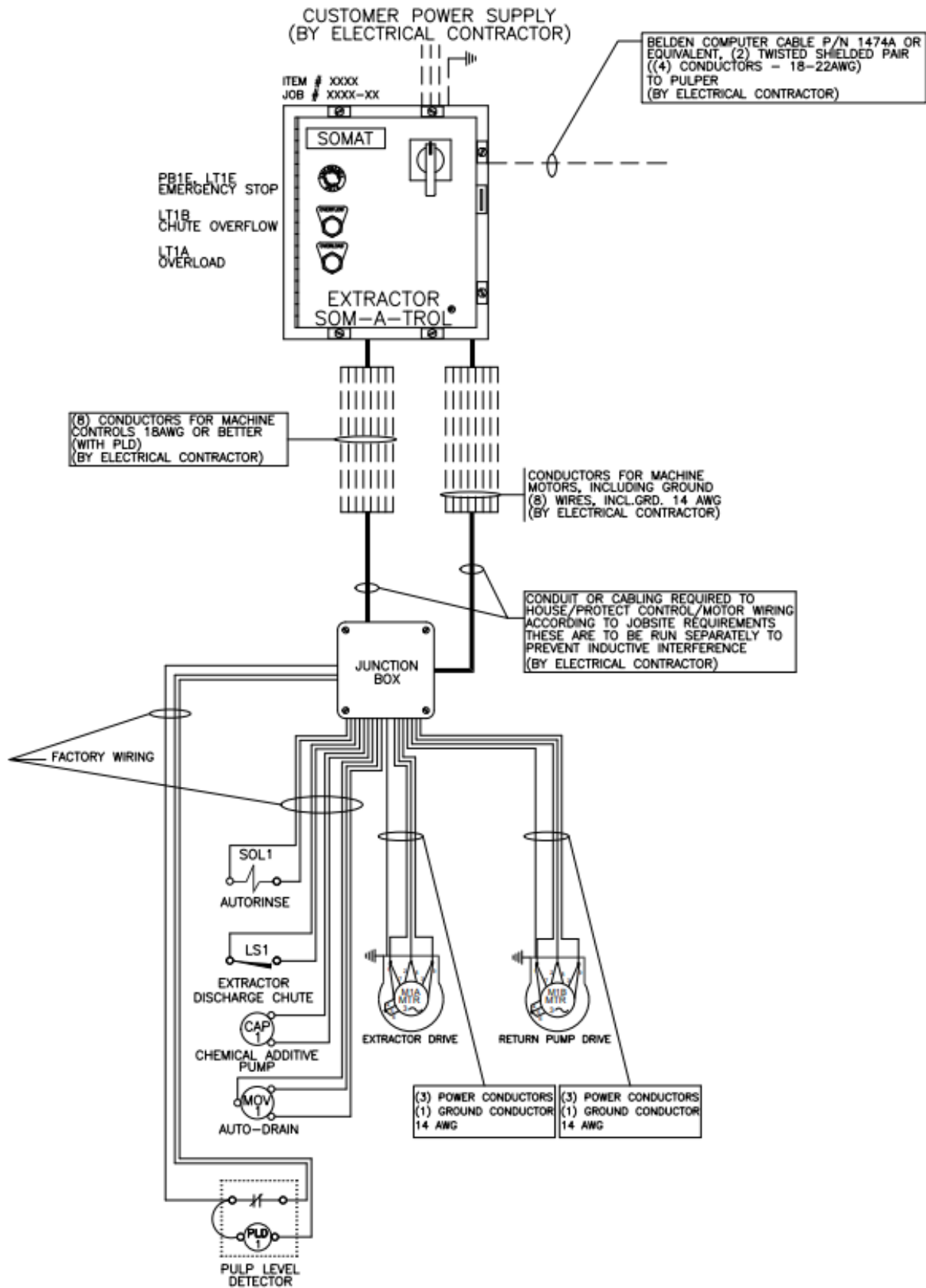

# **Start Up**

After installation is complete, call Somat Service **(800-237-6628 x176)** to schedule your machines start up. Your equipment will be started up by a qualified Somat service representative. This startup will get your unit running in accordance with Somat guidelines. The equipment may be demonstrated to you by the service company or a Somat Representative.

**SOMAT REQUIRES 2 WEEKS ADVANCE NOTICE OF  
START-UP FOR SCHEDULING PURPOSES.  
THANK YOU IN ADVANCE FOR YOUR UNDERSTANDING.**

### **EQUIPMENT STARTUP**

**New Equipment Startup:** Authorization from Somat Company is required before responding to startup requests. Third party initiations will not be accepted. Authorization will be in the form of a “Pre-Startup Checklist” which is sent from Somat.

**Startup Packages:** Startup packages contain pertinent information for the technician to perform a proper startup. These packages contain electrical and mechanical prints as well as the Operator/Install manual. This information must stay with the equipment.

**Installation Errors:** If technician finds equipment is not ready for startup due to installation errors or incomplete installation, the technician must notify Somat Company by calling Service & Support: (1-800-237-6628 ext: x176).

**Startup Billing:** Somat recognizes labor, mileage and travel for startup billing. Please include completed Somat Warranty Registration form and completed Startup Checklist, both of which are found in Startup Package paperwork.

**The Somat equipment carries a 1 year warranty from date of start up (see page 3). To accurately track this information, we ask that you fill out the Warranty Registration Sheet on the next page and email back to us. This will ensure your equipment is registered with Somat’s Service Department and will allow Somat’s Service Department to efficiently process a warranty claim if one should arise.**



**WARRANTY REGISTRATION FORM**

Serial #:	Model #: SP-75 & HE-6
-----------	-----------------------

Date of Start Up: \_\_\_\_/\_\_\_\_/\_\_\_\_

Customer Name: \_\_\_\_\_

Address: \_\_\_\_\_

City: \_\_\_\_\_ State: \_\_\_\_\_ Zip: \_\_\_\_\_

Contact Name: \_\_\_\_\_

Contact Number: \_\_\_\_\_ Email: \_\_\_\_\_

Service Company: \_\_\_\_\_

City: \_\_\_\_\_ State: \_\_\_\_\_ Zip: \_\_\_\_\_

Please email to:

Somat Company Service Department

717-291-0878 OR email to [service@somatcompany.com](mailto:service@somatcompany.com)

OR send with startup paperwork.

**WARRANTY REGISTRATION FORM**

# Operation

**TYPICAL STARTUP AND OPERATING PROCEDURE** - The following startup procedures must be followed prior to operating the System:

1. Check to ensure that the main power switch of the SOM-A-TROL® panels is in the "ON" position.
2. Push **GREEN** push button on SOM-A-TROL panel or remote pushbutton station to close drain if opened. If drain is open, you will see a slow **GREEN** flash to indicate the drain is open. Once pressed, the drain will automatically close and pre-fill the pulper tank.
3. The Pulper will begin to fill with water, this is indicated by a steady flashing **GREEN** light. When the water has reached the prescribed level as indicated by a solid **GREEN** light, press the Pulper **START** button and wait until there is a continuous flow of return water before feeding waste to the Pulper either manually or by starting waste down the flushed trough, if so equipped.

**WASTE FEEDING INSTRUCTIONS** - Best results are obtained if the Pulper is fed waste at a **UNIFORM RATE**. Under normal conditions, waste may be fed to the Pulper as long as a strong vortex is maintained in the tank. If waste is fed too fast the vortex will diminish to a point where it will no longer pull the material into the impeller for efficient grinding.

Don't "slug feed" the Pulper for short periods of time with excessive feeding. Overloading interferes with the grinding process and takes longer to dispose of a given quantity of waste than if the machine is fed at a **UNIFORM RATE**.

When shutting down the Pulper for short periods, it is not necessary to run the Pulper until all the waste has been pumped out of the tank. Run the Pulper for a few minutes to thin down the slurry and then shut off the machine.

## PULPER START/STOP INSTRUCTIONS

### TO PRE-FILL AND START PULPER:

- Turn power on at main control panel.
- Press **GREEN** button and unit will pre-fill
- Once **GREEN** light is lit solid, unit is ready to run.
- If unit does not pre-fill
  - Pull out on emergency stop
  - Ensure power is on
  
- Press **GREEN** start button to operate machine.

### TO STOP AND SHUTDOWN PULPER:

- To stop pulper, press **RED** stop button once.
- At end of day, press **BLACK** 'Timed Stop' pushbutton once.
- Wait until unit shuts down by itself.
- Press 'Drain' pushbutton on main panel door.
- Clean unit.

### TO START UNIT AFTER TIMED STOP:

Press **GREEN** pushbutton once and follow instructions from the top.



**SHUTDOWN PROCEDURES** - The following shutdown procedures must be followed prior to performing necessary cleaning and maintenance duties.

1. Allow the Pulper to operate approximately five minutes after the last waste has been fed.
2. Depress black "**TIMED STOP**" pushbutton once to engage spray rinse system, system will then time out on its own. The Pulper will stop when the shutdown timer has timed out.
3. Press "**DRAIN EMPTY**" pushbutton on panel door to drain system. This pushbutton will **DRAIN all water in the system.**
4. Turn power off to perform any cleaning or maintenance.
5. Refer to the applicable Pulper and Hydra-Extractor® maintenance sections of this manual for daily, weekly and long-term shutdown cleaning procedures and maintenance instructions.

## LIGHT CODES

SOMAT systems employ a micro-computer to control many of the unit functions. If a fault or overload is detected, the system will flash a series of codes by lights located either on the pushbutton station OR on the panel enclosure itself. Below is a list of the most commonly used for close coupled machines.



Solid **Green**: All safeties are latched and secure, system is ready to run

Flashing **Green**: System is in timed stop mode, extractor will spray, after less than 10 minutes system will shut down.

Slow flashing **Green**: Unit drain is open, press **Green** pushbutton to close drain.

Two **Green** flash, pause, and repeat: All safeties are latched and secure, tank is filling.

Solid **Red**: One of systems 3 motors is overloaded and must be reset

Flashing **Red**: Lid switch on pulper or extractor lid is open, shut lid to resume normal operation

Two **Red** Flash: Extractor chute is open

Three **Red** Flash: Extractor drive motor overload has tripped

Four **Red** Flash: Return pump motor overload has tripped

Five **Red** Flash: E-Stop at extractor has been pressed

Six **Red** Flash: Communication fault

**\*Consult Electrical Schematic in Som-A-Trol® Panel Door For Additional Flash Codes**

## **SPECIAL OPERATING CONDITIONS**

The following conditions could occur and should be watched for:

1. Overfeeding - The SOMAT® Pulper is designed as a continuous process machine. In general, the feed rate should not exceed one tenth of the rated hourly capacity in any six-minute period. Exceeding this will cause the machine to bog down and operate under its rated capacity.
2. Foaming - this is caused by contaminants in the water, or by certain materials in the waste, such as glue in corrugated cardboard and excessive starches. Add a SOMAT DE-FOAMER, or comparable commercial de-foamer
3. Freezing - All equipment and piping should be protected from freezing. Insulation and heating cable are often used where equipment is exposed.
4. Non-Pulpables - The SOMAT® Pulper is designed to handle a limited amount of non-pulpable material. The lighter items are eventually ground, and the heavier material is discharged into the junk box.

Occasionally, the amounts of non-pulpables may become excessive and the processing rate may begin to decrease. Safely stop the Pulper, scoop out the non-pulpable matter, and then re-start the Pulper.

**WEARABLE PARTS**, moving parts, and their mating surfaces, will wear during normal production. Routine maintenance and inspection will disclose which parts are wearing and provide an indication as to when replacement will be necessary. The maintenance plan should include pre-ordering of spare parts and scheduled replacement. Rotating blades may be re-sharpened. To remove blades please follow instructions located in the “Cutting Mechanism” section of this manual.

# **Cleaning Your System**

## CLEANING INSTRUCTIONS

After feeding waste to the SOMAT® System has been completed for the day, the equipment should be thoroughly cleaned. The cleaning operation requires only a few minutes daily and, if properly done, will keep the machine free of odor and at top-operating efficiency. A regular cleaning program will eliminate costly maintenance and unsatisfactory operation.

### CLEANING THE PULPER:

With the system properly shut down, in accordance with the System "Shutdown Procedures", perform the following:

1. Clean the Junk Box of non-pulpable material
2. **CAUTION BROKER GLASS MAY BE PRESENT IN THE PULPER**
3. Wash the interior of the pulper shell with a hose, suitable brush, detergent and deodorant or other cleaning solution. Exercise care in cleaning the underside of the upper shell flange. Wipe down the equipment exterior.
4. Leave lid open (if allowed) to let machine air out and reduce odors.

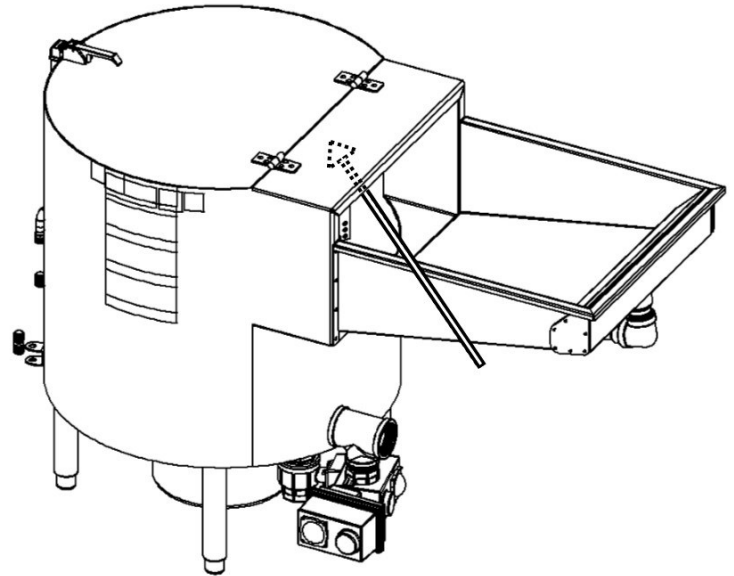

**Underside of Upper Shell Flange**

### CLEANING THE HYDRA-EXTRACTOR®:

1. With a high-pressure hose, wash down screens and interior walls of Hydra-Extractor® housing. If necessary, a long-handled brush can be used.
2. **Long Term Shut Down Procedure** - If the Pulper is to remain idle for a relatively long period (three weeks or more), special procedures should be taken to protect the equipment. These procedures are as follows:
  - a. Perform the daily cleaning procedure, and then circulate a solution of a cleaning and disinfecting agent through the lines to combat bacteria growth and odor.
3. Wash down screens and interior walls of Hydra-Extractor housing.
4. Leave lids open after draining to prevent mildew growth

**CLEANING TIP:** To ensure all food waste is removed from the extractor, you can use Styrofoam plates as a cleaning agent for the unit. The Styrofoam will force out most of the food waste leaving only Styrofoam at the top of the extractor screw. Run the plates as you would any waste and continue until nothing but Styrofoam exits the extractor. We do not recommend using cardboard as a cleaning agent as it will dry out and create a very hard obstruction in the extractor which could cause motor overload on restart.

## **CLEANING COMPOUNDS**

The ideal cleaning compounds available for use with SOMAT® equipment combine four important functions: detergency, disinfection, pH buffering and odor counter action.

In order to help our customers overcome the problem of selecting chemicals for use with their SOMAT® System, we offer the chemicals that we believe will best meet their needs.

### **SOMAT® NEUTRO PLUS (72000)**

Designed for use in the SOMAT® System to keep it clean, to deodorize, and to reduce grease build-up. This is an industrial strength product. The surfactants in this detergent/deodorant are bio-degradable.

### **SOMAT® DEFOAMER (73000)**

A neutral, liquid silicone emulsion specifically designed for suppressing and controlling Undesirable foam. This is an industrial strength product. The surfactants in this de-foamer are biodegradable. Dilution: Five (5) parts water to one (1) part de-foamer.

**Please direct all orders to Authorized SOMAT Parts Distributors. If you have questions, please feel free to contact us at [service@somatcompany.com](mailto:service@somatcompany.com)**

# **Maintenance**

## PERIODIC MAINTENANCE AND INSPECTION

These procedures consist primarily of regularly scheduled cleaning and inspections. The time intervals cited are based on normal use of the SOMAT® unit; approximately **six hours per day**, seven days per week. Equipment operating more than this or in severe service will require more frequent inspection/maintenance.

Cutting blades and grinding teeth will sustain the highest degree of wear. Continued adherence to these inspections will provide adequate lead time when ordering spare parts, thereby minimizing unnecessary and costly equipment downtime.

### PREVENTIVE MAINTENANCE INSPECTION SCHEDULE

PULPER	DAILY	WEEKLY	MONTHLY	QUARTERLY
<b>1. GENERAL</b>				
a. Check shell and slurry chamber for wear.			X	
b. Check exterior finish for corrosion.			X	
<b>2. IMPELLERS</b>				
a. Check impeller blades for wear.		X		
b. Check stationary blades for wear.		X		
c. Check impeller for wear.				X
d. Check security ring for wear.				X
<b>3. DRIVE</b>				
a. Check seal for leakage.	X			
b. Check bearings for noise and wear.				X
	DAILY	WEEKLY	MONTHLY	QUARTERLY
<b>1. GENERAL</b>				
a. Check cutting mechanism for non-pulpable object impact damage.	X			
b. Check bolts for tightness.		X		
c. Check stationary cutter block to impeller cutter ear clearance.			X	

EXTRACTOR		DAILY	WEEKLY	MONTHLY	QUARTERLY
<b>1. GENERAL</b>					
a. Check exterior finish for cor-					X
<b>2. EXTRACTING UNIT</b>					
a. Check screw and brush for					X
b. Check screen for wear.					X
<b>3. DRIVE</b>					
a. Check reducer for noise and				X	
b. Check bushing and bottom pin.					X
Lubrication Chart	FREQUENCY	TYPE OF FITTING		LUBRICANT	
Hydra-Extractor® speed reducer	6 months to 1 year	Oil fill plug		Amer. Worm Gear Oil (Amoco) Gear Oil 629 (Mobil)	

Return Pump		DAILY	WEEKLY	MONTHLY	QUARTERLY
<b>1. GENERAL</b>					
a. Check exterior finish for corrosion					X
b. Check pump casing for wear					X
c. Check impeller for wear					X
<b>2. DRIVE</b>					
a. Check seals for leakage		X			
b. Check bearings for noise and wear					X
c. Grease Bearings					X

**COMPONENT REMOVAL AND REPLACEMENT** - The following steps are required in the removal and replacement of major components, assemblies, or piece parts necessary for corrective action.

### **DRIVE MOTOR REMOVAL**

- After turning the circuit breaker off, remove cover on drive motor junction box and disconnect motor leads.
- Remove conduit from motor junction box.
- Remove the drive motor from the slurry chamber assembly by removing four machine screws.

### **MECHANICAL SEAL REMOVAL**

- Remove spring and upper seal ring prior to removing motor.
- With motor removed push upward on Ni-Resist Seal until it can be removed.

### **MECHANICAL SEAL INSTALLATION**

- Clean the seal cavity and moisten the O-ring of the Ni-Resist Seal with soapy water.
- Tap the Ni-Resist Seal in the cavity with seal installation tool (part number [89711](#)). The cut out on the face should be face down.
- Lubricate the upper seal ring and slip it over the drive shaft.
- Slide the retainer spring onto the shaft.

### **SECURITY RING REMOVAL**

- Remove mounting bolts and lift Security Ring Assembly out of machine.

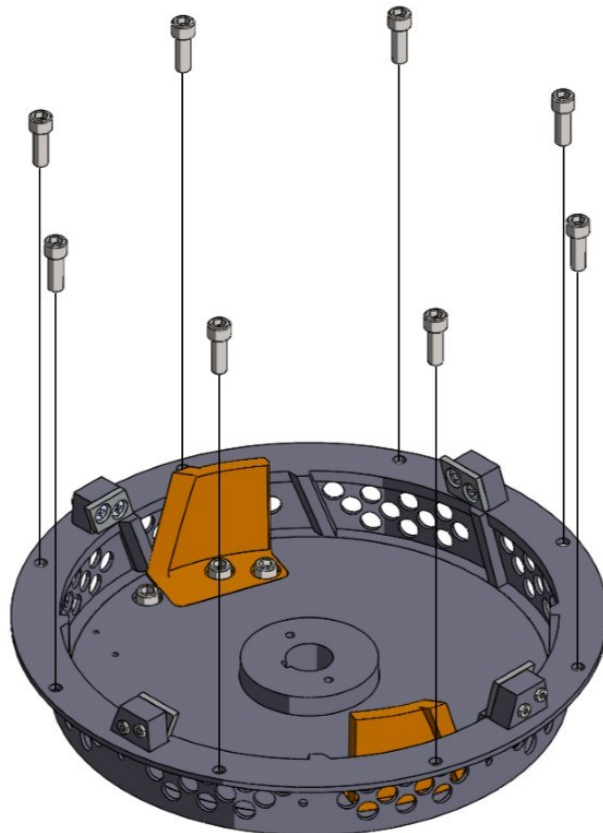

## REPLACEMENT OF SECURITY RING STATIONARY CUTTER BLOCK

- Remove stationary cutter block mounting screws and replace stationary cutter block. Shim if needed to a clearance of 0.005" to 0.010" between stationary blocks and rotating blades.

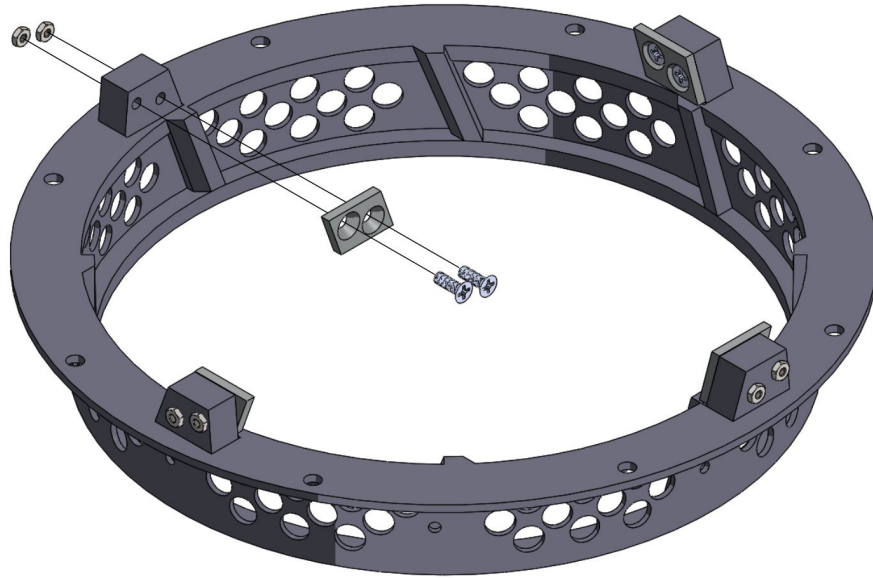

## IMPELLER REMOVAL

- Remove impeller hold down bolt (1) and washer (2) and carefully remove the impeller assembly from the motor drive shaft with an impeller puller (Somat P/N [84150](#)). To use Impeller Puller (3): Tighten the two fastening screws (4) to secure puller to impeller. Next, turn center setscrew (5) to lift impeller out of security ring. Remove key

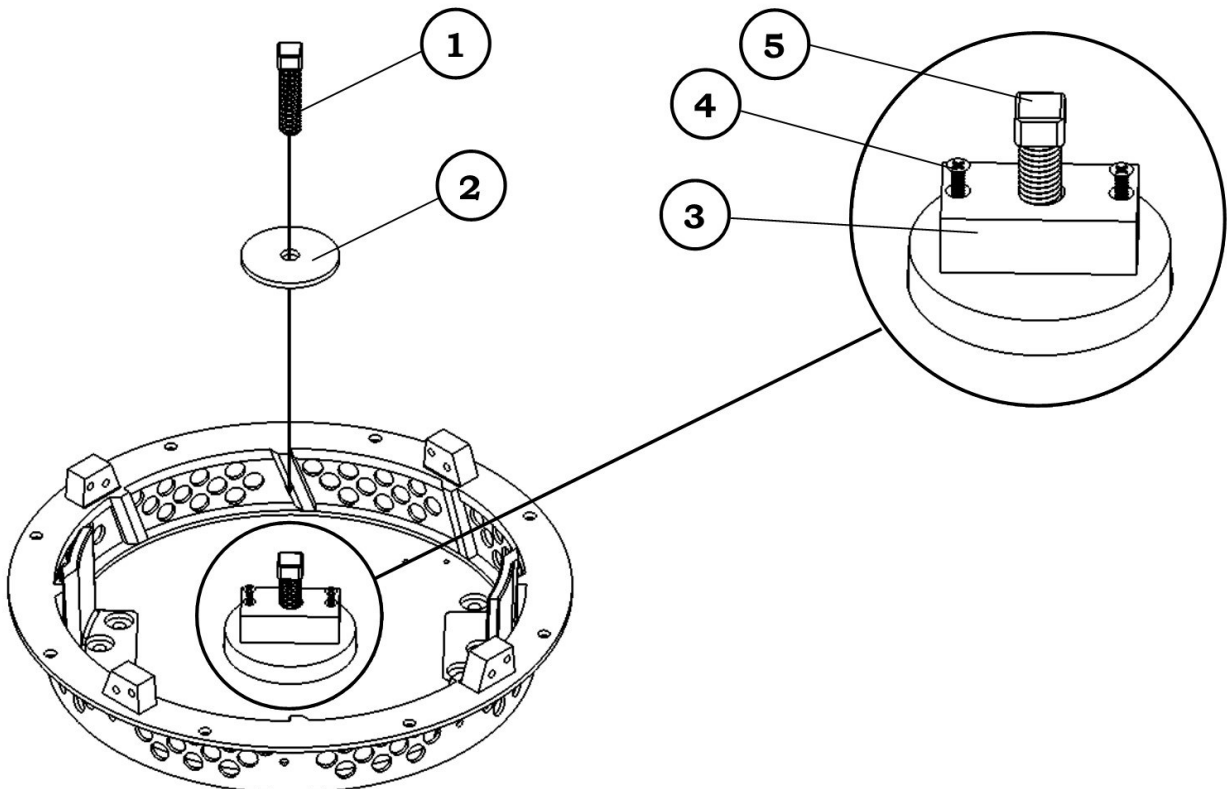

# ROTATING BLADES

## Replacement

- Remove two screws for the SP50 and three screws on the SP75 that hold impeller cutter ear to impeller.

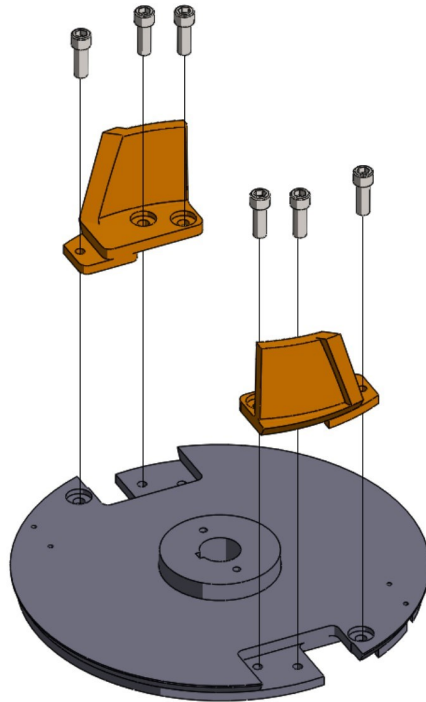

## Sharpening

- Rotating blades may be re-sharpened as cutting efficiency decreases. Remove impeller as described above. Remove attaching hardware for cutting ears. Using a gloved hand, firmly grasp blade and with an angle grinder, grind a new edge on interior of blade only. Interior of blade will face center bolt of impeller. The picture below has the edge to be resurfaced highlighted in black. DO NOT grind on opposing side of blade as this will reduce or impair any cutting ability.

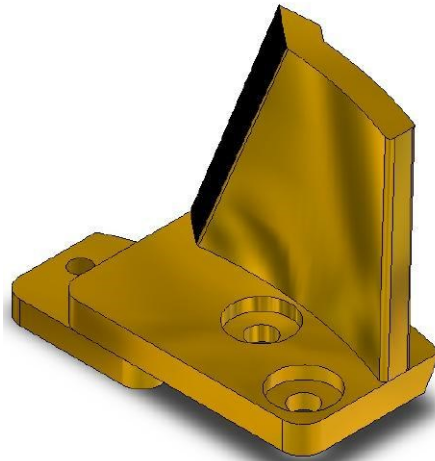

**Grind ONLY on area highlighted in black**

### EXTRACTOR DRIVE MOTOR REMOVAL

- After turning the circuit breaker off, remove cover on drive motor junction box and disconnect motor leads.
- Remove conduit from motor junction box.
- The drive motor (1) can be removed from the head assembly by removing four screws (2).

### EXTRACTOR SPEED REDUCER REMOVAL

- Remove bolt (3) and four machine screws (4).

### EXTRACTOR SCREEN AND SCREW REMOVAL

- After removing four machine screws (5), from head assembly (6) lift head with screen (7) and screw assembly (8) attached, from the Hydra-Extractor® shell (9).
- Remove the screw assembly from the screen assembly by pulling the screw assembly through the bottom opening of the screen, while turning bottom of screw counter-clockwise with a pipe wrench.
- After removing the screw assembly, remove two button head machine screws (10), from the screen and slip the screen from the head assembly.

### EXTRACTOR BOTTOM PIN REMOVAL

- Remove six machine screws (11).
- The bottom pin plate (12) with bottom pin (13) attached can now be removed.
- Remove screw (14). The bottom pin can now be separated from the bottom pin plate.

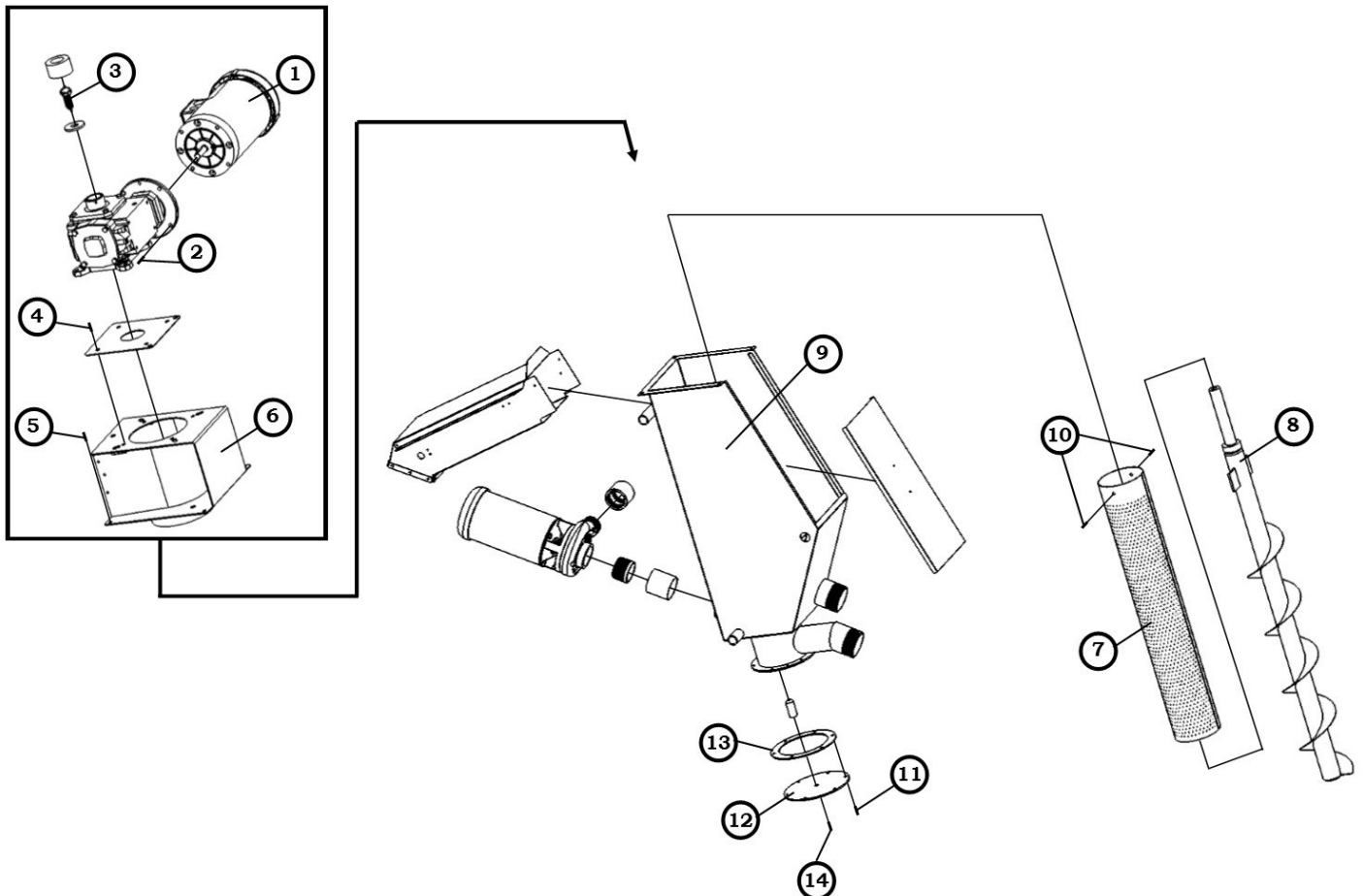

## **MP PUMP REMOVAL AND INSTALLATION OF MECHANICAL SEAL or MOTOR**

### **MECHANICAL SEAL:**

1. Turn off power and lock out machine
2. Remove (4) 5/16-18 hex nuts from Impeller housing
3. Remove housing from pump-pack assembly
4. The impeller will now be visible, take care to NOT place anything in impeller vanes. This will cause damage to the vane and will not be covered under warranty.
5. Loosen 2 bolts holding drive sleeve to motor shaft.
6. Remove impeller with drive sleeve as an assembly, mechanical seal should come off with drive sleeve.
7. Replace mechanical seal. Install with raised carbon face towards motor. Take care to install straight onto sleeve. Install ceramic disc into adapter seat bore with polished side up. Take extreme caution to not damage polished side as this will cause immediate leaks. Ensure seal is seated to bottom of adapter seat bore. If needed use a wooden dowel and gently tap into place to ensure tight seat into bore.
8. Replace impeller assembly back onto motor shaft. Use a light coating of anti-seize on motor shaft to ensure smooth seating.
9. Push down onto impeller head using a gloved hand to reach a gap of .030 between the bottom of impeller to top of adapter.
10. Tighten sleeve clamp while maintaining .030 clearance
11. Check rotation of impeller to ensure proper seating and gap clearance
12. If rotation and clearance are ok, then replace housing to adapter
13. Install (4) 5/16-18 nuts and lock-washers onto studs and tighten to 15-ft.lbs.
14. Verify that impeller does NOT hit or scrape housing.

## **MOTOR REPLACEMENT**

1. Turn off power and lock out machine.
2. Remove (4) 5-16-18 hex head nuts from impeller housing
3. Remove housing from pump-pak assembly
4. Loosen 2 bolts holding drive sleeve to motor shaft
5. Remove impeller with drive sleeve as an assembly, taking care not to damage mechanical seal or pumping vanes
6. Remove (4) 3/8 – 16 x 3/4 hex head screws from adapter plate to motor.
7. Remove adapter unit from motor.
8. Replace motor as required properly wiring unit. Ensure that wiring is for correct voltage
9. Replace pump-pak as described in MECHANICAL SEAL REMOVAL SECTION #'s 8-14

# Troubleshooting

SYMPTOM	POSSIBLE CAUSE	CORRECTIVE ACTION
<p><b>Not enough water in Pulper.</b></p>	<p><b>1. Water make up shut-off valve closed.</b></p>	<p><b>1. Open valve.</b></p>
	<p><b>2. Low water pressure</b></p>	<p><b>2. See “<i>Display Module Instructions</i>” to increase pre-fill and to increase frequency of make-up water</b></p>
	<p><b>3. Faulty operation of solenoid valve (see equipment schematic for location).</b></p>	<p><b>3. Check for loose electrical connections. If the valve plunger is stuck or the coil is burned out, replace with a new valve.</b></p>
<p><b>Too much water in Pulper.</b></p>	<p><b>1. Trough valve open too far</b></p>	<p><b>1. Throttle down valve to decrease water in pulper and increase water in extractor (more overflow)</b></p>
	<p><b>2. Misadjusted PLC POT setting.</b></p>	<p><b>2. The PLC controls the circuit to the solenoid valve. Too high a setting would tend to hold the solenoid valve open too long letting too much water into the Pulper. See “<i>Display Module Instructions</i>” to correct the problem.</b></p>
	<p><b>3. Faulty operation at valve. (see equipment schematic for location.)</b></p>	<p><b>3. Repair or replace solenoid valve.</b></p>
	<p><b>4. Overflow fitting and line clogged.</b></p>	<p><b>4. Clean fitting and line.</b></p>

<b>Pulper operates but pulping rate is low.</b>	<b>1. Plugging of sizing ring.</b>	<b>1. Check stationary blades and ears. If dull, replace. Refer to Pulper maintenance section. Check water level control - it may be adjusted too low. See previous section.</b>
	<b>2. Worn or missing impeller blades.</b>	<b>2. Refer to Pulper maintenance section for replacement procedure.</b>
	<b>3. Worn or missing stationary blades.</b>	<b>3. Adjust or replace blades in accordance with Pulper maintenance section of manual.</b>
	<b>4. Excessive foaming.</b>	<b>4. Add a de-foamer or any other suitable commercial preparation.</b>
	<b>5. Sluggish vortex due to:</b>	
		<b>a. See Previous section.</b>
	<b>b. Overload of waste.</b>	<b>b. Revise waste feeding rate (see Feeding Instructions, Section 4).</b>
<b>6. Clogged or worn pump.</b>	<b>6. See pump section for require corrective action.</b>	
<b>7. Clogged slurry lines.</b>	<b>7. Check individual cleanouts for loss of pressure to locate blockage. Remove blockage.</b>	

<b>Heavy flow from overflow pipe.</b>	<b>1. Excessive foaming</b>	<b>1. Add a de-foamer.</b>
	<b>2. Blockage of return line.</b>	<b>2. Check individual cleanouts to locate blockage.</b>
	<b>3. Improper Return water flow.</b>	<b>3. Readjust throttling valves.</b>
<b>Excessively wet pulp discharge from Hydra-Extractor®.</b>	<b>1. Blockage of screen.</b>	<b>1. Clean the Hydra-Extractor screen. Refer to Hydra-Extractor Maintenance Section of the manual.</b>
	<b>2. Worn screw and brush.</b>	<b>2. Remove and replace. Refer to Hydra-Extractor Maintenance Section of this manual.</b>

# **Display Module Instructions**

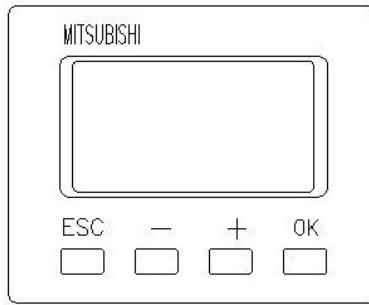

The set points for the Close Coupled pulper system are as follows:

- D0 – Pulper water initial fill duration (seconds). 0-1,200 second span
- D1 – Pulper makeup water during operation (seconds). 0-30 second span.
- D2 – Timed Stop duration (seconds). 0-1,200 second span
- D3 – Return Pump Start Delay (seconds) IF APPLICABLE. 0-20 second span
- D4 – Auxiliary Fill Duration (Optional with auxiliary pump) IF APPLICABLE.
- D5 – Pulper Hours of Operation.
- D6 – Pulper Minutes of Operation.
- D7 – Pulper seconds of Operation (displayed in 1/10ths of seconds).

The set points for the Remote pulper system are as follows:

FOR THE PULPER:

- D10 – Pulper water initial Fill Duration (seconds). 0-1,200 second span
- D11 – Pulper makeup water during operation. 0-30 second span.
- D12 – Pulper timed stop set point in seconds (1,200 seconds max).
- D13 – Pulper slurry pump start delay in seconds (20 seconds max).
- D14 – Auxiliary Fill Duration (Optional with auxiliary pump) IF APPLICABLE
- D15 – Pulper hours of operation.
- D16 – Pulper minutes of operation.

FOR THE EXTRACTOR:

- D100 – Extractor Off Delay and Rinse Duration during Off Delay(seconds). 0-1,200 second span
- D101 – Extractor Startup Rinse Duration after a Timed Stop Drain. 0-1,200 second span.
- D102 – Extractor hours of operation.
- D104 – Extractor minutes of operation.
- D106 – Extractor seconds of operation.
- D110 – Return Pump hours of operation.
- D112 – Return Pump minutes of operation.
- D114 – Return Pump seconds of operation.

The following tables are to be used for the SP-60, SPC-60, SP-75, and the SPC-75.

### SP/SPC-60 Water Control Module Settings

Fill Time (seconds)	Makeup Water (seconds per 30 seconds)
50 to 80	4
80 to 120	6
120 to 160	8
160 to 200	10
200 to 240	12

**Factory settings: D0 – 120 seconds, D1 – 6 seconds**

### SP/SPC-75 Water Control Module Settings

Fill Time (seconds)	Makeup Water (seconds per 30 seconds)
60 to 70	2
70 to 100	3
100 to 130	4
130 to 160	5
160 to 190	6
190 to 220	7
220 to 250	8

**Factory settings: D0 – 120 seconds, D1 – 4 seconds**

# STARTUP GUIDELINES FOR UNITS EQUIPPED WITH A DM MODULE

1. Follow normal startup procedure in regards to Electrical Check, General Installation Check, Plumbing Installation Check as noted on the Startup Checklist.
2. Mark the inside of the tank for fill line using a marker. **SP/SPC-75 is 7” and the SP/SPC-60 is 11”.** **If the machine is marked SP, i.e. SP75S, then it is a remote machine, if it is marked SPC, i.e. SPC75S, then it is a close couple machine.**
3. Fill the pulper. Once the pulper has stopped filling, press the Green Start button. Allow the unit to run for 30-60 seconds.
4. Press Stop pushbutton.
5. Press Drain pushbutton.
6. With a watch or timer, press the Green pushbutton once and time the water level to the fill line.
7. Using the seconds that it took to fill to the line, use the tables above to find the primary set-points.
8. To Begin using the DM Module, the power must be on to the PLC. If the date/time is displayed on the DM Module, then you are ready to proceed. If not, push the “ESC” button to display the date/time. Then, press the “OK” button twice to display the “D” register(s). From the Date/Time screen, after pushing the “OK” button twice, the DM Module will go to the last “D” register that was modified. The “D” number is displayed on the bottom of the DM Module screen. The value of that “D” number is on the right hand side of the screen. If you are on “D” with a zero on the bottom of the screen, you are in “D0”. To change prefill time (D0 for close couple and D10 for a remote machine) press OK once (enter value found in table above) and the value on the right side of the screen will flash. Push the “+” value to increase the value and the “-“ button to decrease the value. Once the value is the desired value, press “OK”. To go to D1 for a close couple machine and D11 for remote machines, press the “+” button once, if D2, press the “+” button twice, for instance. (For Remote machines this is D12).
9. To change duration time (D1 for close couple/D11 for remote machines) press OK once, then “+” or “-“ to change value and then press “OK” (enter value found in table above). To go to D3(D13 for remote machines) press the “+” button once, if D4 (D14 for remote machines), press the “+” button twice.
- 10.To change the Timed Stop Duration (D3 for close couple machines/D13 for remote machines) press OK once, then + + (enter value found in table above).
- 11.To verify all changes, drain the pulper and follow restart procedure. Verify how many seconds the fresh water solenoid remains on while the pulper is in operation.

**\*This information is for the service agency only. This information is not for customer use. If the customer has questions, please refer them to the factory.**