

INSTALLATION & OPERATION MANUAL

STERO ER SERIES CONVEYOR-TYPE DISHWASHER

MODELS:

ER44

ER76S

ER86S

ER54

ER76SC

ER94S

ER66S

ER64

ER94SC



ER44



STERO, a division of Illinois Tool Works, Inc. 165 Independence Court Lancaster, PA 17601
Phone: 800-762-7600 **Fax:** 707-762-5036 **Website:** Stero.com

IMPORTANT FOR YOUR SAFETY

ONLY QUALIFIED PERSONNEL SHOULD PERFORM THE INITIAL FIELD STARTUP AND ADJUSTMENTS OF THE EQUIPMENT COVERED BY THIS MANUAL.

READ THIS MANUAL THOROUGHLY BEFORE OPERATING, INSTALLING OR PERFORMING MAINTENANCE ON THE EQUIPMENT.

⚠ WARNING Improper installation, adjustment, alteration, service or maintenance can cause property damage, injury or death.

FOR YOUR SAFETY

Do not store or use gasoline or other flammable vapors or liquids in the vicinity of this or any other appliance.

⚠ WARNING SHUT OFF THE STEAM BEFORE SERVICING THE UNIT.

⚠ WARNING Disconnect the electrical power to the machine and follow Lockout/Tagout procedures. There may be multiple circuits. Be sure all circuits are disconnected.

⚠ WARNING Electrical and grounding connections must comply with the applicable portions of the National Electric Code and/or other local electrical codes.

⚠ WARNING UL73 grounding instructions: This appliance must be connected to a grounded, metal, permanent wiring system; or an equipment-grounding conductor must be run with the circuit conductors and connected to the equipment-grounding terminal or lead on the appliance.

**IN THE EVENT OF A POWER FAILURE,
DO NOT ATTEMPT TO OPERATE THIS DEVICE.**

TABLE OF CONTENTS

START-UP CHECKLIST	4	Fill Button	11
GENERAL	5	Heat Button.....	12
Introduction	5	Start Button.....	12
Location of Data Plate	5	Stop Button	12
INSTALLATION	6	(Optional) Booster Heat Button	12
Codes and Standards.....	6	Run Cycle.....	12
Uncrating.....	6	Push Button Control Panel.....	12
Leveling	6	Shutdown.....	13
Load/Unload Table Attachment.....	7	Daily Shutdown.....	13
Curtain Installation	8	Extended Shutdown.....	13
Ventilation Duct Connection (if required)	8	MAINTENANCE	14
Electrical Connections	8	Parts Removal	14
Utility Connections.....	9	Scrapper Spray Manifold Removal	14
Plumbing Connections.....	9	Tree-Type Spray Manifold Removal.....	14
Water Supply Connections.....	9	Curtain Removal	15
Drain Connections.....	9	Strainer Pans Removal	15
Steam Connections.....	9	Cleaning.....	16
Electrical Connections.....	10	Interior	16
Electrical Lockout/Tagout Procedures	10	Spray Manifolds (Tree-Type and Scrapper)	16
Main Electrical Supply Connection	10	Curtains	16
Detergent & Rinse Aid Supply Connections	10	Exterior.....	17
OPERATION	11	Stainless Steel Care.....	17
Operating Controls Location	11	Cleaning	17
Push Button Control Panel	11	Preserving & Restoring	17
Temperature Gauges	11	Deliming	17
Operating Controls Function	11	TROUBLESHOOTING	18
Push Button Control Panel	11	PRODUCT SUPPORT & SERVICE	19
Safety Switch	11	STERO WARRANTY	20

START-UP CHECKLIST

BEFORE POWER IS APPLIED

- 1. Check all utility service connections for tightness (electric, hot water and drain(s)).
- 2. Verify drain is connected with air gap (per your local code) and properly draining.
- 3. Check for any loose hardware.
- 4. Check door to table for interference.
- 5. Check free rotation of wash/rinse arms.
- 6. Check to see that all strainer pans, buckets, and screens are in place.

AFTER POWER IS APPLIED AND WATER TURNED ON

- 1. Verify water supply is connected properly and not leaking.
- 2. Verify correct supply voltage and phase to machine and confirm with data plate ratings.
- 3. Close door and allow machine to fill completely.
- 4. Allow wash tank to achieve proper operating temperature.

RUN A 1 MINUTE CYCLE

- 1. Check operation of door interlock switch.
- 2. Check for proper pump motor operation and check for leaks.
- 3. Check for proper tank temperatures with pumps on and off.
- 4. Check wash tank for proper water level during start up and operation.
- 5. Verify final rinse temperature.

REINSTALL ANY PANELS REMOVED

GENERAL

INTRODUCTION

Every Stero product is built with the highest quality components that have established Stero's reputation as the food service industry's warewashing authority.

Stero Rack Conveyor washers move racked dishes by a pawl. Pawl action uses a single bar to pull the racks through the dishwasher. The dish rack is conveyed through a spray pattern directed from upper and lower stationary spray arms at a prescribed GPM flow rate. After the rack has passed through the wash spray, it moves on to activate the fresh-water final rinse.

Automatic warewashers contain heaters that maintain the proper water temperature in the dishwasher tanks. These heaters use electricity or steam. As a general rule, heaters maintain a tank temperature of 160°F (71°C) to ensure sanitation. Hot water sanitizing warewashing dishwashers use a booster heater to raise the incoming, general purpose hot water to at least 180°F (82°C) for the final sanitizing rinse.

The NSF requires an established amount of heat content to ensure sanitation. The water pressure for this cycle must be 20 PSI.

LOCATION OF DATA PLATE

The data plate (Figure 1) is located either on the front or on the side of the Main Electrical Control Panel. This data plate contains important information, including the dishwasher model and serial number.

Always have the model and serial number before calling for parts or service.

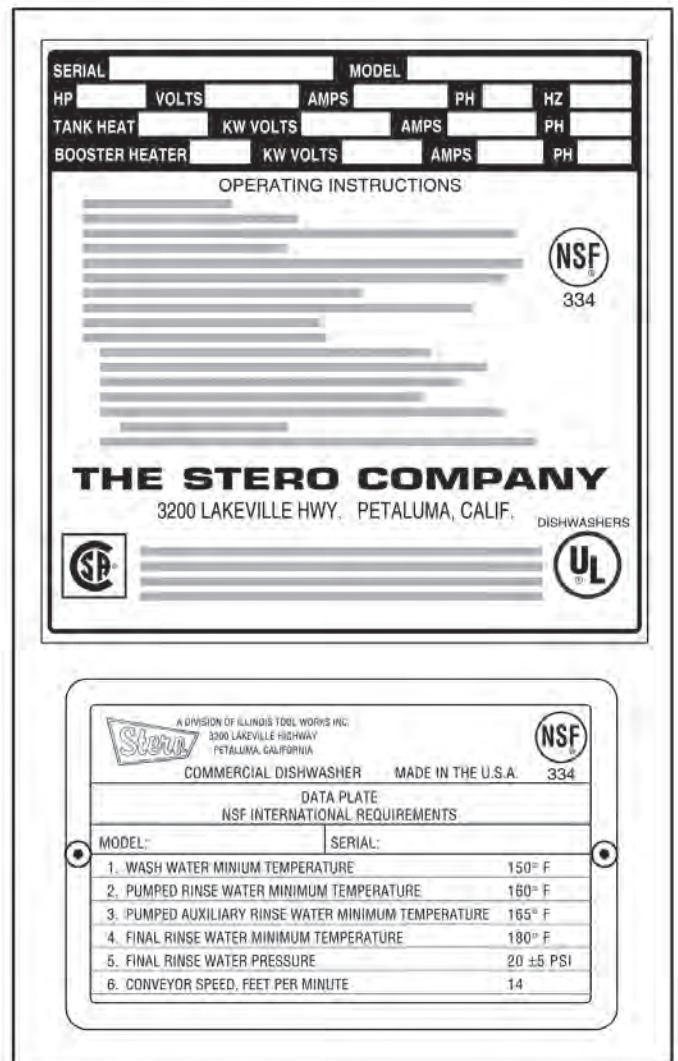

INSTALLATION

CODES AND STANDARDS

In the United States, the dishwasher must be installed in accordance with:

- State and local codes
- National Fire Protection Association, NFPA 54 (latest edition)
- Underwriters Laboratories standard UL 921, Commercial Dishwashers (latest edition)
- National Electrical Code NEC/NFPA 70 (latest edition)

In Canada:

- Local codes
- Canadian Electrical Code Part 1 CSA C22.1 (latest edition)
- CAN/CSA-C22.2 Number 168, Commercial Dishwashing Machines (latest edition)

UNCRATING

NOTE: As the equipment is unpacked, check that all components shown on the shipping invoice are present. Be sure to check for shipping damage. If shipping damage is present, contact Stero Customer Service at 1-800-762-7600 and provide customer details, dishwasher serial number and the extent of damage. Stero will file a freight claim based on this information.

⚠ WARNING Unless authorized by Stero Customer Service or its authorized agent, a damaged unit should not be installed or operated.

To uncrate the dishwasher, perform the following:

1. Remove all shipping and packaging material from the dishwasher, including supports and wrappings. Leave the shipping skid in place to allow for easier movement to the installation location.
2. Check for shipping damage as described above.

NOTICE The pallet should not be removed until the dishwasher has been moved to its installation area. Damage can occur from improper lifting and uneven weight distribution.

NOTICE Do not attempt to slide the dishwasher on its feet. This can bend the legs.

3. Move the dishwasher to the installation area and remove the skid. Use caution to avoid damaging the dishwasher or its components.

LEVELING

For proper operation, the dishwasher must be level. To level the dishwasher:

1. Using a bubble level, check that the dishwasher is level from both front to back and left to right.
2. Screw the feet in or out until unit is level both front to back and left to right.

INSTALLATION (continued)

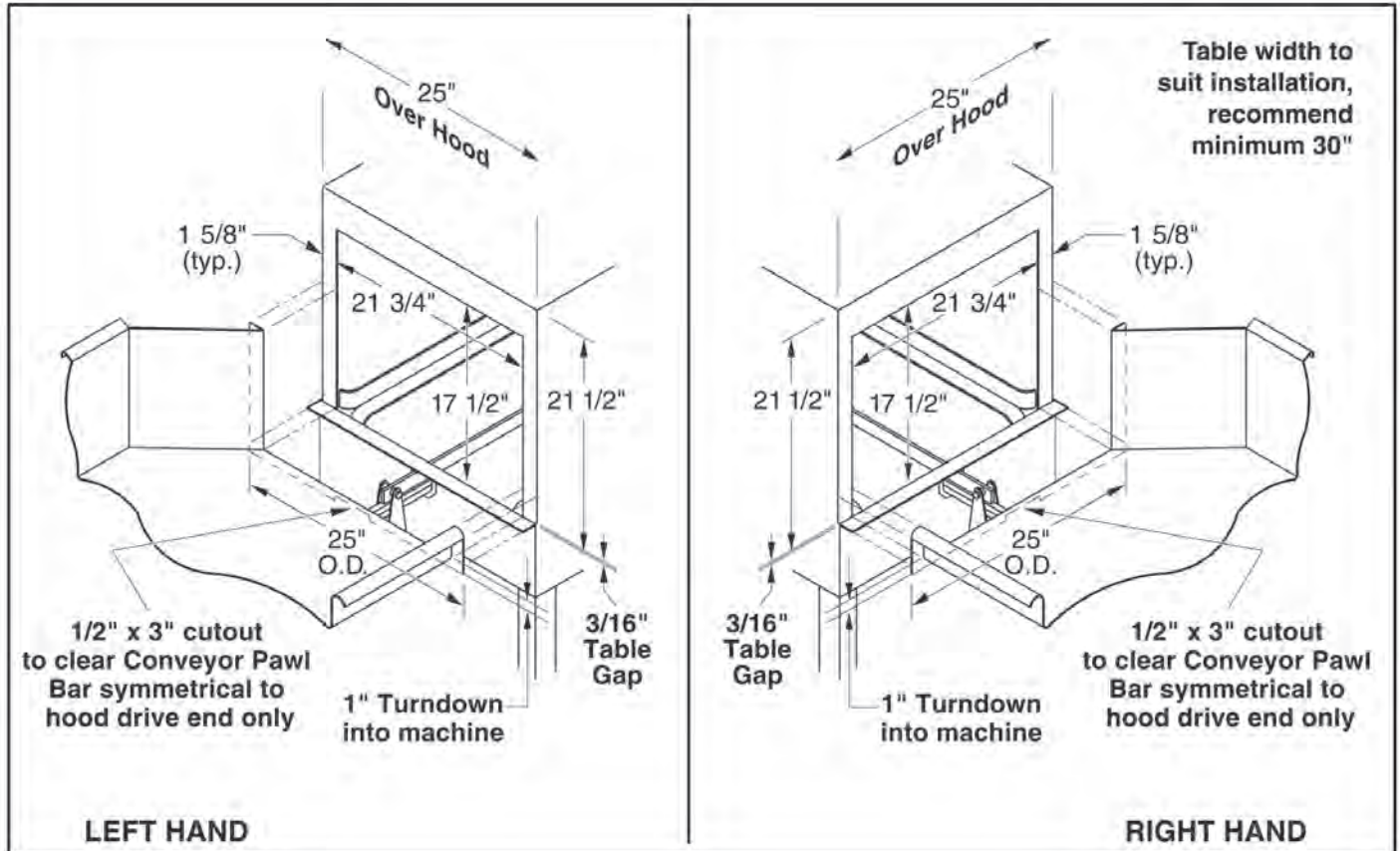

Figure 2

LOAD/UNLOAD TABLE ATTACHMENT

To properly attach the Load/Unload dish tables, perform the following:

1. Position the table lip or turndown at both ends of the dishwasher. Make sure to seat the lip or turndown into the dishwasher as illustrated in Figure 2.
2. Check that the centerline at the attaching end of each table is aligned with the centerline of the Pawl Bar on the dishwasher.
3. Using Figure 2 as a guide, mark the lip or turndown of the dish table for the required cutout to clear the Pawl Bar.
4. CAREFULLY cut the lip or turndown as illustrated in Figure 2. Deburr all sharp edges before reinstalling.
5. Reinstall the dish table on the dishwasher and check the cutout for proper clearance.
6. Adjust as necessary before proceeding.
7. Check that the surface height of the table matches the height of the dishwasher.
8. Apply an NSF-approved silicone sealant to the table's dishwasher mating surface, and securely attach it to the dishwasher with screws or rivets.
9. Ensure that the dishwasher is still level from front to back and left to right. Adjust the bullet feet as required to level the dishwasher.
10. Repeat the procedure to install the remaining dish table.
11. When both dish tables have connected, verify the dishwasher is still level.

INSTALLATION *(continued)*

CURTAIN INSTALLATION

Multi-flap curtains are used throughout the dishwasher to keep moisture inside and reduce the potential of hot water injury. The curtain configurations vary by model and size. Refer to the curtain placement decals located on the front of the main dishwasher hood for the exact curtain number and placement. Installation procedures are the same for all curtains.

1. Starting with the long, middle curtain, reach inside the main dishwasher compartment and locate the middle curtain rod holder.
2. Place one end of the curtain rod into its holder.
3. Place the other end of the curtain rod into its holder.
4. Repeat the procedure for the remaining curtains.

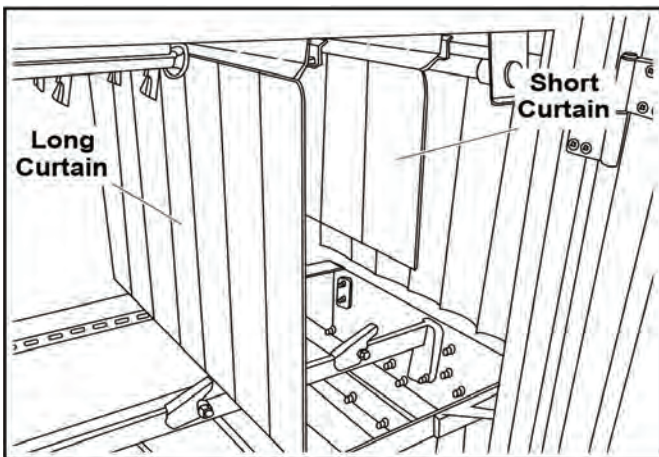

Figure 3

VENTILATION DUCT CONNECTION (IF REQUIRED)

For units that do not require ventilation duct connections, proceed to the UTILITY CONNECTIONS section.

Steam or Electric-Heated Dishwashers

For all other units requiring ventilation duct connections, proceed as follows:

1. Check that the ventilation ducts are correctly positioned above the dishwasher vents.
2. Refer to the Stero Engineering Drawing for the dishwasher ventilation requirements. This drawing is located in the Main Electrical Control Panel.

NOTE: Ducts should fit inside the dishwasher vents but not interfere with the operation of the dampers.

3. Install the ventilation ducts to the dishwasher vents per the dishwasher duct requirements and per local and state codes.
4. Seal the duct connection joint with silicone sealant.

ELECTRICAL CONNECTIONS

The exhaust fan is connected to an electrical box located on the back of the Main Electrical Control Panel, labeled as FAN CONTACTOR ENCLOSED (Figure 4). Connect the electrical connections as follows:

1. Remove the two (2) screws securing the Fan Contactor cover plate. Retain for reinstallation.
2. Remove and discard the 1/2" neoprene plug from the hole in the top of the Fan Contactor box.
3. Install a 1/2" sealtite connector to the exposed hole in the top of the Fan Contactor box.
4. Route the incoming electrical wires through the sealtite connector.
5. Connect the incoming fan electrical wires to the fan terminal block.
6. Reinstall the cover screws removed from step 1.

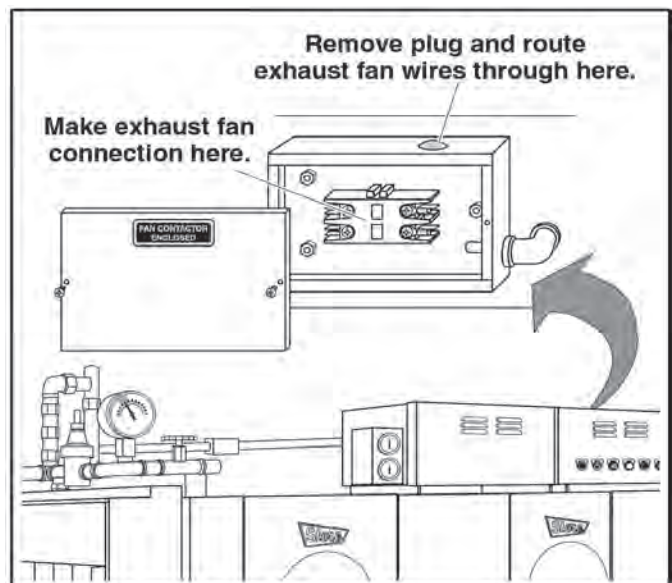

Figure 4

INSTALLATION *(continued)*

UTILITY CONNECTIONS

PLUMBING CONNECTIONS

Water Supply Connections

NOTICE Before connecting the water supply, it must be purged to remove any contaminants from the line.

NOTE: Ensure that the line strainer is installed so that iron or other metal particles cannot contaminate the dishwasher.

Refer to the Stero Engineering Drawing to connect the water supply to the dishwasher connection(s) as indicated by the connection labels attached to the connection points.

Proceed as follows:

1. Locate the water supply connection(s) as labeled on the dishwasher.
2. Check the incoming water temperature.
3. Connect the customer-supplied water line(s) to the appropriate connection(s).

NOTE: The dishwasher requires a pressure of 20 psi at the Final Rinse for correct operation (Figure 5). It may be necessary to increase the pressure (with a booster pump) or decrease the pressure (with a pressure reducing valve).

4. Check the incoming water pressure at the Final Rinse Pressure Gauge.



Figure 5

Drain Connections

NOTE: Make as many clean outs as possible in the drain line, using tees with pipe plugs in each tee instead of elbows, to allow the lines to be cleaned out periodically.

Refer to the Stero Engineering Drawing for the dishwasher drain requirements.

NOTE: In some cases, a grease trap must be fitted into the waste water line. If a grease trap is required for installation, check that it is present.

Install the Waste Drain per local and state codes.

Steam Connections

NOTE: Before connecting the steam supply, it must be purged to remove any contaminants from the line.

Refer to the Stero Engineering Drawing to connect the steam supply and condensate return to the dishwasher connection(s) requirements as indicated by the connection labels attached to the dishwasher connection points. Proceed as follows:

NOTE: Condensate return should be gravity fed back to the boiler. A return with an upward slope will require individual condensation removal systems.

1. Check that the incoming steam pressure is of sufficient pressure to meet the dishwasher pressure requirements per the Stero Engineering Drawing.
2. Check that the pipe size is equal to or greater than the dishwasher than the dishwasher requirements per the Stero Engineering Drawing.
3. When the correct pressure and volume have been verified, connect the customersupplied steam line(s) to the dishwasher steam connection(s) as indicated by the labels attached to the dishwasher connection(s).

INSTALLATION *(continued)*

ELECTRICAL CONNECTIONS

⚠ WARNING Electrical connections should be performed only by a certified professional.

⚠ WARNING Electrical and grounding connections must comply with the applicable portions of the National Electric Code and/or other local electrical codes.

⚠ WARNING UL73 grounding instructions: This appliance must be connected to a grounded, metal, permanent wiring system; or an equipment-grounding conductor must be run with the circuit conductors and connected to the equipment-grounding terminal or lead on the appliance.

⚠ WARNING Disconnect the electrical power to the machine and follow Lockout/Tagout procedures.

Electrical Lockout/Tagout Procedures

Lockout/Tagout procedures are used to protect personnel working on an electrical appliance. Perform the following steps when performing any type of maintenance or service on an electrically operated appliance.

1. Lockout the supply circuit breaker to the dishwasher.
2. Place a lock or other device on electrical box cover to prevent someone from placing circuit breaker ON.
3. Place a tag on electrical box cover to indicate that unit has been disconnected for service and power should not be restored until tag is removed by maintenance personnel.

Main Electrical Supply Connection

Refer to the Stereo Engineering Drawing and wiring diagram located inside the Main Electrical Control Panel for the dishwasher electrical supply requirements.

To connect the main electrical supply, proceed as follows:

1. Perform the ELECTRICAL LOCKOUT/TAGOUT procedures.

NOTE: Amperage and minimum supply wire specifications are shown on the wiring diagram located in the Main Electrical Control Panel.

2. Check that the incoming power leads are of sufficient rating for the dishwasher current draw.
3. Using the Stereo Engineering Drawing and wiring diagram for reference, install the power lines to the incoming power terminals.
4. Connect the ground wire to the ground terminal marked GRD.

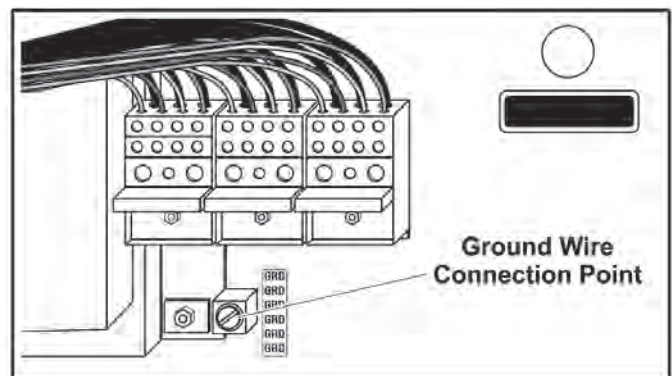

Figure 6

DETERGENT & RINSE AID SUPPLY CONNECTIONS

Once the dishwasher has been installed and all utility, electrical, plumbing and ventilation connections have been made, connect the chemical supply connections to the junction box located on the rear or side of the Main Electrical Control Box.

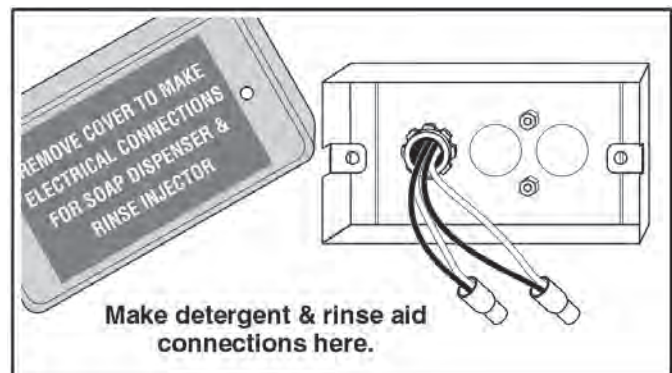

Figure 7

OPERATION

OPERATING CONTROLS LOCATION

The operating controls for the dishwasher are located in a stainless steel Main Electrical Control Panel, which either is on the front of or mounted on top of the dishwasher. Stero offers two different types of dishwasher controls. The two types of controls are:

- Push Button Control Panel
- LCD Control Panel

Push Button Control Panel

The Push Button Control Panel consists of the following controls, which are explained in the OPERATING CONTROLS FUNCTION section of this manual:

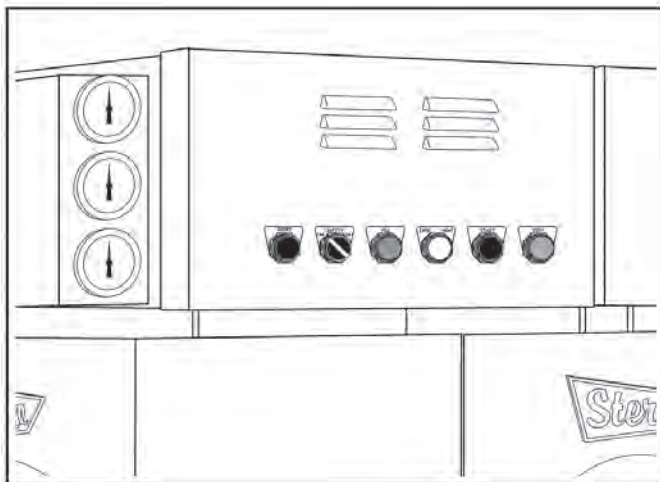

Figure 8

- SAFETY switch
- FILL button
- HEAT button
- START button
- STOP button
- Optional BOOSTER HEAT button
- Optional RESET button

Temperature Gauges

Also located on the front or top of the dishwasher are the temperature gauges. The temperature gauges provide a visual indication for the water temperatures within each section of the dishwasher.

The gauges are clearly labeled and, depending on model and type, are for the following sections:

- Scrap tank water temperature
- Wash tank water temperature
- Rinse tank water temperature
- Final Rinse water temperature

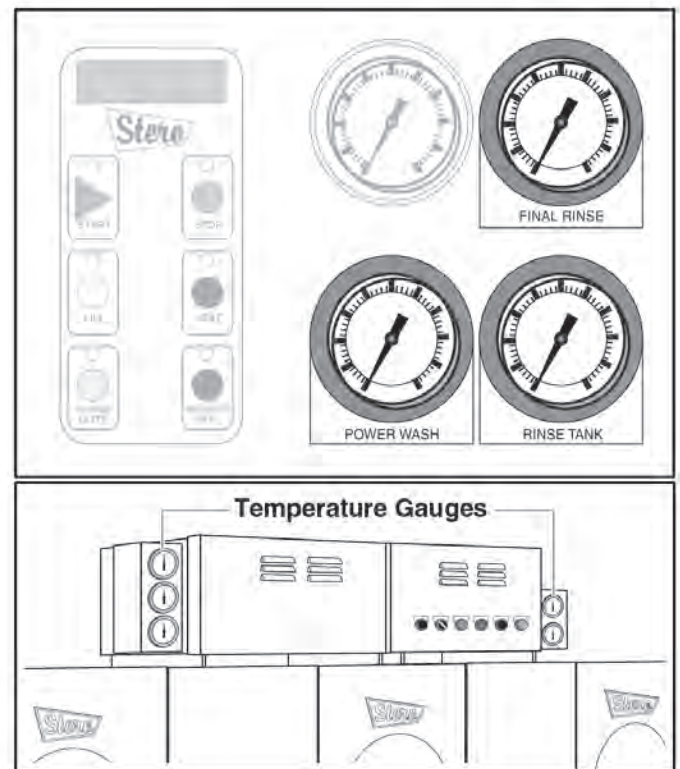

Figure 9

OPERATING CONTROLS FUNCTION

PUSH BUTTON CONTROL PANEL

SAFETY Switch

The SAFETY switch energizes the dishwasher electrical circuit when placed ON. The SAFETY switch is located on the Main Electrical Control Panel.

FILL Button

The FILL button energizes the Fill valves to fill the tanks with water. The FILL button will remain illuminated when pressed, until all the tanks are full. The FILL button is located on the Main Electrical Control Panel.

OPERATION *(continued)*

HEAT Button

The HEAT button energizes the dishwasher heating circuit. The HEAT button is illuminated when the tank heat is turned on and when the tanks are full. The HEAT button is located on the Main Electrical Control Panel.

START Button

The START button energizes the electrical pumps and conveyor drive. The START button is located on the Main Electrical Control Panel.

STOP Button

The STOP button stops the conveyor and pumps. The STOP button is located on the Main Electrical Control Panel.

(Optional) BOOSTER HEAT Button

The BOOSTER HEAT button is only present on units pre-wired with a steam Booster Heater. The BOOSTER HEAT button energizes the steam Booster Heater control circuit. The BOOSTER HEAT button, if preinstalled, is located on the Main Electrical Control Panel.

RUN CYCLE

Push Button Control Panel

To complete a run cycle for dishwasher with push button controls, perform the following:

[NOTICE] Water temperature inside the dishwasher can reach 190°F and cause severe burns.

1. Close all tank drain valves.
2. Make sure all Upper and Lower Spray Manifolds are securely in place and all end caps are tight.
3. Make sure all curtains are clean and securely in place.

NOTE: A Door Safety Switch prevents operation when the doors are open.

4. Close the access doors.
5. Turn the SAFETY switch to the ON position.
6. If gas-heated, push the RESET button.

7. To fill the tanks:
 - a. For dishwashers with Automatic Fill, press the FILL button. The button will illuminate until the tanks fill to the proper water levels.
 - b. For dishwashers without Automatic Fill, manually open the Fill valve(s) until the tanks are full then close the Fill valve(s).

8. Press the HEAT button. The button will illuminate and the tank Heaters will start to heat up to temperature. Allow the tanks to heat to the proper operating temperature (approx. 15-30 minutes).

9. If the dishwasher is equipped with an optional Booster Heater, either press:
 - a. The BOOSTER HEAT button located on the Main Electrical Control Panel (preinstalled steam Booster heaters).
 - b. The ON button located on the Booster Heater (electric and gas-heated Booster Heaters).

This will preheat the Booster Heater for approximately 10 minutes or until operating temperatures have been reached.

10. If equipped, press the START button. The pumps and conveyor motor will start.

NOTE: If the dishwasher is equipped with Automatic Start, the Start switch is activated by placing a dish rack into the load end of the dishwasher. The dishwasher will stop automatically when the Shutdown Timer time expires. The timer will reset when another dish rack is inserted.

NOTE: Final rinse temperature and flow pressure gauges are accurate only when a rack enters the final rinse area and water is flowing. Acceptable temperature range is 180°F-195°F and pressure should be 20 psi.

NOTE: Wash dishes in batches to conserve energy, water and soap.

NOTE: An optional Table Limit Switch mounted on the end of the clean dish table will stop the Conveyor and prevent a jam. Remove dish racks before they reach and open the Table Limit Switch.

OPERATION *(continued)*

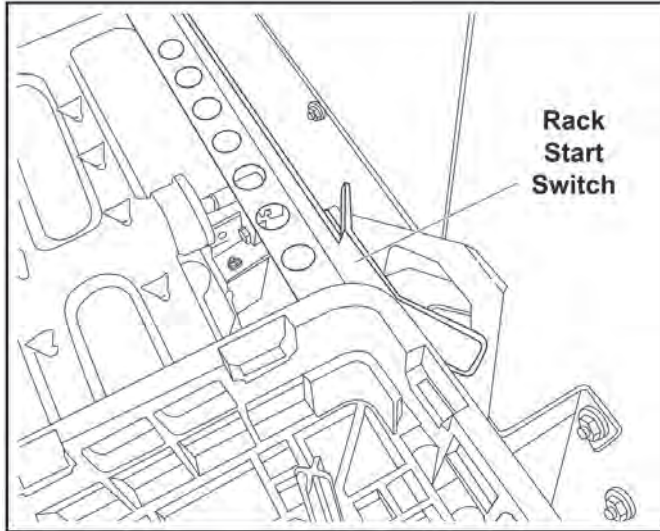

Figure 10

11. Place the dish rack into the load end of the dishwasher, the dish rack will advance through the dishwasher. The Pawl Bar will stop either when the rack reaches the optional Table Limit Switch or when the Shutdown Timer time expires.
12. To restart the dishwasher:
 - a. On dishwashers equipped with a Table Limit Switch, remove the dish rack from the Table Limit Switch.
 - b. On dishwashers equipped with a Shutdown Timer, the dishwasher will automatically restart when a dish rack trips the Start Switch or when the START button is depressed.
13. At the end of the shift, turn the SAFETY Switch located on the Control Panel to the OFF position.
14. Open the tank drain valves.

Refer to the *CLEANING* section of this manual for cleaning procedures.

SHUTDOWN

Daily Shutdown

At the end of each shift or washing period, the following steps will insure proper results from your Stero dishwasher.

1. Shut off all power to the dishwasher, place the SAFETY Switch or power ON/OFF Switch to the OFF position.
2. Turn the Drain levers or handles for all tanks to the OPEN position.
3. Open all the doors.
4. If applicable, perform the SCRAPER SPRAY MANIFOLD REMOVAL procedure.
5. Perform the TREE-TYPE SPRAY MANIFOLD REMOVAL Procedure.
6. Perform the STRAINER PANS REMOVAL Procedure.
7. Perform the CURTAIN REMOVAL Procedure.
8. The Spray Manifolds, Strainer Pans and Curtains should be cleaned as per the procedures in the CLEANING section.
9. Perform the dishwasher INTERIOR CLEANING Procedure.
10. Perform the EXTERIOR CLEANING Procedure.
11. Install the Strainer Pans, reversing the STRAINER PANS REMOVAL Procedure.
12. Install the Curtains, reversing the CURTAIN REMOVAL Procedure.
13. Install the Spray Manifolds, reversing the TREE-TYPE SPRAY MANIFOLD REMOVAL Procedure.
14. Leave all the doors open to allow the interior of the dishwasher to air dry.

Extended Shutdown

If the dishwasher is not going to be in operation for an extended period:

1. Perform the DAILY SHUTDOWN Procedure.
2. Turn the circuit breakers OFF.
3. Drain pump housings.

MAINTENANCE

PARTS REMOVAL

Scrapper Spray Manifold Removal

1. Perform the DAILY SHUTDOWN Procedure steps 1 - 5.
2. Locate the Mounting Clamp handle or Hand Grip clamp located at the front of the Scrapper Spray Manifold.

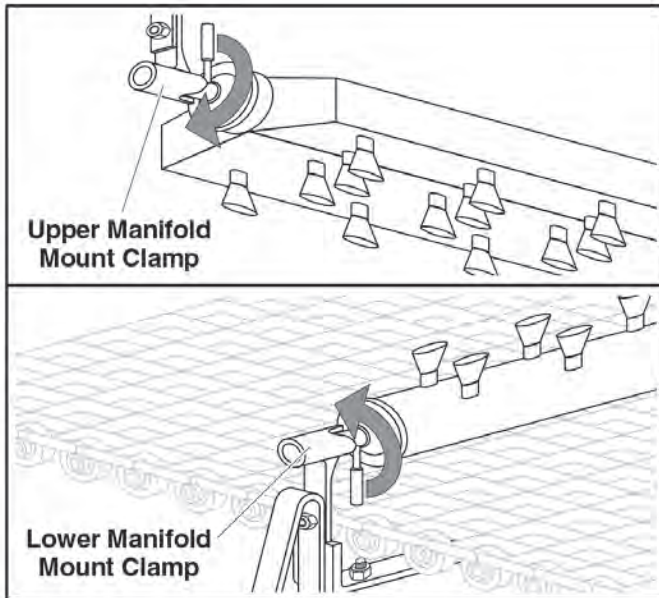

Figure 11

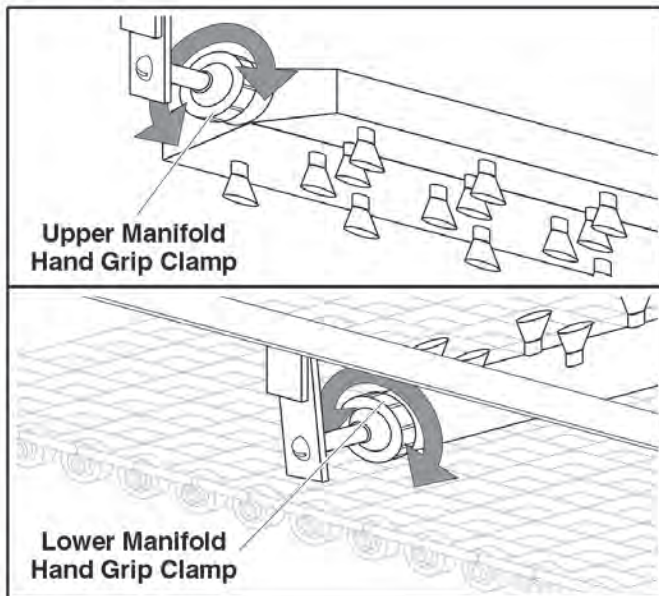

Figure 12

3. While holding onto the Scrapper Spray Manifold either:
 - a. Rotate the Mounting Clamp handle counterclockwise to release the Scrapper Spray Manifold (Figure 11).
 - b. Unscrew the Manifold Hand Grip clamp to loosen the Scrapper Spray Manifold (Figure 12).
4. Slide the Scrapper Spray Manifold assembly toward the front of the dishwasher to disengage it from the rear water line connection.
5. Carefully pull the Scrapper Spray Manifold out of the dishwasher.
6. Repeat the procedure for the Lower Scrapper Spray Manifold assembly.
7. Refer to the CLEANING section for procedures to clean the Scrapper Spray Manifolds.
8. When the Scrapper Spray Manifold has been cleaned, reinstall by reversing the above steps.

Tree-Type Spray Manifold Removal

1. Perform the DAILY SHUTDOWN Procedure steps 1 - 5.
2. Locate the Mounting Clamp handle or Hand Grip clamp located at the front of the Spray Manifold.

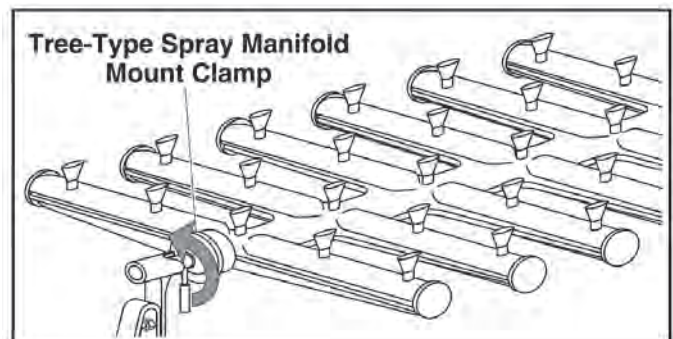

Figure 13

MAINTENANCE *(continued)*

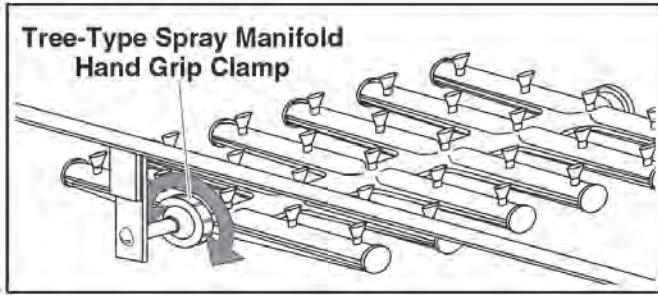

Figure 14

3. While holding onto the Spray Manifold either:
 - a. Rotate the Mounting Clamp handle counterclockwise to release the Spray Manifold (Figure 13).
 - b. Unscrew the Manifold Hand Grip clamp to loosen the Spray Manifold (Figure 14).
4. Slide the Spray Manifold assembly toward the front of the dishwasher to disengage it from the rear water line connection.
5. Carefully pull the Spray Manifold out of the dishwasher.
6. Repeat the procedure for the remaining Spray Manifold assemblies.
7. Refer to the CLEANING section for procedures to clean the Spray Manifolds.
8. When the Spray Manifolds have been cleaned, reinstall by reversing the above steps.

Curtain Removal

Curtain configurations vary depending on model. Refer to the curtain placement decals for correct curtain placement. Removal procedures are the same for all curtains.

1. Perform the DAILY SHUTDOWN Procedure steps 1 through 8.
2. Reach inside to locate the top of the curtain rod end.
3. Lift one end of the curtain rod up and out of its holder.
4. Locate the other end of the curtain rod end and lift it out of its holder.

5. Carefully remove the rod and curtain from the washer.
6. Repeat this process until all curtains and rods have been removed.
7. Refer to the CLEANING section for curtain cleaning procedures.
8. To reinstall the curtains, reverse above steps.

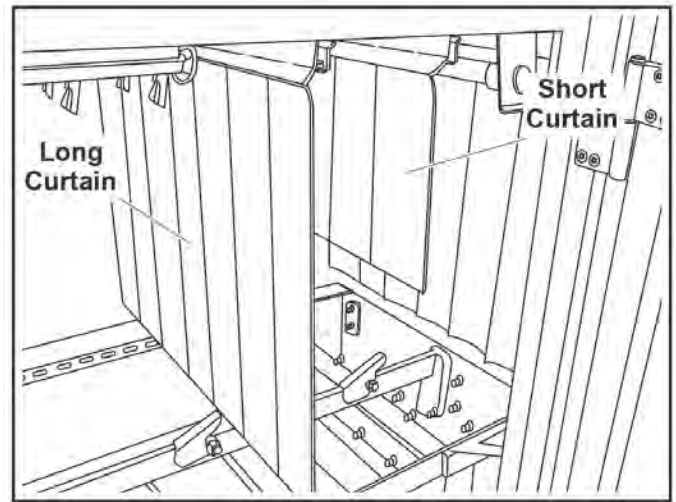

Figure 15

Strainer Pans Removal

NOTE: Clean the interior of the dishwasher before removing the Strainer Pans.

1. Perform the TREE-TYPE SPRAY MANIFOLD REMOVAL procedure to remove the Lower Spray Manifolds.

NOTICE The Strainer Pans are set atop the scrapper, wash and rinse tanks. Do not allow the collected material to spill from the Strainer Pans into the water tanks.

NOTE: The Strainer Pans for the scrapper tank are installed with the perforated side up to allow the food soil to wash into the outboard scrap basket. The wash and rinse Strainer Pans are installed with their perforated sides down to collect the food soil.

2. Remove the loose soil from the tank Strainer Pans.
3. Carefully lift and remove all of the Strainer Pans from the dishwasher.

MAINTENANCE *(continued)*

4. The Strainer Pans should be thoroughly cleaned in a sink before reinstalling back into the dishwasher.
5. To reinstall the Strainer Pans, reverse the above steps.

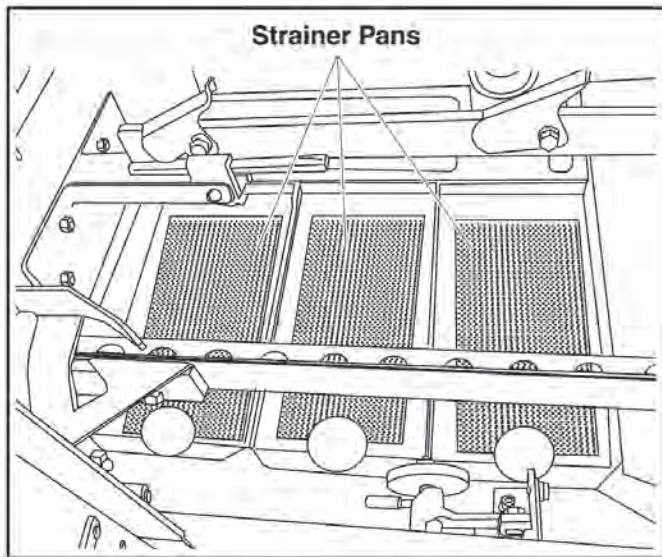

Figure 16

CLEANING

NOTICE Never use any metal tools. Scrapers, files, wire brushes or scouring pads (except for stainless steel scouring pads), will mar the surface!

NOTICE Never use steel wool, which will leave behind particles that can rust!

NOTICE Never use acid-based or chloride-containing cleaning solutions, which will break down the protective film!

NOTICE Never rub in a circular motion!

NOTICE Never leave any food products or salt on the surface. Many foods are acidic. Salt contains chloride!

Interior

This procedure should be performed based upon a schedule pre-determined for your operation.

To clean the interior of the dishwasher, perform the following:

1. Perform the DAILY SHUTDOWN Procedure steps 1 - 7.
2. Wash the interior compartment of the dishwasher with a solution of mild detergent and warm water.
3. Remove any food particles that remain between the drain valve and the seat.
4. Rinse the interior of the dishwasher with warm water and flush food soil through the floor drains.
5. Leave all the doors open to allow the interior of the dishwasher to air dry.

Spray Manifolds (Tree-Type and Scrapper)

All the Spray Manifold assemblies should be thoroughly cleaned before reinstalling into the dishwasher. To clean the Spray Manifolds perform the following:

1. Perform the DAILY SHUTDOWN Procedure steps 1 - 7.
2. Take the Spray Manifolds to a sink and thoroughly wash them with a solution of mild detergent and warm water.
3. Clean out the Spray Manifold spray nozzles with a paper clip to remove any collected food particles.
4. Rinse the Spray Manifolds thoroughly.

Curtains

It is essential that the dishwasher curtains be cleaned daily. To clean the dishwasher curtains perform the following:

1. Perform the DAILY SHUTDOWN Procedure steps 1 - 6.
2. Take all the curtains and rods to a sink.

MAINTENANCE *(continued)*

3. Thoroughly clean the curtain flaps with a solution of mild detergent and warm water.
4. Clean between the curtain flaps with a fiber bristled brush.
5. Thoroughly rinse the curtains.
6. Allow the curtains to air-dry before installing back into the dishwasher.

Exterior

Clean the floor around the base of the washer and under the table to prevent soil accumulation.

STAINLESS STEEL CARE

Cleaning

Stainless steel contains 70-80% iron, which will rust if not properly maintained. It also contains 12-30% chromium, which forms an invisible passive, protective film that shields against corrosion. If the film remains intact, the stainless steel will remain intact. However, if the film is damaged, the stainless steel can break down and rust. To prevent stainless steel breakdown, follow these steps:

NOTICE Never use any metal tools. Scrapers, files, wire brushes or scouring pads (except for stainless steel scouring pads), will mar the surface!

NOTICE Never use steel wool, which will leave behind particles that can rust!

NOTICE Never use acid-based or chloride-containing cleaning solutions, which will break down the protective film!

NOTICE Never rub in a circular motion!

NOTICE Never leave any food products or salt on the surface. Many foods are acidic. Salt contains chloride!

For routine cleaning, use warm water, mild soap or detergent and a sponge or soft cloth.

For heavy-duty cleaning, use warm water, a degreaser and a plastic, stainless steel or Scotch-Brite pad.

- Always rinse thoroughly.
- Always rub gently in the direction of the steel grain.

Preserving & Restoring

Special stainless steel polishing cleaners can preserve and restore the protective film.

Preserve the life of stainless steel with a regular application of a high quality stainless steel polishing cleaner as a final step to daily cleaning.

If signs of breakdown appear, restore the stainless steel surface. First, thoroughly clean, rinse and dry the surface. Then, on a daily basis, apply a high-quality stainless steel polish according to manufacturer's instructions.

DELIMING

Contact your Chemical Supplier for Deliming chemicals and procedures.

TROUBLESHOOTING

The following table lists common operator permitted troubleshooting remedies. If the remedy does not correct the symptom, shut down the dishwasher and contact your local factory-authorized Stero service professional.

SYMPTOM	POSSIBLE CAUSES	REMEDY
Dishwasher will not start.	Tripped circuit breaker SAFETY Switch is in the OFF position	Reset the circuit breaker. Place the SAFETY switch to the ON position.
Dishwasher will not fill.	Drain valve is open	Close the drain valve.
Dishwasher will not hold water.	Drain valve is open Drain valve not closing	Close the drain valve. Check the drain valve seat for food particles.
Dishwasher overfills.		Contact a factory-authorized Stero service professional.
Pump motor starts then stops.	Spray Manifolds are clogged	Remove and clean the Spray Manifolds per the CLEANING section of the manual. If the condition persists, contact a factory-authorized Stero service professional.
Dish racks will not convey through the dishwasher.	Dish rack ladders have broken or worn rungs Table Limit Switch, if equipped, is in the up position	Replace dish racks. Reset the Table Limit Switch.
Dishwasher runs for a few minutes then shuts off.	Incorrect settings on the Shutdown Timer	Contact a factory-authorized Stero service professional.
Dishwasher is not washing properly.	Spray Manifolds are clogged Detergent container is empty Low water level in the tanks	Remove and clean the Spray Manifolds per the CLEANING section of the manual. Contact the detergent provider. Allow the water in the tanks to refill.
Dishwasher is not rinsing properly.	Plugged Final Rinse sprayers Empty Rinse-Dry Container	Remove and clean the Final Rinse sprayers per the CLEANING section of this manual. Contact the detergent provider.
Dishwasher will not come up to temperature. (Electric Tank Heat)	Tripped circuit breaker Tank HEAT switch is not ON	Reset tripped circuit breaker. Press the tank HEAT button. Allow the dishwasher to reach its operating temperature (approximately 15-30 minutes).
Dishwasher will not come up to temperature. (Steam Tank Heat)	Steam supply valve is closed Steam return valve is closed	Open steam supply valve. Open steam return valve.
Final Rinse will not come up to temperature.		Contact a factory-authorized Stero service professional.

PRODUCT SUPPORT AND SERVICE _____

To obtain service and parts information concerning this model, contact the Stero authorized service provider in your area (refer to our website, www.stero.com, for a complete listing of authorized service and parts locations).

When calling for service, the following information must be available:

- Model Number: _____
- Serial Number: _____
- Voltage: _____

STERO WARRANTY

This warranty is in lieu of all other warranties, expressed or implied, including without limitation any implied warranty of merchantability, fitness for a particular purpose or non-infringement, and of any other obligation or liability on the part of Stero, whether in contract, strict liability, tort or otherwise.

The Stero Company warrants this equipment to be free from defects in material and workmanship, under normal use and operation, for a period of one (1) year from the date of initial start up or eighteen (18) months from the date of shipment from the factory, whichever comes first. This warranty is conditioned upon the customer's maintenance and care as outlined in the service manual and upon return of the warranty registration card. Repairs will be performed during Stero's authorized service agency's normal business hours. If the customer requires after hours service, the customer will be responsible for the overtime premium.

Machine is warranted only for the initial place of installation. Removal of machine automatically terminates the warranty. Stero shall have no liability under this warranty unless the customer promptly notifies Stero or its factory authorized service agent of any alleged defects. All defective parts become the property of Stero and must be returned to Stero, or its agent, at Stero's expense, within thirty (30) days from the date of the part's replacement. Parts replaced within the warranty carry only the unexpired portion of the machine's warranty.

Not covered by this warranty are changes (parts and/or labor) necessitated by or damage resulting from: water conditions, accident, alteration, improper use, abuse, tampering, improper installation, or failure to follow operating and maintenance procedures. Examples of the foregoing, but without limitations are: (1) Damage to the machine resulting from excessive concentrations of chlorine or delimiting acid solutions; (2) Use with utility service other than designated on the rating plates; (3) Improper connection to utility service; (4) Inadequate or excessive water and/or steam pressure; (5) Leaks caused by faulty installation; (6) Component failures caused by water leaks due to faulty installation; (7) Failure to comply to local building codes; (8) Failures due to deposits resulting from water or steam conditions, detergents, chemicals, or improper cleaning; (9) Resetting breakers, overloads, or safety thermostats; (10) Adjustments of thermostats after 90 days of operation; (11) Improper opening of utility supply valves; (12) Cleaning drain valves, line strainers, rinse nozzles, etc.; (13) Improper installation or malfunction of chemical dispensing equipment supplied by others; and (14) Failure to provide regular maintenance and daily cleaning as outlined in the service manual. In no event will Stero be liable for loss or damage to or loss of use of facilities or other property, additional labor costs, loss of revenue, loss of anticipated profits, or other damages of any kind what-so-ever, whether direct, indirect, incidental or consequential.

⚠ WARNING If not installed, operated and maintained in accordance with the manufacturer's instructions, this product could expose you to fuel or fuel combustion substances, which can cause death or serious illness and which are known to the State of California to cause cancer, birth defects or other reproductive harm.

The State of California enacted the California Safe Drinking Water and Toxic Enforcement Act of 1986, (Prop. 65), which "prohibits any person in the course of doing business from knowingly and intentionally exposing any individual to a chemical known to the State of California to cause cancer or reproductive toxicity without first giving clear and reasonable warning to such individuals." The Governor's Scientific Advisory Panel added carbon monoxide to the list of hazardous chemicals known to cause reproductive harm.

In order to establish full compliance with Proposition 65, an orange warning label has been attached to each gas-fired unit manufactured by Stero.

Carbon monoxide would not be present in concentrations that would pose a "significant risk" to the consumer when the equipment is installed, operated and maintained as follows:

1. Installed in accordance with all local codes, or in the absence of local codes, with the current National Fuel Gas Code ANSI Z223.1 Latest Addenda.

2. Installed under a properly designed and operating exhaust hood.
3. Connected to the type of gas for which the unit is equipped.
4. Proper appliance pressure regulator installed on the gas supply line and adjusted for the manifold pressure marked on the rating plate.
5. Adequate air supply to the unit.
6. The equipment is operated in the manner intended and using the proper utensil for that type of appliance.
7. Keep the equipment clean and have it checked periodically.
8. Burner air adjustments, mechanical maintenance and repairs must be performed by qualified service personnel.

If the equipment is not installed, operated and maintained in accordance with the above requirements, concentrations of carbon monoxide in excess of the established limits could be present in the kitchen environment.

ALL PERSONNEL IN THE WORKPLACE WHO MAY BE SUBJECT TO ANY EXPOSURE OF CARBON MONOXIDE MUST BE WARNED OF SUCH POSSIBLE EXPOSURE. THIS WARNING SHOULD BE CONVEYED IN A MANNER SO THAT IT IS CLEARLY UNDERSTOOD BY THE EMPLOYEE. THE EMPLOYEE MUST BE ASKED IF IN FACT HE OR SHE UNDERSTANDS THE CORRECT METHOD OF OPERATION OF THE EQUIPMENT AND THAT A RISK OF EXPOSURE EXISTS IF THE EQUIPMENT IS OPERATED IMPROPERLY.

NOTES



STERO, a division of Illinois Tool Works, Inc. 165 Independence Court Lancaster, PA 17601
Phone: 800-762-7600 Fax: 707-762-5036 Website: Stero.com



Stero, a division of Illinois Tools Works Inc.
 3200 Lakeville Highway
 Petaluma, CA 94954-5675
 Phone: (800) 762-7600
 (707) 762-0071
 Fax: (707) 762-5036

New Equipment Performance and Installation Inspection Report

Date: _____

Customer Information

Location _____	Contact Name _____
Address _____	City _____ State _____
Phone _____	Fax _____ Zip _____

Service Agency Information

Company _____ Technician Name _____
 City _____ State _____ Zip _____ Phone _____

Equipment Information

Model _____ Serial Number _____ V _____ Ph _____
 Date of Installation _____ Steam-Heated _____ SWB Gas-Heated _____ WC _____

Installation Checklist

- | | | | |
|------------------------------|-----------------------------|---|--|
| <input type="checkbox"/> N/A | <input type="checkbox"/> OK | <input type="checkbox"/> Machine leveled | |
| <input type="checkbox"/> | <input type="checkbox"/> | <input type="checkbox"/> Voltage/Phase correct _____ V _____ Ph | |
| <input type="checkbox"/> | <input type="checkbox"/> | <input type="checkbox"/> Circuit breaker(s) sized correctly _____ A | |
| <input type="checkbox"/> | <input type="checkbox"/> | <input type="checkbox"/> Water pressure meets min. requirements _____ PSI | |
| <input type="checkbox"/> | <input type="checkbox"/> | <input type="checkbox"/> Water supply temperature meets min. requirements _____ F | |
| <input type="checkbox"/> | <input type="checkbox"/> | <input type="checkbox"/> Plumbing checked for leaks | |
| <input type="checkbox"/> | <input type="checkbox"/> | <input type="checkbox"/> Fill/Drain lines plumbed correctly | |
| <input type="checkbox"/> | <input type="checkbox"/> | <input type="checkbox"/> Spray Manifolds in place and secure | <input type="checkbox"/> N/A <input type="checkbox"/> OK |
| <input type="checkbox"/> | <input type="checkbox"/> | <input type="checkbox"/> Strainer Pans in place | <input type="checkbox"/> <input type="checkbox"/> Soap dispenser installed |
| <input type="checkbox"/> | <input type="checkbox"/> | <input type="checkbox"/> Curtains in proper place | <input type="checkbox"/> <input type="checkbox"/> Rinse Injector installed |
| <input type="checkbox"/> | <input type="checkbox"/> | <input type="checkbox"/> Dampers adjusted/working properly | <input type="checkbox"/> <input type="checkbox"/> Parts manual included |
| <input type="checkbox"/> | <input type="checkbox"/> | <input type="checkbox"/> Motor rotation is correct | |
| <input type="checkbox"/> | <input type="checkbox"/> | <input type="checkbox"/> Conveyor Belt Tension adjusted properly | |
| <input type="checkbox"/> | <input type="checkbox"/> | <input type="checkbox"/> Steam Condensate/Return line routed correctly | |

Demonstration Checklist

(To be completed by Stero Representative)

- | | | |
|------------------------------|-----------------------------|---|
| <input type="checkbox"/> N/A | <input type="checkbox"/> OK | <input type="checkbox"/> Demonstrated RUN cycle |
| <input type="checkbox"/> | <input type="checkbox"/> | <input type="checkbox"/> Demonstrated Shutdown procedures |
| | | <input type="checkbox"/> Warranty policy explained |
| | | <input type="checkbox"/> Cleaning procedures explained |
| | | <input type="checkbox"/> Normal maintenance procedures demonstrated |

Water Temperatures

- | | | |
|------------------------------|-----------------------------|--|
| <input type="checkbox"/> N/A | <input type="checkbox"/> OK | <input type="checkbox"/> Scrapper Temperature _____ F |
| | | <input type="checkbox"/> Wash Temperature _____ F |
| | | <input type="checkbox"/> Rinse Temperature _____ F |
| | | <input type="checkbox"/> Auxiliary Rinse Temperature _____ F |
| | | <input type="checkbox"/> Final Rinse Temperature _____ F |

Booster Heater Information N/A _____ V _____ Ph

Manufacturer _____ Model _____
 Serial No. _____ Type of Heat _____

The above machine has been inspected and demonstrated in the presence of the customer by a representative authorized by Stero.

 Stero Representative Signature

 Customer Signature

All new Stero Dishwashing Machines are warranted against defects in workmanship and materials for a period of one year from date of start-up by the original owner. Warranty card MUST be filled out and RETURNED to the manufacturer within 10 days from the date of delivery to the original owner. Warranty does not apply to any dishwasher which has been subject to accident, alteration, misuse or damages resulting from incorrect installation on the part of the contractor.

Any repair work performed on the above dishmachine by persons other than Authorized Stero Service Agencies is the sole responsibility of the customer.

 Customer

 Service Agent

CUT HERE

