

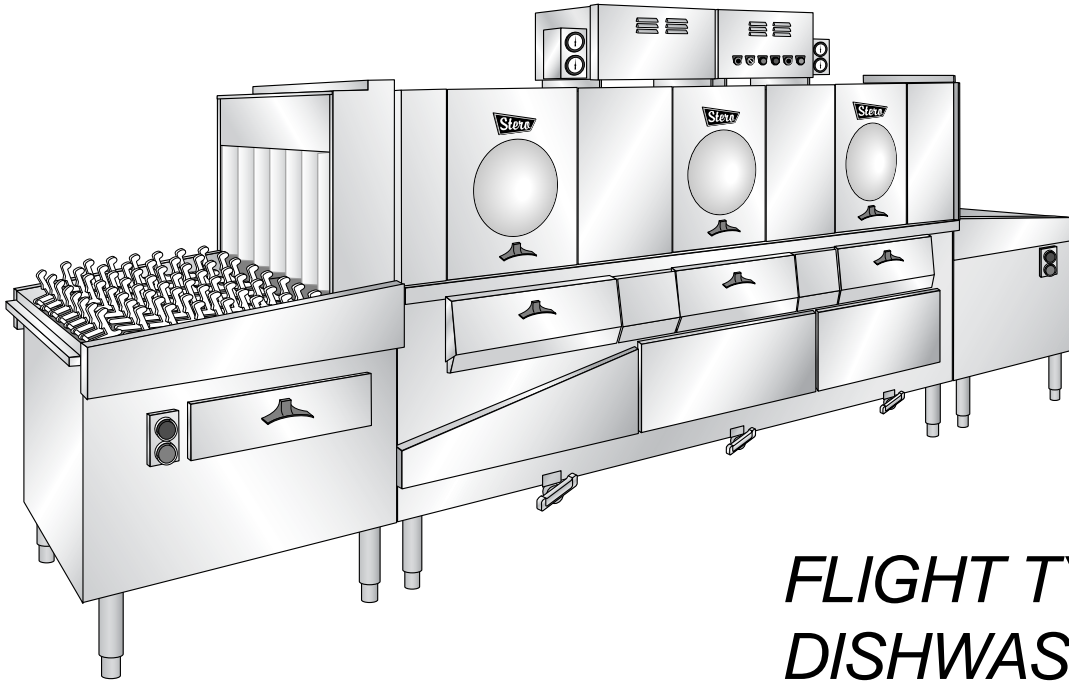

# INSTALLATION & OPERATION MANUAL



## FLIGHT TYPE DISHWASHERS

### MODELS

STPC  
STPCW  
STPCW-D  
STBUW

For additional information on Stero or to locate an authorized parts and service provider in your area, visit our website at [www.stero.com](http://www.stero.com).

## IMPORTANT FOR YOUR SAFETY

**ONLY QUALIFIED PERSONNEL SHOULD PERFORM THE INITIAL FIELD STARTUP AND ADJUSTMENTS OF THE EQUIPMENT COVERED BY THIS MANUAL.**

**READ THIS MANUAL THOROUGHLY BEFORE OPERATING, INSTALLING OR PERFORMING MAINTENANCE ON THE EQUIPMENT.**

**⚠ WARNING** Improper installation, adjustment, alteration, service or maintenance can cause property damage, injury or death.

**Post in a prominent location the instructions to be followed in the event the smell of gas is detected. This information can be obtained from the local gas supplier.**

### IMPORTANT

**IN THE EVENT A GAS ODOR IS DETECTED, SHUT DOWN UNITS AT MAIN SHUTOFF VALVE AND CONTACT THE LOCAL GAS COMPANY OR GAS SUPPLIER FOR SERVICE.**

### FOR YOUR SAFETY

**Do not store or use gasoline or other flammable vapors or liquids in the vicinity of this or any other appliance.**

**⚠ WARNING** Shut off the gas before servicing the unit.

**⚠ WARNING** All gas joints disturbed during servicing must be checked for leaks. Check with a soap and water solution (bubbles). Do not use an open flame.

**⚠ WARNING** Shut off the steam before servicing the unit.

**⚠ WARNING** Disconnect the electrical power to the machine and follow Lockout/Tagout procedures. There may be multiple circuits. Be sure all circuits are disconnected.

**⚠ WARNING** Electrical and grounding connections must comply with the applicable portions of the National Electric Code and/or other local electrical codes.

**⚠ WARNING** UL73 grounding instructions: This appliance must be connected to a grounded, metal, permanent wiring system; or an equipment-grounding conductor must be run with the circuit conductors and connected to the equipment-grounding terminal or lead on the appliance.

**IN THE EVENT OF A POWER FAILURE,  
DO NOT ATTEMPT TO OPERATE THIS DEVICE.**

# TABLE OF CONTENTS

IMPORTANT FOR YOUR SAFETY .....	2
GENERAL .....	5
INTRODUCTION .....	5
LOCATION OF DATA PLATE .....	5
TOOLS .....	6
Standard .....	6
Special .....	6
PRE-INSTALLATION .....	6
Utility Connection Requirements .....	6
INSTALLATION .....	7
CODES AND STANDARDS .....	7
UNCRATING .....	7
ASSEMBLY .....	7
Load Section Installation .....	8
Unload Section Installation .....	9
Leveling .....	11
Conveyor Peg Belt Installation .....	11
Conveyor Peg Belt Tension Adjustment .....	13
Conveyor Stop Bar Switch Electrical Connection .....	13
Curtain Installation .....	14
VENTILATION DUCT CONNECTION (if required) .....	14
Gas-Heated Dishwashers .....	14
Steam or Electric-Heated Dishwashers .....	14
Electrical Connections .....	14
UTILITY CONNECTIONS .....	15
PLUMBING CONNECTIONS .....	15
Water Supply Connections .....	15
Drain Connections .....	15
Steam Connections .....	16
GAS CONNECTIONS .....	16
Gas Lockout/Tagout Procedure .....	16
ELECTRICAL CONNECTIONS .....	17
Electrical Lockout/Tagout Procedures .....	17
Main Electrical Supply .....	17
Chemical Supply Connections .....	17
ADJUSTMENTS AND TESTS .....	18
PUMP MOTOR CHECK .....	18
CONVEYOR BELT TENSION CHECK .....	18
V-BELT TENSION ADJUSTMENT .....	18

OPERATION .....	20
OPERATING CONTROLS LOCATION .....	20
Push Button Control Box .....	20
LCD Control Box .....	20
OPERATING CONTROLS FUNCTION .....	21
Push Button Control Box .....	21
LCD Control Box .....	21
RUN CYCLE .....	22
Push Button Control Box .....	22
LCD Control Box .....	22
SHUTDOWN .....	23
Daily Shutdown .....	23
MAINTENANCE .....	24
PARTS REMOVAL .....	24
Scrapper Spray Manifold Removal .....	24
Tree-Type Spray Manifold Removal .....	24
Curtain Removal .....	25
Strainer Pan Removal .....	25
CLEANING .....	26
Interior .....	26
Spray Manifolds (Tree-Type and Scrapper) .....	26
Curtains .....	26
Exterior .....	26
STAINLESS STEEL CARE .....	27
Cleaning .....	27
Preserving and Restoring .....	27
DELIMING .....	27
TROUBLESHOOTING .....	28
LCD DISPLAY MESSAGES .....	28
OPERATIONAL TROUBLESHOOTING .....	29
PRODUCT SUPPORT AND SERVICE .....	31
STERO WARRANTY .....	32
CALIFORNIA SAFE DRINKING WATER AND TOXIC ENFORCEMENT ACT OF 1986, (PROP. 65) .....	33
SERVICE AND INSTALLATION INSPECTION REPORT .....	35

# GENERAL

## INTRODUCTION

Every Stero product is built with the highest quality components and innovative features that have established Stero's reputation as the food service industry's warewashing authority.

Stero Flight-Type dishwasher models include the standard, STPC, the wide model STPCW, and the STPCW-ER which features a two-stage auxiliary rinse.

Automatic warewashers contain heaters that maintain the proper water temperature in the dishwasher tanks. These heaters use electricity, steam or gas. As a general rule, heaters maintain a tank temperature of 160°F (71°C) to ensure sanitation. Hot water sanitizing warewashing machines use a booster heater to raise the incoming, general purpose hot water to at least 180°F (82°C) for the final sanitizing rinse.

The NSF requires an established amount of heat content to ensure sanitation. The water pressure for this cycle must be 20 PSI.

The dishwasher consists of the following operations:

- Power Scraper
- Power Wash
- Power Rinse or EcoRinse™
- Final Rinse

## LOCATION OF DATA PLATE

The data plate (Figure 1) is located on the Main Electrical Control Box. This data plate contains important information, including the dishwasher model and serial number.

**Always have the model and serial number before calling for parts or service.**

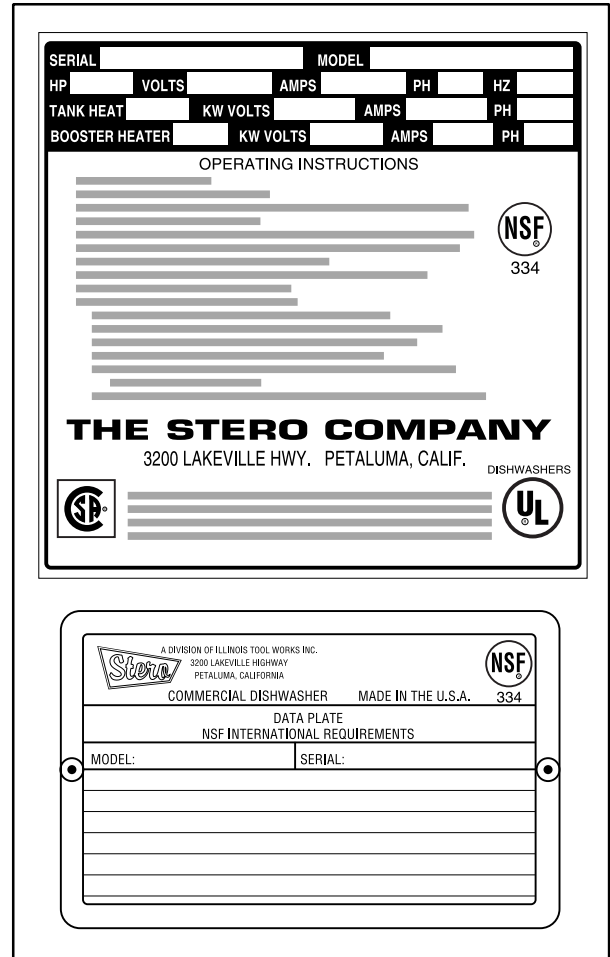

Figure 1: Data Plate

## TOOLS

### Standard

- Standard set of hand tools
- Gas leak detection equipment (gas-heated equipment installation only)
- Gas pressure Manometer (gas-heated equipment installation only)

### Special

- NSF approved silicone sealant
- Torx security screwdriver (correctional facility equipment only)
- Pipe joint compound
- At least 50 Ft of rope (conveyor belt installation)
- Heavy-duty wire ties or bailing wire (conveyor belt installation)
- Bubble level
- Floor jack

## PRE-INSTALLATION

### Utility Connection Requirements

Utility connections must be present and ready for hook-up to the dishwasher. All utility supplies must comply with the electrical information labels, with the data plate, and with all applicable local and national codes.

Electrical leads, water supply line(s), drain line, gas and steam supply and condensate return lines (if so equipped) must be present. The water supply must match the pressure and temperature specified on the data plate. The steam or gas supply (if so equipped) must match the pressure and volume specified on the data plate.

For units using a chemical dispensing system, appropriate dispensers or containers should be installed and ready for connection to the dishwasher.

# INSTALLATION

## CODES AND STANDARDS

In the United States, the dishwasher must be installed in accordance with:

- State and local codes
- National Fuel Gas Code, ANSI-Z83.21, Commercial Dishwashing Machines (latest edition)
- National Fuel Gas Code, ANSI Z223.1 (latest edition)
- National Fire Protection Association, NFPA 54 (latest edition)
- Underwriters Laboratories standard UL 921, Commercial Dishwashers (latest edition)
- National Electrical Code NEC/NFPA 70 (latest edition)

In Canada, the dishwasher must be installed in accordance with:

- Local codes.
- Canadian Electrical Code Part 1 CSA C22.1(latest edition)
- CAN/CSA-C22.2 Number 168, Commercial Dishwashing Machines (latest edition)
- CAN/CSA B149.1, Natural Gas and Propane Installation (latest edition)

## UNCRATING

**NOTE:** As you unpack the equipment, check that all components shown on the shipping invoice are present. Be sure to check for shipping damage. If shipping damage is present, contact Stero Customer Service at 1-800-762-7600 and provide customer details, machine serial number and the extent of damage. Stero will file a freight claim based on this information.

**⚠ WARNING** Unless authorized by Stero Customer Service or its authorized agent, a damaged unit should not be installed or operated.

To uncrate the dishwasher, perform the following:

**NOTICE** The pallet should not be removed until the dishwasher has been moved to its installation area. Damage can occur from improper lifting and uneven weight distribution.

**NOTICE** Do not attempt to slide the dishwasher on its feet. This can bend the legs.

1. Remove all shipping and packaging material from the machine, including supports and wrappings.
2. Leave the pallet in place to allow for easier movement to the installation location.
3. Check for shipping damage as described above.

**NOTICE** Exercise care to avoid damaging the dishwasher or its components.

4. Move the dishwasher to the installation area and remove the pallet.

## ASSEMBLY

If the dishwasher does not require assembly, proceed to the LEVELING procedure.

**NOTE:** The dishwasher MUST be level for proper operation.

If the dishwasher requires assembly, proceed as follows:

1. When the main section of the dishwasher has been moved to the installation area, use a bubble level, check that the main section is level both front to back and left to right.
2. To adjust level, screw the feet in or out until the dishwasher is level both front to back and left to right.

3. Once the main section is level, position the load section of the dishwasher near the load end of dishwasher main section.
4. Position the unload section near the unload end of the main dishwasher section.

**NOTE:** Not all access panel screws are the same length. Place the screws back into the holes to aid in correct panel reinstallation and screw placement.

5. Tag and remove all the access panels from the load section of the dishwasher including the table and enclosure panels.
6. Tag and remove all the access panels from the unload section of the dishwasher including the table and enclosure panels.
7. Tag and remove all the access panels from the main dishwasher section including the water line enclosure panels and electrical junction boxes.

### Load Section Installation

To install the load section, proceed as follows:

1. Remove the 5/16" hex head bolts and washers from the butt joint on the load side of the main dishwasher section. Retain for reinstallation.

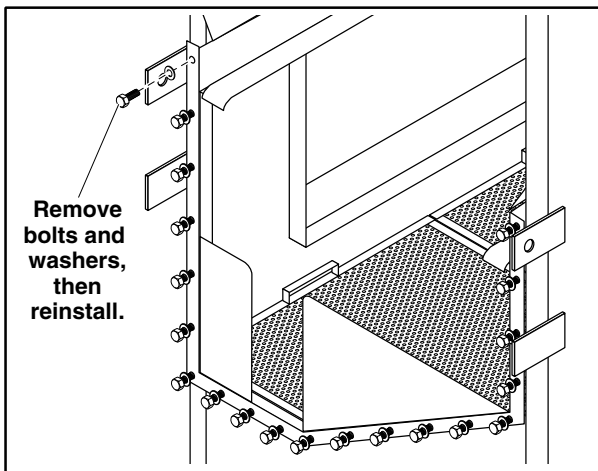

**Figure 2: Load End Tank Mount**

2. Remove the 3/8" hex bolts, hex nuts, flat washers and lock washers from the main dishwasher lower frame. Retain for reinstallation.

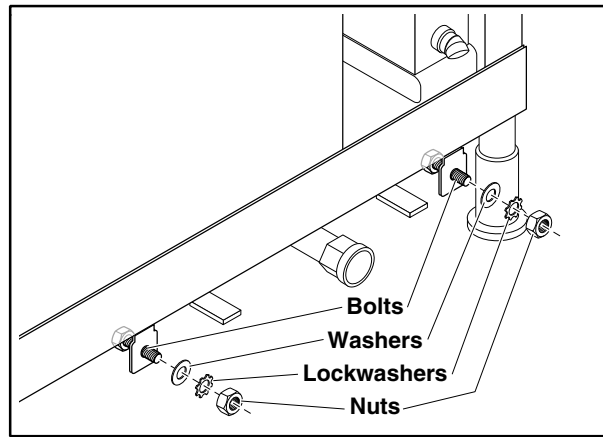

**Figure 3: Load End Frame Mount**

3. For dishwashers equipped with an extended Vent Cowl, remove the 5/16" hex nut and washer from each side of the vent cowl and retain for reinstallation.
4. Remove the two (2) countersunk screws from the main dishwasher load end R/H Belt Roller Guard Extension. Retain for reinstallation.
5. Remove the two (2) countersunk screws from the main dishwasher load end L/H Belt Roller Guard Extension. Retain for reinstallation.

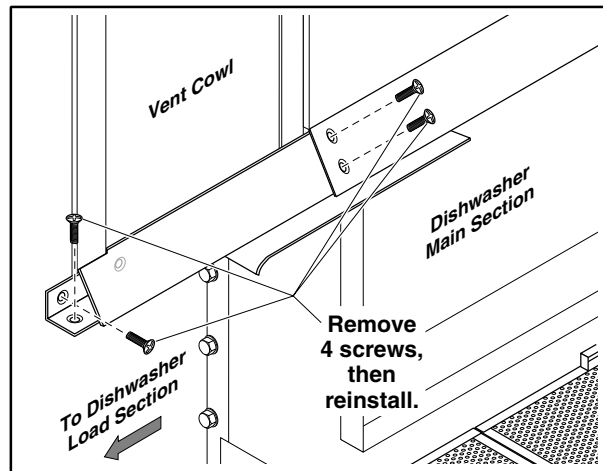

**Figure 4: Load Belt Roller Guard Extension**

7. Remove and discard any shipping tape from the load end drainpipe fitting and the main dishwasher load end drainpipe connection.
8. Using a Stero and NSF approved silicone sealant; apply a generous amount of silicone sealant to the entire Load End Butt Joint Gasket surface.

9. Check to make sure everything is lined up properly, then carefully move the load section into place with the main dishwasher. Make sure the Roller Guard Extensions and water line(s) are properly aligned before proceeding.
10. Align the tank **bolt** mount holes by placing a drift punch into the frame tabs.
11. Install, but **DO NOT** tighten, the 5/16" hex bolts that were removed in step 6.
12. Apply pipe joint compound and connect, but **DO NOT** tighten, the drainpipe connection between the main dishwasher and load end section.
13. Apply pipe joint compound and connect, but **DO NOT** tighten, the water line connection(s) located on the rear side of the main dishwasher load end.
14. Reinstall, but **DO NOT** tighten, the 3/8" frame hex bolts that were removed in step 7.
15. After checking to make sure all plumbing and electrical connections are properly aligned, tighten all the 5/16" butt joints bolts and 3/8" frame bolts.
16. Once the butt joint bolts and frame bolts have been tightened, tighten all remaining plumbing connections.
17. For dishwashers equipped with an extended Vent Cowl, reinstall the two (2) 5/16" hex nuts and washers removed in step 3.
18. For rear access dishwashers, make sure the Splash Back Panel is properly installed and secured to the load section as illustrated.

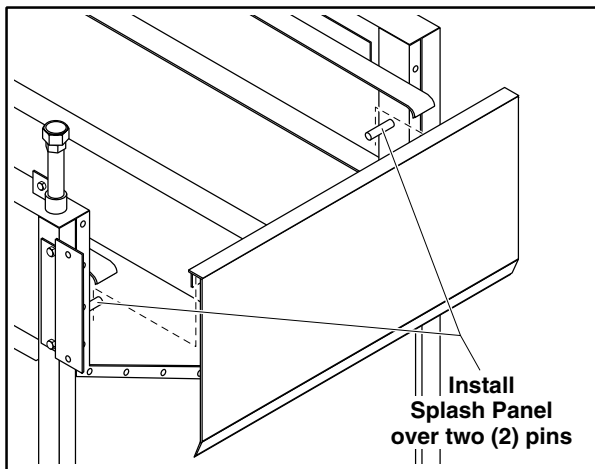

**Figure 5: Splash Back Panel Installation**

19. Reinstall the Roller Guard Extension countersunk screws removed in steps 9 and 10.
20. Route the wires from the load end remote START/STOP switch through the sealite connection on the junction box mounted on the main dishwasher.
21. Connect the four (4) wire connectors by matching either the wire colors or the wire numbers.
22. Connect all supply connections observing National and local code requirements.

**NOTE:** Do not reinstall the access panels at this time.

### Unload Section Installation

To install the unload section, proceed as follows:

1. Remove the 5/16" hex head bolts and washers from the butt joint on the unload side of the main dishwasher section. Retain for reinstallation.

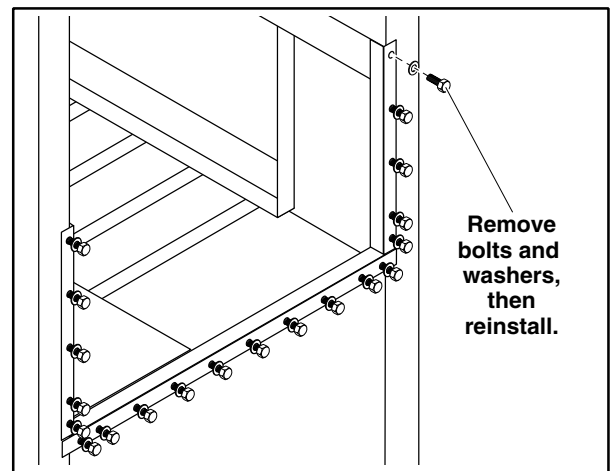

**Figure 6: Unload End Tank Mount**

2. Remove the 3/8" hex bolts, hex nuts, flat washers and lock washers from the main dishwasher lower frame. Retain for reinstallation.

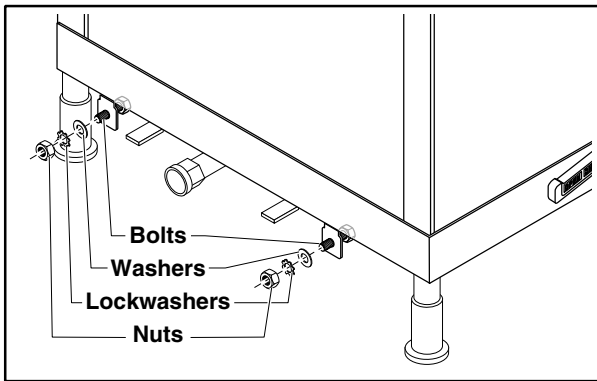

**Figure 7: Unload End Frame Mount**

3. For dishwashers equipped with an extended Vent Cowl, remove the 5/16" hex nut and washer from each side of the vent cowl. Retain for reinstallation.
4. Remove the two (2) countersunk screws from the main dishwasher unload end R/H Belt Roller Guard Extension. Retain for reinstallation.
5. Remove the two (2) countersunk screws from the main dishwasher unload end L/H Belt Roller Guard Extension. Retain for reinstallation.

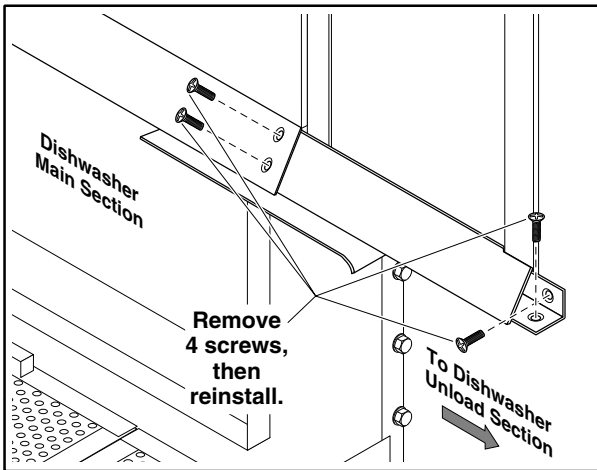

**Figure 8: Unload Belt Roller Guard Extension**

6. Remove and discard any shipping tape from the unload end drainpipe fitting and the main dishwasher unload end drainpipe connection.
7. Using a Stero and NSF approved silicone sealant; apply a generous amount of silicone sealant to the entire Unload End Butt Joint Gasket surface.

8. Check to make sure everything is lined up properly, then carefully move the unload section into place with the main dishwasher. Make sure the Roller Guard Extensions and water line(s) are properly aligned before proceeding.
9. Install, but DO NOT tighten, the 5/16" hex bolts that were removed in step 6.
10. Apply pipe joint compound and connect, but DO NOT tighten, the drainpipe connection between the main dishwasher and unload end sections.
11. Apply pipe joint compound and connect, but DO NOT tighten, the water line connection(s).
12. After checking to make sure all plumbing and electrical connections are properly aligned, tighten all the 5/16" butt joints bolts and 3/8" frame bolts.
13. Once the butt joint bolts and frame bolts have been tightened, tighten all remaining plumbing connections.
14. Reinstall the Roller Guard Extension countersunk screws removed in steps 9 and 10.
15. Route the pump motor wires and remote START/STOP switch wires from the main dishwasher section unload end through the sealtite connection on the junction box mounted to the unload section.
16. Connect the wire connectors by matching either the wire colors or the wire numbers.
17. For dishwashers equipped with an extended Vent Cowl, reinstall the two (2) 5/16" hex nuts and washers removed in step 8.
18. Connect all supply connections observing National and local code requirements.

**NOTE:** Do not reinstall the access panels at this time.

**Leveling**

For proper operation, the dishwasher must be level. To level the dishwasher after assembly:

1. Using a bubble level, check that the dishwasher is level both front to back and left to right.
2. Screw the feet in or out until the dishwasher is level both front to back and left to right.

### Conveyor Peg Belt Installation

**NOTE:** Whenever possible, two installers should be used to install the Conveyor Peg Belt.

**NOTE:** The Conveyor Peg Belt weighs between 300 lbs. (plastic) and 700 lbs. (stainless steel). Exercise care while handling.

**NOTICE** Gloves should be used while handling the Conveyor Peg Belt to reduce the possibility of personal injury.

To install the Conveyor Peg Belt, proceed as follows:

1. Loosen the two (2) Conveyor Motor Mount bolts. This will allow the V-belts to be removed from the pulleys and the Unload Drive Sprockets will turn freely.

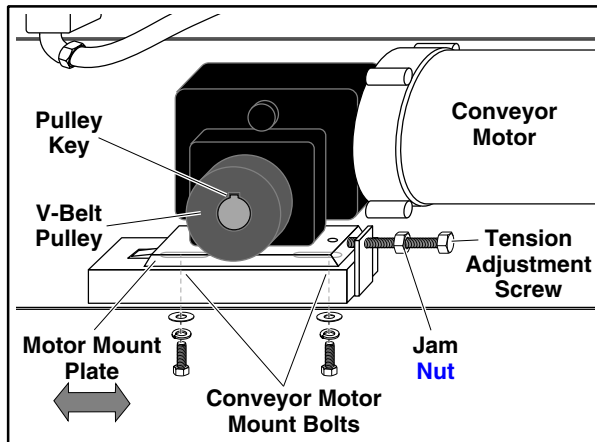

**Figure 9: Conveyor Motor V-Belt Tension Adjustment**

2. Open or remove all doors to gain access to the dishwasher during Conveyor Peg Belt installation.
3. Place the rolled up Conveyor Peg Belt at the very end of the load end of the dishwasher.

4. Starting at the load end, thread a piece of rope through the dishwasher, over the top of the Lower Spray Manifolds and continue to until you reach the Drive End shaft on the unload end.
5. Thread the rope around the Drive End shaft and back through the dishwasher. This time thread the rope below the Lower Spray Manifolds until the rope reaches the load section. Exit the rope through the last load inspection door.
6. Uncoil the Conveyor Peg Belt as much as possible on the floor, on the load end of the dishwasher. This makes it easier to feed the belt into the dishwasher.
7. Lay the end of the Conveyor Peg Belt onto the load section of the dishwasher with the pegs on the belt tilting away from the machine.

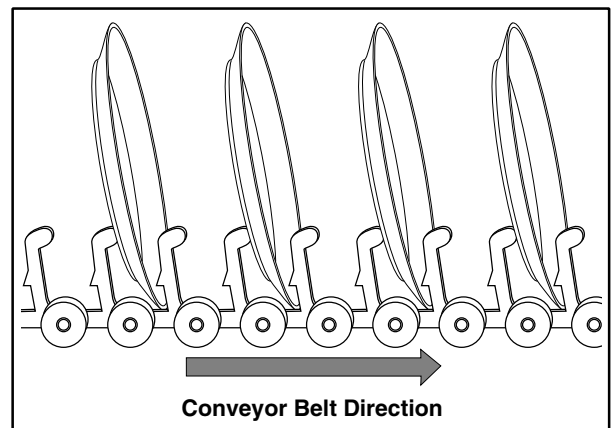

**Figure 10: Conveyor Belt Direction**

8. Fasten the rope to the center of the first lower belt connecting rod (Figure 11).
9. Station one person on the unload end of the dishwasher and one at the load end. The person at the load end will feed the Conveyor Peg Belt into the dishwasher while the person on the unload end pulls the rope until the belt reaches the unload Drive End Shaft.

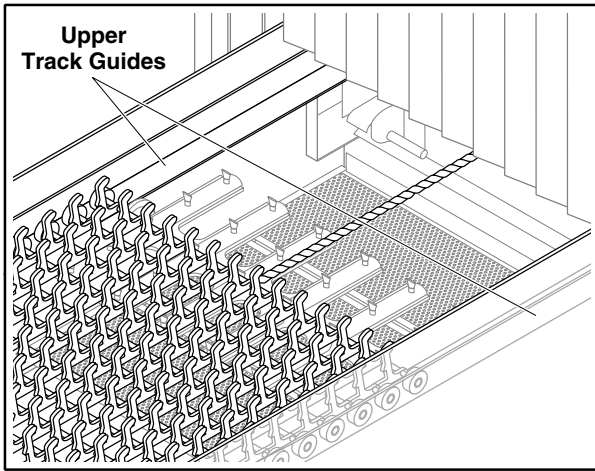

**Figure 11: Upper Track Guides**

10. Once the belt has reached the unload Drive End Shaft, place the belt on the sprockets and have the person on the load section slowly pull on the rope. This will feed the belt around the sprockets.

**NOTE:** Lift up on the Conveyor Peg Belt to make sure the belt rides on all the lower track guides while pulling it back through the dishwasher.

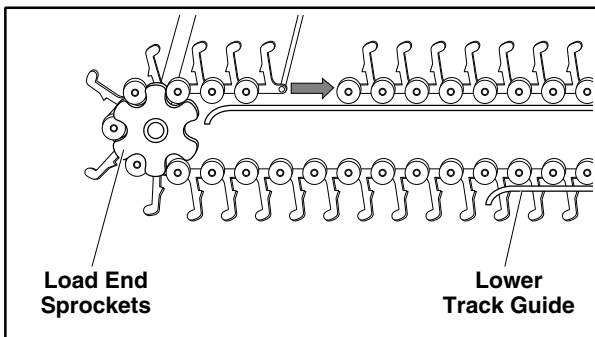

**Figure 12: Lower Track Guides**

11. Once the Conveyor Peg Belt reaches the Load End, unfasten the rope, pull the belt up and around the load end Sprockets and temporarily tie the two ends together with a tie strap or a piece of wire.

12. Now pull the belt and move the temporary tied section to the unload section where there is more room to work.

13. Remove the tie strap or piece of wire and the first lower belt rod.

14. Pull the two pieces of belt together and reassemble the lower rod matching the existing pattern.

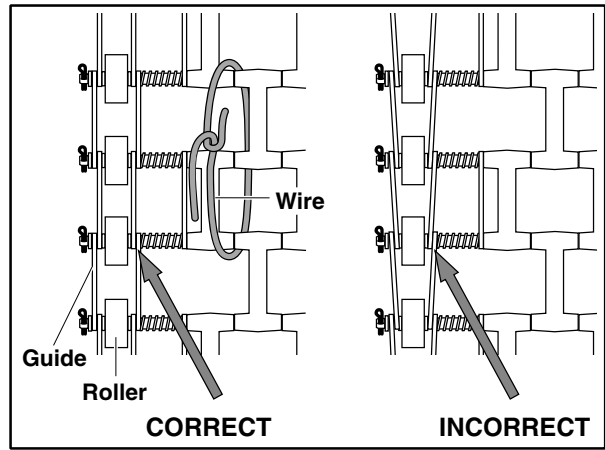

**Figure 13: Conveyor Peg Belt Assembly**

15. Once the rod has been correctly assembled, reinstall the flat washer and cotter pin.

### Conveyor Peg Belt Tension Adjustment

**NOTE:** A properly adjusted Conveyor Peg Belt will sag approximately 1" – 1-1/2" between the Lower Track Guides.

There are two (2) adjustable Take-up Bearings at the load end of the dishwasher. To adjust the Conveyor Peg Belt tension, proceed as follows:

1. Adjust the slack in the Conveyor Peg Belt by evenly tightening the Take-up Bearings located on both sides of the load section.
2. Measure the distance between the Drive End Shaft and the end of the load section on each side. The distances should be equal to ensure the Conveyor Peg Belt runs true.

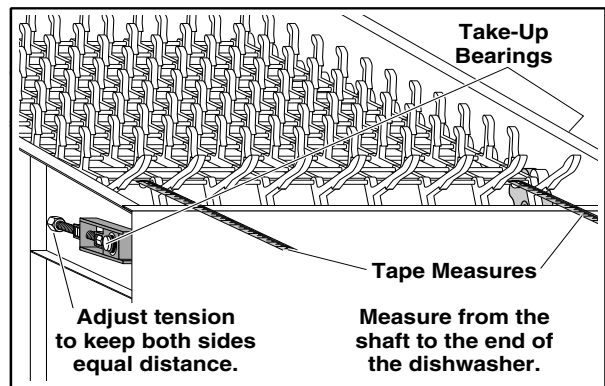
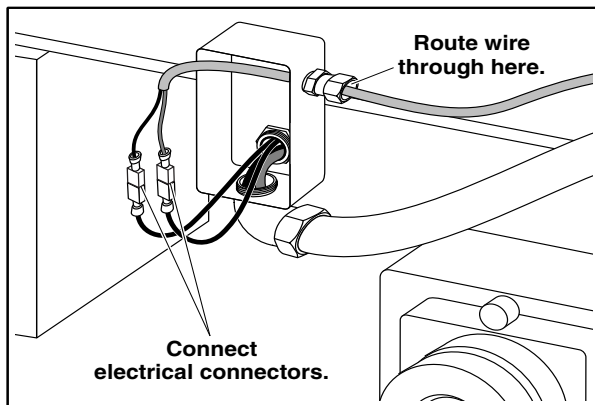

**Figure 14: Take-up Bearing Adjustment**

3. Once the Conveyor Peg Belt tension has been properly adjusted, reinstall the V-belts on the pulleys and tighten the conveyor Motor mount bolts and tension adjustment screw.
4. Set the dial for the Conveyor Speed Potentiometer in the Main Electrical Control Box to 60.
5. Make sure the Conveyor FOWARD/ REVERSE/OFF switch is in the FORWARD position.

### Conveyor Stop Bar Switch Electrical Connection

1. Route the provided electrical lead from the Reed Switch to the junction box located on the main dishwasher unload end.
2. Route the electrical lead through the junction box.
3. Connect the two (2) electrical connectors.
4. Adjust the Conveyor Stop Bar so that it swings freely.

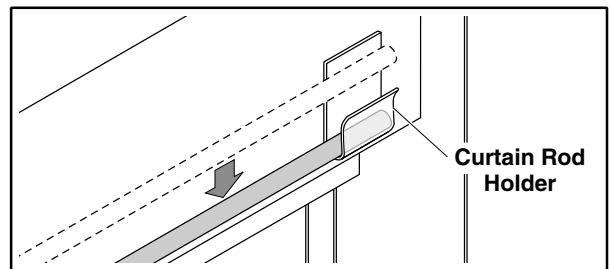

**Figure 15: Conveyor Stop Bar Switch Electrical Connection**

### Curtain Installation

Multi-flap curtains are used throughout the dishwasher to keep moisture inside and reduce the potential of hot water injury. The curtain configurations vary by model and size. Refer to the curtain placement decals located on the front of the main dishwasher hood for the exact curtain number and placement. Installation procedures are the same for all curtains.

1. Starting with the long, middle curtain, reach inside the main dishwasher compartment and locate the middle curtain rod holder.
2. Place one end of the curtain rod into its holder.



**Figure 16: Curtain Rod Holder**

3. Place the other end of the curtain rod into its holder.
4. Repeat the procedure for remaining curtains.

### VENTILATION DUCT CONNECTION (IF REQUIRED)

For units that do not require ventilation duct connections, proceed to the UTILITY CONNECTIONS section.

**NOTICE** Exhaust vent ducts should fit inside the dishwasher vents but not interfere with the operation of the dampers.

### Gas-Heated Dishwashers

**NOTE:** Infrared gas tank heat-equipped dishwashers are supplied with a stainless steel exhaust system, which terminates approximately 5.5" above the hood in the rear of the dishwasher. Do not make a sealed connection to the dishwasher exhaust stack. Refer to Figure 17 for gas dishwasher venting installation requirements.

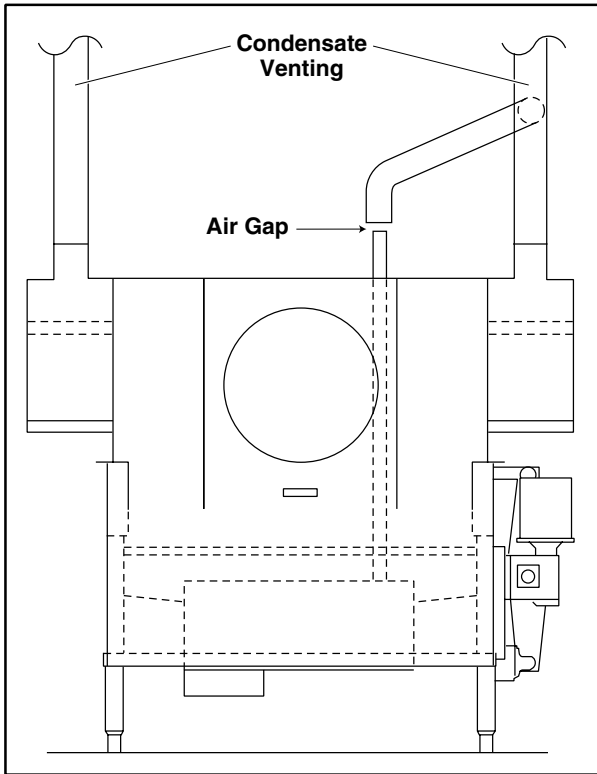

**Figure 17: Recommended Gas Venting**

### Steam or Electric-Heated Dishwashers

For all other units requiring ventilation duct connections, proceed as follows:

1. Check that the ventilation ducts are correctly positioned above the dishwasher vents.
2. Refer to the Stero Engineering Drawing for the dishwasher ventilation duct requirements and size. This drawing is located in the Main Electrical Control Box along with the electrical diagram.
3. Install the ventilation ducts to the dishwasher vents per the dishwasher duct requirements and sizing and per local and state codes.

4. Seal the duct connection joint with silicone sealant.

### Electrical Connections

The exhaust fan is connected to an electrical box located on the back of the Main Electrical Control Box, labeled as FAN CONTACTOR ENCLOSED (Figure 18). Connect the electrical connections as follows:

8. Remove the two (2) screws securing the Fan Contactor cover plate. Retain for reinstallation.
9. Remove and discard the 1/2" neoprene, watertite plug from the hole in the top of the Fan Contactor box.
10. Install a 1/2" sealtite connector to the exposed hole in the top of the Fan Contactor box.
11. Route the incoming electrical wires through the sealtite connector.
12. Connect the fan electrical wires to the contactor terminals (Figure 18).
13. Reinstall cover screws removed in step 1.

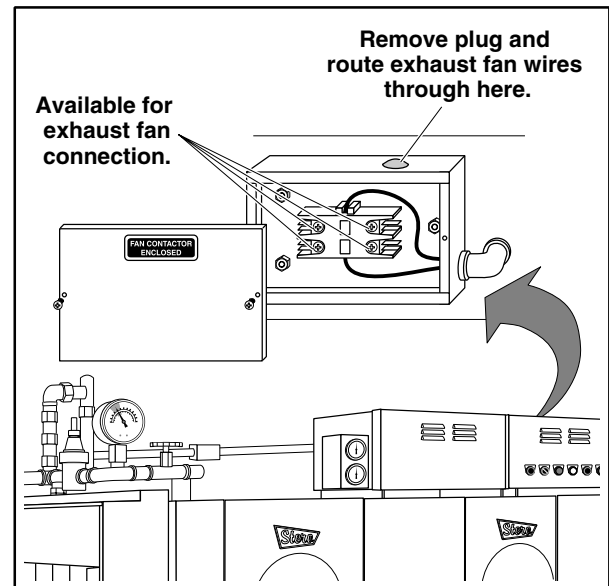

**Figure 18: Exhaust Fan Electrical Connection**

## UTILITY CONNECTIONS

### PLUMBING CONNECTIONS

#### Water Supply Connections

**NOTICE** Before connecting the water supply, it must be purged to remove any contaminants from the line.

**NOTE:** Ensure that the line strainer is installed so that iron or other metal particles cannot contaminate the dishwasher.

Refer to the Stero Engineering drawing to connect the water supply to the dishwasher connection(s) as indicated by the connection labels attached to the connection points. Proceed as follows:

1. Locate the water supply connection(s) as labeled on the dishwasher.
2. Check the incoming water temperature.
3. Connect the customer-supplied water line(s) to the appropriate connection(s).

**NOTE:** The dishwasher requires a pressure of 20 psi at the Final Rinse for correct operation (Figure 19). It may be necessary to increase the pressure (with a booster pump) or decrease the pressure (with a pressure reducing valve).

4. Check the incoming water pressure at the Final Rinse Pressure Gauge.

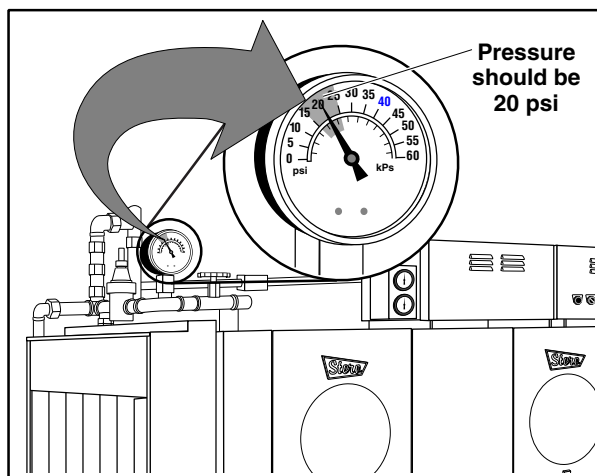

**Figure 19: Final Rinse Pressure**

#### Drain Connections

**NOTE:** Make as many clean outs as possible in the drain line, using tees with pipe plugs in each tee instead of elbows, to allow the lines to be cleaned out periodically.

Refer to the Stero Engineering drawing for the dishwasher drain requirements.

**NOTE:** In some cases, a grease trap must be fitted into the waste water line. If a grease trap is required for installation, check that it is present.

Install the Waste Drain per local and state codes.

#### Steam Connections

**NOTE:** Before connecting the steam supply, it must be purged to remove any contaminants from the line.

Refer to the Stero Engineering drawing to connect the steam supply and condensate return to the dishwasher connection(s) requirements as indicated by the connection labels attached to the dishwasher connection points. Proceed as follows:

**NOTE:** The condensate return should be gravity fed to the boiler. A return with an upward slope will require a condensation sump w/pump.

1. Check that the incoming steam pressure is 15-40 psi to meet the dishwasher pressure requirements per the Stero Engineering drawing for the dishwasher.
2. Check that the pipe size is equal to or greater than the label posted on the dishwasher connection point for proper operation per the Stero engineering drawing for the dishwasher.
3. Once the correct pressure and volume has been verified, connect the customer-supplied steam line(s) to the dishwasher steam connection(s) as indicated by the labels attached to the dishwasher's connection(s).

## GAS CONNECTIONS

### Gas Lockout/Tagout Procedure

**⚠ WARNING** All gas joints disturbed during servicing must be checked for leaks. Do not use an open flame. Use a hazardous gas tester or a soap and water solution (Bubbles indicate a gas leak).

**⚠ WARNING** Do not operate a gas fueled appliance if a gas leak is present.

The Lockout/Tagout procedure is used to protect personnel working on a gas appliance. Before performing any maintenance or service that requires gas disconnections, follow these steps:

1. Locate the gas valve or inlet.
2. Place the valve in the OFF position.
3. Place a tag on the valve indicating that service is being performed on equipment and the gas must remain off until service is complete.
4. Place a locking device on the gas valve or inlet, preventing connection until the lock is removed.
5. On the appliance, make sure all flame sources are extinguished and/or removed.
6. Bleed residual gas from the appliance inlet line and allow time for the gas to dissipate before beginning service on the appliance.

**NOTE:** Before connecting the gas supply, it must be purged to remove any contaminants from the line.

Refer to the Stereo engineering drawing to connect the gas supply to the dishwasher connection(s) as indicated by the labels attached to the dishwasher's connection(s) points. Proceed as follows:

1. Check that the pipe size of gas delivered is sufficient for proper operation. Refer to the following chart for the dishwasher incoming gas pressure requirement.

GAS TYPE	REQUIRED W.C.
Natural Gas	3+"
Liquid propane (LP)	8+"

2. Connect the customer-supplied gas line to the dishwasher gas connection(s).
3. Check the gas line(s) for leaks using a soap and water solution.

## ELECTRICAL CONNECTIONS

**⚠ WARNING** Electrical connections should be performed only by a certified professional.

**⚠ WARNING** Electrical and grounding connections must comply with the applicable portions of the National Electric Code and/or other local electrical codes.

**⚠ WARNING** UL73 grounding instructions: This appliance must be connected to a grounded, metal, permanent wiring system; or an equipment-grounding conductor must be run with the circuit conductors and connected to the equipment-grounding terminal or lead on the appliance.

**⚠ WARNING** Disconnect the electrical power to the machine and follow Lockout/Tagout procedures.

### Electrical Lockout/Tagout Procedures

Lockout/Tagout procedures are used to protect personnel working on an electrical appliance. Perform the following steps before performing any type of maintenance or service on an electrically operated appliance.

1. Lockout supply circuit breaker to the dishwasher.

2. Place a lock or other device on electrical box cover to prevent someone from placing circuit breaker ON.
3. Place a tag on electrical box cover to indicate that unit has been disconnected for service and power should not be restored until tag is removed by maintenance personnel.

### Main Electrical Supply

Refer to the Stero Engineering drawing and wiring diagram located inside the Main Electrical Control Box for the dishwasher electrical supply requirements.

To connect the main electrical supply, proceed as follows:

1. Perform the Lockout/Tagout procedures.
2. Check that the incoming power leads are of sufficient rating for the dishwasher current draw. Amperage and minimum supply wire specifications are shown on the decal located in the Main Electrical Control Box.
3. Using the Stero Engineering drawing and wire diagram for reference, install the power lines to the incoming distribution terminals.

4. Connect the ground wire to the ground terminal marked GRD.

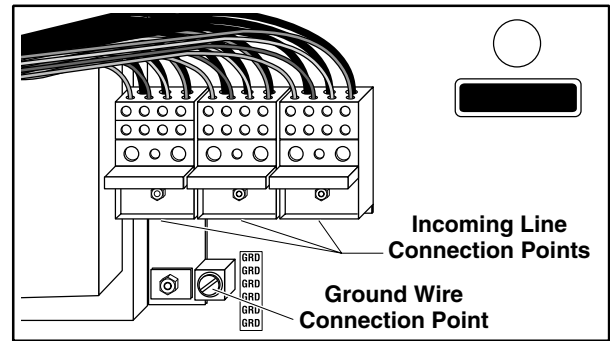

Figure 20: Main Electrical Connection

### Chemical Supply Connections

Once the dishwasher has been installed and all utility, electrical, plumbing and ventilation connections have been made, connect the chemical supply connections to the junction box located on the rear of the Main Electrical Control Box.

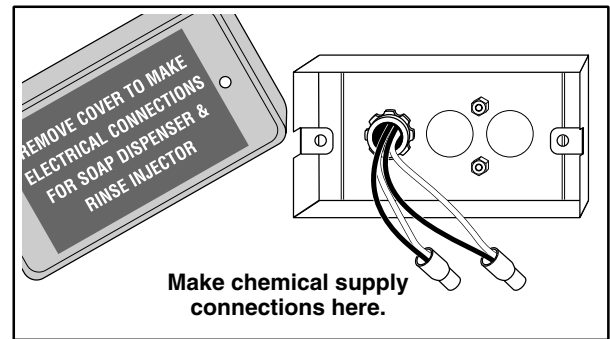

Figure 21: Chemical Supply Connection

# ADJUSTMENTS AND TESTS

## PUMP MOTOR CHECK

After all electrical connections have been made, check to ensure the pump motor is turning in the proper direction. To check the motor's direction, perform the following:

1. Close the Drain Valve Foot levers for all the tanks.
2. Turn the main power to the dishwasher ON.
3. On the Main Electrical Control Box, turn the SAFETY Switch to the ON position.
4. If so equipped, depress the RESET button located on the Main Electrical Control Box.
5. Press the FILL button to fill the dishwasher with water.

**NOTE:** The Conveyor Peg Belt will start from any START Switch located on the dishwasher.

6. When the dishwasher stops filling with water, depress the START Switch.
7. Check that the pumps are running in the correct direction per the arrow decals attached to the pumps.
8. Proceed as follows:
  - a. If the rotation direction is correct, turn the SAFETY Switch to the OFF position.
  - b. If the rotation is reversed:
    1. Turn the SAFETY Switch to the OFF position.
    2. Perform the ELECTRICAL LOCKOUT/TAGOUT procedure.
    3. Gain access to the main power incoming electrical leads in the mounted circuit breaker box.
    4. Disconnect and reverse any two of the incoming power wires on the distribution block.
    5. Secure all electrical connections and access panels.
    6. Repeat steps 2 through 7 to verify the pumps are rotating in the correct direction before proceeding.

## CONVEYOR BELT TENSION CHECK

**NOTE:** Properly adjusted V-belts should slip on the pulleys when a reasonable amount of force is applied (approximately 100 pounds) against the conveyor peg belts travel.

Check Conveyor Peg Belt tension as follows:

1. While positioned at the load section, CAREFULLY try to stop the belt with both hands while the Conveyor Peg Belt is in motion.
2. Proceed as follows:
  - a. If an excessive amount of force is required or if the belt would not slip when force is applied against the Conveyor Peg Belt travel, proceed to V-BELT TENSION ADJUSTMENT.
  - b. If a minimal amount of force was required or if the belt would not rotate at all, proceed to V-BELT TENSION ADJUSTMENT.
  - c. If the Conveyor Peg Belt slips when a reasonable amount of force is applied against it (approximately 100 lbs), the V-belt tension is properly adjusted. Perform the following:
    1. Turn the SAFETY Switch to the OFF position or press the STOP button.
    2. Reinstall the load end access panels, table and enclosure panels removed during the INSTALLATION section.
    3. Reinstall the unload end access panels, table and enclosure panels removed during the INSTALLATION section.
    4. Reinstall the main dishwasher section access panels, water line and enclosure panels removed during the INSTALLATION section.

## V-BELT TENSION ADJUSTMENT

Adjust the tension as follows:

1. Perform the ELECTRICAL LOCKOUT/TAGOUT procedure.
2. Turn the SAFETY Switch to the OFF position or press the STOP button.
3. Loosen the two (2) Conveyor Motor mount bolts just enough so that the mounting plate will slide back and forth freely.

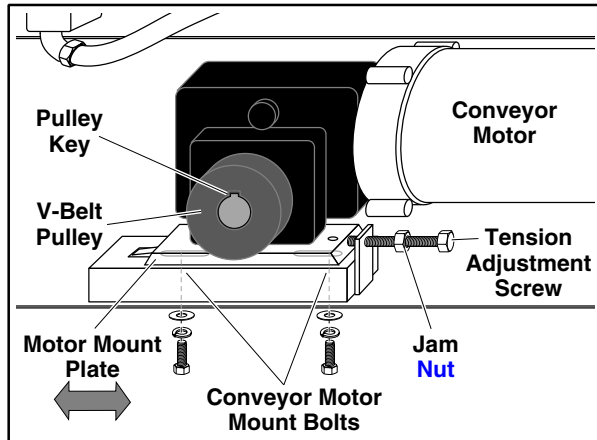

**Figure 22: Conveyor Motor V-Belt Tension Adjustment**

4. Loosen the tension adjustment jam nut and turn the threaded tension adjustment screw in or out until the belt is properly tensioned.
5. Perform the CONVEYOR BELT TENSION CHECK steps 1-5.
6. When the Conveyor Peg Belt tension has been properly adjusted perform the following:
  - a. Tighten the Conveyor Motor mount bolts.
  - b. Tighten the Tension Adjustment jam nut until it contacts the Conveyor Motor mount plate.
  - c. Turn the SAFETY Switch to the OFF position or press the STOP button.
  - d. Reinstall the load end access panels, table and enclosure panels removed during the INSTALLATION section.
  - e. Reinstall the unload end access panels, table and enclosure panels removed during the INSTALLATION section.
  - f. Reinstall the main dishwasher section access panels, water line and enclosure panels removed during the INSTALLATION section.

# OPERATION

## OPERATING CONTROLS LOCATION

The operating controls for the dishwasher are located in a stainless steel Main Electrical Control Panel, which is mounted on top of the dishwasher. Stero offers two different types of dishwasher controls. The two types of controls are:

- Push Button Control Box
- LCD Control Box

### Push Button Control Box

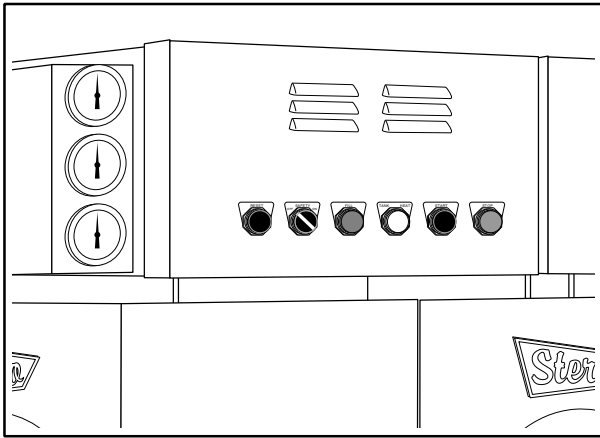

**Figure 23: Operating Controls Location**

- SAFETY Switch
- FILL Button
- HEAT Button
- START Button
- STOP Button
- Optional BOOSTER HEAT Button
- Optional RESET Button

### LCD Control Box

The LCD Control Panel consists of the following controls, which are explained in the OPERATING CONTROLS FUNCTION section of this manual:

- Power ON/OFF switch
- LCD Display screen

- START button
- STOP button
- FILL button
- HEAT button
- ALARM MUTE button
- BOOSTER HEAT button

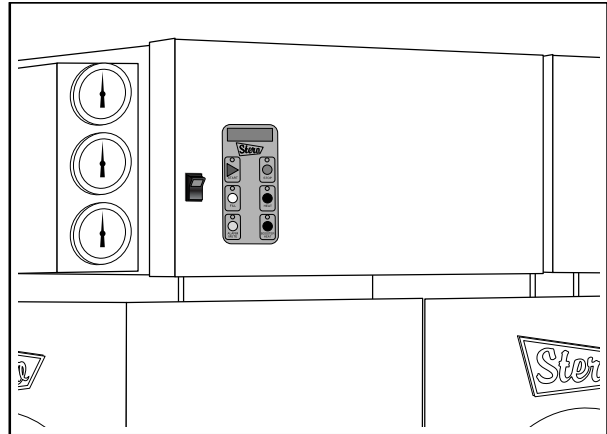

**Figure 24: LCD Panel Operating Controls Location**

Also located on top of the dishwasher are the temperature gauges. When the pumps are running, the temperature gauges give a visual indication of the actual water temperatures within each section of the dishwasher. The gauges are clearly labeled and, depending on model and type, are for the following sections:

- Scrap Tank Water Temperature
- Wash Tank Water Temperature
- Rinse Tank Water Temperature
- Final Rinse Water Temperature
- Auxiliary Rinse Water Temperature

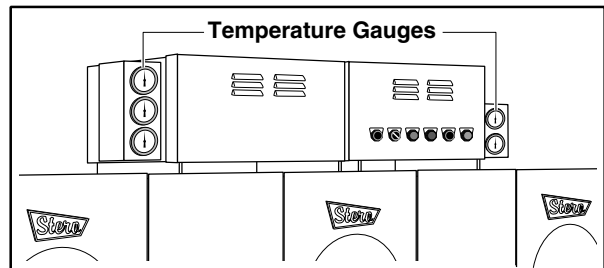

**Figure 25: Temperature Gauge location**

## OPERATING CONTROLS FUNCTION

### Push Button Control Box

#### SAFETY Switch

The SAFETY Switch energizes the dishwasher electrical circuit when placed ON. The SAFETY Switch is located on the Main Electrical Control Box.

#### FILL Button

The FILL button energizes the Fill valves to fill the tanks with water. The FILL button is located on the Main Electrical Control Box.

#### HEAT Button

The HEAT button energizes the dishwasher heating circuit. The HEAT button is illuminated when the tank heat is turned on and the tanks are full. The HEAT button is located on the Main Electrical Control Box.

#### START Button

The START button energizes the electrical pumps and Conveyor Peg Belt. The START button is located on the Main Electrical Control Box.

#### STOP Button

The STOP button stops the conveyor belt and pumps. The STOP button is located on the Main Electrical Control Box.

#### BOOSTER HEAT Button

The BOOSTER HEAT button is only present on units pre-wired with a Stero steam Booster Heater. The BOOSTER HEAT button energizes the Booster Heater control circuit. The BOOSTER HEAT button if pre-wired by Stero will be located on the Main Electrical Control Box.

#### RESET Button

The RESET button is only present on gas-heated dishwashers. The RESET button resets the electrical control circuit in the event of a power outage or interruption. The RESET button is located on the Main Electrical Control Box.

### LCD Control Box

#### Power ON/OFF Switch

The Power ON/OFF switch turns the Control Module ON and OFF. The Power ON/OFF switch is located on the front of the dishwasher above the doors and near the Control Panel Keypad.

#### LCD Display Screen

The LCD Display screen displays the current status or Fault Condition Code for the dishwasher. The LCD Display screen is located on the top section of the Control Panel Keypad.

#### START Button

The START button energizes the dishwasher RUN cycle. The START button is located on the Control Panel Keypad.

#### STOP Button

The STOP button stops the conveyor and the pumps. The STOP button is located on the Control Panel Keypad.

#### FILL Button

The FILL button energizes the Fill valves to fill the tanks with water. The FILL button is located on the Control Panel Keypad.

#### HEAT Button

The HEAT button energizes the dishwasher heating circuit. The HEAT button is located on the Control Panel Keypad.

#### ALARM MUTE Button

The ALARM MUTE button silences the audible alarm when a fault condition occurs. The ALARM MUTE button is located on the Control Panel Keypad.

#### BOOSTER HEAT Button

The BOOSTER HEAT button is only operational for dishwashers with an optional Booster Heater installed. The BOOSTER HEAT button energizes the Booster control circuit. The BOOSTER HEAT button is located on the Control Panel Keypad.

## RUN CYCLE

### Push Button Control Box

To complete a run cycle for a dishwasher equipped with push button controls, perform the following.

**⚠ WARNING** Water temperature inside the dishwasher can reach 190°F and cause severe burns.

1. Turn the Drain Valve Foot lever(s) for all tanks to the SHUT position.
2. Ensure all curtains are properly installed.
3. Ensure all Strainer Pans are properly installed.
4. Ensure all Spray Manifolds are properly installed and that the end caps are tight.
5. Close all of the doors to the dishwasher. The doors have a safety switch that will prevent the dishwasher from running with doors open.
6. Turn the main power supply to the dishwasher ON.
7. If the dishwasher is gas-heated, depress the RESET button.
8. Turn the SAFETY Switch to the ON position.
9. Push the FILL button. The FILL button will illuminate until the tanks fill to the proper level (between 1" and 2" below the Overflow.)
10. Push the HEAT button. The HEAT button will illuminate to indicate the heating circuit is energized. Allow the tanks to heat to the proper operating temperature (approx. 15-30 minutes).
11. For dishwashers equipped with an optional steam Booster Heater, push the BOOSTER HEAT button. The Booster Heater will begin to heat.
12. Push the START button located on the Main Electrical Control Box. This will start the dishwasher wash pumps and the Conveyor Peg Belt.

**NOTE:** The pumps and Conveyor Peg Belt will start from any START switch located on the dishwasher. When the dish rack trips the Final Rinse Rake, the Shutdown Timer will reset.

13. Place soiled ware on the Conveyor Peg Belt. The ware will convey through the dishwasher. The Conveyor Peg Belt will stop when the ware reaches the Conveyor Stop Bar Switch or when the Shutdown Timers time expires.
14. To restart the conveyor, remove the clean ware from the Conveyor Peg Belt. The belt will restart automatically.

### LCD Control Box

To complete a RUN cycle for a dishwasher equipped with an LCD Control Box, perform the following.

**⚠ WARNING** Water temperature inside the dishwasher can reach 190°F and cause severe burns.

1. Turn the Drain Valve Foot lever(s) for all tanks to the SHUT position.
2. Make sure all Strainer Pans are clean and secured in place.
3. Make sure all Upper and Lower Spray Manifolds are securely in place and all end caps are tight.
4. Make sure all curtains are clean and securely in place.
5. Close all of the doors to the dishwasher. The doors have a safety switch that will prevent the dishwasher from running with doors open.
6. If the dishwasher is gas-heated, depress the RESET button.
7. Turn the Power Switch to the ON position. The Control Panel Keypad LCD will display INITIALIZING for 30 seconds.
8. When the Control Panel Keypad LCD displays HOT WATER SANITIZER, press the FILL button located on the Control Panel Keypad.

9. When the Control Panel Keypad LCD displays READY, press the HEAT button located on the Control Panel Keypad.

**NOTE:** The BOOSTER HEAT button is only operational for dishwashers equipped with an optional Booster Heater.

10. If equipped, press the optional BOOSTER HEAT button located on the Control Panel Keypad. This will preheat the water in the Booster Tank for approximately 10 minutes or until operating temperatures have been reached.
11. Press the START button located on the Control Panel Keypad to start the wash cycle.

**NOTE:** Final rinse temperature and flow pressure gauges are accurate only when a rack enters the final rinse area and water is flowing. Acceptable temperature range is 180°F-195°F and pressure should be 20 psi.

**NOTE:** Wash dishes in batches to conserve energy, water and soap.

**NOTE:** A Conveyor Stop Bar Switch mounted on the unload section will stop the belt and prevent a jam. Remove dish racks before they reach and open the Conveyor Stop Bar Switch.

12. At the end of the shift, turn the Power Switch located on the Control Panel Keypad to the OFF position.
13. Turn the Drain Valve Foot levers to OPEN for all the tanks to drain the dishwasher.
14. Refer to the CLEANING section of the Installation and Operation manual for cleaning procedures.

## SHUTDOWN

### Daily Shutdown

At the end of each shift or washing period, the following steps will ensure proper results from your Stero dishwasher.

1. Shut off all power to the dishwasher, place the SAFETY Switch to the OFF position or turn the power switch to the OFF position.
2. Turn the Drain Valve Foot Lever(s) for all tanks to the OPEN position.
3. Open all the doors.
4. If applicable, perform the SCRAPPER SPRAY MANIFOLD REMOVAL procedure.
5. Perform the TREE-TYPE SPRAY MANIFOLD REMOVAL Procedure.
6. Perform the CURTAIN REMOVAL Procedure.
7. Perform the STRAINER PAN REMOVAL Procedure.

**NOTE:** The Spray Manifolds, Strainer Pans and Curtains should be taken to a sink and cleaned as per the procedures in the CLEANING section.

8. Perform the dishwasher Interior Cleaning Procedure.
9. Perform the Exterior Cleaning Procedure.
10. Install the Spray Manifolds, reversing the Tree-Type Spray Manifold Removal Procedure.
11. Install the Strainer Pans, reversing the Strainer Pans Removal Procedure.
12. Install the Curtains, reversing the Curtain Removal Procedure.
13. Leave all doors open to allow the interior of the dishwasher to air dry.
14. Turn the circuit breakers to OFF.

# MAINTENANCE

## PARTS REMOVAL

### Scrapper Spray Manifold Removal

1. Perform the DAILY SHUTDOWN Procedure on page 23, steps 1 through 3.
2. Locate the Mounting Clamp Handle or Hand Grip Clamp located at the front of the Scrapper Spray Manifold.

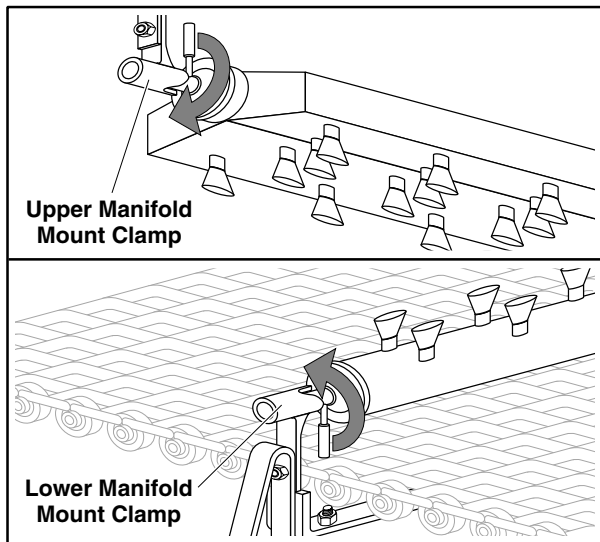

**Figure 26: Scrapper Spray Manifold Mount Clamp**

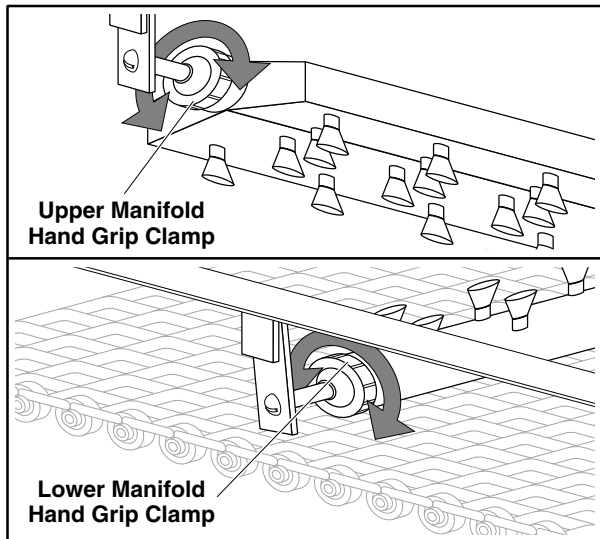
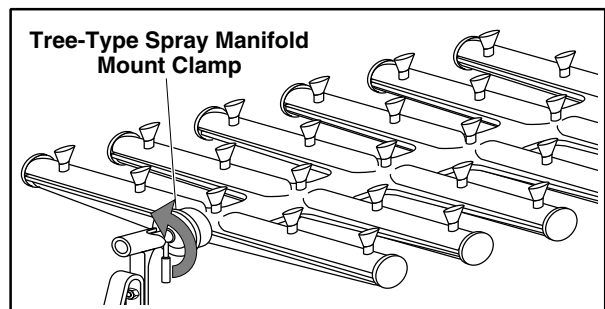

**Figure 27: Scrapper Spray Manifold Hand Grip Clamp**

3. While holding onto the Scrapper Spray Manifold either:
  - a. Rotate the mounting clamp handle counterclockwise to release the Scrapper Spray Manifold (Figure 26).
  - b. Unscrew the Manifold Hand Grip Clamp to loosen the Scrapper Spray Manifold (Figure 27).
4. Slide the Scrapper Spray Manifold assembly toward the front of the dishwasher to disengage it from the rear water line connection.
5. Carefully pull the Scrapper Spray Manifold out of the dishwasher.
6. Repeat the procedure for the Lower Scrapper Spray Manifold assembly.
7. Refer to CLEANING section for procedures to clean the Scrapper Spray Manifolds.
8. When the Scrapper Spray Manifold has been cleaned, install by reversing the above steps.

### Tree-Type Spray Manifold Removal

1. Perform the DAILY SHUTDOWN Procedure on page 23, steps 1 through 3.
2. Locate the Mounting Clamp Handle or Hand Grip Clamp located at the front of the Spray Manifold.



**Figure 28: Tree-Type Spray Manifold Mounting Clamp Handle**

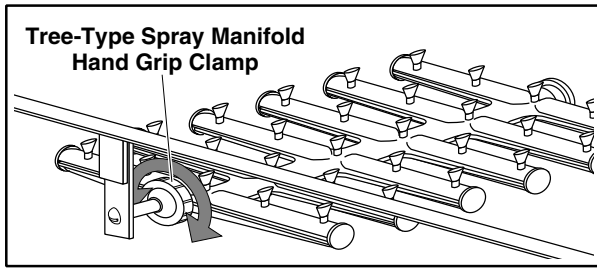

**Figure 29: Tree-Type Spray Manifold Hand Grip Clamp**

3. While holding onto the Spray Manifold either:
  - a. Rotate the Mounting Clamp handle counterclockwise to release the Spray Manifold (Figure 28).
  - b. Unscrew the Manifold Hand Grip clamp to loosen the Spray Manifold (Figure 29).
4. Slide the Spray Manifold assembly toward the front of the dishwasher to disengage it from the rear water line connection.
5. Carefully pull the Spray Manifold out of the dishwasher.
6. Repeat the procedure for the remaining Spray Manifold assemblies.
7. Refer to the CLEANING section for procedures to clean the Spray Manifolds.
8. When the Spray Manifolds have been cleaned, install by reversing the above steps.

**Curtain Removal**

Curtain configurations vary depending on model. Refer to the curtain placement decals for correct curtain placement. Removal procedures are the same for all curtains.

1. Perform the DAILY SHUTDOWN Procedure on page 23, steps 1 through 5.
2. Reach inside to locate the top of the curtain rod end.
3. Lift one end of the curtain rod up and out of its holder.
4. Locate the other end of the curtain rod and lift it out of its holder.
5. Carefully remove the rod and curtain from the washer.

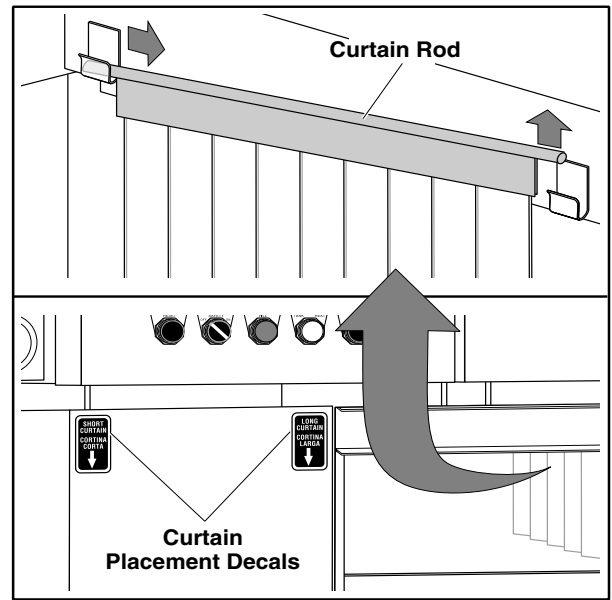

**Figure 30: Curtain Removal**

6. Repeat this process until all curtains and rods have been removed.
7. Refer to the CLEANING section for curtain cleaning procedures.
8. To install the curtains, reverse above steps.

**Strainer Pan Removal**

**NOTE:** The interior of the dishwasher should be cleaned before removing the Strainer Pans.

1. Perform the TREE-TYPE SPRAY MANIFOLD REMOVAL procedure to remove the Lower Spray Manifolds.

**NOTICE** The Strainer Pans are set atop the wash and the rinse tanks. Do not allow the collected material to spill from the Strainer Pans into the water tanks.

**NOTE: The Strainer Pans for the Scrapper Tank are installed with the perforated side up to allow the food soil to wash into the outboard scrap basket. The wash and rinse Strainer Pans are installed with their perforated sides down to collect the food soil.**

2. Remove the loose soil from all the tank Strainer Pans.
3. Carefully lift and remove all the Strainer Pans from the dishwasher.

## FLIGHT TYPE DISHWASHERS

4. The Strainer Pans should be thoroughly cleaned in a sink before reinstalling back into the dishwasher.
5. To install the Strainer Pans, reverse the above steps.

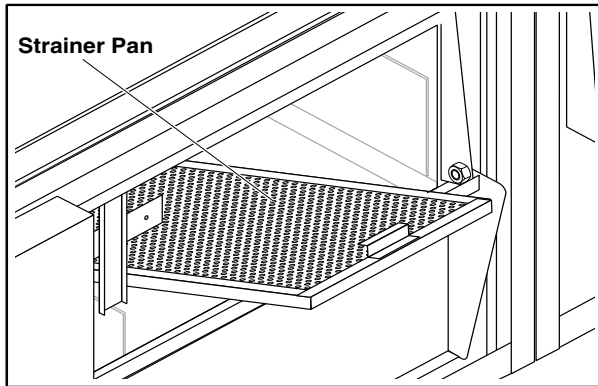

**Figure 31: Strainer Pans Removal**

## CLEANING

**NOTICE** Never use any metal tools. Scrapers, files, wire brushes or scouring pads (except for stainless steel scouring pads), will mar the surface!

**NOTICE** Never use steel wool, which will leave behind particles that can rust!

**NOTICE** Never use acid-based or chloride-containing cleaning solutions, which will break down the protective film!

**NOTICE** Never rub in a circular motion!

**NOTICE** Never leave any food products or salt on the surface. Many foods are acidic. Salt contains chloride!

### Interior

This procedure should be performed based on a schedule pre-determined for your operation.

1. Perform the DAILY SHUTDOWN Procedure steps 1 through 8.
2. Wash the interior compartment of the dishwasher with a solution of mild detergent and warm water.

3. Remove any food particles that might remain between the drain valve and the seat.
4. Rinse the interior of the dishwasher with warm water and flush food soil through the floor drains.
5. Leave the doors open and allow the interior to air dry.

### Spray Manifolds (Tree-Type and Scrapper)

All the Spray Manifold assemblies should be thoroughly cleaned before reinstalling in the dishwasher. To clean the Spray Manifolds, perform the following:

1. Perform the DAILY SHUTDOWN Procedure steps 1 through 7.
2. Take the Spray Manifolds to a sink and thoroughly wash them with a solution of mild detergent and warm water.
3. Clean out the Spray Manifold spray nozzles with a paper clip to remove any collected food particles.
4. Rinse the Spray Manifolds thoroughly.

### Curtains

It is essential that the dishwasher curtains be cleaned daily. To clean the dishwasher curtains, perform the following:

1. Perform the DAILY SHUTDOWN Procedure steps 1 through 6.
2. Take all the curtains and rods to a sink.
3. Thoroughly clean the curtain flaps with a solution of mild detergent and warm water.
4. Clean between the curtain flaps with a fiber bristled brush.
5. Thoroughly rinse the curtains.
6. Allow the curtains to air-dry before installing into the dishwasher.

### Exterior

Clean the floor area around and underneath the dishwasher to prevent soil accumulation.

## STAINLESS STEEL CARE

### Cleaning

Stainless steel contains 70–80% iron, which will rust if not properly maintained. It also contains 12–30% chromium, which forms an invisible passive, protective film that shields against corrosion. If the film remains intact, the stainless steel will remain intact. However, if the film is damaged, the stainless steel can break down and rust. To prevent stainless steel breakdown, follow these steps:

**NOTICE** Never use any metal tools. Scrapers, files, wire brushes or scouring pads (except for stainless steel scouring pads), will mar the surface!

**NOTICE** Never use steel wool, which will leave behind particles that can rust!

**NOTICE** Never use acid–based or chloride–containing cleaning solutions, which will break down the protective film!

**NOTICE** Never rub in a circular motion!

**NOTICE** Never leave any food products or salt on the surface. Many foods are acidic. Salt contains chloride!

For routine cleaning, use warm water, mild soap or detergent and a sponge or soft cloth.

For heavy–duty cleaning, use warm water, a degreaser and a plastic, stainless steel or Scotch–Brite pad.

Always rinse thoroughly. Always rub gently in the direction of the steel grain.

### Preserving and Restoring

Special stainless steel polishing cleaners can preserve and restore the protective film.

Preserve the life of stainless steel with a regular application of a high quality stainless steel polishing cleaner as a final step to daily cleaning.

If signs of breakdown appear, restore the stainless steel surface. First, thoroughly clean, rinse and dry the surface. Then, on a daily basis, apply a high–quality stainless steel polish according to manufacturer’s instructions.

### DELIMITING

Contact your Chemical Supplier for Delimiting chemicals and procedures.

# TROUBLESHOOTING

## LCD DISPLAY MESSAGES

The Control Panel Keypad LCD (Figure 24) displays operational and fault information needed to RUN the dishwasher. The following table lists the display message text, when the display messages occur, what each display message means and how to correct a fault, if needed.

DISPLAY MESSAGE	WHEN THE DISPLAY OCCURS	OPERATING OR FAULT CONDITION	CORRECTIVE ACTION
INITIALIZING	During the first 30 seconds after the Power Switch is turned ON	Normal operation while system is initializing.	Normal operation None required.
HOT WATER SANITIZER	Before the Fill operation is completed	Normal operation starts 30 seconds after the Power Switch is pressed ON.	Normal operation None required.
READY	After the Fill operation is completed	Normal operation indicates all of the tanks are full.	Normal operation None required.
RUN CYCLE	When the wash cycle is started	Normal operation indicates the dishwasher is washing dishes.	Normal operation None required.
DOOR OPEN	When a door is open	Indicates the door is open and needs to be closed for normal operation to resume.	Close the dishwasher door.
CLEAR TABLE LIMIT SWITCH	When the Conveyor Stop Bar Switch is closed due to a backup of clean dishes	Indicates clean dish racks need to be removed from the unload section.	Remove dish racks from the unload section. The Conveyor Stop Bar Switch will reset when racks are removed.
NO HEAT/ RESET THERMOSTAT	When the High-Temperature Limit Cutoff switch is opened and an alarm buzzer is sounding. <b>NOTE:</b> To turn the alarm buzzer OFF before the alarm condition is removed, press the ALARM MUTE button on the keypad	Indicates the internal temperature has exceeded the high limit.	Turn the SAFETY Switch to the OFF position. Reset the tripped High Limit Cutoff Switch by pressing the red red reset button located on the tank thermostat in.

<b>DISPLAY MESSAGE</b>	<b>WHEN THE DISPLAY OCCURS</b>	<b>OPERATING OR FAULT CONDITION</b>	<b>CORRECTIVE ACTION</b>
LOW WATER LEVEL	When one or both water level switches are opened	Indicates the water level in the wash or rinse tanks has dropped below the operating level for more than five seconds.	Drain and refill the tanks.

### OPERATIONAL TROUBLESHOOTING

The following table lists common operator permitted troubleshooting remedies. If the remedy does not correct the symptom, shut down the dishwasher and contact your local factory-authorized Stero service professional.

<b>SYMPTOM</b>	<b>POSSIBLE CAUSE</b>	<b>REMEDY</b>
Pump motor starts then stops.	Spray Manifolds are clogged.	Remove and clean the Spray Manifolds per the CLEANING section of this manual.
Conveyor will not operate.	Conveyor Stop Bar is not in the correct position.  Circuit breaker(s) are open.	Check that the Conveyor Stop Bar is in the down position.  Close the circuit breaker(s).
Dishwasher runs for a few seconds then shuts off.	Drain valve is open.	Close the drain valve.
Dishwasher is not washing properly.	The Spray Manifolds are plugged.  Detergent container is empty.  Low water level in dishwasher tank.	Remove and clean the Spray Manifolds per the CLEANING section of this manual.  Contact your detergent provider.  Wait for the water level to refill.
Dishwasher is not rinsing properly.	Final rinse sprayers are plugged.	Shut down the dishwasher and call your local factory-authorized Stero service professional.

**FLIGHT TYPE DISHWASHERS**

<b>SYMPTOM</b>	<b>POSSIBLE CAUSE</b>	<b>REMEDY</b>
Dishwasher will not come up to temperature. (ELECTRIC TANK HEAT)	Circuit breaker is tripped.	Reset circuit breaker.
	HEAT switch is OFF.	Turn HEAT switch to ON.
Dishwasher will not come up to temperature. (STEAM TANK HEAT)	Steam supply valve is closed.	Open the steam supply valve.
	Steam return valve is closed.	Open the steam return valve.
Final rinse will not come up to temperature. (STEAM BOOSTER)	Steam supply valve is closed.	Open the steam supply valve.
	Steam return valve is closed.	Open the steam return valve.
Dishwasher will not fill.	Water supply valve is closed.	Open the water supply valve.
	Open drain valve.	Check drain for food particles, misaligned or broken o-ring gasket.
Dishwasher will not hold water.	Food particles in the drain valve	Check and remove food particles from drain valve seat.
Dishwasher overfills.		Contact your local factory authorized Stero service professional.
Dishwasher will not start.	Control circuit breaker is tripped.	Reset control circuit breaker.
	SAFETY switch is in the OFF position.	Turn SAFETY switch to the ON position.
	Low water level in the tanks	Check the water level in the tanks. Water should be 1/2" below the overflow.
	Drain valve is open.	Check valve for food particles, misaligned or broken o-ring gasket.

## PRODUCT SUPPORT AND SERVICE

To obtain service and parts information concerning this model, contact the Stero authorized service provider in your area (refer to our website, [www.stero.com](http://www.stero.com), for a complete listing of authorized service and parts locations).

When calling for service, the following information must be available:

- Model Number: \_\_\_\_\_
- Serial Number: \_\_\_\_\_
- Voltage: \_\_\_\_\_

## STERO WARRANTY

This warranty is in lieu of all other warranties, expressed or implied, including without limitation any implied warranty of merchantability, fitness for a particular purpose or non-infringement, and of any other obligation or liability on the part of Stero, whether in contract, strict liability, tort or otherwise.

The Stero Company warrants this equipment to be free from defects in material and workmanship, under normal use and operation, for a period of one (1) year from the date of initial start up or eighteen (18) months from the date of shipment from the factory, whichever comes first. This warranty is conditioned upon the customer's maintenance and care as outlined in the service manual and upon return of the warranty registration card. Repairs will be performed during Stero's authorized service agency's normal business hours. If the customer requires after hours service, the customer will be responsible for the overtime premium.

Machine is warranted only for the initial place of installation. Removal of machine automatically terminates the warranty. Stero shall have no liability under this warranty unless the customer promptly notifies Stero or its factory authorized service agent of any alleged defects. All defective parts become the property of Stero and must be returned to Stero, or its agent, at Stero's expense, within thirty (30) days from the date of the part's replacement. Parts replaced within the warranty carry only the unexpired portion of

the machine's warranty. Not covered by this warranty are changes (parts and/or labor) necessitated by or damage resulting from: water conditions, accident, alteration, improper use, abuse, tampering, improper installation, or failure to follow operating and maintenance procedures. Examples of the foregoing, but without limitations are: (1) Damage to the machine resulting from excessive concentrations of chlorine or de-liming acid solutions; (2) Use with utility service other than designated on the rating plates; (3) Improper connection to utility service; (4) Inadequate or excessive water and/or steam pressure; (5) Leaks caused by faulty installation; (6) Component failures caused by water leaks due to faulty installation; (7) Failure to comply to local building codes; (8) Failures due to deposits resulting from water or steam conditions, detergents, chemicals, or improper cleaning; (9) Resetting breakers, overloads, or safety thermostats; (10) Adjustments of thermostats after 90 days of operation; (11) Improper opening of utility supply valves; (12) Cleaning drain valves, line strainers, rinse nozzles, etc.; (13) Improper installation or malfunction of chemical dispensing equipment supplied by others; and (14) Failure to provide regular maintenance and daily cleaning as outlined in the service manual. In no event will Stero be liable for loss or damage to or loss of use of facilities or other property, additional labor costs, loss of revenue, loss of anticipated profits, or other damages of any kind what-so-ever, whether direct, indirect, incidental or consequential.

**⚠ WARNING** If not installed, operated and maintained in accordance with the manufacturer's instructions, this product could expose you to fuel or fuel combustion substances, which can cause death or serious illness and which are known to the State of California to cause cancer, birth defects or other reproductive harm.

The State of California enacted the California Safe Drinking Water and Toxic Enforcement Act of 1986, (Prop. 65), which "prohibits any person in the course of doing business from knowingly and intentionally exposing any individual to a chemical known to the State of California to cause cancer or reproductive toxicity without first giving clear and reasonable warning to such individuals." The Governor's Scientific Advisory Panel added carbon monoxide to the list of hazardous chemicals known to cause reproductive harm.

In order to establish full compliance with Proposition 65, an orange warning label has been attached to each gas-fired unit manufactured by Stero.

Carbon monoxide would not be present in concentrations that would pose a "significant risk" to the consumer when the equipment is installed, operated and maintained as follows:

1. Installed in accordance with all local codes, or in the absence of local codes, with the current National Fuel Gas Code ANSI Z223.1 Latest Addenda.

2. Installed under a properly designed and operating exhaust hood.
3. Connected to the type of gas for which the unit is equipped.
4. Proper appliance pressure regulator installed on the gas supply line and adjusted for the manifold pressure marked on the rating plate.
5. Adequate air supply to the unit.
6. The equipment is operated in the manner intended and using the proper utensil for that type of appliance.
7. Keep the equipment clean and have it checked periodically.
8. Burner air adjustments, mechanical maintenance and repairs must be performed by qualified service personnel.

If the equipment is not installed, operated and maintained in accordance with the above requirements, concentrations of carbon monoxide in excess of the established limits could be present in the kitchen environment.

**ALL PERSONNEL IN THE WORKPLACE WHO MAY BE SUBJECT TO ANY EXPOSURE OF CARBON MONOXIDE MUST BE WARNED OF SUCH POSSIBLE EXPOSURE. THIS WARNING SHOULD BE CONVEYED IN A MANNER SO THAT IT IS CLEARLY UNDERSTOOD BY THE EMPLOYEE. THE EMPLOYEE MUST BE ASKED IF IN FACT HE OR SHE UNDERSTANDS THE CORRECT METHOD OF OPERATION OF THE EQUIPMENT AND THAT A RISK OF EXPOSURE EXISTS IF THE EQUIPMENT IS OPERATED IMPROPERLY.**



3200 LAKEVILLE HWY.  
PETALUMA, CA 94954  
Telephone: 800-762-7600  
Fax: 707-762-5036



Stero, a division of Illinois Tools Works Inc.  
 3200 Lakeville Highway  
 Petaluma, CA 94954-5675  
 Phone: (800) 762-7600  
 (707) 762-0071  
 Fax: (707) 762-5036

**New Equipment Performance and Installation Inspection Report**

Date: \_\_\_\_\_

**Customer Information**

Location _____	Contact Name _____
Address _____	City _____ State _____
Phone _____	Fax _____ Zip _____

**Service Agency Information**

Company \_\_\_\_\_ Technician Name \_\_\_\_\_

City \_\_\_\_\_ State \_\_\_\_\_ Zip \_\_\_\_\_ Phone \_\_\_\_\_

**Equipment Information**

Model \_\_\_\_\_ Serial Number \_\_\_\_\_ V \_\_\_\_\_ Ph \_\_\_\_\_

Date of Installation \_\_\_\_\_ Steam-Heated \_\_\_\_\_ SWB Gas-Heated \_\_\_\_\_ WC \_\_\_\_\_

**Installation Checklist**

- |                              |                             |   |  |
|------------------------------|-----------------------------|---|--|
| <input type="checkbox"/> N/A | <input type="checkbox"/> OK | <input type="checkbox"/> Machine leveled  |  |
| <input type="checkbox"/>     |                             | <input type="checkbox"/> Voltage/Phase correct _____ V _____ Ph                   |  |
| <input type="checkbox"/>     |                             | <input type="checkbox"/> Circuit breaker(s) sized correctly _____ A               |  |
| <input type="checkbox"/>     |                             | <input type="checkbox"/> Water pressure meets min. requirements _____ PSI         |  |
| <input type="checkbox"/>     |                             | <input type="checkbox"/> Water supply temperature meets min. requirements _____ F |  |
| <input type="checkbox"/>     |                             | <input type="checkbox"/> Plumbing checked for leaks                               |  |
| <input type="checkbox"/>     |                             | <input type="checkbox"/> Fill/Drain lines plumbed correctly                       |  |
| <input type="checkbox"/>     |                             | <input type="checkbox"/> Spray Manifolds in place and secure                      | <input type="checkbox"/> N/A <input type="checkbox"/> OK |
| <input type="checkbox"/>     |                             | <input type="checkbox"/> Strainer Pans in place                                   | <input type="checkbox"/> Soap dispenser installed        |
| <input type="checkbox"/>     |                             | <input type="checkbox"/> Curtains in proper place                                 | <input type="checkbox"/> Rinse Injector installed        |
| <input type="checkbox"/>     |                             | <input type="checkbox"/> Dampers adjusted/working properly                        | <input type="checkbox"/> Parts manual included           |
| <input type="checkbox"/>     | <input type="checkbox"/>    | <input type="checkbox"/> Motor rotation is correct                                |  |
| <input type="checkbox"/>     | <input type="checkbox"/>    | <input type="checkbox"/> Conveyor Belt Tension adjusted properly                  |  |
| <input type="checkbox"/>     | <input type="checkbox"/>    | <input type="checkbox"/> Steam Condensate/Return line routed correctly            |  |

**Demonstration Checklist**

(To be completed by Stero Representative)

- |                              |                             |   |
|------------------------------|-----------------------------|---|
| <input type="checkbox"/> N/A | <input type="checkbox"/> OK | <input type="checkbox"/> Demonstrated RUN cycle                     |
| <input type="checkbox"/>     |                             | <input type="checkbox"/> Demonstrated Shutdown procedures           |
|                              |                             | <input type="checkbox"/> Warranty policy explained                  |
|                              |                             | <input type="checkbox"/> Cleaning procedures explained              |
|                              |                             | <input type="checkbox"/> Normal maintenance procedures demonstrated |

**Water Temperatures**

- |                              |                             |  |
|------------------------------|-----------------------------|--|
| <input type="checkbox"/> N/A | <input type="checkbox"/> OK | <input type="checkbox"/> Scrapper Temperature _____ F        |
|                              |                             | <input type="checkbox"/> Wash Temperature _____ F            |
|                              |                             | <input type="checkbox"/> Rinse Temperature _____ F           |
|                              |                             | <input type="checkbox"/> Auxiliary Rinse Temperature _____ F |
|                              |                             | <input type="checkbox"/> Final Rinse Temperature _____ F     |

**Booster Heater Information**  N/A \_\_\_\_\_ V \_\_\_\_\_ Ph

Manufacturer \_\_\_\_\_ Model \_\_\_\_\_

Serial No. \_\_\_\_\_ Type of Heat \_\_\_\_\_

The above machine has been inspected and demonstrated in the presence of the customer by a representative authorized by Stero.

\_\_\_\_\_  
Stero Representative Signature

\_\_\_\_\_  
Customer Signature

All new Stero Dishwashing Machines are warranted against defects in workmanship and materials for a period of one year from date of start-up by the original owner. Warranty card MUST be filled out and RETURNED to the manufacturer within 10 days from the date of delivery to the original owner. Warranty does not apply to any dishwasher which has been subject to accident, alteration, misuse or damages resulting from incorrect installation on the part of the contractor.

Any repair work performed on the above dishmachine by persons other than Authorized Stero Service Agencies is the sole responsibility of the customer.

\_\_\_\_\_ Customer

\_\_\_\_\_ Service Agent

Cut Here

