

SOMERSET

CDR-2100

Side Operated Dough Roller OPERATIONS MANUAL



WARNING!!! DO NOT CLEAN OR SERVICE THE MACHINE WITHOUT PRESSING THE RED BUTTON AND UNPLUGGING THE ELECTRICAL CORD FROM THE POWER SUPPLY. KEEP YOUR FINGERS AND HANDS FROM THE ROLLER AREA WHEN OPERATING OR SERVICING THE MACHINE. DO NOT OPERATE THE MACHINE WITHOUT THE GUARDS IN PLACE. IF THE MACHINE KEEPS RUNNING WITH SAFETY GUARDS REMOVED, IMMEDIATELY PRESS THE STOP BUTTON AND REMOVE THE PLUG FROM THE POWER SOURCE. CALL THE FACTORY OR A QUALIFIED SERVICE REPRESENTATIVE. DO NOT ATTEMPT TO OPERATE THE MACHINE UNTIL PERMITTED BY THE SERVICE TECHNICIAN.

SOMERSET INDUSTRIES

137 PHOENIX AVE • LOWELL, MA 01852 • USA • +1- 978-667-3355

Email: somerset@smrset.com

Web: www.smrset.com

NOTICE: READ ALL INSTRUCTIONS BEFORE YOU START!!

UNCRATING AND SETUP

Cut off the fastener wrapped around the machine and the base.

Lift the machine straight up out of the wooden base.

Install the machine in its final position or temporarily secure it to a solid surface. Wipe off any dirt that may have accumulated during shipping. Use a soft cloth.

Check the nameplate for correct voltage and frequency.

Plug the machine to the proper power source that matches the nameplate requirements.

Turn the power "ON" and check for proper operation of the machine.

!! WARNING !!

NEVER OPERATE THE MACHINE WITHOUT GUARDS IN PLACE!!

KEEP YOUR HANDS AWAY FROM THE CHUTE !!

DO NOT INSERT FOREIGN OBJECTS INTO THE CHUTE !!

DO NOT CLEAN MACHINE WHILE CONNECTED TO ELECTRICAL SUPPLY!!

WATCH YOUR HANDS AND FINGERS !!

MACHINE PREPARATION

The thickness of the final dough is determined by the gap between the rollers. Machines leaving the factory are adjusted as follows: The top dial is aligned with number 4. The bottom dial is aligned with number 2. If these numbers are not correct or your product requires other adjustments please make adjustments as follows:

Loosen the top clamping knob, move the handle such that the dial points to line 4, then tighten the clamping knob.

Loosen the bottom clamping knob, move the handle such that the dial points close to line 2, then tighten the clamping knob.

You may adjust both handles in any direction to produce the final product you require. For round pieces keep the 2:1 (top: bottom) ratio.

Please note that the dial numbers are for reference only.

Make sure the safety cover is on top and secured by four thumb screws.

DOUGH PREPARATION

For best results the dough to be rolled should be at room temperature.

The size and shape of the dough ball affects the size and shape of the finished crust. For round crusts, take a round piece of dough and flatten it slightly.

Dust the dough pieces with flour before putting them in the machine.

NOTE:
MACHINE WILL NOT OPERATE WHEN THE SAFETY COVER IS REMOVED.

Dust the chute and rear pan tray with flour before using the machine.

OPERATING PROCEDURE

First load the dough in to the top chute, it will come through the first pair of rollers oblong in shape, and from the second set of rollers round in shape.

The rollers are easily adjustable to any thickness of pizza dough or crust you may need.

Load the dough into the chute.



**** If dough does not slide easily on the discharge trays, dust the trays with flour. ****

If the dough tears or the machine makes a thumping sound, this indicates that the dough is too thick to go through that particular setting of the rollers, which means your roller adjustment has to be opened more, or the dough is too cold and stiff and requires a longer rest period before use.

Turn the elongated piece of dough ¼ of a turn, and at the same time push it back towards the second set of rollers.



The rounded piece of dough comes out on the discharge tray.



!! WARNING !!
IF THE DOUGH GETS STUCK IN THE CHUTE,
NEVER ATTEMPT TO MOVE THE DOUGH BY HAND WHILE THE
MACHINE IS RUNNING.

CLEANING

!! CAUTION !!

DISCONNECT THE POWER CORD OF THE MACHINE BEFORE CLEANING!!



Remove the safety cover by removing the four thumb screws.
All scrapers are readily removable.

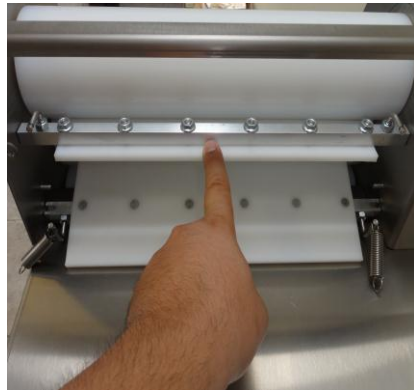

#3 & #4 attach to one another. The #4 scraper lays on top of the scraper pins and the beveled edge pushes towards the top roll. The springs from the #3 scraper attach to the #4 scraper forcing the slots in the shaft to go inside the scraper pins. The #3 beveled edge pushes against the middle roll and acts as a guard also



The #2 scraper lays on top of the bottom roll and is attached to the discharge tray as one piece. To remove the tray reach under the discharge tray and detach the scraper springs from the pins. Lift the tray up towards the machine and scraper will dislodge from the scraper pins.



The #1 scraper lays under the middle roll and attaches to the scraper pins on the inside walls of the machine. The beveled edge points in between the middle and bottom roll.

Clean the rolls with dry cloth (never use water).

Quick Tips

Clean the rolls with a dry cloth. (NEVER USE WATER)

Install the scrapers in the opposite order of their removal.

Close the safety cover and secure it with the 4 thumb screws.

Machine is ready to use.

If rolls ever start to squeal due to dryness, remove and clean the scraper blades thoroughly and rub the beveled edge with a cooking oil, like vegetable or canola. This technique will remove the squealing sound you get from friction between the roller and the dry scraper.

!! CAUTION !!

***THIS MACHINE IS MAINTENANCE FREE.
NEVER USE OIL OR GREASE ON ANY OF THE MECHANICAL PARTS OF THE MACHINE.
ALL MECHANICAL PARTS ARE PERMANENT SELF LUBRICATED.***



REV.	DESCRIPTION	DATE	APPROVED

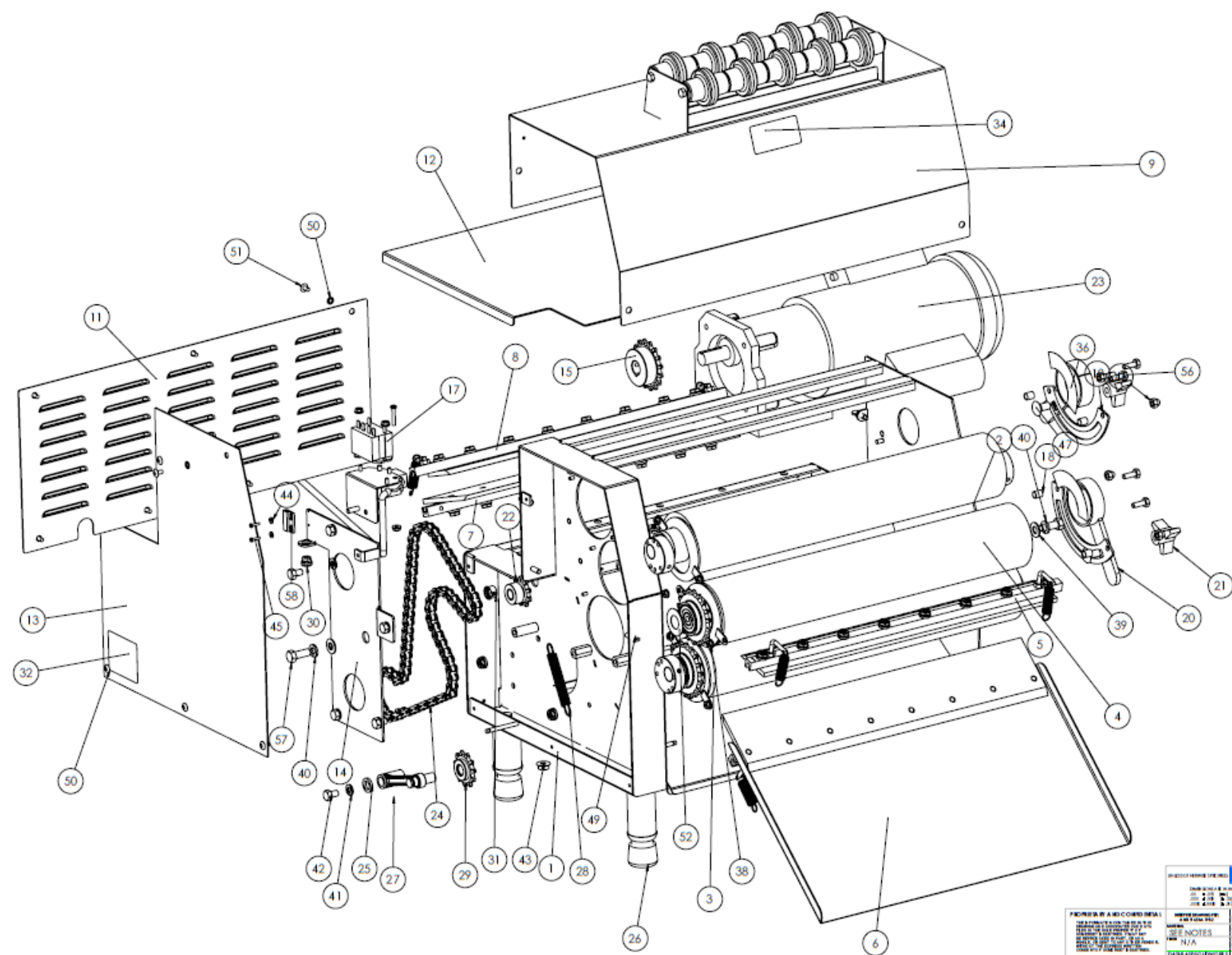

SOMERSET SOMERSET INDUSTRIES, INC. NORTH BILLERICA, MA 01862	
2100 EXPLODED	
PART NUMBER: 2100-0001 DATE: 01/15/00 DRAWN BY: J. J. BROWN CHECKED BY: J. J. BROWN DATE: 01/15/00 APPROVED BY: J. J. BROWN DATE: 01/15/00	REV. 1 DATE: 01/15/00 BY: J. J. BROWN
SEE DWG. NO. D 2100-PART C SCALE: 1:2 (2X) (1/2" = 1")	SHEET 1 OF 2

D 2100-PART C

ITEM NO.	PART NUMBER	DESCRIPTION	QTY.
1	2100-010	FRAME, CDR-2100 MAIN	1
	2100-011	BASE, RIGHT SIDE	1
	3010-219	PEM, FH-0616-16Z	4
	3010-201	PEM, YC3-16144	2
	3010-203	PEM, FHS-207-8	4
	3010-206	PEM, FHS 420-12	4
	2000-015	LOCATOR PLATE	2
	2000-015	LOCATOR PLATE	1
	2100-013	PARTITION	1
	2100-012	SIDE, LEFT	1
	3010-201	PEM, YC3-16144	2
	3010-203	PEM, FHS-207-8	4
	3010-204	PEM, FHS-0518-8	5
	3010-205	PEM, FHS-832-6	6
	2100-014	FILLER, LEFT SIDE	1
	3010-206	PEM, FHS 420-12	1
	0500-015	LOCATOR HSG #10	1
	2100-016	ANGLE, BACK	1
	2000-017	CHANNEL, TOP	2
	2000-415	LEG, ASM COMPLETE	4
	4000-200	INSERT, LEG ADJ	1
	2000-413	LEG, WELDMENT TUBE&PLUG	1
	3010-153	STUD, SCRAPER 2"	1
	3000-303	NUT, FLANGE 1/4-20	2
	4000-233	SPACER, HEX 0.5 X 1.0	4
	2000-431	SHAFT, ALIGNMENT, IDLER SUPPORT	2
	3000-102	WASHER, LOCK SPLIT 5/16	1
	3000-406	SCREW, 5/16-18 X 3/4 HEXHD GR8	1
2	2100-400	ROLL ASM UPPER	1
	2000-407	SHAFT, UPPER AND LOWER	1
	2000-457	ROLL SYNTHETIC/PIPE 20"	1
	2000-403	PIPE ROLL 21.110	1
	2000-451	ROLL ETF 00039TIVAR 20,125	1
	4000-100	BEARING, R12RS ROLL	2
	2000-412	SPROCKET 41B18H ROLL	1
	2100-318	DISC TOP COMPLETE 2100	1
	2100-320	DISC, TOP	1
	2000-023	BRACKET, DISK	2
	3010-302	PIN, 21S 187-125	3
	3000-225	WASHER, NYLATRON 1.50	2
	2000-411	ECCENTRIC, UNIVERSAL	2
3	2100-401	ROLL ASM LOWER	1
	2000-407	SHAFT, UPPER AND LOWER	1
	2000-457	ROLL SYNTHETIC/PIPE 20"	1
	2000-403	PIPE ROLL 21.110	1
	2000-451	ROLL ETF 00039TIVAR 20,125	1
	4000-100	BEARING, R12RS ROLL	2
	2000-412	SPROCKET 41B18H ROLL	1
	2100-317	DISC LOWER COMPLETE 2100	1
	2100-321	DISC, LOWER	1
	2000-023	BRACKET, DISK	2
	3010-302	PIN, 21S 187-125	3
	3000-225	WASHER, NYLATRON 1.50	2
	2000-411	ECCENTRIC, UNIVERSAL	2
4	2000-402	ROLL ASM MIDDLE UHMW 20"	1
	2000-408	SHAFT, MIDDLE 20	1
	2000-457	ROLL SYNTHETIC/PIPE 20"	1
	2000-403	PIPE ROLL 21.110	1
	2000-451	ROLL ETF 00039TIVAR 20,125	1
	4000-100	BEARING, R12RS ROLL	2
	2000-412	SPROCKET 41B18H ROLL	1
	2000-316	DISC MIDDLE COMPLETE	1
	2000-319	DISC, MIDDLE	1
	2000-023	BRACKET, DISK	2
	3010-302	PIN, 21S 187-125	1

ITEM NO.	PART NUMBER	DESCRIPTION	QTY.
5	2100-500	SCRAPER COMPLETE #1	1
	2100-520	SHAFT, SCRAPER #1 2100	1
	2100-510	SCRAPER #1	1
	3010-202	PEM, FHS-0420-16	8
	3000-303	NUT, FLANGE 1/4-20	8
	3010-155	STUD, SCRAPER 2 1/2" BENT	2
	4000-251	SPRING, SCRAPER	2
	3000-306	NUT, HEX 1/4-20	2
6	2100-501	SCRAPER, COMPLETE #2	1
	2000-523	SHAFT SCRAPER #4 2000	1
	2100-304	TRAY, DISCHARGE	1
	2100-511	SCRAPER #2 2100	1
	3010-202	PEM, FHS-0420-16	8
	3000-303	NUT, FLANGE 1/4-20	8
	3000-306	NUT, HEX 1/4-20	2
	3010-152	STUD, SCRAPER 2 1/2"	2
	4000-251	SPRING, SCRAPER	2
7	2100-502	SCRAPER, COMPLETE #3	1
	2100-522	SHAFT, SCRAPER #3	1
	2100-512	SCRAPER #3	1
	3010-202	PEM, FHS-0420-16	8
	3000-303	NUT, FLANGE 1/4-20	8
	3000-306	NUT, HEX 1/4-20	2
	3010-151	STUD, SCRAPER 1 3/8"	2
8	2100-503	SCRAPER, COMPLETE #4	1
	2000-521	SHAFT, SCRAPER #2 2000	1
	2100-513	SCRAPER #4 2100	1
	3010-202	PEM, FHS-0420-16	8
	3000-306	NUT, HEX 1/4-20	2
	3000-303	NUT, FLANGE 1/4-20	8
	3000-303	NUT, FLANGE 1/4-20	8
	3010-100	STUD, SCRAPER 21/32 BENT	2
	4000-251	SPRING, SCRAPER	2
9	2100-120	COVER, SAFETY COMPLETE 0115	1
	2100-121	COVER, SAFETY 2100	1
	2100-122	CHUTE, SAFETY COVER	1
	4000-150	MAGNET, SAFETY COVER	1
	0115-126	SHAFT, INTAKE ROLLER	2
	0115-125	INTAKE, ROLLER GUARD	20
	3000-410	SCREW, 1/4-20 X 1/2 HEXHD	4
10	2000-629	SWITCH PLATE ASSY	1
	2000-330	PLATE, P.B. SWITCH	1
	3010-205	PEM, FHS-832-6	2
	2000-330	PLATE, P.B. SWITCH	1
	5000-202	SWITCH POWER RED	1
	5000-203	SWITCH POWER GREEN	1
11	2100-301	PANEL, LOUVERED COMPLETE	1
12	2100-300	TRAY, INTAKE	1
	3010-101	STUD, WELD COPPER 1/4-20 X 1/2	8
	2100-300	TRAY, INTAKE	1
13	2100-302	COVER, HOUSING	1
14	2100-231	PLATE, ECCENTRIC COMPLETE	1
	2100-232	PLATE, ECCENTRIC	1
	2100-231	PLATE, ECCENTRIC COMPLETE	1
15	4000-502	SPROCKET 41B16H X 3/4 W/ KEY	1
16	5000-276	BUSHING, 90 STR REL HEYCO1320	1
17	2000-632	RELAY 110 VAC	1
	2000-328	BRACKET, RELAY	1
	3010-205	PEM, FHS-832-6	3
	3010-206	PEM, FHS 420-12	1
	2000-328	BRACKET, RELAY	1
	5000-230	HARNES, POWER MOLDED	1
	5000-150	RELAY, 120 VAC	1
	3000-416	SCREW, 8-32 X 1 PAN HD PH	1
	3000-300	NUT, FLANGE 8-32	3
18	2000-418	SPACER TUBING	4
19	2000-417	PLATE, ADJUST	2
20	2000-423	HANDLE, ROLL ADJUST	2

ITEM NO.	PART NUMBER	DESCRIPTION	QTY.
21	4000-400	KNOB, LOCKING	2
22	4000-522	SPROCKET 41B09 W/ GARLOCK BUSHING	1
	4000-500	SPROCKET 41B09H TAKEUP	1
	4000-551	BUSHING 08DU14 GARLOCK	1
23	5000-130	MOTOR/BASE ASSY BALDOR 3/4HP	1
	5000-108	GEARMOTOR, BALDOR 3/4HP	1
	3000-414	SCREW, 5/16-18 X 1 HEXHD	4
	3000-305	NUT, FLANGE 5/16-18	4
	2000-019	BASE, MOTOR W/ STUDS	1
	2000-018	BASE, MOTOR	1
	3010-215	PEM, FH 518-8 ZI	9
24	4000-362	CHAIN 41 RIV 77 INCL 1 C/L (2100)	1
25	4000-011	SPACER, .50ID X .78OD X .123 PL	1
26	4000-300	LEG TIP RUBBER	4
27	2100-428	ARM, IDLER	1
28	4000-252	SPRING, EXTENSION, 4LG X .5 DIA. X .063	1
29	2000-630	SPROCKET 41B11H IDLER W/BUSHING	1
	2000-430	SPROCKET 41B11H IDLER	1
	4000-550	BUSHING, GARLOCK	1
30	5000-274	BUSHING, STR REL MICRO	1
31	5000-278	BUSHING, FINGER .625 HOLE	1
32	5000-311	LABEL, ETL	1
33	5000-312	LABEL, "SOMERSET 3"	1
34	5000-313	LABEL, "KEEP FINGERS..."	2
35	5000-314	LABEL, "DO NOT OPERATE..."	1
36	5000-316	LABEL, CCW INDICATOR GRADUATED	2
37	5000-317	LABEL, NSF	1
38	8000-300	NUT, FLANGE 8-32	8
39	8000-201	WASHER, FLAT 3/8	2
40	8000-103	WASHER, LOCK SPLIT 3/8	2
41	8000-102	WASHER, LOCK SPLIT 5/16	6
42	8000-405	SCREW, 5/16-18 X 1/2 HEXHD	6
43	8000-305	NUT, FLANGE 5/16-18	9
44	8000-204	WASHER, FLAT #4	2
45	8000-400	SCREW, 4-40 X 1/2 PAN HD PH	2
46	8000-302	NUT, ACORN 1/4-20	4
47	8000-408	SCREW, 3/8-16 X 3/4 CARRIAGE BOLT	2
48	8000-303	NUT, FLANGE 1/4-20	9
49	8000-403	SCREW, 1/4-20 X 1/2 THUMB W/SHOULDER	4
50	8000-101	WASHER LOCK #10 INT TOOTH	13
51	8000-402	SCREW, 10-32 X 3/8 TRUSS PH SS	13
52	8000-225	WASHER, NYLATRON 1.50	3
53	2000-424	STOP, HANDLE ADJ POSITION	4
54	8000-340	SCREW, 10-32 X 1/4 SET HEX	4
55	4000-420	WRENCH ALLEN 3/32	1
56	8000-404	SCREW, 1/4-20 X 3/4 HEXHD	4
57	8000-409	SCREW, 3/8-16X1 HEXHD SS	2
58	5000-225	SWITCH, ELECTRONIC	1
59	5000-261	WIRE NUT	5
60	5000-272	CABLE TIE, 3M	5

GOMERSET		SOMERSET INDUSTRIES, INC.	
NORTH BELLERUCA, MA 01853		NORTH BELLERUCA, MA 01853	
DATE: 11/11/03	TIME: 10:00 AM	SCALE: 1:1	REV: 1
BY: [Signature]	CHECKED: [Signature]	DATE: 11/11/03	REV: 1
APP: [Signature]	DATE: 11/11/03	SCALE: 1:1	REV: 1
DATE: 11/11/03	TIME: 10:00 AM	SCALE: 1:1	REV: 1
DATE: 11/11/03	TIME: 10:00 AM	SCALE: 1:1	REV: 1
DATE: 11/11/03	TIME: 10:00 AM	SCALE: 1:1	REV: 1
DATE: 11/11/03	TIME: 10:00 AM	SCALE: 1:1	REV: 1
DATE: 11/11/03	TIME: 10:00 AM	SCALE: 1:1	REV: 1
DATE: 11/11/03	TIME: 10:00 AM	SCALE: 1:1	REV: 1

© 2003 SOMERSET INDUSTRIES, INC.