



## CDR-600

# Side Operated Dough & Fondant Sheeters

## OPERATIONS MANUAL

**WARNING!!! DO NOT CLEAN OR SERVICE THE MACHINE WITHOUT PRESSING THE RED BUTTON AND UNPLUGGING THE ELECTRICAL CORD FROM THE POWER SUPPLY. KEEP YOUR FINGERS AND HANDS FROM THE ROLLER AREA WHEN OPERATING OR SERVICING THE MACHINE. DO NOT OPERATE THE MACHINE WITHOUT THE GUARDS IN PLACE. IF THE MACHINE KEEPS RUNNING WITH SAFETY GUARDS REMOVED, IMMEDIETLY PRESS THE STOP BUTTON AND REMOVE THE PLUG FROM THE POWER SOURCE. CALL THE FACTORY OR A QUALIFIED SERVICE REPRESENTATIVE. DO NOT ATTEMPT TO OPERATE THE MACHINE UNTIL PERMITTED BY THE SERVICE TECHNICIAN.**

### SOMERSET INDUSTRIES

137 PHOENIX AVE • LOWELL, MA 01852 • USA • +1- 978-667-3355

Email: [somerset@smrset.com](mailto:somerset@smrset.com)

Web: [www.smrset.com](http://www.smrset.com)

NOTICE: !! READ CAREFULLY ALL INSTRUCTIONS BEFORE YOU START!!

### UNCRATING AND SETUP

- Cut off the fastener wrapped around the machine and the base.
- Lift the machine straight up out of the wooden base.
- Install the machine in its final position or temporarily secure it to a solid surface.
- Wipe off any dirt that may accumulate during shipping. Use a soft cloth.
- Check the nameplate for correct voltage and frequency.
- Plug the machine to the proper power source that matches the nameplate requirements.
- Turn the power switch “ON”(green button) and the check for proper operation of the machine.

### WARNING!!

- NEVER OPERATE THE MACHINE WITHOUT GUARDS IN PLACE
- KEEP YOUR HANDS FROM INFEED
- DO NOT INSERT FOREIGN OBJECTS INTO INFEED
- DO NOT CLEAN MACHINE WHILE CONNECTED TO ELECTRICAL SUPPLY
- WATCH YOUR HANDS AND FINGERS

NOTE: The machine will not operate when safety cover is removed.

### OPERATING PROCEDURE

The rollers are easily adjustable to any thickness of crust you may need.  
Release the adjusting handle by squeezing the handle.

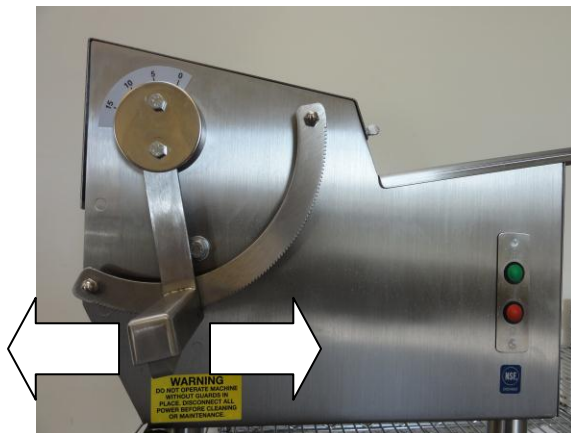
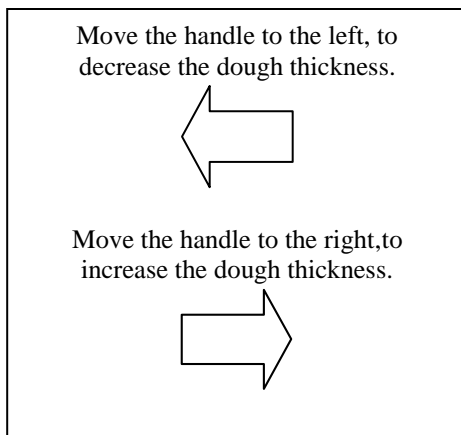

## OPERATION

Dust the infeed tray with the flour before using the machine.  
For best results the dough to be rolled should be at room temperature.  
Dust the dough with flour when putting it on the infeed tray.  
Follow steps 1 to 3 as in the following diagram:

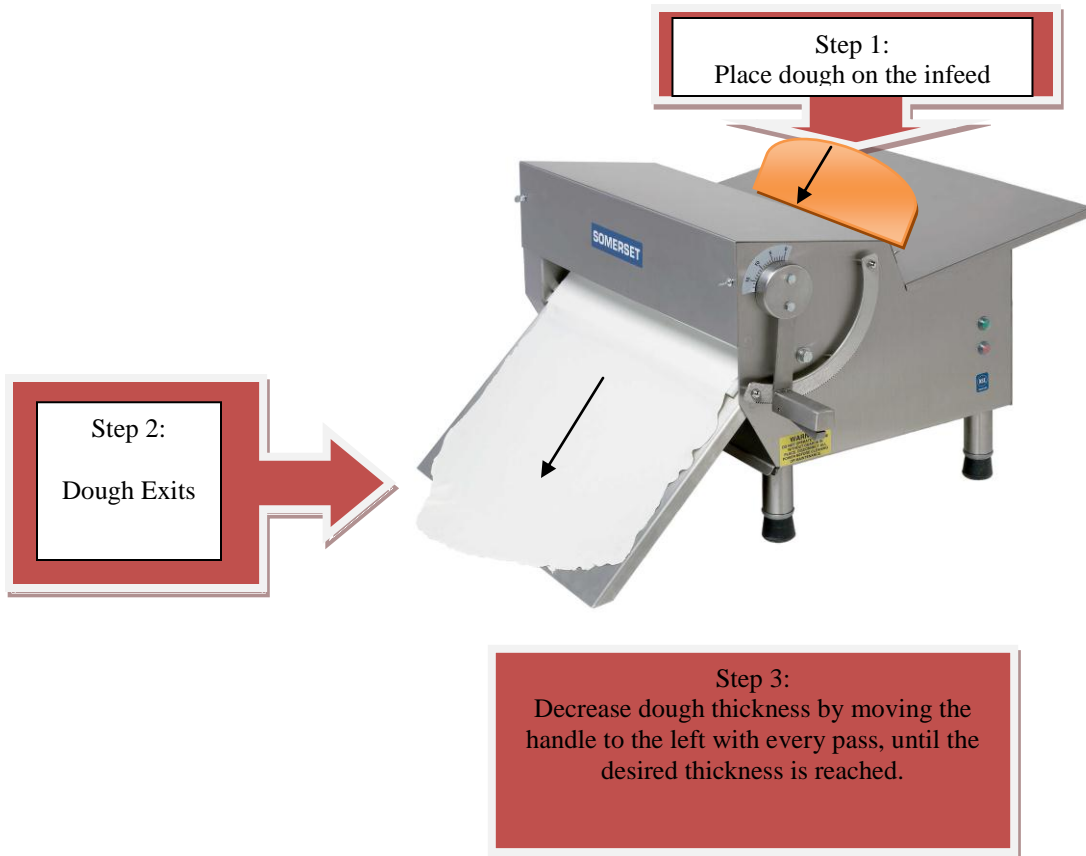

If the dough tears or the machine makes a thumping sound, this indicates that the dough is too thick to go through that particular setting of the rollers or the dough is too cold and stiff and requires longer rest period before use.

- IF THE DOUGH GETS STUCK, TURN THE POWER OFF, REMOVE SAFETY COVER THEN REMOVE THE DOUGH.
- NEVER ATTEMPT TO REMOVE THE DOUGH BY HAND WHILE THE MACHINE IS RUNNING.

## CLEANING

Before cleaning

Turn power off and disconnect the power cord of the machine

Remove the safety cover by removing the four thumbscrews.

**All scrapers are readily removable.**



### **Top scraper #3**

Remove scraper from its mounting pins by pushing scraper downward.

Unhook both springs by lifting scraper up and remove it.



### **Bottom scraper #2:**

Unhook both springs attached on scraper and remove it by lifting up.



By removing both scrapers, the whole machine is exposed and ready to be cleaned.

Clean the rolls with dry cloth (never use water).

Wipe rollers with lightly oiled cloth (use vegetable oil).

Wash, dry and apply a thin film of vegetable oil on the edge of scraper that touches the roller.

Install the scrapers in the opposite order of their removal.

Close the safety cover and secure it with the 4 thumbscrews.

Turn the power ON, and the machine is ready for use.

**!! CAUTION !!**

**!! THIS MACHINE IS MAINTENANCE FREE. !!**

**!! NEVER USE OIL OR GREASE ON ANY OF THE PARTS OF THE MACHINE. !!**

**!! ALL PARTS ARE PERMANENT SELF-LUBRICATED. !!**

### **Quick Tips**

- **Fondant Discharge Tray is only included with the CDR-500F or CDR-600F**
- **The Scraper pin under the scraper #2 is there for the discharge tray.**

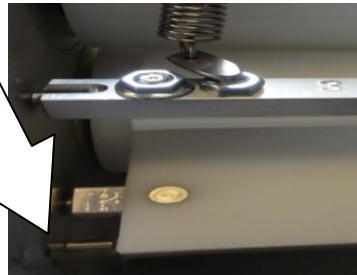

# CDR-600 EXPLODED DIAGRAM

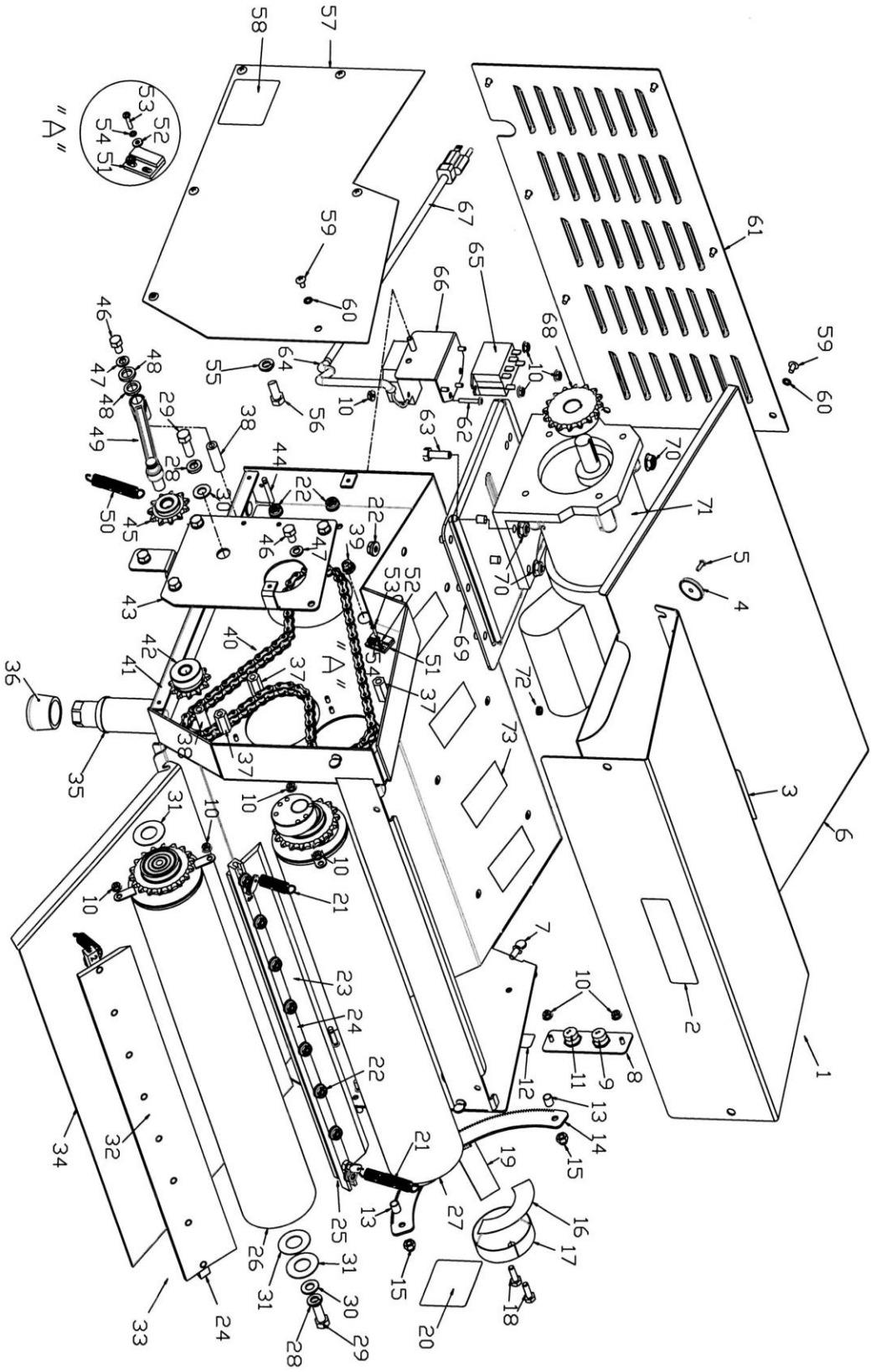

ITEM #	PART NUMBER	DESCRIPTION	QTY.	ITEM #	PART NUMBER	DESCRIPTION	QTY.
1	0600-121	COVER,SAFETY COMPLETE	1	39	5000-278	BUSHING	1
2	5000-312	LABEL, "SOMERSET"	1	40	4000-353	CHAIN 41 RIV 74	1
3	5000-313	LABEL, "KEEP FINGERS..."	1	41	0600-010	FRAME	1
4	4000-150	MAGNET	1	42	4000-521	SPROCKET, TAKE UP	1
5	3010-500	RIVET	1	43	0500-231	PLATE ECCENTRIC COMPLETE	1
6	0600-300	TRAY,INTAKE	1	44	3010-151	FLANGE, STUD	1
7	3000-403	SCREW, THUMB	4	45	2000-630	SPROCKET, IDLER	1
8	2000-330	PLATE, P.B. SWITCH	1	46	3000-405	SCREW, HEXHD	6
9	5000-203	SWITCH POWER GREEN	1	47	3000-102	WASHER, LOCK SPLIT	6
10	3000-300	NUT, FLANGE	10	48	4000-011	SPACER	2
11	5000-202	SWITCH POWER, RED	1	49	2000-428	ARM, IDLER	1
12	5000-317	LABEL, NSF	1	50	4000-252	SPRING, EXTENSION	1
13	2000-418	SPACER TUBING	3	51	5000-225	SENSOR	1
14	0500-417	PLATE, ADJUST	1	52	3000-204	WASHER, FLAT	2
15	3000-302	NUT, ACORN	2	53	3000-400	SCREW	2
16	5000-316	LABEL, INDICATOR	1	54	3000-104	WASHER, LOCK SPLIT	2
17	0500-623	COVER, ECCENTRIC	1	55	3000-102	WASHER, LOCK SPLIT	1
18	3000-404	SCREW, HEXHD	2	56	3000-406	SCREW, HEXHD	1
19	0500-424	HANDLE, ADJUST COMPLETE	1	57	0500-302	COVER,HOUSING	1
20	5000-314	LABEL, "DO NOT OPERATE..."	1	58	5000-311	LABEL, ELECTRICAL	1
21	4000-251	SPRING, SCRAPER	4	59	3000-402	SCREW	14
22	3000-303	NUT, FLANGE	16	60	3000-101	WASHER LOCK	14
23	0600-512	SCRAPER #3	1	61	0600-301	PANEL, LOUVERED COMPLETE	1
24	0600-520	SHAFT, SCRAPER	2	62	3000-416	SCREW	1
25	0600-502	SCRAPER COMPLETE #3	1	63	3000-414	SCREW, HEXHD	4
26	0600-402	ROLL,ASM MIDDLE	1	64	5000-276	BUSHING	1
27	0600-400	ROLL ASM UPPER	1	65	5000-150	RELAY, 120 VAC	1
28	3000-103	WASHER, LOCK SPLIT	2	65	5000-151	RELAY, 220 VAC	1
29	3000-409	SCREW, HEXHD SS	2	66	2000-328	BRACKET, RELAY	1
30	3000-201	WASHER, FLAT	2	67	5000-230	HARNES, POWER	1
31	3000-225	WASHER	3	68	4000-502	SPROCKET W/ KEY	1
32	0600-511	SCRAPER #2	1	69	2000-019	BASE, MOTOR W/ STUDS	1
33	0600-501	SCRAPER COMPLETE #2	1	70	3000-305	NUT	13
34	0600-304	TRAY, DISCHARGE	1	71	5010-180	BASIC, GEARMOTOR W/BASE 115 VAC	1
35	2000-415	LEG, ASM COMPLETE	4	71	5010-182	FAST, GEARMOTOR W/BASE 115 VAC	1
36	4000-300	LEG TIP RUBBER	4	71	5010-280	BASIC, GEARMOTOR W/BASE 220 VAC	1
37	4000-233	SPACER	4	71	5010-282	FAST, GEARMOTOR W/BASE 220 VAC	1
38	2000-431	SHAFT, IDLER	2	72	4000-303	BUMPER	1
				73	4000-306	ISOLATION, RUBBER STRIP	4

CDR-600