



southbend

A MIDDLEBY COMPANY

**IMPORTANT
FOR FUTURE REFERENCE**

**Please complete this
information and retain this
manual for the life of the
equipment.**

MODEL # _____

SERIAL # _____

DATE PURCHASED _____

OWNER'S MANUAL

INSTALLATION
USER'S GUIDE
SERVICE
PARTS

COUNTER TOP CONVECTION STEAMER

**MODELS: 2001 / DUAL POWER
SINGLE POWER SOURCE UNITS**

These instructions should be read thoroughly before attempting installation. Installation and Start Up should be performed by a qualified service technician. The Manufacturer, Southbend (Head Office: 1100 Old Honeycutt Rd., Fuquay-Varina, North Carolina 27526), informs you that unless the installation instructions for the above described Southbend product are followed and performed by a qualified service technician, (a person experienced in and knowledgeable concerning the installation of commercial gas and/or electrical cooking equipment) then the terms and conditions of the Manufacturer's Limited Warranty will be rendered void and no warranty of any kind shall apply.

If the equipment has been changed, altered, modified or repaired by other than a qualified service technician during or after the 12-month limited warranty period, then the manufacturer shall not be liable for any incidental or consequential damages to any person or to any property which may result from the use of the equipment thereafter. Some States do not allow the exclusion or limitation of incidental or consequential damages, so the above limitation or exclusion thereto may not apply to you.

In the event you have any questions concerning the installation, use, care, or service of the product, write Customer Service Department, Southbend, 1100 Old Honeycutt Rd., Fuquay-Varina, North Carolina 27526.

WARNING: Improper installation, adjustment, alteration, service or maintenance can cause property damage, injury or death. Read the installation, operating and maintenance instructions thoroughly before installing or servicing this equipment.

**COUNTER TOP
CONVECTION STEAMER
(Manual Section CS)**

Congratulations! You have just purchased one of the finest pieces of heavy-duty, commercial cooking equipment on the market today.

You will find that your new equipment, like all Southbend equipment, has been designed and manufactured to some of the toughest standards in the industry — those of Southbend. Each piece of Southbend equipment has been carefully engineered and designs have been verified through laboratory tests and field installations in some of the more strenuous commercial cooking applications. With proper care and field maintenance, you will experience years of reliable, trouble-free operation from your Southbend equipment. To get the best results, it's important that you read this manual carefully.

TABLE OF CONTENTS:

SECTION ONE- INSTALLATION	
Specifications	1
Installation	2
Performance Check.....	5
SECTION TWO - USER'S GUIDE	
Warranty.....	1
Operation.....	2
Cooking Hints.....	3
Maintenance.....	7
SECTION THREE - SERVICE	
Adjustments	1
Troubleshooting	5
Schematic Drawings.....	7
SECTION FOUR - PARTS	
Parts List.....	1

RETAIN THIS MANUAL FOR FUTURE REFERENCE.

INTENDED FOR COMMERCIAL USE ONLY. NOT FOR HOUSEHOLD USE.

WARNING – WARRANTY WILL BE VOID IF
A. SERVICE WORK IS PERFORMED BY OTHER THAN A QUALIFIED TECHNICIAN
B. OTHER THAN GENUINE SOUTHBEND REPLACEMENT PARTS ARE INSTALLED.

FOR YOUR SAFETY
DO NOT STORE OR USE GASOLINE OR OTHER FLAMMABLE VAPORS
AND LIQUIDS IN THE VICINITY OF THIS OR ANY OTHER APPLIANCE.
KEEP AREA AROUND APPLIANCES FREE AND CLEAR FROM COMBUSTIBLES.
IN THE EVENT A GAS ODOR IS DETECTED. SHUT DOWN EQUIPMENT AT THE MAIN
SHUTOFF VALVE AND CONTACT THE LOCAL GAS COMPANY OR GAS SUPPLIER FOR
SERVICE.



southbend

A MIDDLEBY COMPANY

1100 Old Honeycutt Road
Fuquay, NC 27526
(919) 552-9161
FAX (919) 552-9798
(800) 348-2558

COUNTER TOP CONVECTION STEAMER USER'S GUIDE

LIMITED WARRANTY

Southbend warrants that the equipment, as supplied by the factory to the original purchasers, is free from defects in materials and workmanship. Should any part thereof become defective as a result of normal use within the period and limits defined below, then at the option of Southbend such parts will be repaired or replaced by Southbend or its Authorized Service Agency. This warranty is subject to the following conditions:

If upon inspection by Southbend or its Authorized Service Agency it is determined that this equipment has not been used in an appropriate manner, has been modified, has not been properly maintained, or has been subject to misuse or misapplication, neglect, abuse, accident, damage during transit or delivery, fire, "flood, riot or Act of God, then this warranty shall be void. Specifically excluded under this warranty are claims relating to installation; examples are improper utility connections and improper utilities supply. Claims relating to normal care and maintenance are also excluded; examples are calibration of controls, and adjustments to pilots and burners.

Equipment failure caused by inadequate water quality is not covered under warranty. WATER QUALITY must not exceed the following limits: Total Dissolved Solids (TDS) - 60 PPM (Parts Per Million). Hardness - 2 Grains or 35 PPM, PH Factor - 7.0 to 7.5. Water pressure 30 PSI minimum, 60 PSI maximum. Boiler maintenance is the responsibility of the owner and is not covered by warranty.

This equipment is intended for commercial use only. Warranty is void if equipment is installed in other than commercial application.

Repairs under this warranty are to be performed only by a Southbend Authorized Service Agency. Southbend can not be responsible for charges incurred from other than Authorized Southbend Agencies. THIS WARRANTY MUST BE SHOWN TO AN AUTHORIZED SERVICE AGENCY WHEN REQUESTING IN-WARRANTY SERVICE WORK. THE AUTHORIZED SERVICE AGENCY MAY AT HIS OPTION REQUIRE PROOF OF PURCHASE. This warranty does not cover services performed at overtime or premium labor rates nor does Southbend assume any liability for extended delays in replacing or repairing any items in the equipment beyond the control of Southbend. "Southbend shall not be liable for consequential or special damages of any nature that may arise in connection with such product or part." Should service be required at times which normally involve overtime or premium labor rates, the owner shall be charged for the difference between normal service rates and such premium rates. In all circumstances, a maximum of one hundred miles in travel and two and one half hours (25) travel time shall be allowable. In all cases the closest Southbend Authorized Agency must be used. The actual warranty time periods and exceptions are as follows:

This warranty only covers product shipped into the 48 contiguous United States and Hawaii, one year labor, one year parts effective from the date of original purchase. There will be no labor coverage for equipment located on any island not connected by roadway to the mainland. Exceptions to standard warranty, effective within above limitations:

Glass Windows, Door Gaskets, Rubber Seals, Light Bulbs, Ceramic Bricks,

Sight Glasses, Cathodic Descalers or Anodes 90 days material and labor

Stainless Steel Fry Pot..... .4 years extended material warranty on fry pot only — no labor

Stainless Steel Open Top Burners.....4 years extended material warranty on burners only — no labor

Pressure Steam Boiler Shell Prorated 4 years extended warranty on boiler shell only — no labor

Boiler shells which have not been properly maintained will not be covered by warranty.

In all cases parts covered by a five year warranty will be shipped FOB the factory after the first year. Our warranty on all replacement parts which are replaced in the field by our Authorized Service Agencies will be limited to three months on labor, six months on materials (parts) effective from the date of installation. See LIMITED WARRANTY

- REPLACEMENT PARTS for conditions and limitations.

If the equipment has been changed, altered, modified or repaired by other than a qualified service technician during or after the one year limited warranty period, then the manufacturer shall not be liable for any damages to any person or to any property which may result from the use of the equipment thereafter.

"THE FOREGOING WARRANTY IS IN LIEU OF ANY AND ALL OTHER WARRANTIES EXPRESSED OR IMPLIED INCLUDING ANY IMPLIED WARRANTY OF MERCHANTABILITY OR FITNESS, AND CONSTITUTES THE ENTIRE LIABILITY OF SOUTHBEND. IN NO EVENT DOES THE LIMITED WARRANTY EXTEND BEYOND THE DURATION OF ONE YEAR FROM THE EFFECTIVE DATE OF SAID WARRANTY."



OPERATION

THEORY OF OPERATION:

Compared to other steam cookers with complicated boilers, the Southbend 2001 is a very simple machine. The bottom, or floor, of the compartment is heated. Water flows onto this heated surface, boils, and turns to steam. A fan circulates the steam in the compartment when the door is closed. There is no pressure.

All equipment must be installed correctly to insure proper operation and reliable service. Installation instructions must be followed by a qualified technician.

Before you turn the unit on, be sure that you have: POWER to unit, WATER to unit, and OPEN DRAIN. **NOTE:**

Your Southbend Convection Steamer must be thoroughly cleaned every day.

CAUTION: DO NOT USE VINEGAR OR ANY CORROSIVE CLEANER. USE ONLY CLEANERS APPROVED FOR STAINLESS STEEL.

Before starting the unit, review the following:

- A. Be sure overflow pipe in back right hand corner of the cooking compartment is in position.
- B. Be sure the drain outlet is not blocked in any way. (The Southbend 2001 drain line must be free venting.)
- C. Be sure the pan supports and fan guard are well secured.
- D. Be sure the drip pan is in proper position with the drain hole located above the drain outlet.

CONTROL INSTRUCTIONS:

1. For manual operation, press right-hand rocker switch to "MANUAL" and select your choice on left-hand rocker switch, "HI or LO." *Red and amber lights on switch turn on when it's "HI" power and amber light only when it's "LO" power.* Unit is now in operation and will be generating steam in a few minutes (approximately 4 minutes from a cold start).
2. For automatic timed operation, press right-hand rocker switch to "AUTOMATIC" and select your choice on left-hand rocker switch "HI" or "LO." Set timer by positioning knob pointer to desired time. When time elapses, buzzer will sound. Buzzer may be shut off by moving selector switch to "MANUAL," shutting unit off, resetting to a new time, or turning knob counter clock-wise past "0" time to Hold/Off position.
3. To restart timer, set to new time marking.

NOTE: For short time settings (under 20 minutes) first turn knob past "30" setting then back to desired time.

INSTRUCTIONS FOR TURNING OFF BUZZER:

The Southbend Steamer is supplied with a continuous ring buzzer. This buzzer is activated automatically in the automatic mode of operation when the cooking cycle is complete. This buzzer can be turned off by:



1. Resetting to a new time.
2. Shut unit off (left hand switch to middle position).
3. Set the right-hand rocker switch to manual.
4. Turn knob full counterclockwise past "0" time to Hold/Off position.



Southbend equipment is sturdily constructed of the best quality materials and is designed to provide durable service when treated with ordinary care. To expect the best performance, your equipment must be maintained in good condition and cleaned daily. Naturally, the periods for this care and cleaning depend on the amount and degree of usage.

DAILY CLEANING:

Following daily and periodic maintenance procedures will enhance long-life for your equipment. Climatic conditions — salt air — may require more thorough and frequent cleaning or the life of the equipment could be adversely affected.

As with any cooking utensil, the unit should be thoroughly washed with a mild detergent and warm water every day.

Remove the pan supports, drip pan, fan guard, and overflow pipe. Wash separately.

All water will drain out of the compartment. Clean all interior surfaces, including the fan and heating element with a food equipment cleansing and de-liming solution. Rinse with clean water.

Return all cleaned parts to the unit to make ready for the next day's operation.

It is advisable to leave door open when the unit is not in use. This allows the unit to dry thoroughly after cleaning and also prolongs the life of the door seal.

CAUTION: DO NOT USE ANY CORROSIVE CLEANER. USE ONLY CLEANERS APPROVED FOR STAINLESS STEEL.

STAINLESS STEEL: To remove normal dirt, grease or product residue from stainless steel, use ordinary soap and water (with or without detergent) applied with a sponge or cloth. Dry thoroughly with a clean cloth. Never use vinegar or any corrosive cleaner.

To remove grease and food splatter or condensed vapors that have baked on the equipment, apply cleanser to a damp cloth or sponge and rub cleanser on the metal in the direction of the polishing lines on the metal. Rubbing cleanser as gently as possible in the direction of the polished lines will not mar the finish of the stainless steel. NEVER RUB WITH A CIRCULAR MOTION. Soil and burnt deposits which do not respond to the above procedure can usually be removed by rubbing the surface with SCOTCH-BRITE scouring pads or STAINLESS scouring pads. DO NOT USE ORDINARY STEEL WOOL as any particles left on the surface will rust and further spoil the appearance of the finish. NEVER USE A WIRE BRUSH, STEEL SCOURING PADS (EXCEPT STAINLESS), SCRAPER, FILE OR OTHER STEEL TOOLS. Surfaces which are marred collect dirt more rapidly and become more difficult to clean. Marring also increases the possibility of corrosive attack. Refinishing may then be required.

TO REMOVE HEAT TINT: Darkened areas sometimes appear on stainless steel surfaces where the area has been subjected to excessive heat. These darkened areas are caused by a thickening of the protective surface of the stainless steel and are not harmful. Heat tint can normally be removed by the foregoing, but tint which does not respond to this procedure calls for a vigorous scouring in the direction of the polish lines using SCOTCH-BRITE scouring pads or a STAINLESS scouring pad in combination with a powdered cleanser. Heat tint action may be lessened by not applying or by reducing heat to equipment during slack periods.

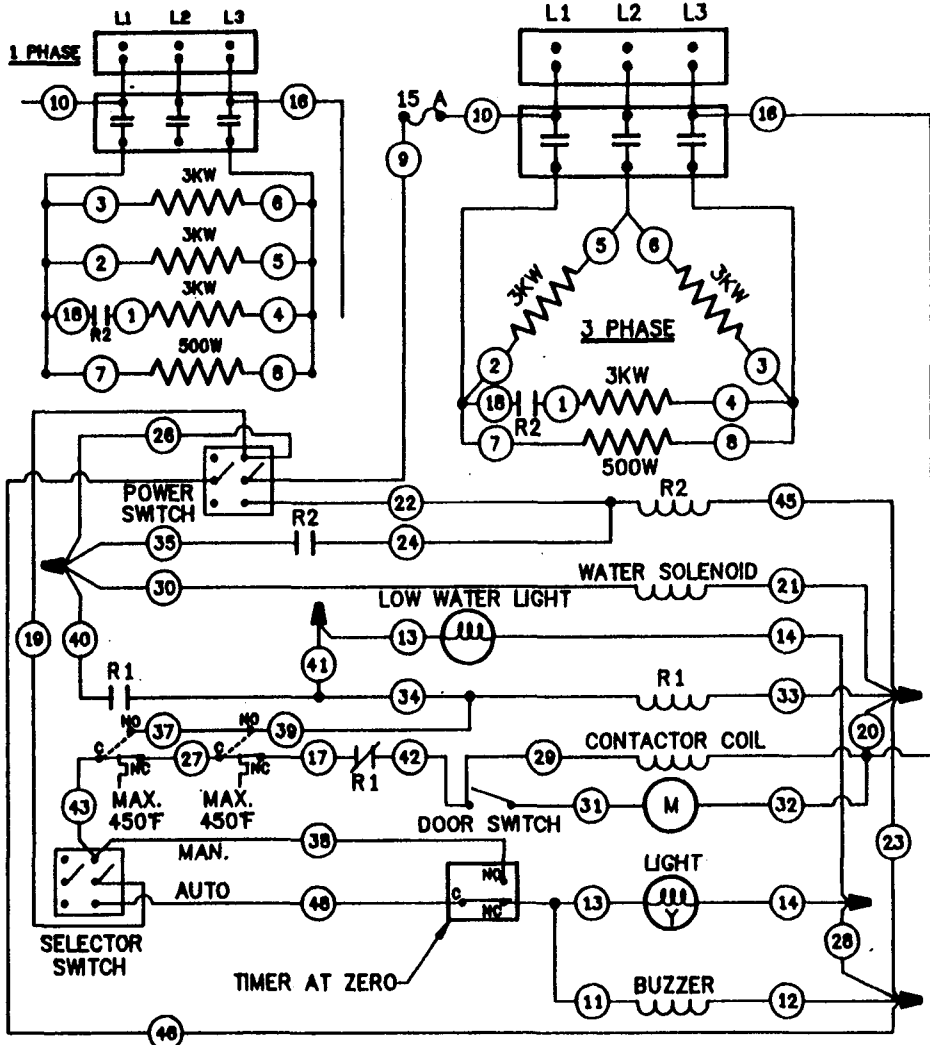

SCHEMATIC DIAGRAM

SOUTHBEND
WIRING DIAGRAM

U.S. WIRING DIAGRAM FOR SOUTHBEND MODEL 2001/DUAL POWER—without Element Thermostats
9.6 KW / 6.5 KW 60 HZ

P/N 1173246

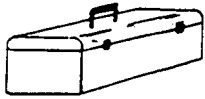

SERVICE

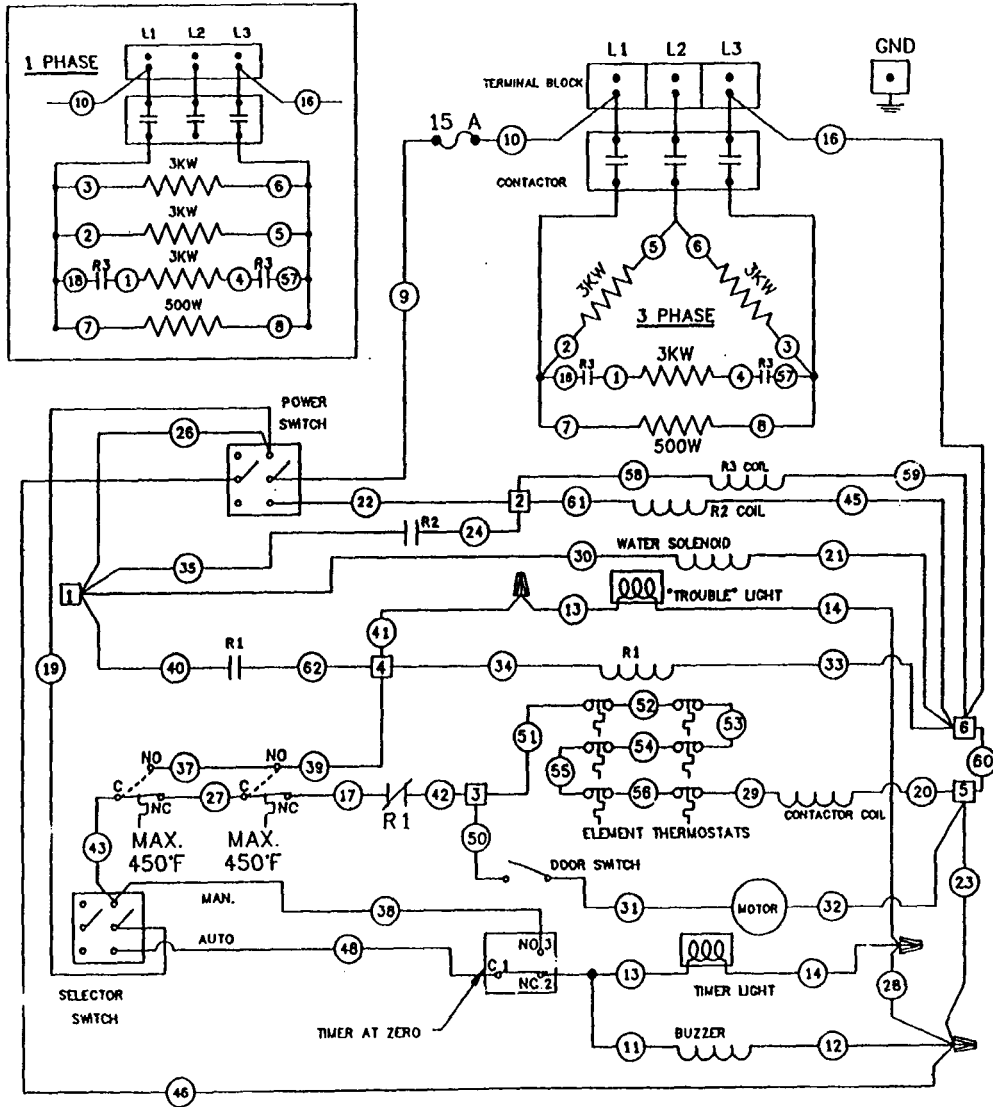

SOUTHBEND
WIRING DIAGRAM

U.S. WIRING DIAGRAM FOR SOUTHBEND MODEL 2001/DUAL POWER—with Element Thermostats
9.6 KW / 6.5 KW 60 HZ

P/N 1173452



southbend

A MIDDLEBY COMPANY

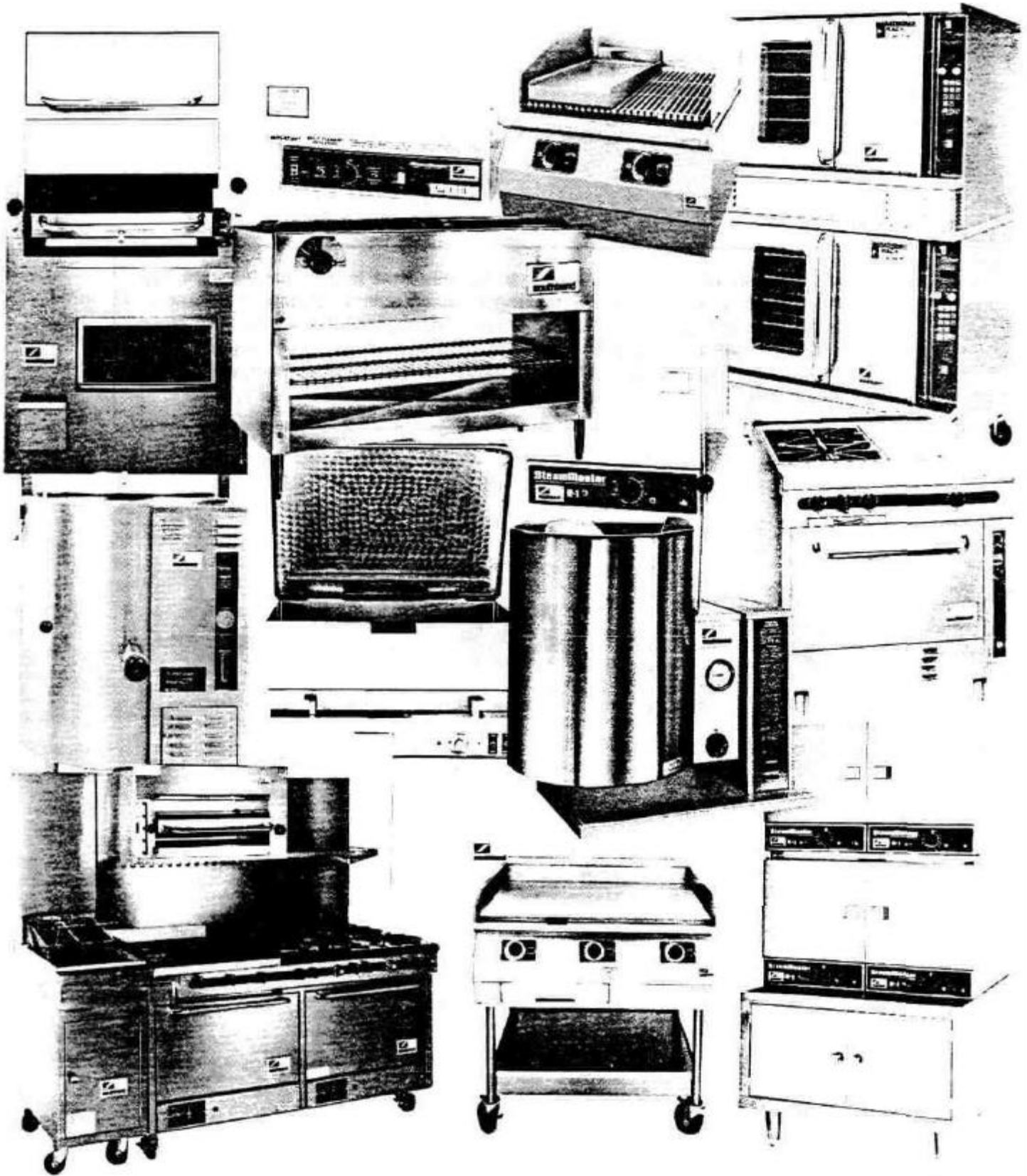

Convection Ovens
 Cook & Hold Convection Ovens
 Bake & Roast Ovens
 Pizza Ovens

Ranges
 Fryers
 Special & Custom Equipment
 Convection Steamers

Steam Kettles
 Tilting Braising Pans
 Cooker/Mixer Kettles
 Floor Model Broilers

Under Fired Broilers
 Salamander Broilers
 Cheese Melters
 Counter Top Broilers & Griddles

COUNTER TOP CONVECTION STEAMER

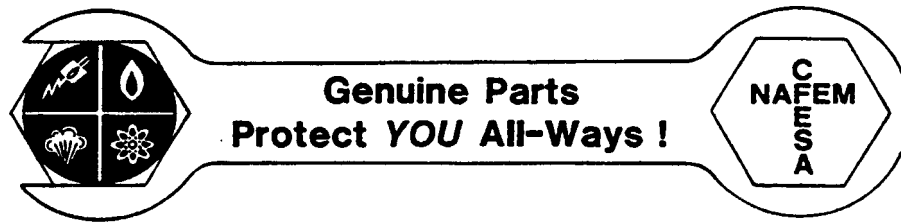

A product with the Southbend name incorporates the best in durability and low maintenance. We all recognize however, that replacement parts and occasional professional service may be necessary to extend the useful life of this unit. When service is needed, contact a Southbend Authorized Service Agency, or your dealer. To avoid confusion, always refer to the model number, serial number, and type of your unit.



A MIDDLEBY COMPANY

PART NUMBER 1173012

1100 Old Honeycutt Road
Fuquay-Varina, NC 27526
(919) 552-9161
FAX (919) 552-9798
(800) 348-2558

southbend SERVICE BULLETIN

TO: Southbend Parts & Service Distributors
FROM: Thomas S. Enyeart
Manager, Technical Services
DATE: February 11, 1991 **BULLETIN #9105**
SUBJECT: Model 2001 and R-1 In Line Water Strainer

Please insert this bulletin in your roaster Southbend manual in Section ST behind the 2001 manual.

A new improved in line water strainer is now being supplied on all Model 2001 and R-1 Convection Steamers. This is a Y type which incorporates a clean out screen.

The Part number is [1173428](#) and it replaces #PP-629.

Part number [1173428](#) is on units manufactured January 2, 1991 and after; serial numbers beginning with 91A and up. Part Number PP-629 was discontinued at the end of December 1990; serial numbers beginning with 90L and before.

Although [#1173428](#) replaces #PP-629, it is not a direct replacement. For the first change over, you need to use Kit [#4440329](#). After using this kit one time, you then will then just use [#1173428](#).

A replacement strainer screen is available for this new strainer; Part # [1173429](#).

Recap:

#PP-629	No longer available - use 173428 or 4440329	
		<u>1991 List Price</u>
#1173428	In Line Strainer	\$32.50
#1173429	Replacement Screen for 1173428	\$ 3.50
#440329	Replacement Strainer Kit to Convert from #PP-629 to 1173428	\$44.50

TE/dy

1100 Old Honeycutt Rd.
Fuquay-Varina, NC 27526
(919) 552-9161
FAX (919) 552-9798

southbend

SERVICE BULLETIN

TO: Southbend Parts & Service Distributors
FROM: Thomas S. Enyeart
Manager, Technical Services
DATE: June 10, 1991 **BULLETIN #9122**
SUBJECT: Model 2001 - New Improved Door Latch/Catch

Please insert this bulletin behind the 2001 owners manual in the ST-Steamer section of your master Southbend manual.

Effective May, 1991, serial number 91C46648 and all there after.

A new improved door latch and door catch are now being supplied on model 2001 steamers. This new design allows for improved latching action and easier, more positive alignment adjustment.

Old style parts are no longer available. The first time a change of these parts is made, you must use part #4440334 Door Latch/Catch Improvement Kit.

New Parts:

#1173531 Door Handle Assembly (replaces #6600376)
#1173530 Door Latch (replaces #6600434)
#1173529 Door Catch (replaces #132125)
#4440334 Door Latch/Catch Improvement Kit
Contains one each #1173531 Door Handle Assembly, one #1173530 Door Latch, one #1173529 Door Catch and one #1173536 Instruction sheet. These parts replace old style #6600376 Handle, 6600434 Latch and 132125 Catch.

Discontinued Parts* -- No longer available

#6600376 Door Handle Assembly (replaced by #1173531)
#6600434 Door Latch (replaced by #1173530)
#132125 Door Catch (replaced by #1173529)

* As stated before, when first changing any of these three parts, they all have to be changed by using the replacement kit or the individual parts.

TE/dy

1100 Old Honeycutt Rd.
Fuquay-Varina, NC 27526
(919) 552-9161
FAX (919) 552-9798

southbend

SERVICE BULLETIN

TO: SOUTHBEND PARTS & SERVICE DISTRIBUTORS

FROM: THOMAS S. ENYEART
MANAGER, TECHNICAL SERVICES

DATE: AUGUST 1, 1990 Bulletin 9012

SUBJECT: 2001 CONVECTION STEAMER
SPORADIC LOW WATER LIGHT
OVERHEATING ELEMENTS-POSSIBLE ELEMENT MELTDOWN

Please insert this bulletin in the ST-Steamer section of your master Southbend manual behind 2001 Convection Steamer Manual #1173012.

We have had some units where the electric elements actually melt down. In all cases the high limit control had either been adjusted or the unit had been miss-wired. If you have problems with the low water light coming on and the unit shutting down, please check, the following: DO NOT ADJUST THE HIGH LIMIT CONTROLS.

1. Check the interior cavity bottom for lime/mineral build up. If lime/mineral build up exists, clean following the instructions in the manual. Note: Lime build up acts as an insulator.
2. Be sure that during operation-the water level is at the top of the stopper to the overflow point, and of uniform depth throughout the cavity. If water level is uneven, level the unit. If the water level is not -at the top of the stopper check the following:
 - a. Be sure there is no lime build up on the stopper or the drain opening. If there is, clean following the instructions in the manual.
 - b. Be sure the stopper fits properly so the water is forced to drain over the top and not around the stopper.
 - c. Be sure water flow into the unit is sufficient to provide the proper water level. If not take what ever steps are necessary to assure same.

1100 Old Honeycutt Rd.
Fuquay-Varina, NC 27526
(919) 552-9161
FAX (919) 552-9798

August 1, 1990

Page 2

3. Check the boiling pattern of the water on the interior cavity bottom. The pattern should be in the shape of the 3 elements. If the boiling pattern is good this means the heat transfer is good. If the boiling pattern is not good there is bad heat transfer - you will probably have to remove the elements, apply a new coat of thermal grease, and then reinstall the elements. Note: The bottom must **be** flat to assure a good contact. Please refer to the manual.
4. The high limit is set to shut down the unit when the element reaches 450 degrees. (The normal operating element temperature is approximately 370 degrees). You can check the element temperature by using a temperature probe (remove element cover and go through the rear of the unit). Sense the element where the high limit bulb contacts the element.
5. Be sure the high limit sensing bulb is secure to the element.

Performing these checks should eliminate any problems and assure the unit is operating as designed.

AS previously Stated. DO NOT UNDER ANY CIRCUMSTANCES ADJUST THE HIGH LIMIT CONTROLS. Not only can this result in destruction of the unit, it nay create unsafe conditions for the user. Any person who adjusts this control will be solely responsible!

TSE/tws

S E R V I C E

southbend

B•U•L•L•E•T•I•N

TO: Southbend Parts & Service Distributors

FROM: Thomas S. Enyeart- CFSP
Director Product Service

DATE: February 7, 1994 **BULLETIN #9433**

**SUBJECT: Availability of Stainless Steel Water Jet Nozzle
Model 2001**

Effective Date: Special Part in now available

Please insert this bulletin with #[1173012](#) Counter Top Convection Steamer owners manual in the ST-Steamers-Pressure less & Pressure section of your master Southbend manual.

This new part is not a replacement of existing [6600241](#) Nozzle in standard production. It is a special Stainless Steel Jet Nozzle to be used where water conditions dictate, and is available on special request only.

New Part:

[6600241](#)-SS Stainless Steel Full Jet Nozzle

List Price – effective 1-15-94

TE/dy

southbend SERVICE B·U·L·L·E·T·I·N

BULLETIN # 9502

TO: Southbend Parts & Service Distributors

FROM: Roscoe Hester
Service Administrator

DATE: June 28, 1995

SUBJECT: **Door Spring Tool (Model 2001)**

We now supply a door spring tool to assist in installing handle springs on model 2001 (Part numbers [6600396](#) and [6600398](#)).

Part Number for door spring tool: 4440366
List Price: \$ 8.40

If you have questions, please contact the Service Department at (800) 348-2558.

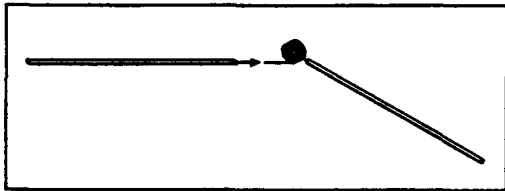

FIGURE 1

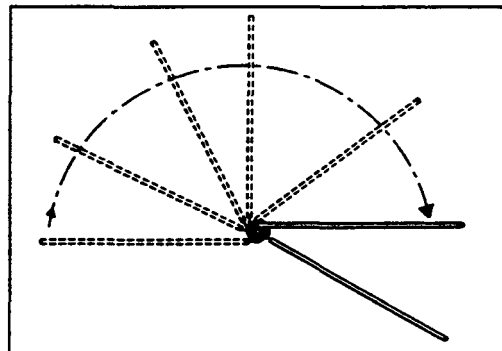

FIGURE 2

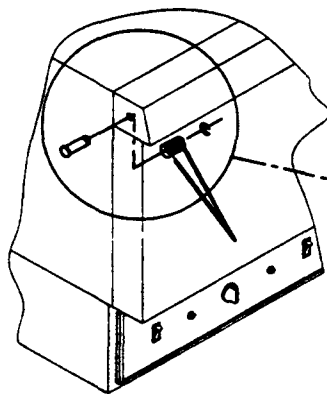

FIGURE 3

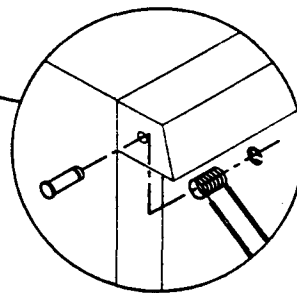

FIGURE 4

SOUTHBEND SERVICE BULLETIN

TO: Southbend Parts & Service Distributors

FROM: Thomas S. Enyeart
Manager, Technical Services

DATE: September 20, 1991

BULLETIN# 9126

SUBJECT: 2001 Convection Steamer
a) Addition of element thermostats
b) Low water light changed to trouble light

Please insert the attached revised 7 manual pages into your 2001 Counter Top Convection Steamer Owners Manual -Pt #1173012 in the ST-Steamer Section of your master Southbend manual.

Also, please correct your price list, showing the new part numbers - prices remain the same.

Effective date - August 1991 - Unit serial numbers beginning with "91H".

A major improvement has been made to the 2001 Steamer, adding disc-type fixed thermostats to the heating elements and changing the amber "low water" light to a red "Trouble" light. This change makes the unit more forgiving. The thermostats will control the element temperature still using the high limit control for a safety backup. This change will help compensate for improper installations, guards against low water almost entirely, eliminating the chance of element meltdown and warped bottoms. The new trouble light indicates a problem with the unit and that the operator should call the authorized service agency. Installation should still be made as instructed in the manual.

New parts are:

#1174302	Disc-type thermostat for element
#1174299	Wire routing support
#1174301	Wiring shield
#1174300	Wiring routing channel
#1174306	Element insulation
#1174307	Insulation cover
#1161675	Bushing
#1173537	Polypanel
#6600028	Red trouble light
#1174320	Control panel
#1174309	Relay mounting bracket

1100 Old Honeycutt Rd.
Fuquay-Varina, NC 27526
(919) 552-9161
FAX (919) 552-9798

#1170335 Terminal strip
#1174308 Retainer - High limit bulb
#1174304 Element 208V
#1174305 Element 240V

Discontinued parts are:

#6600030 Low water light - amber - still available
#1170008 Relay bracket - still available
#1168029 Element 208V - Discontinued - use 1174304
#1168028 Element 240V - Discontinued - use 1174305
#132282 Control panel - still available
#1167592 Polypanel - still available
#A19-00011Element insulation - still available

Please note new elements #1174304 S 1174305 can be used on both models using cast aluminum elements, either with or without thermostats. Old style elements 1168029 & 1168028 can only be used on units without the thermostats. The difference is the new elements are drilled and tapped to accept the thermostats, whereas the discontinued elements are not.

RECAP: The new revised steamer (Ser. 91H & up) is being manufactured with protective thermostats installed on the element body. There are 2 thermostats per element for a total of 6. These units can be easily identified in the field by the following:

1. Red "trouble" light in place of amber "low water" light.
2. Terminal strip and 3 relays in rear component area on right side of motor. Previously, no terminal strip was used and there were two relays - mounted to the left of the motor.

Under normal operating conditions, the steamer will operate with the elements on continuously. They will not cycle "off" and "on". If the interior bottom of the cooking cavity space becomes unclean due to lime or other deposits, or if the water supply to the unit is stopped or diminished, the elements may begin to cycle off and on. This condition may be recognized by reduced performance of the unit. Check and clean the interior bottom, if necessary, and check to make sure that the water supply is not restricted or turned off.

Bulletin #9126

Page 3

The "trouble" light illuminated indicates that there may be severe lime/deposits and/or restricted water supply to unit. However, this condition can only occur if the element thermostats all fail in the "on" (normally closed - "untripped" state) position.

If "trouble" light is on, a thorough investigation must be done to determine the cause of the problem. Please consult a Southbend service representative at the factory if you need assistance in determining the problem.

TE/dy

southbend SERVICE BULLETIN

Date: September 22, 1988

To: Southbend Authorized Service Representatives And Parts Distributors

Subject: 2001 Steamer Door Slide Pivot Kit

Please insert in the CS-Convection Steamer section of your Master Southbend Manual

A major improvement that has been made on the door slide pivot. The old style clip has been eliminated by the use of a pivot and a screw. These are in production and field use has proven very satisfactory. To improve the older units and to reduce inventories Part #132-312 door slide pivot kit is now available (Instruction sheet reprinted on rear of this bulletin). This parts kit #132-312 replaces any and all of the following:

Pivots	#132-238 132-027-2 132-309 A81-00049 1167264 6600404
Clips	#PH-301 PH-307 PH-317 1167265 6600402
Screw	#PH095

This is a Mandatory Distributor Stock Item



T5. Enyeart
Manager - Parts & Service

TSE/kj

Southbend Sales Representatives

Internal Distribution

1100 Old Honeycutt Rd.
Fuquay-Varina, NC 27526
(919) 552-9161
FAX (919) 552-9798

P.N. 132-312 " DOOR SLIDE PIVOT KIT

OLD STYLE → REPLACE WITH → NEW STYLE

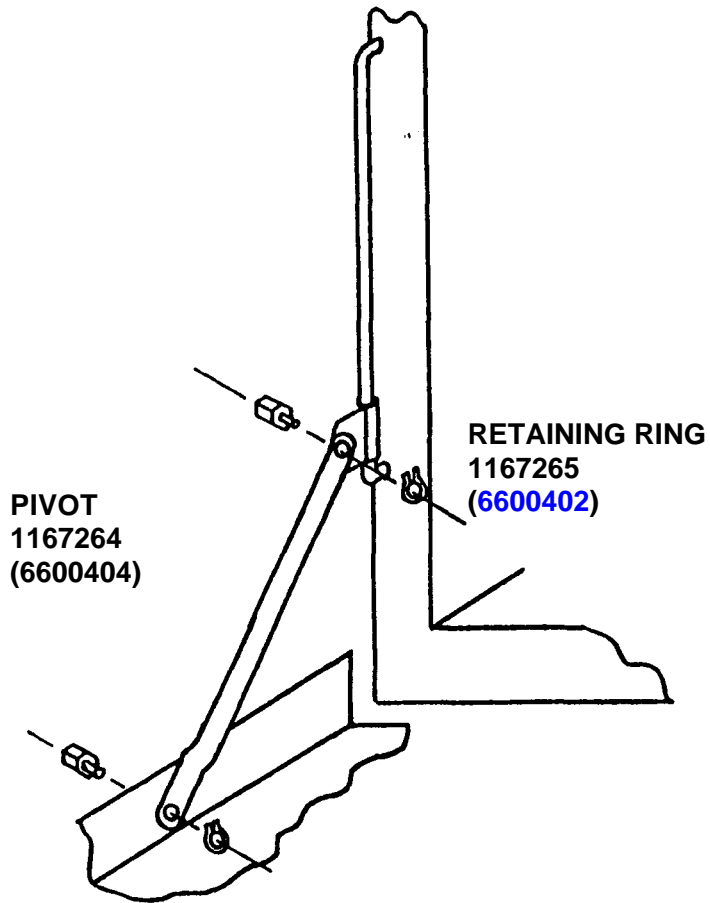

Old styles using Pivot and Retaining Ring are replaced by #132-312 Door Slide Pivot Kit.

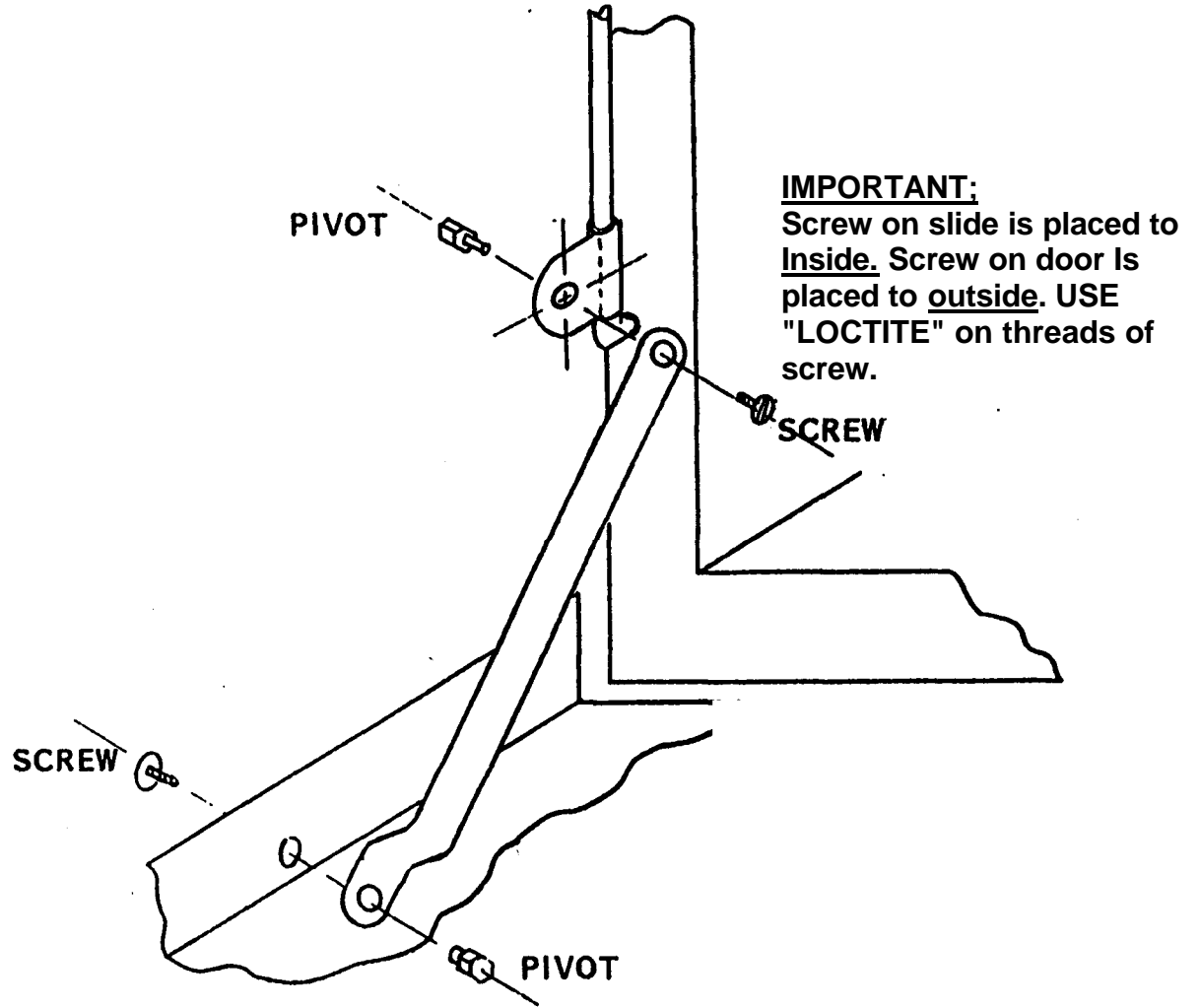

NOTE: For units with Serial numbers before 807-18 enlarge holes with 21/64th drill.

southbend SERVICE BULLETIN

Date: August 29, 1988

To: ALL SOUTHBEND AUTHORIZED SERVICE AGENCIES AND PARTS DISTRIBUTORS

Subject: 2001 Dual Power Steamers
Intermittent Element Drop Out, Low Water Light Coming On

Please insert in the CS-Convection Steamer Section of your Master Southbend Manual.

On a few 2001 New Style Dual Power Steamer we have had sporadic reports of the high limit control switching on causing the Elements to drop out and the low water light to come on.

If you encounter these symptoms on this unit, the following will normally solve the problem. Complete steps as necessary to eliminate the problem.

1. Check the high limit control.
2. Check the physical condition of the elements. Make certain they are intact and in good array.
3. Make certain that all nuts that hold the elements in position are tight. Care should be taken not to break the weld stud (Do Not tighten over 75 inch lbs.)
4. Remove the elements and make sure there is no weld splatter around the studs to hold elements from fitting flush to the bottom plate of the steamer - If there is splatter then carefully remove before replacing elements.

IF ELEMENTS HAVE TO BE REMOVED FOLLOW THE ATTACHED- INSTRUCTIONS.

PART NO. PN-126 Thermo Coat may be ordered thru our Parts Department.

1100 Old Honeycutt Rd.
Fuquay-Varina, NC 27526
(919)552-9161
FAX (919) 552-9798

THERMOCOAT INSTRUCTIONS - 2001 DUAL POWER STEAMER

READ THE ENTIRE PROCEDURE CAREFULLY BEFORE STARTING ANY WORK

1. Disconnect all power, water and drain lines to the unit.
2. Turn unit upside down.
3. Remove bottom aluminized panel and aluminum back.
4. Make a general inspection of this area looking for any heat damage or lime deposits from leaky inlet water connections.
5. Carefully start to un-tighten the 1/4-20 nuts which hold Item 3 in place.
6. Disconnect and remove the copper water line to the condenser.
7. Item 3 can now be removed, however caution should be used here because the insulation underneath is brittle and can be damaged.
8. Remove the insulation surrounding the heating elements Items 4, 8, and 9. Here again be very gentle considering the brittleness of the insulation.
9. The heating elements are now exposed inspect elements and wiring for damage.
10. Remove high limit thermostats very carefully taking extra care not to put any crimps in the bulb or tube.
11. Carefully remove the nuts and washers. Note that washers are cupped. The application of some lubricate like penetrating oil before untightening is advisable.
12. If any of the studs have broken away from the bottom carefully reinstall all parts and return to factory.
13. Remove heating elements, being careful not to use the portion of the element extending from the aluminum casting as a hand hold. (Note present position of elements.)

14. Thoroughly clean the heat conducting paste from the heater and its mating surface. Inspect the element and mating surface for flatness using a good straight edge. If when checking the flatness of the mating surface a gap greater than 1/16 in depth and 2 inches long is detected consult the factory for additional instructions.
15. Coat the underside of the heating element with a coat of heat conducting paste approximately 1/32 to 1/16 in depth across the entire surface making sure there are no voids or air pockets.
16. Reinstall the heating elements in the same position they were removed. Install washers so cups are facing each other leaving a small gap in center of washers. Refer to drawing one. When tightening, tighten diagonally to no more than 50 in-lbs on the first pass. On the second pass tighten diagonally to 75 in-lbs then go back over each nut in reverse order.
17. After all heating elements have been installed go back over each nut and tighten to 75 in-lbs.
18. Reconnect wiring to heating elements per wiring diagram.
19. Reinstall high limit thermostat making sure that the bulb is laying flat on the heater and is securely fastened. It may be necessary to bend slightly the washer which holds the bulb down. The bulb should not be loose in its holder.
20. Reinstall insulation again being very careful not to damage it. Replace any broken pieces.
21. Reinstall cover Item 3. The nuts which hold the cover on also hold the heating element in place and should be tightened as described earlier.
22. Reinstall copper water line to condenser.
23. Replace bottom return unit to normal operating position.
24. Hooking water, power and drain lines install back.
25. Turn unit on and check for proper operation.

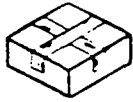

PARTS

CONDENSOR

KEY NO.	PART NO.	DESCRIPTION
1	130-283	CONOENSOR - COMPLETE (A12-0027)
2	130-225	HOLDING RING - NOZZLE <6600325>
3	PP-632	SPRAY JET NOZZLE (6600241)
4	PP-247	COUPLING (A98-00003)
5	PH-003	SCREW (6600540)
6	PH.277	LOCKWASHER (6600541)
7	130-169	TEFLON GASKET - DRAIN (6600316)

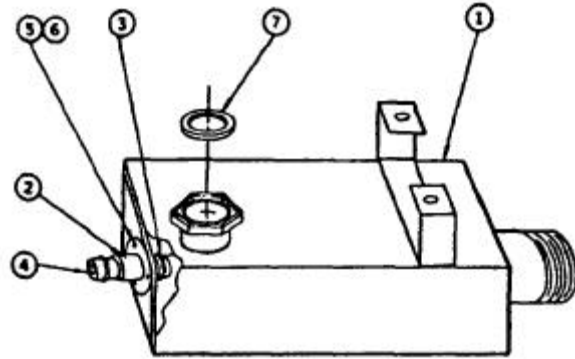

MOUNTING VIEW - ELEMENTS (208V,220V,240V)

KEY NO.	PART NO.	DESCRIPTION
1	PH-202	NUT- ¼ -20 (1146413)
2	PH-251	LOCKWASHER - 1/4- (1146500)
3	132-295	COVER - INSULATION ELEMENT (A14-00026)
4	132-294-1	INSULATION - ELEMENT (A19-00011)
5	1-0574	SPRING WASHER (A60-00004)
6	132-296	WASHER - LIMIT THERMOSTAT (A60.00005)
7	132-264-1	HEATING ELEMENT (208V) (1168029)
	132-264-2	HEATING ELEMENT (240V) (1168028)
8	132.294-3	INSULATION - FRONT & REAR (A19-00012)
9	132-294-2	INSULATION - SIDE (A19-00013)
	PM-140	THERMO JOINT COMPOUND FOR ELEMENTS (202)

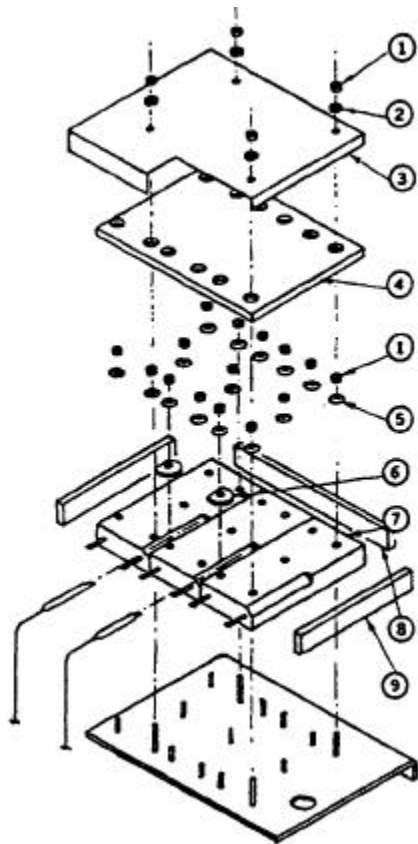

MISCELLANEOUS PARTS NOT SHOWN IN PHOTOS OR DRAWINGS

KEY NO.	PART NO.	DESCRIPTION
	132-105-1	DOOR CATCH SPACER (6600509)
	132-033	DRAIN PAN (6600454)
	PM-015	STEEL LEG ASSY - (OPTIONAL)
	6600362	- ONE (6600361)
		-SET Of 4

southbend SERVICE BULLETIN

AUTHORIZED PARTS DISTRIBUTORS & SERVICE AGENCIES
2001RL DOOR SLIDE CLIPS

September 30, 1986

Please insert in the CS - Convection Steamer Section of the master Southbend Service Manual. Replaces Bulletin dated 7-16-86. Destroy 7-16 bulletin.

Due to heavy usage the slide clip which is welded to the slide arm **can** become damaged. In the past it was suggested that the slide arm assembly be cut off and a new assembly be welded to the unit.

Effective immediately a new clip is available that can be slipped on over the slide arm. It is necessary to cut the old clip off with a hacksaw.

Once the new clip is in place squeeze the clip together with a pair of vise grips and assemble to the slide arm with a 10-24 pan head bolt and nut. Be sure to use a jam nut to ensure that the nut remains in place.

Also the head of the bolt should face the interior of the unit to minimize damage to the gasket. See Below.

Kit Part No. **A81-00004** - Slide Clip Kit (consists of slide clip #**A34-00001**, one 10-24 pan head bolt #**1146238**, two 10-24 nuts #**1146412**). Current list price \$5.00.

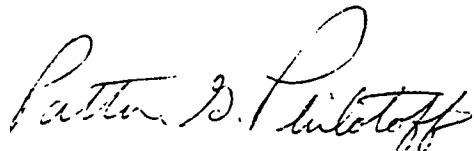

Patton G. Philotoff
Regional Service Manager

cc. Sales Directors
Sales Representatives
Internal Distribution

Top View



Snap Slide Clip over Slide Rod

Body of Unit

Hold Slide Clip with Vise Grips here

Side View

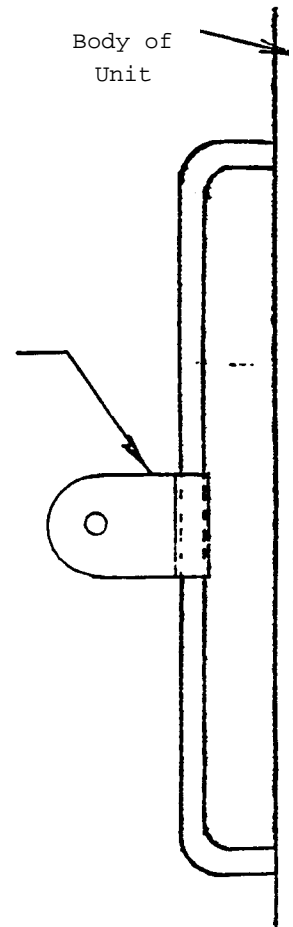

1100 Old Honeycutt Rd.
Fuquay-Varina, NC 27526
(919)552-9161
FAX (919) 552-9798

COUNTER TOP CONVECTION STEAMER INSTALLATION

SPECIFICATIONS

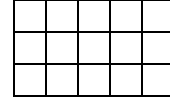

Not For Scale
For Dimensional Purposes Only

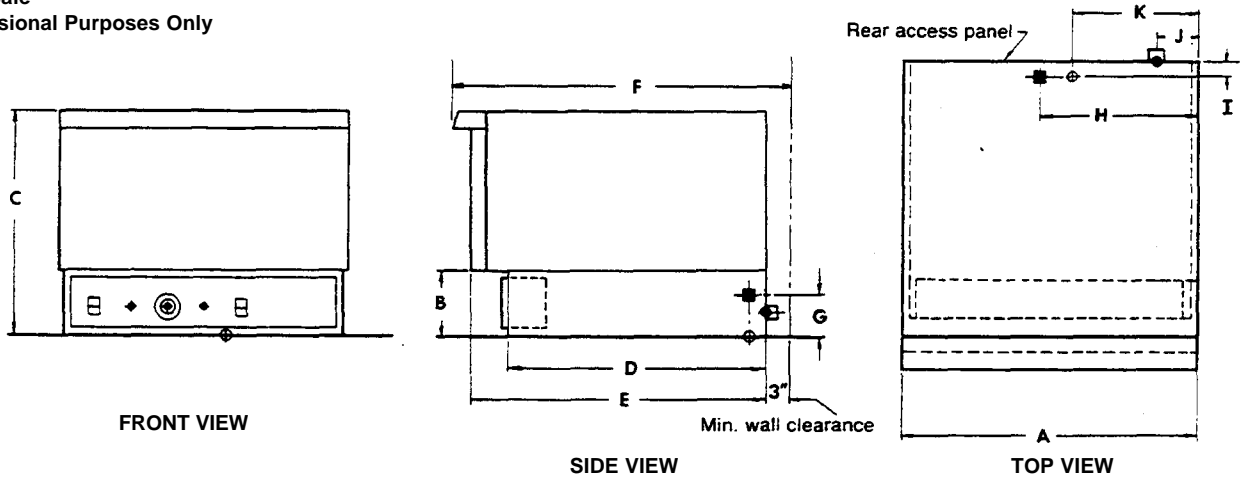

- Electric connection - terminal block.
- ◆ Drain 1 1/4" o.d., leave open, do not connect to floor drain.
- ⊕ Cold water inlet 1/4", 30 p.s.i. min. - 60 p.s.i. max.

DIMENSIONS:

() = Millimeters

MODEL	Width A		HEIGHT		DEPTH			ELECTRIC CONN.			Drain J	Water K	CRATE SIZE			Cubic Volume	Crated Weight
	B	C	D	E	F	G	H	I	Width	Depth			Height				
2001	24" (610)	5.5" (140)	18.3" (465)	21.5" (546)	23.8" (605)	25.25" (610)	3.5" (89)	13" (330)	1.5" (38)	3.5" (89)	10" (254)	26.5" (673)	29.5" (749)	26.5" (673)	12 cu. ft. .34 cu.	155 lbs. 70.3 kg.	

UTILITY INFORMATION:

ELECTRIC: 208/60/1, 240/60/1, 208/60/3, or 240/60/3.

TOTAL CONNECTED AMPS

208/240 V
9.5 KW*

- 208/60/1
- 208/60/3
- 240/60/1
- 240/60/3

46
30
41
25

*Circuit must be wired for maximum 9.5 KW at required voltage.

WATER USAGE: 0.20 gallons per minute at 45 p.s.i. water pressure.

APPROVALS:





INSTALLATION

GENERAL:

THE UNIT WHEN INSTALLED MUST BE ELECTRICALLY GROUNDED AND COMPLY WITH LOCAL CODES, OR IN THE ABSENCE OF LOCAL CODES, WITH THE NATIONAL ELECTRICAL CODE ANSI/NFPA 70-Latest Edition.

CANADIAN INSTALLATION MUST COMPLY WITH Canadian Electrical Code, Parts I and II.

CLEARANCES:

Allow at least a three inch (3") 76 mm. clearance between the back of the unit and any wall obstruction for proper ventilation of the motor compartment, and room for plumbing and electrical connections.

Do not locate the Southbend Steamer adjacent to any high heat-producing piece of equipment, such as a range top, griddle, fryer, etc., that could allow radiant heat to raise the exterior temperature of the Southbend Steamer above 130T (54°C).

WARNING:

THESE PROCEDURES MUST BE FOLLOWED BY QUALIFIED PERSONNEL OR WARRANTY WILL BE VOIDED.

TO INSTALL:

1. Uncrate carefully. Report any hidden freight damage to the freight company immediately.
2. Do not remove any tags or labels until the unit is installed and working properly.
3. Set unit in place.
4. **Counter Model** — Set on non-flammable surface and shim to make level. Seal to counter top with sealer such as G. E. or DOW Coming RTV type sealant. (Consult local code for exact requirements.)

LEVELING:

1. Unit must be level to assure maximum performance. Improper leveling may void warranty.

WATER CONNECTION:

Connect cold water line, 1/4" (6mm.) pipe. *Do not connect to hot water source. (Connecting hot water may void the warranty.)* Water line pressure should be 30 psi (205 Kpa) minimum — 60 psi (410 Kpa) maximum.

NOTE: To facilitate cleaning, plus allowing access to the rear of unit, flexible connections are recommended.



DRAIN LINE:

Type A: Drain line to unit requires 1 ¼" (32 mm.) pipe. Unit should be positioned near an open floor drain. There must be no plumbing connection to a drain system. The unit must be free-venting to atmosphere. The drain line should be as short as possible (no longer than 40" (1016 mm.) to the "FUNNEL," and at a slope of at least 15°. Any connection that allows the build-up of back pressure in the unit will void the warranty. This is a pressureless, free-venting steam cooker and will not operate properly unless the drain line is short, at a steep angle, and open!

Type B: Drain line to unit requires 1" (25 mm.) pipe. Unit should be positioned near drain. The drain line can be connected to drain, but must have a vent pipe extending upward from the "T" connection.

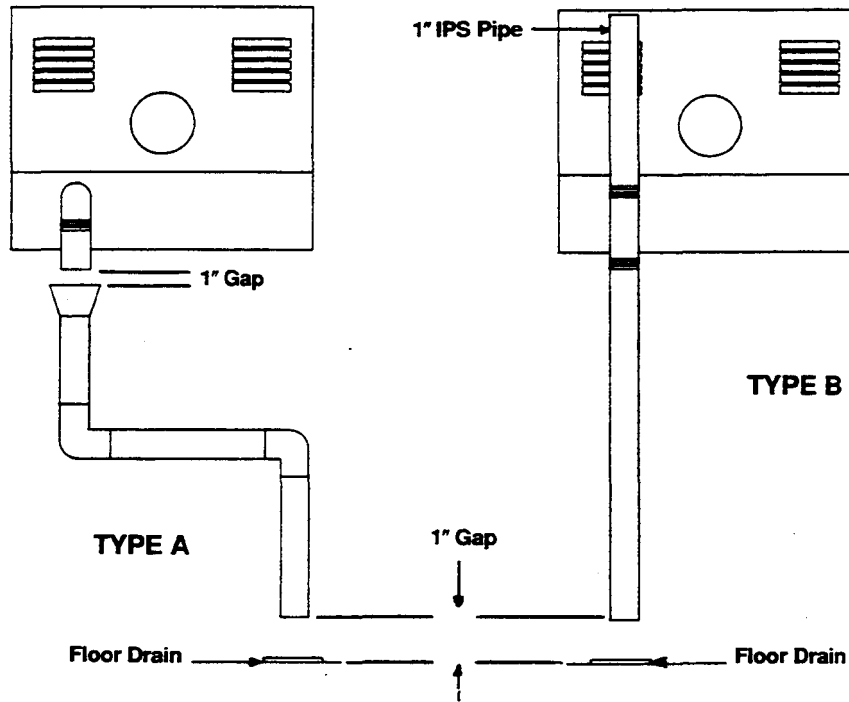

ELECTRICAL CONNECTION:

For proper connection of field wiring to terminal block, see Wiring Diagram, Section 3, Page 7. Be sure that the input voltage and phase match the requirements shown on the serial plate (located on each piece of equipment). **NOTE: A POSITIVE GROUND CONNECTION IS ESSENTIAL.**

NOTE: ALL Steamers are shipped wired for three phase. To convert to single phase see Section One, Page 4.

DO NOT ALLOW ANY TAMPERING OR ADJUSTMENT OF ANY CONTROL OR WIRING. THE UNIT IS FACTORY SET. ADJUSTMENT OF ANY INTERNAL COMPONENT OTHER THAN THE FIELD TERMINAL BLOCK CAN VOID THE WARRANTY.

1. Open water valve to full open position.

CHECK:

- a. Power to unit.
- b. Water to unit.
- c. Open drain.



INSTALLATION

NOTE: ALL Steamers are shipped three phase. If it becomes necessary to convert from three phase to single phase follow instructions below.

1. Remove louver panel from rear of steamer
2. Locate contactor in right hand side of rear control compartment and loosen wire terminals on the output side of contactor.
3. Move wire number 3 from A3 to A1. Refer to diagram below.
4. Move wires number 5 and 6 from A2 to A3. Refer to diagram below.
5. Tighten all wire terminals and replace louver panel. The unit is now converted from three phase to single phase.

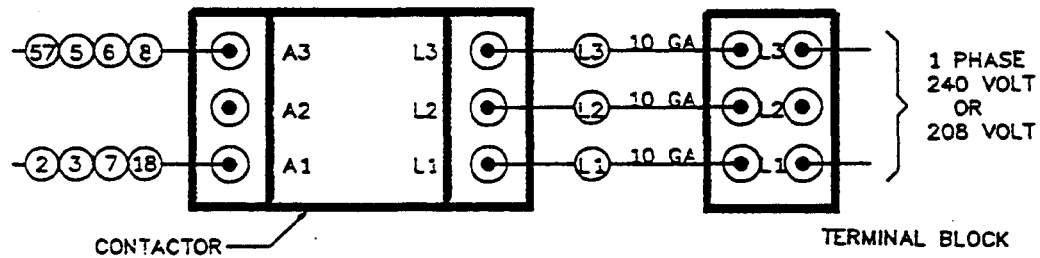
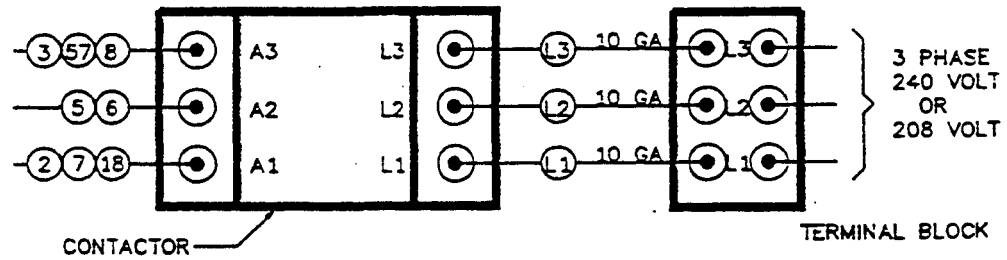



INSTRUCTIONS FOR STACKING THE 2001:

1. Center one of the 2001s on top of the other, making sure the back bottom corners of the top unit line up with the back top corners of the bottom unit.
2. Using a felt tip pen, trace around the top unit.
3. Remove the top unit. Spread a bead of high temperature silicone, about the diameter of a pencil, inside the line drawn in No. 2.
4. Carefully place the top unit on the bottom unit. Seal around edges with silicone to comply with NSF requirements.
5. To install brackets, remove the screws that fasten the bottom plate to the back of the unit. These screws are 3" from each corner. The hook on the bracket should slide over the lip on the very top of the bottom unit. It may be necessary to push in slightly on the back louvered panel to allow room for the brackets. Reinstall the screws through the bracket.
6. Allow 24 hours for silicone to dry before using units.

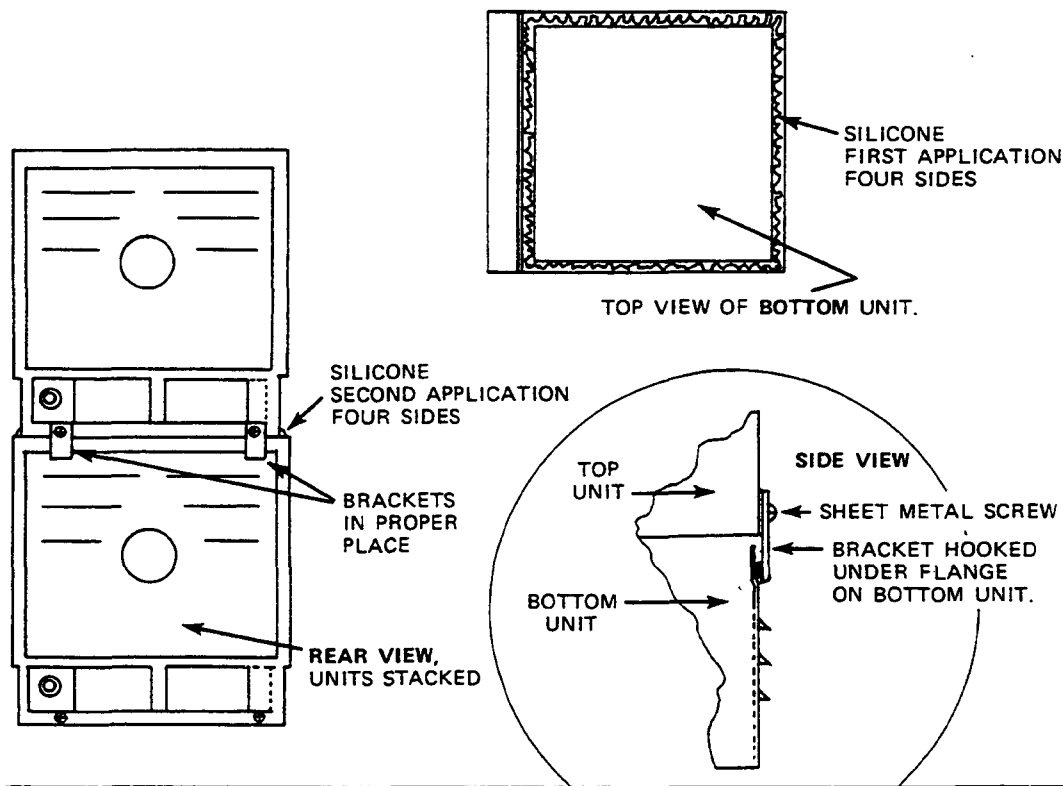

PERFORMANCE CHECK:

The following items should be checked before or within the first 30 days of operation by a qualified service technician.

1. Check doors for proper alignment and tension.
2. Check door gaskets for wear and sealing ability.
3. Check spray tubes or nozzles for cleanliness and/or leakage.
4. Check all gauges, timers, valves, switches, and motors for proper operation.
5. Visually check control compartment wiring for burned or loose connections.
6. Is user keeping compartment clean?
7. Check electrical load on elements, where applicable, for proper wattage.

COOKING HINTS



SUGGESTED COOKING TIMES:

Timer settings are for general guidance only. Differences in food quality, size, shape, freshness, load size and degree of cook desired must be considered and adjustments made in time if necessary.

PRODUCT	BATCH SIZE	APPROX. COOKING TIME (MIN)	PRODUCT	BATCH SIZE	APPROX. COOKING TIME (MIN)
FROZEN VEGETABLES*			FRESH VEGETABLES*		
ASPARAGUS			BROCCOLI		
Cuts and tips	5 IDS.	8-10	Spears	4 lbs.	12-14
Spears	5 IDS.	10-12	BEANS		
BEANS			Green, 1 "-2" cut	5lbs.	13-15
Green or wax - cut 1"	5 IDS.	14-16	BRUSSEL SPROUTS		
Green - French cut	5lbs.	20-22	Small	5lbs.	12-14
Lima - Fordhook	5lbs.	16-18	Large	5lbs.	16-18
BROCCOLI			CABBAGE		
Chopped - tempered	4 IDS.	8-10	Green - shredded	5lbs.	12-14
Cut - tempered	5lbs.	8-10	Green - wedges, 1/6 cut	5lbs.	20-22
Spears	4 IDS.	10-12	Red - shredded	5lbs.	18-20
BRUSSEL SPROUTS	4 IDS.	8-10	CARROTS		
CARROTS			Sliced - 1/2"	7 lbs.	17-19
Sliced	4 IDS.	10-12	CAULIFLOWER		
Whole, baby	5lbs.	14-16	Flowerettes	6 lbs.	14-16
CAULIFLOWER			CELERY		
Flowerettes	4 IDS.	8-10	1 "-2" cuts	5lbs.	14-16
CORN			3"-4" cuts in solid pan w/chicken broth added	5lbs.	14-16
Cobettes - 3"	27	14-16	CORN		
Whole Kernel	5lbs.	10-12	On the cob		
MIXED VEGETABLES	5lbs.	16-18	5"-7" length 1	14 ears	13-15
PEAS	5lbs.	10-12	On the cob 1	14 ears	
POTATOES			5"-7" length, 2 pans e	ea. pan	18-20
White, whole, small	5 lbs.	18-20	PEPPERS		
SPINACH			Green, large, cut side down	14 halves	5-7
Chopped - tempered	6 IDS.	8-10	POTATOES		
Leaf - tempered	6 lbs.	18-20	Red boilers, whole, peeled, 1 "-3"	7 lbs.	25-30
SUCCOTASH	5lbs.	16-18	Red boilers, whole, peeled, 1"-3", 3 pans	7 lbs. ea. pan	45-50
ZUCCHINI			SPINACH		
Sliced - tempered	6 lbs.	8-10	Leaf	2 lbs.	4-5
			SQUASH		
			Zucchini, sliced, 3/16"	5lbs.	7-8
			Zucchini, sliced, 3/16" - 2 pans	5lbs. ea. pan	12-13
*Prepare in 12 x 20 x 2 1/2" perforated pan.					



COOKING HINTS

PRODUCT	BATCH SIZE	APPROX. COOKING TIME (MIN)	PRODUCT	BATCH SIZE	APPROX. COOKING TIME (MIN)
FRUIT			PASTA		
CRANBERRIES Fresh-12 x 20 x 2 ½" solid pan - use 3 cups water and 5 cups sugar	4 lbs.	8-10	Prepare in 2 ½" deep perforated pan nested inside solid 12" x 20" x 4" pan. Cover with hot tap water. Add salt and oil if desired and stir. Stir again halfway through cooking cycle.		
PRUNES Dried and pitted - 12 x 20 x 2 ½" solid pan - add 4 cups hot water and sugar to taste	4lbs.	8-10	SPAGHETTI Semolina 2lbs. 12-14 MACARONI Semolina 2lbs. 18-22 NOODLES Egg, Semolina 2lbs. 12-14 Lasagna, Semolina 2lbs. 15-18		
RICE AND DRIED BEANS			EGGS		
Prepare in 12" x 20" x 2 ½" solid pan unless otherwise indicated. Add hot tap water; salt and oil as desired. Stir before placing in steamer. Do not cover.			Prepare in 12" x 20" x 2 ½" perforated pan, unless indicated. Remove eggs from refrigerator 1 hour prior to cooking.		
WHITE LONG GRAIN CONVEF 2 ½ quarts water, salt, oil 6" deep pan, 6 ½ quarts water	TTED 2 lbs. 6 ½ lbs. (1 gal)	30-35 40-45	SOFT COOKED Large 4 doz. 8-10 HARD COOKED Large, in shell Large, cracked into oiled solid pan - for salad 4 doz. 12-14 4 doz. 10-12		
WHITE MEDIUM GRAIN 1 ¾ quarts water	2 lbs.	22-25	SCRAMBLED Add margarine and spices if desired. Stir with wire whip after 15 minutes. 4" solid pan. Mixture in 5-lb. poly film bag, frozen. Cover with hot water in 4" pan. Stir after 25 min. 2 bags 45-50		
BROWN LONG GRAIN PARBO 1 ½ quarts water 1 ½ quarts water, 2 pans	ILED 1 ¾ lbs. 1 ¾ lbs. ea. pan	25-30 30-35	POACHED In poaching pan or water 8 3-4		
WILD EXTRA FANCY 5 cups water	1 lb.	60-65	POULTRY		
KIDNEY BEANS 4 quarts hot water. Steam 4 minutes. Remove; cover; let stand one hour. Remove cover. Continue steaming.		4-50	Prepare in 12" x 20" x 2 ½" perforated pan. Place solid pan underneath to catch juice.		
NAVY BEANS 3 quarts hot water. Steam 2 minutes. Remove; cover; let stand 1 hour. Remove cover. Continue steaming.	2lbs.	2-50	CHICKEN Whole, as purchased 4lbs. 40 Quarters, 8-9 oz. 14 pcs. 18-20 Quarters, 8-9 oz., 2 pans 14 pcs. 24-27 ea. pan		

COOKING HINTS



PRODUCT	BATCH SIZE	APPROX. COOKING TIME (MIN)	PRODUCT	BATCH SIZE	APPROX. COOKING TIME (MIN)
MEAT			MISCELLANEOUS		
Prepare in 12" x 20" pan - depth as indicated.			CHEESE SOUP		
BEEF			Frozen, 12" x 20" x 6" pan. Water or milk added. Stir at 15 and 30 minutes.		
Clod - 4" solid pan; add 1" water. Cook to 180° internal temperature	15-17 lbs.	13-15 per lb.	Two 4-lb. tubs		40
Ground - 4" solid pan. Stir at 30 minutes.	10 lbs.	40	BLANCHING NUTS		
CORNEDED BEEF BRISKET			Steam in solid pan with 1 cup water.		
Raw - cured, 2 ½" solid pan; add ½" water.	9 lbs.	18-22 per lb.	DINNER ROLLS		
HOT DOGS			Pre-baked, frozen. Reheat in perforated pan or on pan shelf, uncovered.		
2 ½" perforated pan, thawed	5 lbs.	5	TORTILLAS		
2 ½" perforated pan, frozen	5 lbs.	10	Slightly overlap on perforated pan or on pan shelf.		
FISH			6-8		
Prepare in 12" x 20" x 2 ½" perforated pan. Place solid pan underneath to catch juice.			8oz.		
COD PORTIONS			1-2		
Thawed - 4 oz. size	3 lbs.	8-10	SPAGHETTI		
OYSTERS			Cooked. To reheat place in perforated pan or strainer.		
In shell - 18-20 per pan	1 pan	12			
In shell - 18-20 per pan	3 pans	15-20			

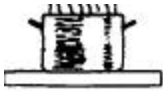

COOKING HINTS

END USER TIPS:

Schedule cooking of fresh vegetables so that they will be served soon after they are cooked. If it is necessary to prepare them in advance, they can be plunged into cold water, drained thoroughly and held under refrigeration until needed for service.

Five pounds of cold cooked vegetables can be reheated in the steamer in 5 to 10 minutes, depending upon the variety.

Adding salt to the water for eggs cooked in the shell makes the cooking water more efficient and faster at its job. If the egg cracks, the white is cooked at the crack and is sealed right away.

To avoid the dreaded green yolk (which is a deposit of iron sulfide) chill the eggs immediately after removing from the steamer by plunging them into a cold water bath (preferably containing ice).

A quick and easy way to cook eggs for a salad mixture is to crack them directly into a solid steam table pan which has been lightly coated with salad oil. *Do not mix*. Steam until they are hard cooked. Remove and chop as you would for egg salad. The job of peeling has been eliminated.

Transfer steamed hot chicken to deep pan, cover with Cacciatore Sauce and finish in Marathoner oven. Bake 20 to 30 minutes. May be held on steam table.

After cooking, chicken may be browned in Infra-Red or Radiant Broiler. Brush with melted margarine mixed with salad oil to give a golden brown color.

Use juice saved from steamed chicken to make soups, sauces, or casserole dishes.

Chicken may be steamed in advance and held under refrigeration for next day's use. Be sure to bring product back to 180 °F before serving.

Save the juice from the corned beef. After the cabbage has been steamed, place it in a solid pan and add the juice for flavoring and holding on a steam table.

Steaming brisket in the 2001 Steamer is a definite time saver. Boiling in water takes 40 to 50 minutes per pound. Using the 2001 can save 50% in cooking time.

Cabbage when steamed, retains its color and wedge identity. It will not break apart as it does when boiled in an open pot.

When open, the door can be used as a convenient pan holder while seasoning, loading or unloading.

When removing items prepared in a perforated pan put a solid pan on the door shelf to hold the pan of cooked food. This will prevent dripping on the floor.

The 2001 is designed to accept standard 12 x 20 pans the way you naturally carry them. Fractional size pans can be used as well with the optional perforated shelf.

For stirring, the pan does not have to be removed from the steamer. Pull pan 1/3 way out of the cavity and the entire surface is accessible.

The door may be opened at any time during operation to remove or add food.

Possibility of overcooking is eliminated during the automatic cycle because the elements shut off when the buzzer sounds.

COUNTER TOP CONVECTION STEAMER SERVICE

ADJUSTMENTS



WARNING:

ADJUSTMENTS AND SERVICE WORK MAY BE PERFORMED ONLY BY A QUALIFIED TECHNICIAN WHO IS EXPERIENCED IN, AND KNOWLEDGEABLE WITH, THE OPERATION OF COMMERCIAL COOKING EQUIPMENT, HOWEVER, TO ASSURE YOUR CONFIDENCE, CONTACT YOUR AUTHORIZED SERVICE AGENCY FOR RELIABLE SERVICE, DEPENDABLE ADVICE OR OTHER ASSISTANCES, AND FOR GENUINE FACTORY PARTS.

The following is a brief explanation of the operation of your Southbend Series 2001 Electric Convection Steamer. The unique design of the Southbend Convection Steamer allows you to cook with steam without the problems of bulky, troublesome steam boilers. The Southbend 2001 Dual Power Series uses 9.5 KW or 6.5 KW (your choice). The Southbend Steamer generates its own steam on the bottom of the cooking compartment.

With the selector switch in the "OFF" position, you should have AC across selector switch. If not, check fuse.

When selector switch is placed in the "LO" or "HI" position and second one to "MANUAL" position, voltage is applied to the coil of contactor from line 4 at terminal block; through fuse; through both selector switches; through safety thermostats; through relay. Voltage is also applied to water solenoid. Solenoid furnishes 3/8" water (overflow drain installed) to the floor of the cooking compartment, which turns to steam when heating elements get hot. Heating elements are fastened directly under the floor of the cooking compartment and heat the water through direct conduction.

NOTE: From a cold start, the unit should be up to temperature within 4 to 5 minutes.

When contactor energizes, the higher rated voltage is applied to heating elements through the closure of contactor contacts L₁, L₂, and L₃; from the LINE voltage at terminal block.

NOTE: Interior element also cycles in parallel with heating elements.

Interior element super-heats and dehumidifies the steam in the cooking compartment.

NOTE: The fan will not operate if the door is open, due to safety interlock door switch.

Anytime the unit is turned "ON," a small amount of water will be noticed coming out of the drain-line. This is due to a "water mist," which is sprayed across the exhaust of the cooking compartment. This eliminates any possibility of "live" steam ever reaching a drain line. This feature is required by law on ALL pressure less, atmospheric steamers.

NOTE: The water connection into any Southbend Steamer must be cold water.

FOR REPLACEMENT OF HEATING ELEMENTS (See Drawing on Parts Page 4):

For units without thermostatic element control — Serial Number 91G and before.

A. REMOVAL OF ELEMENTS:

1. Close water valve and remove power to the unit.
2. Disconnect field connection to unit.
3. Remove bolts holding unit to table or stand.
4. Turn the unit on its side and remove bottom cover by sliding it toward the rear.
5. To facilitate work, unscrew control panel and electric box and pull out from their position with disconnecting any wire. Then disconnect 1/8" copper tubing from condenser.
6. Remove the four nuts, lockwashers, element cover and insulation.
7. Remove all nuts, spring washers and bulbs between elements.
8. Disconnect and remove defective elements. *Note carefully where each element is connected.*



ADJUSTMENTS

FOR REPLACEMENT OF HEATING ELEMENTS (See Drawing on Parts Page 5):

For units with thermostatic element control — Serial Number 91H and after.

A. REMOVAL OF ELEMENTS;

1. Close water valve and remove power to the unit.
2. Disconnect field connection to unit.
3. Remove bolts holding unit to table or stand.
4. Turn the unit on its side and remove bottom cover by sliding it toward the rear.
5. To facilitate work, unscrew control panel and electric box and pull out from their position with disconnecting any wire. Then disconnect 1/8" copper tubing from condenser.
6. Disconnect wires from thermostats and set loose wires aside.
7. Remove the four nuts, lockwashers, element cover and insulation.
8. Remove all nuts, spring washers and bulbs between elements.

B. INSTALLATION OF NEW ELEMENTS (See Drawing on Parts Page 4):

For units without thermostatic element control — Serial Number 91G and before.

9. Make sure the new elements are of correct voltage. Voltage marked on elements must be exactly the same as marked on the nameplate of the unit.
10. Completely coat the machined side of the element with #PN-126 thermal grease. (Failure to do so will result in inadequate heat transfer from the element into the steamer bottom plate, causing the low water light to come on.)
11. Before installing elements make sure to have clean surfaces (on stud plate and elements) except the white thermo grease.
12. Reinstall elements. Markings should be visible.
13. Install bulbs, flat washers, spring washers and nuts. A maximum of *70 inch/pounds torque* should be on nuts.
14. Connect the new elements in accordance with the wiring diagram.
15. Place the insulation over and around. Use a new insulation if the original one is broken.
16. Place the element cover over the insulation plate with lockwashers and four nuts.
17. Install the bottom cover and turn the unit on its base.
18. Fasten the unit to stand or counter top and seal to the counter top.
19. Connect field wiring and water line and open water valve.
20. Connect drain extension if so equipped, making sure that drain vents freely.
21. Reset power to the unit, turn unit ON and test amperage on each phase and each element. **R**

INSTALLATION OF NEW ELEMENTS (See Drawing on Parts Page 5):

For units with thermostatic element control — Serial Number 91H and up.

9. Disconnect and remove defective elements. Note locations of wires.
10. Make sure the new elements are of the correct voltage. Voltage marked on elements must be the same as marked on unit serial plate.
11. Completely coat the machined side of the element with PN-126 thermal grease. Failure to do so will cause inadequate heat transfer and may severely damage unit.
12. Before installing elements, make sure bottom surface is clean.
13. Reinstall elements. Markings should be visible, (rough side).
14. Install hi-limit bulbs, flat washers, spring washers and nuts. Torque securing nuts to 70 in/lbs.
15. Install (2) new thermostats on new element, tighten snug to casting surface.
16. Reinstall the element insulation board. Use new insulation if broken.
17. Connect the wires back to the elements per the wiring diagram.
18. Reinstall the sheet metal insulation cover and securing nuts.
19. Reinstall thermostat wires to thermostats. Refer to wiring diagram or sticker inside lower side panel.
20. Install the bottom cover and turn unit on its base.
21. Fasten unit to stand or countertop.
22. Connect field wiring and waterline. Open water valve.
23. Connect drain piping.
24. Reset power to unit. Turn unit on and check amperage on each leg of supply wires.

**FOR REPLACEMENT OF MOTOR (Disconnect Electric Field Connections):****A. REMOVAL OF FAN:**

1. Remove plastic plug and set screw on the fan hub. An adhesive (LOCTITE or equivalent) may have been used to prevent loosening of set screw. In such case, the set screw may have to be heated to soften the adhesive and allow removal. An electric soldering iron or gas soldering torch may be used.
2. Insert a bolt one inch (25 mm) or longer into the threaded hole at the end of the fan hub. Tighten the bolt against the end of the motor shaft until fan slips off.

Caution: *If fan does not move on shaft while tightening the bolt against the end of the motor shaft, spray penetrating oil (WD-40 or equal) into plug and set screw holes every few minutes until fan can be removed without damage.*

R REMOVAL OF MOTOR:

3. Remove seal and clean shaft.
4. Remove electric wires from motor. Note which terminals the wires were attached to. Incorrect wiring could damage the motor.
5. Remove motor assembly.
6. Undo the four lockouts holding the motor to the motor support.

C. INSTALLATION OF NEW MOTOR (See Drawing on Parts Page 2):

7. Fasten the new motor to the support with four locknuts,
8. Install nylon washer between cavity and motor support.
9. Place the new motor assembly in position until the motor shaft is exactly centered in the hole where it penetrates the cooking compartment; check from the front side.
10. Reconnect wiring to the motor.
11. Place the seal on motor shaft (without grease); thin lip of seal in direction of cavity. Seal should make a good contact on cavity.

D. INSTALLATION OF FAN (See Drawing on Parts Page 2):

12. Before installing the fan check the following points:
 - a. The motor assembly must be secure.
 - b. The motor shaft must be centered in the hole.
 - c. The motor must turn freely.
 - d. The seal must be in place on the shaft inside the cooking compartment.
13. Coat the inside of the fan hub and the motor shaft with a high-temperature, waterproof anti-seize compound (LOCTITE 771 or equivalent).
14. Position fan in place. Apply suitable grade adhesive on set screw threads (LOCTITE or equivalent), position set screw in place and tighten to secure fan on shaft. Place plastic plug in front hole.
15. Rotate the fan by hand to see if everything is smooth. The fan should rotate freely, not rubbing against anything.
16. Reassemble interior components and place switch in "MANUAL" position. Within five (5) minutes steamer should be up to temperature and fan should be running. Check for proper rotation (CCW).



ADJUSTMENTS

REPLACEMENT OF DOOR GASKET (See Drawing on Parts Page 2):

1. Open door and remove inner panel assembly by sliding panel toward you and lifting out of door.
2. Place panel assembly facing down on a flat surface.
3. Remove the two (2) nuts holding two (2) retaining panels and gasket.
4. Install new gasket around inside panel.
5. Two spacers must be installed on studs inside of panel. Front panel inside of gasket.
6. Install flange deflector down, opposite to the turn-down edge panel and then install two nuts.
7. Place panel assembly in door with turn-down edge of panel nearest you. Slide panel toward you, push downward and secure turn-down edge by sliding panel toward unit.
8. Close door, turn on unit and test for leaks around the door.
9. If required, door can be adjusted by means of the four screws holding the door to the hinges.
To adjust door, loosen the four screws, position door to obtain light pressure on gasket and tighten the four screws. Make sure the two corners of the door are in line with the corners of the unit.
10. Further adjustment is possible by adding or removing shims under the door catch plate. Removing shims will increase pressure on top edge of gasket.
If these instructions are followed carefully, door should be easy to operate and without steam or water leaks.

NOTE: This unit must be free-venting through the drain. Any restriction at drain outlet or failure to install drain according to installation instructions will cause the steam to escape around door due to excessive backpressure in the unit

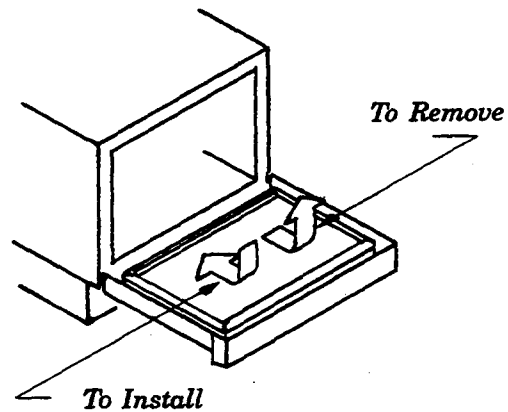

REMOVAL OF INNER PANEL ASSEMBLY (DETAIL)

DOOR HINGE TUBING ASSEMBLY (See Drawing on Parts Page 2):

TO REMOVE:

1. Open door and unscrew (4) #10-32 screws.
2. Remove door hinge each side, freeing the door hinge tubing assembly.
3. Remove torsion springs, inspect for damage; replace if defective.

TO REASSEMBLE:

1. Insert door hinge tubing assembly in between tabs on front frame.
2. Install #10-32 screws, being sure to apply thread sealer.
3. Reinstall door; check for smooth operation.

SERVICE

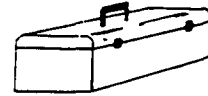

TROUBLE SHOOTING:

FIRST — CHECK THE BASICS. The unit needs power, water, and an open drain to operate properly.

BASIC #1 — POWER: Is there power to the unit of the proper voltage and phase?

BASIC #2 — LOW WATER: Is there water flowing into the compartment? Be sure all water valves are open.

BASIC #3 — DRAIN: Is the drain line open (no solid connection), short (about three feet), and without obstructions?

Check the BASICS. Then, and only then, can malfunction of controls be considered.

Refer to "INSTALLATION INSTRUCTIONS" section of this service manual to make sure the unit was installed properly. After all previous steps have been complied with, proceed with this trouble shooting guide. Carefully check *all* symptoms listed to find the one closest to the actual malfunction of your steamer.

NOTE: Improper installation may void warranty.

TROUBLE SHOOTING GUIDE: (Always Press Power Off)

Problem:	Look For:	Correction:
Steam leaks around the door.	— BASIC #3 - DRAIN The drain either wasn't installed properly or has developed an obstruction of some sort, causing a back pressure in the cooking compartment.	Check drain line installation. The drain line must be short, at a slope, not physically connected to any drain system and without restrictions. (No drain traps.)
	— Worn door gasket.	Replace gasket.
No water in the cooking compartment (or very little water). Non thermostat element type: Yellow-Low water light on or thermostat element type: Red—Trouble light on	— BASIC #2 - WATER Drain overflow not in place.	Drain overflow should be inserted in drain of cooking compartment.
	— Water valve shut off.	Check any water valves to the unit.
	— Water may be shut off elsewhere in building.	Make sure <i>cold</i> water line to unit is on.
	— Waterstrainer may be plugged.	Clean as necessary.
	— Flow control valve may be plugged.	Clean as necessary.
	— Tank solenoid may be plugged or not operating.	Check tank solenoid.
	— Inlet to cooking compartment may be plugged.	Clean as necessary.
— Low water pressure.	Water pressure must be 30 P.S.I. (207 KPA) minimum.	

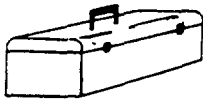

SERVICE

TROUBLE SHOOTING GUIDE: (Continued)

Problem:	Look For:	Correction:
No steam.	— BASIC #1 - POWER	Is there power to the unit? Does the supply match the rating on the nameplate?
	BASIC #2 - WATER	There must be at least 1/4" (6 mm) of water covering floor of cooking compartment. (If no water on floor of cooking compartment, SEE SYMPTOM #2).
	— No power to the contactor coil or defective contactor.	See Wiring Diagram and trace voltages through proper circuits. Check element thermostats. If Contactor is operating properly, check both sides of contactor to make certain all phases are going to the elements.
	— Defective heating elements.	Check all elements. Replace if necessary. <i>NOTE: If elements are replaced, check Section 3-Page 1 for service procedure.</i>
	Defective element thermostats.	Check thermostat — contacts should be closed at room temperature.
<hr/>		
Fan Motor doesn't run.	<i>NOTE: Generally, if you can spin the fan by hand, the motor will not be defective unless it is overheating. See cause "E" below.</i>	
	<i>NOTE: Before fan motor will turn on, door switch must be energized. (Check fuse and Master Switch also.)</i>	
	— Fuse.	Check — replace if necessary. Turn master switch to manual position.
	— Loose door latch.	Adjust so door will close and activate door switch.
	Temperature in motor compartment is too high. (Motor will stop automatically if overheating — it will reset automatically when temperature returns to normal.)	There must be at least three inches clearance at back of unit. Unit must not be located near high heat-producing pieces of equipment — see installation instructions.
Slow cooking or unit won't get hot enough to make much steam.	— BASIC #2 - WATER	Check Symptom #2.

COUNTER TOP CONVECTION STEAMER PARTS

PARTS

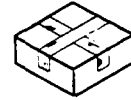

WARNING:
INSTALLATION OF OTHER THAN GENUINE SOUTHBEND PARTS WILL VOID THE WARRANTY ON THIS EQUIPMENT,

The serial plate is located on exterior right side at rear.

Replacement parts may be ordered either through a Southbend Authorized Parts Distributor or a Southbend Authorized Service Agency.

When ordering parts please supply the Model Number, Serial Number, Part Number, Description, plus Finish, and Electrical Characteristics, as applicable.

For parts not listed consult a Southbend Authorized Parts Distributor or Southbend Authorized Service Agency. If necessary, please consult Southbend Parts Department for assistance.

NOTE: NO THERMOSTAT ELEMENT CONTROLS ON UNITS Serial Number 91G and before. Units Serial Number 91H and up have thermostat element controls and a red trouble light replaces the amber low water light.

CONTROL PANEL VIEW

KEY NO.	PART NO.	DESCRIPTION
1	1167592	POLYPANEL, Serial 91G and before
	1173537	POLYPANEL, Serial 91H and after
2	A93-00023	POWER SWITCH (PE-172)
3	6600030	LOW WATER LIGHT, 240V, AMBER, Serial 91G and before
	6600028	TROUBLE LIGHT, 240V, Red, Serial 91H and after
4	PE.195	TIMER
	PE-196	KNOB FOR TIMER
5	A9340025	AUTO/MANUAL SWITCH (A93-00029)
6	1109900	BUZZER,240V
	Not Shown	CONTROL PANEL, Serial 91G and before
	132282	CONTROL PANEL, Serial 91H and after

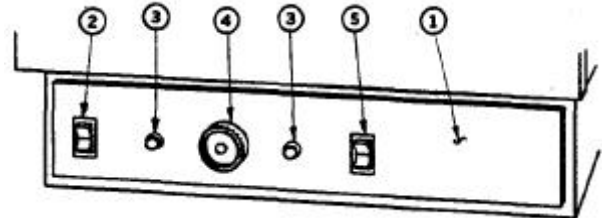

2001 SINGLE POWER CONNECTION

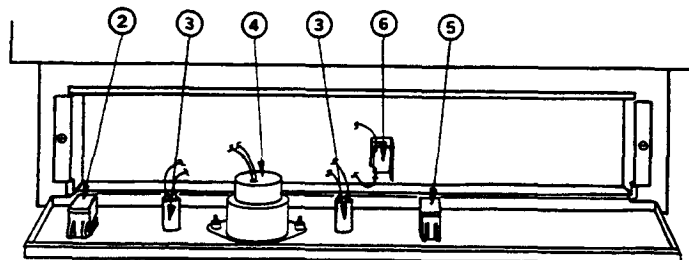

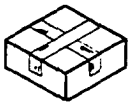

PARTS

2001 SINGLE POWER CONNECTION

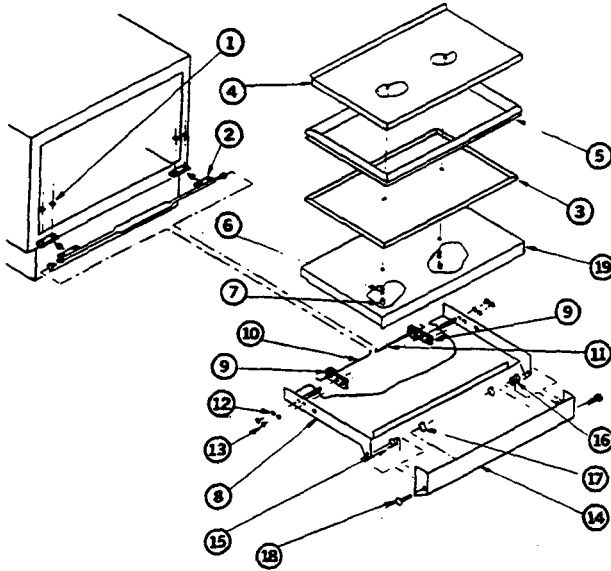

DOOR ASSEMBLY MOUNTING VIEW

KEY NO.	PART NO.	DESCRIPTION
1	1167325	SCREW, HINGE MOUNT (PH-158)
2	1168259	DOOR PIVOT SHAFT TUBE (132-223)
3	A11.00019	BASKET FRAME (132-305)
4	A11-00018	INSIDE PANEL (132-306)
5	A16-00004	DOOR GASKET (132-255)
6	6600367	SPACER (PH-404)
7	6600430	LOCK NUT (PH-406)
8	1167344	DOOR PANEL (Exterior) (132-188)
9	132321	DOOR HINGE BLOCK (Left or Right)
10	6600416	HINGE SPRING (Left) (132-046-1)
11	6600414	HINGE SPRING (Right) (132-046-2)
12	6600412	LOCKWASHER, SS. ¼ (PH-256)
13	6600410	SCREW, HINGE BLOCK (PH-007)
14	1173531	DOOR HANDLE (132-121) (6600376)
	1173530	DOOR LATCH
15	6600396	SPRING, HANDLE (Left Hand) (132-018-1)
16	6600398	SPRING, HANDLE (Right Hand) (132-018-2)
17	6600402	SPRING CLIP (PH-307)
18	6600400	PIVOT PIN, HANDLE (132-027-1)
19	11-00029	HOLDING PLATE (132-307)

Kit [A03-00030](#) includes items 3, 4, 5, 6 & 7 (132-304)

Kit [A03-00054](#) includes items 8 thru 19 (132-303)

Kit [4440334](#) Door Latch/catch Improvement Kit includes 1 each:
1173531, 1173530, 1173529

Kit [6600370](#) includes items 3 thru 19

MOTOR AND FAN MOUNTING

KEY NO.	PART NO.	DESCRIPTION
1	132-320	MOTOR, 208-240V
2	1167330	BRACKET, MOTOR (132-013)
3	6600430	LOCK NUT (132-200)
4	1168255	BLOWER WHEEL (132-233, 1167331)
5	A16-00005	SHAFT SEAL - CAVITY (PM-122)
6	A60-00003	WASHER, NYLON (130-135)
7	1167332	SET SCREW (PH-172)
8	A59-00020	HOLE PLUG BUTTON (PM-005)

2001 SINGLE POWER CONNECTION

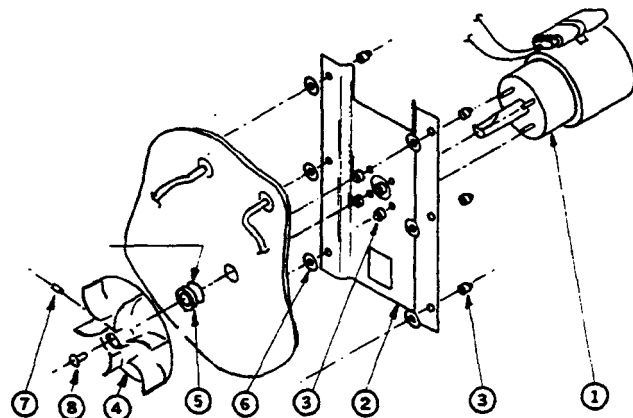

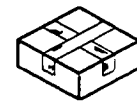

BACK VIEW OF STEAMER

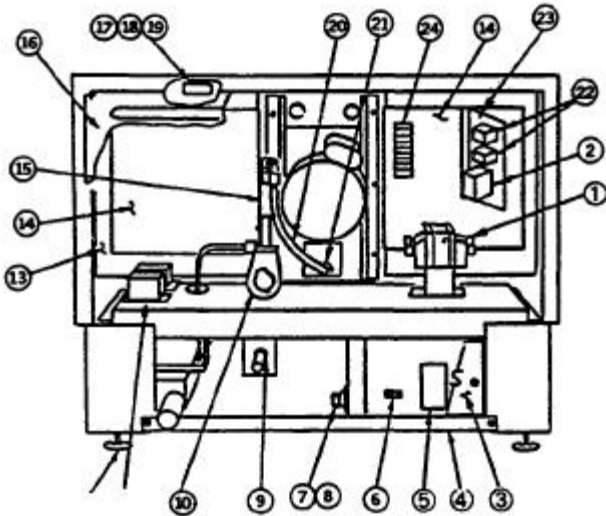

KEY NO.	PART NO.	DESCRIPTION
1	1173448	CONTACTOR (6600052 - 2001 only)
2	PE-194	RELAY, ELEMENT, 240V (REPLACES PE-181)
3	1167340	COVER. TERMINAL BLOCK (132-195)
4	6600462	BOTTOM COVER PANEL, 2001 (132-024)
5	PE-023	TERMINAL BLOCK SECTION, (4) Req'd.
6	1160031	GROUND LUG
7	1012596	FUSE HOLDER
8	1012510	FUSE, 15 AMP (PE-018.1167336)
9	1173428	IN-LINE STRAINER (REPLACES #PP-629) ²
9	4440329	REPLACEMENT STRAINER KIT
9a	1173429	REPLACEMENT SCREEN ONLY FOR 1173428
10	1173293	SEE BELOW
11	A93-00022	HI-LIMIT (PE-171)
12	1167328	FOOT, ADJUSTABLE (OPTIONAL) (PM-018)
13	A19-00014	INSULATION, REAR (132-100-3)
14	A14-00027	INSULATION COVER (132-293)
15	PP.636	SEE BELOW
16	6600466	REAR COVER PANEL
17	A39-00021	BRACKET, DOOR INT. SWITCH (132-245)
18	1172988	DOOR PUSH ROD, 2001
19	1142000	INTERLOCK SWITCH (PE-129)
20	A24-00002	HOSE, CAVITY RLL (132-278)
21	PM-019	CLAMP.HOSE
22	PE-179	RELAY. SMALL
23	1170008	BRACKET. RELAYS (132-314) Serial 91G and before
23	1174309	RELAY MOUNTING BRACKET. Serial 91H and after
24	1170335	TERMINAL STRIP. Serial 91H and after

2001 SINGLE POWER CONNECTION

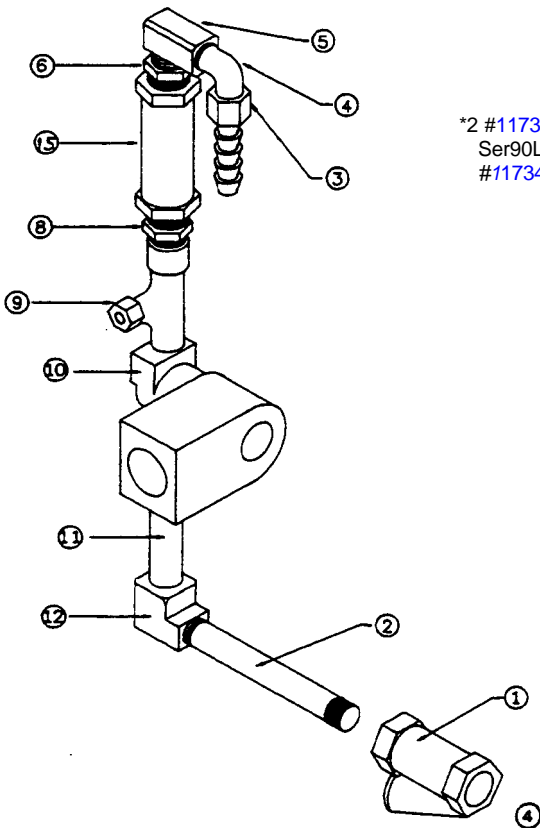

*2 #1173428 Replaces #PP-629 starting Jan 91. Ser91A and up. For older units: Ser90L and before use #4440329 Kit for first time replacement only and then #1173428 or #1173429.

WATER INLET ASSEMBLY

ITEM	PART NO.	DESCRIPTION
1	1173428	STRAINER
1a	1173429	REPLACEMENT SCREEN ONLY FOR 1173428
2	1173432	FOUR INCH NIPPLE
3	PP-634	FITTING FEMALE SWIVEL 1/4" HOSE
4	PP-224	90° ELBOW
5	PP-232	ELBOW 1/4 MALE FEMALE
6	PP-204	REDUCER 3/8 MALE 'A FEMALE
15	PP-636	FLOW REGULATOR
8	PP-223	REDUCER 3/8 NPT MALE, 1/4 NPT MALE
9	PP-710	BRASS TEE
10	1173293	SOLENOID 208-240V
11	PP-206	THREE INCH MALE NIPPLE
12	PP-213	90° ELBOW

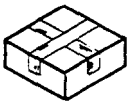

PARTS

INSIDE VIEW OF STEAMER

KEY NO.	PART NO.	DESCRIPTION
1	A95-00002	ELEMENT, CAVITY, 2001
2	1167320	FAN GUARD, 2001 (132-206)
3	1167323	SIDE RACKS, 2001 (132-180)
4	1173529	DOOR CATCH (132-042) (6600434)
	6600509	DOOR CATCH SHIM (132-105-1)
5	1172964	DOOR CATCH SCREW*
	1167321	DOOR CATCH SCREW (PH-004)* ¹
6	6600044	PUSH BUTTON (132-079-2)
7	1168255	BLOWER WHEEL. 2001 (132-205)
8	1167332	SET SCREW. BLOWER WHEEL (PH-172)
9	A1640004	GASKET, DOOR. 2001 (132-255)
10	A11-00018	INSIDE PANEL. DOOR. 2001 (132-304)
11	13206-3	DRAIN TUBE/PLUG W/CHAIN / (1173168,1167322)
12	6600244	WATER FILL JET (132-028-1)
13	6600248	GASKET. WATER JET (132-138)
14	1146403	NUT, WATER FILL JET
15	A81-00004	SLIDE KIT
16	1167263	ARM DOOR SLIDE (132-195)
17	A81-00049	PIVOT KIT (132-309,132-312)
18	6600454	DRAIN PAN (132-033)

2001 SINGLE POWER CONNECTION

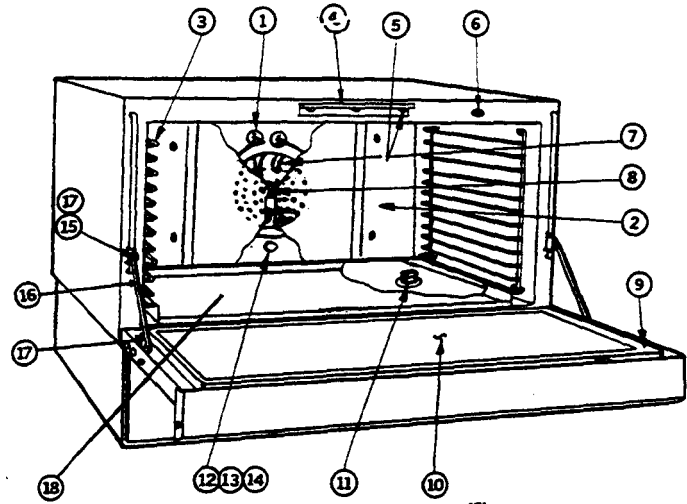

*¹ #1172964 for units produced Jan. 91 and after. Ser91A and up.
 #1167321 for units produced Dec. 90 and before. Ser90L and before.

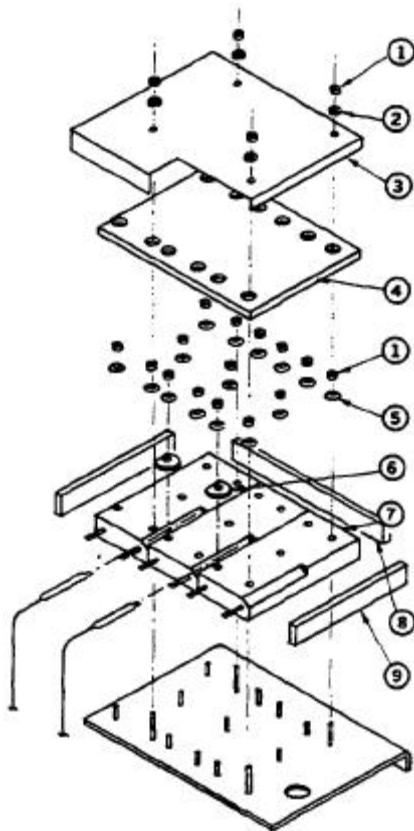

MOUNTING VIEW - ELEMENTS FOR UNITS WITHOUT THERMOSTATS ON ELEMENTS SERIAL NUMBER 91 G & BEFORE

KEY NO.	PART NO.	DESCRIPTION
1	1146413	NUT, ¼ -20 (PH-202)
2	1146500	LOCKWASHER, 1/4 (PH-251)
3	A14-00026	COVER, ELEMENT INSULATION (132-295)
4	A19-00011	ELEMENT INSULATION, MAIN (132-294-1)
5	PH-422	SPRING WASHER
6	A60-00005	WASHER, LIMIT THERMOSTAT (132-296)
7	1174304	ELEMENT 208V (132-264-1/1168029)
	1174305	ELEMENT 240V (132-264-2/1168028)
8	A19-00012	ELEMENT INSULATING BLOCK - FRONT/REAR (132-294-3)
9	A19-00013	ELEMENT INSULATING - SIDES THERMO JOINT COMPOUND (132-294-2)
	PN-126	THERMAL GREASE



2001 THERMOSTATIC
UNDERSIDE COMPONENTS/WIRING ROUTING

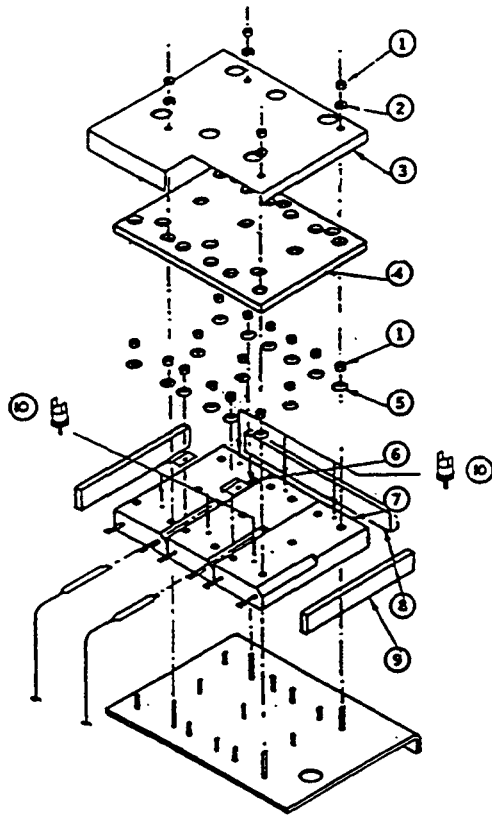

MOUNTING VIEW - ELEMENTS
FOR UNITS WITH THERMOSTATS ON ELEMENTS
SERIAL NUMBER 91 H & AFTER

KEY NO.	PART NO.	DESCRIPTION
1	1146413	NUT, ¼ -20 (PH-202)
2	1146500	LOCKWASHER. ¼ (PH-251)
3	1174307	COVER. ELEMENT INSULATION
4	1174306	ELEMENT INSULATION, MAIN
5	PH-422	SPRING WASHER
6	1174308	RETAINER. HI-LIMIT BULB
7	1174304	ELEMENT 208V
	1174305	ELEMENT 240V
8	A19-00012	ELEMENT INSULATING BLOCK - FRONT/REAR (132-294-3)
9	A19.00013	ELEMENT INSULATING - SIDES THERMO JOINT COMPOUND (132-294-2)
	PN-126	THERMAL GREASE
10	1174302	THERMOSTAT. ELEMENT. (6)
11	1174300	WIRE ROUTING CHANNEL
12	1161675	BUSHING (9)
13	1174299	WIRE ROUTING SUPPORT
14	1174301	WIRING SHIELD

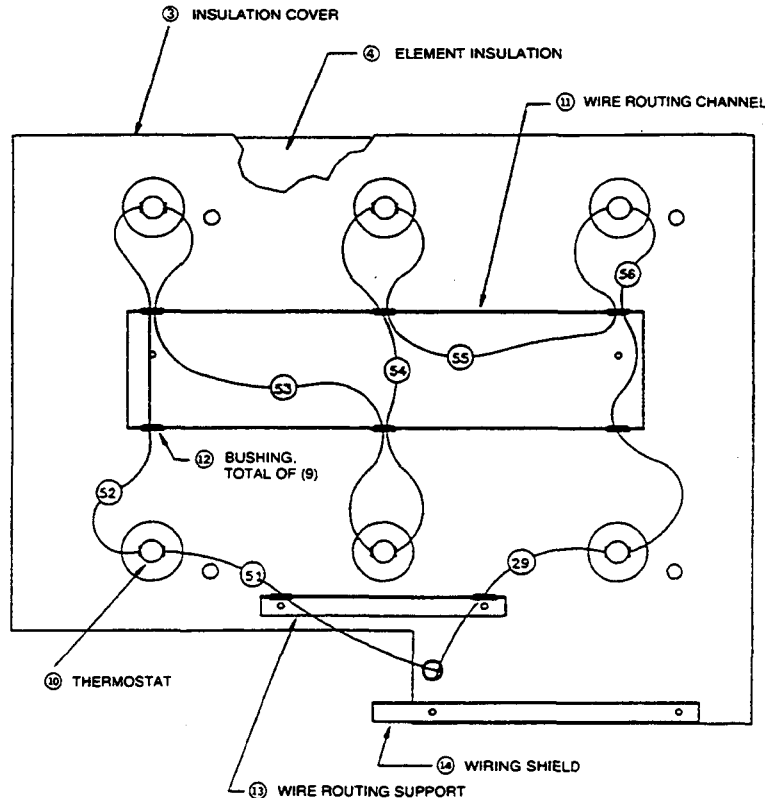

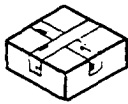

PARTS

CONDENSOR

KEY NO.	PART NO.	DESCRIPTION
1	A12-00027	CONDENSOR. CONDENSOR BOX ONLY
2	6600329	INLET FLANGE. CONDENSOR
3	6600241	SPRAY NOZZLE. CONDENSOR (PP-632)
4	P4119	FITTING
5	6600334	SCREW
6	6600316	TEFLON WASHER (130-169)

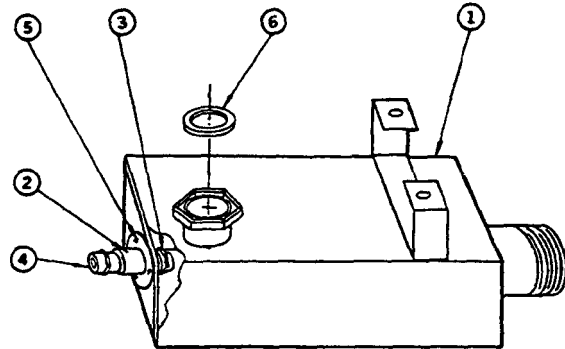

MISCELLANEOUS PARTS NOT SHOWN IN PHOTOS OR DRAWINGS

KEY NO.	PART NO.	DESCRIPTION
	1167328	ADJ. FOOT ONLY (PM-018)
	1172857	STEEL LEG ASS'Y. SET OF 4. (optional) (6600362)
	1163561	STEEL LEG ASS'Y. (1 only) (PM-015) (6600361)
	1173012	OWNERS MANUAL
	1173354	LAMINATED CLEANING INSTRUCTIONS